



PHF3

Product Specifications

13 SEER PACKAGE HEAT PUMP UNIT (Single Phase) 2 - 4 TONS

REFRIGERATION CIRCUIT

- All models are equipped with high efficiency Copeland scroll compressor, 4 ton has two-stage scroll compressor.
- Thermostat Expansion Valve (TXV) controls refrigerant flow.
- High Efficiency indoor motors on all models.
- Factory charged with R-22 refrigerant.



BUILT TO LAST

- Galvanized-painted cabinet. One piece weather resistant top. Access panels for easy service. Side by side supply and return. Heavy gauge base rails.
- Triple-coated steel, consisting of a polyester top coat, a urethane primer coat preceded by an oxide pretreatment.
- Integral base rails with fork-lift access. Holes provided for lifting lugs makes rooftop installation easier.
- The condenser coil has a sturdy wire inlet grille and UV rated vinyl mesh installed on the surface of the coil for additional protection.
- Electronic Defrost Control
- Drawn fan orifice and swept fan blades on most models for quieter operation.



EASY TO INSTALL AND SERVICE

- Combination electric cooling and heat, self contained for year-round comfort. Systems installed on rooftop or ground level. The unit is shipped in the horizontal position and can easily be converted to downflow.
- Externally-mounted gauge ports allow for more accurate reading of operating conditions while servicing.
- Electrical controls located behind one exterior panel for easier maintenance.

ELECTRIC HEAT

- 5 to 20 kW.

WARRANTY

- 5-year parts limited warranty (including compressor and coils)

UNIT PERFORMANCE DATA (208/230V - 1 Phase - 60 Hz)

Model Number	COOLING		HEATING			Unit Dimensions H x W x L	Ship Weight
	Rated Capacity BTUH	S.E.E.R	High Heat Capacity BTUH @ 47° F	HSPF	Low Heat Capacity BTUH @ 17° F		
PHF324000K00A	23,000	13.2	22,000	7.7	12,200	29-1/2 X 47-1/2 X 47-1/2	277
PHF330000K00A	28,600	13.2	28,000	7.7	15,400	37-1/2 X 47-1/2 X 47-1/2	313
PHF336000K00A	35,000	13.2	34,000	7.7	18,600	37-1/2 X 47-1/2 X 47-1/2	320
PHF342000K00A	40,000	13.2	39,000	7.7	21,600	37-1/2 X 47-1/2 X 47-1/2	342
PHF348000K00A	44,500	13.2	44,500	7.7	24,200	37-1/2 X 47-1/2 X 47-1/2	394

UNIT SPECIFICATIONS

MODEL NUMBER	Electrical Data			Condenser Data									Sound Ratings (db)
	208 / 230 Voltage Ph. - Hz.	HACR Brkr/ Max. Fuse	Minimum Circuit Ampacity	Coil			Fan Motor			Fan			
				Total Face Area (Sq. Ft.)	Fins Per In. / Rows	Tube Dia. (In.)	Horse power	Full Load Amps	Locked Rotor Amps	Size Diameter (In.)	RPM Max.	CFM (Max.)	
PHF324000K00A	1-60	25 amps.	18.6	11.19	18 / 2	3/8	1/8	0.9	1.6	20	825	2100	72
PHF330000K00A	1-60	30 amps.	21.8	13.50	18 / 2	3/8	1/8	0.9	1.6	20	825	2100	74
PHF336000K00A	1-60	45 amps.	31.8	14.60	18 / 2	3/8	1/4	1.4	3.7	20	1100	2700	76
PHF342000K00A	1-60	45 amps.	29.7	14.60	18 / 2	3/8	1/4	1.4	3.7	20	1100	2700	78
PHF348000K00A	1-60	60 amps.	39.9	13.50	18 / 2	3/8	1/4	1.4	3.7	20	1100	3000	78

MODEL NUMBER	Evaporator Coil										Refrigerant Charge R-22 (lbs)	Shipping Weight (Lbs/kg)	
	Coil			Motor			Blower			Compressor			
	Total Face Area (Sq. Ft.)	Fins Per In. / Rows	Tube Diameter (In.)	H.P.	Full Load Amps	No. of Speed Taps	Size	RPM (Max.)	CFM Rated	Rated Load Amps			Locked Rotor Amps
PHF324000K00A	4	14 / 3	3/8	1/2	4.1	4	10 x 8	1050	800	10.9	54.0	8.0	293
PHF330000K00A	5.33	14 / 3	3/8	1/2	4.1	4	10 x 8	1050	1000	13.5	72.5	10.0	313
PHF336000K00A	5.33	14 / 3	3/8	3/4	6.0	4	11 x 9	1050	1200	19.6	88.0	11.2	320
PHF342000K00A	5.33	14 / 4	3/8	3/4	6.0	4	11 x 9	1050	1400	17.8	95.0	12.0	347
PHF348000K00A	5.33	14 / 4	3/8	1.0	7.7	4	11 x 10	1050	1600	24.7	116.0	13.2	392

PERFORMANCE DATA: COOLING

MODEL NUMBER	Cooling Data			Heating Data						Power Input Watts	Evaporator Rated Airflow (SCFM)	Ext. Static Pressure Drop ³ Wet
	Rated Capacity ² BTUH Cooling	S.E.E.R.	E.E.R.	Rated Capacity ¹ BTUH @ 47° f	Rated Capacity ¹ BTUH @ 17° f	HSPF	S / T Ratio	COP				
								@ 47° f	17° f			
PHF324000K00A	23,000	13.2	11.3	22,000	12,200	7.7	.76	3.5	2.2	2090	800	0.18
PHF330000K00A	28,600	13.2	11.3	28,000	15,400	7.7	.76	3.6	2.3	2600	1000	0.23
PHF336000K00A	35,000	13.2	11.0	34,000	18,600	7.7	.78	3.4	2.3	3182	1200	0.23
PHF342000K00A	40,000	13.2	11.0	39,000	21,600	7.7	.76	3.4	2.3	3636	1400	0.28
PHF348000K00A	44,500	13.2	10.2	44,000	24,200	7.7	.76	3.5	2.3	4363	1600	0.28

¹ Rated Capacity @ 47° F.

² Rated Capacity @ 230 Volts. For applications at 208 volts deduct 1000 BTU. Contact distributor for availability dates.

³ Includes a .08 drop for a filter.

BLOWER PERFORMANCE DATA

Model Number	PHF324000K00A				PHF330000K00A				PHF336000K00A				PHF342000K00A				PHF348000K00A				
Speed Tap	1	2	3	4	1	2	3	4	1	2	3	4	1	2	3	4	1	2	3	4	
Air Delivery in CFM @ Varying External Static Pressure (in. w.c.)	0.1	891	-	1136	-	986	1076	1286	1352	1162	1278	1529	1652	1138	1240	1505	1643	1154	1245	1750	1908
	0.2	845	-	1098	-	949	1038	1225	1311	1118	1233	1484	1607	1087	1189	1467	1609	1084	1170	1696	1864
	0.3	804	-	1056	-	908	997	1186	1274	1062	1191	1440	1574	1041	1145	1431	1577	1005	1110	1643	1819
	0.4	758	-	1020	-	856	973	1158	1233	1014	1149	1402	1541	989	1104	1398	1541	940	1034	1592	1770
	0.5	707	-	980	-	819	913	1129	1203	958	1108	1364	1501	940	1063	1363	1509	880	972	1547	1720
	0.6	649	-	920	-	781	875	1085	1162	892	1060	1326	1462	865	1010	1324	1476	832	924	1497	1678
	0.7	582	-	785	-	717	840	1044	1119	826	1005	1284	1426	806	952	1283	1439	780	875	1443	1632
	0.8	509	-	569	-	664	786	1004	1066	780	943	1238	1384	752	891	1234	1402	713	836	1400	1586
	0.9	-	-	318	-	612	717	948	989	735	892	1179	1338	694	828	1175	1352	663	773	1354	1538
	1	-	-	-	-	554	659	755	774	675	844	1123	1277	646	773	1120	1264	613	720	1302	1494

Notes: Air Delivery @ listed external static pressure are taken at 230Volts with Dry coil, no filter and approved heater.

For wet coil add .05 in. wc. to Static Pressure measurement. Note for 208 Volts applications, reduce airflow by 15%.

COOLING EXPANDED PERFORMANCE

PHF324000K00A

		700					800					900				
OD Ambient (°F)	ID Airflow (SCFM)	Entering Indoor Temperature - Degrees F, Wet Bulb														
		57	62	63††	67	72	57	62	63††	67	72	57	62	63††	67	72
75	MBh†	22.1	23.0	23.5	25.2	26.5	23.3	23.8	24.1	25.5	26.6	24.3	24.3	24.4	25.8	27.4
	S/T	1.00	0.91	0.73	0.70	0.52	1.00	0.96	0.76	0.73	0.53	1.00	0.99	0.80	0.77	0.53
	kW*	1.7	1.7	1.7	1.7	1.7	1.8	1.8	1.8	1.8	1.8	1.8	1.8	1.8	1.9	1.9
85	MBh†	21.3	22.0	22.5	24.5	26.3	22.5	22.7	23.1	25.1	26.4	23.5	23.5	23.7	25.5	27.1
	S/T	1.00	0.93	0.74	0.71	0.52	1.00	0.98	0.77	0.74	0.55	1.00	0.99	0.81	0.78	0.56
	kW*	1.9	1.9	1.9	1.9	1.9	2.0	2.0	2.0	2.0	2.0	2.0	2.0	2.0	2.0	2.1
95	MBh†	20.5	20.9	21.4	22.9	26.0	21.6	21.6	22.0	23.0	26.1	22.6	22.6	22.5	24.5	26.8
	S/T	1.01	0.96	0.75	0.72	0.52	1.00	0.99	0.79	0.76	0.55	1.00	1.00	0.83	0.80	0.56
	kW*	2.1	2.1	2.1	2.1	2.1	2.2	2.2	2.2	2.2	2.2	2.2	2.2	2.2	2.3	2.3
105	MBh†	19.6	19.8	20.2	22.1	24.9	20.7	20.7	20.8	22.7	25.5	21.6	21.6	21.2	23.2	26.0
	S/T	1.00	0.99	0.77	0.74	0.53	1.00	0.99	0.81	0.78	0.55	1.00	1.00	0.85	0.82	0.57
	kW*	2.3	2.3	2.3	2.3	2.4	2.4	2.4	2.4	2.4	2.4	2.5	2.5	2.5	2.5	2.5
115	MBh†	18.6	18.7	19.0	20.9	23.6	19.6	19.7	19.5	21.4	24.2	20.5	20.5	19.9	21.9	24.6
	S/T	1.00	1.00	0.79	0.76	0.54	1.00	0.99	0.84	0.80	0.56	1.00	0.99	0.88	0.85	0.58
	kW*	2.5	2.5	2.5	2.6	2.6	2.6	2.6	2.6	2.6	2.7	2.7	2.7	2.7	2.7	2.8
125	MBh†	17.5	17.6	17.6	19.4	22.1	18.5	18.6	18.0	20.0	22.7	19.4	19.4	18.4	20.4	23.1
	S/T	1.00	0.99	0.82	0.79	0.55	1.00	1.00	0.87	0.83	0.57	1.00	1.00	0.91	0.88	0.60
	kW*	2.8	2.8	2.8	2.8	2.9	2.9	2.9	2.9	2.9	2.9	3.0	3.0	3.0	3.0	3.0

PHF330000K00A

		875					1000					1125				
OD Ambient (°F)	ID Airflow (SCFM)	Entering Indoor Temperature - Degrees F, Wet Bulb														
		57	62	63††	67	72	57	62	63††	67	72	57	62	63††	67	72
75	MBh†	27.0	28.2	28.9	30.7	32.0	28.7	29.1	29.5	31.1	32.9	29.9	29.9	29.9	31.3	33.1
	S/T	0.99	0.91	0.72	0.70	0.50	0.99	0.96	0.75	0.74	0.49	0.99	0.99	0.79	0.78	0.49
	kW*	2.1	2.1	2.1	2.1	2.1	2.2	2.2	2.2	2.2	2.2	2.3	2.3	2.3	2.3	2.3
85	MBh†	25.7	26.4	27.1	30.0	32.4	27.3	27.4	28.0	30.7	32.7	28.7	28.8	28.8	31.2	32.9
	S/T	0.99	0.94	0.74	0.70	0.52	0.99	0.99	0.77	0.74	0.54	0.99	0.99	0.81	0.78	0.56
	kW*	2.3	2.3	2.3	2.3	2.3	2.4	2.4	2.4	2.4	2.4	2.5	2.5	2.5	2.5	2.5
95	MBh†	24.5	24.8	25.4	28.1	31.7	25.9	26.0	26.2	28.6	32.3	27.2	27.3	26.9	29.7	32.6
	S/T	0.99	0.97	0.76	0.72	0.52	0.99	0.99	0.79	0.76	0.54	0.99	0.99	0.83	0.80	0.56
	kW*	2.5	2.5	2.5	2.6	2.6	2.6	2.6	2.6	2.6	2.6	2.7	2.7	2.7	2.7	2.7
105	MBh†	23.2	23.3	23.7	26.3	30.0	24.6	24.7	24.5	27.1	30.9	25.8	25.8	25.0	27.7	31.6
	S/T	0.99	0.99	0.78	0.75	0.53	0.99	0.99	0.82	0.79	0.55	0.99	0.99	0.86	0.83	0.57
	kW*	2.8	2.8	2.8	2.8	2.8	2.8	2.8	2.8	2.9	2.9	2.9	2.9	2.9	3.0	3.0
115	MBh†	21.8	21.9	21.9	24.4	28.0	23.2	23.3	22.6	25.1	28.9	24.3	24.4	23.1	25.7	29.5
	S/T	0.99	0.99	0.81	0.77	0.54	0.99	0.99	0.85	0.82	0.56	0.99	0.99	0.90	0.86	0.59
	kW*	3.0	3.0	3.0	3.1	3.1	3.1	3.1	3.1	3.1	3.2	3.2	3.2	3.2	3.2	3.3
125	MBh†	20.3	20.4	19.8	22.5	26.0	21.6	21.7	20.4	23.2	26.7	22.8	22.8	20.9	23.7	27.3
	S/T	0.99	0.99	0.85	0.80	0.55	0.99	0.99	0.90	0.85	0.58	0.99	0.99	0.95	0.90	0.61
	kW*	3.3	3.3	3.3	3.3	3.4	3.4	3.4	3.4	3.4	3.5	3.5	3.5	3.5	3.5	3.6

Notes: When the required data fall between the published data, interpolation may be performed. Extrapolation is not an acceptable practice.

† Total capacities are net capacities. Blower heat has been subtracted

†† At TVA rating indoor condition (75 F db/ 63 F wb), All other indoor air temperatures are at 80 F db

* System kW is total unit kW

Key: Standard Rating

S/T are based on 80°F db entering air at the indoor coil. For sensible capacities at other than 80°F db, deduct 835 Btuh per 1000 cfm of indoor coil air from MBhxS/T for each degree below 80°F, or add 835 Btuh per 1000 cfm of indoor coil air from MBhxS/T for each degree above 80°F.

COOLING EXPANDED PERFORMANCE

PHF336000K00A

OD Ambient (°F)	ID Airflow (SCFM)	1050					1200					1350				
		Entering Indoor Temperature - Degrees F, Wet Bulb														
		57	62	63††	67	72	57	62	63††	67	72	57	62	63††	67	72
75	MBh†	32.9	34.1	34.8	37.6	40.5	36.3	36.3	36.7	38.9	41.2	37.4	37.4	37.4	39.2	41.3
	S/T	0.97	0.89	0.84	0.68	0.50	0.97	0.97	0.94	0.75	0.53	0.97	0.97	0.97	0.78	0.55
	kW*	2.4	2.4	2.4	2.4	2.4	2.5	2.5	2.5	2.5	2.6	2.5	2.5	2.6	2.6	2.6
85	MBh†	31.8	32.7	33.3	36.1	39.8	35.0	35.0	35.1	37.7	40.9	36.1	36.2	36.2	38.1	41.1
	S/T	0.97	0.90	0.86	0.69	0.51	0.97	0.97	0.96	0.77	0.54	0.97	0.97	0.97	0.80	0.56
	kW*	2.6	2.6	2.7	2.7	2.7	2.8	2.8	2.8	2.8	2.8	2.8	2.8	2.8	2.9	2.9
95	MBh†	30.7	31.2	31.8	34.5	38.4	33.6	33.6	33.6	35.0	39.7	34.7	34.7	34.7	36.4	40.0
	S/T	0.97	0.93	0.88	0.70	0.51	0.97	0.97	0.97	0.78	0.55	0.97	0.97	0.97	0.82	0.57
	kW*	2.9	2.9	2.9	3.0	3.0	3.0	3.0	3.0	3.1	3.1	3.1	3.1	3.1	3.2	3.2
105	MBh†	29.4	29.7	30.2	32.8	36.7	32.2	32.3	32.3	34.2	38.0	33.2	33.3	33.3	34.6	38.3
	S/T	0.97	0.95	0.90	0.72	0.52	0.97	0.97	0.97	0.81	0.56	0.97	0.97	0.97	0.85	0.59
	kW*	3.2	3.2	3.2	3.3	3.3	3.3	3.4	3.4	3.4	3.5	3.4	3.4	3.4	3.5	3.5
115	MBh†	28.1	28.1	28.5	31.0	34.8	30.7	30.7	30.8	32.2	36.1	31.7	31.7	31.7	32.6	36.4
	S/T	0.97	0.97	0.93	0.74	0.53	0.97	0.97	0.97	0.83	0.58	0.97	0.97	0.97	0.87	0.60
	kW*	3.5	3.5	3.6	3.6	3.7	3.7	3.7	3.7	3.8	3.8	3.8	3.8	3.8	3.8	3.9
125	MBh†	26.6	26.6	26.7	29.1	32.7	29.1	29.1	29.1	30.2	33.9	30.0	30.0	30.0	30.5	34.2
	S/T	0.97	0.97	0.96	0.76	0.54	0.97	0.97	0.97	0.86	0.59	0.97	0.97	0.97	0.91	0.62
	kW*	3.9	3.9	3.9	4.0	4.0	4.0	4.0	4.0	4.1	4.2	4.1	4.1	4.1	4.2	4.3

PHF342000K00A

OD Ambient (°F)	ID Airflow (SCFM)	1225					1400					1575				
		Entering Indoor Temperature - Degrees F, Wet Bulb														
		57	62	63††	67	72	57	62	63††	67	72	57	62	63††	67	72
75	MBh†	38.0	38.8	39.4	42.6	47.0	39.7	39.8	40.3	43.3	47.8	41.0	41.1	41.1	43.9	48.4
	S/T	0.96	0.91	0.86	0.69	0.51	0.96	0.96	0.91	0.73	0.52	0.96	0.96	0.96	0.76	0.54
	kW*	2.8	2.8	2.8	2.9	2.9	2.8	2.9	2.9	2.9	3.0	2.9	2.9	3.0	3.0	3.1
85	MBh†	36.9	37.3	38.0	41.0	45.3	38.4	38.5	38.8	41.7	46.0	39.7	39.8	39.8	42.2	46.5
	S/T	0.96	0.93	0.88	0.71	0.51	0.96	0.96	0.93	0.74	0.53	0.96	0.96	0.96	0.78	0.55
	kW*	3.1	3.1	3.1	3.2	3.2	3.2	3.2	3.2	3.3	3.3	3.2	3.2	3.3	3.4	3.4
95	MBh†	35.7	35.9	36.5	39.3	43.5	37.1	37.2	37.3	40.0	44.2	38.3	38.4	38.4	40.4	44.6
	S/T	0.96	0.95	0.90	0.72	0.52	0.96	0.96	0.95	0.76	0.54	0.96	0.96	0.96	0.80	0.56
	kW*	3.4	3.5	3.5	3.5	3.6	3.5	3.5	3.5	3.6	3.7	3.6	3.6	3.6	3.7	3.8
105	MBh†	34.4	34.4	34.9	37.6	41.7	35.8	35.8	35.9	38.2	42.3	36.9	37.0	37.0	38.6	42.6
	S/T	0.96	0.96	0.92	0.73	0.53	0.96	0.96	0.96	0.77	0.55	0.96	0.96	0.96	0.82	0.57
	kW*	3.8	3.8	3.9	3.9	4.0	3.9	3.9	3.9	4.0	4.1	4.0	4.0	4.0	4.1	4.2
115	MBh†	33.1	33.1	33.3	35.9	39.7	34.4	34.4	34.4	36.4	40.3	35.4	35.5	35.5	36.7	40.6
	S/T	0.96	0.96	0.94	0.75	0.53	0.96	0.96	0.96	0.79	0.56	0.96	0.96	0.96	0.84	0.58
	kW*	4.2	4.3	4.3	4.3	4.4	4.3	4.3	4.3	4.4	4.5	4.4	4.4	4.4	4.5	4.6
125	MBh†	31.7	31.7	31.7	34.0	37.7	32.9	32.9	32.9	34.5	38.2	33.9	33.9	33.9	34.8	38.4
	S/T	0.96	0.96	0.96	0.77	0.54	0.96	0.96	0.96	0.82	0.57	0.96	0.96	0.96	0.86	0.59
	kW*	4.7	4.7	4.7	4.8	4.9	4.8	4.8	4.8	4.8	4.9	4.9	4.9	4.9	5.0	5.1

Notes: When the required data fall between the published data, interpolation may be performed. Extrapolation is not an acceptable practice.

† Total capacities are net capacities. Blower heat has been subtracted

†† At TVA rating indoor condition (75 F db/ 63 F wb), All other indoor air temperatures are at 80 F db

* System kW is total unit kW

Key: Standard Rating

S/T are based on 80°F db entering air at the indoor coil. For sensible capacities at other than 80°F db, deduct 835 Btuh per 1000 cfm of indoor coil air from MBhxS/T for each degree below 80°F, or add 835 Btuh per 1000 cfm of indoor coil air from MBhxS/T for each degree above 80°F.

COOLING EXPANDED PERFORMANCE

PHF348000K00A (High Capacity)

OD Ambient (°F)	ID Airflow (SCFM)	1400					1600					1800				
		Entering Indoor Temperature - Degrees F, Wet Bulb														
		57	62	63††	67	72	57	62	63††	67	72	57	62	63††	67	72
75	MBh†	42.4	43.6	44.3	47.7	52.3	44.4	44.8	45.3	48.7	53.4	46.0	46.0	46.1	49.5	54.3
	S/T	0.98	0.91	0.72	0.70	0.51	0.98	0.95	0.76	0.73	0.53	0.98	0.98	0.79	0.77	0.55
	kW*	3.6	3.6	3.6	3.6	3.6	3.7	3.7	3.7	3.7	3.7	3.8	3.8	3.8	3.8	3.8
85	MBh†	41.2	42.0	42.6	45.9	50.5	43.0	43.2	43.6	46.9	51.5	44.5	44.6	44.4	47.7	52.3
	S/T	0.98	0.92	0.73	0.71	0.52	0.98	0.97	0.77	0.75	0.54	0.98	0.98	0.80	0.78	0.56
	kW*	3.9	3.9	3.9	4.0	4.0	4.0	4.0	4.0	4.0	4.1	4.1	4.1	4.1	4.1	4.2
95	MBh†	39.8	40.4	40.9	44.1	48.5	41.6	41.6	41.8	44.5	49.4	43.0	43.1	42.5	45.7	50.2
	S/T	0.98	0.94	0.75	0.72	0.52	0.98	0.98	0.78	0.76	0.54	0.98	0.98	0.82	0.80	0.57
	kW*	4.3	4.3	4.3	4.3	4.4	4.4	4.4	4.4	4.4	4.4	4.5	4.5	4.5	4.5	4.5
105	MBh†	38.4	38.7	39.1	42.2	46.4	40.1	40.1	40.0	43.0	47.3	41.4	41.5	40.6	43.7	48.0
	S/T	0.98	0.96	0.76	0.74	0.53	0.98	0.98	0.80	0.78	0.55	0.98	0.98	0.84	0.82	0.58
	kW*	4.7	4.7	4.7	4.7	4.8	4.8	4.8	4.8	4.8	4.9	4.9	4.9	4.9	4.9	4.9
115	MBh†	36.9	37.0	37.3	40.2	44.3	38.5	38.5	38.1	41.0	45.1	39.8	39.8	38.7	41.6	45.7
	S/T	0.98	0.98	0.78	0.75	0.54	0.98	0.98	0.82	0.80	0.56	0.98	0.98	0.86	0.84	0.59
	kW*	5.2	5.2	5.2	5.2	5.2	5.2	5.2	5.2	5.3	5.3	5.3	5.3	5.3	5.4	5.4
125	MBh†	-	-	-	-	-	-	-	-	-	-	-	-	-	-	-
	S/T	-	-	-	-	-	-	-	-	-	-	-	-	-	-	-
	kW*	-	-	-	-	-	-	-	-	-	-	-	-	-	-	-

PHF348000K00A (Low Capacity)

OD Ambient (°F)	ID Airflow (SCFM)	950					1100					1250				
		Entering Indoor Temperature - Degrees F, Wet Bulb														
		57	62	63††	67	72	57	62	63††	67	72	57	62	63††	67	72
75	MBh†	29.4	30.3	30.8	33.1	36.3	30.9	31.1	31.5	33.9	37.1	32.1	32.2	32.2	34.5	37.7
	S/T	0.98	0.90	0.72	0.70	0.51	0.98	0.96	0.76	0.73	0.53	0.98	0.98	0.80	0.77	0.55
	kW*	2.1	2.1	2.1	2.2	2.2	2.2	2.2	2.2	2.2	2.3	2.3	2.3	2.3	2.3	2.4
85	MBh†	28.6	29.3	29.8	32.0	35.1	30.0	30.2	30.5	32.7	35.8	31.2	31.3	31.0	33.3	36.4
	S/T	0.98	0.92	0.73	0.71	0.52	0.98	0.97	0.77	0.75	0.54	0.98	0.98	0.81	0.79	0.56
	kW*	2.4	2.4	2.4	2.5	2.5	2.5	2.5	2.5	2.5	2.6	2.6	2.6	2.6	2.6	2.7
95	MBh†	27.8	28.2	28.7	30.8	33.8	29.1	29.2	29.4	31.5	34.5	30.2	30.3	29.9	32.0	35.1
	S/T	0.98	0.94	0.74	0.72	0.52	0.98	0.98	0.78	0.76	0.55	0.98	0.98	0.82	0.80	0.57
	kW*	2.8	2.8	2.8	2.8	2.8	2.8	2.8	2.8	2.9	2.9	2.9	2.9	2.9	3.0	3.0
105	MBh†	26.9	27.1	27.5	29.6	32.5	28.2	28.2	28.2	30.2	33.1	29.2	29.3	28.7	30.7	33.6
	S/T	0.98	0.95	0.75	0.73	0.53	0.98	0.98	0.80	0.78	0.55	0.98	0.98	0.84	0.82	0.58
	kW*	3.1	3.1	3.1	3.2	3.2	3.2	3.2	3.2	3.2	3.3	3.3	3.3	3.3	3.3	3.3
115	MBh†	25.9	26.0	26.3	28.3	31.1	27.1	27.2	26.9	28.9	31.7	28.1	28.2	27.4	29.4	32.1
	S/T	0.98	0.97	0.77	0.75	0.54	0.98	0.98	0.82	0.79	0.56	0.98	0.98	0.86	0.84	0.59
	kW*	3.5	3.5	3.5	3.5	3.6	3.6	3.6	3.6	3.6	3.7	3.7	3.7	3.7	3.7	3.7
125	MBh†	24.9	24.9	25.0	26.9	29.6	26.0	26.1	25.6	27.5	30.1	26.9	27.0	26.0	27.9	30.5
	S/T	0.98	0.98	0.79	0.76	0.55	0.98	0.98	0.84	0.81	0.58	0.98	0.98	0.88	0.86	0.60
	kW*	3.9	3.9	3.9	4.0	4.0	4.0	4.0	4.0	4.0	4.1	4.1	4.1	4.1	4.1	4.2

Notes: When the required data fall between the published data, interpolation may be performed. Extrapolation is not an acceptable practice.

† Total capacities are net capacities. Blower heat has been subtracted

†† At TVA rating indoor condition (75 F db/ 63 F wb), All other indoor air temperatures are at 80 F db

* System kW is total unit kW

Key: Standard Rating

S/T are based on 80°F db entering air at the indoor coil. For sensible capacities at other than 80°F db, deduct 835 Btuh per 1000 cfm of indoor coil air from MBhX/S/T for each degree below 80°F, or add 835 Btuh per 1000 cfm of indoor coil air from MBhX/S/T for each degree above 80°F.

HEATING EXPANDED PERFORMANCE

PHF324000K00A

Return Air (°F db)	CFM (Std. Air)	Air Temperature Entering Outdoor Coil (°F db at 70% rh)																				
		-10	0	10	17	20	30	40	47	50	60											
60	700	TC	7.1	6.6	9.0	8.3	10.9	10.0	12.5	11.4	13.3	12.1	16.3	14.3	19.6	19.6	22.3	22.3	23.3	23.3	26.9	26.9
		kW	1.34	1.40	1.49	1.55	1.57	1.64	1.69	1.73	1.75	1.83										
	800	TC	7.2	6.6	8.9	8.2	11.0	10.1	12.6	11.5	13.4	12.2	16.4	14.4	19.8	19.8	22.4	22.4	23.4	23.4	27.0	27.0
		kW	1.33	1.39	1.48	1.53	1.56	1.61	1.65	1.67	1.69	1.75										
	900	TC	7.2	6.7	9.0	8.3	11.0	10.1	12.6	11.5	13.4	12.2	16.4	14.4	19.8	19.8	22.4	22.4	23.5	23.5	27.0	27.0
		kW	1.32	1.38	1.46	1.52	1.53	1.58	1.61	1.63	1.64	1.69										
70	700	TC	6.8	6.3	8.5	7.9	10.5	9.7	12.1	11.0	12.9	11.7	15.9	13.9	19.2	19.2	21.9	21.9	22.9	22.9	26.5	26.5
		kW	1.44	1.50	1.58	1.65	1.68	1.77	1.85	1.90	1.92	2.01										
	800	TC	6.9	6.4	8.6	7.9	10.6	9.7	12.2	11.1	13.0	11.8	16.0	14.0	19.3	19.3	22.0	22.0	23.0	23.0	26.6	26.6
		kW	1.43	1.48	1.56	1.63	1.66	1.74	1.80	1.84	1.86	1.93										
	900	TC	7.0	6.4	8.6	7.9	14.9	13.7	16.4	15.0	17.5	15.9	21.5	18.8	26.2	26.2	23.1	23.1	26.7	26.7	26.7	26.7
		kW	1.42	1.47	1.55	1.62	1.64	1.71	1.76	1.80	1.81	1.87										
80	700	TC	6.6	6.1	8.4	7.7	10.2	9.3	11.7	10.7	12.6	11.4	15.5	13.6	18.8	18.8	21.4	21.4	22.4	22.4	26.0	26.0
		kW	1.52	1.62	1.69	1.76	1.79	1.90	2.01	2.07	2.10	2.21										
	800	TC	6.7	6.2	8.4	7.8	10.2	9.4	11.8	10.8	12.6	11.5	15.6	13.7	19.0	19.0	21.6	21.6	22.6	22.6	26.2	26.2
		kW	1.51	1.60	1.66	1.74	1.77	1.87	1.96	2.01	2.04	2.12										
	900	TC	6.5	6.0	8.5	7.8	10.3	9.5	11.9	10.8	12.7	11.5	15.7	13.8	19.0	19.0	21.7	21.7	22.7	22.7	26.3	26.3
		kW	1.50	1.59	1.65	1.72	1.75	1.85	1.92	1.97	1.99	2.06										

PHF330000K00A

Return Air (°F db)	CFM (Std. Air)	Air Temperature Entering Outdoor Coil (°F db at 70% rh)																				
		-10	0	10	17	20	30	40	47	50	60											
60	875	TC	9.2	8.5	11.4	10.5	13.8	12.7	15.6	14.2	16.7	15.2	20.8	18.2	24.5	24.5	28.3	28.3	29.6	29.6	34.1	34.1
		kW	1.60	1.69	1.79	1.84	1.87	1.97	2.06	2.15	2.17	2.29										
	1000	TC	9.3	8.6	11.5	10.6	13.9	12.8	15.7	14.3	16.8	15.3	20.9	18.3	24.7	24.7	28.4	28.4	29.7	29.7	35.1	35.1
		kW	1.58	1.68	1.76	1.80	1.83	1.92	2.00	2.08	2.10	2.15										
	1125	TC	9.3	8.6	11.5	10.6	13.9	12.8	15.7	14.3	16.9	15.3	20.1	17.6	24.8	24.8	28.5	28.5	29.7	29.7	34.2	34.2
		kW	1.57	1.66	1.74	1.77	1.80	1.87	1.96	2.03	2.05	2.13										
70	875	TC	9.1	8.4	11.1	10.2	13.5	12.4	15.3	14.0	16.4	14.9	20.5	18.0	25.3	25.3	27.9	27.9	29.1	29.1	33.7	33.7
		kW	1.73	1.80	1.92	1.99	2.04	2.16	2.28	2.36	2.39	2.51										
	1000	TC	9.1	8.4	11.1	10.2	13.6	12.4	15.4	14.0	16.5	15.0	20.6	18.1	25.3	25.3	28.0	28.0	29.3	29.3	33.7	33.7
		kW	1.71	1.78	1.89	1.96	1.99	2.10	2.21	2.28	2.31	2.41										
	1125	TC	9.1	8.4	11.2	10.3	14.9	13.7	16.4	15.0	17.5	15.9	21.5	18.8	26.2	26.2	29.4	29.4	33.7	33.7	33.7	33.7
		kW	1.69	1.77	1.87	1.93	1.97	2.06	2.15	2.22	2.25	2.34										
80	875	TC	8.8	8.2	10.7	9.9	13.1	12.0	14.9	13.6	16.1	14.6	20.2	17.7	24.9	24.9	28.6	28.6	30.4	30.4	33.2	33.2
		kW	1.74	1.94	2.05	2.14	2.19	2.35	2.51	2.63	2.64	2.75										
	1000	TC	9.0	8.4	10.8	9.9	13.2	12.1	15.0	13.7	16.2	14.7	20.3	17.8	25.0	25.0	29.1	29.1	28.9	28.9	33.3	33.3
		kW	1.73	1.91	2.02	2.10	2.16	2.30	2.44	2.50	2.53	2.65										
	1125	TC	9.1	8.4	10.8	10.0	13.2	12.2	15.1	13.8	16.3	14.7	20.4	17.8	25.1	25.1	27.7	27.7	29.0	29.0	33.4	33.4
		kW	1.70	1.89	2.00	2.08	2.14	2.26	2.38	2.45	2.47	2.57										

LEGEND:

- TC - Heating Capacity (1000 Btuh) (Includes Indoor-Fan Motor Heat)
- db - Dry Bulb
- kW - Total Power Input (Includes Compressor Motor Power Input)
- rh - Relative Humidity

NOTES:

- 1 Indicates integrated ratings
- 2 Integrated capacity is maximum (instantaneous) capacity less the effect of frost on the outdoor coil and the heat required to defrost it

HEATING EXPANDED PERFORMANCE

PHF336000K00A

Return Air (°F db)	CFM (Std. Air)	Air Temperature Entering Outdoor Coil (°F db at 70% rh)																				
		-10		0		10		17		20		30		40		47		50		60		
60	1050	TC	10.6	9.8	13.7	12.6	16.8	15.4	19.1	17.4	20.3	18.4	24.9	21.8	30.2	30.2	34.5	34.5	36.2	36.2	42.3	42.3
		kW	1.89		2.00		2.11		2.18		2.22		2.39		2.58		2.72		2.76		2.93	
	1200	TC	10.8	10.0	13.9	12.8	17.0	15.6	19.2	17.5	20.4	18.5	25.1	22.0	30.5	30.5	34.8	34.8	36.5	36.5	42.6	42.6
		kW	1.93		2.04		2.13		2.19		2.23		2.39		2.55		2.68		2.71		2.88	
	1350	TC	11.4	10.5	14.4	13.3	17.4	16.0	19.7	17.9	20.9	18.9	25.6	22.4	31.0	31.0	35.4	35.4	37.3	37.3	41.2	41.2
		kW	2.01		2.13		2.21		2.26		2.30		2.45		2.60		2.70		2.71		2.76	
70	1050	TC	9.7	9.0	13.0	11.9	16.2	14.9	18.6	17.0	19.8	18.0	24.3	21.3	29.4	29.4	33.6	33.6	35.4	35.4	41.3	41.3
		kW	1.98		2.14		2.27		2.36		2.42		2.60		2.81		2.98		3.03		3.20	
	1200	TC	9.8	9.1	13.1	12.1	16.4	15.1	18.8	17.1	20.0	18.2	24.5	21.4	29.7	29.7	34.0	34.0	35.7	35.7	41.7	41.7
		kW	2.02		2.18		2.30		2.38		2.43		2.60		2.79		2.93		2.97		3.13	
	1350	TC	10.3	9.5	13.6	12.5	16.9	15.5	19.3	17.6	20.5	18.6	25.0	21.9	30.2	30.2	34.6	34.6	36.3	36.3	42.3	42.3
		kW	2.12		2.26		2.38		2.45		2.50		2.66		2.83		2.96		2.99		3.15	
80	1050	TC	8.6	7.9	11.8	10.9	15.5	14.2	18.0	16.4	19.2	17.4	23.8	20.8	28.7	28.7	32.8	32.8	34.5	34.5	40.3	40.3
		kW	2.05		2.28		2.44		2.54		2.61		2.84		3.06		3.24		3.30		3.49	
	1200	TC	9.0	8.3	12.2	11.2	15.7	14.4	18.2	16.6	19.5	17.7	23.9	21.0	28.9	28.9	33.1	33.1	34.8	34.8	40.8	40.8
		kW	2.08		2.30		2.46		2.56		2.62		2.83		3.04		3.20		3.25		3.41	
	1350	TC	9.6	8.9	12.7	11.7	16.2	14.9	18.7	17.1	20.0	18.1	24.4	21.4	29.5	29.5	33.7	33.7	35.4	35.4	41.3	41.3
		kW	2.15		2.39		2.54		2.64		2.70		2.89		3.08		3.23		3.27		3.42	

PHF342000K00A

Return Air (°F db)	CFM (Std. Air)	Air Temperature Entering Outdoor Coil (°F db at 70% rh)																				
		-10		0		10		17		20		30		40		47		50		60		
60	1225	TC	13.0	12.0	16.0	14.7	19.2	17.7	21.7	19.8	23.2	21.1	28.6	25.0	34.8	34.8	37.3	37.3	39.1	39.1	45.3	45.3
		kW	2.27		2.40		2.51		2.59		2.64		2.81		2.95		3.07		3.13		3.35	
	1400	TC	13.0	12.1	16.1	14.8	19.3	17.7	21.9	20.0	23.4	21.2	28.8	25.2	34.9	34.9	37.6	37.6	39.4	39.4	45.3	45.3
		kW	2.25		2.37		2.47		2.55		2.60		2.73		2.90		2.99		3.04		3.23	
	1575	TC	13.1	12.1	16.8	15.5	19.4	17.8	22.0	20.1	23.5	21.3	28.9	25.3	33.2	33.2	37.7	37.7	39.4	39.4	45.2	45.2
		kW	2.24		2.35		2.44		2.52		2.56		2.68		2.80		2.92		2.96		3.15	
70	1225	TC	12.3	11.4	15.5	14.3	18.9	17.3	21.3	19.4	22.7	20.6	28.0	24.5	34.0	34.0	38.8	38.8	40.6	40.6	44.7	44.7
		kW	2.40		2.57		2.72		2.81		2.86		3.05		3.24		3.39		3.46		3.64	
	1400	TC	12.4	11.5	15.6	14.4	19.0	17.4	21.4	19.5	22.8	20.7	28.1	24.6	34.3	34.3	39.0	39.0	38.6	38.6	44.8	44.8
		kW	2.39		2.54		2.68		2.76		2.81		2.98		3.13		3.29		3.30		3.51	
	1575	TC	12.5	11.5	15.7	14.5	19.0	17.5	21.5	19.6	22.9	20.8	28.3	24.8	34.4	34.4	37.0	37.0	38.8	38.8	44.8	44.8
		kW	2.38		2.52		2.65		2.73		2.77		2.92		3.08		3.17		3.23		3.42	
80	1225	TC	11.2	10.4	14.8	13.6	18.4	16.9	21.0	19.1	22.3	20.2	27.4	24.0	33.3	33.3	38.1	38.1	39.9	39.9	44.0	44.0
		kW	2.49		2.74		2.93		3.05		3.11		3.31		3.53		3.68		3.75		3.96	
	1400	TC	11.4	10.5	15.0	13.8	19.0	17.4	21.1	19.2	22.4	20.3	27.6	24.2	33.6	33.6	38.3	38.3	40.1	40.1	44.2	44.2
		kW	2.48		2.72		2.89		3.00		3.05		3.24		3.43		3.57		3.64		3.82	
	1575	TC	11.5	10.6	15.1	13.9	18.7	17.1	21.1	19.3	22.5	20.4	27.7	24.3	33.7	33.7	38.9	38.9	40.9	40.9	44.7	44.7
		kW	2.48		2.70		2.86		2.96		3.01		3.18		3.35		3.44		3.47		3.63	

LEGEND:

- TC - Heating Capacity (1000 Btuh) (Includes Indoor-Fan Motor Heat)
- db - Dry Bulb
- kW - Total Power Input (Includes Compressor Motor Power Input)
- rh - Relative Humidity

NOTES:

- 1 Indicates integrated ratings
- 2 Integrated capacity is maximum (instantaneous) capacity less the effect of frost on the outdoor coil and the heat required to defrost it

HEATING EXPANDED PERFORMANCE

PHF348000K00A (High Capacity)

Return Air (°F db)	CFM (Std. Air)	Air Temperature Entering Outdoor Coil (°F db at 70% rh)																				
		-10		0		10		17		20		30		40		47		50		60		
60	1400	TC	13.7	12.6	17.3	15.9	21.4	19.7	24.6	22.4	26.3	23.8	32.4	28.3	39.1	39.1	44.5	44.5	46.7	46.7	54.5	54.5
		kW	2.54		2.70		2.85		2.95		2.99		3.18		3.36		3.50		3.58		3.87	
	1600	TC	14.1	13.0	17.8	16.3	21.9	20.1	25.1	22.8	26.7	24.2	32.8	28.7	39.7	39.7	45.0	45.0	47.2	47.2	55.0	55.0
		kW	2.60		2.74		2.87		2.97		3.02		3.18		3.34		3.46		3.53		3.82	
	1800	TC	14.4	13.3	18.1	16.6	22.2	20.4	25.4	23.1	27.0	24.5	33.1	29.0	40.0	40.0	45.3	45.3	47.7	47.7	52.5	52.5
		kW	2.63		2.76		2.89		2.98		3.03		3.18		3.31		3.43		3.44		3.59	
70	1400	TC	12.6	11.7	16.4	15.1	20.5	18.8	23.7	21.6	25.4	23.0	31.5	27.6	38.2	38.2	43.4	43.4	45.6	45.6	53.3	53.3
		kW	2.68		2.89		3.08		3.20		3.25		3.46		3.68		3.84		3.92		4.22	
	1600	TC	13.1	12.1	16.9	15.6	21.0	19.3	24.2	22.1	25.9	23.5	32.0	28.0	38.7	38.7	44.0	44.0	46.2	46.2	53.9	53.9
		kW	2.74		2.94		3.11		3.22		3.27		3.46		3.66		3.79		3.87		4.16	
	1800	TC	13.4	12.4	17.2	15.8	21.3	19.6	24.5	22.4	26.2	23.8	32.3	28.3	39.0	39.0	44.4	44.4	46.5	46.5	54.3	54.3
		kW	2.78		2.96		3.12		3.23		3.28		3.46		3.63		3.75		3.82		4.11	
80	1400	TC	11.4	10.5	15.4	14.2	19.6	17.9	22.7	20.7	24.3	22.0	30.4	26.6	37.2	37.2	42.4	42.4	44.5	44.5	52.1	52.1
		kW	2.79		3.07		3.30		3.45		3.51		3.73		4.01		4.19		4.28		4.60	
	1600	TC	11.8	10.9	15.8	14.6	20.1	18.4	23.2	21.1	24.8	22.5	30.9	27.1	37.7	37.7	42.9	42.9	45.1	45.1	52.8	52.8
		kW	2.85		3.12		3.34		3.48		3.53		3.74		3.99		4.15		4.23		4.49	
	1800	TC	12.1	11.2	16.2	14.9	20.4	18.7	23.5	21.4	25.2	22.9	31.4	27.5	38.1	38.1	43.3	43.3	45.5	45.5	53.1	53.1
		kW	2.89		3.15		3.36		3.49		3.54		3.74		3.96		4.11		4.18		4.46	

PHF348000K00A (Low Capacity)

Return Air (°F db)	CFM (Std. Air)	Air Temperature Entering Outdoor Coil (°F db at 70% rh)																				
		-10		0		10		17		20		30		40		47		50		60		
60	950	TC	10.5	9.7	13.0	11.9	15.7	14.4	17.8	16.2	19.0	17.2	23.6	20.6	27.7	27.7	31.8	31.8	33.3	33.3	38.4	38.4
		kW	2.04		2.16		2.28		2.34		2.37		2.44		2.49		2.56		2.59		2.72	
	1100	TC	10.6	9.8	13.1	12.0	15.8	14.5	17.8	16.2	19.1	17.3	23.6	20.7	27.8	27.8	32.0	32.0	33.4	33.4	39.4	39.4
		kW	2.02		2.14		2.25		2.30		2.32		2.37		2.42		2.47		2.50		2.56	
	1250	TC	10.6	9.8	13.1	12.1	15.8	14.5	17.9	16.3	19.1	17.4	22.7	19.9	27.9	27.9	32.0	32.0	33.4	33.4	38.5	38.5
		kW	2.00		2.12		2.22		2.26		2.27		2.31		2.37		2.41		2.44		2.54	
70	950	TC	10.3	9.5	12.6	11.6	15.3	14.1	17.4	15.9	18.7	16.9	23.2	20.3	28.5	28.5	31.4	31.4	32.8	32.8	37.9	37.9
		kW	2.21		2.30		2.44		2.54		2.58		2.67		2.76		2.81		2.84		2.99	
	1100	TC	10.3	9.5	12.6	11.6	15.4	14.1	17.5	16.0	18.7	17.0	23.3	20.4	28.6	28.6	31.5	31.5	32.9	32.9	38.0	38.0
		kW	2.18		2.27		2.41		2.50		2.52		2.60		2.68		2.72		2.75		2.87	
	1250	TC	10.3	9.5	12.7	11.7	14.9	13.7	16.4	15.0	17.5	15.9	21.5	18.8	26.2	26.2	33.0	33.0	38.0	38.0	38.0	38.0
		kW	2.15		2.25		2.39		2.46		2.49		2.55		2.60		2.65		2.68		2.79	
80	950	TC	10.0	9.3	12.2	11.2	14.9	13.7	17.0	15.5	18.2	16.5	22.8	20.0	28.1	28.1	32.2	32.2	34.2	34.2	37.3	37.3
		kW	2.22		2.47		2.61		2.73		2.77		2.91		3.04		3.13		3.15		3.28	
	1100	TC	10.3	9.5	12.3	11.3	15.0	13.7	17.1	15.6	18.3	16.6	22.9	20.1	28.2	28.2	32.7	32.7	32.5	32.5	37.5	37.5
		kW	2.20		2.43		2.57		2.68		2.73		2.85		2.95		2.98		3.02		3.15	
	1250	TC	10.3	9.5	12.3	11.3	15.0	13.8	17.2	15.6	18.5	16.7	23.0	20.2	28.3	28.3	31.2	31.2	32.6	32.6	37.5	37.5
		kW	2.17		2.41		2.55		2.66		2.70		2.79		2.88		2.91		2.94		3.06	

LEGEND:

- TC - Heating Capacity (1000 Btuh) (Includes Indoor-Fan Motor Heat)
- db - Dry Bulb
- kW - Total Power Input (Includes Compressor Motor Power Input)
- rh - Relative Humidity

NOTES:

- 1 Indicates integrated ratings
- 2 Integrated capacity is maximum (instantaneous) capacity less the effect of frost on the outdoor coil and the heat required to defrost it

ELECTRIC HEATER USAGE CHART

EHA Heater Model No's (Example: EHA05KN)								
Without Circuit Breakers	05KN		07KN		10KN			
With Circuit Breakers		05KB		07KB		10KB	15KB	20KB
Unit kW	5kW		7.5kW		10kW		15kW	20kW
PHF3	USED ON							
24	X	X	X	X		X		
30	X	X		X		X	X	
36	X	X		X		X	X	X
42	X	X		X		X	X	X
48		X		X		X	X	X

PHF3 - ELECTRICAL DATA: ELECTRIC HEAT ACCESSORY

Heater Model	Use With	Supply Voltage	KW Rating	Nominal Heating BTUH	Supply Circuit No.	Heater Amps	Minimum Circuit Ampacity	Maximum Overcurrent Protective Device (Amps)
EHA05KB	2 to 4 Ton	240-1-60	5.0	17,065	L3 - L4	20.8	26.0	30
		208-1-60	3.75	12,798	L3 - L4	18.0	22.5	25
EHA05KN	2 to 3-1/2 Ton	240-1-60	5.0	17,065	L3 - L4	20.8	26.0	30
		208-1-60	3.75	12,798	L3 - L4	18.0	22.5	25
EHA07KB	2 to 4 Ton	240-1-60	7.5	25,598	L3-L4	31.3	39.1	40
		208-1-60	5.6	19,113	L3-L4	27.1	33.9	35
EHA07KN	2 Ton	240-1-60	7.5	25,598	L3-L4	31.3	39.1	40
		208-1-60	5.6	19,113	L3-L4	27.1	33.9	35
EHA10KB	2 to 4 Ton	240-1-60	10.0	34,130	L3 - L4	41.7	52.1	60
		208-1-60	7.5	25,598	L3 - L4	36.2	45.3	45
EHA15KB	2-1/2 to 4 Ton	240-1-60	15.0	51,195	L3 - L4	41.7	52.1	60
					L5 - L6	20.8	26.0	30
		208-1-60	11.25	38,567	L3 - L4	36.2	45.3	45
					L5 - L6	18.0	22.5	25
EHA20KB	3 to 4 Ton	240-1-60	20	68,260	L3 - L4	41.7	52.1	60
					L5 - L6	41.7	52.1	60
		208-1-60	15.0	51,195	L3 - L4	36.2	45.3	45
					L5 - L6	36.2	45.3	45

PHF3 - PERFORMANCE DATA: ELECTRIC HEAT ACCESSORY

Heater Model	Use With	Supply Voltage	KW Rating	Total Heating BTUH	*Temperature Rise °F @ CFM								
					600	800	1000	1200	1400	1600	1800	2000	2200
EHA05KB	2 to 4 Ton	240-1-60	5.0	17,065	26.4	19.8	15.8	13.1	11.2	9.9	8.7	7.9	-
		208-1-60	3.75	12,798	19.8	14.8	11.9	9.9	8.4	7.4	6.6	5.9	-
EHA05KN	2 to 3-1/2 Ton	240-1-60	5.0	17,065	26.4	19.8	15.8	13.1	11.2	9.9	8.7	7.9	-
		208-1-60	3.75	12,798	19.8	14.8	11.9	9.9	8.4	7.4	6.6	5.9	-
EHA07KB	2 to 4 Ton	240-1-60	7.5	25,598	39.5	29.6	23.7	19.8	16.9	14.8	13.2	11.9	10.8
		208-1-60	5.6	19,113	29.5	22.1	17.7	14.7	12.6	11.1	9.8	8.8	8.0
EHA07KN	2 Ton	240-1-60	7.5	25,598	39.5	29.6	23.7	19.8	16.9	14.8	13.2	11.9	10.8
		208-1-60	5.6	19,113	29.5	22.1	17.7	14.7	12.6	11.1	9.8	8.8	8.0
EHA10KB	2 to 4 Ton	240-1-60	10.0	34,130	52.7	39.5	31.6	26.4	22.6	19.8	17.6	15.8	14.4
		208-1-60	7.5	25,598	39.5	29.6	23.7	19.8	17.0	14.8	13.1	11.9	10.7
EHA15KB	2-1/2 to 4 Ton	240-1-60	15.0	51,195	-	59.3	47.4	39.5	33.9	29.6	26.4	23.7	21.2
		208-1-60	11.25	38,567	59.3	44.5	35.5	27.3	25.4	22.2	19.8	17.8	16.1
EHA20KB	3 to 4 Ton	240-1-60	20.0	68,260	-	-	-	52.7	45.1	39.5	35.1	31.6	28.7
		208-1-60	15.0	51,195	-	59.3	47.4	39.5	33.9	29.6	26.4	23.7	21.2

ACCESSORIES

ROOF CURBS

Model Number	Height (K)	Use With
ACL01FB0A	8"	PHF3 - ALL MODELS
ACM01FB0A	14"	
ACH01FB0A	24"	

ROOF CURB DIMENSIONS (inches)

Model Number	A	B	C	D	E	F	G	H	K (ACL)	K (ACM)	K (ACH)
AC(L,M,H)01FB0A	42-1/2	39-1/2	16	21-1/2	2	45-3/4	42-3/4	20	8	14	24

NOTE: AXB020(L,M,H)A curb can be substituted for AC(L,M,H)01FB0A.

SQUARE to ROUND TRANSITION

Model Number	Round Size	Use With Roof Curb
ACT01FB0A	16"	ACL01FB0A, ACM01FB0A, ACH01FB0A

CONCENTRIC GRILLE - FLUSH MOUNT

Model Number	Use With Roof Curb
AXB020CFA	ACL01FB0A, ACM01FB0A, ACH01FB0A

CONCENTRIC GRILLE - STEP DOWN

Model Number	Use With Roof Curb
AXB020CSA	ACL01FB0A, ACM01FB0A, ACH01FB0A

Curb Dimensions

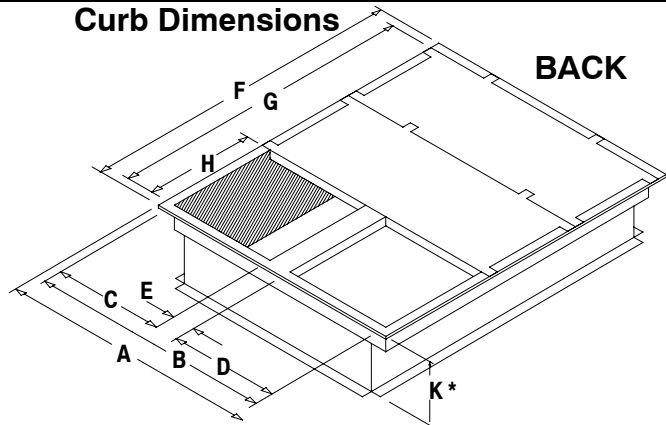

Roof Curbs available in 8", 14" and 24" Heights (K Dimensions)

ECONOMIZERS (ALL FULLY MODULATING)*

Model Number	Application	Motion	Control	Use With Model Size
AHE01FB0A	Horizontal	Fully Modulating w/ Return Air Damper w/ Relief Damper	Enthalpy	24
AHE02FB0B				30, 36, 42, 48
AEM01FB0A	Downflow			24
AEM03FB0B				30, 36, 42, 48
AHP01FB0B	Horizontal	Fully Modulating w/ Return Air Damper w/ Relief Damper	Dry Bulb Only	24
AHP02FB0B				30, 36, 42, 48
AEP01FB0B	Downflow			24
AEP03FB0B				30, 36, 42, 48

* Three position economizers no longer available.

0% - 35% FRESH AIR DAMPERS (use in DOWN-FLOW application) *

Model Number	Control	Use With Model Size
AFA01FB0A	Manual	24
AFA02FB0A		30, 36, 42, 48, 54
AFM01FB0A	Motorized	24
AFM02FB0A		30, 36, 42, 48, 54

* Unit must have internal filters to protect evaporator coil when Fresh Air Damper is installed.

OUTDOOR THERMOSTAT

Model Number	Description	Use With Model Size
AMF002OTA	2 Stage, Electronic	ALL

FILTER KIT, INTERNAL (use in HORIZONTAL or DOWNFLOW application)

Model Number	Filter Size (filters NOT supplied in kit)	Use With Model Size
AKF12FB0A	12 x 25 x 1 (2 required)	24
	14 x 25 x 1 (2 required)	30, 36, 42, 48, 54

HAIL GUARD

Model Number	Use With Model Size
AGH01FB0A	24
AGH02FB0A	30, 36, 42, 48, 54

LOW AMBIENT CONTROL

Model Number	FAST Part Number	Use With
ALA12CU0A	1085493	ALL

UNIT DIMENSIONS

2 TO 4 TON

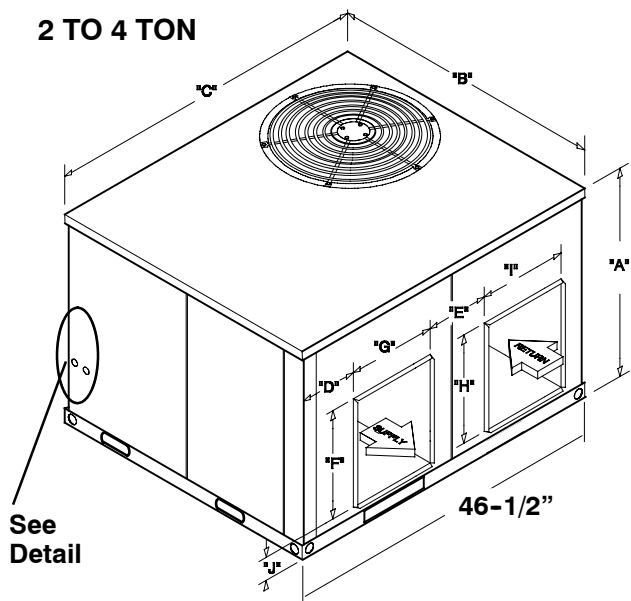

See Detail

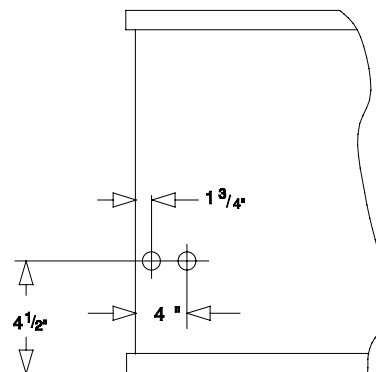

BASE PAN - CHASSIS

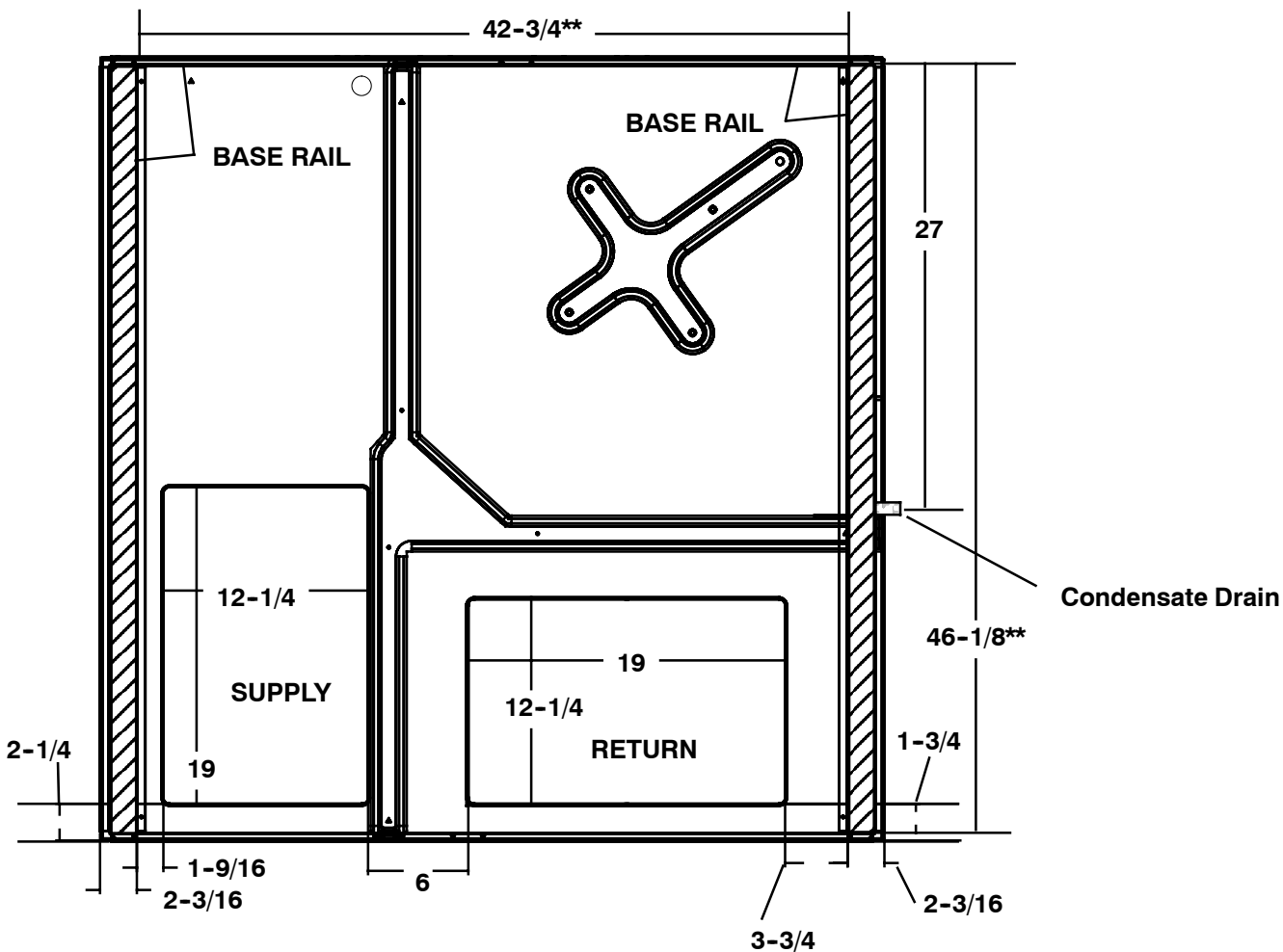

UNIT SIZE	A	B	C	D	E	F	G	H	I	J
2 Ton	29-1/2	47-1/2	47-1/2	3	9-1/2	12	14	12	14	4-1/2
2-1/2 to 4 Ton	37-1/2	47-1/2	47-1/2	4	6-1/2	19	12	12	19	4-1/2

** Measured from inside to inside on base rails.

MODEL NUMBER IDENTIFICATION GUIDE

Product Family	SEER	Nominal Cooling Capacity Btuh	Heating Input Btuh	Voltage	Option Code	Design Code	Eng. Rev. Code
PHF - Package Heat Pump	3 = 13	24 = 24,000	000 = N/A	K = 208/230-1-60	00 = N/A	A	1
		30 = 30,000					
		36 = 36,000					
		42 = 42,000					
		48 = 48,000					
Example: PHF	3	24	000	K	00	A	1

GUIDE SPECIFICATION

CABINET

The cabinet is made of triple-coated steel, consisting of a Polyester top coat, a urethane primer coat preceded by an oxide pretreatment. One piece weather resistant top. The base rails are 16 gauge steel with fork lift slots and holes provided for lifting shackles. The unit is designed with convertible airflow for either horizontal or downflow applications with conversion accomplished by relocating two panels. Indoor blower compartment interior cabinet surfaces are insulated with a minimum 1/2" thick, flexible glass insulation, coated on the air side.

COOLING SECTION

The unit is factory charged and operationally ready upon delivery. The unit refrigerant circuit has a high efficiency scroll compressor with internal overload protection, and copper tube / aluminum fin evaporator and condenser coils. The unit is designed for cooling operation to 40° F and will be capable of being wired for field installed economizer type accessories.

COILS

The evaporator and condenser coils are fabricated with aluminum fins mechanically bonded to copper tubing. Both coils are pressure tested prior to assembly into the unit and electronically leak tested after assembly into the unit.

CONDENSER FAN

The unit has a single direct-drive propeller-fan / motor assembly. The assembly is mounted directly to a vertical-discharge grille that is easily removed for service. Motors are 1100 RPM with sleeve or ball bearings and internal overload protection.

EVAPORATOR BLOWER

All units have a direct-drive evaporator blower motor as a standard. The direct-drive evaporator blower motor has sleeve bearings and internal overload protection.

RIGGING DETAILS

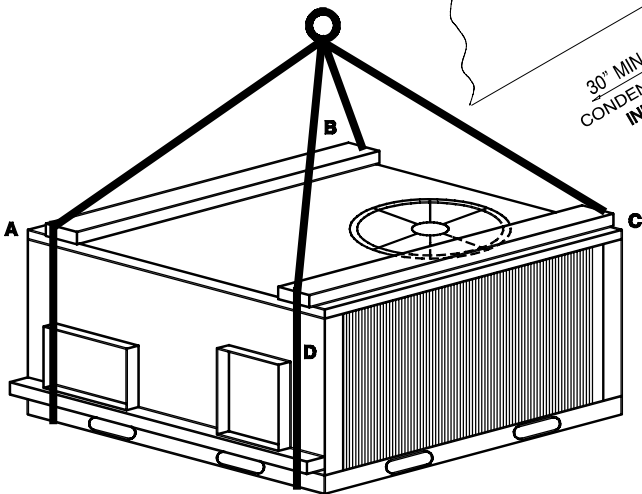

INSTALLATION CLEARANCES

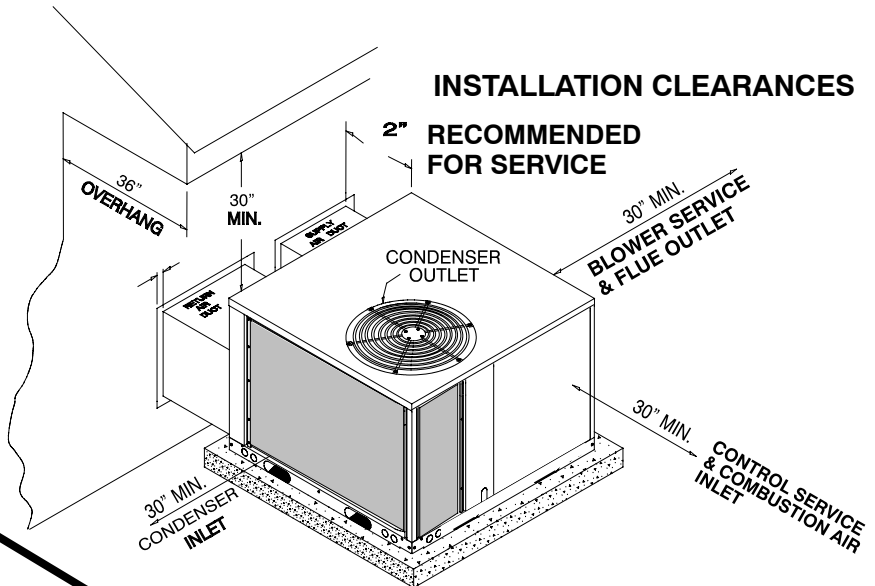

OPERATING WEIGHTS (LBS)

UNIT SIZE	OPERATING WEIGHT TOTAL
2 TON	270
2-1/2 TON	305
3 TON	312
3-1/2 TON	335
4 TON	385