

Installation Instructions

PAX4 Series PACKAGE AIR CONDITIONERS



TABLE OF CONTENTS

UNIT DIMENSIONS	2 - 4	DUCTWORK	8
SAFE INSTALLATION REQUIREMENTS	5	FILTERS	8
LOCATING THE UNIT	5	AIRFLOW ADJUSTMENT	9
CLEARANCES	5	START-UP PROCEDURES	9
INSTALLATION	6	SEQUENCE OF OPERATION	9
GROUND LEVEL INSTALLATION	6	TROUBLE SHOOTING	10
Rooftop INSTALLATION	6	SYSTEM CHARGING	10
HOISTING	6	MAINTENANCE	11
DOWNFLOW CONVERSION	6	RIGGING	13
CONDENSATE DRAIN	6	WIRING DIAGRAMS	14
ELECTRICAL WIRING	7		

1. Unit Dimensions

"B" CHASSIS UNIT DIMENSIONS

PACKAGE AIR CONDITIONER UNITS "B" Chassis (47³/₈ x 47³/₈)

DIM.	INCHES	MILLIMETERS
A	32-1/2	826
B	47-3/8	1203
C	47-3/8	1203
D	3-1/8	79
E	11-1/8	283
F	12	306
G	14-1/4	363
H	14-1/4	363
I	12	306
J	4	102
K	3/4 & 1	19 & 25
L	4-1/4	108
M	4-3/8	111
N	14-1/2	368
P	12-1/4	311
Q	12-1/8	308
R	14-1/4	363
S	12-1/4	318

Units in "B" Chassis Configuration
PAX424 - 30

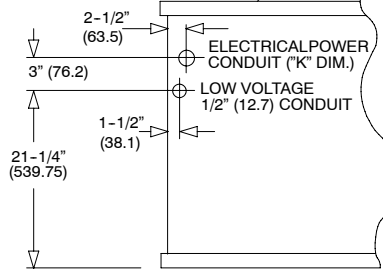
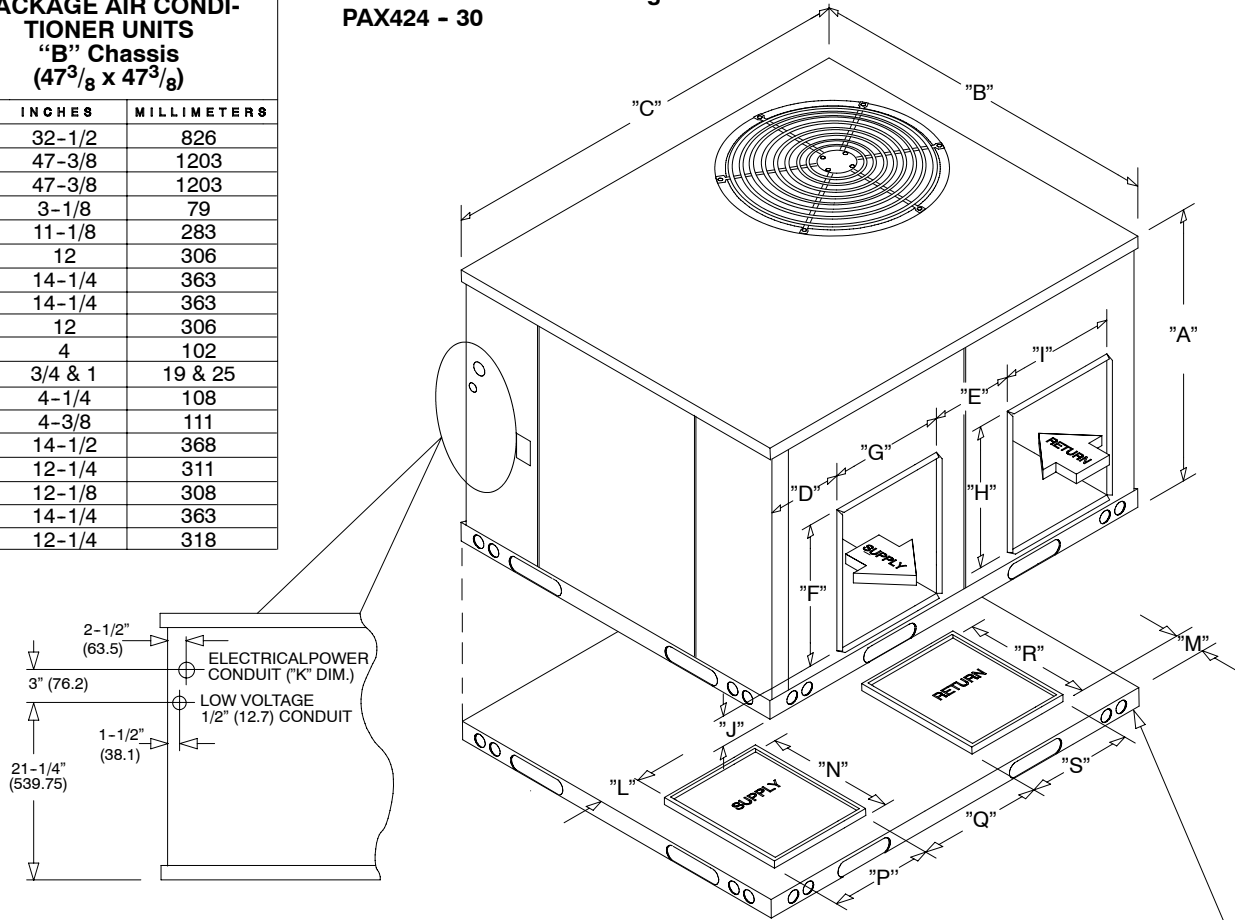

UNIT BASE SHOWN SEPARATELY
TO ILLUSTRATE BOTTOM
DUCT OPENINGS

ROOF CURB for units in "B" Chassis (47³/₈ x 47³/₈)

DIM.	INCHES	MILLIMETERS
A	42-3/4	1086
B	39-3/4	1010
C	18	457
D	18	457
E	3-3/4	95
F	42-3/4	1086
G	39-3/4	1010
H	18	457
K*	14	356

Units in "B" Chassis Configuration
PAX424 - 30

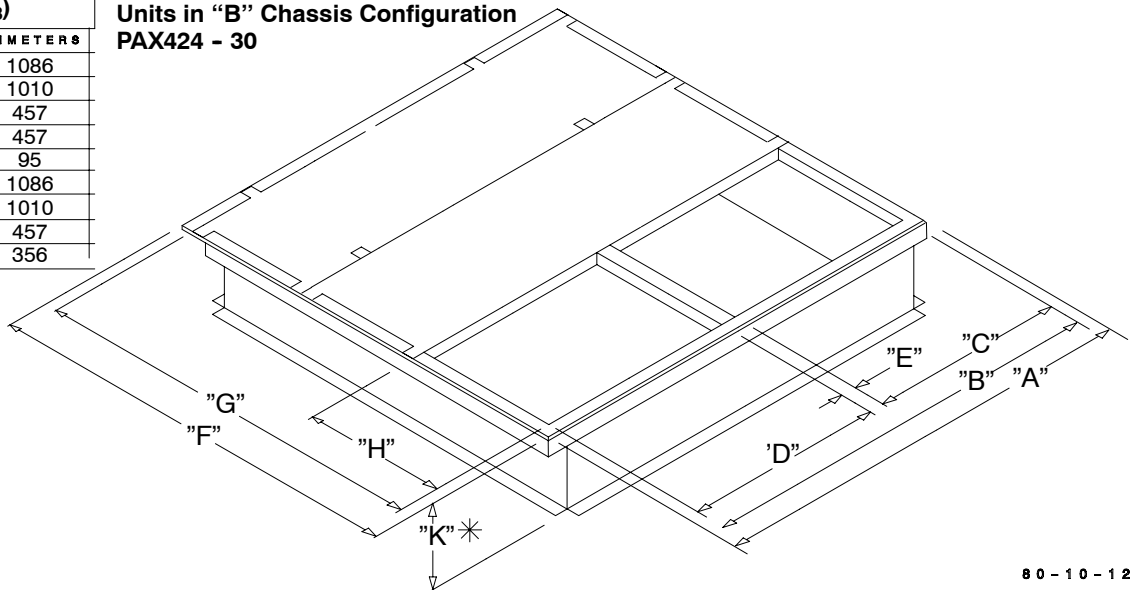

* Roof curbs are also available in 8" and 24" heights (K Dimensions).

80-10-12

"C" CHASSIS UNIT DIMENSIONS

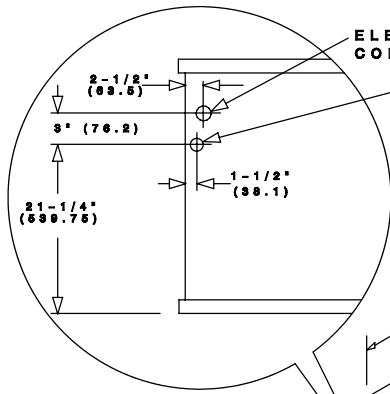

ELECTRICAL POWER CONDUIT ('K' DIM.)
LOW VOLTAGE 1/2" (12.7) CONDUIT

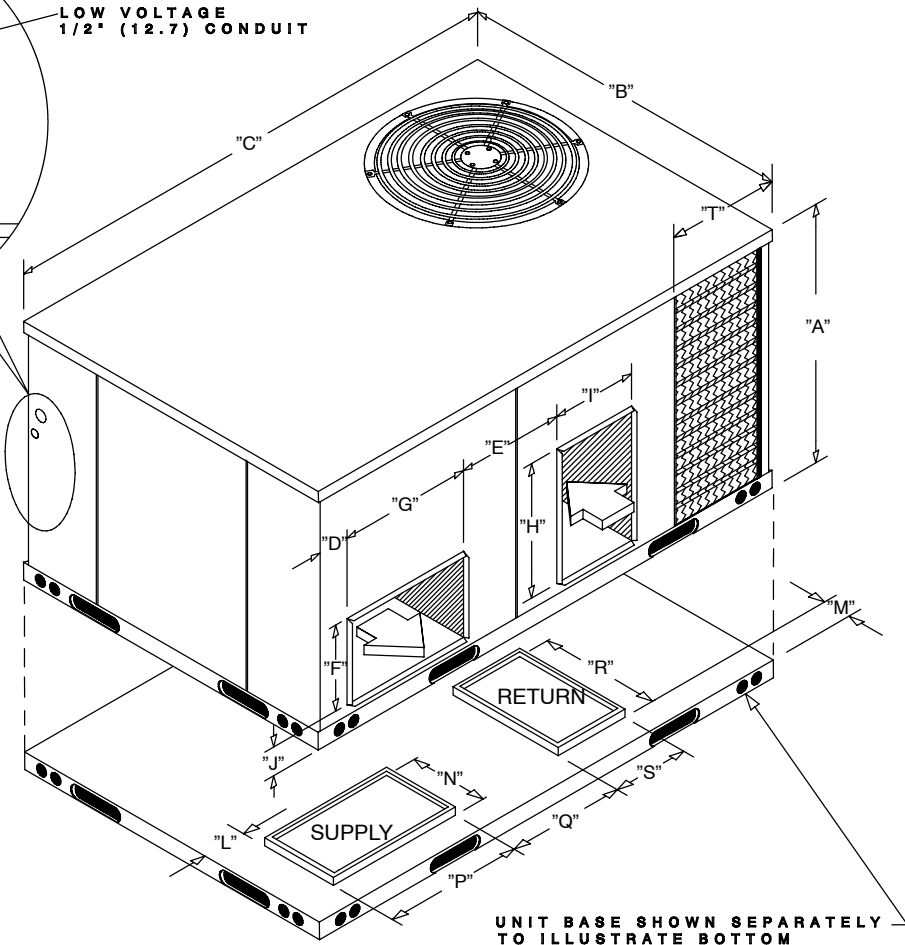

PACKAGE AIR CONDITIONER UNITS "C" Chassis (47³/₈ x 73)

DIM.	INCHES	MILLIMETERS
A	36	914
B	47-3/8	1203
C	73	1354
D	4-5/8	117
E	15	361
F	12	307
G	18-3/4	476
H	18-3/4	476
I	12	306
J	4	102
K	1 & 1-1/4	25 & 31
L	4-1/4	108
M	5-1/4	133
N	12-1/4	311
P	19	483
Q	15	381
R	19	483
S	12-1/4	318
T	16-7/8	429

ROOF CURB for "C" Chassis (47³/₈ x 73)

DIM.	INCHES	MILLIMETERS
A	67-3/4	1721
B	64-3/4	1645
C	23	584
D	23	584
E	2-1/2	64
F	42-3/4	1086
G	39-3/4	1010
H	23	584
I	12	305
J	12	305
K*	14	356

Units in "C" Chassis Configuration PAX436-42

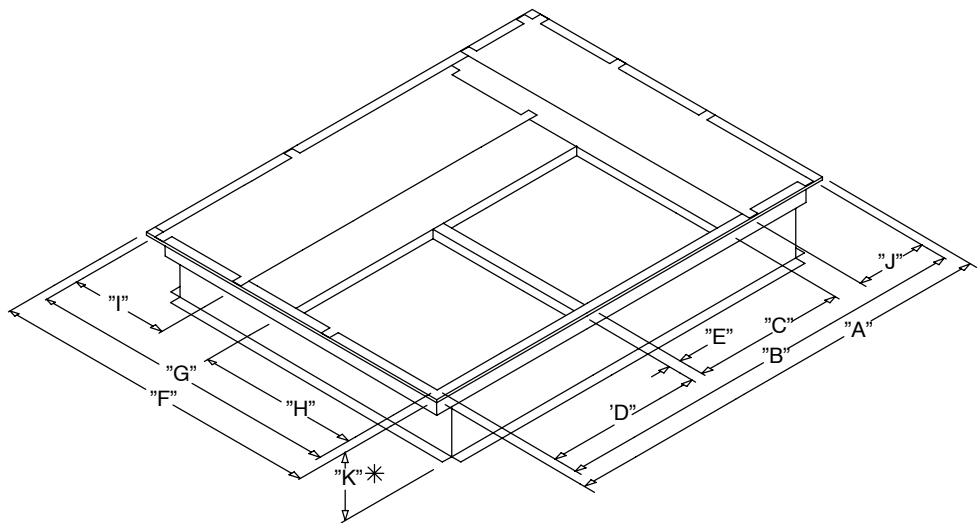

* ROOF CURBS ARE ALSO AVAILABLE IN 8'(203) AND 24'(610) HEIGHTS (K DIMENSION).

"C+" CHASSIS UNIT DIMENSIONS

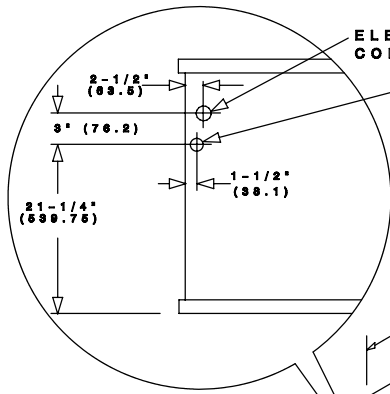

ELECTRICAL POWER CONDUIT (*K* DIM.)
 LOW VOLTAGE 1/2" (12.7) CONDUIT

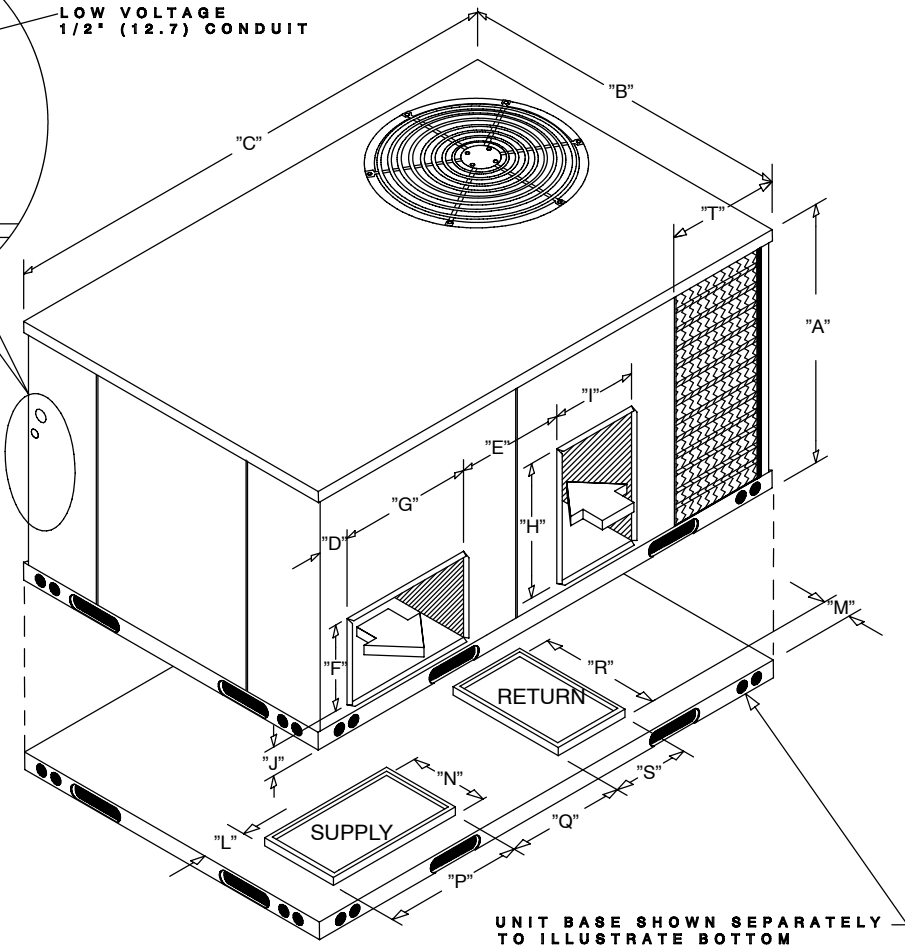

PACKAGE AIR CONDITIONER UNITS "C" Chassis (47³/₈ x 73)

DIM.	INCHES	MILLIMETERS
A	42	1016
B	47-3/8	1203
C	73	1354
D	4-5/8	117
E	15	361
F	12	307
G	18-3/4	476
H	18-3/4	476
I	12	306
J	4	102
K	1 & 1-1/4	25 & 31
L	4-1/4	108
M	5-1/4	133
N	12-1/4	311
P	19	483
Q	15	381
R	19	483
S	12-1/4	318
T	16-7/8	429

ROOF CURB for "C" Chassis (47³/₈ x 73)

DIM.	INCHES	MILLIMETERS
A	67-3/4	1721
B	64-3/4	1645
C	23	584
D	23	584
E	2-1/2	64
F	42-3/4	1086
G	39-3/4	1010
H	23	584
I	12	305
J	12	305
K*	14	356

Units in "C" Chassis Configuration PAX448-60

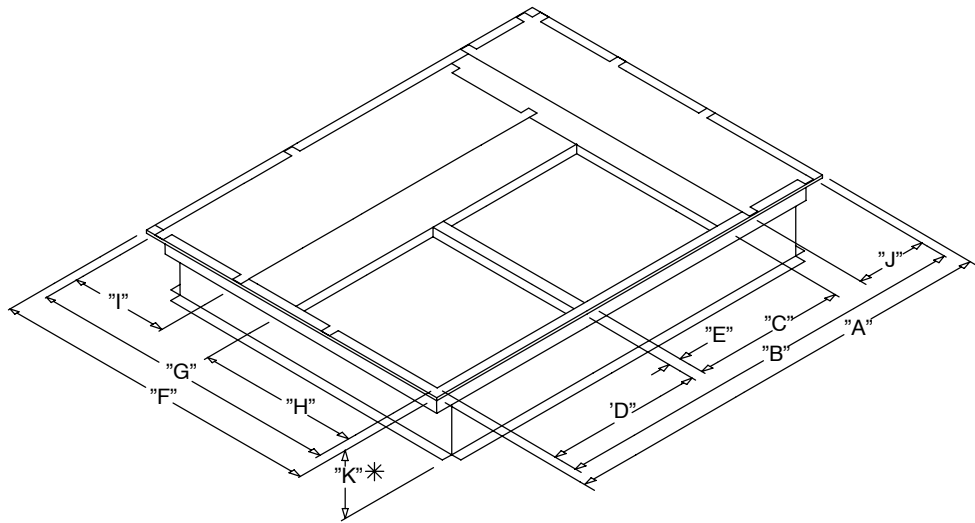

* ROOF CURBS ARE ALSO AVAILABLE IN 8'(203) AND 24'(610) HEIGHTS (K DIMENSION).

2. SAFE INSTALLATION REQUIREMENTS

Installation and servicing of air-conditioning equipment can be hazardous due to system pressure and electrical components. Only trained and qualified personnel should install, repair, or service air-conditioning equipment.

Untrained personnel can perform basic maintenance functions of cleaning coils and filters. All other operations should be performed by trained service personnel. When working on air-conditioning equipment, observe precautions in the literature, tags, and labels attached to the unit, and other safety precautions that may apply.

Follow all safety codes. Wear safety glasses and work gloves. Use quenching cloth for unbrazing operations. Have fire extinguisher available for all brazing operations.

⚠ WARNING

FIRE AND ELECTRICAL SHOCK HAZARD

Improper installation, adjustment, alteration, service, maintenance, or use can cause fire or an explosion which could result in personal injury or unit damage. Consult a qualified installer or service agency for information or assistance. The qualified installer or agency must use only factory-authorized kits or accessories when modifying this product.

⚠ WARNING

FIRE, AND ELECTRICAL SHOCK HAZARD

Failure to follow this warning could result in personal injury, death and/or property damage.

Before performing service or maintenance operations on unit, turn off unit main power switch and install lockout tag.

Recognize safety information. This is the safety-alert symbol . When you see this symbol in instructions or manuals, be alert to the potential for personal injury.

Understand the signal words **DANGER**, **WARNING**, **CAUTION**, and **NOTE**. These words are used with the safety-alert symbol. **DANGER** identifies the most serious hazards which **will** result in serious injury or death. **WARNING** signifies a hazard which **could** result in serious injury or death. **CAUTION** is used to identify unsafe practices which **may** result in minor personal injury or product and property damage. **NOTE** is used to highlight suggestions which **will** result in enhanced installation, reliability, or operation.

⚠ WARNING

FIRE, AND ELECTRICAL SHOCK HAZARD

Failure to carefully read and follow all instructions in this manual could result in personal injury, death and/or property damage.

Installation or repairs made by unqualified persons can result in hazards to you and others. Installation **MUST** conform with local building codes or, in the absence of local codes, with the National Electrical Code NFPA70-2005 or in Canada the CSA C.22.1 - Canadian Electrical Code Part 1.

The information contained in this manual is intended for use by a qualified service technician familiar with safety procedures and equipped with the proper tools and test instruments.

SAFETY CONSIDERATIONS

- Install this unit only in a location and position as specified in section 3 of this manual.
- Always install unit to operate within the unit's intended external static pressure within the allowable range, as specified in section 6. Refer to unit rating plate for the allowable external static pressures.
- All connecting ductwork to the unit (supply and return) must be sealed to the unit casing as specified in section 5.
- Check to see that filters are installed correctly and are the proper type and size.

NOTE: It is the personal responsibility and obligation of the customer to contact a qualified installer to ensure that the installation is adequate and conforms to governing codes and ordinances.

INTRODUCTION

The PAX4 unit is a fully self-contained, electric cooling unit designed for outdoor installation (See pages 2-4 for unit dimensions). All unit sizes have return and discharge openings for both horizontal and downflow configurations, and are factory-shipped with all downflow duct openings covered.

Units may be installed either on a rooftop, cement slab, or directly on the ground if local codes permit.

3. LOCATING THE UNIT

ACCESS PANELS

See **Figure 1** for a general view of unit and location of access panels.

CLEARANCES

The location **MUST** allow for minimum clearances and should not be adjacent to a patio or other area where the unit's operating sound level might be objectionable. The combustion air inlet openings **MUST** not be obstructed (see **Figure 1**). In addition, local codes **MUST** be observed.

NOTE: Units with available filter racks (3 to 5 ton), need a 30" (762mm) minimum clearance at side of unit for removal of filters. See Minimum Clearances below if unit is going to be placed near combustible construction or materials.

While minimum clearances are acceptable for safety reasons, they may not allow adequate air circulation around the unit for proper operation in the cooling mode. Whenever possible, it is desirable to allow additional clearance, especially around the condenser inlet and discharge openings.

Do **NOT** install the unit in a location that will permit discharged air from the condenser to recirculate to the condenser inlet.

⚠ CAUTION

UNIT DAMAGE HAZARD

Failure to follow this caution may result in shorten life of unit components.

Do **NOT** operate unit in a corrosive atmosphere containing chlorine, fluorine, or any other corrosive chemicals.

Minimum Clearances to Combustible Construction

	Inch	mm
Duct Side	2	51
Condenser Inlet	30	762
Blower Service (Side)	30	762
Control Service Side (Front Combustion Air Inlet)	30	762
Clearance between 3 Ft. Overhang and Top of Unit	30	762
Combustible Base (Wood or Class A, B or C roof covering material)	0	0

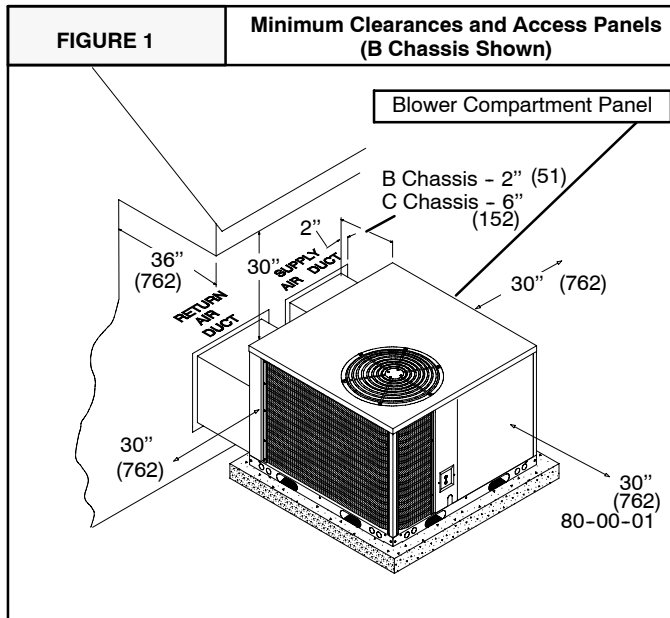

INSTALLATION

NOTICE

Unit will **NOT** operate properly unless it is installed level front to rear and side to side. The slope **MUST NOT** be greater than 1/8" per foot (10mm per meter). For side to side leveling, the drain side **MUST** always be lower.

Ground Level Installation

Ground level platform requirements:

- The unit **MUST** be situated to provide safe access for servicing.
- Platform may be made of either concrete or pressure treated wood and **MUST** be level and strong enough to support unit weight.
- Position platform separate from building foundation.
- Install in well-drained area, with top surface of platform above grade level.

- Platform must be high enough to allow for proper condensate trap installation and drainage. See **Figure 2** and associated text for more information about condensate drainage.

Rooftop Installation

Rooftop platform requirements:

- The unit **MUST** be situated to provide safe access for servicing.
- The existing roof structure **MUST** be adequate to support the weight of the unit or the roof **MUST** be reinforced.
Check the weight of the unit in relation to the roof structure and local building codes or ordinances and reinforce roof structure if necessary.
- Support for the unit **MUST** be level and strong enough to carry unit weight. The support may consist of a platform or a combination of platform and roof beams or curb.

HOISTING

NOTE: All access panels **MUST** be secured in place before hoisting.

The unit should be hoisted with two lifting slings. Attach the slings to rigging shackles that have been hooked through holes in the base rail.

Two spreader bars **MUST** be placed on top of the unit to protect the unit from damage from the pressure exerted by the slings. Make sure that all equipment is adequate to handle the weight of the unit and that the slings will not allow the unit to shift.

Refer to **Figure 7** for illustrated rigging instructions and weight chart.

DOWNFLOW CONVERSION

NOTE: In downflow applications with roof curbs or jack stands, the center rail under the unit must be removed. The center rail is attached to the base rail with screws.

These units are adaptable to downflow use. To convert to downflow use, follow these steps:

1. Remove the blockoff plates found in the return air compartment and the supply air compartment.

NOTE: Blockoff plate in the supply air compartment only contains one screw. If reinstalling plate, back part of plate **MUST** fit into mating dimples on flange. To reinstall, slant plate into dimples, then put plate into position and fasten with screw.

2. Install the removed plates on the horizontal return and supply air openings.
3. Install roof curb on the building. Be sure to follow all directions included with curb and all applicable building codes in your installation.

Condensate Drain

The condensate drain outlet is a 3/4" (19.1mm) female PVC connection located at the bottom on the left hand side (see **Figure 2**).

The circulating blower creates a negative pressure on the condensate drain line that can prevent the condensate from draining properly. To combat this negative pressure, a field

supplied condensate trap that will allow a standing column of water of at least 2" (50.8mm) **MUST** be installed. Top of outlet from trap **MUST** be at least 1" (25.4mm) below top of outlet from unit. **Install the trap as near to the unit as possible for proper drainage.**

A 3/4" (19.1mm) drain line **MUST** be installed if required by local codes or if location of unit requires it. Run the drain line to an open drain or other suitable disposal point.

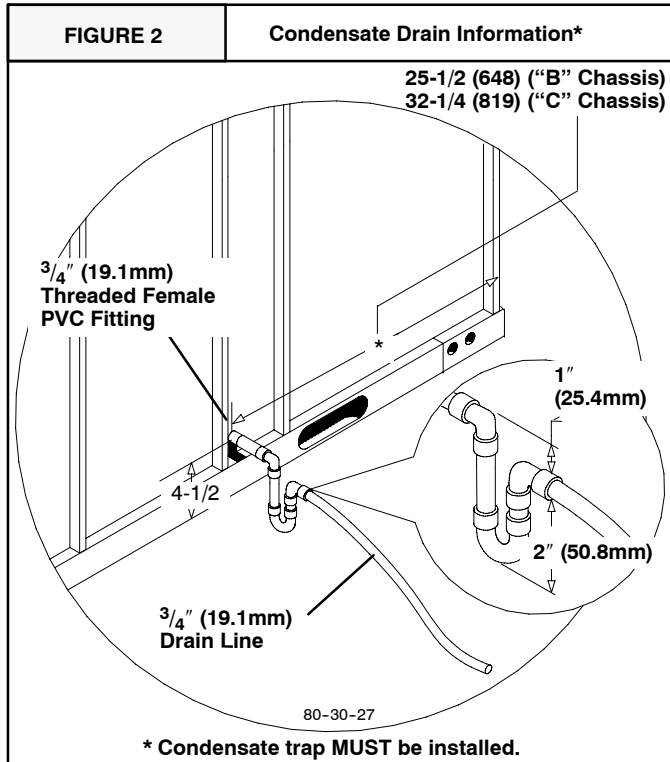

4. ELECTRICAL WIRING

⚠ WARNING
<p>ELECTRICAL SHOCK HAZARD.</p> <p>Failure to follow this warning could result in personal injury, death, and/or property damage.</p> <p>The unit cabinet must have an uninterrupted, unbroken electrical ground to minimize the possibility of serious injury if an electrical fault should occur. This ground may consist of an electrical wire connected to the unit ground lug in the control compartment, or conduit approved for electrical ground when installed in accordance with National Electric Code (NEC) NFPA 70, National Fuel Gas Code NFPA 54-2005/ANSI Z223.1-2005 and local electrical codes. In Canada, follow Canadian Electrical Code CSA (Canadian Standards Association) C22.1 and local electrical codes.</p>

⚠ CAUTION
<p>REDUCED EQUIPMENT LIFE HAZARD</p> <p>Failure to follow these precautions could result in damage to the unit being installed.</p> <ol style="list-style-type: none"> 1) Make all electrical connections in accordance with National Electric code (NEC) NFPA 70 and local electrical codes governing such wiring. In Canada, all electrical connections must be in accordance with CSA standard C22.1, Canadian Electrical Code Part 1, and applicable local codes. Refer to unit wiring diagram. 2) Use only copper conductor for connections between field-supplied electrical disconnect switch and unit. DO NOT USE ALUMINUM WIRE. 3) Be sure that high-voltage power to unit is within operating voltage range indicated on unit rating plate. 4) Do not damage internal components when drilling through any panel to mount electrical hardware, conduit, etc. Consult local power company for correction of improper voltage and/or phase imbalance.

Disconnect Switch

The unit must have separate electrical service with a field-supplied, waterproof, disconnect switch mounted at, or within sight from, the unit. Refer to the unit rating plate for maximum fuse/circuit breaker size and minimum circuit amps (ampacity) for wire sizing.

Ground Connections

Do **NOT** complete line voltage connections until unit is permanently grounded. All line voltage connections and the ground connection **MUST** be made with copper wire.

A ground lug is installed in the control box area for the ground connection. Use a copper conductor of the appropriate size from the unit to a grounded connection in the electrical service panel or a properly driven and electrically grounded ground rod. See warning above.

Line Voltage Wiring - (Wiring Diagrams page 13)

Connections for line voltage are made in the unit control box area. Refer to wiring diagram located on the Access panel. For access, remove the control box access panel.

1. Run the high voltage (L1, L2) and ground leads into the control box.
2. Connect ground lead to chassis ground connection.
3. Connect L1 to quick connect terminal 11 of the compressor contactor.
4. Connect L2 to quick connect terminal 23 of the compressor contactor.

Thermostat / Low Voltage Wiring

Location of the thermostat has an important effect on home comfort. FOLLOW THE THERMOSTAT INSTRUCTION MANUAL FOR CORRECT LOCATION, MOUNTING, AND WIRING.

A two stage thermostat is required for proper operation. Thermostat should have the following terminals: R, G,

W/W1, Y1, Y/Y2. The unit has the capability to run a 'dehumidification reduced airflow mode' if the thermostat has a humidity sensor and a DEHUM terminal which can be connected to the DH (Blk wire) in the low voltage splice box. The unit has color coded wires for easy connections. Using wire nuts, follow **FIGURE 3** for proper connections.

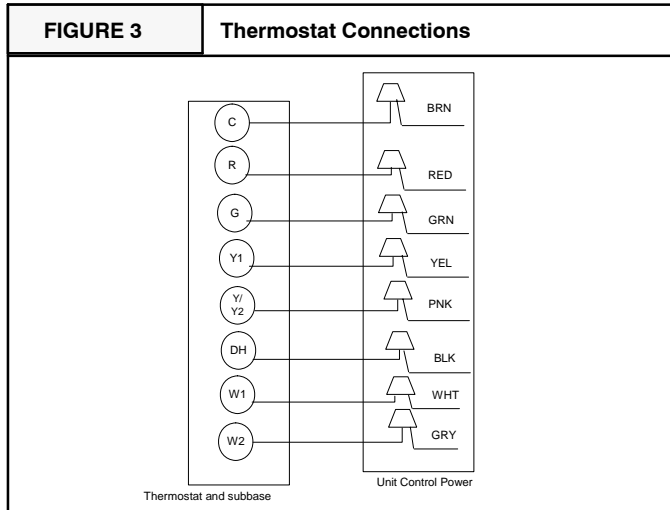

THERMOSTAT HEAT ANTICIPATOR

Some thermostats have an adjustable heat anticipator. The heat anticipator prevents temperature overshoot in heating mode. If the heat doesn't turn off until the set point temperature on the thermostat is exceeded, then the anticipator setting is too low. If the heat turns off before the thermostat reaches the set point temperature on the thermostat, then the anticipator setting is too high. Follow the thermostat instruction manual for proper adjustment of the heat anticipator.

Final Electrical Check

Make a final wiring check to be sure system is correctly wired. Inspect field installed wiring and the routing to ensure that rubbing or chafing due to vibration will not occur.

NOTE: Wiring **MUST** be installed so it is protected from possible mechanical damage.

5. DUCTWORK

Ductwork Sizing

The maximum recommended velocity in trunk ducts is 1000 feet per minute. The maximum recommended velocity in branch ducts is 800 feet per minute.

Ductwork sizing affects the discharge temperature, airflow velocity, and efficiency of the system. Be sure to properly size ductwork to the capacity of the unit and to the airflow requirements of the conditioned space. Failure to properly size ductwork can result in inadequate airflow and poor efficiency. Undersized ductwork may result in tripped limit controls and premature failure of compressors, motors and other components.

Ductwork Insulation

Ductwork installed outdoors must have a minimum 2" thick fiberglass "wrap" insulation and a weatherproof vapor barrier installed around it. The insulation and vapor barrier must be protected against potential damage. Caulking, flashing, and other means of providing a permanent weather seal must be used.

Ductwork Connections

The use of flexible, non-combustible connectors between main trunk ducts and supply and return air plenums is permitted. If flexible connectors are used, they should be protected from potential mechanical damage such as punctures and tears.

NOTE: When connecting the supply and return plenums to the unit, make sure that the plenums are sealed against the side casing of the unit and do not interfere with removal of the top of the unit.

FILTERS

All return air **MUST** pass through a filter before entering the unit. An electronic air cleaner, optional filter racks, or other accessible filter arrangement must be installed in the return air ductwork. Minimum recommended filter sizes are listed in **FIGURE 4** and are based on maximum face velocities of 300 ft/min for disposable filters and 600 ft/min for washable (high velocity) filters. See **FIGURE 4** for filter sizes.

⚠ CAUTION

REDUCED EQUIPMENT LIFE HAZARD

Failure to follow this caution may result in improper unit operation.

Do not operate the unit without a filter.

FIGURE 4		Filter Sizes		
Model	Disposable Filters		Washable Filters	
	Nominal Size Qty x wx d (in.)	Minimum Area sq. in.	Nominal Size Qty x wx d (in.)	Minimum Area sq. in.
PAX424	1 x 20 x 20	384	1 x 10 x 20	192
PAX430	1 x 20 x 24	480	1 x 12 x 20	240
PAX436	2 x 15 x 20	576	1 x 15 x 20	288
PAX442	2 x 18 x 20	672	1 x 18 x 20	336
PAX448	2 x 20 x 20	768	1 x 20 x 20	384
PAX460	2 x 20 x 24	960	1 x 20 x 24	480

6. AIRFLOW ADJUSTMENT

FIGURE 5		Airflow															
MODEL	COOLING												ELECTRIC HEAT				
	1st Stage						2nd Stage						5 kW	7.5kW	10kW	15 kW	20kW
	Rated SCFM			Dehum mode SCFM			Rated SCFM			Dehum mode SCFM							
	Low	Nominal	High	Low	Nominal	High	Low	Nominal	High	Low	Nominal	High					
024	504	560	616	403	448	493	720	800	880	576	640	704	850	850	850	-	-
030	585	650	715	468	520	572	788	875	963	630	700	770	850	850	850	1150	-
036	765	850	935	612	680	748	1080	1200	1320	864	960	1056	850	850	850	1150	-
042	878	975	1073	702	780	858	1260	1400	1540	1008	1120	1232	850	850	850	1150	1550
048	990	1100	1210	792	880	968	1440	1600	1760	1152	1280	1408	850	850	850	1150	1550
060	1170	1300	1430	936	1040	1144	1575	1750	1925	1260	1400	1540	850	850	850	1150	1550

CIRCULATING AIR BLOWER SPEEDS

The ID motor in this unit is capable of delivering constant airflow over a wide static range up to 0.7"WC. The blower airflow settings are given in **figure 5**. The ID motor speed tap board can be used to achieve the settings shown in figure 5. Based on the electric heater accessory, the correct heater size can be selected on the tap board so that the corresponding airflow is delivered by the motor. The airflow settings listed in the table are selectable by choosing the black tap wire setting of low, nominal and high. The first and second stage are actuated by compressor's mode of operation. Moreover, if a thermostat with a humidity sensor is available, dehumidification demand will actuate the dehumidification mode airflow listed in the table.

The ID motor is designed to provide various fan on / off delay options, selected by the white tap wire.

7. START-UP PROCEDURES

CHECK BEFORE STARTING

1. Check to see that the blower tap select board has the correct cooling and electric heat settings.
2. Check to see that clean, properly sized air filters are installed.
3. Replace all service access panels.

Check the unit's operation as outlined in the following instructions. If any unusual sparking, odors or unusual noises are encountered, shut off electric power immediately. Recheck for wiring errors, or obstructions in or near blower motors.

1. Set thermostat Heat-Cool selector to **OFF**.
2. Set thermostat fan switch to **AUTO**.
3. Turn electric power **ON**. Nothing should start running.
4. Set thermostat fan switch to **ON**.
5. Indoor fan should come on after field selectable **ON** delay.

6. Reset thermostat fan switch to **AUTO**.

COOLING

1. Turn electric power **OFF**
2. Set thermostat Heat-Cool select to **COOL**.
3. Adjust thermostat setting to below room temperature.
4. Turn power **ON**, for approximately one minute, then **OFF**. During power application check the following:
 - a. Contactor - Contacts Closing
 - b. Compressor - **ON**
 - c. Condenser fan motor - **ON**
 - d. Circulating Air Blower - **ON** 0 second delay
5. Turn power **OFF**, check the following:
 - a. Contactor contacts opening.
 - b. Compressor - **OFF**
 - c. Condenser fan motor - **OFF**
 - d. Circulating blower - **OFF** after the field selectable **OFF** delay for all models.

8. OPERATION

⚠ WARNING

ELECTRICAL SHOCK HAZARD.

Failure to follow this warning could result in personal injury, death and/or property damage.

Turn off electric power supply at disconnect switch or service panel before removing any access or service panel from unit.

TROUBLE SHOOTING

Models are factory equipped with the Comfort Alert™ Diagnostics device (refer to **Figure 6**) in the control box. Comfort Alert™ Diagnostics device provides compressor staging from low to high and high to low capacity. Comfort Alert™ Diagnostics device provides around-the-clock monitoring for common electrical problems, compressor defects, and broad system faults.

If trouble is detected, an alert code is displayed with a flashing LED indicator. Alert codes are listed in **Figure 6**. The device is factory wired and requires no modification. Low voltage lead wires are provided in the control box for connection to thermostat wires (use wire nuts). The Comfort Alert™ Diagnostics device must be powered to

properly stage compressor to high capacity. Energizing the Y (Y1) terminal operates the compressor in low stage. Both the Y (Y1) and Y2 terminals must be energized for high stage operation. The Comfort Alert™ Diagnostics device operates by monitoring the compressor power leads and the thermostat demand signals Y (Y1) and Y2 terminals. It draws constant 24 VAC power at the R and C terminals. When the compressor is operating in low stage (Y or Y1), the 24v DC compressor solenoid coil is de-energized. When the compressor is operating in high

stage (Y or Y1 and Y2), the 24v DC solenoid coil is energized.

NOTE: There is a 5 sec delay from when Y2 gets energized to when the solenoid is energized.

The Comfort Alert™ Diagnostics is a passive device. This device will not shut down unit if it senses a fault.

The 24vDC plug that is connected to the compressor does NOT have an internal rectifier. DO NOT INSTALL A PLUG WITH INTERNAL RECTIFIER.

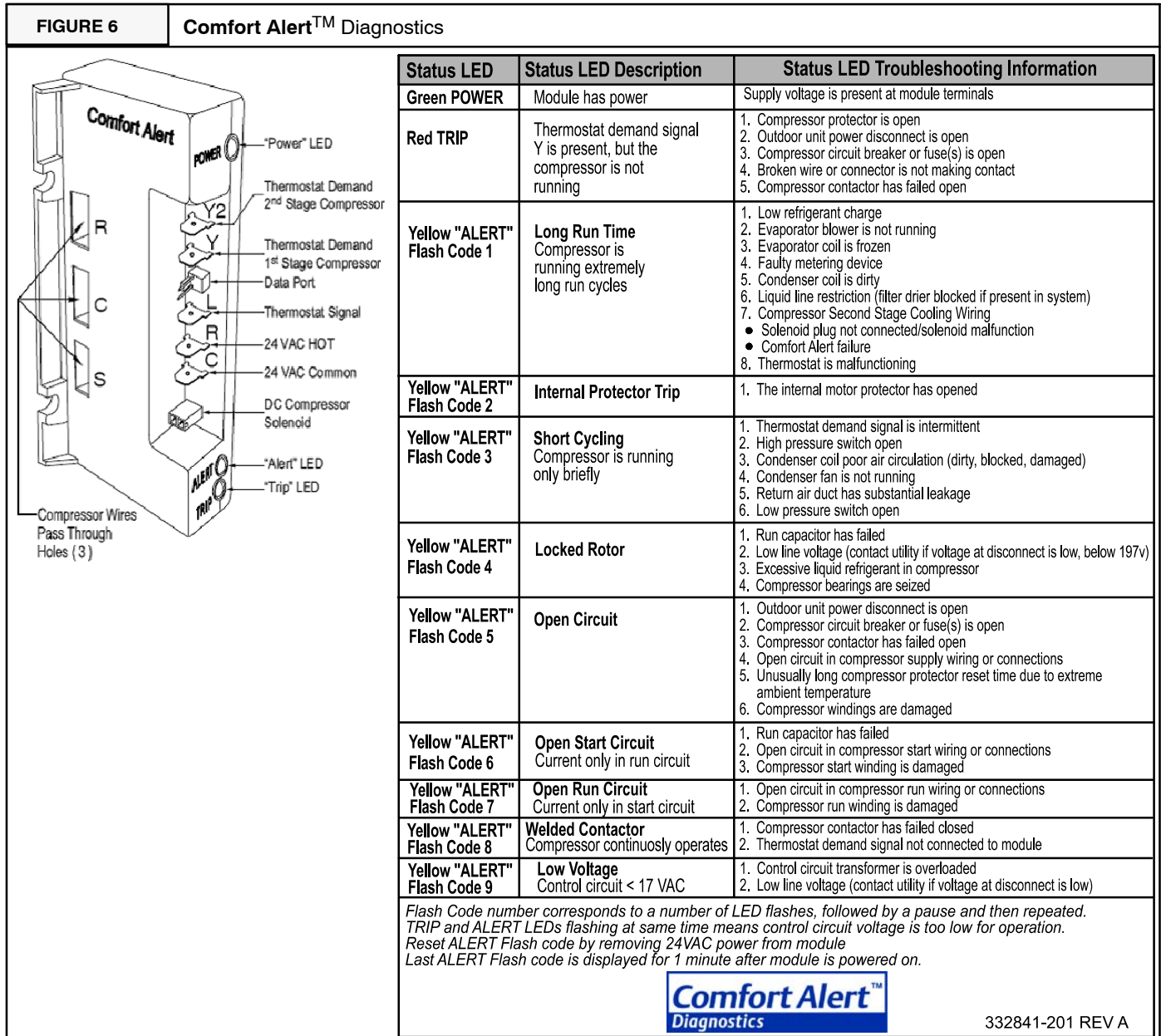

Cooling Operation (All Models):

These units use a two stage thermostat. With a first stage call for cooling (Y1), the compressor energizes in low stage along with the outdoor fan. The Indoor motor starts in low stage as well. If the low stage cooling does not meet the demand, the high stage cooling demand (Y/Y2) energizes the second stage of compressor along with the high stage of ID motor. When the cooling demand is met, the compressor and the OD fan motor shut off. The ID motor will run for the programmed off time delay, if selected before shutting

down.

Heating Operation (All Models):

With a call for heating (W1), the auxiliary electric heater is energized along with the blower motor. The blower will deliver an airflow selected on the tap selected board per the electric heater size. If the demand is not, W2 energizes the second stage of electric heater. When the demand is met, the electric heater de-energizes along with the Indoor blower motor.

Continuous Fan:

Is field selectable for HI (100% of Y2), MED (70 – 75% of Y2) and LO (40% of Y2). HI, MED., and LO are dependant on what airflow has been field selected for HIGH (Y2) stage cooling.

SYSTEM CHARGING: Use the subcooling chart, **Figure 7**, to charge the unit in cooling mode. Follow the instructions in the subcooling chart.

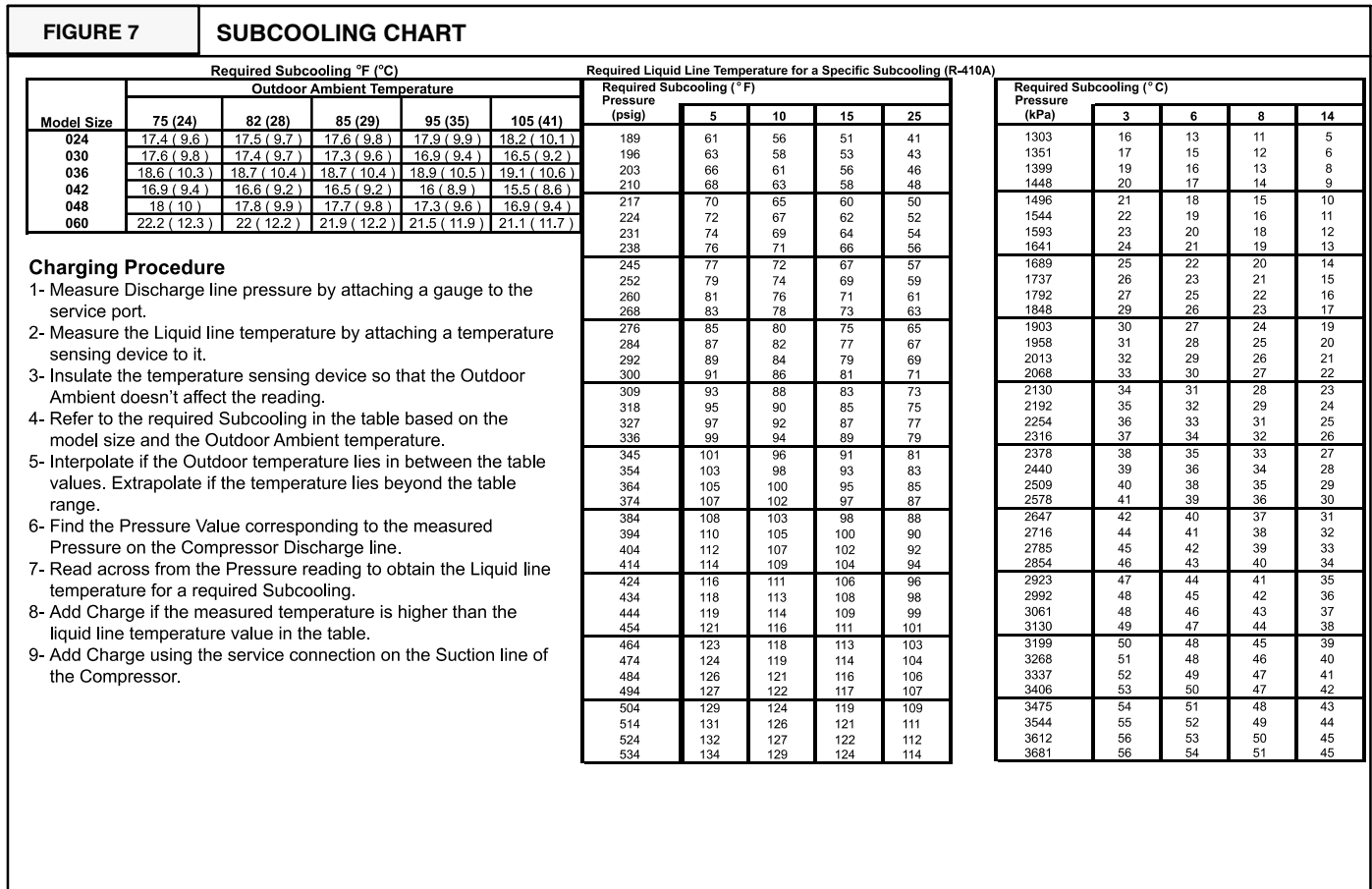

9. MAINTENANCE

MONTHLY MAINTENANCE AND INSPECTION CHECKS

Air Filters

⚠ CAUTION

REDUCED EQUIPMENT LIFE HAZARD

Failure to follow this cautions may result in damage to the unit being installed.

Do not operate the unit without a filter.

Inspect filters at least monthly and replace or clean as required. Washable filters may be cleaned by soaking in mild detergent and rinsing with cold water. Replace filters with the arrows on the side pointing in the direction of air flow. Dirty filters are the most common cause of inadequate heating or cooling performance, and of compressor failures.

COOLING SEASON CHECKS (MONTHLY)

Condenser Coil

Keep the condenser inlet and outlet area clean and free of leaves, grass clippings or other debris. Grass should be

kept short in front of the condenser inlet. Shrubbery **MUST** be trimmed back so it is no closer than 30 inches to unit.

Condensate Drain

Check for condensate drainage. Clean as required.

ANNUAL MAINTENANCE AND INSPECTION

⚠ WARNING

ELECTRICAL SHOCK HAZARD.

Failure to follow this warning could result in personal injury, death and/or property damage.

Turn off electric power supply at disconnect switch or service panel before removing any access or service panel from unit.

The annual inspection should include cleaning as required to ensure efficient operation of the unit. To simplify access, remove all access panels and the top from the unit if possible .

Condenser Fan Motor

Note: The condenser fan motor is permanently lubricated. No further lubrication is required. Do not attempt to lubricate the condenser fan motor.

Clean the surrounding area and the condenser and evaporator coils. Use caution to avoid damage to coil fins.

BLOWER MOTOR ACCESS

1. Remove the blower access panel
2. Remove the three screws securing the blower motor housing. If unit has a support bracket, remove the two screws securing the bracket.
3. Remove the two red wires attached to the limit switch and remove the limit switch.

Motor removal and replacement

This method is required to replace or repair blower wheel, blower housing, or any unreachable components behind blower assembly.

1. Remove all screws around rim of unit top, (except screws which are inaccessible because of proximity to structure).
2. Raise unit top at corner of unit closest to blower at least 2" and place a sturdy brace at least 2" thick between top and unit corner. A 2X4 piece of wood is ideal for this.
3. Disconnect all wires from housing and slide housing out of unit. Reverse this process to reinstall.

Circulating Air Blower

Visually inspect the blower wheel for accumulations of dirt or lint. Clean the compartment and the blower wheel. If accumulation is excessive on blower wheel, or does not easily remove, it will be necessary to remove the blower assembly.

Note: The blower motor is permanently lubricated. No further lubrication is required. Do not attempt to lubricate the blower motor.

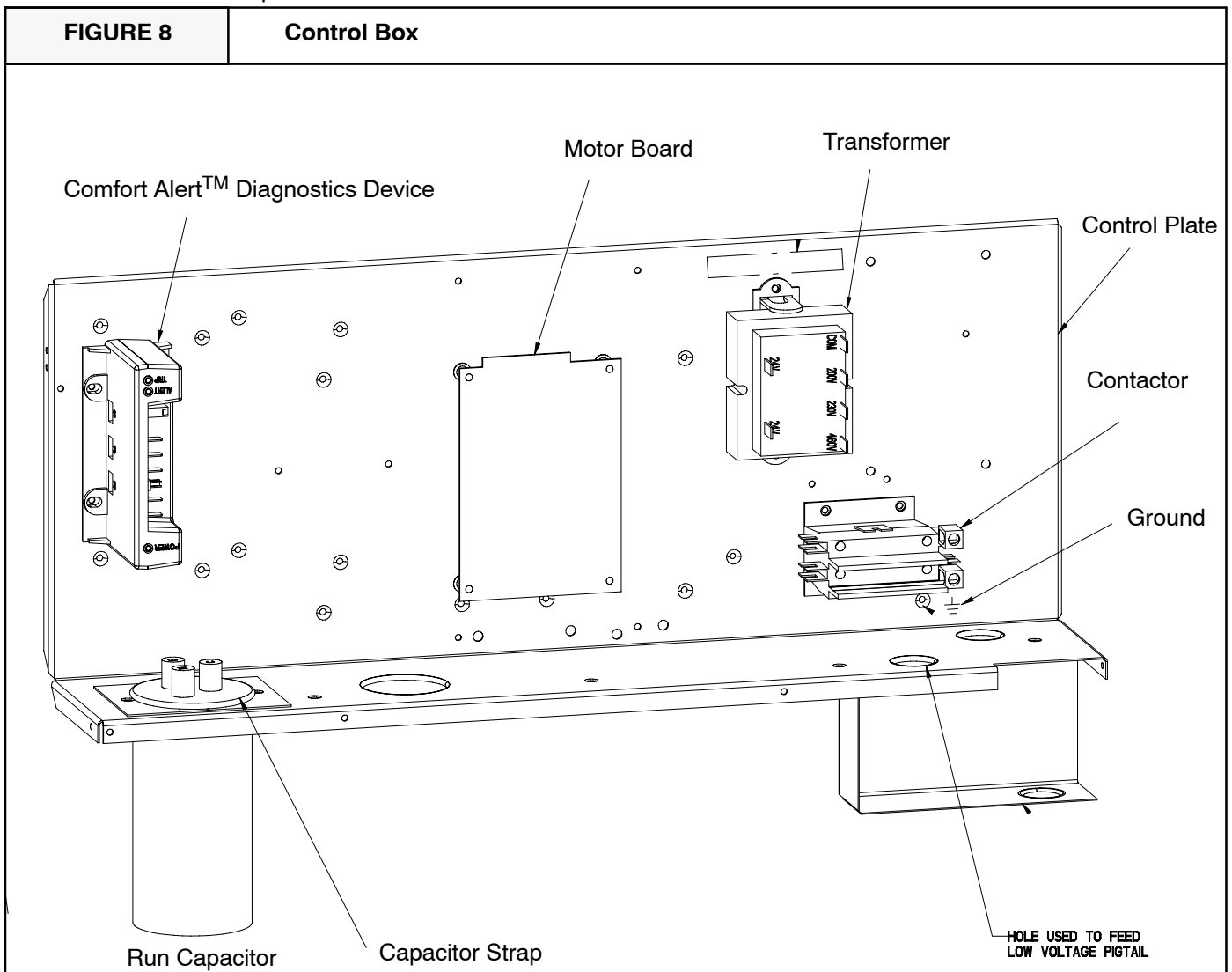

FIGURE 9

Rigging Instructions

50CY501872

RIGGING INSTRUCTIONS

FAILURE TO FOLLOW THESE INSTRUCTIONS CAN RESULT IN PROPERTY DAMAGE, BODILY INJURY OR DEATH.

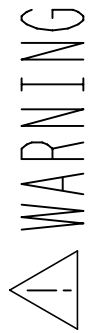

- ALL PANELS MUST BE IN PLACE WHEN RIGGING AND LIFTING.
- HOOK RIGGING SHACKLES THROUGH HOLES IN BASE RAIL, AS SHOWN IN DETAIL-A.
- USE SPREADER BARS, WHEN RIGGING, TO PREVENT UNIT DAMAGE.
- BE SURE RIGGING AND SHACKLES ARE SUFFICIENT TO HANDLE WEIGHT LISTED BELOW.

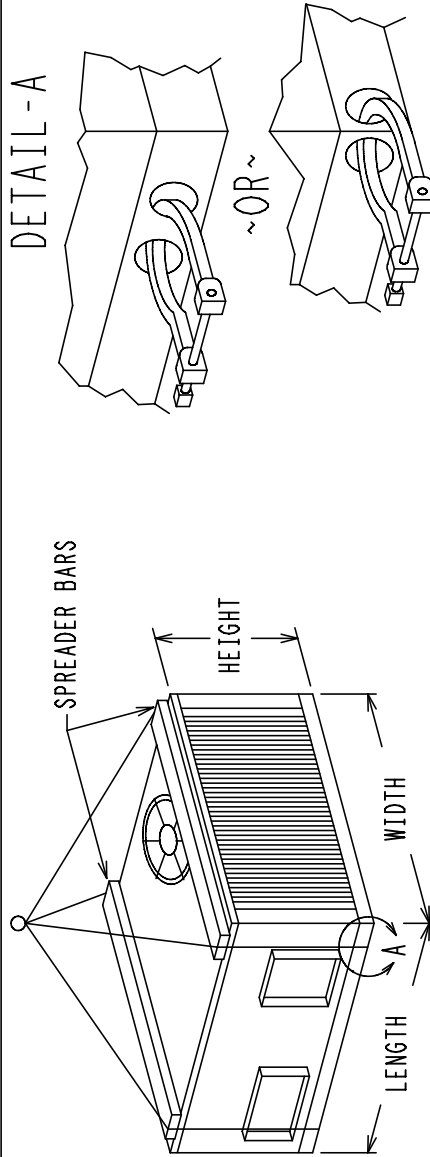

CABINET	MAX. LENGTH		MAX. WIDTH		MAX. HEIGHT		MAX. WEIGHT	
	IN	MM	IN	MM	IN	MM	LB	KG
SMALL	52.00	1219	48.00	1219	38.00	965	500	227
LARGE	73.00	1854	48.00	1219	44.00	1118	680	308

10. Wiring Diagrams

2 to 5 Ton Wiring Diagram

SCHEMATIC
208/230-1-60

