

ASHRAE 90.1 COMPLIANT PACKAGE GAS HEATING/ELECTRIC COOLING, VERTICAL SUPPLY/RETURN AIR CONFIGURATION ONLY R-410A SINGLE PACKAGE ROOFTOP 17.5 – 27.5 TONS

BUILT TO LAST, EASY TO INSTALL AND SERVICE

- One-piece, standard efficiency gas heating and electric cooling with a low profile, prewired, tested, and charged at the factory
- Dedicated vertical air flow duct configuration models.
- Full perimeter base rail with built-in rigging adapters and fork truck slots
- Pre-painted exterior panels and primer-coated interior panels tested to 500 hours salt spray protection
- Fully insulated cabinet
- Two-stage cooling with independent circuits and control on all models
- Redundant gas valve for two stage gas heating capacity control
- Exclusive IGC solid-state control for on-board diagnostics with LED error code designation, burner control logic and energy saving indoor fan motor delay
- High efficiency, gas heat with induced draft flue exhaust design
- Scroll compressors with internal line-break connections on all models
- All units have high and low pressure switches
- Two inch disposable fiberglass type return air filters in dedicated rack
- Refrigerant circuits contain a liquid line filter drier to trap dirt and moisture
- Round tube plate fin evaporator and condenser coil design
- Exclusive non-corrosive composite condensate pan in accordance with ASHRAE 62 Standard, sloping design; end drain
- Belt drive evaporator-fan motor and pulley combinations available to meet most applications
- Access panels with easy grip handles provide quick and easy access to the blower and blower motor, control box, and compressors.
- "No-strip" screw system has superior holding power and guides screws into position while preventing the screw from stripping the unit's metal.
- Newly designed terminal board facilitates simple safety circuit troubleshooting and simplified control box arrangement
- Standard outdoor temperature cooling operation range up to 115°F (46°C) and down to 30°F (-1°C)
- Fixed orifice metering devices on all models to precisely control refrigerant flow
- Large, laminated control wiring and power wiring drawings are affixed to unit to make troubleshooting easy
- Single point gas and electrical connections

WARRANTY

- 15 Year limited warranty on optional stainless steel heat exchanger.
- 10 Year limited warranty on aluminized steel heat exchanger
- 5 Year compressor limited warranty
- 1 Year parts limited warranty



17.5 Ton



20 & 25 Ton



Use of the AHRI Certified TM Mark indicates a manufacturer's participation in the program. For verification of certification for individual products, go to www.ahridirectory.org.



UNIT PERFORMANCE DATA – Two Stage Cooling								
UNIT	Dedicated Airflow	Nominal Tons	COOLING		GAS HEATING		Unit Dimensions H x W x L	Shipping Weight lb. [kg]
			Net Cap. (Btuh)	EER	Input Cap. (Btuh) Stage 2	Thermal Efficiency (%)		
RGS210*^AA0AAA	Vertical	17.5	208,000	10.8	220,000 – 400,000	81.0	49-3/8" x 86-5/8" x 127-7/8"	1948 [884]
RGS240*^AA0AAA	Vertical	20	242,000	9.8	220,000 – 400,000	81.0	49-3/8" x 86-5/8" x 141-1/2"	2098 [952]
RGS300*^AA0AAA	Vertical	25	280,000	9.8	220,000 – 400,000	81.0	57-3/8" x 86-5/8" x 141-1/2"	2234 [1013]
RGS336*^AA0AAA	Vertical	27.5	330,000	10.2	220,000 – 400,000	81.0	57-3/8" x 86-5/8" x 157-3/4"	2668 [1210]

* Indicates Unit voltage: H = 208/230-3-60, L = 460-3-60, S = 575-3-60

^ See model nomenclature listing for gas heating options.

NOTE: BASE MODEL NUMBERS LISTED. SEE MODEL NOMENCLATURE LISTING FOR ADDITIONAL OPTIONS

TABLE OF CONTENTS

	PAGE		PAGE
MODEL NUMBER NOMENCLATURE	3	COOLING TABLES	27
FACTORY OPTIONS AND/OR ACCESSORIES	4	STATIC PRESSURE ADDERS	34
AHRI COOLING RATING TABLE	9	FAN PERFORMANCE	34
SOUND PERFORMANCE TABLE	9	OUTDOOR AIR INTAKE & EXHAUST PERF	38
HEAT RATING TABLES	10	ELECTRICAL INFO	39
PHYSICAL DATA	11	SEQUENCE OF OPERATION	51
CURBS & WEIGHTS DIMENSIONS	15	GUIDE SPECIFICATIONS	52
APPLICATION DATA	25		

MODEL NOMENCLATURE

MODEL SERIES	R	G	S	2	1	0	H	D	A	B	0	A	A	A
Position Number	1	2	3	4	5	6	7	8	9	10	11	12	13	14
R = Rooftop														
A = Air Conditioning (Cooling Only) G = Gas/Electric Type														
S = Standard ASHRAE 90.1-2010 Efficiency Efficiency														
210 = 210,000 = 17.5 Tons Dedicated Vertical SA/RA (SA = Supply Air, RA = Return Air) 240 = 240,000 = 20 Tons Dedicated Vertical SA/RA 300 = 300,000 = 25 Tons Dedicated Vertical SA/RA 336 = 330,000 = 27.5 Tons Dedicated Vertical SA/RA Nominal Cooling Capacity														
H = 208/230-3-60 L = 460-3-60 S = 575-3-60 Voltage														
D = Low Heat E = Medium Heat F = High Heat S = Low Heat, Stainless Steel Heat Exchanger R = Medium Heat, Stainless Steel Heat Exchanger T = High Heat, Stainless Steel Heat Exchanger Heating Capacity														
A = Standard Static Option (all sizes, with 1-speed and 2-speed indoor fan motor) B = High Static High Efficiency Option (all sizes, with 2-speed indoor fan motor) C = Medium Static Option (17.5 ton, with 1-speed indoor fan motor, all sizes with 2-speed indoor fan motor) E = High Static High Efficiency Option (all sizes, with 1-speed indoor fan motor) F = Medium Static High Efficiency Option (20, 25, 27.5 ton, with 1-speed indoor fan motor) G = High Static Motor with Hot Gas Re-heat (17.5, 20, and 25, with 1-speed indoor fan motor) H = High Static Motor with Hot Gas Re-heat (17.5, 20, and 25, with 2-speed indoor fan motor) Motor Option														
A = None B = Economizer w/Bara-relief, OA Temp sensor E = Economizer w/Bara-relief + CO ₂ sensor, OA Temp sensor H = Economizer w/Bara-relief, Enthalpy sensor L = Economizer w/Bara-relief + CO ₂ sensor, Enthalpy sensor U = Ultra Low Leak Temp Economizer w/Bara-relief (2-speed indoor fan motor only) W = Ultra Low Leak Temp Enthalpy Economizer w/Bara-relief (2-speed indoor fan motor only) P = 2-Position damper Outdoor Air Options / Control														
OA = No Options 4B = Non-fused Disconnect AA = Hinged Access Panels AT = Non-powered 115v Convenience Outlet. BR = Supply Air Smoke Detector Other Factory Installed Options¹														
A = Alum / Cu Cond & Alum / Cu Evap B = Pre coated Alum / Cu Cond & Alum / Cu Evap C = E-coated Alum / Cu Cond & Alum / Cu Evap D = E-coated Alum / E-coated Cu Cond & Alum / Cu Evap E = Cu / Cu Cond & Alum / Cu Evap F = Cu / Cu Cond & Cu / Cu Evap Coil Factory Installed Options														
A = Standard Motor T = 2 Speed Indoor Fan VFD Controller (For 2-stage units only) Motor Type Option														

¹ A combination of FIOP's are available.

Table 1 – FACTORY INSTALLED OPTIONS AND FIELD INSTALLED ACCESSORIES

CATEGORY	ITEM	FACTORY INSTALLED OPTION	FIELD INSTALLED ACCESSORY
Cabinet	Dedicated Vertical Air Flow Duct Configuration	X	
Coil Options	Cu/Cu Coils	X	
	Pre-Coat (outdoor) Coils	X	
	E-coated (outdoor & indoor) coils	X	
Condenser Protection	Condenser coil hail guard (louvered design)		X
Humidity Control	Hot Gas Reheat	X	
Controls	Smoke detector (supply air)	X	X
	Time Guard II compressor delay control circuit		X
	Phase Monitor		X
Economizers & Outdoor Air Dampers	Economizer	X	X
	Low Leak Economizer X for 2-speed Indoor Fan VFD Controller (For 2-stage units only) Vertical supply/return.	X	X
	Motorized 2 position outdoor-air damper	X	X
	Manual outdoor-air damper (25%)		X
	Barometric relief ¹	X	X
	Power exhaust-centrifugal blower		X
Economizer Sensors & IAQ Devices	Single dry bulb temperature sensors ²	X	X
	Single enthalpy sensors ²	X	X
	Differential enthalpy sensors ²		X
	Duct mounted CO ₂ sensor ²		X
	4-in Filter Track Assembly		X
Gas Heat	Propane conversion kit		X
	Stainless steel heat exchanger	X	
	High altitude conversion kit		X
	Flue Discharge Deflector		X
Indoor Motor & Drive	Multiple motor and drive packages	X	
	2-Speed VFD drive motor system	X	
	VFD Remote keypad kit		X
Low Ambient Control	Winter start kit ³		X
	Motormaster head pressure controller ³		X
Power Options	Convenience outlet (unpowered)	X	
	Non-fused disconnect ⁴	X	
Roof Curbs	Roof curb 14-in (356mm)		X
	Roof curb 24-in (610mm)		X

NOTES:

1. Included with economizer.
2. Sensors used to optimize economizer performance.
3. See application data for assistance.
4. Non-fused disconnect switch cannot be used when MOCP electrical rating exceeds 70 amps at 460/575 volt and 150 amps at 208/230 volt.

FACTORY OPTIONS AND/OR ACCESSORIES

2-Speed VFD Drive Motor

The 2-speed VFD drive motor system saves energy and installation time by utilizing a Variable Frequency Drive (VFD) to automatically adjust the indoor fan motor speed in sequence with the units cooling operation. Per ASHRAE 90.1 2010 standard section 6.4.3.10.b, during the first stage of cooling operation the VFD will adjust the fan motor to provide 2/3rd of the total cfm established for the unit. When a call for the second stage of cooling is required, the VFD will allow the total cfm for the unit established (100%). During the heating mode the VFD will allow total design cfm (100%) operation and during the ventilation mode the VFD will allow operation to 2/3rd of total cfm.

Compared to single speed indoor fan motor systems, 2 speed system can save substantial energy, 25%+, versus single speed indoor fan motor systems.

The VFD used in the system has soft start capabilities to slowly ramp up the speeds, thus eliminating any high inrush air volume during initial start-up. It also has internal over-current protection for the fan motor and a field installed display kit that allows adjustment and in depth diagnostics of the VFD.

This system is available on models with 2-stage cooling operation with electro-mechanical controls. Both space sensor and conventional thermostats/controls can be used to provide accurate control in any application.

The system is very flexible for initial fan performance set up and adjustment. The standard factory shipped VFD is pre-programmed to automatically stage the fan speed between the first and second stage of cooling. The unit fan performance static pressure and cfm can be easily adjusted using the traditional means of pulley adjustments. The other means to adjust the unit static and cfm performance is to utilize the field installed Display Kit and adjust the frequency and voltage in the VFD to performance requirements. In either case, once set up, the VFD will automatically adjust the speed between the cooling stage operations.

Economizer (dry-bulb or enthalpy)

Economizers save money. They bring in fresh, outside air for ventilation; and provide cool, outside air to cool your building. This is the preferred method of low-ambient cooling. When coupled to CO₂ sensors, economizers can provide even more savings by coupling the ventilation air to only that amount required.

Economizers are available, installed and tested by the factory, with either enthalpy or dry-bulb temperature inputs. Additional sensors are available as accessories to optimize the economizers.

Economizers include gravity controlled, barometric relief equalizes building pressure and ambient air pressures. This can be a cost effective solution to prevent building pressurization. If further control of exhaust air is required, a dual centrifugal fan power exhaust system is also available.

CO₂ Sensor

Improves productivity and saves money by working with the economizer to intake only the correct amount of outside air for ventilation. As occupants fill your building, the CO₂ sensor detects their presence through increasing CO₂ levels, and opens the economizer appropriately.

When the occupants leave, the CO₂ levels decrease, and the sensor appropriately closes the economizer. This intelligent control of the ventilation air, called Demand Control Ventilation (DCV) reduces the overall load on the rooftop, saving money.

Smoke Detector

Smoke detectors make your application safer and your job easier. Smoke detectors immediately shut down the rooftop unit when smoke is detected. It is available for supply air.

Louvered Hail Guards (accessory only)

Sleek, louvered panels protect the condenser coil from hail damage, foreign objects, and incidental contact.

Convenience Outlet (un-powered)

Reduce service and/or installation costs by including a convenience outlet in your specification. The convenience outlet provides, 15 amp, 115v GFCI receptacle with "Wet in Use" cover. This option is to be powered from a separate 115/120v power source.

Non-Fused Disconnect

This OSHA-compliant, factory-installed, safety switch allows a service technician to locally secure power to the rooftop capable of providing protection to a MOCP maximum of 200A.

Power Exhaust with Barometric Relief

Superior internal building pressure control. This field-installed accessory may eliminate the need for costly, external pressure control fans.

Time Guard II Control Circuit

This accessory protects your compressor by preventing short-cycling in the event of some other failure, prevents the compressor from restarting for 30 seconds after stopping.

Motorized 2-Position Damper

The new 2-position, motorized outdoor air damper admits up to 100% outside air. Using reliable, gear-driven technology, the 2-position damper opens to allow ventilation air and closes when the rooftop stops, stopping unwanted infiltration.

Manual OA Damper (accessory only)

Manual outdoor air dampers are an economical way to bring in ventilation air. The dampers are available in 25% versions.

Motormaster Head Pressure Controller

The Motormaster motor controller is a low ambient, head pressure controller kit that is designed to maintain the unit's condenser head pressure during periods of low ambient cooling operation. This device should be used as an alternative to economizer free cooling not when economizer usage is either not appropriate or desired. The Motormaster will either cycle the outdoor-fan motors or operate them at reduced speed to maintain the unit operation, depending on the model. MotorMaster allows cooling operation down to -20°F (-29°C).

Winter Start Kit (accessory only)

The winter start kit extends the low ambient limit of your rooftop to 25°F (-4°C). The kit bypasses the low pressure switch, preventing nuisance tripping of the low pressure switch. Other low ambient precautions may still be prudent.

FACTORY OPTIONS AND/OR ACCESSORIES (CONT.)

Propane Heating (accessory only)

Convert your gas heat rooftop from standard natural gas operation to propane using this field-installed kit.

High Altitude Heating (accessory only)

High altitudes have less oxygen, which means heat exchangers need less fuel. The new gas orifices in this field-installed kit make the necessary adjustment for high altitude applications. They restore the optimal fuel to air mixture and maintain healthy combustion at altitudes above 2000 ft (610m). Kits may not be required in all areas.

Optional Stainless Steel Heat Exchanger

The stainless steel heat exchanger option provides the tubular heat exchanger be made out of a minimum 20 gauge type 409 stainless steel for applications where the mixed air to the heat exchanger is expected to drop below 45°F (7°C). Stainless steel may be specified on applications where the presence of airborne contaminants require its use or in area with very high outdoor humidity that may result in severe condensation in the heat exchanger during cooling operation.

Flue Discharge Deflector (accessory only)

The flue discharge deflector is a useful accessory when flue gas recirculation is a concern. By venting the flue discharge upwards, the deflector minimizes the chance for a neighboring unit to intake the flue exhaust.

High Static Motors and Drives

Some applications need larger horsepower motors, some need more airflow, and some need both. A wide selection of motors and pulleys (drives) are available, factory installed, to handle nearly any application.

Hot Gas Reheat System

Hot Gas Reheat is an all-inclusive factory installed option that can be ordered with RGS units.

This system expands the envelope of operation of rooftop products to provide unprecedented flexibility to meet year round comfort conditions.

The Hot Gas Reheat has the industry's only dual dehumidification mode setting. The Hot Gas Reheat System includes two new modes of operation.

RGS rooftop units coupled with the Hot Gas Reheat is capable of operating in normal design cooling mode, subcooling mode, and hot gas reheat mode. Normal design cooling mode is when the unit will operate under its normal sequence of operation by cycling compressors to maintain comfort conditions.

Subcooling mode will operate to satisfy part load type conditions when the space requires combined sensible and a higher proportion of latent load control. Hot Gas Reheat mode will operate when outdoor temperatures diminish and the need for latent capacity is required for sole humidity control. Hot Gas Reheat mode will provide neutral air for maximum dehumidification operation.

ACCESSORIES – RGS210–336

ECONOMIZERS^{1, 2}		
Model Number	Description	Use With Model Size
DNECOMZR052A00	Economizer IV, Vertical with solid state controller	210 – 240
DNECOMZR053A00	Economizer IV, Vertical with solid state controller	300 – 336
CRECOMZR074A00	Ultra Low Leak Vertical Economizer X with solid–state controller, gear–driven, fully modulating damper, spring return actuator, up to 100% barometric relief, supply and outdoor air sensors, and CO2 sensor compatible.	210 – 240
CRECOMZR075A00	Ultra Low Leak Vertical Economizer X with solid–state controller, gear–driven, fully modulating damper, spring return actuator, up to 100% barometric relief, supply and outdoor air sensors, and CO2 sensor compatible.	300 – 336

¹ Economizer X cannot be installed with Economizer IV, manual damper, or motorized damper.

² Can only be used on electrical mechanical units with 2–stage cooling and 2–speed fan control.

ECONOMIZER SENSORS		
Model Number	Description	Use With Model Size
DNTEMPSN002A00	Single (dry bulb) Control	Economizers IV
DNCBDIOX005A00	CO2 Sensor and aspirator box for use in return air stream.	Economizers IV & X
DNENTDIF004A00	Return Air Enthalpy Sensor	Economizers IV
AXB078ENT	Enthalpy Control	Economizers IV
CRTEMPSN005A00	Outdoor or return dry bulb temperature sensor used with Honeywell W7220 electro–mechanical control.	Economizer X
--HH--57AC-081	Enthalpy control for W7220 controller only. (One required for single enthalpy, two required for differential enthalpy)	Economizer X

NOTE: Supply air temperature sensor (SAT and low ambient lockout switch) provided with economizer IV or economizer X.

POWER EXHAUST		
Model Number	Description	Use With Model Size*
CRPWREXH068A00	Vertical, 208/230–3–60	ALL
CRPWREXH069A00	Vertical, 460–3–60	ALL
CRPWREXH070A00	Vertical, 575–3–60	ALL

*Power exhaust can be used with both Economizer IV and Economizer X. The power exhaust is controlled by the Economizer controller.

MANUAL OUTDOOR AIR DAMPERS		
Model Number	Description	Use With Model Size
CRMANDPR009A00	25% Open Manual Fresh Air Damper	210 – 240
CRMANDPR010A00	25% Open Manual Fresh Air Damper	300 – 336

MOTORIZED OUTDOOR AIR DAMPERS		
Model Number	Description	Use With Model Size
CRTWOPOS012A00	Motorized 2 position outdoor air damper	210 – 240
CRTWOPOS013A00	Motorized 2 position outdoor air damper	300 – 336

LOW AMBIENT CONTROLS		
Model Number	Description	Use With Model Size
CRLOWAMB041A00 ¹	Motormaster® I –20° Low Ambient Control 208/230–3–60	210–240–300–336
CRLOWAMB042A00 ¹	Motormaster® I –20° Low Ambient Control 460–3–60, 575–3–60	210–240–300–336
CRTRXKIT001A00	Motormaster® I –20° Transformer 575–3–60 Must be used in conjunction with Low Ambient Controller if used on 575–3–60 models.	210–240–300–336

¹ Also requires one DNWINSTR001A00 winter start kit per circuit.

ACCESSORIES – RGS210–336 (cont.)

FLAT ROOF CURBS		
Model Number	Description	Use With Model Size
CRRFCURB045A00	14" (356 mm) High Roof Curb. Ductwork attaches to the roof curb. Includes thru-the-bottom capability.	210
CRRFCURB047A00		240 – 300
CRRFCURB049A00		336
CRRFCURB046A00	24" (607 mm) High Roof Curb. Ductwork attaches to the roof curb. Includes thru-the-bottom capability.	210
CRRFCURB048A00		240 – 300
CRRFCURB050A00		336
CONTROL UPGRADE KITS		
Model Number	Description	Use With Model Size
CRDISKIT001A00	VFD Remote keypad kit for replacement VFD drive module.	ALL
NRTIMEGD001A00	Time Guard II	ALL
CRSDTEST001A00	Smoke detector remote Test/Reset/Alarm indicator kit	ALL
CRPHASE3001A02	Electronic Phase Monitor – All 208/230/460–3–60 models	ALL
CRPHASE3002A00	Electronic Phase Monitor – All 575–3–60 models	ALL
CRSTATUS005A00	Fan/filter Status Switch – Indicator light not included	ALL
CRSMKSEN002A00	Smoke Detector Control Module	ALL
CRSMKKIT002A00	Smoke Detector Control Module (Smoke Detector Sensor with sampling tube & exhaust tube)	ALL
DNWINSTR001A00	Winter Start Kit – Contains time delay relay for timed bypass of low pressure switch on startup	ALL
PROPANE GAS CONVERSION KITS		
Model Number	Description	Use With Model Size
CRLPKIT9001A00	Propane Conversion kit. for use between 0' to 2,000'	ALL
CRLPELEV005A00	Propane and Hi Altitude conversion kit. for use between 2001' to 10,000'	ALL
CRLPELEV006A00	Propane and Hi Altitude conversion kit. for use between 10,001' to 14,000'	ALL
NATURAL GAS HIGH ALTITUDE CONVERSION KITS		
Model Number	Description	Use With Model Size
CRNGELEV001A00	High Altitude Conversion kit. for use between 3,000' to 10,000'	ALL
CRNGELEV002A00	High Altitude Conversion kit. for use between 10,001' to 14,000'	ALL
HEATING UPGRADE KITS		
Model Number	Description	Use With Model Size
CRFLUEDS006A00	Flue Discharge Deflector	ALL
4" FILTER TRACK UPGRADE KIT		
Model Number	Description	Use With Model Size
CRFLTTRK001A00	4" Field Conversion Kit	ALL
LOUVERED HAIL GUARDS		
Model Number	Description	Use With Model Size
CRLVHLGD017A00	Louvered Condenser Coil Hail Guard	210
CRLVHLGD027A00	Louvered Condenser Coil Hail Guard	240
CRLVHLGD028A00	Louvered Condenser Coil Hail Guard	300
CRLVHLGD029A00	Louvered Condenser Coil Hail Guard	336

Table 2 – AHRI COOLING RATING TABLE

UNIT RGS	COOLING STAGES	NOM. CAPACITY (TONS)	NET COOLING CAPACITY (MBH)	TOTAL POWER (kW)	EER	IEER WITH SINGLE SPEED INDOOR FAN MOTOR	IEER WITH 2-SPEED INDOOR FAN MOTOR
210	2	17.5	208.0	19.3	10.8	11.7	12.7
240	2	20	242.0	24.7	9.8	10.6	11.7
300	2	25	280.0	28.6	9.8	10.4	11.5
336	2	27.5	330.0	32.4	10.2	10.4	11.5

LEGEND

- AHRI – Air-Conditioning & Refrigeration Institute
- ASHRAE – American Society of Heating, Refrigerating and Air Conditioning, Inc.
- EER – Energy Efficiency Ratio
- IEER – Integrated Energy Efficiency Ratio
- IPLV – Integrated Part Load Value

NOTES:

1. Rated and certified under AHRI Standard 340/360-04, as appropriate.
2. Ratings are based on:
Cooling Standard: 80°F (27°C) db, 67°F (19°C) wb indoor air temp and 95°F (35°C) db outdoor air temp.
IEER Standard: A measure that expresses cooling part-load EER efficiency for commercial unitary air conditioning and heat pump equipment on the basis of weighted operation at various load capacities.
3. All RGS units comply with ASHRAE 90.1 2001, 2004 Energy Standard for minimum SEER and EER requirements.
4. RGS units comply with US Energy Policy Act (2005). To evaluate code compliance requirements, refer to state and local codes or visit the following website: <http://bcap-energy.org> to determine if compliance with this standard pertains to your state, territory, or municipality.



Use of the AHRI Certified TM Mark indicates a manufacturer's participation in the program. For verification of certification for individual products, go to www.ahridirectory.org.



Table 3 – SOUND PERFORMANCE TABLE

MODEL RGS	COOLING STAGES	Outdoor Sound (dB)									
		A-Wtg.	ARI 370 Rating	63	125	250	500	1000	2000	4000	8000
210	2	84.1	84	92.2	83.9	80.4	81.8	78.7	76.5	72.2	65.4
240	2	86.5	87	95.6	87.5	84.2	84.2	81.7	77.9	73.2	66.3
300	2	85.9	86	97.1	88.3	84.4	83.3	80.7	77.4	73.4	67.3
336	2	85.9	86	97.1	88.3	84.4	83.3	80.7	77.4	73.4	67.3

LEGEND

dB – Decibel

NOTES:

1. Outdoor sound data is measured in accordance with AHRI standard 270-2008.
2. Measurements are expressed in terms of sound power. Do not compare these values to sound pressure values because sound pressure depends on specific environmental factors which normally do not match individual applications. Sound power values are independent of the environment and therefore more accurate.
3. A-weighted sound ratings filter out very high and very low frequencies, to better approximate the response of "average" human ear. A-weighted measurements are taken in accordance with AHRI standard 270-2008.

Table 4 – HEATING RATING TABLE – NATURAL GAS & PROPANE

MODEL RGS	HEAT SIZE	AL/SS HEAT EXCHANGER		TEMP RISE (DEG F)	THERMAL EFFICIENCY (%)
		INPUT / OUTPUT STAGE 2 (MBH)	INPUT / OUTPUT STAGE 1 (MBH)		
210	LOW	220 / 178	176 / 142	15 – 55	81%
	MED	310 / 251	248 / 200	25 – 60	81%
	HIGH	400 / 324	320 / 260	30 – 65	81%
240	LOW	220 / 178	176 / 142	15 – 55	81%
	MED	310 / 251	248 / 200	20 – 60	81%
	HIGH	400 / 324	320 / 260	30 – 65	81%
300	LOW	220 / 178	176 / 142	10 – 55	81%
	MED	310 / 251	248 / 200	15 – 60	81%
	HIGH	400 / 324	320 / 260	20 – 65	81%
336	LOW	220 / 178	176 / 142	10 – 55	81%
	MED	310 / 251	248 / 200	15 – 60	81%
	HIGH	400 / 324	320 / 260	20 – 65	81%

NOTE:

Heat ratings are for natural gas heat exchangers operated at or below 2000 ft. For information on Propane or altitudes above 2000 ft (610m), see the Application Data section of this book. Accessory Propane/High Altitude kits are also available.

In the USA the input rating for altitudes above 2000 ft (610m) must be derated by 4% for each 1000 ft (305 m) above sea level. In Canada, the input rating must be derated by 10% for altitudes of 2000 ft (610 m) to 4500 ft (1372 m) above sea level.

Table 5 – MINIMUM – MAXIMUM AIRFLOW RATINGS – NATURAL GAS & LIQUID PROPANE

MODEL RGS	HEAT SIZE	COOLING	COOLING	COOLING		AL HX HEATING		SS HX HEATING	
		Minimum Single Speed Fan Motor	Minimum 2-Speed Fan Motor (at High Speed)	Minimum 2-Speed Fan Motor (at Low Speed)	Maximum	Minimum	Maximum	Minimum	Maximum
210	LOW	5250	5250	3465	9000	3000	11000	3000	11000
	MED					3880	9300	3880	9300
	HIGH					4620	10000	4620	10000
240	LOW	6000	6000	3960	10000	3000	11000	3000	11000
	MED					3880	11630	3880	11630
	HIGH					4620	10000	4620	10000
300	LOW	7500	8450	5577	12500	3000	16500	3000	16500
	MED					3880	15500	3880	15500
	HIGH					4620	15000	4620	15000
336	LOW	8250	8250	5445	13750	3000	16500	3000	16500
	MED					3880	15500	3880	15500
	HIGH					4620	15000	4620	15000

AL = Aluminum Gas Heat Exchanger

SS = Stainless Steel Gas Heat Exchanger

Table 6 – PHYSICAL DATA (2–STAGE COOLING) 17.5 – 27.5 TONS

RGS		210	210 w/Hot Gas Reheat	240	240 w/Hot Gas Reheat
Refrigeration System		RTPF	RTPF	RTPF	RTPF
# Circuits / # Comp. / Type		2 / 2 / Scroll	2 / 2 / Scroll	2 / 2 / Scroll	2 / 2 / Scroll
R–410a charge A/B (lbs)		16.3/17.5	25.9/25.7	20.6/14.7	27.9/20.5
Metering device		Acutrol	TXV	Acutrol	TXV
High–press. Trip / Reset (psig)		630 / 505	630 / 505	630 / 505	630 / 505
Low–press. Trip / Reset (psig)		54 / 117	27 / 44	54 / 117	27 / 44
Evap. Coil					
Material		Cu / Al	Cu / Al	Cu / Al	Cu / Al
Tube Diameter		3/8"	3/8"	3/8"	3/8"
Rows / FPI		4 / 15	4 / 15	4 / 15	4 / 15
Total face area (ft ²)		22.00	22.00	22.00	22.00
Condensate drain conn. size		3/4"	3/4"	3/4"	3/4"
Hot Gas Reheat Coil					
Material		n/a	Cu / Al	n/a	Cu / Al
Tube Diameter		n/a	3/8"	n/a	3/8"
Rows / FPI		n/a	1 / 17	n/a	1 / 17
Total face are (ft ²)		n/a	22.00	n/a	22.00
Evap. fan and motor					
Standard Static	Motor Qty / Belt Qty / Driver Type	1 / 1 / Belt	1 / 1 / Belt	1 / 1 / Belt	1 / 1 / Belt
	Max BHP	3.3	3.3	4.9	4.9
	RPM range	622–822	622–822	690–863	690–863
	motor frame size	56	56	56	56
	Fan Qty / Type	2 / Centrifugal	2 / Centrifugal	2 / Centrifugal	2 / Centrifugal
	Fan Diameter (in)	15 x 15	15 x 15	15 x 15	15 x 15
Medium Static	Motor Qty / Belt Qty / Driver Type	1 / 1 / Belt	1 / 1 / Belt	n/a	n/a
	Max BHP	4.9	4.9	n/a	n/a
	RPM range	713–879	713–879	n/a	n/a
	motor frame size	56	56	n/a	n/a
	Fan Qty / Type	2 / Centrifugal	2 / Centrifugal	n/a	n/a
	Fan Diameter (in)	15 x 15	15 x 15	n/a	n/a
High Static	Motor Qty / Belt Qty / Driver Type	n/a	n/a	1 / 1 / Belt	1 / 1 / Belt
	Max BHP	n/a	n/a	6.5/ 6.9/ 7.0/ 8.3	6.5/ 6.9/ 7.0/ 8.3
	RPM range	n/a	n/a	835–1021	835–1021
	motor frame size	n/a	n/a	184T	184T
	Fan Qty / Type	n/a	n/a	2 / Centrifugal	2 / Centrifugal
	Fan Diameter (in)	n/a	n/a	15 x 15	15 x 15
High Static–High Efficiency	Motor Qty / Belt Qty / Driver Type	1 / 1 / Belt	1 / 1 / Belt	1 / 1 / Belt	1 / 1 / Belt
	Max BHP (208/230/460/575v)	6.5/ 6.9/ 7.0/ 8.3	6.5/ 6.9/ 7.0/ 8.3	10.5/11.9/11.9/11	10.5/11.9/11.9/11
	RPM range	882–1078	882–1078	941–1176	941–1176
	motor frame size	184T	184T	213T	213T
	Fan Qty / Type	2 / Centrifugal	2 / Centrifugal	2 / Centrifugal	2 / Centrifugal
	Fan Diameter (in)	15 x 15	15 x 15	15 x 15	15 x 15

Table 6 (Cont.) PHYSICAL DATA (2-STAGE COOLING) 17.5 – 27.5 TONS

Refrigeration System		RGS	300	300 w/Hot Gas Reheat	336
			RTPF	RTPF	RTPF
# Circuits / # Comp. / Type R-410a charge A/B (lbs) Metering device High—press. Trip / Reset (psig) Low—press. Trip / Reset (psig)			2 / 2 / Scroll 19.8/ 20.4 Acutrol 630 / 505 54 / 117	2 / 2 / Scroll 27.9/ 28.9 TXV 630 / 505 27 / 44	2 / 2 / Scroll 27.0/ 28.5 Acutrol 630 / 505 54 / 117
Evap. Coil					
Material Tube Diameter Rows / FPI Total face area (ft ²) Condensate drain conn. size			Cu / Al 3/8" 4 / 15 23.11 3/4"	Cu / Al 3/8" 4 / 15 23.11 3/4"	Cu / Al 3/8" 4 / 15 26 3/4"
Hot Gas Reheat Coil					
Material Tube Diameter Rows / FPI Total face are (ft ²)			n/a n/a n/a n/a	Cu / Al 3/8" 1 / 17 23.11	Cu / Al 3/8" 4 / 15 26
Evap. fan and motor					
<div style="border: 1px solid black; padding: 5px; width: fit-content;"> Standard Static </div>	Motor Qty / Belt Qty / Driver Type Max BHP RPM range motor frame size Fan Qty / Type Fan Diameter (in)		1 / 1 / Belt 4.9 717–911 56 2 / Centrifugal 15 x 15	1 / 1 / Belt 4.9 717–911 56 2 / Centrifugal 15 x 15	n/a n/a n/a n/a n/a n/a
	Motor Qty / Belt Qty / Driver Type Max BHP RPM range motor frame size Fan Qty / Type Fan Diameter (in)		n/a n/a n/a n/a n/a n/a	n/a n/a n/a n/a n/a n/a	1 / 1 / Belt 6.5/ 6.9/ 7.0/ 8.3 751–954 56 2 / Centrifugal 15 x 15
	Motor Qty / Belt Qty / Driver Type Max BHP (208/230/460/575v) RPM range motor frame size Fan Qty / Type Fan Diameter (in)		1 / 1 / Belt 6.5/ 6.9/ 7.0/ 8.3 913–1116 184T 2 / Centrifugal 15 x 15	1 / 1 / Belt 6.5/ 6.9/ 7.0/ 8.3 913–1116 184T 2 / Centrifugal 15 x 15	1 / 1 / Belt 10.5/11.9/11.9/11 920–1190 184T 2 / Centrifugal 15 x 15
	Motor Qty / Belt Qty / Driver Type Max BHP (208/230/460/575v) RPM range motor frame size Fan Qty / Type Fan Diameter (in)		1 / 1 / Belt 10.5/11.9/11.9/11 941–1176 213T 2 / Centrifugal 15 x 15	1 / 1 / Belt 10.5/11.9/11.9/11 941–1176 213T 2 / Centrifugal 15 x 15	1 / 2 Belt 11.9/12.9/12.9/14.1 1116–1400 213T 2 / Centrifugal 15 x 15
	Motor Qty / Belt Qty / Driver Type Max BHP (208/230/460/575v) RPM range motor frame size Fan Qty / Type Fan Diameter (in)		1 / 1 / Belt 10.5/11.9/11.9/11 941–1176 213T 2 / Centrifugal 15 x 15	1 / 1 / Belt 10.5/11.9/11.9/11 941–1176 213T 2 / Centrifugal 15 x 15	1 / 2 Belt 11.9/12.9/12.9/14.1 1116–1400 213T 2 / Centrifugal 15 x 15

Table 6 (Cont.) PHYSICAL DATA (2-STAGE COOLING) 17.5 – 27.5 TONS

RGS	210	240	300	336
Cond. Coil (Circuit A)				
Coil type	RTPF	RTPF	RTPF	RTPF
Coil Length (in)	70	82	75	95
Coil Height (in)	44	44	52	52
Number of Passes Rows / FPI	2 / 17	2 / 17	2 / 17	2 / 17
total face area (ft2)	21.4	25.1	27.1	34.3
Cond. Coil (Circuit B)				
Coil type	RTPF	RTPF	RTPF	RTPF
Coil Length (in)	70	57	75	95
Coil Height (in)	44	44	52	52
Rows / FPI	2 / 17	2 / 17	2 / 17	2 / 17
total face area (ft2)	21.4	17.4	27.1	34.3
Cond. fan / motor				
Qty / Motor drive type	3 / direct	4 / direct	4 / direct	6 / direct
Motor HP / RPM	1/4 / 1100	1/4 / 1100	1/4 / 1100	1/4 / 1100
Fan diameter (in)	22	22	22	22
Filters				
RA Filter # / size (in)	6 / 20 x 25 x 2	6 / 20 x 25 x 2	9 / 16 x 25 x 2	9 / 16 x 25 x 2
OA inlet screen # / size (in)	4 / 16 x 25 x 1	4 / 16 x 25 x 1	4 / 16 x 25 x 1	4 / 16 x 25 x 1

Table 7 – PHYSICAL DATA (HEATING) 17.5 – 27.5 TONS

		RGS	210	240	300	336
			1 5 –13 / 0.18–0.47 11–13 / 0.40–0.47	1 5 –13 / 0.18–0.47 11–13 / 0.40–0.47	1 5 –13 / 0.18–0.47 11–13 / 0.40–0.47	1 5 –13 / 0.18–0.47 11–13 / 0.40–0.47
Gas Connection						
Heat Anticipator setting (Amps)			0.14 0.14	0.14 0.14	0.14 0.14	0.14 0.14
Natural Gas Heat						
LOW	# of stages / # of burners (total)		2 / 5	2 / 5	2 / 5	2 / 5
	Connection Size		3/4" NPT	3/4" NPT	3/4" NPT	3/4" NPT
	Rollout switch opens / closes		195 / 115	195 / 115	195 / 115	195 / 115
	Temperature Rise		25 – 55	25 – 55	25 – 55	25 – 55
MED	# of stages / # of burners (total)		2 / 7	2 / 7	2 / 7	2 / 7
	Connection Size		3/4" NPT	3/4" NPT	3/4" NPT	3/4" NPT
	Rollout switch opens / closes		195 / 115	195 / 115	195 / 115	195 / 115
	Temperature Rise		30– 60	30– 60	30– 60	30– 60
HIGH	# of stages / # of burners (total)		2 / 10	2 / 10	2 / 10	2 / 10
	Connection Size		3/4" NPT	3/4" NPT	3/4" NPT	3/4" NPT
	Rollout switch opens / closes		195 / 115	195 / 115	195 / 115	195 / 115
Liquid Propane Heat						
LOW	# of stages / # of burners (total)		2 / 5	2 / 5	2 / 5	2 / 5
	Connection Size		3/4" NPT	3/4" NPT	3/4" NPT	3/4" NPT
	Rollout switch opens / closes		195 / 115	195 / 115	195 / 115	195 / 115
	Temperature Rise		25 – 55	25 – 55	25 – 55	25 – 55
MED	# of stages / # of burners (total)		2 / 7	2 / 7	2 / 7	2 / 7
	Connection Size		3/4" NPT	3/4" NPT	3/4" NPT	3/4" NPT
	Rollout switch opens / closes		196 / 115	197 / 115	198 / 115	199 / 115
	Temperature Rise		30– 60	30– 60	30– 60	30– 60
HIGH	# of stages / # of burners (total)		2 / 10	2 / 10	2 / 10	2 / 10
	Connection Size		3/4" NPT	3/4" NPT	3/4" NPT	3/4" NPT
	Rollout switch opens / closes		195 / 115	195 / 115	195 / 115	195 / 115
	Temperature Rise		35– 65	35– 65	35– 65	35– 65

BASE UNIT DIMENSIONS – RGS210

CONNECTION SIZES	
A	1 3/8" DIA [135] FIELD POWER SUPPLY KNOCKOUT
B	3" DIA [76] FIELD POWER SUPPLY KNOCKOUT
C	3 5/8" DIA [92] FIELD POWER SUPPLY KNOCKOUT
D	7/8" DIA [22] FIELD CONTROL WIRING HOLE
E	3/4"-14 NPT CONDENSATE DRAIN
F	3/4"-14 NPT GAS CONNECTION (NOT SHOWN)
G	7/8" DIA [22] FIELD CONTROL WIRING KNOCKOUT

- NOTES:
1. DIMENSIONS ARE IN INCHES, DIMENSIONS IN [] ARE IN MILLIMETERS.
 2. CENTER OF GRAVITY
 3. DIRECTION OF AIR FLOW

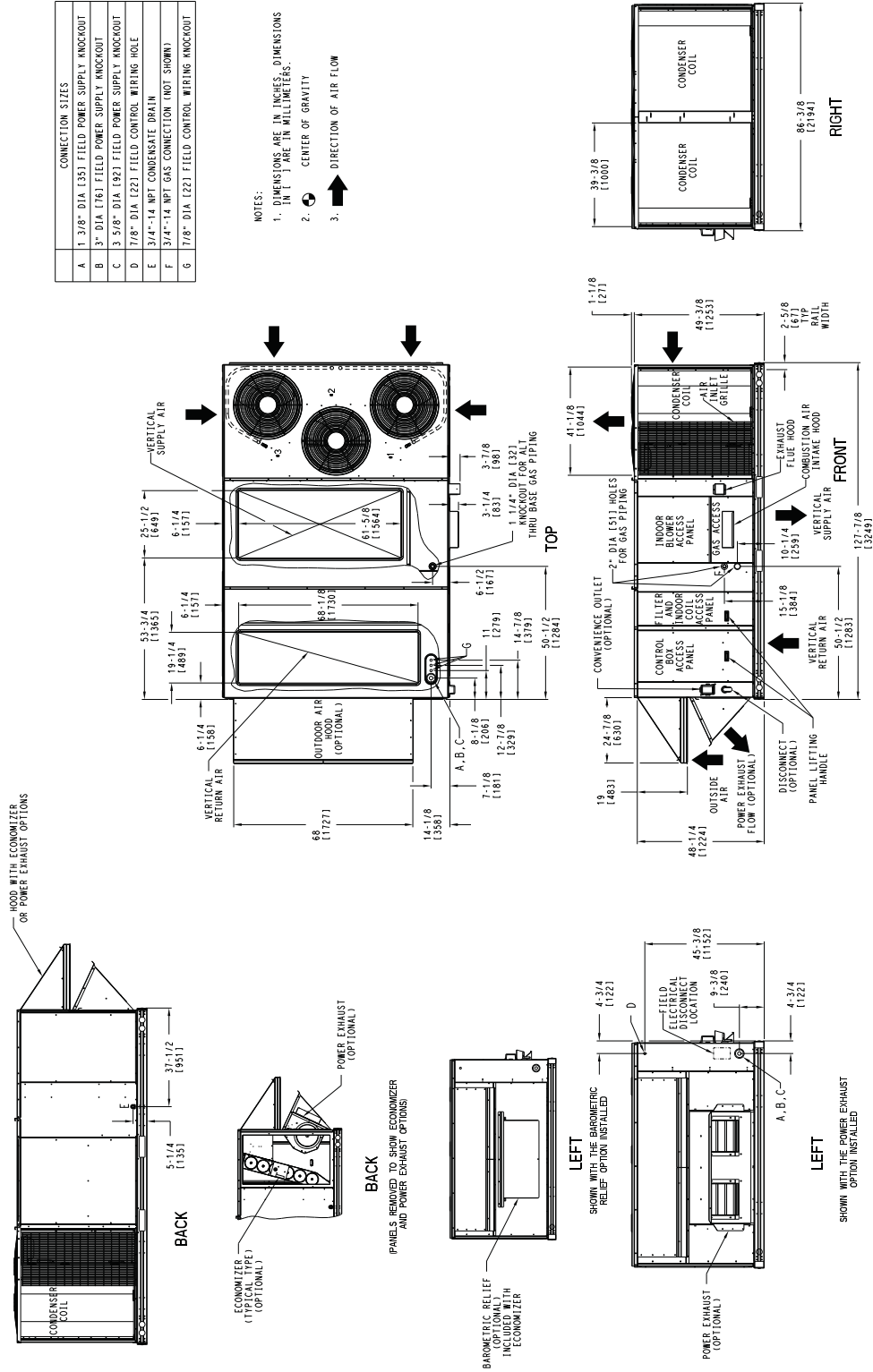

WEIGHT & DIMENSIONS – RGS210 (cont.)

UNIT RGS	MAX UNIT WEIGHT		Corner Weight A		Corner Weight B		Corner Weight C		Corner Weight D		Center of Gravity In [mm]		
	LBS	KG	LBS	KG	LBS	KG	LBS	KG	LBS	KG	X	Y	Z
210	1922	874	441	200	523	238	519	235	438	199	42-7/8 [1090]	69-1/4 [1759]	16-1/2 [419]

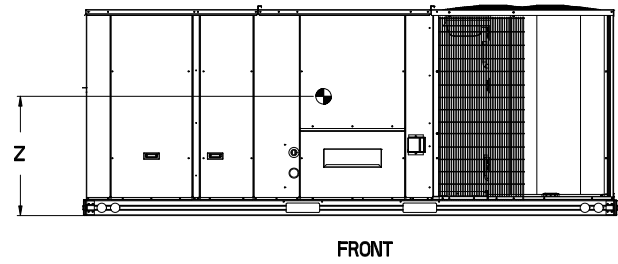
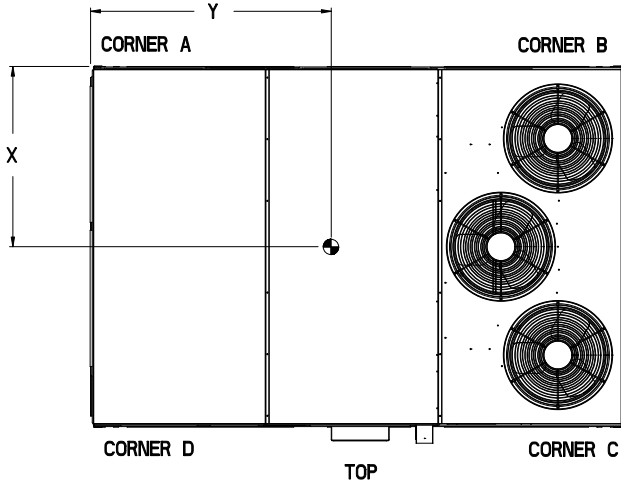

BASE UNIT DIMENSIONS - RGS240 - 300

CONNECTION SIZES	
A	1 3/8" DIA. (35) FIELD POWER SUPPLY KNOCKOUT
B	3" DIA. (76) FIELD POWER SUPPLY KNOCKOUT
C	3 5/8" DIA. (92) FIELD POWER SUPPLY KNOCKOUT
D	7/8" DIA. (22) FIELD CONTROL WIRING HOLE
E	3/4" x 1/4" NPT CONDENSATE DRAIN
F	3/4" x 1/4" NPT GAS CONNECTION (NOT SHOWN)
G	7/8" DIA. (22) FIELD CONTROL WIRING KNOCKOUT

UNIT	H
24 SIZE	11259
28 SIZE	11456

- NOTES:
1. DIMENSIONS ARE IN INCHES. DIMENSIONS IN \square ARE IN MILLIMETERS.
 2. CENTER OF GRAVITY
 3. DIRECTION OF AIR FLOW

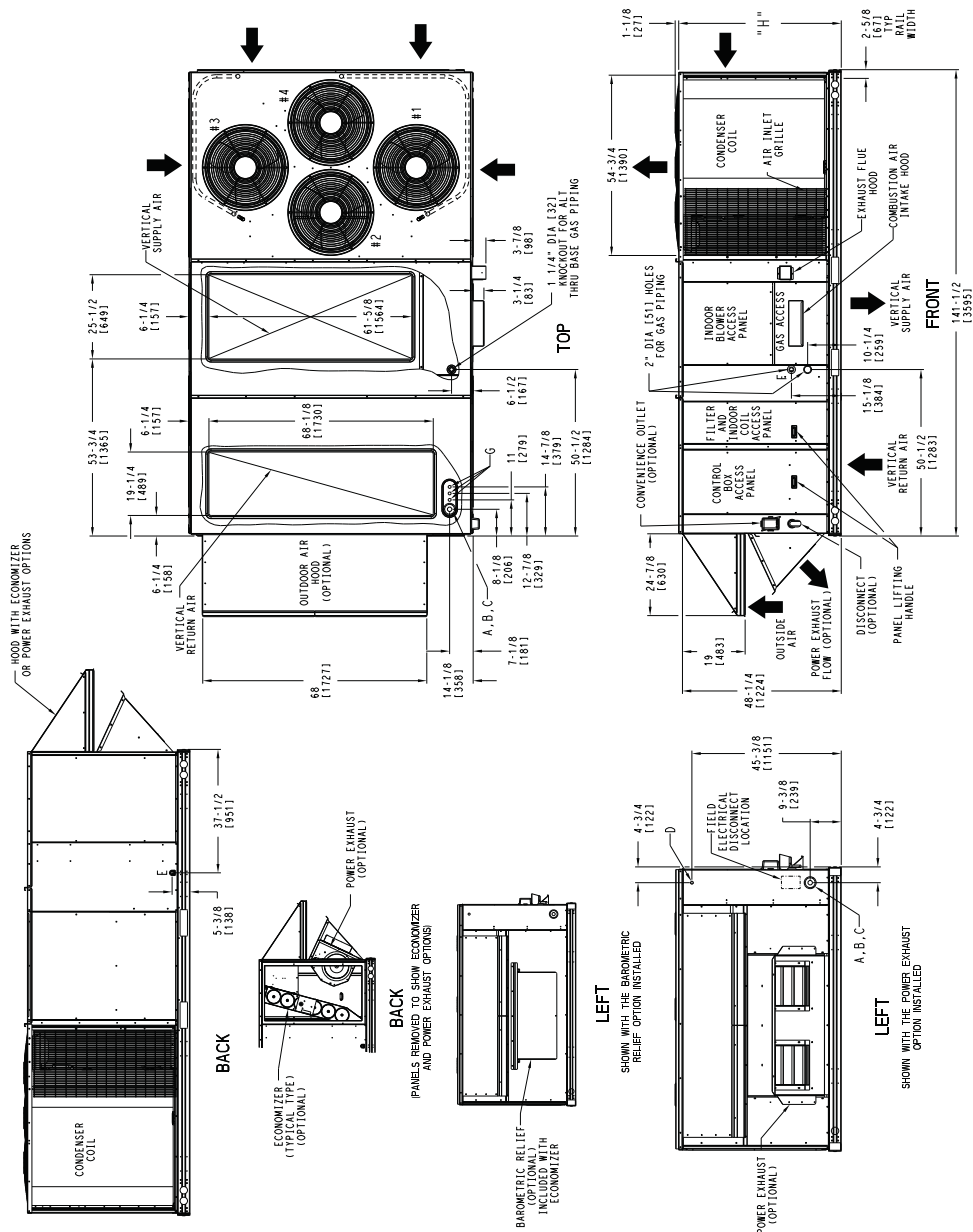

WEIGHT & CLEARANCE DIMENSIONS – RGS240–300 (cont.)

UNIT	Unit Weight		Corner Weight (A)		Corner Weight (B)		Corner Weight (C)		Corner Weight (D)		Center of Gravity In [mm]		
	Lb	Kg	Lb	Kg	Lb	Kg	Lb	Kg	Lb	Kg	X	Y	Z
240	2072	940	558	253	548	249	479	217	487	221	40-1/8 [1020]	70 [1778]	16-1/2 [419]
300	2197	997	571	259	564	256	528	239	534	242	41-5/8 [1058]	70-1/4 [1784]	19 [483]

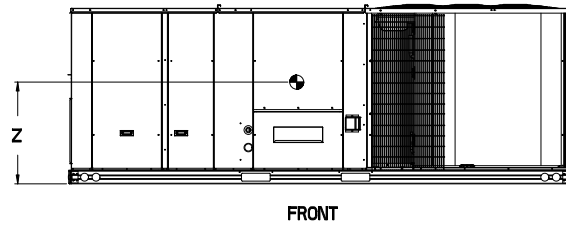
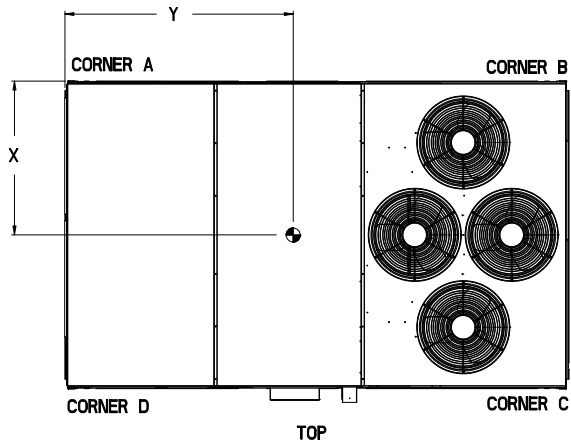

BASE UNIT DIMENSIONS – RGS336

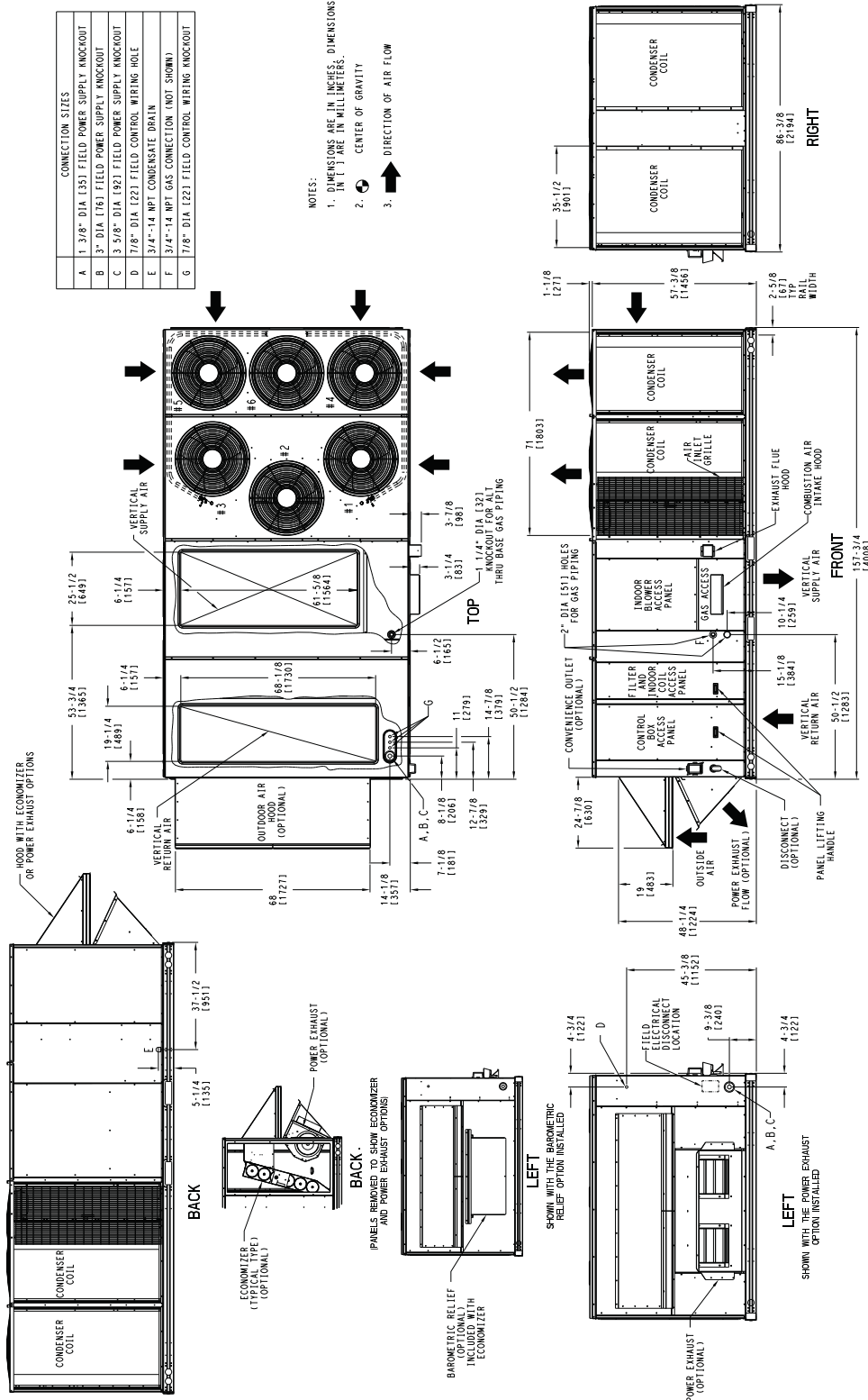

C13739

C11301

CLEARANCE DIMENSIONS

UNIT	Unit Weight		Corner Weight (A)		Corner Weight (B)		Corner Weight (C)		Corner Weight (D)		Center of Gravity In [mm]		
	Lb	Kg	Lb	Kg	Lb	Kg	Lb	Kg	Lb	Kg	X	Y	Z
336	2640	1200	697	317	595	270	621	282	728	331	44 [1118]	72-1/2 [1842]	19 [483]

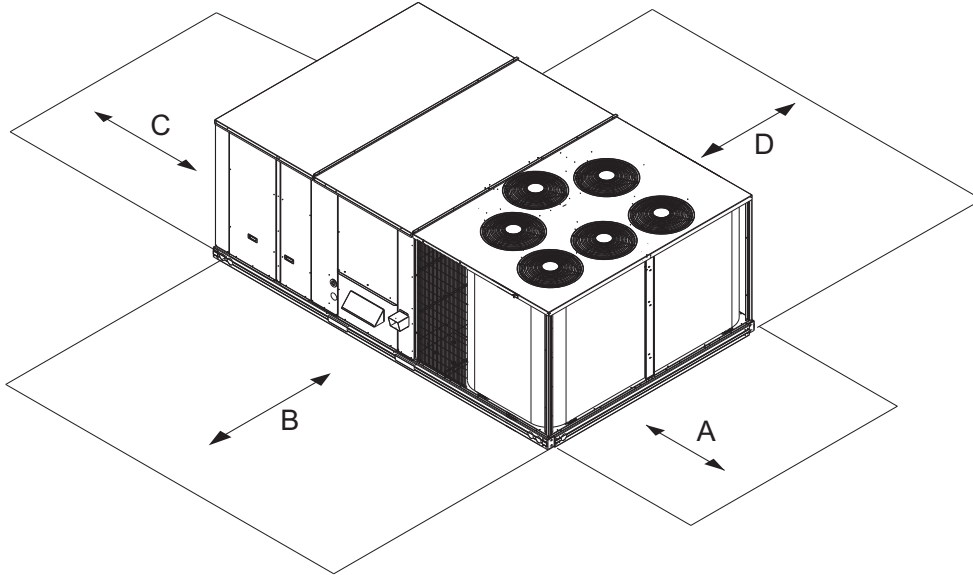

C11305

LOC	DIMENSION	CONDITION
A	36-in	Recommended clearance for airflow and service.
B	42-in	Recommended clearance for airflow and service.
C	18-in	1. No CO. 2. No Economizer. 3. No field installed disconnect on economizer hood side (Factory-installed disconnect installed).
	36-in	1. CO installed. 2. Vertical surface behind servicer is electrically non-conductive (e.g., wood, fiberglass).
	42-in	1. CO installed. 2. Vertical surface behind servicer is electrically conductive (e.g., metal, masonry)
	96-in	1. Economizer and/or Power Exhaust installed. 2. Check for sources of flue products within 10-ft of economizer fresh air intake.
D	42-in	Recommended clearance for service.

NOTE: Unit not designed to have overhead obstruction. Contact Application Engineering for guidance on any application planning overhead obstruction or for vertical clearances.

Table 8 – Operating Weights

RGS	UNIT LB (KG)			
	210	240	300	336
Base Unit				
RTPF Coil	1922 (874)	2072 (942)	2197 (999)	2640 (1200)
Economizer	246 (112)	246 (112)	246 (112)	246 (112)
Hot Gas Reheat System	110 (50)	120 (54)	120 (54)	N/A
Curb				
14-in/356 mm	240 (109)	255 (116)	255 (116)	255 (116)
24-in/610 mm	340 (154)	355 (161)	355 (161)	355 (161)

ROOF CURB DETAILS – RGS210

RoofCurb Accessory	A	Unit Size
CRRFCURB045A01	1' 2" [356]	RGS210
CRRFCURB046A01	2' 0" [610]	

NOTES:

1. Roofcurb accessory is shipped disassembled.
 2. Dimensions in. [] in millimeters.
 3. Roofcurb galvanized steel.
 4. Attach ductwork to curb (Flanges of duct rest on curb)
 5. Service clearance 4' on each side.
- ➡ Direction of airflow.

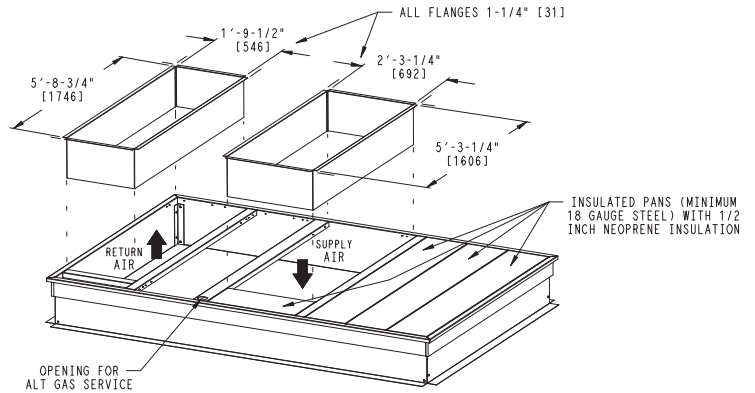
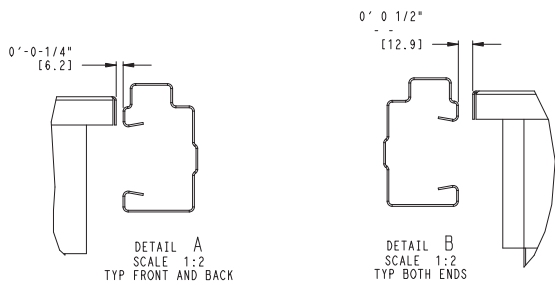
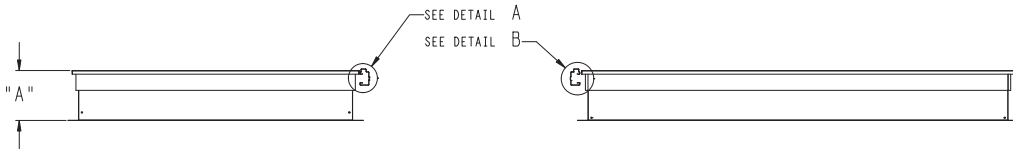
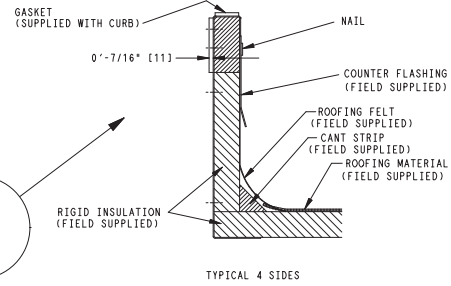
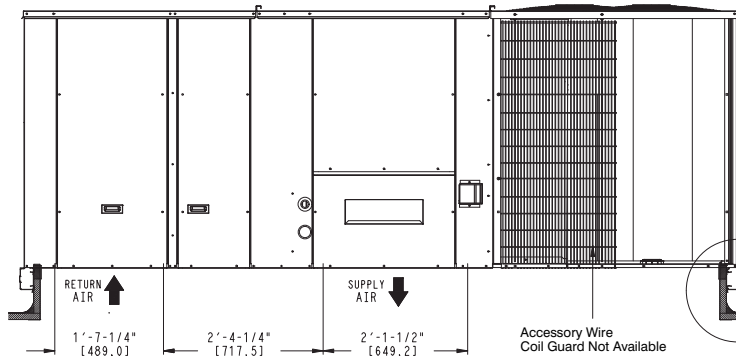
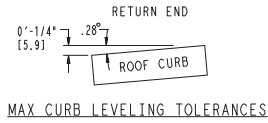
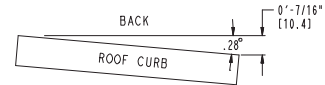
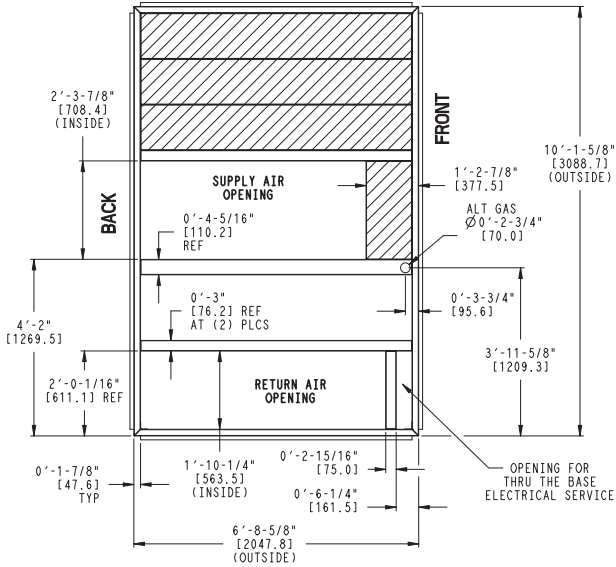

ROOF CURB DETAILS – RGS240 – 300

RoofCurb Accessory	A	Unit Size
CRRFCURB047A01	1' 2" [356]	RGS240
CRRFCURB048A01	2' 0" [610]	RGS300

NOTES:

1. Roofcurb accessory is shipped disassembled.
 2. Dimensions in. [] in millimeters.
 3. Roofcurb galvanized steel.
 4. Attach ductwork to curb (Flanges of duct rest on curb)
 5. Service clearance 4' on each side.
- ➡ Direction of airflow.

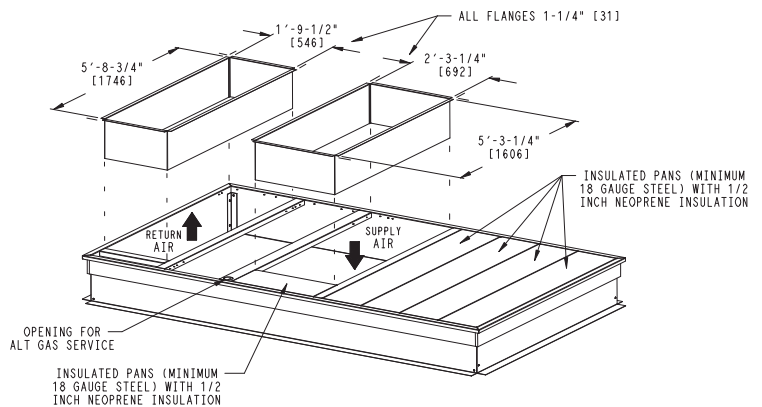
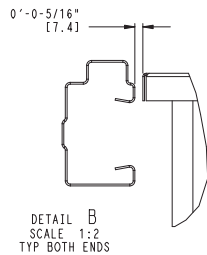
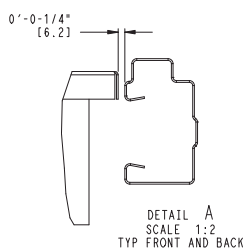
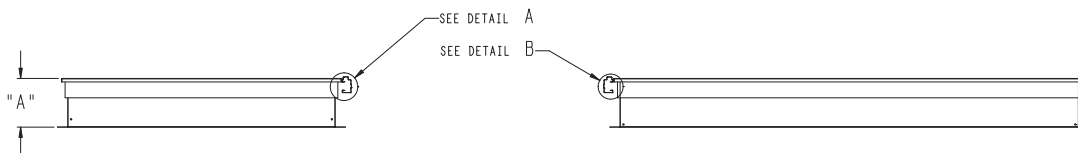
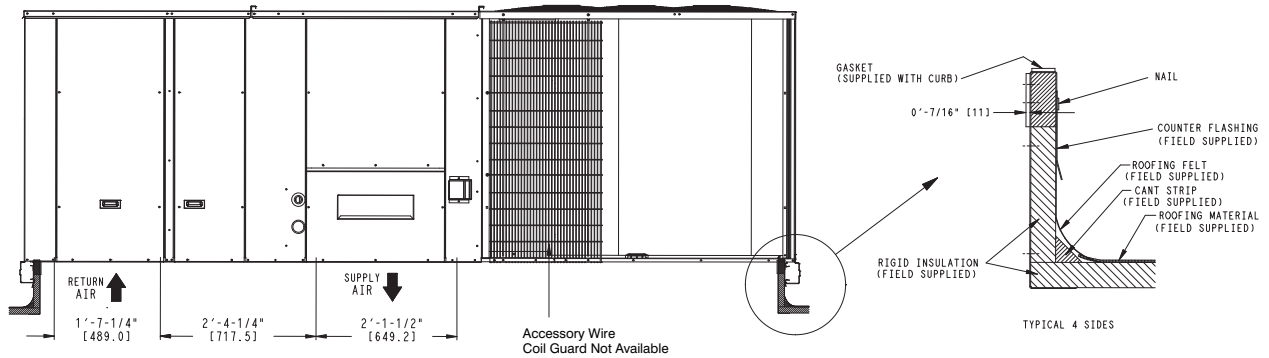
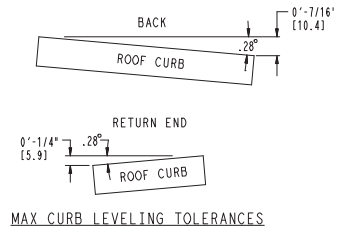
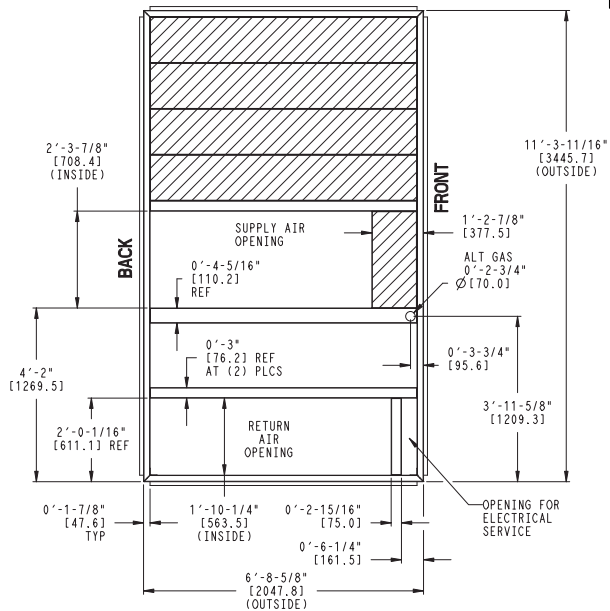

ROOF CURB DETAILS – RGS336

UNIT SIZE	"A"	ROOF CURB ACCESSORY
30	1'-2" [356.0] 2'-0" [610.0]	CRRFCURB049A00 CRRFCURB050A00

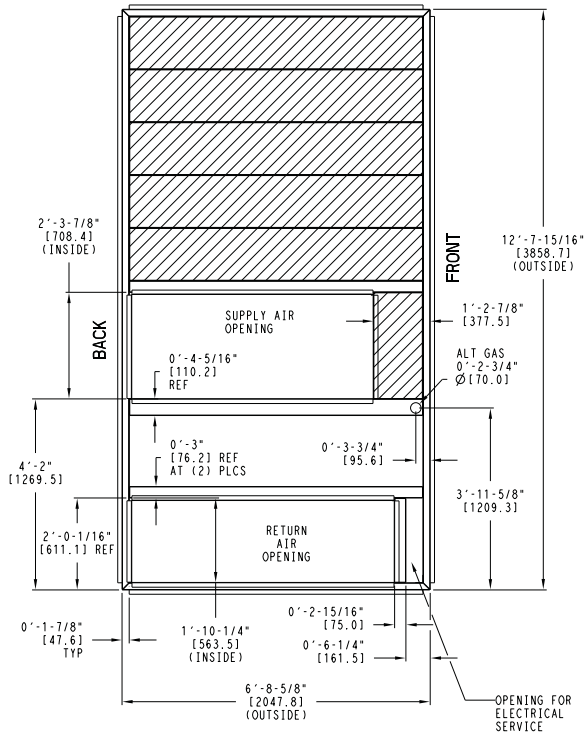

- NOTES:
- 1 ROOF CURB ACCESSORY IS SHIPPED UNASSEMBLED.
 - 2 BOLT HEADS TO BE ON INSIDE OF FLANGE. CLEARANCE IS (11) 0-0-7/16" TYP ALL CORNERS.
 - 3 DIMENSIONS IN [] ARE IN MILLIMETERS.
 - 4 ROOF CURB GALVANIZED STEEL.
 - 5 ATTACH DUCTWORK TO CURB (FLANGES ON DUCT REST ON CURB)
 - 6 SERVICE CLEARANCE 4 FI ON EACH SIDE
 - 7 GAS SERVICE PLATE IS PART OF A SEPERATELY SHIPPED ACCESSORY PACKAGE.
 - 8 GAS SERVICE PLATE CAN BE USED WITH EITHER ACCESSORY ROOFCURB.

➔ DIRECTION OF AIR FLOW

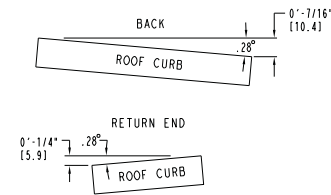

MAX CURB LEVELING TOLERANCES

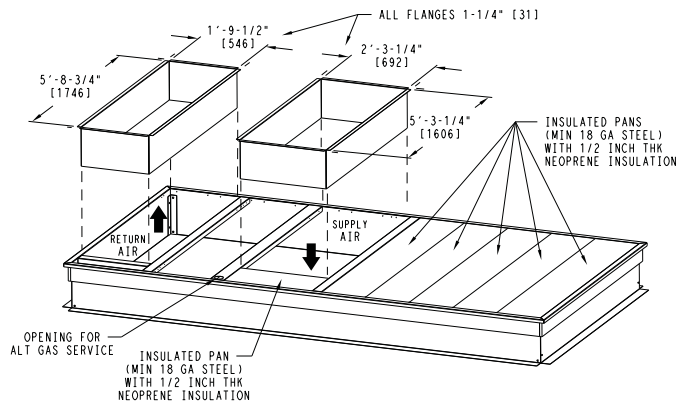
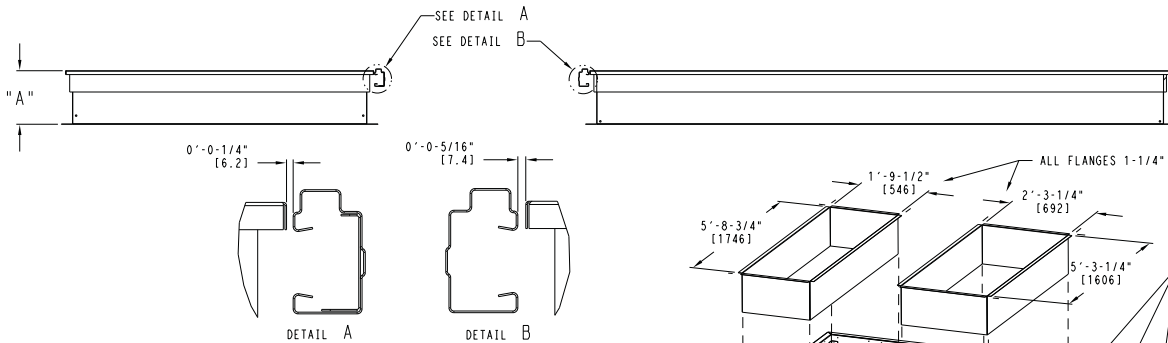
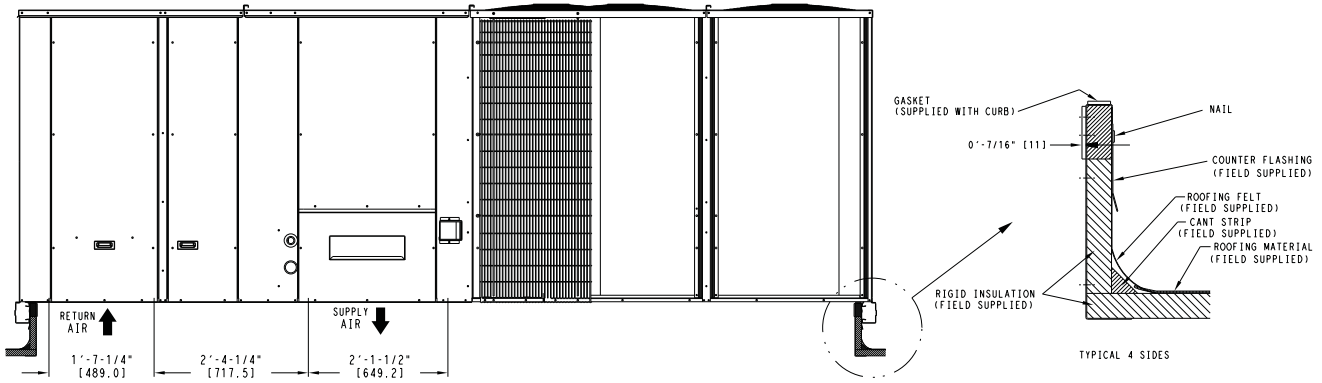

C11224

OPTIONS AND ACCESSORIES WEIGHT ADDERS

BASE UNIT WITH OPTIONS AND ACCESSORIES (Weight Adders)	MAX WEIGHT ADDER							
	210		240		300		336	
	lb	kg	lb	kg	lb	kg	lb	kg
Hot Gas Reheat	110	50	120	55	120	55	---	---
Power Exhaust	125	57	125	57	125	57	125	57
Economizer (IV or X)	246	112	246	112	246	112	246	112
Copper Tube/Fin Evaporator Coil	110	50	135	61	161	73	173	78
Medium Gas Heat	90	41	90	41	90	41	90	41
High Gas Heat	113	51	113	51	113	51	113	51
Flue Discharge Deflector	7	3	7	3	7	3	7	3
Roof Curb 14-in (356mm)	240	109	240	109	240	109	255	116
Roof Curb 24-in (610mm)	340	154	340	154	340	154	355	161
Louvered Hail Guard	60	27	120	54	135	61	150	68
CO ₂ sensor	5	2	5	2	5	2	5	2
Supply Smoke Detector	5	2	5	2	5	2	5	2
Non-Fused Disconnect	15	7	15	7	15	7	15	7
Non-Powered Convenience Outlet	5	2	5	2	5	2	5	2
Enthalpy Sensor	2	1	2	1	2	1	2	1
Differential Enthalpy Sensor	3	1	3	1	3	1	3	1
Two Position Motorized Damper	50	23	50	23	65	29	65	29
Manual Damper	35	16	35	16	40	18	40	18
Field Filter Track 4-in (102mm)	12	5	12	5	12	5	12	5
MotorMaster Controller	35	16	35	16	35	16	35	16
Medium Static Motor/Drive	6	3	6	3	6	3	10	5
High Static Motor/Drive	12	5	16	7	16	7	20	9
2-Speed Remote VFD Drive	20	9	20	9	20	9	20	9

APPLICATION DATA

Min operating ambient temp (cooling):

In mechanical cooling mode, your rooftop unit can safely operate down to an outdoor ambient temperature of 30°F (-1°C). It is possible to provide cooling at lower outdoor ambient temperatures by using less outside air, economizers, and/or accessory low ambient kits.

Max operating ambient temp (cooling):

The maximum operating ambient temperature for cooling mode is 115°F (46°C). While cooling operation above 115°F (46°C) may be possible, it could cause either a reduction in performance, reliability, or a protective action by the unit's internal safety devices.

Min mixed air temp (heating):

Using the factory settings, the minimum temperatures for the mixed air (the combined temperature of the warm return air and the cold outdoor air) entering the dimpled, gas heat exchangers are:

<u>Aluminized</u>	<u>Stainless Steel</u>
50°F (10°C) continuous	40°F (4°C) continuous
45°F (7°C) intermittent	35°F (2°C) intermittent

Operating at lower mixed-air temperatures may be possible, if a field-supplied, outdoor air thermostat initiates both heat stages when the temperature is less than the minimum temperatures listed above. Please contact your local representative for assistance.

Min and max airflow (heating and cooling):

To maintain safe and reliable operation of your rooftop, operate within the heating airflow limits during heating mode and cooling airflow limits during cooling mode. Operating above the max may cause blow-off, undesired airflow noise, or airflow related problems with the rooftop unit. Operating below the min may cause problems with coil freeze-up and unsafe heating operation. Heating and cooling limitations differ when evaluating operating CFM, the minimum value is the HIGHER of the cooling and heating minimum CFM values published in Table 5 and the maximum value is the LOWER of the cooling and heating minimum values published in Table 5.

Heating-to-cooling changeover:

This unit will automatically change from heating to cooling mode when using a thermostat with an auto-change-over feature.

Airflow:

All units are draw-through in cooling mode and blow-through in heating mode.

Outdoor air application strategies:

Economizers reduce operating expenses and compressor run time by providing a free source of cooling and a means of ventilation to match application changing needs. In fact, they should be considered for most applications. Also, consider the various economizer control methods and their benefits, as well as sensors required to accomplish your application goals.

Motor limits, break horsepower (BHP):

Due to internal design of units, the air path, and specially designed motors, the full horsepower (maximum continuous BHP) band can be used with the utmost confidence. There is no need for extra safety factors, as motors are designed and

rigorously tested to use the entire, listed BHP range without either nuisance tripping or premature motor failure.

Propane heating:

Propane has different physical qualities than natural gas. As a result, propane requires different fuel to air mixture. To optimize the fuel/air mixture for propane, a kit with different burner orifices in an easy to install accessory. To select the correct burner orifices or determine the heat capacity for an propane application, use either the selection software, or the unit's service manual.

High altitude heating:

High altitudes have less oxygen, which affects the fuel/air mixture in heat exchangers. In order to maintain a proper fuel/air mixture, heat exchangers operating in altitudes above 2000 ft (610 m) require different orifices. To select the correct burner orifices or determine the heat capacity for a high altitude application, use either the selection software, or the unit's service manual.

High altitudes have less oxygen, which means heat exchangers need less fuel. The new gas orifices in this field-installed kit make the necessary adjustment for high altitude applications. They restore the optimal fuel to air mixture and maintain healthy combustion on altitudes above 2000 ft (610 m).

NOTE: Typical natural gas heating value ranges from 975 to 1050 Btu/ft³ at sea level nationally. The heating value goes down approximately 1.7% per every thousand feet elevation. Standard factory orifices can typically be used up to 2000 ft (610m) elevation without any operational issues.

NOTE: For installations in Canada, the input rating should be derated by 10% for altitudes from 2000 ft (610m) to 4500 ft (1372m) above sea level.

Sizing a rooftop

While an air conditioner needs to have enough capacity to meet the design loads, it doesn't need excess capacity. In fact, excess capacity typically results in very poor part load performance and humidity control.

Using higher design temperatures than ASHRAE recommends for your location, adding "safety factors" to the calculated load, are all signs of oversizing air conditioners. Oversizing the air conditioner leads to poor humidity control, reduced efficiency, higher utility bills, larger indoor temperature swings, excessive noise, and increased wear and tear on the air conditioner.

Rather than oversizing an air conditioner, engineers should "right-size" or even slightly undersize air conditioners. Correctly sizing an air conditioner controls humidity better; promotes efficiency; reduces utility bills; extends equipment life, and maintains even, comfortable temperatures.

Low ambient applications

The optional economizer can adequately cool your space by bringing in fresh, cool outside air. In fact, when so equipped, accessory low-ambient kit may not be necessary. In low ambient conditions, unless the outdoor air is excessively humid or contaminated, economizer-based "free cooling" is the preferred less costly and energy conscious method.

In low ambient applications where outside air might not be desired (such as contaminated or excessively humid outdoor environments), your rooftop can operate to ambient temperatures down to -20°F (-29°C) using the recommended accessory Motormaster low ambient controller.

2-Speed Indoor Fan Motor System with Variable Frequency Drive (VFD)

The 2-Speed Indoor Fan Motor System utilizes a Variable Frequency Drive (VFD) to automatically adjust the indoor fan motor speed in sequence with the units cooling operation. Per ASHRAE 90.1 2010 standard section 6.4.3.10.b, during the first stage of cooling operation the VFD will adjust the fan motor to provide 2/3rd of the total cfm established for the unit. When a call for the second stage of cooling is required, the VFD will allow the total cfm for the unit established (100%). During the heating mode, the VFD will allow total design cfm (100%) operation and during the ventilation mode the VFD will allow operation to 2/3rd of total cfm.

The VFD used in the 2-Speed Indoor Fan Motor System has soft start capabilities to slowly ramp up the speeds, thus eliminating any high inrush air volume during initial start-up. It also has internal over current protection for the fan motor and a field installed display kit that allows adjustment and in depth diagnostics of the VFD.

This 2-Speed Indoor Fan Motor System is available on models with 2-stage cooling operation with electrical mechanical controls. Both space sensor and conventional thermostats/controls can be used to provide accurate control in any application.

The 2-Speed Indoor Fan Motor System is very flexible for initial fan performance set up and adjustment. The standard factory shipped VFD is pre programmed to automatically stage the fan speed between the first and second stage of cooling. The unit fan performance static pressure and cfm can be easily adjusted using the traditional means of pulley adjustments. The other means to adjust the unit static and cfm performance is to utilize the field installed display module and adjust the frequency and voltage in the VFD to required performance requirements. In either case, once set up the VFD will automatically adjust the speed between the cooling stage operation.

Table 9 – COOLING CAPACITIES 17.5 TONS (2 Stage Cooling)

RGS210			AMBIENT TEMPERATURE												
			85			95			105			115			
			EAT (DB)			EAT (DB)			EAT (DB)			EAT (DB)			
			75	80	85	75	80	85	75	80	85	75	80	85	
5250 Cfm	EAT (wb)	58	THC	180.4	185.6	196.3	167.7	176.1	186.9	154.7	165.3	176.6	142.2	153.6	164.9
		58	SHC	166.5	185.6	196.3	160.6	176.1	186.9	152.7	165.3	176.6	142.2	153.6	164.9
		62	THC	196.2	195.5	196.9	183.6	182.9	187.2	169.3	168.7	176.9	153.4	154.1	165.2
		62	SHC	146.8	172.1	194.7	141.4	166.6	187.2	135.4	160.5	176.9	128.6	152.5	165.2
		67	THC	216.7	215.9	215.2	204.9	204.1	203.1	190.6	189.7	189.0	174.8	174.0	173.3
	67	SHC	120.0	146.1	171.8	115.4	141.5	167.1	109.8	136.1	161.7	103.8	130.2	155.6	
	72	THC	237.4	236.8	236.0	226.0	225.1	224.2	212.8	211.9	211.0	197.3	196.4	195.5	
	72	SHC	92.0	118.3	144.3	87.8	114.3	140.4	83.0	109.6	135.8	77.6	104.2	130.6	
	76	THC	--	252.9	253.0	--	242.5	241.6	--	229.1	228.2	--	214.1	213.1	
	76	SHC	--	95.1	121.4	--	91.7	118.0	--	87.3	113.8	--	82.5	107.1	
6125 Cfm	EAT (wb)	58	THC	188.8	198.5	209.3	176.5	188.2	200.2	164.5	176.7	189.0	151.9	164.2	176.7
		58	SHC	180.4	198.5	209.3	174.4	188.2	200.2	164.5	176.7	189.0	151.9	164.2	176.7
		62	THC	205.2	204.6	209.6	191.8	191.5	200.4	176.6	177.6	189.2	159.9	164.2	176.9
		62	SHC	159.9	188.7	209.6	154.2	183.0	200.4	147.9	174.8	189.2	141.0	164.2	176.9
		67	THC	225.5	224.5	223.5	213.5	212.5	211.7	199.1	198.3	197.4	182.3	181.4	180.9
	67	SHC	128.3	158.4	187.8	123.8	154.1	183.5	118.4	148.9	178.1	112.2	142.7	171.6	
	72	THC	245.6	245.3	244.6	234.7	233.6	232.6	220.9	219.9	218.8	205.5	204.4	203.4	
	72	SHC	95.4	125.9	155.7	91.7	122.2	152.4	86.9	117.7	148.1	81.7	112.5	143.1	
	76	THC	--	262.0	261.2	--	250.7	250.1	--	237.3	236.2	--	221.6	220.6	
	76	SHC	--	99.5	129.4	--	95.9	126.2	--	91.8	122.4	--	87.0	117.8	
7000 Cfm	EAT (wb)	58	THC	197.4	209.8	221.3	186.1	199.1	211.7	173.8	186.9	200.1	160.3	173.5	186.9
		58	SHC	196.8	209.8	221.3	186.1	199.1	211.7	173.8	186.9	200.1	160.3	173.5	186.9
		62	THC	212.7	212.4	221.5	198.4	199.8	212.0	182.3	186.9	200.3	164.7	173.8	187.1
		62	SHC	173.4	205.1	221.5	167.4	197.4	212.0	160.8	186.8	200.3	153.4	173.8	187.1
		67	THC	233.7	232.5	231.4	220.8	219.8	218.9	205.6	204.5	204.1	187.8	186.8	188.0
	67	SHC	138.0	172.0	205.0	133.4	167.6	200.4	127.8	162.0	194.4	121.3	155.6	185.6	
	72	THC	254.3	253.3	252.8	242.7	241.5	240.3	228.0	226.8	225.7	211.8	210.6	209.3	
	72	SHC	101.3	135.4	169.2	97.3	131.8	165.9	92.3	127.2	161.5	86.9	121.8	156.3	
	76	THC	--	270.7	269.9	--	259.0	258.1	--	245.0	243.6	--	228.5	227.1	
	76	SHC	--	106.1	140.0	--	102.4	136.5	--	98.2	132.7	--	93.2	127.9	
7875 Cfm	EAT (wb)	58	THC	205.0	217.2	229.1	193.4	206.9	219.3	180.6	194.3	207.9	166.6	180.5	194.5
		58	SHC	205.0	217.2	229.1	193.4	206.9	219.3	180.6	194.3	207.9	166.6	180.5	194.5
		62	THC	216.7	217.4	229.4	202.5	207.1	219.6	185.9	194.5	208.4	168.4	180.7	194.7
		62	SHC	183.9	217.4	229.4	178.2	207.1	219.6	171.5	194.5	208.4	141.2	180.7	194.7
		67	THC	237.8	236.7	235.7	224.7	223.5	223.0	209.5	208.3	209.2	191.5	190.3	195.0
	67	SHC	144.6	182.4	219.3	140.3	178.2	213.7	134.9	172.7	205.9	113.6	166.2	195.0	
	72	THC	258.6	257.5	256.5	246.8	245.7	244.3	231.8	230.5	229.2	215.3	213.9	212.5	
	72	SHC	103.9	141.8	179.2	100.0	138.3	176.1	95.1	133.9	172.1	89.7	128.6	142.0	
	76	THC	--	275.4	274.2	--	262.7	261.8	--	248.7	247.6	--	231.9	230.5	
	76	SHC	--	109.5	147.0	--	105.7	143.6	--	101.5	139.9	--	96.6	135.4	
8750 Cfm	EAT (wb)	58	THC	211.3	223.6	235.9	199.7	213.4	225.7	186.4	200.7	214.3	172.1	186.5	200.9
		58	SHC	211.3	223.6	235.9	199.7	213.4	225.7	186.4	200.7	214.3	172.1	186.5	200.9
		62	THC	220.0	223.7	236.3	206.0	213.6	226.1	189.3	200.9	214.5	172.2	186.7	201.2
		62	SHC	194.0	223.7	236.3	188.5	213.6	226.1	181.3	200.9	214.5	172.2	186.7	201.2
		67	THC	241.1	240.1	239.7	227.9	226.6	226.9	212.7	211.4	214.9	194.4	193.0	201.4
	67	SHC	151.0	192.1	230.2	146.9	188.3	225.2	141.6	182.9	214.8	135.3	176.3	201.4	
	72	THC	262.2	261.0	259.7	250.0	248.8	247.7	235.0	233.5	232.1	218.1	216.6	215.2	
	72	SHC	106.5	148.1	189.0	102.5	144.5	186.0	97.8	140.4	182.1	92.4	135.3	177.1	
	76	THC	--	278.9	277.4	--	266.0	264.8	--	251.5	250.6	--	234.7	233.0	
	76	SHC	--	112.7	153.7	--	108.9	150.4	--	104.7	146.7	--	100.0	142.4	

NOTE: See Minimum–Maximum Airflow Ratings in Table 5. Do not operate outside these limits.

LEGEND:

- Do not operate
- Cfm – Cubic feet per minute (supply air)
- EAT(db) – Entering air temperature (dry bulb)
- EAT(wb) – Entering air temperature (wet bulb)
- SHC – Sensible heat capacity
- TC – Total capacity

TABLE 10 – COOLING CAPACITIES

2-STAGE COOLING

17.5 TONS (cont.)

17.5 TONS – UNIT WITH HOT GAS REHEAT IN SUBCOOLING MODE										
Temp (F) Air Entering Condenser (Edb)		AIR ENTERING EVAPORATOR – CFM								
		5,250			7,000			8,750		
		Air Entering Evaporator – Ewb (F)								
		72	67	62	72	67	62	72	67	62
75	TC	218.7	199.6	180.5	241.4	219.4	197.4	261.7	237.2	212.7
	SHC	99.9	123.9	147.8	112.7	136.9	161.1	122.9	147.3	171.7
	kW	11.81	11.56	11.20	13.81	13.48	13.16	14.82	14.58	14.16
85	TC	206.6	187.9	169.1	224.9	203.4	181.9	241.3	217.3	193.4
	SHC	78.9	108.4	137.9	92.2	122.1	152.0	103.0	133.1	163.3
	kW	13.18	12.53	12.53	15.18	14.85	14.52	16.21	15.85	15.54
95	TC	194.7	176.2	157.8	208.4	187.4	166.4	220.8	197.4	174.1
	SHC	57.8	92.9	128.0	71.7	107.3	142.9	83.0	118.9	154.9
	kW	14.56	14.21	13.88	16.56	16.21	15.87	17.56	17.22	16.01
105	TC	182.7	164.5	146.4	191.9	171.4	150.8	200.3	177.6	154.8
	SHC	36.8	77.4	118.1	51.3	92.5	133.8	63.0	104.7	146.4
	kW	15.93	15.58	15.20	17.94	17.58	17.22	18.95	18.59	18.24
115	TC	170.6	152.8	135.0	175.4	155.4	135.3	179.8	157.7	135.5
	SHC	15.7	62.0	108.2	30.8	77.8	124.7	43.0	90.5	128.0
	kW	17.31	16.95	16.58	19.32	18.95	18.58	20.32	19.96	19.59

17.5 TONS – UNIT WITH HOT GAS REHEAT IN HOT GAS REHEAT MODE										
Temp (F) Air Entering Condenser (Edb)		AIR ENTERING EVAPORATOR – Ewb (F)								
		75 Dry Bulb			75 Dry Bulb			75 Dry Bulb		
		62.5 Wet Bulb			64 Wet Bulb			65.3 Wet Bulb		
		(50% Relative)			(56% Relative)			(60% Relative)		
		Air Entering Evaporator – Cfm								
		5,250	7,000	8,750	5,250	7,000	8,750	5,250	7,000	8,750
80	TC	82.20	90.50	92.40	86.70	96.40	97.80	91.60	99.80	101.20
	SHC	18.20	29.40	41.60	8.60	17.20	27.50	0.50	9.30	13.20
	kW	12.64	12.73	12.88	12.78	13.06	13.15	12.96	13.07	13.22
75	TC	84.40	92.70	94.40	88.80	98.60	99.70	93.70	102.00	103.40
	SHC	19.70	31.30	43.50	10.10	18.80	29.20	12.10	10.80	15.30
	kW	12.60	12.71	12.85	12.75	13.02	13.12	12.93	13.03	13.19
70	TC	86.70	94.90	96.60	91.00	100.70	102.00	95.90	104.10	105.40
	SHC	21.30	32.80	44.80	11.60	20.40	30.70	3.80	12.30	16.50
	kW	12.56	12.66	12.82	12.70	12.99	13.08	12.89	13.00	13.14
60	TC	90.90	99.10	100.80	95.20	105.00	106.30	100.20	108.30	109.70
	SHC	24.80	36.00	48.20	14.90	23.90	35.90	7.20	15.60	19.60
	kW	12.49	12.60	12.75	12.64	12.92	13.02	12.83	12.93	13.09
50	TC	95.00	103.40	105.10	99.50	109.40	110.50	104.40	112.50	113.90
	SHC	28.10	39.30	51.30	18.20	27.20	37.40	10.30	18.90	23.20
	kW	12.43	12.53	12.67	12.57	12.86	12.95	12.76	12.87	13.02
40	TC	99.20	107.70	109.30	103.70	113.70	114.70	108.60	116.70	118.10
	SHC	31.40	42.50	54.40	21.30	30.40	40.50	13.40	22.00	26.50
	kW	12.35	12.45	12.61	12.50	12.79	12.87	12.68	12.80	12.94

LEGEND

- Edb** – Entering Dry–Bulb
- Ewb** – Entering Wet–Bulb
- kW** – Compressor Motor Power Input
- ldb** – Leaving Dry–Bulb
- lwb** – Leaving Wet–Bulb
- SHC** – Sensible Heat Capacity (1000 Btuh) Gross
- TC** – Total Capacity (1000 Btuh) Gross

NOTES:

1. Direct interpolation is permissible. Do not extrapolate.
2. The following formulas may be used:

$$t_{ldb} = t_{edb} - \frac{\text{sensible capacity (Btuh)}}{1.10 \times \text{cfm}}$$

t_{lwb} = Wet–bulb temperature corresponding to enthalpy of air leaving evaporator coil (h_{lwb})

$$h_{lwb} = h_{ewb} - \frac{\text{total capacity (Btuh)}}{4.5 \times \text{cfm}}$$

Where: h_{ewb} = Enthalpy of air entering evaporator coil

Table 11 – COOLING CAPACITIES 20 TONS (2 Stage Cooling)

RGS240			AMBIENT TEMPERATURE												
			85			95			105			115			
			EAT (DB)			EAT (DB)			EAT (DB)			EAT (DB)			
			75	80	85	75	80	85	75	80	85	75	80	85	
6000 Cfm	EAT (wb)	58	THC	213.1	217.2	228.7	199.9	207.5	219.4	184.8	195.8	208.4	169.6	182.6	195.6
		SHC	194.3	217.2	228.7	188.0	207.5	219.4	179.0	195.8	208.4	169.6	182.6	195.6	
		62	THC	230.0	229.4	230.4	217.5	217.0	219.7	202.5	201.9	208.8	184.9	184.9	195.9
		SHC	170.0	199.9	225.9	164.6	194.5	219.7	158.3	187.8	208.8	150.9	178.7	195.9	
		67	THC	251.5	251.1	250.6	239.4	238.7	238.1	225.4	224.7	224.0	208.8	208.2	207.4
	SHC	137.5	168.1	198.4	132.9	163.4	193.7	127.5	158.1	188.2	121.1	151.9	181.9		
	72	THC	274.0	273.8	273.5	262.3	261.7	261.0	248.2	247.4	246.6	232.2	231.3	230.5	
	SHC	104.3	135.1	165.6	100.1	130.9	161.4	95.1	125.9	156.6	89.6	120.5	151.3		
	76	THC	–	292.9	292.2	–	280.5	279.9	–	266.3	265.6	–	250.6	249.8	
	SHC	–	108.1	138.6	–	104.1	134.9	–	99.6	130.4	–	94.6	125.5		
7000 Cfm	EAT (wb)	58	THC	220.8	229.7	241.7	208.4	219.7	232.2	194.3	208.1	221.0	180.1	194.2	207.9
		SHC	211.0	229.7	241.7	203.1	219.7	232.2	194.3	208.1	221.0	180.1	194.2	207.9	
		62	THC	237.8	237.3	241.9	225.1	224.6	232.3	209.6	210.2	221.3	191.3	196.0	208.2
		SHC	183.3	217.8	241.9	178.2	212.1	232.3	171.8	203.8	221.3	164.3	196.0	208.2	
		67	THC	260.0	259.2	258.5	247.2	246.4	245.7	232.7	231.9	231.7	215.8	215.0	214.3
	SHC	146.0	181.0	215.7	141.3	176.5	211.2	136.0	171.3	206.3	129.8	165.3	199.4		
	72	THC	283.3	282.5	281.8	270.6	269.8	268.9	255.9	255.0	254.1	240.0	238.9	238.0	
	SHC	107.9	143.2	178.1	103.6	139.0	174.1	98.6	134.2	169.5	93.2	129.0	164.4		
	76	THC	–	302.3	301.6	–	289.1	288.4	–	274.4	273.6	–	257.9	256.8	
	SHC	–	112.3	147.5	–	108.3	143.7	–	103.9	139.4	–	98.9	134.5		
8000 Cfm	EAT (wb)	58	THC	232.1	243.6	256.1	219.8	233.4	246.0	206.9	221.3	234.5	192.1	206.8	221.2
		SHC	227.5	243.6	256.1	219.8	233.4	246.0	206.9	221.3	234.5	192.1	206.8	221.2	
		62	THC	247.8	247.1	256.4	234.7	235.5	246.2	218.7	221.1	234.7	199.5	207.0	221.4
		SHC	199.5	236.7	256.4	194.3	229.1	246.2	187.8	221.1	234.7	179.9	207.0	221.4	
		67	THC	270.2	269.3	268.3	257.0	256.1	255.2	242.1	241.0	240.3	224.5	223.5	223.1
	SHC	157.6	197.1	235.6	152.7	192.6	231.0	147.3	187.2	225.3	141.0	181.0	215.6		
	72	THC	294.1	293.1	292.2	280.7	279.7	278.4	265.9	264.7	263.8	248.9	247.6	246.6	
	SHC	114.8	154.6	193.9	110.3	150.4	190.0	105.4	145.6	185.5	99.7	140.1	180.2		
	76	THC	–	313.1	312.3	–	299.3	298.2	–	283.8	282.8	–	266.7	265.4	
	SHC	–	120.2	159.6	–	116.0	155.9	–	111.4	151.5	–	106.2	146.6		
9000 Cfm	EAT (wb)	58	THC	238.5	252.5	266.0	226.8	241.6	255.6	213.1	228.2	243.0	197.5	213.0	229.2
		SHC	238.5	252.5	266.0	226.8	241.6	255.6	213.1	228.2	243.0	197.5	213.0	229.2	
		62	THC	253.0	254.1	266.3	238.6	241.6	255.7	221.0	228.4	243.3	201.1	213.2	229.4
		SHC	211.9	249.1	266.3	206.2	241.6	255.7	199.2	228.4	243.3	164.2	213.2	229.4	
		67	THC	276.9	275.8	274.8	263.0	261.8	261.0	246.5	245.2	246.6	228.2	225.9	229.6
	SHC	165.6	209.9	252.2	160.7	205.1	247.0	154.9	199.3	238.5	132.3	192.7	229.6		
	72	THC	302.2	301.0	299.7	287.9	286.6	285.4	272.3	270.9	269.6	254.3	252.9	251.6	
	SHC	118.2	162.8	206.8	113.5	158.4	202.9	108.5	153.4	198.0	102.7	147.8	165.1		
	76	THC	–	322.0	320.8	–	307.7	306.1	–	291.4	289.9	–	275.1	272.5	
	SHC	–	124.5	168.7	–	120.4	164.9	–	115.6	160.5	–	110.9	155.3		
10,000 Cfm	EAT (wb)	58	THC	245.7	259.8	273.9	233.8	248.7	263.2	219.8	235.3	250.5	203.7	219.8	236.5
		SHC	245.7	259.8	273.9	233.8	248.7	263.2	219.8	235.3	250.5	203.7	219.8	236.5	
		62	THC	256.8	260.7	274.2	242.2	249.0	263.3	224.6	235.6	250.6	205.6	220.0	236.8
		SHC	223.8	258.4	274.2	218.1	249.0	263.3	211.0	235.6	250.6	199.3	220.0	236.8	
		67	THC	280.8	279.6	266.3	266.6	265.4	265.8	249.9	248.6	251.0	231.4	229.8	237.3
	SHC	173.2	221.8	266.3	168.3	217.0	258.7	162.6	211.4	250.7	156.4	204.7	237.3		
	72	THC	306.4	305.0	274.8	292.1	290.6	289.3	276.0	274.3	273.0	257.5	256.0	254.6	
	SHC	121.2	170.1	252.2	116.6	165.9	214.8	111.5	161.0	210.0	105.7	155.4	204.5		
	76	THC	–	326.2	299.7	–	311.4	310.0	–	295.2	293.2	–	277.0	275.3	
	SHC	–	128.2	206.8	–	124.0	172.9	–	119.5	168.9	–	114.3	163.8		

NOTE: See Minimum–Maximum Airflow Ratings in Table 5. Do not operate outside these limits.

LEGEND:

- Do not operate
- Cfm – Cubic feet per minute (supply air)
- EAT(db) – Entering air temperature (dry bulb)
- EAT(wb) – Entering air temperature (wet bulb)
- SHC – Sensible heat capacity
- TC – Total capacity

20 TONS – UNIT WITH HOT GAS REHEAT IN SUBCOOLING MODE										
Temp (F) Air Entering Condenser (Edb)		AIR ENTERING EVAPORATOR – CFM								
		6,000			8,000			10,000		
		Air Entering Evaporator – Ewb (F)								
		72	67	62	72	67	62	72	67	62
75	TC	263.0	240.4	217.7	301.0	274.0	246.9	336.9	305.6	274.4
	SHC	125.3	151.6	178.0	144.4	171.1	198.0	160.0	186.9	213.9
	kW	15.63	15.20	14.65	15.91	15.62	14.98	16.26	15.92	15.21
85	TC	248.2	226.1	204.0	279.2	252.9	226.6	308.4	278.2	248.0
	SHC	98.9	131.7	164.5	118.6	152.0	185.3	134.6	168.4	202.2
	kW	17.50	17.04	16.50	17.74	17.51	16.75	18.08	17.73	17.03
95	TC	233.4	211.8	190.2	257.3	231.8	206.4	279.8	250.7	221.5
	SHC	72.4	111.8	151.1	92.7	132.8	172.9	109.3	149.9	190.6
	kW	19.36	18.96	18.35	19.61	19.37	18.67	20.02	19.62	18.97
105	TC	218.6	197.5	176.5	235.4	210.7	186.1	251.3	223.2	195.1
	SHC	46.0	91.8	137.7	66.9	113.6	160.4	83.9	131.4	178.9
	kW	21.23	20.76	20.18	21.53	21.22	20.52	21.91	21.52	20.77
115	TC	203.7	183.3	162.8	213.5	189.7	165.8	222.7	195.7	168.7
	SHC	19.5	71.9	124.2	41.0	94.4	147.9	58.5	112.9	157.2
	kW	23.02	22.58	22.02	23.42	23.02	22.38	23.73	23.41	22.57

20 TONS – UNIT WITH HOT GAS REHEAT IN HOT GAS REHEAT MODE										
Temp (F) Air Entering Condenser (Edb)		AIR ENTERING EVAPORATOR – Ewb (F)								
		75 Dry Bulb			75 Dry Bulb			75 Dry Bulb		
		62.5 Wet Bulb			64 Wet Bulb			65.3 Wet Bulb		
		(50% Relative)			(56% Relative)			(60% Relative)		
		Air Entering Evaporator – Cfm								
		6,000	8,000	10,000	6,000	8,000	10,000	6,000	8,000	10,000
80	TC	91.50	100.80	109.50	95.80	105.70	112.40	102.30	110.80	118.60
	SHC	12.30	31.20	44.50	0.90	15.10	25.70	-6.50	3.60	13.90
	kW	14.82	15.01	15.24	15.35	15.45	15.52	15.56	15.65	15.73
75	TC	94.00	103.40	112.00	98.70	108.10	115.10	104.70	113.10	121.10
	SHC	13.60	32.40	45.70	2.00	16.00	26.60	-5.60	4.70	15.10
	kW	14.90	15.07	15.33	15.43	15.56	15.64	15.69	15.77	15.85
70	TC	96.50	106.00	114.30	100.90	110.60	117.20	107.20	115.80	123.50
	SHC	14.50	33.20	45.70	3.30	17.30	28.00	-4.00	5.90	16.20
	kW	14.97	15.17	15.41	15.50	15.66	15.75	15.80	15.87	15.94
60	TC	101.80	111.30	119.30	106.20	115.60	122.20	112.60	119.40	128.00
	SHC	16.70	35.50	48.60	5.60	19.40	30.30	-1.80	8.20	18.50
	kW	15.14	15.32	15.58	15.66	15.88	15.97	16.05	16.10	16.19
50	TC	107.20	116.40	124.30	111.50	120.70	127.30	117.70	125.20	132.90
	SHC	18.60	37.60	50.70	8.00	22.00	32.70	0.50	10.50	21.00
	kW	15.27	15.46	15.76	15.81	16.10	16.23	16.27	16.34	16.41
40	TC	112.20	121.80	129.20	116.60	125.70	132.00	123.20	130.00	138.00
	SHC	21.80	39.50	52.90	10.20	24.40	35.20	2.90	13.00	23.40
	kW	15.42	15.63	15.93	15.96	16.32	16.44	16.52	16.57	16.65

LEGEND

- Edb** – Entering Dry–Bulb
- Ewb** – Entering Wet–Bulb
- kW** – Compressor Motor Power Input
- ldb** – Leaving Dry–Bulb
- lwb** – Leaving Wet–Bulb
- SHC** – Sensible Heat Capacity (1000 Btuh) Gross
- TC** – Total Capacity (1000 Btuh) Gross

NOTES:

1. Direct interpolation is permissible. Do not extrapolate.
2. The following formulas may be used:

$$t_{ldb} = t_{edb} - \frac{\text{sensible capacity (Btuh)}}{1.10 \times \text{cfm}}$$

$$t_{lwb} = \text{Wet–bulb temperature corresponding to enthalpy of air leaving evaporator coil } (h_{lwb})$$

$$h_{lwb} = h_{ewb} - \frac{\text{total capacity (Btuh)}}{4.5 \times \text{cfm}}$$

Where: h_{ewb} = Enthalpy of air entering evaporator coil

Table 13 – COOLING CAPACITIES 25 TONS (2 Stage Cooling)

RGS300			AMBIENT TEMPERATURE												
			85			95			105			115			
			EAT (DB)			EAT (DB)			EAT (DB)			EAT (DB)			
			75	80	85	75	80	85	75	80	85	75	80	85	
7,500 Cfm	EAT (wb)	58	THC	257.3	266.5	279.6	247.5	255.4	269.0	231.5	243.3	257.2	214.3	229.2	243.7
		58	SHC	247.5	266.5	279.6	231.1	255.4	269.0	223.5	243.3	257.2	213.2	229.2	243.7
		62	THC	281.4	280.5	280.6	267.5	267.0	269.3	251.3	251.0	257.6	232.7	232.5	244.1
		62	SHC	208.2	244.0	278.0	202.3	238.4	269.3	195.8	231.5	257.6	188.1	223.4	244.1
		67	THC	307.4	306.4	305.7	293.0	292.2	291.4	276.9	276.2	275.4	259.7	259.2	258.8
	67	SHC	168.7	205.7	242.3	163.2	200.3	236.9	157.1	194.4	230.7	150.6	188.4	224.8	
	72	THC	333.9	333.2	332.5	320.1	319.3	318.6	304.5	303.7	302.7	287.2	285.3	284.5	
	72	SHC	128.1	165.4	202.3	123.1	160.6	197.8	117.6	155.1	192.5	111.5	149.0	186.6	
	76	THC	–	356.0	355.2	–	342.0	341.2	–	326.0	325.2	–	308.0	307.4	
	76	SHC	–	132.7	169.9	–	128.1	165.6	–	123.0	160.7	–	117.3	154.5	
8,750 Cfm	EAT (wb)	58	THC	269.8	280.2	294.4	255.3	268.9	283.2	241.1	256.1	270.7	225.5	241.3	257.3
		58	SHC	257.9	280.2	294.4	250.4	268.9	283.2	241.1	256.1	270.7	225.5	241.3	257.3
		62	THC	289.9	289.3	294.6	275.3	274.9	283.6	258.7	258.2	271.0	238.8	241.6	257.6
		62	SHC	224.2	265.0	294.6	218.6	258.6	283.6	212.0	251.7	271.0	203.9	241.6	257.6
		67	THC	316.2	315.7	314.5	301.7	300.8	299.8	285.1	284.2	283.4	266.7	266.0	265.2
	67	SHC	179.0	221.6	263.1	173.5	216.4	257.9	167.5	210.5	251.9	161.0	204.5	245.1	
	72	THC	343.7	342.7	341.6	315.3	327.9	327.0	313.1	311.4	310.4	294.3	293.2	292.2	
	72	SHC	132.4	175.4	217.7	127.6	170.7	213.3	122.0	165.3	208.3	115.6	159.2	202.5	
	76	THC	–	366.0	364.9	–	351.2	350.1	–	334.2	333.2	–	315.4	314.3	
	76	SHC	–	138.0	180.7	–	133.4	176.5	–	128.2	171.6	–	122.5	166.1	
10,000 Cfm	EAT (wb)	58	THC	277.1	291.8	306.8	264.9	280.2	295.3	251.2	267.0	282.3	235.1	252.2	268.1
		58	SHC	275.3	291.8	306.8	264.9	280.2	295.3	251.2	267.0	282.3	235.1	252.2	268.1
		62	THC	296.8	296.0	307.2	281.8	281.8	295.6	264.7	267.1	282.6	244.9	252.4	268.4
		62	SHC	239.8	283.9	307.2	234.0	276.8	295.6	227.5	267.1	282.6	219.4	252.4	268.4
		67	THC	323.5	322.6	321.4	308.5	307.4	306.5	291.3	290.2	289.3	272.5	271.5	270.8
	67	SHC	188.8	236.9	282.9	183.5	231.9	277.4	177.5	226.1	271.2	171.2	219.7	264.3	
	72	THC	351.8	350.5	349.2	336.6	335.4	334.1	319.7	318.3	317.1	300.2	298.9	297.8	
	72	SHC	136.6	185.1	232.8	131.6	180.4	228.6	126.0	175.1	223.7	119.7	169.1	217.9	
	76	THC	–	374.2	372.8	–	358.6	357.3	–	340.9	339.7	–	321.3	320.1	
	76	SHC	–	143.1	191.2	–	138.5	187.1	–	133.3	182.3	–	127.6	176.8	
11,250 Cfm	EAT (wb)	58	THC	285.8	301.5	317.0	273.8	289.0	305.1	259.8	276.1	291.7	244.0	260.9	277.4
		58	SHC	285.8	301.5	317.0	273.8	289.0	305.1	259.8	276.1	291.7	244.0	260.9	277.4
		62	THC	302.2	302.3	317.4	286.3	289.5	305.4	269.6	276.4	288.4	249.3	261.1	277.6
		62	SHC	254.3	300.2	317.4	245.8	289.5	305.4	242.1	276.4	288.4	201.5	261.1	277.6
		67	THC	328.7	327.7	326.7	313.5	312.2	311.1	296.0	294.8	294.3	277.5	275.7	277.9
	67	SHC	197.9	251.1	301.0	192.8	246.4	295.4	187.0	240.4	288.0	160.9	234.6	277.9	
	72	THC	357.4	355.9	354.4	341.8	340.3	339.0	324.4	322.8	321.6	304.8	303.2	302.0	
	72	SHC	140.2	193.9	246.7	135.2	189.4	242.8	129.7	184.3	238.2	123.5	178.4	198.1	
	76	THC	–	379.7	378.2	–	363.9	362.3	–	345.7	344.2	–	327.5	324.0	
	76	SHC	–	147.6	200.8	–	143.1	196.9	–	138.0	192.3	–	132.9	187.1	
12,500 Cfm	EAT (wb)	58	THC	293.7	309.8	325.6	280.3	297.3	313.5	267.0	283.5	299.8	250.8	268.3	284.8
		58	SHC	293.7	309.8	325.6	280.3	297.3	313.5	267.0	283.5	299.8	250.8	268.3	284.8
		62	THC	310.5	310.2	326.1	290.7	297.6	313.9	273.7	283.7	300.1	253.1	268.5	285.0
		62	SHC	264.9	310.1	326.1	262.1	297.6	313.9	255.7	283.7	300.1	246.9	268.5	285.0
		67	THC	333.1	331.7	330.9	317.5	316.2	315.9	299.8	298.7	300.3	280.7	279.6	285.5
	67	SHC	206.6	264.7	317.6	201.9	260.2	311.0	196.2	254.9	300.3	190.0	248.1	285.5	
	72	THC	362.1	360.3	358.7	346.0	344.3	343.0	328.2	326.6	325.1	308.4	306.6	305.3	
	72	SHC	143.6	202.4	260.2	138.7	198.1	256.5	133.2	193.2	252.1	127.1	187.5	246.5	
	76	THC	–	384.3	382.5	–	368.1	366.3	–	349.5	347.8	–	331.0	328.7	
	76	SHC	–	151.9	210.1	–	147.5	206.4	–	142.5	201.9	–	137.4	195.2	

NOTE: See Minimum–Maximum Airflow Ratings in Table 5. Do not operate outside these limits.

LEGEND:

- Do not operate
- Cfm – Cubic feet per minute (supply air)
- EAT(db) – Entering air temperature (dry bulb)
- EAT(wb) – Entering air temperature (wet bulb)
- SHC – Sensible heat capacity
- TC – Total capacity

25 TONS – UNIT WITH HOT GAS REHEAT IN SUBCOOLING MODE										
Temp (F) Air Entering Condenser (Edb)		AIR ENTERING EVAPORATOR – CFM								
		7,500			10,000			12,500		
		Air Entering Evaporator – Ewb (F)								
		72	67	62	72	67	62	72	67	62
75	TC	335.3	305.5	275.8	368.3	334.4	300.5	398.1	360.5	322.9
	SHC	149.6	181.7	213.7	172.8	205.5	238.2	191.7	224.9	258.2
	kW	19.50	18.70	17.70	19.50	18.70	17.70	19.70	18.80	17.90
85	TC	316.3	287.0	257.7	341.5	308.4	275.3	364.3	327.8	291.2
	SHC	120.8	160.5	200.2	144.6	185.2	225.8	164.0	205.4	246.7
	kW	21.90	21.30	20.10	22.30	21.30	20.30	22.50	21.70	20.60
95	TC	297.3	268.5	239.6	314.7	282.4	250.1	330.5	295.0	259.5
	SHC	92.1	139.4	186.7	116.4	164.9	213.5	136.3	185.8	235.3
	kW	24.30	23.50	22.50	24.40	23.50	22.60	24.40	23.60	22.50
105	TC	278.2	249.9	221.6	287.9	256.4	224.9	296.7	262.3	227.8
	SHC	63.3	118.2	173.2	88.3	144.7	201.1	108.7	166.3	223.9
	kW	26.70	26.00	25.00	27.30	26.00	25.00	27.30	26.10	25.10
115	TC	259.2	231.4	203.5	261.1	230.4	199.7	262.9	229.5	196.1
	SHC	34.5	97.1	159.7	60.1	124.4	188.7	81.0	146.7	191.2
	kW	28.70	28.00	27.10	29.30	28.10	26.90	29.10	27.90	27.20

25 TONS – UNIT WITH HOT GAS REHEAT IN HOT GAS REHEAT MODE										
Temp (F) Air Entering Condenser (Edb)		AIR ENTERING EVAPORATOR – Ewb (F)								
		75 Dry Bulb			75 Dry Bulb			75 Dry Bulb		
		62.5 Wet Bulb			64 Wet Bulb			65.3 Wet Bulb		
		(50% Relative)			(56% Relative)			(60% Relative)		
		Air Entering Evaporator – Cfm								
7,500	10,000	12,500	7,500	10,000	12,500	7,500	10,000	12,500		
80	TC	132.40	136.80	148.40	138.20	142.40	154.60	144.30	146.40	162.50
	SHC	37.80	61.50	85.50	21.80	44.40	52.40	16.10	32.10	48.90
	kW	17.90	18.15	18.21	18.05	18.33	18.43	18.26	18.55	18.62
75	TC	138.00	142.20	154.10	143.50	148.00	160.30	148.90	151.00	167.10
	SHC	44.20	68.00	91.80	28.10	51.50	58.80	22.70	38.20	56.00
	kW	17.77	18.00	18.07	17.92	18.19	18.29	18.14	18.40	18.48
70	TC	143.80	148.10	160.00	149.30	154.00	165.90	155.50	157.60	173.80
	SHC	50.50	73.80	98.10	34.20	56.50	65.30	28.30	44.00	62.30
	kW	17.63	17.86	17.93	17.78	18.04	18.14	18.03	18.26	18.34
60	TC	154.80	159.50	171.10	160.20	165.20	177.20	166.70	168.80	185.10
	SHC	63.10	84.50	110.10	46.50	69.50	75.70	41.40	56.50	74.30
	kW	17.35	17.58	17.65	17.50	17.76	17.85	17.70	17.97	18.04
50	TC	166.30	170.50	181.20	171.30	176.40	188.40	178.00	180.00	196.40
	SHC	75.80	96.50	122.20	58.30	79.80	87.80	53.70	69.10	85.90
	kW	17.06	17.30	17.37	17.22	17.46	17.56	17.42	17.69	17.76
40	TC	177.50	181.70	192.30	182.40	187.60	199.70	189.30	191.20	207.70
	SHC	85.70	109.80	134.30	71.50	92.30	100.50	66.10	79.50	97.90
	kW	16.76	17.01	17.09	16.93	17.18	17.28	17.14	17.41	17.47

LEGEND

- Edb** – Entering Dry–Bulb
- Ewb** – Entering Wet–Bulb
- kW** – Compressor Motor Power Input
- ldb** – Leaving Dry–Bulb
- lwb** – Leaving Wet–Bulb
- SHC** – Sensible Heat Capacity (1000 Btuh) Gross
- TC** – Total Capacity (1000 Btuh) Gross

NOTES:

1. Direct interpolation is permissible. Do not extrapolate.
2. The following formulas may be used:

$$t_{ldb} = t_{edb} - \frac{\text{sensible capacity (Btuh)}}{1.10 \times \text{cfm}}$$

t_{lwb} = Wet–bulb temperature corresponding to enthalpy of air leaving evaporator coil (h_{lwb})

$$h_{lwb} = h_{ewb} - \frac{\text{total capacity (Btuh)}}{4.5 \times \text{cfm}}$$

Where: h_{ewb} = Enthalpy of air entering evaporator coil

**Table 16 – STATIC PRESSURE ADDERS (Factory Options and/or Accessories)
Hot Gas Reheat Coil**

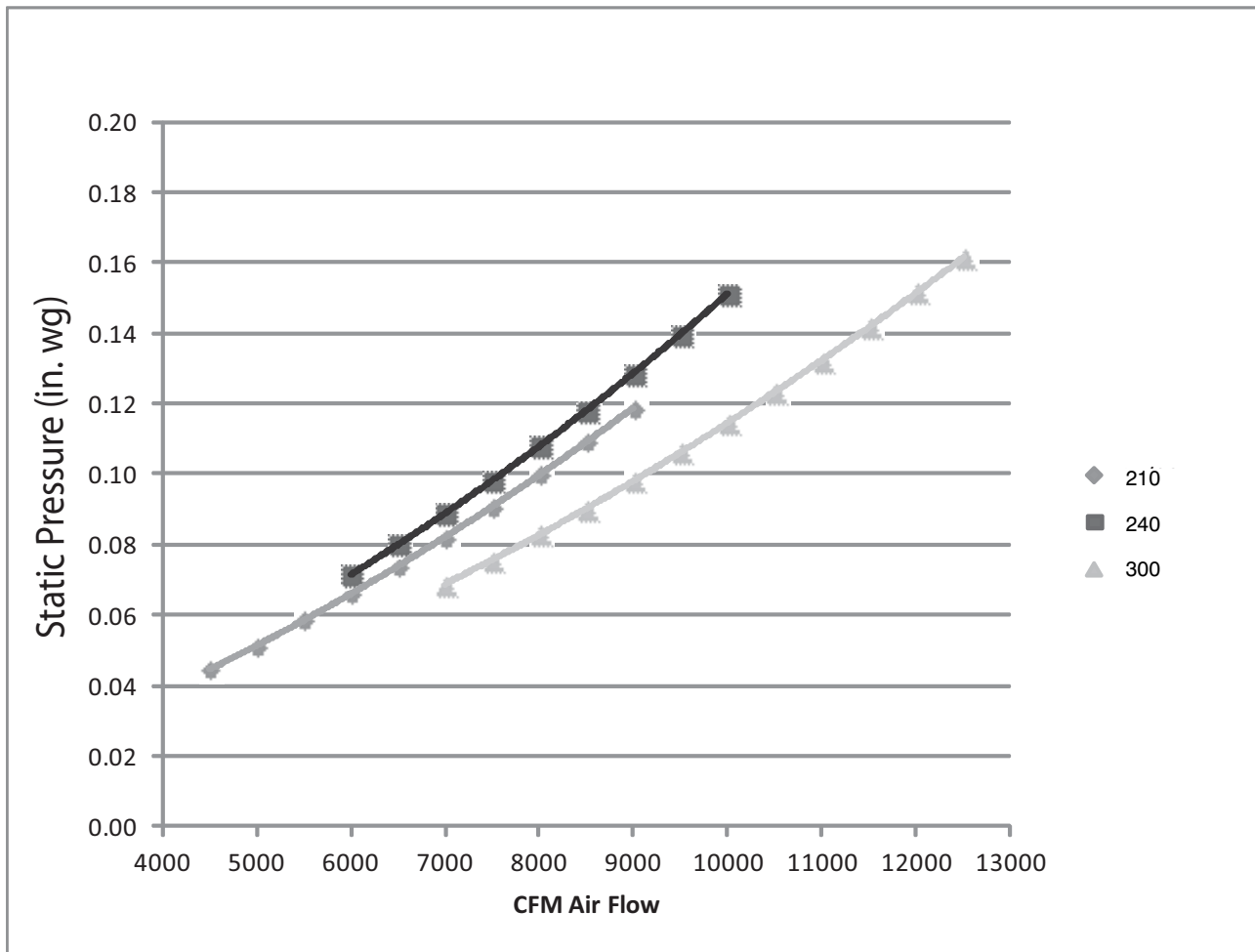

C11175A

Economizer – Vertical Duct Configuration

Model Sizes 210 – 336								
CFM	4500	5000	5500	6000	6500	7000	7500	8000
Vertical	0.047	0.052	0.057	0.062	0.067	0.072	0.077	0.082

Model Sizes 210 – 336									
CFM	8500	9000	9500	10000	10500	11000	11500	12000	12500
Vertical	0.088	0.093	0.098	0.103	0.109	0.114	0.119	0.125	0.131

General fan performance notes:

1. Interpolation is permissible. Do not extrapolate.
2. External static pressure is the static pressure difference between the return duct and the supply duct plus the static pressure caused by any FIOPs or accessories.
3. Tabular data accounts for pressure loss due to clean filters, high gas heat, unit casing, and wet coils. Factory options and accessories may add static pressure losses.
4. The Fan Performance tables offer motor/drive recommendations. In cases when two motor/drive combinations would work, the lower horsepower option is recommended.
5. For information on the electrical properties of motors, please see the Electrical information section of this book.
6. For more information on the performance limits of motors, see the application data section of this book.

FAN PERFORMANCE

Table 17 – RGS210, 17.5 TON

VERTICAL SUPPLY / RETURN

CFM	Available External Static Pressure (in. wg)									
	0.2		0.4		0.6		0.8		1.0	
	RPM	BHP	RPM	BHP	RPM	BHP	RPM	BHP	RPM	BHP
5250	541	1.08	618	1.42	688	1.79	754	2.19	817	2.62
5700	573	1.31	645	1.67	712	2.06	775	2.48	835	2.93
6100	602	1.55	670	1.93	734	2.34	795	2.77	852	3.23
6500	631	1.81	696	2.21	757	2.64	815	3.09	871	3.57
7000	668	2.19	729	2.61	787	3.06	843	3.53	896	4.03
7500	706	2.62	763	3.06	819	3.54	871	4.03	922	4.55
7900	736	3.00	791	3.47	844	3.96	895	4.47	944	5.00
8300	767	3.42	819	3.90	870	4.41	919	4.94	967	5.49
8750	801	3.94	852	4.44	900	4.97	948	5.52	993	6.09

CFM	Available External Static Pressure (in. wg)									
	1.2		1.4		1.6		1.8		2.0	
	RPM	BHP	RPM	BHP	RPM	BHP	RPM	BHP	RPM	BHP
5250	876	3.08	932	3.56	986	4.07	1038	4.60	1088	5.15
5700	892	3.40	946	3.90	998	4.42	1049	4.96	1097	5.52
6100	907	3.72	960	4.23	1011	4.76	1060	5.31	1107	5.89
6500	924	4.07	975	4.59	1025	5.13	1072	5.70	1119	6.28
7000	947	4.55	996	5.09	1044	5.65	1090	6.23	-----	-----
7500	971	5.08	1019	5.64	1064	6.22	-----	-----	-----	-----
7900	992	5.55	1038	6.13	-----	-----	-----	-----	-----	-----
8300	1013	6.06	-----	-----	-----	-----	-----	-----	-----	-----
8750	-----	-----	-----	-----	-----	-----	-----	-----	-----	-----

Std Static Motor and Drive – 622–822 RPM, Max BHP 3.3

Medium Static Motor and Drive – 713–879 RPM, Max BHP 4.9

High Static Motor and Drive – 882–1078 RPM, Max BHP 6.5

----- Outside operating range

Boldface – Field-supplied Drive

Table 18 – RGS240, 20 TON

VERTICAL SUPPLY / RETURN

CFM	Available External Static Pressure (in. wg)									
	0.2		0.4		0.6		0.8		1.0	
	RPM	BHP	RPM	BHP	RPM	BHP	RPM	BHP	RPM	BHP
6000	605	1.48	674	1.77	738	2.08	798	2.41	854	2.74
6500	644	1.82	709	2.14	770	2.47	827	2.81	881	3.17
7000	683	2.22	744	2.56	802	2.91	857	3.28	908	3.65
7500	722	2.68	781	3.04	836	3.41	888	3.80	938	4.19
8000	762	3.20	818	3.58	870	3.97	920	4.38	968	4.79
8500	803	3.78	855	4.19	905	4.60	953	5.02	999	5.46
9000	843	4.43	893	4.86	941	5.30	987	5.74	1032	6.19
9500	884	5.15	932	5.61	978	6.06	1022	6.53	1065	7.01
10000	925	5.95	970	6.43	1015	6.91	1057	7.40	1098	7.89

CFM	Available External Static Pressure (in. wg)									
	1.2		1.4		1.6		1.8		2.0	
	RPM	BHP	RPM	BHP	RPM	BHP	RPM	BHP	RPM	BHP
6000	907	3.10	958	3.46	1006	3.84	1052	4.23	1097	4.63
6500	932	3.54	981	3.92	1027	4.31	1073	4.72	1116	5.14
7000	958	4.04	1005	4.43	1051	4.84	1094	5.27	1137	5.70
7500	985	4.59	1031	5.01	1075	5.44	1118	5.87	1159	6.32
8000	1014	5.21	1058	5.65	1101	6.09	1142	6.55	-----	-----
8500	1044	5.90	1087	6.35	1128	6.82	1168	7.29	-----	-----
9000	1075	6.66	1116	7.13	1156	7.61	-----	-----	-----	-----
9500	1106	7.49	1146	7.98	-----	-----	-----	-----	-----	-----
10000	1139	8.40	-----	-----	-----	-----	-----	-----	-----	-----

Std Static Motor and Drive – 690–863 RPM, Max BHP 4.9

Medium Static Motor and Drive – 835–1021 RPM, Max BHP 6.5

High Static Motor and Drive – 941–1176 RPM, Max BHP 8.7

----- Outside operating range

Boldface – Field-supplied Drive

FAN PERFORMANCE (cont.)

Table 19 – RGS300, 25 TON

VERTICAL SUPPLY / RETURN

CFM	Available External Static Pressure (in. wg)									
	0.2		0.4		0.6		0.8		1.0	
	RPM	BHP	RPM	BHP	RPM	BHP	RPM	BHP	RPM	BHP
7500	713	2.25	778	2.61	838	2.97	894	3.36	946	3.76
8000	752	2.68	814	3.06	871	3.44	925	3.85	976	4.26
8500	791	3.17	850	3.56	905	3.97	957	4.39	1006	4.83
9000	831	3.71	887	4.12	939	4.55	989	4.99	1037	5.45
9500	870	4.31	924	4.75	974	5.19	1023	5.66	1069	6.13
10000	910	4.83	961	5.43	1010	5.90	1057	6.38	1102	6.87
10500	950	5.70	999	6.18	1046	6.67	1091	7.17	1135	7.69
11000	990	6.50	1037	7.01	1083	7.52	1126	8.04	1168	8.57
11500	1030	7.38	1076	7.90	1119	8.43	-----	-----	-----	-----
12000	1070	8.33	-----	-----	-----	-----	-----	-----	-----	-----
12500	-----	-----	-----	-----	-----	-----	-----	-----	-----	-----

CFM	Available External Static Pressure (in. wg)									
	1.2		1.4		1.6		1.8		1.0	
	RPM	BHP	RPM	BHP	RPM	BHP	RPM	BHP	RPM	BHP
7500	996	4.17	1044	4.60	1089	5.05	1133	5.51	1175	5.98
8000	1024	4.70	1071	5.14	1115	5.60	1158	6.07	-----	-----
8500	1053	5.27	1098	5.74	1141	6.21	-----	-----	-----	-----
9000	1083	5.91	1127	6.39	1169	6.88	-----	-----	-----	-----
9500	1113	6.61	1156	7.11	-----	-----	-----	-----	-----	-----
10000	1145	7.38	-----	-----	-----	-----	-----	-----	-----	-----
10500	-----	-----	-----	-----	-----	-----	-----	-----	-----	-----
11000	-----	-----	-----	-----	-----	-----	-----	-----	-----	-----
11500	-----	-----	-----	-----	-----	-----	-----	-----	-----	-----
12000	-----	-----	-----	-----	-----	-----	-----	-----	-----	-----
12500	-----	-----	-----	-----	-----	-----	-----	-----	-----	-----

Std Static Motor and Drive – 717–911 RPM, Max BHP 4.9

Medium Static Motor and Drive – 913–1116 RPM, Max BHP 6.5

High Static Motor and Drive – 941–1176 RPM, Max BHP 8.7

----- Outside operating range

Boldface – Field-supplied Drive

Table 20 – RGS336, 27.5 TON

VERTICAL SUPPLY / RETURN

CFM	Available External Static Pressure (in. wg)									
	0.2		0.4		0.6		0.8		1.0	
	RPM	BHP	RPM	BHP	RPM	BHP	RPM	BHP	RPM	BHP
8250	791	2.86	852	3.28	908	3.72	960	4.16	1010	4.60
8800	836	3.40	893	3.86	947	4.32	998	4.78	1045	5.26
9350	881	4.02	936	4.50	987	4.99	1036	5.48	1082	5.98
9900	926	4.71	979	5.22	1028	5.74	1075	6.26	1120	6.78
10450	972	5.48	1022	6.02	1069	6.56	1115	7.11	1158	7.66
11000	1018	6.33	1066	6.90	1111	7.47	1155	8.04	1197	8.62
11550	1064	7.27	1110	7.86	1154	8.46	1196	9.06	1236	9.66
12100	1110	8.30	1154	8.92	1196	9.54	1237	10.17	1277	10.80
12650	1156	9.42	1199	10.07	1240	10.72	1279	11.38	1317	12.03
13200	1203	10.64	1244	11.32	1283	12.00	1321	12.68	-----	-----
13750	1249	11.97	1289	12.67	-----	-----	-----	-----	-----	-----

CFM	Available External Static Pressure (in. wg)									
	1.2		1.4		1.6		1.8		2.0	
	RPM	BHP	RPM	BHP	RPM	BHP	RPM	BHP	RPM	BHP
8250	1056	5.05	1101	5.51	1144	5.98	1185	6.45	1225	6.93
8800	1091	5.73	1134	6.22	1176	6.71	1216	7.20	1255	7.71
9350	1126	6.48	1168	6.99	1209	7.51	1248	8.03	1286	8.56
9900	1162	7.31	1203	7.84	1243	8.38	1281	8.93	1319	9.48
10450	1199	8.21	1239	8.77	1278	9.34	1315	9.91	1352	10.49
11000	1237	9.20	1276	9.79	1314	10.38	1350	10.97	-----	-----
11550	1276	10.27	1313	10.89	1350	11.50	-----	-----	-----	-----
12100	1315	11.44	1351	12.08	-----	-----	-----	-----	-----	-----
12650	1354	12.70	-----	-----	-----	-----	-----	-----	-----	-----
13200	-----	-----	-----	-----	-----	-----	-----	-----	-----	-----
13750	-----	-----	-----	-----	-----	-----	-----	-----	-----	-----

Std Static Motor and Drive – 751–954 RPM, Max BHP 6.5

Medium Static Motor and Drive – 920–1190 RPM, Max BHP 10.5

High Static Motor & Drive – 1116–1400 RPM, Max BHP 11.9

----- Outside operating range

Boldface – Field-supplied Drive

FAN PERFORMANCE (cont.)

Table 21 – PULLEY ADJUSTMENT – VERTICAL

UNIT	MOTOR/DRIVE COMBO	MOTOR PULLEY TURNS OPEN										
		0	0.5	1	1.5	2	2.5	3	3.5	4	4.5	5
210	Standard Static	822	802	782	762	742	722	702	682	662	642	622
	Medium Static	879	862	846	829	813	796	779	763	746	730	713
	High Static	1078	1058	1039	1019	1000	980	960	941	921	902	882
240	Standard Static	863	846	828	811	794	777	759	742	725	707	690
	Medium Static	1021	1002	984	965	947	928	909	891	872	854	835
	High Static	1176	1153	1129	1106	1082	1059	1035	1012	988	965	941
300	Standard Static	911	892	872	853	833	814	795	775	756	736	717
	Medium Static	1116	1096	1075	1055	1035	1015	994	974	954	933	913
	High Static	1176	1153	1129	1106	1082	1059	1035	1012	988	965	941
336	Standard Static	954	934	913	893	873	853	832	812	792	771	751
	Medium Static	1190	1163	1136	1109	1082	1055	1028	1001	974	947	920
	High Static	1400	1372	1343	1315	1286	1258	1230	1201	1173	1144	1116

NOTE: Do not adjust pulley further than 5 turns open.

■ – Factory settings

DAMPER, BAROMETRIC RELIEF, AND PERFORMANCE, 17.5 to 27.5 Ton

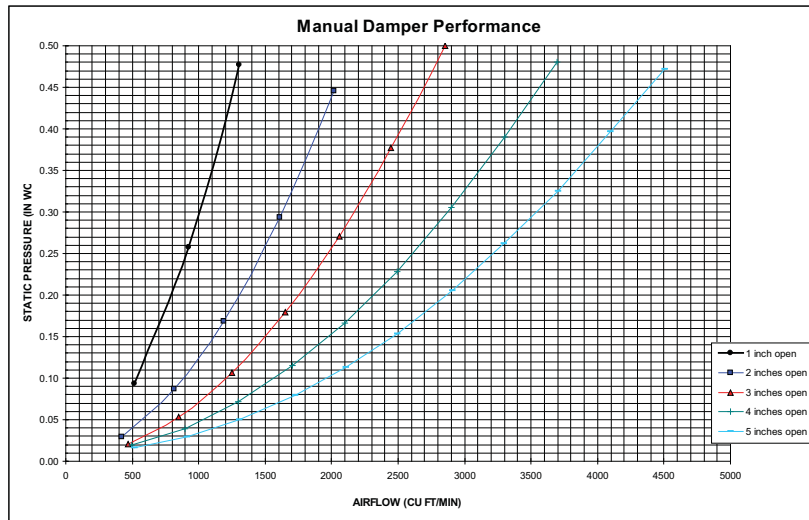

Fig 1 – Manual Damper Performance

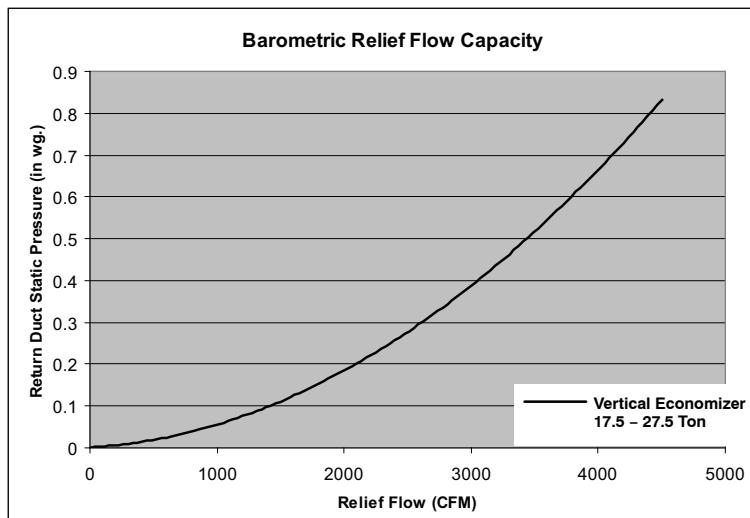

Fig 2 – Barometric Relief Flow Capacity

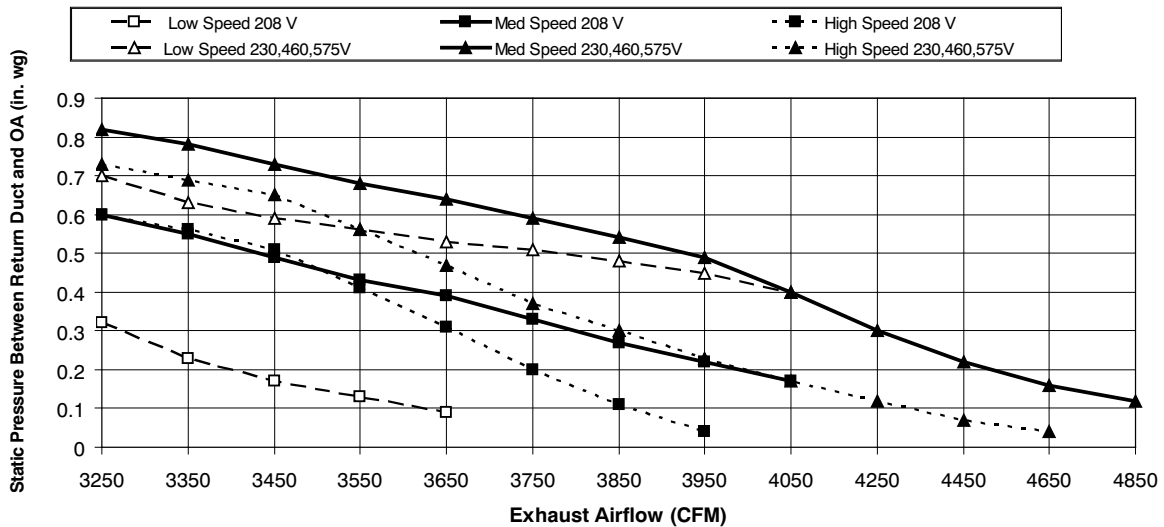

Fig 3 – Power Exhaust Fan Performance

ELECTRICAL DATA FOR UNITS PRODUCED ON OR AFTER JULY 30, 2012

NOTE: Check the serial number of unit to verify production date.

SERIAL NUMBER

1	2	3	4	5	6	7	8	9	10
U	1	2	3	1	1	2	3	4	5

Manufacture Location

Week of Manufacture
(fiscal calendar)

Sequence Number

Year of Manufacture
(12 = 2012)

ELECTRICAL DATA FOR UNITS PRODUCED ON OR AFTER JULY 30, 2012

Table 22 – 2-STAGE COOLING WITH SINGLE SPEED INDOOR FAN MOTOR

Unit RGS	V-Ph-Hz	Voltage Range		Comp 1		Comp 2		OFM (ea)		IFM		
		MIN	MAX	RLA	LRA	RLA	LRA	WATTS	FLA	TYPE	Full Load Efficiency	FLA
210	208-3-60	187	253	29.5	195	30.1	225	350	1.5	STD	87.0%	10.6
										MED	82.9%	13.6
										HIGH	89.5%	17.1
	230-3-60	187	253	29.5	195	30.1	225	350	1.5	STD	87.0%	10.6
										MED	82.9%	12.7
										HIGH	89.5%	17.1
	460-3-60	414	506	14.7	95	16.7	114	277	0.9	STD	87.0%	5.3
										MED	82.9%	6.4
										HIGH	89.5%	8.6
	575-3-60	518	633	12.2	80	12.2	80	397	0.6	STD	81.1%	2.8
										MED	83.6%	5.6
										HIGH	89.5%	7.6
240	208-3-60	187	253	48.1	245	29.5	195	350	1.5	STD	82.9%	13.6
										MED	89.5%	17.1
										HIGH	91.7%	28.5
	230-3-60	187	253	48.1	245	29.5	195	350	1.5	STD	82.9%	12.7
										MED	89.5%	17.1
										HIGH	91.7%	28.5
	460-3-60	414	506	18.6	125	14.7	95	277	0.9	STD	82.9%	6.4
										MED	89.5%	8.6
										HIGH	91.7%	14.3
	575-3-60	518	633	14.7	100	12.2	80	397	0.6	STD	83.6%	5.6
										MED	89.5%	7.6
										HIGH	91.7%	14.3
300	208-3-60	187	253	48.1	245	48.1	245	350	1.5	STD	82.9%	13.6
										MED	89.5%	17.1
										HIGH	91.7%	28.5
	230-3-60	187	253	48.1	245	48.1	245	350	1.5	STD	82.9%	12.7
										MED	89.5%	17.1
										HIGH	91.7%	28.5
	460-3-60	414	506	18.6	125	18.6	125	277	0.9	STD	82.9%	6.4
										MED	89.5%	8.6
										HIGH	91.7%	14.3
	575-3-60	518	633	14.7	100	14.7	100	397	0.6	STD	83.6%	5.6
										MED	89.5%	7.6
										HIGH	91.7%	9.5
336	208-3-60	187	253	51.3	300	51.3	300	350	1.5	STD	89.5%	17.1
										MED	91.7%	28.5
										HIGH	91.7%	30.4
	230-3-60	187	253	51.3	300	51.3	300	350	1.5	STD	89.5%	17.1
										MED	91.7%	28.5
										HIGH	91.7%	30.4
	460-3-60	414	506	23.1	150	23.1	150	277	0.9	STD	89.5%	8.6
										MED	91.7%	14.3
										HIGH	91.7%	15.2
	575-3-60	518	633	19.9	109	19.9	109	397	0.6	STD	89.5%	7.6
										MED	91.7%	9.5
										HIGH	91.7%	12.4

See: "Legend and Notes" for Tables 22 thru 25 on page 44.

ELECTRICAL DATA FOR UNITS PRODUCED ON OR AFTER JULY 30, 2012

Table 23 – 2-STAGE COOLING WITH 2 SPEED INDOOR FAN MOTOR

UNIT RGS	V-Ph-Hz	VOLTAGE RANGE		COMP 1		COMP 2		OFM (ea)		IFM		
		MIN	MAX	RLA	LRA	RLA	LRA	WATTS	FLA	TYPE	EFF at Full Load	FLA
210	208-3-60	187	253	29.5	195	30.1	225	350	1.5	STD	81.5%	10.8
										MED	83.6%	13.6
										HIGH	89.5%	17.1
	230-3-60	187	253	29.5	195	30.1	225	350	1.5	STD	81.5%	9.8
										MED	83.6%	12.7
										HIGH	89.5%	17.1
	460-3-60	414	506	14.7	95	16.7	114	277	0.9	STD	81.5%	4.9
										MED	83.6%	6.4
										HIGH	89.5%	8.6
	575-3-60	518	633	12.2	80	12.2	80	397	0.6	STD	81.1%	4.5
										MED	83.6%	6.2
										HIGH	89.5%	7.6
240	208-3-60	187	253	48.1	245	29.5	195	350	1.5	STD	83.6%	13.6
										MED	89.5%	17.1
										HIGH	91.7%	28.5
	230-3-60	187	253	48.1	245	29.5	195	350	1.5	STD	83.6%	12.7
										MED	89.5%	17.1
										HIGH	91.7%	28.5
	460-3-60	414	506	18.6	125	14.7	95	277	0.9	STD	83.6%	6.4
										MED	89.5%	8.6
										HIGH	91.7%	14.3
	575-3-60	518	633	14.7	100	12.2	80	397	0.6	STD	83.6%	6.2
										MED	89.5%	7.6
										HIGH	91.7%	9.5
300	208-3-60	187	253	48.1	245	48.1	245	350	1.5	STD	83.6%	13.6
										MED	89.5%	17.1
										HIGH	91.7%	28.5
	230-3-60	187	253	48.1	245	48.1	245	350	1.5	STD	83.6%	12.7
										MED	89.5%	17.1
										HIGH	91.7%	28.5
	460-3-60	414	506	18.6	125	18.6	125	277	0.9	STD	83.6%	6.4
										MED	89.5%	8.6
										HIGH	91.7%	14.3
	575-3-60	518	633	14.7	100	14.7	100	397	0.6	STD	83.6%	6.2
										MED	89.5%	7.6
										HIGH	91.7%	9.5
336	208-3-60	187	253	51.3	300	51.3	300	350	1.5	STD	89.5%	17.1
										MED	91.7%	28.5
										HIGH	91.7%	30.4
	230-3-60	187	253	51.3	300	51.3	300	350	1.5	STD	89.5%	17.1
										MED	91.7%	28.5
										HIGH	91.7%	30.4
	460-3-60	414	506	23.1	150	23.1	150	277	0.9	STD	89.5%	8.6
										MED	91.7%	14.3
										HIGH	91.7%	15.2
	575-3-60	518	633	19.9	109	19.9	109	397	0.6	STD	89.5%	7.6
										MED	91.7%	9.5
										HIGH	91.7%	12.4

See: "Legend and Notes" for Tables 22 thru 25 on page 44.

ELECTRICAL DATA FOR UNITS PRODUCED ON OR AFTER JULY 30, 2012

Table 24 – UNIT WIRE/FUSE OR HACR BREAKER SIZING DATA WITH SINGLE SPEED INDOOR FAN MOTOR

UNIT RGS	NOM. V–Ph–Hz	IFM TYPE	NO C.O. or UNPWR C.O.							
			NO P.E.				w/ P.E. (pwrd fr/ unit)			
			MCA	MAX FUSE or HACR BRKR	DISC. SIZE		MCA	MAX FUSE or HACR BRKR	DISC. SIZE	
					FLA	LRA			FLA	LRA
210	208/230–3–60	STD	82.2	100	86	515	94.0	110	99	535
		MED	85.2/84.3	100/100	89/88	517	97.0/96.1	125/125	103/102	537
		HIGH	88.7	100	93	513	100.5	125	107	533
	460–3–60	STD	43.6	60	45	258	49.8	60	52	270
		MED	44.7	60	47	259	50.9	60	54	271
		HIGH	46.9	60	49	257	53.1	60	56	269
	575–3–60	STD	32.1	40	33	188	36.9	45	39	196
		MED	34.9	45	37	202	39.7	50	42	210
		HIGH	36.9	45	39	200	41.7	50	44	208
240	208/230–3–60	STD	109.2/108.3	150/150	112/111	540	121.0/120.1	150/150	125/124	560
		MED	112.7	150	116	536	124.5	150	129	556
		HIGH	124.1	150	129	615	135.9	175	142	635
	460–3–60	STD	48.0	60	50	272	54.2	60	57	284
		MED	50.2	60	52	270	56.4	70	59	282
		HIGH	55.9	70	59	310	62.1	80	66	322
	575–3–60	STD	38.6	50	40	224	43.4	50	46	232
		MED	40.6	50	42	222	45.4	60	48	230
		HIGH	42.5	50	45	249	47.3	60	50	257
300	208/230–3–60	STD	127.8/126.9	175/175	133/132	590	139.6/138.7	175/175	147/146	610
		MED	131.3	175	137	586	143.1	175	151	606
		HIGH	142.7	175	150	665	154.5	200	164	685
	460–3–60	STD	51.9	60	54	302	58.1	70	61	314
		MED	54.1	60	57	300	60.3	70	64	312
		HIGH	59.8	70	63	340	66.0	80	70	352
	575–3–60	STD	41.1	50	43	244	45.9	60	49	252
		MED	43.1	50	45	242	47.9	60	51	250
		HIGH	45.0	50	47	269	49.8	60	53	277
336	208/230–3–60	STD	141.5	175	148	702	153.3	200	162	722
		MED	152.9	200	161	781	164.7	200	175	801
		HIGH	154.8	200	163	812	166.6	200	177	832
	460–3–60	STD	66.0	80	69	354	72.2	90	76	366
		MED	71.7	90	76	394	77.9	100	83	406
		HIGH	72.6	90	77	409	78.8	100	84	421
	575–3–60	STD	56.0	70	59	264	60.8	80	64	272
		MED	57.9	70	61	291	62.7	80	66	299
		HIGH	60.8	80	64	302	65.6	80	70	310

See: "Legend and Notes" for Tables 22 thru 25 on page 44.

ELECTRICAL DATA FOR UNITS PRODUCED ON OR AFTER JULY 30, 2012

Table 25 – UNIT WIRE/FUSE OR HACR BREAKER SIZING DATA WITH 2 SPEED INDOOR FAN MOTOR

UNIT RGS	NOM. V–Ph–Hz	IFM TYPE	NO C.O. or UNPWR C.O.							
			NO P.E.				w/ P.E. (pwrd fr/ unit)			
			MCA	MAX FUSE or HACR BRKR	DISC. SIZE		MCA	MAX FUSE or HACR BRKR	DISC. SIZE	
					FLA	LRA			FLA	LRA
210	208/230–3–60	STD	82.4/81.4	100/100	86/85	506	94.2/93.2	110/110	100/99	526
		MED	85.2/84.3	100/100	89/88	517	97.0/96.1	125/125	103/102	537
		HIGH	88.7	100	93	513	100.5	125	107	533
	460–3–60	STD	43.2	50	45	254	49.4	60	52	266
		MED	44.7	60	47	259	50.9	60	54	271
		HIGH	46.9	60	49	257	53.1	60	56	269
	575–3–60	STD	33.8	45	35	188	38.6	50	41	196
		MED	35.5	45	37	202	40.3	50	43	210
		HIGH	36.9	45	39	200	41.7	50	44	208
240	208/230–3–60	STD	109.2/108.3	150/150	112/111	540	121.0/120.1	150/150	125/124	560
		MED	112.7	150	116	536	124.5	150	129	556
		HIGH	124.1	150	129	615	135.9	175	142	635
	460–3–60	STD	48.0	60	50	272	54.2	60	57	284
		MED	50.2	60	52	270	56.4	70	59	282
		HIGH	55.9	70	59	310	62.1	80	66	322
	575–3–60	STD	39.2	50	41	224	44.0	50	46	232
		MED	40.6	50	42	222	45.4	60	48	230
		HIGH	42.5	50	45	249	47.3	60	50	257
300	208/230–3–60	STD	127.8/126.9	175/175	133/132	590	139.6/138.7	175/175	147/146	610
		MED	131.3	175	137	586	143.1	175	151	606
		HIGH	142.7	175	150	665	154.5	200	164	685
	460–3–60	STD	51.9	60	54	302	58.1	70	61	314
		MED	54.1	60	57	300	60.3	70	64	312
		HIGH	59.8	70	63	340	66.0	80	70	352
	575–3–60	STD	41.7	50	44	244	46.5	60	49	252
		MED	43.1	50	45	242	47.9	60	51	250
		HIGH	45	50	47	269	49.8	60	53	277
336	208/230–3–60	STD	141.5	175	148	702	153.3	200	162	722
		MED	152.9	200	161	781	164.7	200	175	801
		HIGH	154.8	200	163	812	166.6	200	177	832
	460–3–60	STD	66.0	80	69	354	72.2	90	76	366
		MED	71.7	90	76	394	77.9	100	83	406
		HIGH	72.6	90	77	409	78.8	100	84	421
	575–3–60	STD	56.0	70	59	264	60.8	80	64	272
		MED	57.9	70	61	291	62.7	80	66	299
		HIGH	60.8	80	64	302	65.6	80	70	310

See: "Legend and Notes" for Tables 22 thru 25 on page 44.

Legend and Notes for Tables 22–25

LEGEND:

BRKR	–	Circuit Breaker
C.O.	–	Convenient outlet
DISC	–	Disconnect
FLA	–	Full load amps
IFM	–	Indoor fan motor
LRA	–	Locked rotor amps
MCA	–	Minimum circuit amps
MOCP	–	Maximum over current protection
P.E.	–	Power exhaust
UNPWRD CO	–	Unpowered convenient outlet



NOTES:

1. IN COMPLIANCE WITH NEC REQUIREMENTS FOR MULTIMOTOR AND COMBINATION LOAD EQUIPMENT (REFER TO NEC ARTICLES 430 AND 440), THE OVERCURRENT PROTECTIVE DEVICE FOR THE UNIT SHALL BE FUSE OR HACR BREAKER. CANADIAN UNITS MAY BE FUSE OR CIRCUIT BREAKER.
2. UNBALANCED 3-PHASE SUPPLY VOLTAGE
NEVER OPERATE A MOTOR WHERE A PHASE IMBALANCE IN SUPPLY VOLTAGE IS GREATER THAN 2%. USE THE FOLLOWING FORMULA TO DETERMINE THE PERCENTAGE OF VOLTAGE IMBALANCE.

$$\% \text{ Voltage Imbalance} = 100 \times \frac{\text{max voltage deviation from average voltage}}{\text{average voltage}}$$

Example: Supply voltage is 230-3-60



AB = 224 v
BC = 231 v
AC = 226 v

$$\text{Average Voltage} = \frac{(224 + 231 + 226)}{3} = \frac{681}{3} = 227$$

Determine maximum deviation from average voltage.

$$(AB) 227 - 224 = 3 \text{ v}$$

$$(BC) 231 - 227 = 4 \text{ v}$$

$$(AC) 227 - 226 = 1 \text{ v}$$

Maximum deviation is 4 v.

Determine percent of voltage imbalance.

$$\% \text{ Voltage Imbalance} = 100 \times \frac{4}{227} = 1.76\%$$

This amount of phase imbalance is satisfactory as it is below the maximum allowable 2%.

IMPORTANT: If the supply voltage phase imbalance is more than 2%, contact your local electric utility company immediately.

ELECTRICAL DATA FOR UNITS PRODUCED PRIOR TO JULY 30, 2012

NOTE: Check the serial number of unit to verify production date.

SERIAL NUMBER

1	2	3	4	5	6	7	8	9	10
U	1	2	3	1	1	2	3	4	5

Manufacture Location

Week of Manufacture
(fiscal calendar)

Sequence Number

Year of Manufacture
(12 = 2012)

ELECTRICAL DATA FOR UNITS PRODUCED PRIOR TO JULY 30, 2012

Table 26 – 2-STAGE COOLING WITH SINGLE SPEED INDOOR FAN MOTOR

UNIT RGS	V-Ph-Hz	VOLTAGE RANGE		COMP 1		COMP 2		OFM (ea)		IFM		
		MIN	MAX	RLA	LRA	RLA	LRA	WATTS	FLA	TYPE	EFF at Full Load	FLA
210	208-3-60	187	253	29.5	195	30.1	225	350	1.5	STD	83.8%	10.2
										MED	83.6%	15.0
										HIGH	89.5%	17.1
	230-3-60	187	253	29.5	195	30.1	225	350	1.5	STD	83.8%	10.2
										MED	83.6%	15.0
										HIGH	89.5%	17.1
	460-3-60	414	506	14.7	95	16.7	114	277	0.9	STD	83.8%	4.8
										MED	83.6%	7.4
										HIGH	89.5%	8.6
	575-3-60	518	633	12.2	80	12.2	80	397	0.6	STD	81.1%	2.8
										MED	83.6%	5.6
										HIGH	89.5%	7.6
240	208-3-60	187	253	48.1	245	29.5	195	350	1.5	STD	83.6%	15.0
										MED	89.5%	17.1
										HIGH	91.7%	28.5
	230-3-60	187	253	48.1	245	29.5	195	350	1.5	STD	83.6%	15.0
										MED	89.5%	17.1
										HIGH	91.7%	28.5
	460-3-60	414	506	18.6	125	14.7	95	277	0.9	STD	83.6%	7.4
										MED	89.5%	8.6
										HIGH	91.7%	14.3
	575-3-60	518	633	14.7	100	12.2	80	397	0.6	STD	83.6%	5.6
										MED	89.5%	7.6
										HIGH	91.7%	9.5
300	208-3-60	187	253	48.1	245	48.1	245	350	1.5	STD	83.6%	15.0
										MED	89.5%	17.1
										HIGH	91.7%	28.5
	230-3-60	187	253	48.1	245	48.1	245	350	1.5	STD	83.6%	15.0
										MED	89.5%	17.1
										HIGH	91.7%	28.5
	460-3-60	414	506	18.6	125	18.6	125	277	0.9	STD	83.6%	7.4
										MED	89.5%	8.6
										HIGH	91.7%	14.3
	575-3-60	518	633	14.7	100	14.7	100	397	0.6	STD	83.6%	5.6
										MED	89.5%	7.6
										HIGH	91.7%	9.5
336	208-3-60	187	253	51.3	300	51.3	300	350	1.5	STD	89.5%	17.1
										MED	91.7%	28.5
										HIGH	91.7%	30.4
	230-3-60	187	253	51.3	300	51.3	300	350	1.5	STD	89.5%	17.1
										MED	91.7%	28.5
										HIGH	91.7%	30.4
	460-3-60	414	506	23.1	150	23.1	150	277	0.9	STD	89.5%	8.6
										MED	91.7%	14.3
										HIGH	91.7%	15.2
	575-3-60	518	633	19.9	109	19.9	109	397	0.6	STD	89.5%	7.6
										MED	91.7%	9.5
										HIGH	91.7%	12.4

See: "Legend and Notes" for Tables 26 thru 29 on page 50.

ELECTRICAL DATA FOR UNITS PRODUCED PRIOR TO JULY 30, 2012

Table 27 – 2-STAGE COOLING WITH 2 SPEED INDOOR FAN MOTOR

UNIT RGS	V-Ph-Hz	VOLTAGE RANGE		COMP 1		COMP 2		OFM (ea)		IFM		
		MIN	MAX	RLA	LRA	RLA	LRA	WATTS	FLA	TYPE	EFF at Full Load	FLA
210	208-3-60	187	253	29.5	195	30.1	225	350	1.5	STD	81.5%	10.8
										MED	83.6%	13.6
										HIGH	89.5%	17.1
	230-3-60	187	253	29.5	195	30.1	225	350	1.5	STD	81.5%	9.8
										MED	83.6%	12.7
										HIGH	89.5%	17.1
	460-3-60	414	506	14.7	95	16.7	114	277	0.9	STD	81.5%	4.9
										MED	83.6%	6.4
										HIGH	89.5%	8.6
	575-3-60	518	633	12.2	80	12.2	80	397	0.6	STD	81.1%	4.5
										MED	83.6%	6.2
										HIGH	89.5%	7.6
240	208-3-60	187	253	48.1	245	29.5	195	350	1.5	STD	83.6%	13.6
										MED	89.5%	17.1
										HIGH	91.7%	28.5
	230-3-60	187	253	48.1	245	29.5	195	350	1.5	STD	83.6%	12.7
										MED	89.5%	17.1
										HIGH	91.7%	28.5
	460-3-60	414	506	18.6	125	14.7	95	277	0.9	STD	83.6%	6.4
										MED	89.5%	8.6
										HIGH	91.7%	14.3
	575-3-60	518	633	14.7	100	12.2	80	397	0.6	STD	83.6%	6.2
										MED	89.5%	7.6
										HIGH	91.7%	9.5
300	208-3-60	187	253	48.1	245	48.1	245	350	1.5	STD	83.6%	13.6
										MED	89.5%	17.1
										HIGH	91.7%	28.5
	230-3-60	187	253	48.1	245	48.1	245	350	1.5	STD	83.6%	12.7
										MED	89.5%	17.1
										HIGH	91.7%	28.5
	460-3-60	414	506	18.6	125	18.6	125	277	0.9	STD	83.6%	6.4
										MED	89.5%	8.6
										HIGH	91.7%	14.3
	575-3-60	518	633	14.7	100	14.7	100	397	0.6	STD	83.6%	6.2
										MED	89.5%	7.6
										HIGH	91.7%	9.5
336	208-3-60	187	253	51.3	300	51.3	300	350	1.5	STD	89.5%	17.1
										MED	91.7%	28.5
										HIGH	91.7%	30.4
	230-3-60	187	253	51.3	300	51.3	300	350	1.5	STD	89.5%	17.1
										MED	91.7%	28.5
										HIGH	91.7%	30.4
	460-3-60	414	506	23.1	150	23.1	150	277	0.9	STD	89.5%	8.6
										MED	91.7%	14.3
										HIGH	91.7%	15.2
	575-3-60	518	633	19.9	109	19.9	109	397	0.6	STD	89.5%	7.6
										MED	91.7%	9.5
										HIGH	91.7%	12.4

See: "Legend and Notes" for Tables 26 thru 29 on page 50.

ELECTRICAL DATA FOR UNITS PRODUCED PRIOR TO JULY 30, 2012

Table 28 – UNIT WIRE/FUSE OR HACR BREAKER SIZING DATA WITH SINGLE SPEED INDOOR FAN MOTOR

UNIT RGS	NOM. V–Ph–Hz	IFM TYPE	NO C.O. or UNPWR C.O.							
			NO P.E.				w/ P.E. (pwrd fr/ unit)			
			MCA	MAX FUSE or HACR BRKR	DISC. SIZE		MCA	MAX FUSE or HACR BRKR	DISC. SIZE	
					FLA	LRA			FLA	LRA
210	208/230–3–60	STD	82.2	100	86	515	94.0	110	99	535
		MED	85.2/84.3	100/100	89/88	517	97.0/96.1	125/125	103/102	537
		HIGH - High Efficiency	88.7	100	93	513	100.5	125	107	533
	460–3–60	STD	43.6	60	45	258	49.8	60	52	270
		MED	44.7	60	47	259	50.9	60	54	271
		HIGH - High Efficiency	46.9	60	49	257	53.1	60	56	269
	575–3–60	STD	32.1	40	33	188	36.9	45	39	196
		MED	34.9	45	37	202	39.7	50	42	210
		HIGH - High Efficiency	36.9	45	39	200	41.7	50	44	208
240	208/230–3–60	STD	109.2/108.3	150/150	112/111	540	121.0/120.1	150/150	125/124	560
		MED - High Efficiency	112.7	150	116	536	124.5	150	129	556
		HIGH - High Efficiency	124.1	150	129	615	135.9	175	142	635
	460–3–60	STD	48.0	60	50	272	54.2	60	57	284
		MED - High Efficiency	50.2	60	52	270	56.4	70	59	282
		HIGH - High Efficiency	55.9	70	59	310	62.1	80	66	322
	575–3–60	STD	38.6	50	40	224	43.4	50	46	232
		MED - High Efficiency	40.6	50	42	222	45.4	60	48	230
		HIGH - High Efficiency	42.5	50	45	249	47.3	60	50	257
300	208/230–3–60	STD	127.8/126.9	175/175	133/132	590	139.6/138.7	175/175	147/146	610
		MED- High Efficiency	131.3	175	137	586	143.1	175	151	606
		HIGH- High Efficiency	142.7	175	150	665	154.5	200	164	685
	460–3–60	STD	51.9	60	54	302	58.1	70	61	314
		MED- High Efficiency	54.1	60	57	300	60.3	70	64	312
		HIGH- High Efficiency	59.8	70	63	340	66.0	80	70	352
	575–3–60	STD	41.1	50	43	244	45.9	60	49	252
		MED- High Efficiency	43.1	50	45	242	47.9	60	51	250
		HIGH- High Efficiency	45.0	50	47	269	49.8	60	53	277
336	208/230–3–60	STD	141.5	175	148	702	153.3	200	162	722
		MED- High Efficiency	152.9	200	161	781	164.7	200	175	801
		HIGH- High Efficiency	154.8	200	163	812	166.6	200	177	832
	460–3–60	STD	66.0	80	69	354	72.2	90	76	366
		MED- High Efficiency	71.7	90	76	394	77.9	100	83	406
		HIGH- High Efficiency	72.6	90	77	409	78.8	100	84	421
	575–3–60	STD	56.0	70	59	264	60.8	80	64	272
		MED- High Efficiency	57.9	70	61	291	62.7	80	66	299
		HIGH- High Efficiency	60.8	80	64	302	65.6	80	70	310

ELECTRICAL DATA FOR UNITS PRODUCED PRIOR TO JULY 30, 2012

Table 29 – UNIT WIRE/FUSE OR HACR BREAKER SIZING DATA WITH 2 SPEED INDOOR FAN MOTOR

UNIT RGS	NOM. V–Ph–Hz	IFM TYPE	NO C.O. or UNPWR C.O.							
			NO P.E.				w/ P.E. (pwrd fr/ unit)			
			MCA	MAX FUSE or HACR BRKR	DISC. SIZE		MCA	MAX FUSE or HACR BRKR	DISC. SIZE	
					FLA	LRA			FLA	LRA
210	208/230–3–60	STD	82.4/81.4	100/100	86/85	506	94.2/93.2	110/110	100/99	526
		MED	85.2/84.3	100/100	89/88	517	97.0/96.1	125/125	103/102	537
		HIGH	88.7	100	93	513	100.5	125	107	533
	460–3–60	STD	43.2	50	45	254	49.4	60	52	266
		MED	44.7	60	47	259	50.9	60	54	271
		HIGH	46.9	60	49	257	53.1	60	56	269
	575–3–60	STD	33.8	45	35	188	38.6	50	41	196
		MED	35.5	45	37	202	40.3	50	43	210
		HIGH	36.9	45	39	200	41.7	50	44	208
240	208/230–3–60	STD	109.2/108.3	150/150	112/111	540	121.0/120.1	150/150	125/124	560
		MED	112.7	150	116	536	124.5	150	129	556
		HIGH	124.1	150	129	615	135.9	175	142	635
	460–3–60	STD	48.0	60	50	272	54.2	60	57	284
		MED	50.2	60	52	270	56.4	70	59	282
		HIGH	55.9	70	59	310	62.1	80	66	322
	575–3–60	STD	39.2	50	41	224	44.0	50	46	232
		MED	40.6	50	42	222	45.4	60	48	230
		HIGH	42.5	50	45	249	47.3	60	50	257
300	208/230–3–60	STD	127.8/126.9	175/175	133/132	590	139.6/138.7	175/175	147/146	610
		MED	131.3	175	137	586	143.1	175	151	606
		HIGH	142.7	175	150	665	154.5	200	164	685
	460–3–60	STD	51.9	60	54	302	58.1	70	61	314
		MED	54.1	60	57	300	60.3	70	64	312
		HIGH	59.8	70	63	340	66.0	80	70	352
	575–3–60	STD	41.7	50	44	244	46.5	60	49	252
		MED	43.1	50	45	242	47.9	60	51	250
		HIGH	45	50	47	269	49.8	60	53	277
336	208/230–3–60	STD	141.5	175	148	702	153.3	200	162	722
		MED	152.9	200	161	781	164.7	200	175	801
		HIGH	154.8	200	163	812	166.6	200	177	832
	460–3–60	STD	66.0	80	69	354	72.2	90	76	366
		MED	71.7	90	76	394	77.9	100	83	406
		HIGH	72.6	90	77	409	78.8	100	84	421
	575–3–60	STD	56.0	70	59	264	60.8	80	64	272
		MED	57.9	70	61	291	62.7	80	66	299
		HIGH	60.8	80	64	302	65.6	80	70	310

See: "Legend and Notes" for Tables 26 thru 29 on page 50.

Legend and Notes for Tables 26 – 29

LEGEND:

C.O.	– Convenient outlet
DISC	– Disconnect
FLA	– Full load amps
IFM	– Indoor fan motor
LRA	– Locked rotor amps
MCA	– Minimum circuit amps
MOCP	– Maximum over current protection
PE.	– Power exhaust
UNPWRD CO	– Unpowered convenient outlet
BRKR	– Circuit Breaker



NOTES:

1. IN COMPLIANCE WITH NEC REQUIREMENTS FOR MULTIMOTOR AND COMBINATION LOAD EQUIPMENT (REFER TO NEC ARTICLES 430 AND 440), THE OVERCURRENT PROTECTIVE DEVICE FOR THE UNIT SHALL BE FUSE OR HACR BREAKER. CANADIAN UNITS MAY BE FUSE OR CIRCUIT BREAKER.

2. UNBALANCED 3-PHASE SUPPLY VOLTAGE

NEVER OPERATE A MOTOR WHERE A PHASE IMBALANCE IN SUPPLY VOLTAGE IS GREATER THAN 2%. USE THE FOLLOWING FORMULA TO DETERMINE THE PERCENTAGE OF VOLTAGE IMBALANCE.

$$\% \text{ Voltage Imbalance} = 100 \times \frac{\text{max voltage deviation from average voltage}}{\text{average voltage}}$$

Example: Supply voltage is 230-3-60



AB = 224 v
BC = 231 v
AC = 226 v

$$\begin{aligned} \text{Average Voltage} &= \frac{(224 + 231 + 226)}{3} = \frac{681}{3} \\ &= 227 \end{aligned}$$

Determine maximum deviation from average voltage.

$$(AB) 227 - 224 = 3 \text{ v}$$

$$(BC) 231 - 227 = 4 \text{ v}$$

$$(AC) 227 - 226 = 1 \text{ v}$$

Maximum deviation is 4 v.

Determine percent of voltage imbalance.

$$\begin{aligned} \% \text{ Voltage Imbalance} &= 100 \times \frac{4}{227} \\ &= 1.76\% \end{aligned}$$

This amount of phase imbalance is satisfactory as it is below the maximum allowable 2%.

IMPORTANT: If the supply voltage phase imbalance is more than 2%, contact your local electric utility company immediately.

SEQUENCE OF OPERATION

General

The sequence below describes the sequence of operation for an electro-mechanical unit with and without a factory installed Economizer IV and X (called “economizer” in this sequence).

Units with no economizer

Cooling —

When the field supplied commercial grade thermostat calls for cooling, terminals G and Y1 are energized. As a result, the indoor-fan contactor (IFC) and the compressor contactor (C1) are energized, causing the indoor-fan motor (IFM), compressor #1, and outdoor fan to start. If the unit has 2 stages of cooling, the thermostat will additionally energize Y2. The Y2 signal will energize compressor contactor #2 (C2), causing compressor #2 to start. Regardless of the number of stages, the outdoor-fan motor runs continuously while unit is cooling.

Heating —

NOTE: Units have 2 stages of gas heat.

When the field supplied commercial grade thermostat calls for heating, power is sent to W on the Integrated Gas Controller (IGC) board. An LED (light-emitting diode) on the IGC board turns on and remains on during normal operation. A check is made to ensure that the rollout switch and limit switch are closed. If the check was successful, the induced-draft motor is energized, and when its speed is satisfactory, as proven by the “hall effect” sensor, the ignition activation period begins. The burners will ignite within 5 seconds. If the burners do not light, there is a 22-second delay before another 5-second attempt. This sequence is repeated for 15 minutes or until the burners light. If, after the 15 minutes, the burners still have not lit, heating is locked out. To reset the control, break 24-v power to the thermostat.

When ignition occurs, the IGC board will continue to monitor the condition of the rollout switch, the limit switches, the “hall effect” sensor, as well as the flame sensor. 45 seconds after ignition occurs, assuming the unit is controlled through a room thermostat set for fan auto, the indoor-fan motor will energize (and the outdoor-air dampers will open to their minimum position). If, for some reason, the over-temperature limit opens prior to the start of the indoor fan blower, the unit will shorten the 45-second delay to 5 seconds less than the time from initiation of heat to when the limit tripped. Gas will not be interrupted to the burners and heating will continue. Once the fan-on delay has been modified, it will not change back to 45 seconds until power is reset to the control.

On units with 2 stages of heat, when additional heat is required, W2 closes and initiates power to the second stage of the main gas valve. When the thermostat is satisfied, W1 and W2 open and the gas valve closes, interrupting the flow of gas to the main burners.

If the call for W1 lasted less than 1 minute, the heating cycle will not terminate until 1 minute after W1 became active. If the unit is controlled through a room thermostat set for fan auto, the indoor-fan motor will continue to operate for an additional 45 seconds then stop. If the over-temperature limit opens after the indoor motor is stopped, but within 10 minutes of W1 becoming inactive, on the next cycle the time will be extended by 15 seconds. The maximum delay is 3 minutes. Once modified, the fan off delay will not change back to 45 seconds unless power is reset to the control. A LED indicator is provided on the IGC to monitor operation.

Units with an Economizer

Cooling —

When free cooling is not available, the compressors will be controlled by the zone thermostat. When free cooling is available, the outdoor-air damper is modulated by the

economizer control to provide a 50°F (10°C) to 55°F (13°C) mixed-air temperature into the zone. As the mixed air temperature fluctuates above 55°F (13°C) or below 50°F (10°C) dampers will be modulated (open or close) to bring the mixed-air temperature back within control. If mechanical cooling is utilized with free cooling, the outdoor-air damper will maintain its current position at the time the compressor is started. If the increase in cooling capacity causes the mixed-air temperature to drop below 45°F (7°C), then the outdoor-air damper position will be decreased to the minimum position. If the mixed-air temperature continues to fall, the outdoor-air damper will close. Control returns to normal once the mixed-air temperature rises above 48°F (9°C). The power exhaust fans will be energized and de-energized, if installed, as the outdoor-air damper opens and closes.

If field-installed accessory CO₂ sensors are connected to the economizer control, a demand controlled ventilation strategy will begin to operate. As the CO₂ level in the zone increases above the CO₂ setpoint, the minimum position of the damper will be increased proportionally. As the CO₂ level decreases because of the increase in fresh air, the outdoor-air damper will be proportionally closed. For economizer operation, there must be a thermostat call for the fan (G). If the unit is occupied and the fan is on, the damper will operate at minimum position. Otherwise, the damper will be closed.

When the economizer control is in the occupied mode and a call for cooling exists (Y1 on the thermostat), the control will first check for indoor fan operation. If the fan is not on, then cooling will not be activated. If the fan is on, then the control will open the economizer damper to the minimum position.

On the initial power to the economizer control, it will take the damper up to 2 1/2 minutes before it begins to position itself. After the initial power-up, further changes in damper position can take up to 30 seconds to initiate. Damper movement from full closed to full open (or vice versa) will take between 1 1/2 and 2 1/2 minutes. If free cooling can be used as determined from the appropriate changeover command (switch, dry bulb, enthalpy curve, differential dry bulb, or differential enthalpy), then the control will modulate the dampers open to maintain the mixed-air temperature setpoint at 50°F (10°C) to 55°F (13°C). If there is a further demand for cooling (cooling second stage – Y2 is energized), then the control will bring on compressor stage 1 to maintain the mixed-air temperature setpoint. The economizer damper will be open at maximum position. economizer operation is limited to a single compressor.

Heating —

The sequence of operation for the heating is the same as a unit with no economizer. The only difference is how the economizer acts. The economizer will stay at the Economizer Minimum Position while the evaporator fan is operating. The outdoor-air damper is closed when the indoor fan is not operating. Refer to Service and Maintenance Manual for further details.

Normal Cooling

Refrigerant flows from the outdoor condenser through the normally open Cooling Valve (CV.x) to the expansion device. Reheat1 Valve (RH1.x) and Reheat2 Valve (RH2.x) are closed.

Reheat2 (Hot Gas Reheat Mode) – RGS210-300

This mode provides maximum latent cooling with little to no sensible capacity. This mode can operate to provide dehumidification when there is no cooling demand. Like Reheat1 mode, refrigerant flows from the outdoor condenser, through the normally open Reheat1 Valve (RH1.x), and through the reheat condenser coil to the expansion device. The Cooling Valve (CV.x) is closed. Reheat2 Valve (RH2.x) is open which provides some compressor discharge gas to the reheat condenser to further increase the reheat of the evaporator airstream.

GUIDE SPECIFICATIONS – RGS210 – 336

Note about this specification:

GAS HEAT PACKAGED ROOFTOP

HVAC Guide Specifications

Size Range: 17.5 to 27.5 Nominal Tons



<u>Section</u>	<u>Description</u>
----------------	--------------------

23 06 80	Schedules for Decentralized HVAC Equipment
-----------------	---

23 06 80.13	Decentralized Unitary HVAC Equipment Schedule
-------------	---

23 06 80.13.A.	Rooftop unit schedule
----------------	-----------------------

1. Schedule is per the project specification requirements.

23 07 16	HVAC Equipment Insulation
-----------------	----------------------------------

23 07 16.13	Decentralized, Rooftop Units:
-------------	-------------------------------

23 07 16.13.A.	Evaporator fan compartment:
----------------	-----------------------------

1. Interior cabinet surfaces shall be insulated with a minimum 1/2-in. thick, minimum 1 1/2 lb density, flexible fiber-glass insulation bonded with a phenolic binder, neoprene coated on the air side.
2. Insulation and adhesive shall meet NFPA 90A requirements for flame spread and smoke generation.

23 07 16.13.B.	Gas heat compartment:
----------------	-----------------------

1. Aluminum foil-faced fiberglass insulation shall be used.
2. Insulation and adhesive shall meet NFPA 90A requirements for flame spread and smoke generation.

23 09 13	Instrumentation and Control Devices for HVAC
-----------------	---

23 09 13.23	Sensors and Transmitters
-------------	--------------------------

23 09 13.23.A.	Thermostats
----------------	-------------

1. Thermostat must
 - a. energize both "W" and "G" when calling for heat.
 - b. have capability to energize 2 different stages of cooling, and 2 different stages of heating.
 - c. include capability for occupancy scheduling.

23 09 33	Electric and Electronic Control System for HVAC
-----------------	--

23 09 33.13	Decentralized, Rooftop Units:
-------------	-------------------------------

23 09 33.13.A.	General:
----------------	----------

1. Shall be complete with self-contained low-voltage control circuit protected by a resettable circuit breaker on the 24-v transformer side. Transformer shall have 75VA capability.
2. Shall utilize color-coded wiring.
3. Shall include a central control terminal board to conveniently and safely provide connection points for vital control functions such as: smoke detectors, phase monitor, gas controller, economizer, thermostat, and low and high pressure switches.
4. The heat exchanger shall be controlled by an integrated gas controller (IGC) microprocessor. See heat exchanger section of this specification.
5. Unit shall include a minimum of one 8-pin screw terminal connection board for connection of control wiring.

23 09 33.23.B.	Safeties:
----------------	-----------

1. Compressor over-temperature, over-current. High internal pressure differential.
2. Low-pressure switch.
 - a. Units shall have different sized connectors for the circuit 1 and circuit 2 low and high pressure switches. They shall physically prevent the cross-wiring of the safety switches between circuits 1 and 2.
 - b. Low pressure switch shall use different color wire than the high pressure switch. The purpose is to assist the installer and service technician to correctly wire and or troubleshoot the rooftop unit.

3. High-pressure switch.
 - a. Units shall have different sized connectors for the circuit 1 and circuit 2 low and high pressure switches. They shall physically prevent the cross-wiring of the safety switches between circuits 1 and 2.
 - b. High pressure switch shall use different color wire than the low pressure switch. The purpose is to assist the installer and service technician to correctly wire and or troubleshoot the rooftop unit.
4. Automatic reset, motor thermal overload protector.
5. Heating section shall be provided with the following minimum protections:
 - a. High-temperature limit switches.
 - b. Induced draft motor speed sensor.
 - c. Flame rollout switch.
 - d. Flame proving controls.

23 09 93 Sequence of Operations for HVAC Controls

23 09 93.13 Decentralized, Rooftop Units:

23 09 93.13 INSERT SEQUENCE OF OPERATION

23 40 13 Panel Air Filters

23 40 13.13 Decentralized, Rooftop Units:

23 40 13.13.A. Standard filter section

1. Shall consist of factory-installed, low velocity, disposable 2-in. thick fiberglass filters of commercially available sizes.
2. Unit shall use only one filter size. Multiple sizes are not acceptable.
3. Filters shall be accessible through a dedicated, weather tight access panel.
4. 4-in filter capabilities shall be capable with pre-engineered and approved filter track field installed accessory. This kit requires field furnished filters.

23 81 19 Self-Contained Air Conditioners

23 81 19.13 Medium-Capacity Self-Contained Air Conditioners (RGS210-336)

23 81 19.13.A. General

1. Outdoor, rooftop mounted, electrically controlled, heating and cooling unit utilizing a fully hermetic scroll compressor(s) for cooling duty and gas combustion for heating duty.
2. Factory assembled, single-piece heating and cooling rooftop unit. Contained within the unit enclosure shall be all factory wiring, piping, controls, and special features required prior to field start-up.
3. Unit shall use environmentally sound, R-410A refrigerant.
4. Unit shall be installed in accordance with the manufacturer's instructions.
5. Unit must be selected and installed in compliance with local, state, and federal codes.

23 81 19.13.B. Quality Assurance

1. Unit meets ASHRAE 90.1 minimum efficiency requirements.
2. Unit shall be rated in accordance with AHRI Standard 340/360.
3. Unit shall be designed to conform to ASHRAE 15.
4. Unit shall be ETL-tested and certified in accordance with ANSI Z21.47 Standards and ETL-listed and certified under Canadian standards as a total package for safety requirements.
5. Insulation and adhesive shall meet NFPA 90A requirements for flame spread and smoke generation.
6. Unit casing shall be capable of withstanding 500-hour salt spray exposure per ASTM B117 (scribed specimen).
7. Unit casing shall be capable of withstanding Federal Test Method Standard No. 141 (Method 6061) 5000-hour salt spray.
8. Unit shall be designed and manufactured in accordance with ISO 9001:2000.
9. Roof curb shall be designed to conform to NRCA Standards.
10. Unit shall be subjected to a completely automated run test on the assembly line. The data for each unit will be stored at the factory, and must be available upon request.
11. Unit shall be designed in accordance with UL Standard 1995, including tested to withstand rain.
12. Unit shall be constructed to prevent intrusion of snow and tested to prevent snow intrusion into the control box up to 40 mph.
13. Unit shake tested to assurance level 1, ASTM D4169 to ensure shipping reliability.
14. High Efficient Motors listed shall meet section 313 of the Energy Independence and Security Act of 2007 (EISA 2007).

23 81 19.13.C. Delivery, Storage, and Handling

1. Unit shall be stored and handled per manufacturer's recommendations.
2. Lifted by crane requires either shipping top panel or spreader bars.
3. Unit shall only be stored or positioned in the upright position.

23 81 19.13.D. Project Conditions

1. As specified in the contract.

23 81 19.13.E. Operating Characteristics

1. Unit shall be capable of starting and running at 115°F (46°C) ambient outdoor temperature, meeting maximum load criteria of AHRI Standard 340/360 at ± 10% voltage.
2. Compressor with standard controls shall be capable of operation down to 30°F (-1°C), ambient outdoor temperatures. Accessory winter start kit is necessary if mechanically cooling at ambient temperatures below 30°F (-1°C).
3. Unit shall discharge supply air vertically as shown on contract drawings.
4. Unit shall be factory configured and ordered for vertical supply & return configurations.
5. Unit shall be factory furnished for vertical configuration. No field conversion is required.

23 81 19.13.F. Electrical Requirements

1. Main power supply voltage, phase, and frequency must match those required by the manufacturer.

23 81 19.13.G. Unit Cabinet

1. Unit cabinet shall be constructed of galvanized steel, and shall be bonderized and coated with a pre-painted baked enamel finish on all externally exposed surfaces.
2. Unit cabinet exterior paint shall be: film thickness, (dry) 0.003 inches minimum, gloss (per ASTM D523, 60°F / 16°C): 60, Hardness: H-2H Pencil hardness.
3. Evaporator fan compartment interior cabinet insulation shall conform to AHRI Standard 340/360 minimum exterior sweat criteria. Interior surfaces shall be insulated with a minimum 1/2-in. thick, 1 lb density, flexible fiberglass insulation, neoprene coated on the air side. Aluminum foil-faced fiberglass insulation shall be used in the gas heat compartment.
4. Base of unit shall have a minimum of four locations for thru-the-base gas and electrical connections standard. Both gas and electric connections shall be internal to the cabinet to protect from environmental issues.
5. Base Rail
 - a. Unit shall have base rails on a minimum of 2 sides.
 - b. Holes shall be provided in the base rails for rigging shackles to facilitate maneuvering and overhead rigging.
 - c. Holes shall be provided in the base rail for moving the rooftop by fork truck.
 - d. Base rail shall be a minimum of 16 gauge thickness.
6. Condensate pan and connections:
 - a. Shall be a sloped condensate drain pan made of a non-corrosive material.
 - b. Shall comply with ASHRAE Standard 62.
 - c. Shall use a 3/4-in -14 NPT drain connection, through the side of the drain pan. Connection shall be made per manufacturer's recommendations.
7. Top panel:
 - a. Shall be a multi-piece top panel linked with water tight flanges and locking systems.
8. Gas Connections:
 - a. All gas piping connecting to unit gas valve shall enter the unit cabinet at a single location on side of unit (horizontal plane).
 - b. Thru-the-base capability
 - (1.) Standard unit shall have a thru-the-base gas-line location using a raised, embossed portion of the unit basepan.
 - (2.) Thru-the-base provisions/connections are available as standard with every unit. When bottom connections are required, field furnished couplings are required.
 - (3.) No basepan penetration, other than those authorized by the manufacturer, is permitted.
9. Electrical Connections
 - a. All unit power wiring shall enter unit cabinet at a single, factory-prepared, knockout location.
 - b. Thru-the-base capability.
 - (1.) Thru-the-base provisions/connections are available as standard with every unit. When bottom connections are required, field furnished couplings are required.
 - (2.) No basepan penetration, other than those authorized by the manufacturer, is permitted.

10. Component access panels (standard)

- a. Cabinet panels shall be easily removable for servicing.
- b. Unit shall have one factory installed, removable, filter access panel.
- c. Panels covering control box and filter shall have molded composite handles while the blower access door shall have an integrated flange for easy removal.
- d. Handles shall be UV modified, composite. They shall be permanently attached, and recessed into the panel.
- e. Screws on the vertical portion of all removable access panels shall engage into heat resistant, molded composite collars.
- f. Collars shall be removable and easily replaceable using manufacturer recommended parts.

23 81 19.13.H. Gas Heat

1. General

- a. Heat exchanger shall be an induced draft design. Positive pressure heat exchanger designs shall not be allowed.
- b. Shall incorporate a direct-spark ignition system and redundant main gas valve.
- c. Gas supply pressure at the inlet to the rooftop unit gas valve must match that required by the manufacturer.

2. The heat exchanger shall be controlled by an integrated gas controller (IGC) microprocessor.

- a. IGC board shall notify users of fault using an LED (light-emitting diode).
- b. IGC board shall contain algorithms that modify evaporator-fan operation to prevent future cycling on high temperature limit switch.
- c. Unit shall be equipped with anti-cycle protection with one short cycle on unit flame rollout switch or 4 continuous short cycles on the high temperature limit switch. Fault indication shall be made using an LED.

3. Standard Heat Exchanger construction

- a. Heat exchanger shall be of the tubular-section type constructed of a minimum of 20-gauge steel coated with a nominal 1.2 mil aluminum-silicone alloy for corrosion resistance.
- b. Burners shall be of the in-shot type constructed of aluminum-coated steel.
- c. Burners shall incorporate orifices for rated heat output up to 2000 ft (610m) elevation. Additional accessory kits may be required for applications above 2000 ft (610m) elevation, depending on local gas supply conditions.
- d. Each heat exchanger tube shall contain multiple dimples for increased heating effectiveness.

4. Optional Stainless Steel Heat Exchanger construction

- a. Use energy saving, direct-spark ignition system.
- b. Use a redundant main gas valve.
- c. Burners shall be of the in-shot type constructed of aluminum-coated steel.
- d. All gas piping shall enter the unit cabinet at a single location on side of unit (horizontal plane).
- e. The optional stainless steel heat exchanger shall be of the tubular-section type, constructed of a minimum of 20-gauge type 409 stainless steel.
- f. Type 409 stainless steel shall be used in heat exchanger tubes and vestibule plate.
- g. Complete stainless steel heat exchanger allows for greater application flexibility.

5. Induced draft combustion motor and blower

- a. Shall be a direct-drive, single inlet, forward-curved centrifugal type.
- b. Shall be made from steel with a corrosion-resistant finish.
- c. Shall have permanently lubricated sealed bearings.
- d. Shall have inherent thermal overload protection.
- e. Shall have an automatic reset feature.

23 81 19.13.I. Coils

1. Standard Aluminum Fin - Copper Tube Coils:

- a. Standard evaporator and condenser coils shall have aluminum lanced plate fins mechanically bonded to seamless internally grooved copper tubes with all joints brazed.
- b. Evaporator coils shall be leak tested to 150 psig, pressure tested to 450 psig, and qualified to UL 1995 burst test at 1775 psig.
- c. Condenser coils shall be leak tested to 150 psig, pressure tested to 650 psig, and qualified to UL 1995 burst test at 1980 psig.

2. Optional Pre-coated aluminum-fin condenser coils:

- a. Shall have a durable epoxy-phenolic coating to provide protection in mildly corrosive coastal environments.

- b. Coating shall be applied to the aluminum fin stock prior to the fin stamping process to create an inert barrier between the aluminum fin and copper tube.
 - c. Epoxy-phenolic barrier shall minimize galvanic action between dissimilar metals.
3. Optional Copper-fin evaporator and condenser coils:
- a. Shall be constructed of copper fins mechanically bonded to copper tubes and copper tube sheets.
 - b. Galvanized steel tube sheets shall not be acceptable.
 - c. A polymer strip shall prevent coil assembly from contacting the sheet metal coil pan to minimize potential for galvanic corrosion between coil and pan.
4. Optional E-coated aluminum-fin evaporator and condenser coils:
- a. Shall have a flexible epoxy polymer coating uniformly applied to all coil surface areas without material bridging between fins.
 - b. Coating process shall ensure complete coil encapsulation of tubes, fins and headers.
 - c. Color shall be high gloss black with gloss per ASTM D523-89.
 - d. Uniform dry film thickness from 0.8 to 1.2 mil on all surface areas including fin edges.
 - e. Superior hardness characteristics of 2H per ASTM D3363-92A and cross-hatch adhesion of 4B-5B per ASTM D3359-93.
 - f. Impact resistance shall be up to 160 in.-lb (ASTM D2794-93).
 - g. Humidity and water immersion resistance shall be up to minimum 1000 and 250 hours respectively (ASTM D2247-92 and ASTM D870-92).
 - h. Corrosion durability shall be confirmed through testing to be no less than 1000 hours salt spray per ASTM B117-90.

23 81 19.13.J. Refrigerant Components

1. Refrigerant circuit shall include the following control, safety, and maintenance features:
- a. Fixed orifice metering system on (non-Hot Gas Reheat units) shall prevent mal-distribution of two-phase refrigerant by including multiple fixed orifice devices in each refrigeration circuit. Each orifice is to be optimized to the coil circuit it serves.
 - b. Thermostatic Expansion Valve (TXV) shall help provide optimum performance across the entire operating range. Shall contain removable power element to allow change-out of power element and bulb without removing the valve body (for Hot Gas Reheat units only).
 - c. Refrigerant filter drier – Solid core design.
 - d. Service gauge connections on suction and discharge lines.
 - e. Pressure gauge access through a specially designed access screen on the side of the unit.
2. Compressors
- a. Unit shall use fully hermetic, scroll compressor for each independent refrigeration circuit.
 - b. Models shall be available with 2 compressor/2 stage cooling and microchannel condenser coils.
 - c. Compressor motors shall be cooled by refrigerant gas passing through motor windings.
 - d. Compressors shall be internally protected from high discharge temperature conditions.
 - e. Compressors shall be protected from an over-temperature and over-amperage conditions by an internal, motor overload device.
 - f. Compressor shall be factory mounted on rubber grommets.
 - g. Compressor motors shall have internal line break thermal, current overload and high pressure differential protection.
 - h. Crankcase heaters shall not be required for normal operating range, unless provided by the factory.

23 81 19.13.K. Filter Section

- 1. Filters access is specified in the unit cabinet section of this specification.
- 2. Filters shall be held in place by a preformed, slide-out filter tray, facilitating easy removal and installation.
- 3. Shall consist of factory-installed, low velocity, throw-away 2-in. thick fiberglass filters.
- 4. Filters shall be standard, commercially available sizes.
- 5. Only one size filter per unit is allowed.
- 6. 4-in filter capability is possible with a field installed pre engineered slide out filter track accessory. 4-in filters are field furnished.

23 81 19.13.L. Evaporator Fan and Motor

1. Evaporator fan motor:
- a. Shall have inherent automatic-reset thermal overload protection or circuit breaker.

- b. Shall have a maximum continuous bhp rating for continuous duty operation; no safety factors above that rating shall be required.

2. Belt-driven Evaporator Fan:

- a. Belt drive shall include an adjustable-pitch motor pulley and belt break protection system.
- b. Shall use rigid pillow block bearing system with lubricant fittings at accessible bearing or lubrication line.
- c. Blower fan shall be double-inlet type with forward-curved blades.
- d. Shall be constructed from steel with a corrosion resistant finish and dynamically balanced.

23 81 19.13.M. Condenser Fans and Motors

1. Condenser fan motors:

- a. Shall be a totally enclosed motor.
- b. Shall use permanently lubricated bearings.
- c. Shall have inherent thermal overload protection with an automatic reset feature.
- d. Shall use a shaft-down design.

2. Condenser Fans:

- a. Shall be a direct-driven propeller type fan.
- b. Shall have galvalum blades riveted to corrosion-resistant steel spiders and shall be dynamically balanced.

23 81 19.13.N. Special Features Options and Accessories

1. 2-Speed VFD drive motor system for 2-stage cooling models only:

a. Evaporator fan motor:

- (1.) Shall have permanently lubricated bearings.
- (2.) Shall have a maximum continuous bhp rating for continuous duty operation; no safety factors above that rating.
- (3.) Shall be Variable Frequency duty and 2-speed control.
- (4.) Shall contain motor shaft grounding ring to prevent electrical bearing fluting damage by safely diverting harmful shaft voltages and bearing currents to ground.

2. Variable Frequency Drive (VFD). Only available on 2-speed indoor fan motor option:

- a. Shall be installed inside the unit cabinet, mounted, wired and tested.
- b. Shall contain Electromagnetic Interference (EMI) frequency protection.
- c. Insulated Gate Bi-Polar Transistors (IGBT) used to produce the output pulse width modulated (PWM) waveform, allowing for quiet motor operation.
- d. Self diagnostics with fault and power code LED indicator. Field accessory Display Kit available for further diagnostics and special setup applications.
- e. RS485 capability standard.
- f. Electronic thermal overload protection.
- g. 5% swinging chokes for harmonic reduction and improved power factor.
- h. All printed circuit boards shall be conformal coated.

1. Standard Integrated Economizers:

- a. Integrated, gear-driven parallel modulating blade design type capable of simultaneous economizer and compressor operation.
- b. Independent modules for vertical or horizontal return configurations shall be available. Vertical return modules shall be available as a factory installed option or field installed accessory.
- c. Damper blades shall be galvanized steel with composite gears. Plastic or composite blades on intake or return shall not be acceptable.
- d. Shall include all hardware and controls to provide free cooling with outdoor air when temperature and/or humidity are below setpoints.
- e. Shall be equipped with gear driven dampers for both the outdoor ventilation air and the return air for positive air stream control.
- f. Standard models shall be equipped with low-leakage dampers, not to exceed 2% leakage at 1 in. wg pressure differential. Economizer controller on electromechanical units shall be Honeywell W7212 that provides:
 - (1.) Combined minimum and DCV maximum damper position potentiometers with compressor staging relay.
 - (2.) Functions with solid state analog enthalpy or dry bulb changeover control sensing.
 - (3.) Contain LED indicates for:
 - When free cooling is available
 - When module is in DCV mode
 - When exhaust fan contact is closed

- g. Ultra low leak Economizer X system shall be available on models with 2–speed Variable Frequency Drive (VFD) systems. Only available on 2–speed indoor fan motor systems with electromechanical controls or RTU Open.
 - (1.) Maximum damper leakage rate to be equal to or less than 4.0 cfm/sq. ft. at 1.0 in. w.g., meeting or exceeding ASHRAE 90.1 requirements. Economizer controller on electromechanical units shall be Honeywell W7220 that provides:
 - (2.) 2–line LCD interface screen for setup, configuration and troubleshooting.
 - (3.) On–board fault detection and diagnostics
 - (4.) Sensor failure loss of communication identification
 - (5.) Automatic sensor detection
 - (6.) Capabilities for use with multiple–speed indoor fan systems
 - (7.) Utilize digital sensors: Dry bulb and Enthalpy
 - h. Shall be capable of introducing up to 100% outdoor air.
 - i. Shall be equipped with a barometric relief damper capable of relieving up to 100% return air.
 - j. Shall be designed to close damper(s) during loss–of–power situations with spring return built into motor.
 - k. Dry bulb outdoor–air temperature sensor shall be provided as standard. Outdoor air sensor setpoint shall be adjustable and shall range from 40 to 100°F / 4 to 38°C. Additional sensor options shall be available as accessories.
 - l. The economizer controller shall also provide control of an accessory power exhaust unit function. Factory set at 100%, with a range of 0% to 100%.
 - m. The economizer shall maintain minimum airflow into the building during occupied period and provide design ventilation rate for full occupancy. A remote potentiometer may be used to override the damper setpoint.
 - n. Dampers shall be completely closed when the unit is in the unoccupied mode.
 - o. Economizer controller shall accept a 2–10Vdc CO₂ sensor input for IAQ/DCV control. In this mode, dampers shall modulate the outdoor–air damper to provide ventilation based on the sensor input.
 - p. Compressor lockout sensor shall open at 35°F (2°C) and close closes at 50°F (10°C).
 - q. Actuator shall be direct coupled to economizer gear. No linkage arms or control rods shall be acceptable.
 - r. Economizer controller shall provide indications when in free cooling mode, in the DCV mode, or the exhaust fan contact is closed.
2. Two–Position Motorized Damper
- a. Damper shall be a Two–Position Damper. Damper travel shall be from the full closed position to the field adjustable %–open setpoint.
 - b. Damper shall include adjustable damper travel from 25% to 100% (full open).
 - c. Damper shall include single or dual blade, gear driven dampers and actuator motor.
 - d. Actuator shall be direct coupled to damper gear. No linkage arms or control rods shall be acceptable.
 - e. Damper will admit up to 100% outdoor air for applicable rooftop units.
 - f. Damper shall close upon indoor (evaporator) fan shutoff and/or loss of power.
 - g. The damper actuator shall plug into the rooftop unit’s wiring harness plug. No hard wiring shall be required.
 - h. Outside air hood shall include aluminum water entrainment filter.
3. Manual damper
- a. Manual damper package shall consist of damper, air inlet screen, and rain hood which can be preset to admit up to 25% outdoor air for year round ventilation.
4. Hot Gas Reheat System (not available on 336 units):
- a. The Hot Gas Reheat System shall be factory installed and shall provide greater dehumidification of the occupied space by two modes of dehumidification operations in addition to its normal design cooling mode:
 - (1.) Subcooling mode further sub cools the hot liquid refrigerant leaving the condenser coil when both temperature and humidity in the space are not satisfied.
 - (2.) Hot gas reheat mode shall mix a portion of the hot gas from the discharge of the compressor with the hot liquid refrigerant leaving the condenser coil to create a two-phase heat transfer in the system, resulting in a neutral leaving air temperature when only humidity in the space is not satisfied.
 - (3.) Includes head pressure controller.
5. Head Pressure Control Package
- a. Controller shall control coil head pressure by condenser–fan speed modulation or condenser–fan cycling and wind baffles.

- b. Shall consist of solid-state control and condenser-coil temperature sensor to maintain condensing temperature between 90°F (32°C) and 110°F (43°C) at outdoor ambient temperatures down to -20°F (-29°C).
6. Propane Conversion Kit
 - a. Package shall contain all the necessary hardware and instructions to convert a standard natural gas unit for use with liquefied propane. Kits shall be available for elevations from 0 up to 14,000 ft (4,267m).
7. Condenser Coil Hail Guard Assembly
 - a. Shall protect against damage from hail.
 - b. Shall be louvered style design.
8. Unit-Mounted, Non-Fused Disconnect Switch:
 - a. Switch shall be factory-installed, internally mounted.
 - b. National Electric Code (NEC) and UL approved non-fused switch shall provide unit power shutoff.
 - c. Shall be accessible from outside the unit.
 - d. Shall provide local shutdown and lockout capability.
9. Convenience Outlet:
 - a. Non-Powered convenience outlet.
 - (1.) Outlet shall be powered from a separate 115/120v power source.
 - (2.) A transformer shall not be included.
 - (3.) Outlet shall be factory-installed and internally mounted with easily accessible 115-v female receptacle.
 - (4.) Outlet shall include 15 amp GFI receptacles with independent fuse protection.
 - (5.) Outlet shall be accessible from outside the unit.
10. Flue Discharge Deflector:
 - a. Flue discharge deflector shall direct unit exhaust vertically instead of horizontally.
 - b. Deflector shall be defined as a "natural draft" device by the National Fuel and Gas (NFG) code.
11. Centrifugal Propeller Power Exhaust: (Factory installed option or field installed accessory.)
 - a. Power exhaust shall be used in conjunction with an integrated economizer.
 - b. Independent modules for vertical or horizontal return configurations shall be available.
 - c. Power exhaust shall be controlled by economizer controller operation. Exhaust fans shall be energized when dampers open past the 0-100% adjustable setpoint on the economizer control.
12. Roof Curbs (Vertical):
 - a. Full perimeter roof curb with exhaust capability providing separate air streams for energy recovery from the exhaust air without supply air contamination.
 - b. Formed galvanized steel with wood nailer strip and shall be capable of supporting entire unit weight.
 - c. Permits installation and securing of ductwork to curb prior to mounting unit on the curb.
13. High Altitude Gas Conversion Kit:
 - a. Package shall contain all the necessary hardware and instructions to convert a standard natural gas unit to operate from 3,000-10,000 ft (914 to 3048m) elevation and 10,001-14,000 ft (3049-4267m) elevation.
14. Outdoor Air Enthalpy Sensor:
 - a. The outdoor air enthalpy sensor shall be used to provide single enthalpy control. When used in conjunction with a return air enthalpy sensor, the unit will provide differential enthalpy control. The sensor allows the unit to determine if outside air is suitable for free cooling.
15. Return Air Enthalpy Sensor:
 - a. The return air enthalpy sensor shall be used in conjunction with an outdoor air enthalpy sensor to provide differential enthalpy control.
16. Indoor Air Quality (CO₂) Sensor:
 - a. Shall be able to provide demand ventilation indoor air quality (IAQ) control.
 - b. The IAQ sensor shall be available in duct mount. The setpoint shall have adjustment capability.
17. Smoke detectors (Supply):
 - a. Shall be a Four-Wire Controller and Detector.
 - b. Shall be environmental compensated with differential sensing for reliable, stable, and drift-free sensitivity.
 - c. Shall use magnet-activated test/reset sensor switches.
 - d. Shall have tool-less connection terminal access.
 - e. Shall have a recessed momentary switch for testing and resetting the detector.
 - f. Controller shall include:

- (1.) One set of normally open alarm initiation contacts for connection to an initiating device circuit on a fire alarm control panel.
 - (2.) Two Form-C auxiliary alarm relays for interface with rooftop unit or other equipment.
 - (3.) One Form-C supervision (trouble) relay to control the operation of the Trouble LED on a remote test/reset station.
 - (4.) Capable of direct connection to two individual detector modules.
 - (5.) Can be wired to up to 14 other duct smoke detectors for multiple fan shutdown applications
18. Winter start kit
- a. Shall contain a bypass device around the low pressure switch.
 - b. Shall be required when mechanical cooling is required down to 25°F (-4°C).
 - c. Shall not be required to operate on an economizer when below an outdoor ambient of 40°F (4°C).
19. Time Guard
- a. Shall prevent compressor short cycling by providing a 5-minute delay (±2 minutes) before restarting a compressor after shutdown for any reason.
 - b. One device shall be required per compressor.
20. Display Kit for Variable Frequency Drive
- a. Kit allows the ability to access the VFD controller programs to provide special setup capabilities and diagnostics.
 - b. Kit contains display module, mounting bracket and communication cable.
 - c. Display Kit can be permanently installed in the unit or used on any 2 speed system VFD controller as needed.
21. Hinged Access Panels:
- a. Shall provide easy access through hinged access doors with vinyl coated door retainers.
 - b. Shall be on major panels of – filter, control box and fan motor.