

## MK - CONTROL BOARD SPECIFICATIONS



### Control Board Specifications

MK012AWA

MK018AWA

MK024AWA

MK030AWA

MK036AWA

MK048AWA

MK060AWA

## MK - CONTROL BOARD SPECIFICATIONS

<b>PRODUCT CODE :</b>	<b>MK012AWA - MK060AWA</b>
<b>PRODUCT NAME :</b>	<b>Universal mount fan coil AC or HP</b>

### FUNCTION SPECIFICATION :

- 5 modes controllable. (Cool, Dry, Fan, Heat and Auto)
- 4 Kinds for fan speed control. (Low, Med., High and Auto)
- Temperature setting range 15<sup>o</sup> - 30<sup>o</sup> C.
- Freeze and over-heat protection.(evaporator)
- Frost and Hi-temp protection. (condenser)
- 3 minutes delay protection for compressor restart.
- 1 minutes delay protection for 4 way valve restart.
- Stepping motor controllable.
- Sleep function controllable.
- Auto restart function after power voltage has been transient failed.
- Emergency switch control function Cool, Heat and Off.
- Other service include Freeze prevention system for fan coils when unit is in the Cool and Dry mode, and built-in missing temperature sensors detector system.
- Remote controllable up to 8M. distance
- 180V-240VAC. Working voltage range. (Under Voltage Protection)

### BODY SPECIFICATION

- PCB main H985 s107x131 mm. (CEM-1)
- PCB control H985D2 s19x5 mm. (FR-4)
- 1 tact switch for emergency control. (Cool-Heat-Off)
- 2 pcs of LEDs 3mm. (height 9 mm.) display.
  - 1 pcs. Red color (transparent) for Power on/off status.
  - 1 pcs. Green color (transparent) for timer on/off setting status.
- 6 pcs. Relays for control the in-door fan, valve, Comp. and out-door fan.

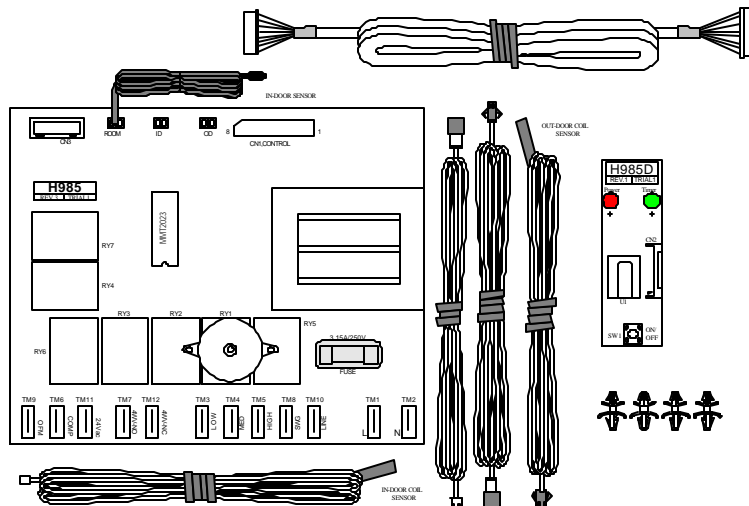

# MK - CONTROL BOARD SPECIFICATIONS

## MAIN CONTROL :

### Cooling mode

Room temp set point	4WV	Comp	Coil temp	Indoor Fan	Sweep
Troom => Tset. +1°C	OFF	ON	<=24°C	setting operation	Setting operation
	OFF	ON	=>27°C	OFF	OFF
Troom <= TSet	OFF	OFF	<=24°C	Low	setting
	OFF	OFF	=>27°C	OFF	OFF

### Heating mode

Room temp set point	4WV	Comp	Coil temp	Indoor Fan	Sweep
Troom <=Tset- 1°C	ON	ON	=>35°C	Setting operation	Setting Operation
	ON	ON	<=32°C	Refer to fig above	OFF
	ON	ON	<=18°C	OFF	OFF
Troom => Tset+1°C	ON	OFF	=>35°C	Refer to fig above	setting operation
	ON	OFF	<=32°C	Refer to fig above	OFF
	ON	OFF	<=18°C	OFF	OFF

### Drying mode

Condition	4WV	Comp.		Fan speed	
		Off	On	Off	On
Troom > Tset	OFF	-	Always	-	Always
Tset- 2°C<=Troom<=Tset+1°C.	OFF	250sec	210sec	12sec	24sec
Tset- 3°C<=Troom<=Tset-2°C.	OFF	285sec	175sec	12sec	24sec
15°C<=Troom<=Tset- 3°C.	OFF	330sec	160sec	12sec	24sec
Troom < 15°C	OFF	Always	-	12sec	24sec

### Fan only mode

Remote controller's L - M - H only. (Auto does not function.)

### Sleep function

Mode	Condition	4WV	Comp	Fan speed
Cooling	Troom > Tset (till Troom=Tset)	OFF	ON	LOW
	Start Sleep Troom >Tset+1°C		OFF	
	Troom > Tset+2°C		ON	
	After 1hr. Troom >Tset+2°C		OFF	
Heating	Troom > Tset+3°C	ON	ON	LOW
	Troom < Tset (till Troom=Tset)		OFF	
	Start sleep Troom < Tset-1°C		ON	
	Troom < Tset-2°C		OFF	
	After 1hr. Troom < Tset-2°C		ON	
Troom < Tset-3°C	ON			

## LED DISPLAY :

LED	Off	Bright	Blinking
Power	Power off	Power on	System protection
Timer	Timer cancel	Setting timer	Sensor missing

# MK - CONTROL BOARD SPECIFICATIONS

## EMERGENCY SWITCH :

To operate the air-conditioner at the default setting.

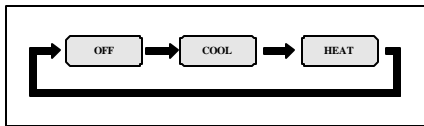

Mode	Tset	Fan speed	Timer and sleep
Cooling	24°C	Auto	Cancel
Heating	24°C	Auto	Cancel

## STEPPING MOTOR CONTROL

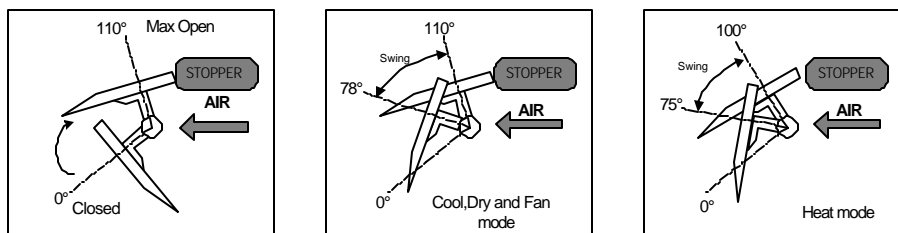

The actual angle of control : 93 - 125°

## OTHER FUNCTION

### - INDOOR COIL FREEZE PROTECTION

When the indoor coil temperature has been fallen below 0°C for 3 minute, the compressor and outdoor fan will turn off, the power LED will blinking. Until the indoor coil temperature exceeds 5°C and the compressor has been rested for 3 minutes period. The compressor and outdoor fan will be restart again, the power LED will stop blinking.

### - INDOOR COIL OVER-HEAT PROTECTION

In the heat mode, when compressor is running, if indoor coil temperature has rise at 65°C for 2minute , the compressor and outdoor fan will turn off, indoor fan runs at low speed and the power LED will blinking. Until the indoor coil temperature has been fallen below 50°C and the compressor has been rested for 3 minutes period. The compressor and outdoor fan will be restart again and the power LED stop blinking, indoor fan running at setting speed.

### - OUTDOOR COIL HI-TEMP. PROTECTION

When the outdoor temperature has been rise at 65°C for 3 minutes, the compressor will turn off, Outdoor fan runs continuous and indoor fan runs at low speed. Until the outdoor coil temperature has been fallen below 50°C. and the compressor has been rested for 3 minutes period. The compressor and outdoor fan will be re-start again, the power LED stop blinking, indoor fan running at setting speed.

## **MK - CONTROL BOARD SPECIFICATIONS**

### **- PRESSURE CONTROL**

In the Cooling and Drying mode operation, if the outdoor coil temperature has been fallen below 30°C the outdoor fan will turn off. Until the outdoor coil temperature has been rise at 38°C. the outdoor fan will turn on again.

### **- OUTDOOR COIL FROST PROTECTION AND DEFROST**

In the heating mode, when the outdoor coil temperature dips below 3°C., the defrost timer starts.

if the temperature is increased to be above 3°C. for 2 minutes, the defrost timer is clear.

The system controller will start the defrost process when, the defrost time meets on of the below conditions, and the compressor has been continuous running for 5 minutes in the heating mode.

1. The outdoor coil temperature is reduced +3°C to -8°C., during 30-60 minutes and remain at -8°C. or below.
2. The outdoor coil temperature is reduced +3°C to -4°C., during 60-120 minutes and remain at -4°C. or below.
3. The outdoor coil temperature is reduced +3°C to -2°C., after 120 minutes and remain at -2°C. or below.

While the defrost function is activated

- The indoor fan ,outdoor fan and reversing valve will turn off, while the compressor runs.
- The power LED will blinking.

The system will return to normal status when,

- The outdoor coil temperature has been rise at 14°C. or the defrost function operates more than 10 minutes.
- The air conditioner is turned off.

# MK - CONTROL BOARD SPECIFICATIONS

## MAIN PCB

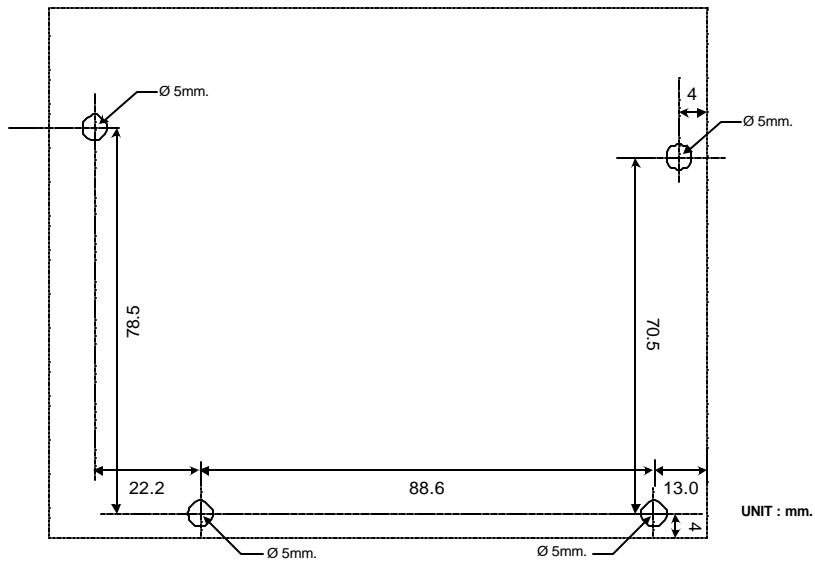
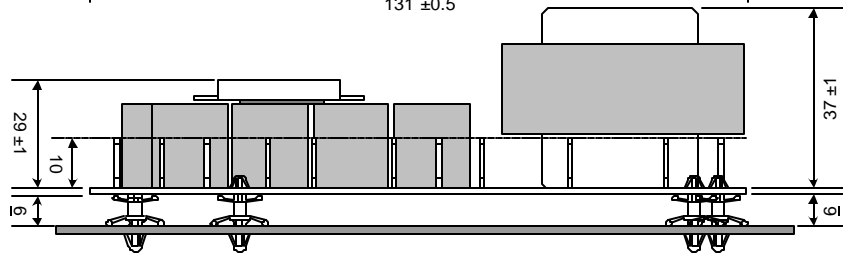
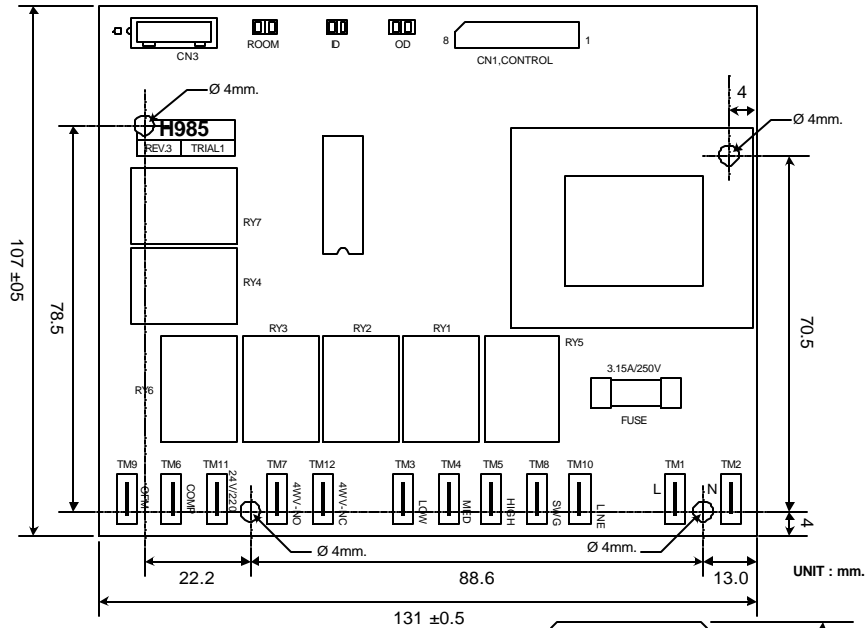

# MK - CONTROL BOARD SPECIFICATIONS

## DISPLAY PCB

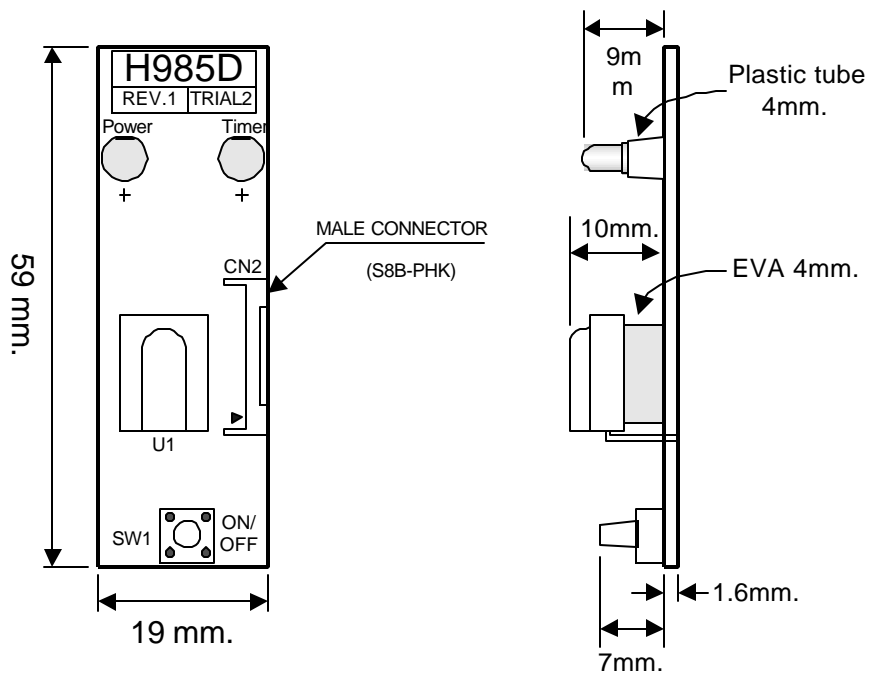

# MK - CONTROL BOARD SPECIFICATIONS

## TEMPERATURE SENSOR

RETURN AIR OR IN-DOOR SENSOR :  
WITH 50cm. LONG CABLE AND CONNECTOR



EVAPORATOR OR FREEZE SENSOR :  
WITH 1.8m. LONG CABLE AND CONNECTOR

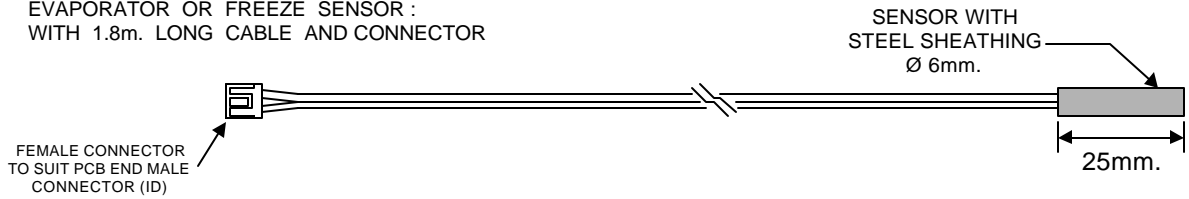

CONDENSING OR OUT-DOOR SENSOR :  
WITH CABLE AND CONNECTOR

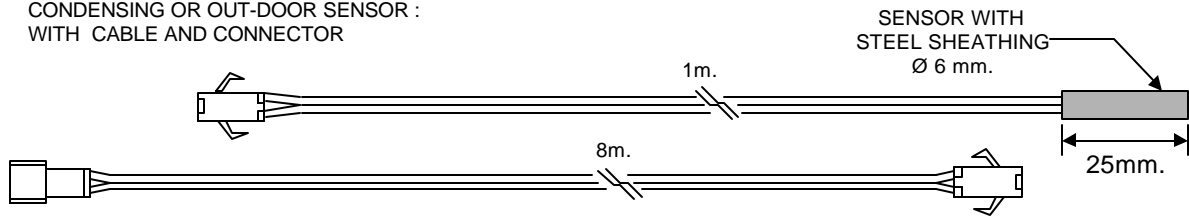

FEMALE CONNECTOR TO SUIT PCB END MALE CONNECTOR (OD)

1.8m. LONG CABLE AND CONNECTOR FOR DISPLAY

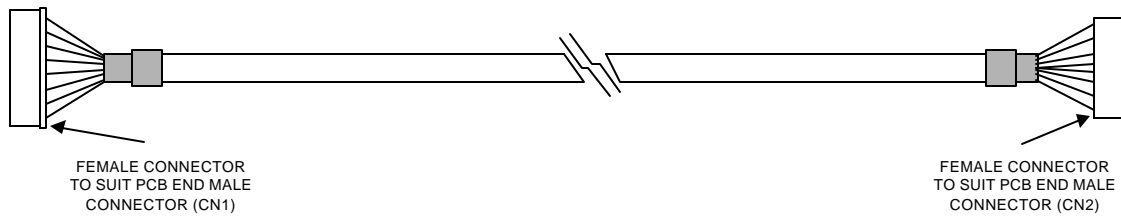



# MK - CONTROL BOARD SPECIFICATIONS

## CONNECTION DIAGRAM

**LEGEND :**

- L - Line
- N - Neutral
- GND - Ground
- FAN - Fan motor
- LOW - Low speed fan
- MED - Med. speed fan
- HIGH - High speed fan
- COMP - Compressor
- OFM - Out-door fan
- 4WV - Reversing valve
- STP - Stepping motor
- CAP - Capacitor

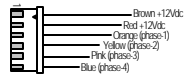

XHP-6 (JST)

