



15 SEER, PACKAGE GAS / ELECTRIC UNIT, 2 - 5 TONS

Single Phase, 208/230 V, 60 Hz

REFRIGERATION CIRCUIT

- Environmentally sound R-410A refrigerant
- Copper tube/aluminum fin condenser and evaporator coils
- Two stage scroll compressors standard on all models

EASY TO INSTALL AND SERVICE

- Installs easily on a rooftop or at ground level
- Easy single-panel accessibility for maintenance and installation
- Easily converts to down discharge applications
- Combination gas heating and electric cooling

BUILT TO LAST

- Wire grille
- NOx-approved units available
- Induced-draft combustion and venting
- Pre-painted steel cabinet
- Direct spark ignition
- High efficiency X-13 indoor blower motor on all models
- Aluminized steel heat exchanger
- Vertical condenser fan discharge
- Rust-proof base with integral sloping drain
- High and low pressure switches provide added reliability for the compressor

LIMITED WARRANTY

- 15-year heat exchanger limited warranty
- 10-year compressor limited warranty
- 5-year parts limited warranty



As an Energy Star® Partner, International Comfort Products has determined that this product meets the ENERGY STAR® guidelines for energy efficiency.



UNIT PERFORMANCE DATA

Model Number	COOLING			HEATING		Unit Dimensions Height x Width x Depth Inches (mm)	Operating Weight lbs / kg
	Net Capacity BTU/h High / Low Stage	S.E.E.R	E.E.R.	Input BTU/h High/Low	Efficiency AFUE %		
PGN524040K0*A	22,600 / 17,600	15.5	11.4	40,000 / 26,000	78.0	41x48x33 (1041x1226x831)	396 (180)
PGN524060K0*A	22,600 / 17,600	15.5	11.4	60,000 / 39,000	78.6	41x48x33 (1041x1226x831)	401 (182)
PGN536060K0*A	34,600 / 24,400	15.0	12.0	60,000 / 39,000	78.6	45x48x44 (1093x1226x1123)	485 (220)
PGN536090K0*A	34,600 / 24,400	15.0	12.0	90,000 / 58,500	79.2	45x48x44 (1093x1226x1123)	493 (224)
PGN548090K0*A	46,000 / 33,400	15.0	11.0	90,000 / 58,500	79.2	47x48x44 (1193x1226x1123)	521 (236)
PGN548115K0*A	46,000 / 33,400	15.0	11.0	115,000 / 75,000	80.1	47x48x44 (1193x1226x1123)	521 (236)
PGN548130K0*A	46,000 / 33,400	15.0	11.0	130,000 / 84,500	80.0	47x48x44 (1193x1226x1123)	521 (236)
PGN560090K0*A	57,000 / 40,500	14.5	11.0	90,000 / 58,500	79.2	51x48x44 (1295x1226x1123)	512 (260)
PGN560115K0*A	57,000 / 40,500	14.5	11.0	115,000 / 75,000	80.1	51x48x44 (1295x1226x1123)	512 (260)
PGN560130K0*A	57,000 / 40,500	14.5	11.0	130,000 / 84,500	80.0	51x48x44 (1295x1226x1123)	512 (260)

* 0 = Standard Model, 1 = Low NOx California Model

462 11 2101 00

11/21/08

Not yet approved for sale in California (not yet listed with CEC - California Energy Commission)

UNIT SPECIFICATIONS

UNIT SIZE	24040	24060	36060	36090	48090
NOMINAL COOLING CAPACITY (ton)	2	2	3	3	4
NOMINAL HEATING INPUT (Btu/hr)	40,000	60,000	60,000	90,000	90,000
OPERATING WEIGHT (lb/kg)	396/179.6	401/181.9	485/220.0	493/223.6	521/236.3
COMPRESSOR	Two-Stage Scroll				
REFRIGERANT (R-410A) QUANTITY (lb/kg)	10.1/4.6	10.1/4.6	9.5/4.3	9.5/4.3	15.3/6.9
REFRIGERANT METERING DEVICE	TXV				
Size	2 Ton	2 Ton	3 Ton	3 Ton	4 Ton
Part Number	EA36YD129	EA36YD129	EA36YD139	EA36YD139	EA36YD149
OUTDOOR FAN					
Nominal CFM	2700	2700	2800	2800	3300
Diameter (in./mm)	22/559	22/559	22/559	22/559	22/559
Motor HP (RPM)	1/8 (825)	1/8 (825)	1/8 (825)	1/8 (825)	1/4 (1100)
OUTDOOR COIL					
Rows...Fins/in	2...21	2...21	2...21	2...21	2...21
Face Area (sq. ft.)	13.6	13.6	17.5	17.5	19.4
INDOOR COIL					
Rows...Fins/in	3...17	3...17	3...17	3...17	3...17
Face Area (sq. ft.)	3.7	3.7	4.7	4.7	5.7
INDOOR BLOWER					
Nominal Low Stage Airflow (CFM)	600	600	850	850	1100
Nominal High Stage Airflow (CFM)	800	800	1200	1200	1600
Blower Wheel Size (in. x in.)	10x10	10x10	11x10	11x10	11x10
Blower Wheel Size (mm x mm)	254x254	254x254	279x254	279x254	279x254
Motor HP (RPM)	1/2	1/2	3/4	3/4	1
FURNACE SECTION					
Natural Gas Burner Orifice No. (Qty...Drill Size)*	2...44	3...44	3...44	3...38	3...38
HIGH-PRESSURE SWITCH (psig)					
Cutout	670+/- 10				
Reset (Auto)	470+/- 25				
HIGH-PRESSURE SWITCH 2 (psig) (Compressor Solenoid)					
Cutout	565+/- 15				
Reset (Auto)	455+/- 15				
LOSS-OF-CHARGE/LOW-PRESSURE SWITCH (Liquid Line) (psig)					
Cutout	23+/- 5				
Reset (Auto)	55+/- 5				
RETURN-AIR FILTERS (in.) Throwaway**	20x24x1	24x30x1		24x36x1	
RETURN-AIR FILTERS (mm) Throwaway**	508x610x25	610x762x25		610x914x25	

* Based on altitude of 0 to 2000 ft (0 to 610 m).

** Recommended filter sizes for field-installed air filter grilles mounted on the wall or ceiling of the conditioned structure. Required filter sizes shown are based on the ARI (Air Conditioning and Refrigeration Institute) rated high stage cooling airflow and a maximum face velocity of 300 ft/minute for throwaway filters or 450 ft/minute for permanent filters. Air filter pressure drop for non-standard filters must not exceed .08 inches water column.

UNIT SPECIFICATIONS					
UNIT SIZE	48115	48130	60090	60115	60130
NOMINAL COOLING CAPACITY (ton)	4	4	5	5	5
NOMINAL HEATING INPUT (Btu/hr)	115,000	130,000	90,000	115,000	130,000
OPERATING WEIGHT (lb/kg)	521/236.3	521/236.3	572/259.5	572/259.5	572/259.5
COMPRESSOR	Two-Stage Scroll				
REFRIGERANT (R-410A) QUANTITY (lb/kg)	15.3/6.9	15.3/6.9	15.8/7.2	15.8/7.2	15.8/7.2
REFRIGERANT METERING DEVICE	TXV				
Size	4 Ton	4 Ton	5 Ton	5 Ton	5 Ton
Part Number	EA36YD149	EA36YD149	EA36YD159	EA36YD159	EA36YD159
OUTDOOR FAN					
Nominal CFM	3300	3300	3300	3300	3300
Diameter (in./mm)	22/559	22/559	22/559	22/559	22/559
Motor HP (RPM)	1/4 (1100)	1/4 (1100)	1/3 (1110)	1/3 (1110)	1/3 (1110)
OUTDOOR COIL					
Rows...Fins/in	2...21	2...21	2...21	2...21	2...21
Face Area (sq. ft.)	19.4	19.4	23.3	23.3	23.3
INDOOR COIL					
Rows...Fins/in	3...17	3...17	4...17	4...17	4...17
Face Area (sq. ft.)	5.7	5.7	5.7	5.7	5.7
INDOOR BLOWER					
Nominal Low Stage Airflow (CFM)	1100	1100	1200	1200	1200
Nominal High Stage Airflow (CFM)	1600	1600	1750	1750	1750
Blower Wheel Size (in. x in.)	11x10	11x10	11x10	11x10	11x10
Blower Wheel Size (mm x mm)	279x254	279x254	279x254	279x254	279x254
Motor HP (RPM)	1	1	1	1	1
FURNACE SECTION					
Natural Gas Burner Orifice No. (Qty...Drill Size)*	3...33	3...31	3...38	3...33	3...31
HIGH-PRESSURE SWITCH (psig)					
Cutout	670+/- 10				
Reset (Auto)	470+/- 25				
HIGH-PRESSURE SWITCH 2 (psig) (Compressor Solenoid)					
Cutout	565+/- 15				
Reset (Auto)	455+/- 15				
LOSS-OF-CHARGE/LOW-PRESSURE SWITCH (Liquid Line) (psig)					
Cutout	23+/- 5				
Reset (Auto)	55+/- 5				
RETURN-AIR FILTERS (in.) Throwaway**	24x36x1				
RETURN-AIR FILTERS (mm) Throwaway**	610x914x25				

* Based on altitude of 0 to 2000 ft (0 to 610 m).

** Recommended filter sizes for field-installed air filter grilles mounted on the wall or ceiling of the conditioned structure. Required filter sizes shown are based on the ARI (Air Conditioning and Refrigeration Institute) rated high stage cooling airflow and a maximum face velocity of 300 ft/minute for throwaway filters or 450 ft/minute for permanent filters. Air filter pressure drop for non-standard filters must not exceed .08 inches water column.

UNIT AIRFLOW, Horizontal and Downflow Discharge, 230 Volts, Dry Coil

Unit	Heating Rise Range	Motor Speed	Wire Color		External Static Pressure (”WC)								
					0.1	0.2	0.3	0.4	0.5	0.6	0.7	0.8	0.9
PGN524040	30 - 60°F (17 - 33°C)	Low1	Blue	CFM	659	551	440	355	-	-	-	-	-
				Heating Rise (°F)	46	55	NA	NA	NA	NA	NA	NA	NA
				Heating Rise (°C)	25	30	NA	NA	NA	NA	NA	NA	NA
		Med-Low	Pink	CFM	726	625	537	407	-	-	-	-	-
				Heating Rise (°F)	42	48	56	NA	NA	NA	NA	NA	NA
				Heating Rise (°C)	23	27	31	NA	NA	NA	NA	NA	NA
		Medium2	Red	CFM	907	837	759	679	588	474	343	-	-
				Heating Rise (°F)	33	36	40	45	51	NA	NA	NA	NA
				Heating Rise (°C)	19	20	22	25	29	NA	NA	NA	NA
		Med-High3	Orange	CFM	953	870	807	718	652	528	443	-	-
				Heating Rise (°F)	32	35	37	42	46	57	NA	NA	NA
				Heating Rise (°C)	18	19	21	23	26	32	NA	NA	NA
		High	Black	CFM	1179	1118	1061	996	942	864	794	718	619
				Heating Rise (°F)	NA	NA	NA	30	32	35	38	42	49
				Heating Rise (°C)	NA	NA	NA	17	18	19	21	23	27
PGN524060	25 - 55°F (14 - 31°C)	Low1	Blue	CFM	659	551	440	355	-	-	-	-	-
				Heating Rise (°F)	NA	NA	NA	NA	NA	NA	NA	NA	NA
				Heating Rise (°C)	NA	NA	NA	NA	NA	NA	NA	NA	NA
		Med-Low	Pink	CFM	726	625	537	407	-	-	-	-	-
				Heating Rise (°F)	NA	NA	NA	NA	NA	NA	NA	NA	NA
				Heating Rise (°C)	NA	NA	NA	NA	NA	NA	NA	NA	NA
		Medium2	Red	CFM	907	837	759	679	588	474	343	-	-
				Heating Rise (°F)	49	53	NA	NA	NA	NA	NA	NA	NA
				Heating Rise (°C)	27	29	NA	NA	NA	NA	NA	NA	NA
		Med-High	Orange	CFM	953	870	807	718	652	528	443	-	480
				Heating Rise (°F)	47	51	55	NA	NA	NA	NA	NA	NA
				Heating Rise (°C)	26	28	31	NA	NA	NA	NA	NA	NA
		High3	Black	CFM	1179	1118	1061	996	942	864	794	718	619
				Heating Rise (°F)	38	40	42	45	47	51	NA	NA	NA
				Heating Rise (°C)	21	22	23	25	26	29	NA	NA	NA
PGN536060	25 - 55°F (14 - 31°C)	Low1	Blue	CFM	921	740	448	-	-	-	-	-	-
				Heating Rise (°F)	48	NA	NA	NA	NA	NA	NA	NA	NA
				Heating Rise (°C)	27	NA	NA	NA	NA	NA	NA	NA	NA
		Med-Low	Pink	CFM	1019	849	603	479	-	-	-	-	-
				Heating Rise (°F)	44	52	NA	NA	NA	NA	NA	NA	NA
				Heating Rise (°C)	24	29	NA	NA	NA	NA	NA	NA	NA
		Medium3	Red	CFM	1272	1203	1150	1097	1054	996	937	881	841
				Heating Rise (°F)	35	37	39	41	42	45	47	50	53
				Heating Rise (°C)	19	21	21	23	23	25	26	28	29
		Med-High2	Orange	CFM	1321	1258	1212	1168	1114	1075	1009	956	904
				Heating Rise (°F)	34	35	37	38	40	41	44	46	49
				Heating Rise (°C)	19	20	20	21	22	23	24	26	27
		High	Black	CFM	1478	1426	1387	1334	1292	1247	1212	1148	1108
				Heating Rise (°F)	30	31	32	33	34	36	37	39	40
				Heating Rise (°C)	17	17	18	19	19	20	20	22	22
PGN536090	35 - 65°F (19 - 36°C)	Low1	Blue	CFM	921	740	448	-	-	-	-	-	-
				Heating Rise (°F)	NA	NA	NA	NA	NA	NA	NA	NA	NA
				Heating Rise (°C)	NA	NA	NA	NA	NA	NA	NA	NA	NA
		Med-Low	Pink	CFM	1019	849	603	479	-	-	-	-	-
				Heating Rise (°F)	NA	NA	NA	NA	NA	NA	NA	NA	NA
				Heating Rise (°C)	NA	NA	NA	NA	NA	NA	NA	NA	NA
		Medium	Red	CFM	1272	1203	1150	1097	1054	996	937	881	841
				Heating Rise (°F)	53	57	59	62	65	NA	NA	NA	NA
				Heating Rise (°C)	30	31	33	34	36	NA	NA	NA	NA
		Med-High2	Orange	CFM	1321	1258	1212	1168	1114	1075	1009	956	904
				Heating Rise (°F)	51	54	56	58	61	63	NA	NA	NA
				Heating Rise (°C)	29	30	31	32	34	35	NA	NA	NA
		High3	Black	CFM	1478	1426	1387	1334	1292	1247	1212	1148	1108
				Heating Rise (°F)	46	48	49	51	53	55	56	59	61
				Heating Rise (°C)	26	26	27	28	29	30	31	33	34

UNIT AIRFLOW, Horizontal and Downflow Discharge, 230 Volts, Dry Coil

Unit	Heating Rise Range	Motor Speed	Wire Color		External Static Pressure (”WC)								
					0.1	0.2	0.3	0.4	0.5	0.6	0.7	0.8	0.9
PGN548090	35 - 65°F (19 - 36°C)	Low1	Blue	CFM	1201	1159	1101	1062	1004	957	897	852	793
				Heating Rise (°F)	57	59	62	64	NA	NA	NA	NA	NA
				Heating Rise (°C)	31	33	34	36	NA	NA	NA	NA	NA
		Med-Low3	Pink	CFM	1419	1364	1318	1258	1214	1160	1118	1053	1009
				Heating Rise (°F)	48	50	52	54	56	59	61	65	NA
				Heating Rise (°C)	27	28	29	30	31	33	34	36	NA
		Medium2	Red	CFM	1678	1635	1602	1558	1513	1474	1438	1404	1349
				Heating Rise (°F)	41	42	42	44	45	46	47	48	50
				Heating Rise (°C)	23	23	24	24	25	26	26	27	28
		Med-High	Orange	CFM	1916	1881	1846	1810	1761	1722	1681	1647	1600
				Heating Rise (°F)	35	36	37	38	39	39	40	41	43
				Heating Rise (°C)	20	20	20	21	21	22	22	23	24
		High	Black	CFM	2093	2051	2024	1967	1947	1907	1854	1826	1749
				Heating Rise (°F)	NA	NA	NA	35	35	36	37	37	39
				Heating Rise (°C)	NA	NA	NA	19	19	20	20	21	22
PGN548115	30 - 60°F (17 - 33°C)	Low1	Blue	CFM	1201	1159	1101	1062	1004	957	897	852	793
				Heating Rise (°F)	NA	NA	NA	NA	NA	NA	NA	NA	NA
				Heating Rise (°C)	NA	NA	NA	NA	NA	NA	NA	NA	NA
		Med-Low	Pink	CFM	1419	1364	1318	1258	1214	1160	1118	1053	1009
				Heating Rise (°F)	NA	NA	NA	NA	NA	NA	NA	NA	NA
				Heating Rise (°C)	NA	NA	NA	NA	NA	NA	NA	NA	NA
		Medium2	Red	CFM	1678	1635	1602	1558	1513	1474	1438	1404	1349
				Heating Rise (°F)	52	53	54	56	57	59	60	NA	NA
				Heating Rise (°C)	29	30	30	31	32	33	34	NA	NA
		Med-High	Orange	CFM	1916	1881	1846	1810	1761	1722	1681	1647	1600
				Heating Rise (°F)	45	46	47	48	49	50	52	53	54
				Heating Rise (°C)	25	26	26	27	27	28	29	29	30
		High3	Black	CFM	2093	2051	2024	1967	1947	1907	1854	1826	1749
				Heating Rise (°F)	42	42	43	44	45	46	47	48	50
				Heating Rise (°C)	23	24	24	25	25	25	26	26	28
PGN548130	35 - 65°F (19 - 36°C)	Low1	Blue	CFM	1201	1159	1101	1062	1004	957	897	852	793
				Heating Rise (°F)	NA	NA	NA	NA	NA	NA	NA	NA	NA
				Heating Rise (°C)	NA	NA	NA	NA	NA	NA	NA	NA	NA
		Med-Low	Pink	CFM	1419	1364	1318	1258	1214	1160	1118	1053	1009
				Heating Rise (°F)	NA	NA	NA	NA	NA	NA	NA	NA	NA
				Heating Rise (°C)	NA	NA	NA	NA	NA	NA	NA	NA	NA
		Medium2	Red	CFM	1678	1635	1602	1558	1513	1474	1438	1404	1349
				Heating Rise (°F)	57	59	60	62	64	65	NA	NA	NA
				Heating Rise (°C)	32	33	33	34	35	36	NA	NA	NA
		Med-High	Orange	CFM	1916	1881	1846	1810	1761	1722	1681	1647	1600
				Heating Rise (°F)	50	51	52	53	55	56	57	58	60
				Heating Rise (°C)	28	28	29	30	30	31	32	32	33
		High3	Black	CFM	2093	2051	2024	1967	1947	1907	1854	1826	1749
				Heating Rise (°F)	46	47	48	49	49	50	52	53	55
				Heating Rise (°C)	26	26	26	27	27	28	29	29	31
PGN560090	35 - 65°F (19 - 36°C)	Low1	Blue	CFM	1320	1256	1211	1142	1096	1028	973	903	835
				Heating Rise (°F)	52	54	56	60	62	NA	NA	NA	NA
				Heating Rise (°C)	29	30	31	33	34	NA	NA	NA	NA
		Med-Low3	Pink	CFM	1351	1295	1258	1212	1170	1124	1080	1036	992
				Heating Rise (°F)	50	53	54	56	58	60	63	NA	NA
				Heating Rise (°C)	28	29	30	31	32	34	35	NA	NA
		Medium2	Red	CFM	1824	1782	1742	1711	1673	1641	1607	1563	1490
				Heating Rise (°F)	37	38	39	40	41	41	42	44	46
				Heating Rise (°C)	21	21	22	22	23	23	24	24	25
		Med-High	Orange	CFM	2001	1958	1923	1883	1831	1776	1705	1624	1538
				Heating Rise (°F)	NA	35	35	36	37	38	40	42	44
				Heating Rise (°C)	NA	19	20	20	21	21	22	23	25
		High	Black	CFM	2292	2238	2158	2049	1935	1840	1732	1635	1513
				Heating Rise (°F)	NA	NA	NA	NA	35	37	39	42	45
				Heating Rise (°C)	NA	NA	NA	NA	20	21	22	23	25

UNIT AIRFLOW, Horizontal and Downflow Discharge, 230 Volts, Dry Coil

Unit	Heating Rise Range	Motor Speed	Wire Color		External Static Pressure (W.C.)									
					0.1	0.2	0.3	0.4	0.5	0.6	0.7	0.8	0.9	
PGN560115	30 - 60°F (17 - 33°C)	Low1	Blue	CFM	1320	1256	1211	1142	1096	1028	973	903	835	
				Heating Rise (°F)	NA	NA	NA	NA	NA	NA	NA	NA	NA	NA
				Heating Rise (°C)	NA	NA	NA	NA	NA	NA	NA	NA	NA	NA
		Med-Low	Pink	CFM	1351	1295	1258	1212	1170	1124	1080	1036	992	
				Heating Rise (°F)	NA	NA	NA	NA	NA	NA	NA	NA	NA	
				Heating Rise (°C)	NA	NA	NA	NA	NA	NA	NA	NA	NA	
		Medium2	Red	CFM	1824	1782	1742	1711	1673	1641	1607	1563	1490	
				Heating Rise (°F)	48	49	50	51	52	53	54	56	58	
				Heating Rise (°C)	26	27	28	28	29	29	30	31	32	
		Med-High3	Orange	CFM	2001	1958	1923	1883	1831	1776	1705	1624	1538	
				Heating Rise (°F)	43	44	45	46	47	49	51	54	56	
				Heating Rise (°C)	24	25	25	26	26	27	28	30	31	
		High	Black	CFM	2292	2238	2158	2049	1935	1840	1732	1635	1513	
				Heating Rise (°F)	38	39	40	42	45	47	50	53	57	
				Heating Rise (°C)	21	22	22	24	25	26	28	30	32	
PGN560130	35 - 65°F (19 - 36°C)	Low1	Blue	CFM	1320	1256	1211	1142	1096	1028	973	903	835	
				Heating Rise (°F)	NA	NA	NA	NA	NA	NA	NA	NA	NA	
				Heating Rise (°C)	NA	NA	NA	NA	NA	NA	NA	NA	NA	
		Med-Low	Pink	CFM	1351	1295	1258	1212	1170	1124	1080	1036	992	
				Heating Rise (°F)	NA	NA	NA	NA	NA	NA	NA	NA	NA	
				Heating Rise (°C)	NA	NA	NA	NA	NA	NA	NA	NA	NA	
		Medium2	Red	CFM	1887	1847	1783	1726	1677	1625	1578	1527	1432	
				Heating Rise (°F)	51	52	54	56	57	59	61	63	NA	
				Heating Rise (°C)	28	29	30	31	32	33	34	35	NA	
		Med-High3	Orange	CFM	2001	1958	1923	1883	1831	1776	1705	1624	1538	
				Heating Rise (°F)	48	49	50	51	53	54	56	59	63	
				Heating Rise (°C)	27	27	28	28	29	30	31	33	35	
		High	Black	CFM	2292	2238	2158	2049	1935	1840	1732	1635	1513	
				Heating Rise (°F)	42	43	45	47	50	52	56	59	64	
				Heating Rise (°C)	23	24	25	26	28	29	31	33	35	

* Air delivery values are without air filter and are for dry coil (See Table 15 - PGN5 Wet Coil Pressure Drop table).

- 1 Factory-shipped low stage cooling speed
- 2 Factory-shipped high stage cooling speed
- 3 Factory-shipped heating speed
- "NA" = Not allowed for heating speed

Note: Deduct field-supplied air filter pressure drop and wet coil pressure drop to obtain external static pressure available for ducting.

FILTER PRESSURE DROP

FILTER SIZE	CFM																		
	500	600	700	800	900	1000	1100	1200	1300	1400	1500	1600	1700	1800	1900	2000	2100	2200	2300
	Pressure Drop (inches water column)																		
20 x 24 x 1	—	—	—	—	0.09	0.1	0.11	0.13	0.14	0.15	0.16	—	—	—	—	—	—	—	—
24 x 30 x 1	—	—	—	—	—	—	—	0.07	0.08	0.09	0.1	0.11	0.12	0.13	0.14	0.15	0.16	0.17	0.18
24 x 36 x 1	—	—	—	—	—	—	—	0.06	0.07	0.07	0.08	0.09	0.09	0.10	0.11	0.12	0.13	0.14	0.14

Minimum Filter Requirements:

- 20 x 24 x 1 = PGN524
- 24 x 30 x 1 = PGN536
- 24 x 36 x 1 = PGN548, PGN560

WET COIL PRESSURE DROP (IN. W.C.)

Unit Size	STANDARD CFM (SCFM)															
	600	700	800	900	1000	1100	1200	1300	1400	1500	1600	1700	1800	1900	2000	2100
24	0.005	0.007	0.010	0.012	0.015	-	-	-	-	-	-	-	-	-	-	-
36	-	-	-	0.019	0.023	0.027	0.032	0.037	0.042	0.047	-	-	-	-	-	-
48	-	-	-	-	-	-	0.027	0.032	0.036	0.041	0.046	0.052	0.057	0.063	0.068	-
60	-	-	-	-	-	-	-	-	-	0.029	0.032	0.036	0.040	0.045	0.049	0.053

UNIT ELECTRICAL SPECIFICATIONS

MODEL NUMBER	Nominal V-PH-HZ	Voltage Range		Compressor		OFM	IFM	IDM	Power Supply	
		Min.	Max.	RLA	LRA	FLA	FLA	FLA	MCA	MOCP
PGN524040	208/230-1-60	187	253	10.3	52	0.9	4.1	0.7	17.9	25
PGN524060				10.3	52	0.9	4.1	1.7	17.9	25
PGN536060				16.7	82	0.9	6.0	1.7	27.8	40
PGN536090				16.7	82	0.9	6.0	0.7	27.8	40
PGN548090				21.2	96	1.5	7.6	0.7	35.6	50
PGN548115				21.2	96	1.5	7.6	1.7	35.6	50
PGN548130				21.2	96	1.5	7.6	0.5	35.6	50
PGN560090				25.6	118	1.9	7.6	0.7	41.5	60
PGN560115				25.6	118	1.9	7.6	1.7	41.5	60
PGN560130				25.6	118	1.9	7.6	0.5	41.5	60

LEGEND

- FLA -- Full Load Amps
- LRA -- Locked Rotor Amps
- MCA -- Minimum Circuit Amps
- MOCP -- Maximum Overcurrent Protection
- RLA -- Rated Load Amps



EXAMPLE: Supply voltage is 230-3-60.



AB = 228 v
 BC = 231 v
 AC = 227 v

$$\begin{aligned} \text{Average Voltage} &= \frac{228 + 231 + 227}{3} \\ &= \frac{686}{3} \\ &= 229 \end{aligned}$$

NOTES:

- In compliance with NEC (National Electrical Code) requirements for multimotor and combination load equipment (refer to NEC Articles 430 and 440), the overcurrent protective device for the unit shall be Power Supply fuse. The CGA (Canadian Gas Association) units may be fuse or circuit breaker.
- Minimum wire size is based on 60 C copper wire. If other than 60 C wire is used, or if length exceeds wire length in table, determine size from NEC.
- Unbalanced 3-Phase Supply Voltage
Never operate a motor where a phase imbalance in supply voltage is greater than 2%. Use the following formula to determine the percentage of voltage imbalance

% Voltage imbalance

$$= 100 \times \frac{\text{max voltage deviation from average voltage}}{\text{average voltage}}$$

Determine maximum deviation from average voltage.

- (AB) 229 - 228 = 1 v
- (BC) 231 - 229 = 2 v
- (AC) 229 - 227 = 2 v

Maximum deviation is 2 v.

Determine percent of voltage imbalance

$$\begin{aligned} \% \text{ Voltage Imbalance} &= 100 \times \frac{2}{229} \\ &= 0.8\% \end{aligned}$$

This amount of phase imbalance is satisfactory as it is below the maximum allowable 2%.

IMPORTANT: If the supply voltage phase imbalance is more than 2%, contact your local electric utility company immediately.

PGN524 EXTENDED COOLING PERFORMANCE - HIGH COOL

CONDENSER ENTERING AIR TEMPERATURES deg F

EVAPORATOR AIR		75 (23.8°C)						85 (29.4°C)						95 (35°C)						105 (40.5°C)						115 (46.1°C)						125 (51.6°C)					
		CFM		Capacity MBtuh		Total System KW	Capacity MBtuh		Total System KW	Capacity MBtuh		Total System KW	Capacity MBtuh		Total System KW	Capacity MBtuh		Total System KW	Capacity MBtuh		Total System KW	Capacity MBtuh		Total System KW	Capacity MBtuh		Total System KW										
				Total	Sens		Total	Sens		Total	Sens		Total	Sens		Total	Sens		Total	Sens		Total	Sens		Total	Sens		Total	Sens	Total	Sens						
700	57	21.77	21.77	1.61	20.88	20.88	1.79	19.95	19.95	2.00	18.94	18.94	2.23	17.86	17.86	2.48	16.66	16.66	2.77																		
	62	22.40	18.69	1.61	21.29	18.21	1.80	20.13	17.70	2.00	18.95	18.95	2.23	17.86	17.86	2.48	16.66	16.66	2.77																		
	63	22.85	15.18	1.62	21.71	14.70	1.80	20.52	14.21	2.01	19.25	13.70	2.23	17.90	13.16	2.48	16.42	12.58	2.77																		
	67	24.66	15.72	1.64	23.44	15.24	1.83	22.15	14.75	2.03	20.79	14.24	2.26	19.34	13.70	2.51	17.74	13.12	2.79																		
	72	27.16	12.75	1.67	25.83	12.28	1.86	24.42	11.80	2.06	22.94	11.29	2.29	21.33	10.76	2.54	19.57	10.18	2.83																		
800	57	22.76	22.76	1.64	21.81	21.81	1.82	20.81	20.81	2.03	19.74	19.74	2.26	18.58	18.58	2.51	17.29	17.29	2.80																		
	62	22.97	20.16	1.64	21.84	21.76	1.82	20.81	20.81	2.03	19.74	19.74	2.26	18.58	18.58	2.51	17.29	17.29	2.80																		
	63	23.39	16.20	1.64	22.19	15.71	1.83	20.94	15.21	2.03	19.62	14.69	2.26	18.22	14.14	2.51	16.69	13.54	2.79																		
	67	25.22	16.81	1.67	23.94	16.32	1.85	22.60	15.82	2.05	21.18	15.30	2.28	19.67	14.74	2.53	18.01	14.14	2.82																		
	72	27.77	13.43	1.70	26.37	12.96	1.88	24.90	12.48	2.09	23.35	11.95	2.31	21.66	11.41	2.57	20.60	11.05	2.57																		

PGN524 EXTENDED COOLING PERFORMANCE - LOW COOL

CONDENSER ENTERING AIR TEMPERATURES deg F

EVAPORATOR AIR		75 (23.8°C)						85 (29.4°C)						95 (35°C)						105 (40.5°C)						115 (46.1°C)						125 (51.6°C)					
		CFM		Capacity MBtuh		Total System KW	Capacity MBtuh		Total System KW	Capacity MBtuh		Total System KW	Capacity MBtuh		Total System KW	Capacity MBtuh		Total System KW	Capacity MBtuh		Total System KW	Capacity MBtuh		Total System KW	Capacity MBtuh		Total System KW										
				Total	Sens		Total	Sens		Total	Sens		Total	Sens		Total	Sens		Total	Sens		Total	Sens		Total	Sens		Total	Sens	Total	Sens						
525	57	16.65	16.65	1.05	15.95	15.95	1.20	15.21	15.21	1.37	14.40	14.40	1.57	13.52	13.52	1.80	12.55	12.55	2.07																		
	62	17.20	14.47	1.06	16.29	14.07	1.21	15.34	13.65	1.37	14.40	14.40	1.57	13.52	13.52	1.80	12.55	12.55	2.07																		
	63	17.61	11.75	1.06	16.69	11.36	1.21	15.70	10.96	1.38	14.64	10.53	1.57	13.50	10.07	1.80	12.27	9.58	2.06																		
	67	19.23	12.26	1.08	18.23	11.87	1.22	17.18	11.47	1.39	16.05	11.03	1.58	14.83	10.58	1.81	13.50	10.09	2.07																		
	72	21.48	10.05	1.09	20.41	9.66	1.24	19.26	9.26	1.41	18.02	8.84	1.60	16.69	8.39	1.83	15.24	7.90	2.09																		
600	57	17.52	17.52	1.08	16.77	16.77	1.23	15.96	15.96	1.39	15.10	15.10	1.59	14.15	14.15	1.82	13.11	13.11	2.09																		
	62	17.71	15.66	1.08	16.78	16.75	1.23	15.96	15.96	1.39	15.10	15.10	1.59	14.15	14.15	1.82	13.12	13.12	2.09																		
	63	18.10	12.58	1.08	17.12	12.18	1.23	16.09	11.76	1.39	14.98	11.32	1.59	13.80	10.85	1.81	12.51	10.35	2.08																		
	67	19.75	13.14	1.09	18.71	12.74	1.24	17.60	12.32	1.41	16.41	11.88	1.60	15.14	11.41	1.83	13.76	10.91	2.09																		
	72	22.06	10.61	1.11	20.93	10.21	1.26	19.72	9.80	1.43	18.41	9.36	1.62	17.03	8.91	1.85	15.51	8.41	2.11																		

PGN536 EXTENDED COOLING PERFORMANCE - HIGH COOL

EVAPORATOR AIR		CONDENSER ENTERING AIR TEMPERATURES deg F																	
		75 (23.8°C)			85 (29.4°C)			95 (35°C)			105 (40.5°C)			115 (46.1°C)			125 (51.6°C)		
		CFM	EWB	Capacity MBtuh	Total System KW	Capacity MBtuh	Total System KW	Capacity MBtuh	Total System KW	Capacity MBtuh	Total System KW	Capacity MBtuh	Total System KW	Capacity MBtuh	Total System KW	Capacity MBtuh	Total System KW		
		Total	Sens	Total	Sens	Total	Sens	Total	Sens	Total	Sens	Total	Sens	Total	Sens	Total	Sens		
	57	33.64	33.64	2.28	32.32	32.32	30.90	30.90	2.81	29.36	29.36	3.11	27.65	27.65	3.46	25.71	25.71	3.84	
	62	34.47	28.72	2.29	32.83	28.00	31.11	27.24	2.81	29.36	29.36	3.11	27.65	27.65	3.46	25.71	25.71	3.84	
1050	63	35.12	23.25	2.29	33.44	22.56	31.65	21.83	2.81	29.73	21.07	3.12	27.64	20.25	3.45	25.33	19.35	3.83	
	67	37.76	24.04	2.32	35.94	23.34	34.00	22.61	2.84	31.91	21.83	3.15	29.65	21.00	3.49	27.14	20.10	3.87	
	73	42.16	18.41	2.37	40.12	17.73	37.93	17.01	2.90	35.58	16.24	3.20	33.02	15.43	3.54	30.21	14.53	3.92	
	57	35.06	35.06	2.32	33.64	33.64	32.12	32.12	2.85	30.46	30.46	3.16	28.63	28.63	3.50	26.56	26.56	3.89	
	62	35.29	30.91	2.33	33.64	33.64	32.12	32.12	2.85	30.46	30.46	3.16	28.63	28.63	3.50	26.56	26.56	3.89	
1200	63	35.86	24.79	2.33	34.09	24.08	32.22	23.34	2.85	30.23	22.56	3.15	28.05	21.71	3.49	25.66	20.78	3.87	
	67	38.52	25.68	2.36	36.62	24.97	34.60	24.22	2.88	32.43	23.43	3.19	30.06	22.57	3.53	27.47	21.64	3.90	
	73	42.99	19.31	2.41	40.85	18.61	38.57	17.87	2.93	36.13	17.09	3.24	33.48	16.25	3.58	30.56	15.35	3.96	

PGN536 EXTENDED COOLING PERFORMANCE - LOW COOL

EVAPORATOR AIR		CONDENSER ENTERING AIR TEMPERATURES deg F																	
		75 (23.8°C)			85 (29.4°C)			95 (35°C)			105 (40.5°C)			115 (46.1°C)			125 (51.6°C)		
		CFM	EWB	Capacity MBtuh	Total System KW	Capacity MBtuh	Total System KW	Capacity MBtuh	Total System KW	Capacity MBtuh	Total System KW	Capacity MBtuh	Total System KW	Capacity MBtuh	Total System KW	Capacity MBtuh	Total System KW		
		Total	Sens	Total	Sens	Total	Sens	Total	Sens	Total	Sens	Total	Sens	Total	Sens	Total	Sens		
	57	23.27	23.27	1.46	22.34	22.34	21.31	21.31	1.87	20.19	20.19	2.12	18.95	18.95	2.41	17.58	17.58	2.76	
	62	23.91	20.06	1.46	22.70	19.54	21.41	18.97	1.87	20.19	20.19	2.12	18.95	18.95	2.41	17.58	17.58	2.76	
745	63	24.46	16.28	1.47	23.21	15.77	21.87	15.23	1.87	20.42	14.65	2.12	18.85	14.03	2.41	17.14	13.96	2.75	
	67	26.63	16.96	1.48	25.29	16.45	23.85	15.90	1.89	22.28	15.32	2.14	20.58	14.69	2.43	18.72	14.02	2.77	
	72	29.67	13.86	1.51	28.20	13.35	26.61	12.81	1.91	24.89	12.23	2.16	23.01	11.60	2.45	20.96	10.93	2.79	
	57	24.45	24.45	1.48	23.43	23.43	22.33	22.33	1.89	21.11	21.11	2.14	19.80	19.80	2.44	18.32	18.32	2.78	
	62	24.61	21.68	1.48	23.43	23.43	22.33	22.33	1.89	21.12	21.12	2.14	19.80	19.80	2.44	18.32	18.32	2.78	
850	63	25.11	17.42	1.49	23.80	16.89	22.39	16.34	1.89	20.88	15.74	2.14	19.24	15.10	2.43	17.46	14.42	2.77	
	67	27.33	18.17	1.50	25.92	17.64	24.40	17.08	1.91	22.76	16.48	2.15	20.99	15.84	2.44	19.06	15.15	2.78	
	72	30.44	14.64	1.53	28.89	14.12	27.21	13.55	1.93	25.40	12.96	2.17	23.45	12.33	2.46	21.30	11.65	2.80	

PGN548 EXTENDED COOLING PERFORMANCE - HIGH COOL

CONDENSER ENTERING AIR TEMPERATURES deg F																			
EVAPORATOR AIR		75 (23.8°C)			85 (29.4°C)			95 (35°C)			105 (40.5°C)			115 (46.1°C)			125 (51.6°C)		
CFM	EWB	Capacity MBtuh		Total System KW	Capacity MBtuh		Total System KW	Capacity MBtuh		Total System KW	Capacity MBtuh		Total System KW	Capacity MBtuh		Total System KW	Capacity MBtuh		Total System KW
		Total	Sens		Total	Sens		Total	Sens		Total	Sens		Total	Sens		Total	Sens	
1400	57	44.39	44.39	3.40	42.70	42.70	3.71	40.87	40.87	4.05	38.88	38.88	4.43	36.67	36.67	4.84	34.16	34.16	5.30
	62	45.43	38.20	3.41	43.33	37.29	3.72	41.11	36.31	4.05	38.87	38.87	4.43	36.67	36.67	4.84	35.30	35.30	4.84
	63	46.29	30.85	3.42	44.11	29.95	3.73	41.79	29.00	4.06	39.28	28.00	4.43	36.54	26.91	4.84	33.51	25.73	5.29
	67	50.04	32.01	3.46	47.71	31.11	3.77	45.21	30.16	4.11	42.50	29.14	4.48	41.00	28.60	4.43	36.24	26.85	5.34
	72	55.24	25.88	3.53	52.68	24.98	3.84	49.93	24.04	4.18	46.96	23.04	4.55	45.43	22.53	4.52	40.04	20.75	5.41
	57	46.32	46.32	3.48	44.10	44.10	3.79	42.54	42.54	4.13	40.41	40.41	4.51	38.04	38.04	4.92	36.62	36.62	4.93
	62	46.57	41.09	3.48	44.43	44.43	3.79	42.54	42.54	4.13	41.40	41.40	4.51	38.04	38.04	4.92	36.61	36.61	4.93
1600	63	47.25	32.81	3.49	44.97	31.89	3.80	42.55	30.92	4.13	39.95	29.90	4.50	37.11	28.80	4.91	33.97	27.59	5.36
	67	51.07	34.10	3.53	48.62	33.18	3.84	46.00	32.20	4.18	43.19	31.17	4.55	40.12	30.06	4.96	38.36	29.43	4.97
	72	56.36	27.17	3.60	53.67	26.25	3.91	50.80	25.29	4.25	47.69	24.26	4.62	44.30	23.15	5.03	42.55	22.59	5.06

PGN548 EXTENDED COOLING PERFORMANCE - LOW COOL

CONDENSER ENTERING AIR TEMPERATURES deg F																			
EVAPORATOR AIR		75 (23.8°C)			85 (29.4°C)			95 (35°C)			105 (40.5°C)			115 (46.1°C)			125 (51.6°C)		
CFM	EWB	Capacity MBtuh		Total System KW	Capacity MBtuh		Total System KW	Capacity MBtuh		Total System KW	Capacity MBtuh		Total System KW	Capacity MBtuh		Total System KW	Capacity MBtuh		Total System KW
		Total	Sens		Total	Sens		Total	Sens		Total	Sens		Total	Sens		Total	Sens	
965	57	31.49	31.49	2.22	30.30	30.30	2.49	29.02	29.02	2.78	27.63	27.63	3.12	26.10	26.10	3.51	24.40	24.40	3.96
	62	32.49	27.41	2.21	30.96	26.74	2.48	29.34	26.03	2.78	27.64	27.57	3.12	26.10	26.10	3.51	24.40	24.40	3.97
	63	33.19	22.28	2.21	31.62	21.62	2.48	29.95	20.92	2.78	28.14	20.18	3.12	26.19	19.39	3.52	24.04	18.53	3.97
	67	36.14	23.21	2.21	34.45	22.54	2.47	32.65	21.84	2.77	30.72	21.10	3.10	28.62	20.30	3.49	26.31	19.44	3.94
	72	40.19	19.02	2.21	38.34	18.36	2.46	36.37	17.67	2.75	34.25	16.93	3.08	31.95	16.14	3.46	29.40	15.29	3.90
	57	33.04	33.04	2.24	31.76	31.76	2.50	30.39	30.39	2.80	28.90	28.90	3.13	27.27	27.27	3.52	25.45	25.45	3.97
	62	33.42	29.57	2.23	31.85	28.86	2.50	30.39	30.39	2.80	28.90	28.90	3.13	27.27	27.27	3.52	25.45	25.45	3.97
1100	63	34.05	23.76	2.23	32.40	23.08	2.50	30.64	22.37	2.80	28.77	21.61	3.14	26.73	20.81	3.53	24.50	19.92	3.99
	67	37.06	24.78	2.23	35.29	24.10	2.49	33.40	23.38	2.78	31.39	22.62	3.12	29.20	21.81	3.51	26.79	20.93	3.95
	72	41.21	20.03	2.23	39.26	19.35	2.48	37.19	18.64	2.77	34.96	17.88	3.10	32.54	17.07	3.48	29.89	16.19	3.92

PGN560 EXTENDED COOLING PERFORMANCE - HIGH COOL

EVAPORATOR AIR		CONDENSER ENTERING AIR TEMPERATURES deg F																	
		75 (23.8°C)			85 (29.4°C)			95 (35°C)			105 (40.5°C)			115 (46.1°C)			125 (51.6°C)		
		CFM	EWB	Capacity MBtuh Total	Sens	Total System KW	Capacity MBtuh Total	Sens	Total System KW	Capacity MBtuh Total	Sens	Total System KW	Capacity MBtuh Total	Sens	Total System KW	Capacity MBtuh Total	Sens	Total System KW	
2000	57	58.24	58.24	4.41	55.10	55.10	4.84	54.80	54.80	4.69	52.40	52.40	5.23	46.70	46.70	6.40	42.90	42.90	7.02
	62	58.46	54.46	4.42	55.79	55.79	4.84	55.36	55.36	4.69	52.73	52.73	5.23	46.94	46.94	6.40	43.20	43.20	7.02
	63	59.23	43.33	4.42	56.27	42.07	4.85	55.68	41.83	4.69	52.48	40.49	5.22	45.80	37.74	6.37	41.56	36.02	6.97
	67	63.56	44.86	4.50	60.35	43.59	4.92	56.88	42.24	5.38	56.62	42.14	5.93	48.97	39.21	6.44	44.37	37.49	7.05
	72	69.55	35.33	4.59	66.01	34.07	5.02	62.20	32.73	5.48	58.07	31.30	5.99	53.51	29.74	6.54	48.46	28.03	7.15
	57	56.01	56.01	4.29	53.76	53.76	4.72	51.30	51.30	5.19	50.80	50.80	5.08	45.20	45.20	6.27	41.70	41.70	6.89
	62	57.19	50.62	4.31	54.45	49.37	4.73	51.51	48.01	5.19	50.93	47.74	5.08	45.50	45.50	6.27	41.99	41.99	6.89
1750	63	58.18	40.75	4.32	55.35	39.51	4.74	52.28	38.20	5.20	51.66	37.95	5.10	45.27	35.27	6.26	41.16	33.59	6.87
	67	62.48	42.11	4.39	59.41	40.86	4.81	57.00	39.90	5.18	55.71	39.39	5.21	48.47	36.58	6.34	44.00	34.88	6.94
	72	68.41	33.69	4.48	65.01	32.46	4.91	61.35	31.14	5.37	57.37	29.72	5.88	52.97	28.19	6.44	48.09	26.53	7.04

PGN560 EXTENDED COOLING PERFORMANCE - LOW COOL

EVAPORATOR AIR		CONDENSER ENTERING AIR TEMPERATURES deg F																	
		75 (23.8°C)			85 (29.4°C)			95 (35°C)			105 (40.5°C)			115 (46.1°C)			125 (51.6°C)		
		CFM	EWB	Capacity MBtuh Total	Sens	Total System KW	Capacity MBtuh Total	Sens	Total System KW	Capacity MBtuh Total	Sens	Total System KW	Capacity MBtuh Total	Sens	Total System KW	Capacity MBtuh Total	Sens	Total System KW	
1200	57	39.88	39.88	2.70	38.34	38.34	3.04	36.64	36.64	3.43	34.74	34.74	3.87	31.90	31.90	4.37	29.70	29.70	4.94
	62	40.94	35.96	2.69	39.01	35.09	3.04	36.90	34.14	3.43	34.90	34.90	3.87	32.60	32.60	4.37	30.16	30.16	4.94
	63	41.76	29.14	2.69	39.78	28.27	3.04	37.61	27.34	3.42	35.23	26.33	3.87	32.61	25.22	4.37	29.69	24.04	4.96
	67	45.04	30.17	2.68	42.87	29.29	3.02	40.50	28.35	3.40	37.91	27.31	3.84	35.04	26.21	4.33	31.84	25.00	4.90
	72	49.59	24.40	2.68	47.18	23.52	3.01	44.52	22.56	3.38	41.68	21.55	3.80	38.47	20.43	4.28	34.93	19.21	4.84
	57	41.69	41.69	2.72	40.00	40.00	3.07	37.90	37.90	3.45	35.45	35.45	3.89	33.62	33.62	4.38	30.90	30.90	4.95
	62	41.98	38.83	2.72	40.02	40.02	3.07	38.18	38.18	3.45	36.13	36.13	3.89	33.82	33.82	4.38	31.19	31.19	4.95
1370	63	42.72	31.09	2.72	40.63	30.20	3.07	38.35	29.24	3.45	35.86	28.21	3.89	33.13	27.09	4.40	30.10	25.87	4.98
	67	46.03	32.23	2.72	43.75	31.34	3.05	41.27	30.36	3.43	38.55	29.32	3.86	35.56	28.18	4.36	32.25	26.93	4.92
	72	50.62	25.68	2.71	48.09	24.78	3.04	45.37	23.83	3.41	42.32	22.77	3.83	39.01	21.64	4.31	35.34	20.40	4.86

* 63° F Ewb is at 75° F entering dry bulb – Tennessee Valley Authority [TVA] rating conditions; all others at 80° F entering dry bulb.

LEGEND: BF — Bypass Factor Ewb — Entering Wet Bulb kW — Total Unit Power Input SHC — Sensible Heat Capacity (x1000 Btuh) TC — Total Capacity (x1000 Btuh) (net)

NOTES:

1. Ratings are net; they account for the effects of the evaporator fan motor power and heat.
2. Direct interpolation is permissible. Do not extrapolate.
3. The following formulas may be used:

$$t_{ldb} = t_{edb} - \frac{\text{Sensible Capacity (BTU/h)}}{1.10 \times \text{cfm}}$$

$$h_{lwb} = h_{Ewb} - \frac{\text{Total Capacity (BTU/h)}}{4.5 \times \text{cfm}}$$

Where: h_{Ewb} = Enthalpy of air entering evaporator coil

t_{lwb} = Wet bulb temperature corresponding to enthalpy of air leaving evaporator coil (h_{lwb})

4. The SHC is based on 80° F Edb temperature of air entering evaporator coil.

Below 80° F Edb, subtract (corr factor x cfm) from SHC.

Above 80° F Edb, add (corr factor x cfm) to SHC. Correction Factor = $1.10 \times (1 + BF) \times (Edb + 80)$.

ACCESSORIES

ROOF CURBS

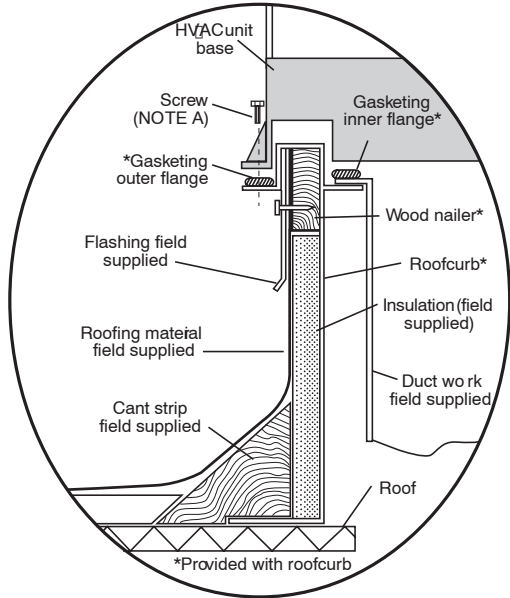

Roof Curb for Small Cabinet

Note A: When unit mounting screw is used, retainer bracket must also be used.

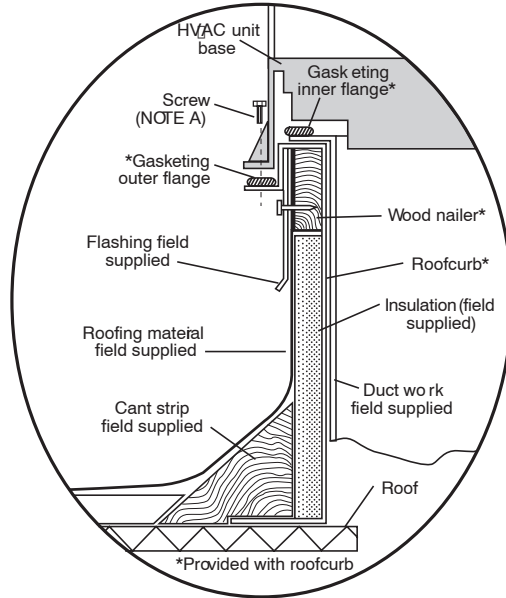

Roof Curb for Large Cabinet

Note A: When unit mounting screw is used, retainer bracket must also be used.

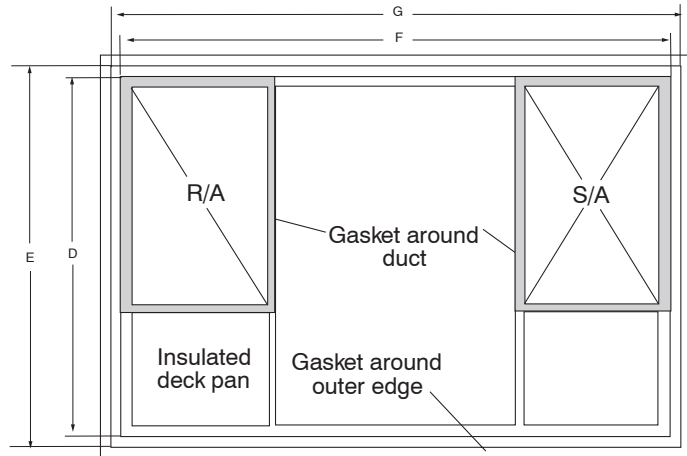
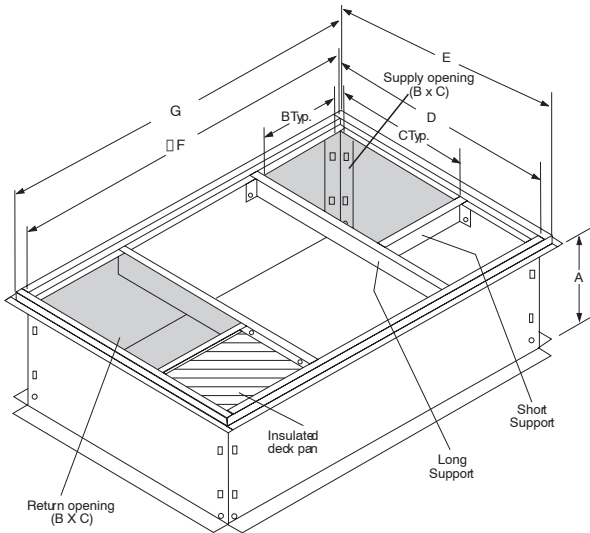

UNIT SIZE	MODEL NUMBER	A IN. [MM]	B IN. [MM]	C IN. [MM]	D IN. [MM]	E IN. [MM]	F IN. [MM]	G IN. [MM]
24	NPRFCURB006A00	8 [203]	11 [279]	16-1/2 [419]	28-3/4 [730]	30-3/8 [771]	44-5/16 [1126]	45-15/16 [1167]
	NPRFCURB007A00	14 [356]	11 [279]	16-1/2 [419]	28-3/4 [730]	30-3/8 [771]	44-5/16 [1126]	45-15/16 [1167]
36-60	NPRFCURB008A00	8 [203]	16-3/16 [411]	17-3/8 [441]	40-1/4 [1022]	41-15/16 [1065]	44-7/16 [1129]	46-1/16 [1169]
	NPRFCURB009A00	14 [356]	16-3/16 [411]	17-3/8 [441]	40-1/4 [1022]	41-15/16 [1065]	44-7/16 [1129]	46-1/16 [1169]

Notes:

1. Seal strip must be applied as required to unit being installed.
2. Roof curb is made of 16 gauge steel.
3. Attach ductwork to curb (flanges of duct rest on curb).
4. Insulated panels: 1-in. thick fiberglass 1 lb. density.
5. When unit mounting screw is used (see Note A), a retainer bracket must be used as well. This bracket must also be used when required by code for hurricane or seismic conditions. This bracket is available through Micrometl.

ACCESSORIES (continued)

MANUAL FRESH AIR DAMPERS (use in DOWNFLOW application only) *

Model Number	Control	Use With Model Size
NPMANDPR004A00	Manual	24
NPMANDPR005A00		36
NPMANDPR006A00		48, 60

* Unit must have internal filters to protect evaporator coil when Fresh Air Damper is installed.
All Manual Fresh Air Dampers shipped with Filter Racks but without Filters.

FILTER RACK and FILTER (shipped with 1" filters)

Model Number	Application	Filter Size	Use With Model Size
NPFILTRK004A00	Horizontal or Downflow	12" x 20" x 1" (quan. 2) or 12" x 20" x 2" (quan. 1) PLUS 10" x 20" x 2" (quan.1)	24
NPFILTRK005A00		12" x 24" x 1" or 2" (3 required)	36
NPFILTRK006A00		12" x 24" x 1" or 2" (3 required)	48, 60

CONCENTRIC ADAPTER

Model Number	Description	Use With Model Size
AXB030CTA	Adapts downflow openings thru the curb into round duct (18" dia.)	ALL

CONCENTRIC DIFFUSER

Model Number	Description	Use With Model Size
AXB030CSA	STEP DOWN - Adapts round duct (18" dia.) to ceiling diffuser	ALL
AXB030CFA	FLUSH MOUNT - Adapts round duct (18" dia.) to ceiling diffuser	ALL

SQUARE to ROUND TRANSITION

Model Number	Round Size	Square Size	Use With Model Size
NPDUFCFLG002A00	14"	14" x 16"	24, 36, 48

PTC COMPRESSOR START ASSIST KIT

Model Number	Description	Use With Model Size
NPHSTART001A00	PTC type compressor start assist	ALL

ANTI-CYCLE TIMER

Model Number	Description	Use With Model Size
NRTIMEGD001A00	5 minute anti-cycle timer (Note: many thermostats have inherent anti-cycle timer logic)	ALL

CRANKCASE HEATER (Factory installed on 36 and 60)

Model Number	Description	Use With Model Size
NPCRKHTR008A00	Belly-band type electric heater	24
NPCRKHTR004A00	Belly-band type electric heater	48

GAS CONVERSION KITS

Model Number	Description	Heat Input (BTU/h)	Elevation above Sea Level
NPLPCONV011A00	Natural Gas to Propane	40,000 - 130,000	0' - 2,000'
NPLPCONV012A00	Natural Gas to Propane		2,000' - 6000'
NPNGCONV003A00	Propane to Natural Gas	40,000 - 130,000	0' - 2,000'

FLUE DISCHARGE DEFLECTOR

Model Number	Description	Heat Input (BTU/h)	Use With Model Size
NRFLUEDS001A00	Vertical flue, spaced away from unit cabinet	40,000 - 130,000	ALL

LIFTING / RIGGING KIT

Model Number	Description	Use With Model Size
NPLIFTBK003A10	Lifting / Rigging Kit (Set of 10)	ALL

UNIT DIMENSIONS, model sizes 24

Unit	Electrical Characteristics	Unit Weight lbs. / KG.	Center of Gravity - mm [in]		
			A	X	Z
PGN524040	208/230-1-60	396 / 179.6	1041.9 [41.02]	508.0 [20.0]	489.0 [19.3]
PGN524060	208/230-1-60	401 / 181.9	1041.9 [41.02]	508.0 [20.0]	489.0 [19.3]

REQUIRED CLEARANCES TO COMBUSTIBLE MATL.

TOP OF UNIT..... 14.00 [555.6]
 DUCT SIDE OF UNIT..... 2.00 [50.8]
 SIDE OPPOSITE DUCTS..... 14.00 [555.6]
 BOTTOM OF UNIT..... 0.00 [0.0]
 FLUE PANEL..... 36.00 [1914.4]

NEC. REQUIRED CLEARANCES.

BETWEEN UNITS, POWER ENTRY SIDE..... 42.00 [1066.8]
 UNIT AND UNGROUNDED SURFACES, POWER ENTRY SIDE..... 36.00 [914.0]
 UNIT AND UNGROUNDED SURFACES, POWER ENTRY OTHER GROUNDED SURFACES, POWER ENTRY SIDE..... 42.00 [1066.8]

REQUIRED CLEARANCE FOR OPERATION AND SERVICING

EQUIP. COIL ACCESS SIDE..... 2.00 [50.8]
 POWER ENTRY SIDE..... 42.00 [1066.8]
 (EXCEPT FOR NEC REQUIREMENTS)

UNIT TOP..... 48.00 [1219.2]
 SIDE OPPOSITE DUCTS..... 36.00 [914.0]
 DUCT PANEL..... 12.00 [304.8]

*MINIMUM DISTANCES: IF UNIT IS PLACED LESS THAN 12.00 [304.8] FROM WALL SYSTEM, THEN SYSTEM PERFORMANCE MAYBE COMPROMISED.

DIMENSIONS IN [] ARE IN MILLIMETERS

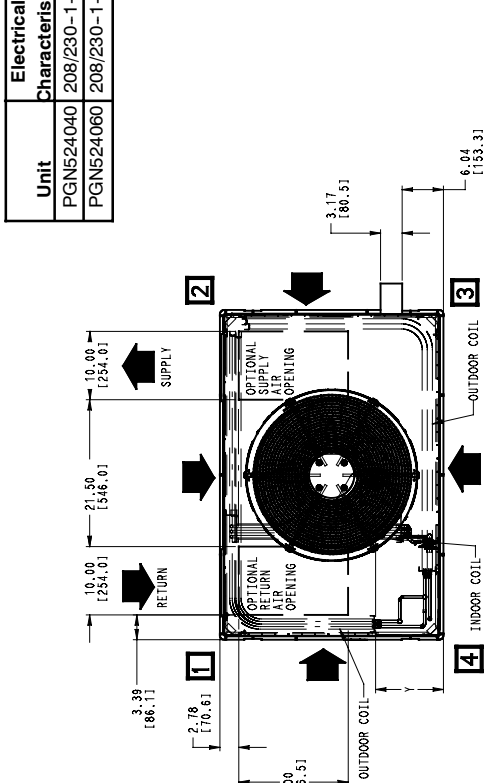

TOP VIEW

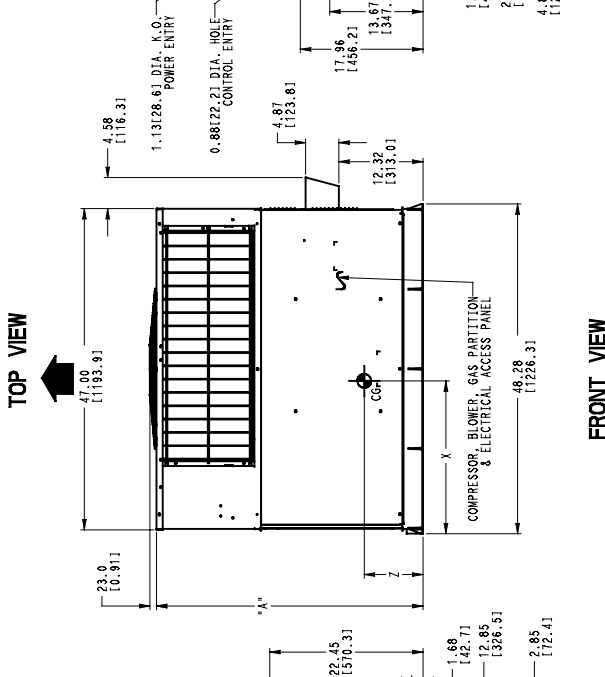

FRONT VIEW

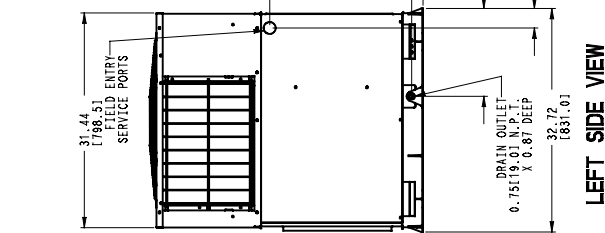

LEFT SIDE VIEW

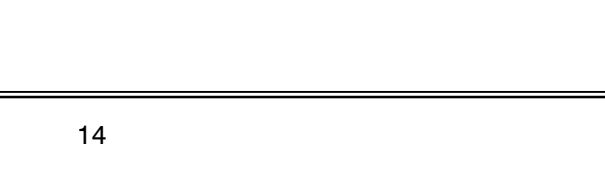

RIGHT SIDE VIEW



REAR VIEW

UNIT DIMENSIONS, model sizes 36, 48, 60

Unit	Electrical Characteristics	Unit Weight		Unit Height			Center of Gravity - mm [in]		
		lbs.	KG.	A	X	Y	Z		
PGN536060	208/230-1-60	485	220.0	1142.5 [44.98]	553.4 [21.0]	520.7 [20.5]	421.6 [16.6]		
PGN536090	208/230-1-60	493	223.6	1142.5 [44.98]	553.4 [21.0]	520.7 [20.5]	421.6 [16.6]		
PGN548090	208/230-1-60	521	236.3	1193.3 [46.98]	495.3 [19.5]	539.8 [21.3]	457.2 [18.0]		
PGN548115	208/230-1-60	521	236.3	1193.3 [46.98]	495.3 [19.5]	539.8 [21.3]	457.2 [18.0]		
PGN548190	208/230-1-60	521	236.3	1193.3 [46.98]	495.3 [19.5]	539.8 [21.3]	457.2 [18.0]		
PGN560090	208/230-1-60	572	259.5	1294.9 [50.98]	553.4 [21.0]	508.0 [20.0]	447.0 [17.6]		
PGN560115	208/230-1-60	572	259.5	1294.9 [50.98]	553.4 [21.0]	508.0 [20.0]	447.0 [17.6]		
PGN560190	208/230-1-60	572	259.5	1294.9 [50.98]	553.4 [21.0]	508.0 [20.0]	447.0 [17.6]		

REQUIRED CLEARANCES TO COMBUSTIBLE MATL.

INCHES [MM]
 TOP OF UNIT.....14.00 [355.6]
 DUCT SIDE OF UNIT.....2.00 [50.8]
 SIDE OPPOSITE DUCTS.....4.00 [101.6]
 BOTTOM OF UNIT.....36.00 [914.4]
 FLUE PANEL.....36.00 [914.4]

NEC. REQUIRED CLEARANCES.
 INCHES [MM]
 BETWEEN UNITS, POWER ENTRY SIDE.....42.00 [1066.8]
 UNIT AND BLOWERS, COMPRESSOR, GAS SECTION, ELECTRICAL ACCESS SIDE.....36.00 [914.4]
 UNIT AND BLOWERS, COMPRESSOR, GAS SECTION, ELECTRICAL ACCESS OTHER GROUNDED SURFACES, POWER ENTRY SIDE.....42.00 [1066.8]

REQUIRED CLEARANCE FOR OPERATION AND SERVICING
 INCHES [MM]
 FWR. COIL ACCESS SIDE.....42.00 [1066.8]
 POWER ENTRY SIDE.....42.00 [1066.8]
 (EXCEPT FOR NEC REQUIREMENTS)
 UNIT TOP.....48.00 [1219.2]
 SIDE OPPOSITE DUCTS.....36.00 [914.4]
 DUCT PANEL.....12.00 [304.8]

*MINIMUM DISTANCES: IF UNIT IS PLACED LESS THAN 12.00 [304.8] FROM WALL SYSTEM, THEN SYSTEM PERFORMANCE MAYBE COMPROMISED.

DIMENSIONS IN [] ARE IN MILLIMETERS

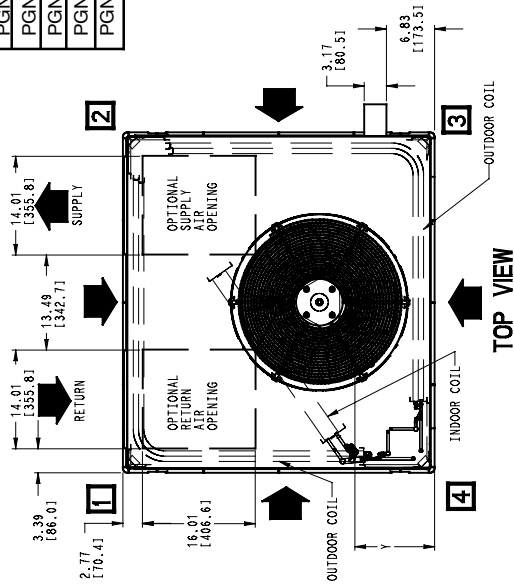

TOP VIEW

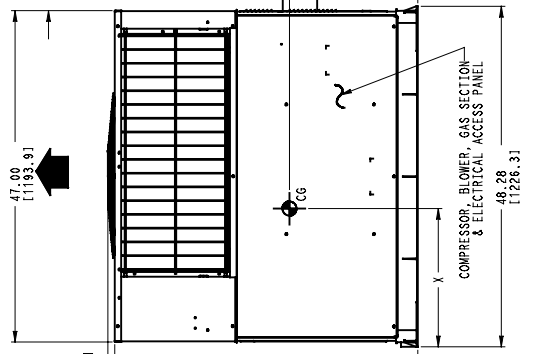

FRONT VIEW

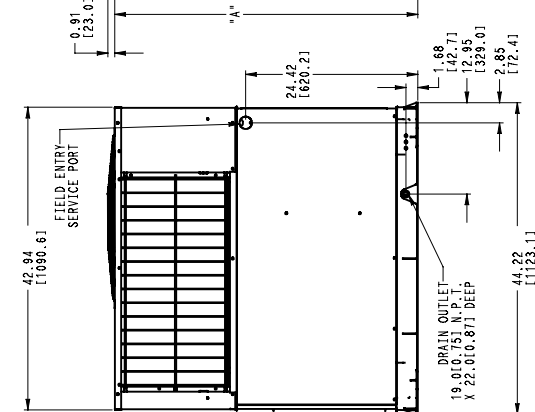

LEFT SIDE VIEW

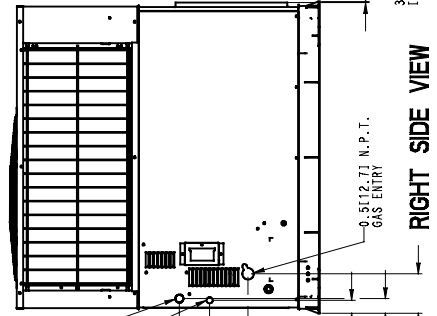

RIGHT SIDE VIEW

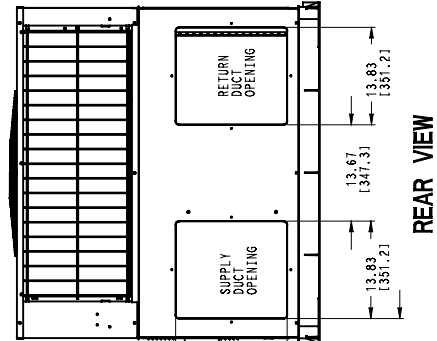

REAR VIEW

GUIDE SPECIFICATIONS

CABINET

Unit cabinet shall be constructed of phosphated, zinc-coated, pre-painted steel capable of with-standing 500 hours in salt spray. Normal service shall be through a single removable cabinet panel. The unit shall be constructed on a rust proof unit base that has an externally trapped, integrated sloped drain.

Evaporator fan compartment top surface shall be insulated with a minimum 1/2-in. thick, flexible fiberglass insulation, coated on the air side and retained by adhesive and mechanical means. The evaporator wall sections will be insulated with a minimum semi-rigid foil-faced board capable of being wiped clean. Aluminum foil-faced fiberglass insulation shall be used in the entire indoor air cavity section.

COOLING SECTION

The unit is factory charged and operationally ready upon delivery. The unit refrigerant circuit has a high efficiency scroll compressor with internal overload protection, and copper tube / aluminum fin evaporator and condenser coils. The unit is designed for cooling operation to 40° F and will be capable of being wired for field installed economizer type accessories.

COILS

The evaporator and condenser coils are fabricated with aluminum fins mechanically bonded to copper tubing. Both coils are pressure tested prior to assembly into the unit and electronically leak tested after assembly into the unit.

CONDENSER FAN

The unit has a single direct-drive propeller-fan / motor assembly. The assembly is mounted directly to a vertical-discharge grille that is easily removed for service. Motors are 825 - 1100 RPM with sleeve or ball bearings and internal overload protection.

EVAPORATOR BLOWER

All units have a direct-drive X-13 evaporator blower motor as a standard. The direct-drive evaporator blower motor has sleeve bearings and internal overload protection.

HEATING SECTION

The gas-fired heating section features an induced draft blower for combustion air. The unit has an tubular aluminized steel heat exchanger located on the discharge air side of the blower. The system uses in-shot burners ignited by a direct spark ignition system, protected by both a high heat limit switch and flame roll-out switch. The induced draft blower motor is interlocked with a pressure switch safety device.

CORNER WEIGHTS and RIGGING DETAILS

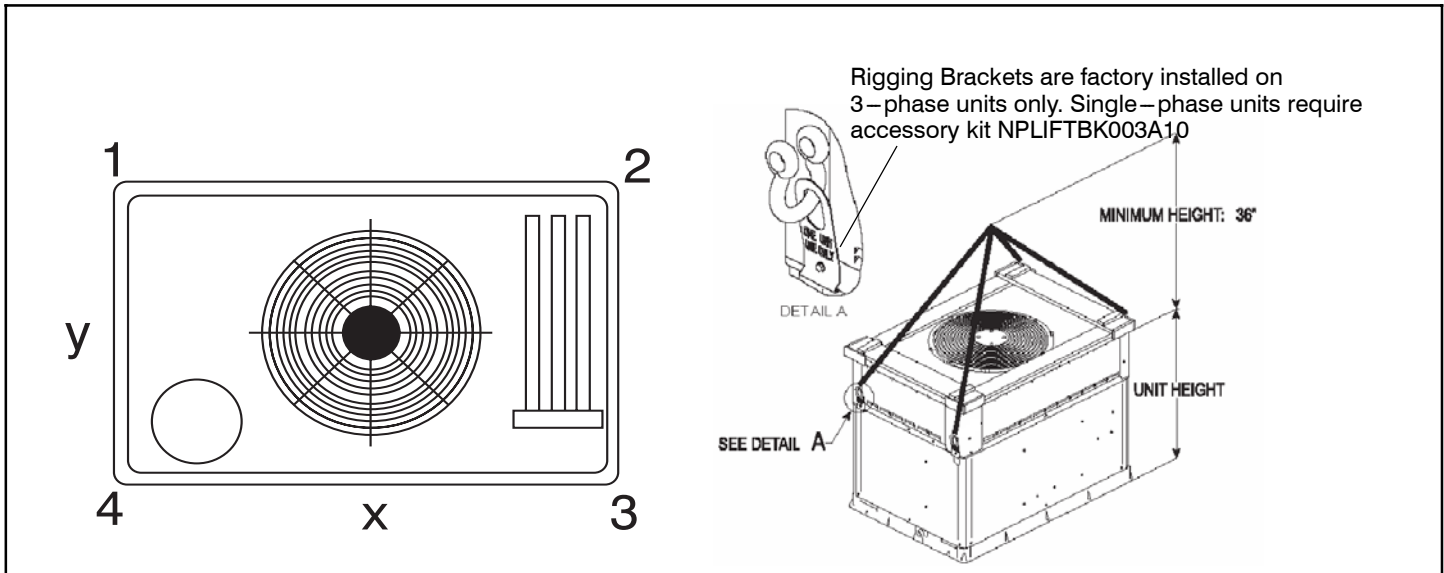

CORNER WEIGHTS

Unit Model	Unit Only Weight		Corner Weight 1		Corner Weight 2		Corner Weight 3		Corner Weight 4		Rigging Weight		Shipping Weight	
	lbs	kg	lbs	kg	lbs	kg	lbs	kg	lbs	kg	lbs	kg	lbs	kg
PGN524040	396	179.6	85	38.6	85	38.6	79	35.8	147	66.7	415	188.2	450	204.1
PGN524060	401	181.9	86	39.0	86	39.0	80	36.3	148	67.1	420	190.5	455	206.4
PGN536060	485	220.0	100	45.4	112	50.8	91	41.3	182	82.6	507	230.0	547	248.1
PGN536090	493	223.6	101	45.8	114	51.7	92	41.7	185	83.9	515	233.6	555	251.7
PGN548090	521	236.2	115	52.2	86	39.0	138	62.6	182	82.6	543	246.3	583	264.4
PGN548115	521	236.2	115	52.2	86	39.0	138	62.6	182	82.6	543	246.3	583	264.4
PGN548130	521	236.2	115	52.2	86	39.0	138	62.6	182	82.6	543	246.3	583	264.4
PGN560090	572	259.5	126	57.2	91	41.3	153	69.4	202	91.6	594	269.4	634	287.6
PGN560115	572	259.5	126	57.2	91	41.3	153	69.4	202	91.6	594	269.4	634	287.6
PGN560130	572	259.5	126	57.2	91	41.3	153	69.4	202	91.6	594	269.4	634	287.6

MODEL NOMENCLATURE										
MODEL SERIES	P	G	N	5	36	090	K	00	A	1
P = Package										
G = Gas/Electric										
N = R-410A										
5 = 15				SEER						
24 = 24,000 BTUH = 2 Tons										
36 = 36,000 BTUH = 3 Tons										
48 = 48,000 BTUH = 4 Tons										
60 = 60,000 BTUH = 5 Tons										
040 = 40,000										
060 = 60,000										
090 = 90,000										
115 = 115,000										
130 = 130,000										
K = 208/230-1-60										
00 = Standard										
01 = Low NOx										
Sales Model Digit										
Engineering Digit										