



PGD3 – “TP”

Product Specifications

13 SEER PACKAGE GAS / ELECTRIC UNIT, 2 to 5 TONS

Single Phase, 208/230 V, 60 Hz

REFRIGERATION CIRCUIT

- Tin-coated copper evaporator coil standard
- Environmentally sound R-410A refrigerant
- Scroll compressor standard on all models
- Copper tube/aluminum fin condenser
- Dehumidification mode (airflow reduction) on all models

EASY TO INSTALL AND SERVICE

- Installs easily on a rooftop or at ground level
- Easy three-panel accessibility for maintenance and installation
- Easily converts to down discharge applications
- Combination gas heating and electric cooling

BUILT TO LAST

- Pre-painted steel cabinet
- Direct spark ignition
- High efficiency ECM indoor blower motor on all models
- Aluminized steel tubular heat exchanger
- Full perimeter steel base rails
- High and low pressure switches provide added reliability for the compressor

WARRANTY*

- 10 year heat exchanger limited warranty
- 5 year parts limited warranty (including compressor and coils)
 - With timely registration, an additional 5 year parts limited warranty (including compressor and coils)

*Applies to original purchaser/homeowner, some limitations may apply. See warranty certificate for complete details.



Use of the AHRI Certified TM Mark indicates a manufacturer's participation in the program. For verification of certification for individual products, go to www.ahridirectory.org.



UNIT PERFORMANCE DATA							
Model Number	COOLING			HEATING		Unit Dimensions Height x Width x Depth in (mm)	Operating Weight lbs (kg)
	Capacity BTU/h	SEER	EER	Input BTU/h	Efficiency AFUE %		
PGD324040KTP0C	23,000	13.2	11.0	40,000	80.0	40x48 ³ / ₁₆ x32 ⁵ / ₈ (1016x1224x829)	304 (137)
PGD324060KTP0C	23,000	13.2	11.0	60,000	80.0	40x48 ³ / ₁₆ x32 ⁵ / ₈ (1016x1224x829)	304 (137)
PGD330040KTP0C	28,600	13.5	11.2	40,000	80.0	42x48 ³ / ₁₆ x32 ⁵ / ₈ (1066x1224x829)	309 (140)
PGD330060KTP0C	28,600	13.5	11.2	60,000	80.0	42x48 ³ / ₁₆ x32 ⁵ / ₈ (1066x1224x829)	309 (140)
PGD336060KTP0C	34,400	13.0	11.0	60,000	80.0	46x48 ³ / ₁₆ x32 ⁵ / ₈ (1168x1224x829)	319 (144)
PGD336090KTP0C	34,400	13.0	11.0	90,000	79.3	46x48 ³ / ₁₆ x32 ⁵ / ₈ (1168x1224x829)	319 (144)
PGD342060KTP0C	40,500	13.2	11.2	60,000	78.5	40x48 ³ / ₁₆ x44 ¹ / ₈ (1016x1224x1123)	411 (186)
PGD342090KTP0C	40,500	13.2	11.2	90,000	80.4	40x48 ³ / ₁₆ x44 ¹ / ₈ (1016x1224x1123)	411 (186)
PGD348090KTP0C	46,500	13.2	11.2	90,000	80.4	42x48 ³ / ₁₆ x44 ¹ / ₈ (1066x1224x1123)	419 (190)
PGD348115KTP0C	46,500	13.2	11.2	115,000	80.3	42x48 ³ / ₁₆ x44 ¹ / ₈ (1066x1224x1123)	419 (190)
PGD348130KTP0C	46,500	13.2	11.2	130,000	78.9	42x48 ³ / ₁₆ x44 ¹ / ₈ (1066x1224x1123)	419 (190)
PGD360090KTP0C	57,000	13.4	11.0	90,000	80.4	42x48 ³ / ₁₆ x44 ¹ / ₈ (1066x1224x1123)	419 (190)
PGD360115KTP0C	57,000	13.4	11.0	115,000	80.3	42x48 ³ / ₁₆ x44 ¹ / ₈ (1066x1224x1123)	441 (200)
PGD360130KTP0C	57,000	13.4	11.0	130,000	78.9	42x48 ³ / ₁₆ x44 ¹ / ₈ (1066x1224x1123)	441 (200)

MODEL NOMENCLATURE											
MODEL SERIES	1	2	3	4	5,6	7,8,9	10	11,12	13	14	15
	P	G	D	3	36	090	K	TP	0	C	1
P = Package											
G = Gas/Electric											
D = Standard											
3 = 13											
24 = 24,000 BTUH = 2 Tons											
30 = 30,000 BTUH = 2.5 Tons											
36 = 36,000 BTUH = 3 Tons											
42 = 42,000 BTUH = 3.5 Tons											
48 = 48,000 BTUH = 4 Tons											
60 = 60,000 BTUH = 5 Tons											
000 = no factory heat											
040 = 40,000 BTU/hr											
060 = 60,000 BTU/hr											
090 = 90,000 BTU/hr											
115 = 115,000 BTU/hr											
130 = 130,000 BTU/hr											
K = 208/230-1-60											
TP = Tin Plated Evaporator Main Tubes											
0 = Standard											
Sales Model Digit											
Engineering Digit											

AHRI* CAPACITIES

COOLING CAPACITIES AND EFFICIENCIES					
UNIT PGD3	NOMINAL TONS	STANDARD CFM	NET COOLING CAPACITIES (Btuh)	EER**	SEER†
24	2	800	23,000	11.0	13.2
30	2-1/2	1000	28,400	11.2	13.5
36	3	1200	34,400	11.0	13.0
42	3-1/2	1400	40,500	11.2	13.2
48	4	1600	46,500	11.2	13.2
60	5	1750	57,000	11.0	13.4

LEGEND

dB—Sound Levels (decibels)

db—Dry Bulb

SEER—Seasonal Energy Efficiency Ratio

wb—Wet Bulb

COP—Coefficient of Performance

* Air Conditioning, Heating, & Refrigeration Institute.

**At "A" conditions—80°F (26.7°C) indoor db/67°F (19.4°C) indoor wb & 95°F (35°C) outdoor db.

† Rated in accordance with U.S. Government DOE Department of Energy) test procedures and/or AHRI Standards 210/240.

Notes:

1. Ratings are net values, reflecting the effects of circulating fan heat.

Ratings are based on:

Cooling Standard: 80°F (26.7°C) db, 67°F wb (19.4°C) indoor entering—air temperature and 95°F db (35°C) outdoor entering—air temperature.

2. Before purchasing this appliance, read important energy cost and efficiency information available from your retailer.

GAS HEATING CAPACITIES AND EFFICIENCIES

PGD3	HEATING INPUT (Btuh)	OUTPUT CAPACITY (Btuh)	TEMPERATURE RISE RANGE °F (°C)	AFUE (%)
24040 30040	40,000	32,000	30-60 (16.7-33.3)	80.0
24060 30060 36060 42060	60,000	48,000 48,000 48,000 47,000	25-55 (13.9-30.6)	80.0 80.0 80.0 78.5
36090 42090 48090 60090	90,000	72,000 73,000 73,000 73,000	35-65 (19.4-36.1)	79.3 80.4 80.4 80.4
48115 60115	115,000	93,000	30-60 (16.7-33.3)	80.3
48130 60130	130,000	103,000	35-65 (19.4-36.1)	78.9

LEGEND

AFUE—Annual Fuel Utilization Efficiency

NOTE: Before purchasing this appliance, read important energy cost and efficiency information available from your retailer.

UNIT ELECTRICAL SPECIFICATIONS

MODEL NUMBER	Voltage Range		Compressor		OFM	IFM	IDM	Power Supply	
	Min.	Max.	RLA	LRA	FLA	FLA	FLA	MCA	MOCP
PGD324040	187	253	12.8	58.3	1.2	4.1	0.7	21.3	30.
PGD324060			12.8	58.3	1.2	4.1	1.7	21.3	30.
PGD330040			12.8	64.0	1.2	4.1	0.7	21.3	30.
PGD330060			12.8	64.0	1.2	4.1	1.7	21.3	30.
PGD336060			16.7	79.0	1.2	6.0	1.7	28.0	40.
PGD336090			16.7	79.0	1.2	6.0	0.5	28.0	40.
PGD342060			17.9	112.0	1.2	6.0	1.7	29.6	40.
PGD342090			17.9	112.0	1.2	6.0	0.7	29.6	40.
PGD348090			21.8	117.0	1.2	7.6	0.7	36.0	50.
PGD348115			21.8	117.0	1.2	7.6	1.7	36.0	50.
PGD348130			21.8	117.0	1.2	7.6	0.5	36.0	50.
PGD360090			26.4	134.0	1.2	7.6	0.7	41.8	60.
PGD360115			26.4	134.0	1.2	7.6	1.7	41.8	60.
PGD360130			26.4	134.0	1.2	7.6	0.5	41.8	60.

** FUSE OR CIRCUIT BREAKER

LEGEND

- FLA = Full Load Amps
- LRA = Locked Rotor Amps
- MCA = Minimum Circuit Ampacity
- MOCP = Maximum Overcurrent Protection
- RLA = Rated Load Amps

1. In compliance with NEC (National Electrical Code) requirements for multimotor and combination load equipment (refer to NEC Articles 430 and 440), the overcurrent protective device for the unit shall be Power Supply fuse. The CGA (Canadian Gas Association) units may be fuse or circuit breaker.

2. Minimum wire size is based on 60 C copper wire. If other than 60 C wire is used, or if length exceeds wire length in table, determine size from NEC.



UNIT SPECIFICATIONS PGD324 – 42									
UNIT SIZE	24040	24060	30040	30060	36060	36090	42060	42090	
NOMINAL COOLING CAPACITY (ton)	2	2	2-1/2	2-1/2	3	3	3-1/2	3-1/2	
NOMINAL HEATING INPUT (Btu/hrs)	40,000	60,000	40,000	60,000	60,000	90,000	60,000	90,000	
SHIPPING WEIGHT** lb.	311	311	316	316	326	326	420	420	
SHIPPING WEIGHT** (kg)	141	141	143	143	148	148	191	191	
COMPRESSORS	Scroll								
Quantity	1								
REFRIGERANT (R-410A)									
Quantity lb.	4.8	4.8	6.2	6.2	6.4	6.4	6.1	6.1	
Quantity (kg)	2.2	2.2	2.8	2.8	2.9	2.9	2.7	2.7	
REFRIGERANT METERING DEVICE	TXV								
OUTDOOR COIL									
Rows...Fins/in.	1...21	1...21	1...21	1...21	1...21	1...21	1...21	1...21	
Face Area (sq ft)	10.2	10.2	11.9	11.9	15.4	15.4	13.6	13.6	
OUTDOOR FAN									
Nominal CFM	2800	2800	3000	3000	3200	3200	3600	3600	
Diameter in.	24	24	24	24	24	24	26	26	
Diameter (mm)	609.6	609.6	609.6	609.6	609.6	609.6	660.4	660.4	
Motor Hp (Rpm)	1/5 (810)	1/5 (810)	1/5 (810)	1/5 (810)	1/5 (810)	1/5 (810)	1/5 (810)	1/5 (810)	
INDOOR COIL									
Rows...Fins/in.	2...17	2...17	3...17	3...17	3...17	3...17	3...17	3...17	
Face Area (sq ft)	3.7	3.7	3.7	3.7	3.7	3.7	4.7	4.7	
INDOOR BLOWER									
Nominal Cooling Airflow (Cfm)	800	800	1000	1000	1200	1200	1400	1400	
Size in.	10x10	10x10	10x10	10x10	11x10	11x10	11x10	11x10	
Size (mm.)	254x254	254x254	254x254	254x254	279.4x254	279.4x254	279.4x254	279.4x254	
Motor HP (RPM)	1/2 (1050)	1/2 (1050)	1/2 (1050)	1/2 (1050)	3/4 (1000)	3/4 (1000)	3/4 (1075)	3/4 (1075)	
FURNACE SECTION*									
Burner Orifice No. (Qty...Drill Size)									
Natural Gas Factory Installed	2...44	2...38	2...44	2...38	2...38	3...38	2...38	3...38	
Propane Gas	2...55	2...53	2...55	2...53	2...53	3...53	2...53	3...53	
HIGH-PRESSURE SWITCH (psig)	Cut-out (Auto) 650 +/- 15 Reset (Auto) 420 +/- 25								
LOSS-OF-CHARGE / LOW-PRESSURE SWITCH (Liquid Line) (psig)	Cut-out (Auto) 20 +/- 5 Reset (Auto) 45 +/- 10								
RETURN-AIR FILTERS†‡									
Throwaway Size in. (mm)	20x20x1 508x508x25	20x24x1 508x610x25				24x30x1 610x762x25			

UNIT SPECIFICATIONS PGD348 – 60								
UNIT SIZE	48090	48115	48130	60090	60115	60130		
NOMINAL CAPACITY (ton)	4	4	4	5	5	5		
NOMINAL HEATING INPUT (Btu/hrs)	90,000	115,000	130,000	90,000	115,000	130,000		
SHIPPING WEIGHT** lb	428	428	428	450	450	450		
SHIPPING WEIGHT** kg	194	194	194	204	204	204		
COMPRESSORS	Scroll							
Quantity	1							
REFRIGERANT (R-410A)								
Quantity lb	6.4	6.4	6.4	10.0	10.0	10.0		
Quantity (kg.)	2.9	2.9	2.9	4.5	4.5	4.5		
REFRIGERANT METERING DEVICE	TXV							
OUTDOOR COIL								
Rows...Fins/in.	1...21	1...21	1...21	2...21	2...21	2...21		
Face Area (sq ft)	15.5	15.5	15.5	15.5	15.5	15.5		
OUTDOOR FAN								
Nominal Cfm	4000	4000	4000	3200	3200	3200		
Diameter in.	26	26	26	26	26	26		
Diameter (mm)	660.4	660.4	660.4	660.4	660.4	660.4		
Motor Hp (Rpm)	1/5 (810)	1/5 (810)	1/5 (810)	1/5 (810)	1/5 (810)	1/5 (810)		
INDOOR COIL								
Rows...Fins/in.	3...17	3...17	3...17	3...17	3...17	3...17		
Face Area (sq ft)	4.7	4.7	4.7	5.7	5.7	5.7		
INDOOR BLOWER								
Nominal Cooling Airflow (Cfm)	1600	1600	1600	1750	1750	1750		
Size in.	11x10	11x10	11x10	11x10	11x10	11x10		
Size (mm)	279.4x254	279.4x254	279.4x254	279.4x254	279.4x254	279.4x254		
Motor HP (RPM)	1.0 (1075)	1.0 (1075)	1.0 (1075)	1.0 (1040)	1.0 (1040)	1.0 (1040)		
FURNACE SECTION*								
Burner Orifice No.								
Natural Gas Qty...Drill Size (Factory Installed)	3...38	3...33	3...31	3...38	3...33	3...31		
Propane Gas	3...53	3...51	3...49	3...53	3...51	3...49		
HIGH-PRESSURE SWITCH (psig)	Cut-out (Auto) 650 +/- 15 Reset (Auto) 420 +/- 25							
LOSS-OF-CHARGE / LOW-PRESSURE SWITCH (Liquid Line) (psig)	Cut-out (Auto) 20 +/- 5 Reset (Auto) 45 +/- 10							
RETURN-AIR FILTERS †‡ in. (mm)	24x36x1 610x914x25							

*Based on altitude of 0 to 2000 ft (0–610 m).

† Required filter sizes shown are based on the larger of the AHRI (Air Conditioning, Heating, and Refrigeration Institute) rated cooling airflow or the heating airflow velocity of 300 ft/minute for throwaway type. Air filter pressure drop for non-standard filters must not exceed 0.08 IN. W.C.

‡ If using accessory filter rack refer to the filter rack installation instructions for correct filter sizes and quantity.

UNIT AIRFLOW, Horizontal and Downflow Discharge, 230 Volts, Dry Coil

Unit PGD3	Heating Rise Range °F (°C)	Motor Speed	Wire Color		External Static Pressure (in wc)								
					0.1	0.2	0.3	0.4	0.5	0.6	0.7	0.8	0.9
24040	30 – 60 (17 – 33)	Low	Blue	CFM	754	650	538	429	--	--	--	--	--
				Heating Rise (°F)	40	46	56	NA	NA	NA	NA	NA	NA
				Heating Rise (°C)	22	26	31	NA	NA	NA	NA	NA	NA
		Med-Low	Pink	CFM	851	777	675	591	475	--	--	--	--
				Heating Rise (°F)	36	39	45	51	NA	NA	NA	NA	NA
				Heating Rise (°C)	20	22	25	28	NA	NA	NA	NA	NA
		Medium ²	Red	CFM	941	851	774	684	576	479	--	--	--
				Heating Rise (°F)	32	36	39	44	52	NA	NA	NA	NA
				Heating Rise (°C)	18	20	22	25	29	NA	NA	NA	NA
		Med-High ¹	Orange	CFM	1009	917	840	759	667	577	447	--	--
				Heating Rise (°F)	30	33	36	40	45	52	NA	NA	NA
				Heating Rise (°C)	17	18	20	22	25	29	NA	NA	NA
High	Black	CFM	1241	1167	1111	1036	969	881	818	731	640		
		Heating Rise (°F)	NA	NA	NA	NA	31	34	37	41	47		
		Heating Rise (°C)	NA	NA	NA	NA	17	19	21	23	26		
24060	25 – 55 (14 – 31)	Low	Blue	CFM	754	650	538	429	--	--	--	--	--
				Heating Rise (°F)	NA	NA	NA	NA	NA	NA	NA	NA	NA
				Heating Rise (°C)	NA	NA	NA	NA	NA	NA	NA	NA	NA
		Med-Low	Pink	CFM	851	777	675	591	475	--	--	--	--
				Heating Rise (°F)	52	NA	NA	NA	NA	NA	NA	NA	NA
				Heating Rise (°C)	29	NA	NA	NA	NA	NA	NA	NA	NA
		Medium ²	Red	CFM	941	851	774	684	576	479	--	--	--
				Heating Rise (°F)	47	52	NA	NA	NA	NA	NA	NA	NA
				Heating Rise (°C)	26	29	NA	NA	NA	NA	NA	NA	NA
		Med-High	Orange	CFM	1009	917	840	759	667	577	447	--	--
				Heating Rise (°F)	44	48	53	NA	NA	NA	NA	NA	NA
				Heating Rise (°C)	24	27	29	NA	NA	NA	NA	NA	NA
High ¹	Black	CFM	1241	1167	1111	1036	969	881	818	731	640		
		Heating Rise (°F)	36	38	40	43	46	50	54	NA	NA		
		Heating Rise (°C)	20	21	22	24	25	28	30	NA	NA		
30040	30 – 60 (17 – 33)	Low	Blue	CFM	741	638	547	415	--	--	--	--	--
				Heating Rise (°F)	41	47	55	NA	NA	NA	NA	NA	NA
				Heating Rise (°C)	23	26	31	NA	NA	NA	NA	NA	NA
		Med-Low ¹	Pink	CFM	973	887	823	733	665	538	451	--	--
				Heating Rise (°F)	31	34	37	41	45	56	NA	NA	NA
				Heating Rise (°C)	17	19	20	23	25	31	NA	NA	NA
		Medium	Red	CFM	1088	1023	954	881	800	723	658	563	461
				Heating Rise (°F)	NA	30	32	34	38	42	46	54	NA
				Heating Rise (°C)	NA	16	18	19	21	23	26	30	NA
		Med-High ²	Orange	CFM	1140	1064	996	915	840	758	687	564	480
				Heating Rise (°F)	NA	NA	30	33	36	40	44	54	NA
				Heating Rise (°C)	NA	NA	17	18	20	22	24	30	NA
High	Black	CFM	1202	1140	1082	1015	961	881	810	732	631		
		Heating Rise (°F)	NA	NA	NA	30	31	34	37	41	48		
		Heating Rise (°C)	NA	NA	NA	17	17	19	21	23	27		
30060	25 – 55 (14 – 31)	Low	Blue	CFM	741	638	547	415	--	--	--	--	--
				Heating Rise (°F)	NA	NA	NA	NA	NA	NA	NA	NA	NA
				Heating Rise (°C)	NA	NA	NA	NA	NA	NA	NA	NA	NA
		Med-Low	Pink	CFM	973	887	823	733	665	538	451	--	--
				Heating Rise (°F)	46	50	54	NA	NA	NA	NA	NA	NA
				Heating Rise (°C)	25	28	30	NA	NA	NA	NA	NA	NA
		Medium	Red	CFM	1088	1023	954	881	800	723	658	563	461
				Heating Rise (°F)	41	43	47	50	NA	NA	NA	NA	NA
				Heating Rise (°C)	23	24	26	28	NA	NA	NA	NA	NA
		Med-High ²	Orange	CFM	1140	1064	996	915	840	758	687	564	480
				Heating Rise (°F)	39	42	45	49	53	NA	NA	NA	NA
				Heating Rise (°C)	22	23	25	27	29	NA	NA	NA	NA
High ¹	Black	CFM	1202	1140	1082	1015	961	881	810	732	631		
		Heating Rise (°F)	37	39	41	44	46	50	55	NA	NA		
		Heating Rise (°C)	21	22	23	24	26	28	30	NA	NA		

See Legend and Notes following tables.

UNIT AIRFLOW, Horizontal and Downflow Discharge, 230 Volts, Dry Coil

Unit PGD3	Heating Rise Range °F (°C)	Motor Speed	Wire Color	External Static Pressure (in wc)									
				0.1	0.2	0.3	0.4	0.5	0.6	0.7	0.8	0.9	
36060	25 – 55 (14 – 31)	Low ¹	Blue	CFM	1234	1168	1093	1021	961	894	825	759	687
				Heating Rise (°F)	36	38	41	44	46	50	54	NA	NA
				Heating Rise (°C)	20	21	23	24	26	28	30	NA	NA
		Med-Low	Pink	CFM	1290	1223	1154	1090	1027	977	894	828	762
				Heating Rise (°F)	34	36	39	41	43	45	50	54	NA
				Heating Rise (°C)	19	20	21	23	24	25	28	30	NA
		Medium ²	Red	CFM	1354	1290	1226	1158	1102	1046	981	918	843
				Heating Rise (°F)	33	34	36	38	40	42	45	48	53
				Heating Rise (°C)	18	19	20	21	22	24	25	27	29
		Med-High	Orange	CFM	1606	1546	1489	1430	1371	1316	1258	1208	1140
				Heating Rise (°F)	28	29	30	31	32	34	35	37	39
				Heating Rise (°C)	15	16	17	17	18	19	20	20	22
		High	Black	CFM	1630	1580	1517	1463	1407	1339	1277	1210	1131
				Heating Rise (°F)	27	28	29	30	32	33	35	37	39
				Heating Rise (°C)	15	16	16	17	18	18	19	20	22
36090	35 – 65 (19 – 36)	Low	Blue	CFM	1234	1168	1093	1021	961	894	825	759	687
				Heating Rise (°F)	55	58	62	NA	NA	NA	NA	NA	NA
				Heating Rise (°C)	31	32	35	NA	NA	NA	NA	NA	NA
		Med-Low	Pink	CFM	1290	1223	1154	1090	1027	977	894	828	762
				Heating Rise (°F)	53	56	59	62	NA	NA	NA	NA	NA
				Heating Rise (°C)	29	31	33	35	NA	NA	NA	NA	NA
		Medium ²	Red	CFM	1354	1290	1226	1158	1102	1046	981	918	843
				Heating Rise (°F)	50	53	55	59	62	65	NA	NA	NA
				Heating Rise (°C)	28	29	31	33	34	36	NA	NA	NA
		Med-High	Orange	CFM	1606	1546	1489	1430	1371	1316	1258	1208	1140
				Heating Rise (°F)	42	44	46	48	50	52	54	56	60
				Heating Rise (°C)	24	24	25	26	28	29	30	31	33
		High ¹	Black	CFM	1630	1580	1517	1463	1407	1339	1277	1210	1131
				Heating Rise (°F)	42	43	45	46	48	51	53	56	60
				Heating Rise (°C)	23	24	25	26	27	28	30	31	33
42060	25 – 55 (14 – 31)	Low ¹	Blue	CFM	1295	1234	1182	1126	1075	1016	955	898	857
				Heating Rise (°F)	34	36	38	39	41	44	47	49	52
				Heating Rise (°C)	19	20	21	22	23	24	26	27	29
		Med-Low	Pink	CFM	1345	1282	1235	1194	1140	1095	1027	974	921
				Heating Rise (°F)	33	35	36	37	39	41	43	46	48
				Heating Rise (°C)	18	19	20	21	22	23	24	25	27
		Medium	Red	CFM	1505	1452	1413	1358	1323	1282	1234	1169	1130
				Heating Rise (°F)	30	31	31	33	34	35	36	38	39
				Heating Rise (°C)	16	17	17	18	19	19	20	21	22
		Med-High ²	Orange	CFM	1545	1492	1449	1411	1362	1313	1278	1231	1188
				Heating Rise (°F)	29	30	31	31	33	34	35	36	37
				Heating Rise (°C)	16	17	17	17	18	19	19	20	21
		High	Black	CFM	1705	1643	1607	1568	1518	1483	1448	1404	1360
				Heating Rise (°F)	26	27	28	28	29	30	31	32	33
				Heating Rise (°C)	14	15	15	16	16	17	17	18	18
42090	35 – 65 (19 – 36)	Low	Blue	CFM	1295	1234	1182	1126	1075	1016	955	898	857
				Heating Rise (°F)	53	55	58	60	63	NA	NA	NA	NA
				Heating Rise (°C)	29	31	32	34	35	NA	NA	NA	NA
		Med-Low	Pink	CFM	1345	1282	1235	1194	1140	1095	1027	974	921
				Heating Rise (°F)	51	53	55	57	60	62	NA	NA	NA
				Heating Rise (°C)	28	29	31	32	33	35	NA	NA	NA
		Medium ¹	Red	CFM	1505	1452	1413	1358	1323	1282	1234	1169	1130
				Heating Rise (°F)	45	47	48	50	51	53	55	58	60
				Heating Rise (°C)	25	26	27	28	29	29	31	32	33
		Med-High ²	Orange	CFM	1545	1492	1449	1411	1362	1313	1278	1231	1188
				Heating Rise (°F)	44	46	47	48	50	52	53	55	57
				Heating Rise (°C)	24	25	26	27	28	29	30	31	32
		High	Black	CFM	1705	1643	1607	1568	1518	1483	1448	1404	1360
				Heating Rise (°F)	40	41	42	43	45	46	47	48	50
				Heating Rise (°C)	22	23	24	24	25	25	26	27	28

See Legend and Notes following tables.

UNIT AIRFLOW, Horizontal and Downflow Discharge, 230 Volts, Dry Coil

Unit PGD3	Heating Rise Range °F (°C)	Motor Speed	Wire Color	External Static Pressure (in wc)									
				0.1	0.2	0.3	0.4	0.5	0.6	0.7	0.8	0.9	
48090	35 – 65 (19 – 36)	Low ¹	Blue	CFM	1402	1351	1311	1263	1224	1172	1136	1080	1041
				Heating Rise (°F)	49	50	52	54	56	58	60	63	65
				Heating Rise (°C)	27	28	29	30	31	32	33	35	36
		Med-Low	Pink	CFM	1457	1404	1367	1318	1284	1233	1197	1144	1104
				Heating Rise (°F)	47	48	50	52	53	55	57	59	62
				Heating Rise (°C)	26	27	28	29	29	31	32	33	34
		Medium ²	Red	CFM	1736	1695	1642	1601	1553	1512	1465	1427	1381
				Heating Rise (°F)	39	40	41	42	44	45	46	48	49
				Heating Rise (°C)	22	22	23	24	24	25	26	26	27
		Med-High	Orange	CFM	2149	2111	2062	2026	1980	1945	1905	1864	1793
				Heating Rise (°F)	NA	NA	NA	NA	NA	35	36	36	38
				Heating Rise (°C)	NA	NA	NA	NA	NA	19	20	20	21
High	Black	CFM	2344	2306	2259	2203	2141	2070	1991	1902	1803		
		Heating Rise (°F)	NA	NA	NA	NA	NA	NA	NA	36	38		
		Heating Rise (°C)	NA	NA	NA	NA	NA	NA	NA	20	21		
48115	30 – 60 (17 – 33)	Low	Blue	CFM	1402	1351	1311	1263	1224	1172	1136	1080	1041
				Heating Rise (°F)	NA	NA	NA	NA	NA	NA	NA	NA	NA
				Heating Rise (°C)	NA	NA	NA	NA	NA	NA	NA	NA	NA
		Med-Low	Pink	CFM	1457	1404	1367	1318	1284	1233	1197	1144	1104
				Heating Rise (°F)	60	NA	NA	NA	NA	NA	NA	NA	NA
				Heating Rise (°C)	33	NA	NA	NA	NA	NA	NA	NA	NA
		Medium ²	Red	CFM	1736	1695	1642	1601	1553	1512	1465	1427	1381
				Heating Rise (°F)	50	51	53	54	56	57	59	NA	NA
				Heating Rise (°C)	28	28	29	30	31	32	33	NA	NA
		Med-High ¹	Orange	CFM	2149	2111	2062	2026	1980	1945	1905	1864	1793
				Heating Rise (°F)	40	41	42	43	44	45	46	47	48
				Heating Rise (°C)	22	23	23	24	24	25	25	26	27
High	Black	CFM	2344	2306	2259	2203	2141	2070	1991	1902	1803		
		Heating Rise (°F)	37	38	38	39	41	42	44	46	48		
		Heating Rise (°C)	21	21	21	22	23	23	24	25	27		
48130	35 – 65 (19 – 36)	Low	Blue	CFM	1402	1351	1311	1263	1224	1172	1136	1080	1041
				Heating Rise (°F)	NA	NA	NA	NA	NA	NA	NA	NA	NA
				Heating Rise (°C)	NA	NA	NA	NA	NA	NA	NA	NA	NA
		Med-Low	Pink	CFM	1457	1404	1367	1318	1284	1233	1197	1144	1104
				Heating Rise (°F)	NA	NA	NA	NA	NA	NA	NA	NA	NA
				Heating Rise (°C)	NA	NA	NA	NA	NA	NA	NA	NA	NA
		Medium ²	Red	CFM	1736	1695	1642	1601	1553	1512	1465	1427	1381
				Heating Rise (°F)	55	57	59	60	62	64	NA	NA	NA
				Heating Rise (°C)	31	32	33	33	34	35	NA	NA	NA
		Med-High ¹	Orange	CFM	2149	2111	2062	2026	1980	1945	1905	1864	1793
				Heating Rise (°F)	45	46	47	48	49	50	51	52	54
				Heating Rise (°C)	25	25	26	26	27	28	28	29	30
High	Black	CFM	2344	2306	2259	2203	2141	2070	1991	1902	1803		
		Heating Rise (°F)	41	42	43	44	45	47	48	51	53		
		Heating Rise (°C)	23	23	24	24	25	26	27	28	30		
60090	35 – 65 (19 – 36)	Low ¹	Blue	CFM	1445	1389	1341	1281	1236	1189	1139	1072	1027
				Heating Rise (°F)	47	49	51	53	55	57	60	63	NA
				Heating Rise (°C)	26	27	28	29	31	32	33	35	NA
		Med-Low	Pink	CFM	1678	1635	1602	1558	1513	1474	1438	1404	1349
				Heating Rise (°F)	41	42	42	44	45	46	47	48	50
				Heating Rise (°C)	23	23	24	24	25	26	26	27	28
		Medium ²	Red	CFM	1962	1915	1880	1843	1794	1753	1711	1675	1628
				Heating Rise (°F)	35	36	36	37	38	39	40	41	42
				Heating Rise (°C)	19	20	20	20	21	22	22	23	23
		Med-High	Orange	CFM	2131	2088	2065	2013	1982	1941	1888	1860	1785
				Heating Rise (°F)	NA	NA	NA	NA	NA	35	36	37	38
				Heating Rise (°C)	NA	NA	NA	NA	NA	19	20	20	21
High	Black	CFM	2461	2409	2339	2286	2192	2140	2062	1968	1874		
		Heating Rise (°F)	NA	NA	NA	NA	NA	NA	NA	35	36		
		Heating Rise (°C)	NA	NA	NA	NA	NA	NA	NA	19	20		

See Legend and Notes following tables.

UNIT AIRFLOW, Horizontal and Downflow Discharge, 230 Volts, Dry Coil

Unit PGD3	Heating Rise Range °F (°C)	Motor Speed	Wire Color		External Static Pressure (in wc)								
					0.1	0.2	0.3	0.4	0.5	0.6	0.7	0.8	0.9
60115	30 – 60 (17 – 33)	Low	Blue	CFM	1445	1389	1341	1281	1236	1189	1139	1072	1027
				Heating Rise (°F)	60	NA	NA	NA	NA	NA	NA	NA	NA
				Heating Rise (°C)	33	NA	NA	NA	NA	NA	NA	NA	NA
		Med-Low	Pink	CFM	1678	1635	1602	1558	1513	1474	1438	1404	1349
				Heating Rise (°F)	52	53	54	56	57	59	60	NA	NA
				Heating Rise (°C)	29	30	30	31	32	33	34	NA	NA
		Medium ²	Red	CFM	1962	1915	1880	1843	1794	1753	1711	1675	1628
				Heating Rise (°F)	44	45	46	47	48	50	51	52	53
				Heating Rise (°C)	25	25	26	26	27	28	28	29	30
		Med-High ¹	Orange	CFM	2131	2088	2065	2013	1982	1941	1888	1860	1785
				Heating Rise (°F)	41	42	42	43	44	45	46	47	49
				Heating Rise (°C)	23	23	23	24	24	25	26	26	27
		High	Black	CFM	2461	2409	2339	2286	2192	2140	2062	1968	1874
				Heating Rise (°F)	35	36	37	38	40	41	42	44	46
				Heating Rise (°C)	20	20	21	21	22	23	23	25	26
60130	35 – 65 (19 – 36)	Low	Blue	CFM	1445	1389	1341	1281	1236	1189	1139	1072	1027
				Heating Rise (°F)	NA	NA	NA	NA	NA	NA	NA	NA	NA
				Heating Rise (°C)	NA	NA	NA	NA	NA	NA	NA	NA	NA
		Med-Low	Pink	CFM	1678	1635	1602	1558	1513	1474	1438	1404	1349
				Heating Rise (°F)	57	59	60	62	64	65	NA	NA	NA
				Heating Rise (°C)	32	33	33	34	35	36	NA	NA	NA
		Medium ²	Red	CFM	1962	1915	1880	1843	1794	1753	1711	1675	1628
				Heating Rise (°F)	49	50	51	52	54	55	56	57	59
				Heating Rise (°C)	27	28	28	29	30	31	31	32	33
		Med-High ¹	Orange	CFM	2131	2088	2065	2013	1982	1941	1888	1860	1785
				Heating Rise (°F)	45	46	47	48	49	50	51	52	54
				Heating Rise (°C)	25	26	26	27	27	28	28	29	30
		High	Black	CFM	2461	2409	2339	2286	2192	2140	2062	1968	1874
				Heating Rise (°F)	39	40	41	42	44	45	47	49	51
				Heating Rise (°C)	22	22	23	23	24	25	26	27	29

*Air delivery values are without air filter and are for dry coil (See Horizontal Wet Coil Pressure Drop table).

¹ Factory-shipped heating speed

² Factory-shipped cooling speed

"NA" = Not allowed for heating speed

Note: For horizontal applications deduct field-supplied air filter pressure drop and wet coil pressure drop to obtain external static pressure available for ducting. For downflow applications see Wet Coil Air Delivery Table for available static including wet coil, 1-in. (25 mm) filter and economizer.

Shaded areas indicate speed/static combinations that are not permitted for dehumidification speed.

HORIZONTAL WET COIL PRESSURE DROP (in wc)															
UNIT PGD3	STANDARD CFM (S.C.F.M)														
	600	700	800	900	1000	1100	1200	1300	1400	1500	1600	1700	1800	1900	2000
24	0.030	0.037	0.044	0.053	0.063	-	-	-	-	-	-	-	-	-	-
30	-	0.037	0.044	0.053	0.063	0.072	0.081	0.105	-	-	-	-	-	-	-
36	-	-	-	0.055	0.060	0.090	0.100	0.110	0.140	-	-	-	-	-	-
42	-	-	-	-	0.045	0.050	0.060	0.065	0.075	0.080	0.090	0.094	0.110	-	-
48	-	-	-	-	-	-	0.041	0.063	0.085	0.100	0.104	0.110	0.120	0.130	-
60	-	-	-	-	-	-	-	-	-	0.060	0.065	0.072	0.077	0.085	0.100

DOWNFLOW WET COIL PRESSURE DROP (in wc) – HIGH SPEED with 1 inch (25mm) Filter and Economizer											
UNIT PGD3	EXTERNAL STATIC PRESSURE (in. W.C.)										
	0.1	0.2	0.3	0.4	0.5	0.6	0.7	0.8	0.9	1.0	
36	1333	1289	1256	1214	1152	1118	1076	1035	997	950	
42	1612	1569	1527	1481	1451	1393	1351	1317	1278	1242	
48	2166	2085	2002	1919	1798	1709	1582	1467	1270	988	
60	2298	2239	2180	2110	2044	1951	1862	1777	1697	1591	

HORIZONTAL FILTER PRESSURE DROP (in wc)																			
FILTER SIZE in. (mm)	CFM																		
	500	600	700	800	900	1000	1100	1200	1300	1400	1500	1600	1700	1800	1900	2000	2100	2200	2300
20X20X1 (508X508X25)	0.05	0.07	0.08	0.1	0.12	0.13	0.14	0.15	-	-	-	-	-	-	-	-	-	-	-
20X24X1 (508X610X25)	-	-	-	-	0.09	0.10	0.11	0.13	0.14	0.15	0.16	-	-	-	-	-	-	-	-
24X30X1 (610X762X25)	-	-	-	0.04	0.05	0.06	0.07	0.07	0.08	0.09	0.1	-	-	-	-	-	-	-	-
24X36X1 (610X914X25)	-	-	-	-	-	-	-	0.06	0.07	0.07	0.08	0.09	0.09	0.10	0.11	0.12	0.13	0.14	0.14

HORIZONTAL ECONOMIZER 1 inch (25mm) FILTER PRESSURE DROP (in wc)	
UNIT PGD3	PRESSURE DROP
24-36	0.20
42-60	0.25

NATURAL GAS ORIFICE SIZES AND MANIFOLD PRESSURE						
Nameplate Input (Btu/hr)		ALTITUDE OF INSTALLATION (FT. ABOVE SEA LEVEL) U.S.A.*				
		0 to 2000 (0-610 m)	2001 to 3000* (611 to 914 m)	3001 to 4000 (915 to 1219 m)	4001 to 5000 (1220 to 1524 m)	5001 to 6000 (1524 to 1829 m)
40000	Orifice No. (Qty)	44 (2)	45 (2)†	48 (2)†	48 (2)†	48 (2)†
	Manifold Press.	3.2	3.2	3.8	3.5	3.2
60000	Orifice No. (Qty)	38 (2)	41 (2)†	41 (2)†	42 (2)†	42 (2)†
	Manifold Press.	3.6	3.8	3.4	3.4	3.2
90000	Orifice No. (Qty)	38 (3)	41 (3)†	41 (3)†	42 (3)†	42 (3)†
	Manifold Press.	3.6	3.8	3.4	3.4	3.2
115000	Orifice No. (Qty)	33 (3)	36 (3)†	36 (3)†	36 (3)†	38 (3)†
	Manifold Press.	3.8	3.8	3.6	3.3	3.6
130000	Orifice No. (Qty)	31 (3)	31 (3)	33 (3)†	33 (3)†	34 (3)†
	Manifold Press.	3.8	3.2	3.7	3.4	3.3

*In the U.S.A., the input rating for altitudes above 2000 ft (610m) must be reduced by 4% for each 1000 ft (305 m) above Sea level.
 In Canada, the input rating for altitudes from 2001 to 4500 ft (611 to 1372 m) above sea level must be derated by 10% by an authorized gas conversion station or dealer.
 For Canadian Installations from 2000 to 4500 ft, use U.S.A. column 2001 to 3000 ft.
 Note: Orifice sizes and manifold pressure settings are based on natural gas with a heating value of 1025 Btu/ft3 and a specific gravity of .6.
 † Orifices available through your distributor.

PROPANE GAS ORIFICE SIZES AND MANIFOLD PRESSURE						
Nameplate Input (Btu/hr)		ALTITUDE OF INSTALLATION (FT. ABOVE SEA LEVEL) U.S.A.*				
		0 to 2000 (0-610 m)	2001 to 3000* (611 to 914 m)	3001 to 4000 (915 to 1219 m)	4001 to 5000 (1220 to 1524 m)	5001 to 6000 (1524 to 1829 m)
40000	Orifice No. (Qty)	55 (2)	56 (2)	56 (2)	56 (2)	56 (2)
	Manifold Press. ("WC)	10.0	11.0	11.0	11.0	10.7
60000	Orifice No. (Qty)	53 (2)	54 (2)	54 (2)	54 (2)	54 (2)
	Manifold Press. ("WC)	10.0	11.0	11.0	11.0	11.0
90000	Orifice No. (Qty)	53 (3)	54 (3)	54 (3)	54 (3)	54 (3)
	Manifold Press. ("WC)	10.0	11.0	11.0	11.0	11.0
115000	Orifice No. (Qty)	51 (3)	52 (3)	52 (3)	53 (3)	53 (3)
	Manifold Press. ("WC)	10.0	11.0	10.6	11.0	11.0
130000	Orifice No. (Qty)	49 (3)	50 (3)	51 (3)	52 (3)	52 (3)
	Manifold Press. ("WC)	10.0	11.0	11.0	11.0	11.0

*In the U.S.A., the input rating for altitudes above 2000 ft (610m) must be reduced by 4% for each 1000 ft (305 m) above Sea level.
 In Canada, the input rating for altitudes from 2001 to 4500 ft (611 to 1372 m) above sea level must be derated by 10% by an authorized gas conversion station or dealer.
 For Canadian Installations from 2000 to 4500 ft, use U.S.A. column 2001 to 3000 ft.
 †Use Kit No. NPLPCONV013A00 (0-2000 ft [0-610 m] above sea level). Use Kit No. NPLPCONV014A00 (2001-6000 ft [611-1829 m] above sea level).

HIGH ALTITUDE COMPENSATION, NATURAL GAS

Nameplate Input (Btu/hr)	Rated Heating Input (Btu/hr), Natural Gas at Installation Altitude Above Sea Level, U.S.A.*				
	0 to 2000 ft (0-610 m)	2001 to 3000 ft* (611 to 914 m)	3001 to 4000 ft (915 to 1219 m)	4001 to 5000 ft (1220 to 1524 m)	5001 to 6000 ft (1524 to 1829 m)
40000	40000	36000	34400	32800	31200
60000	60000	54000	51600	49200	46800
90000	90000	81000	77400	73800	70200
115000	115000	103500	98900	94300	89700
130000	130000	117000	111800	106600	101400

*In the U.S.A., the input rating for altitudes above 2000 ft (610m) must be reduced by 4% for each 1000 ft (305 m) above Sea level.

In Canada, the input rating for altitudes from 2001 to 4500 ft (611 to 1372 m) above sea level must be derated by 10% by an authorized gas conversion station or dealer. For Canadian Installations from 2000 to 4500 ft (610-1372 m), use U.S.A. column 2001 to 3000 ft (611 to 914 m).

HIGH ALTITUDE COMPENSATION, PROPANE GAS

Nameplate Input (Btu/hr)	Rated Heating Input (Btu/hr), LP Gas at Installation Altitude Above Sea Level, U.S.A.*				
	0 to 2000 ft (0-610 m)	2001 to 3000 ft* (611 to 914 m)	3001 to 4000 ft (915 to 1219 m)	4001 to 5000 ft (1220 to 1524 m)	5001 to 6000 ft (1524 to 1829 m)
40000	38000	31700	31700	31700	31200
60000	53000	45900	45900	45800	45800
90000	79000	68900	68900	68600	68600
115000	103000	100400	98900	83000	83000
130000	116000	115500	111800	101300	100400

*In the U.S.A., the input rating for altitudes above 2000 ft (610m) must be reduced by 4% for each 1000 ft (305 m) above Sea level.

In Canada, the input rating for altitudes from 2001 to 4500 ft (611 to 1372 m) above sea level must be derated by 10% by an authorized gas conversion station or dealer. For Canadian Installations from 2000 to 4500 ft (610-1372 m), use U.S.A. column 2001 to 3000 ft (611 to 914 m).

A-WEIGHTED SOUND POWER LEVEL (dBA)

UNIT PGD3	STANDARD RATING dBA	TYPICAL OCTAVE BAND SPECTRUM (dBA without tone adjustment)						
		125	250	500	1000	2000	4000	8000
24	76	66.0	66.0	70.5	71.5	67.5	62.5	58.5
30	75	66.0	63.5	68.0	68.5	67.5	61.5	55.0
36	75	64.0	63.5	68.0	70.5	64.5	61.0	61.0
42	77	67.0	67.0	69.5	70.5	68.0	65.5	61.0
48	78	71.5	66.5	73.0	71.5	68.0	64.0	57.0
60	78	74.5	66.5	70.0	70.0	66.5	64.0	57.0

* Tested in accordance with ARI Standard 270 (not listed in ARI).

PGD324 EXTENDED COOLING PERFORMANCE

EVAPORATOR AIR		CONDENSER ENTERING AIR TEMPERATURES deg F																								
		75 (23.8°C)				85 (29.4°C)				95 (35°C)				105 (40.5°C)				115 (46.1°C)				125 (51.6°C)				
		CFM/BF	EWB	Capacity MBtuh		Total System KW	Capacity MBtuh		Total System KW	Capacity MBtuh		Total System KW	Capacity MBtuh		Total System KW	Capacity MBtuh		Total System KW	Capacity MBtuh		Total System KW	Capacity MBtuh		Total System KW		
Total	Sens			Total	Sens		Total	Sens		Total	Sens		Total	Sens		Total	Sens		Total	Sens		Total	Sens		Total	Sens
700/0.07	57 (13.8)		22.74	1.66	21.26	19.77	18.28	2.06	19.77	18.28	2.29	16.77	16.77	2.54	15.24	15.24	2.80	16.77	16.77	2.29	16.77	16.77	2.54	15.24	15.24	2.80
	62 (16.6)		23.94	1.66	22.18	19.57	18.66	2.07	20.42	18.59	2.30	16.93	16.57	2.54	15.24	15.24	2.81	16.93	16.57	2.30	16.93	16.57	2.54	15.24	15.24	2.81
	63* (17.2)		24.48	1.67	22.88	16.12	18.66	2.07	20.88	15.23	2.30	17.27	13.46	2.55	16.70	13.07	2.82	17.27	13.46	2.30	17.27	13.46	2.55	16.70	13.07	2.82
800/0.09	67 (19.4)		26.34	1.67	24.42	16.65	18.66	2.08	22.49	15.76	2.31	20.56	11.25	2.56	18.45	10.43	2.83	20.56	11.25	2.31	20.56	11.25	2.56	18.45	10.43	2.83
	72 (22.2)		28.95	1.67	26.85	13.70	18.71	2.08	24.76	12.88	2.31	22.66	12.07	2.56	18.45	10.43	2.83	22.66	12.07	2.31	22.66	12.07	2.56	18.45	10.43	2.83
	63* (17.2)		23.78	1.68	22.21	22.21	18.81	2.08	20.64	20.64	2.31	17.46	17.46	2.56	15.85	15.85	2.82	17.46	17.46	2.31	17.46	17.46	2.56	15.85	15.85	2.82
900/0.1	62 (16.6)		24.57	1.68	22.75	20.99	18.71	2.08	20.94	19.93	2.31	19.15	18.83	2.31	17.46	17.46	2.82	19.15	18.83	2.31	17.46	17.46	2.56	15.85	15.85	2.82
	63* (17.2)		25.10	1.68	23.23	17.14	18.81	2.09	21.36	16.21	2.32	19.49	15.29	2.32	17.62	13.44	2.82	19.49	15.29	2.32	17.62	13.44	2.56	15.74	13.44	2.82
	67 (19.4)		27.00	1.69	25.00	17.73	18.81	2.10	23.00	16.80	2.33	21.01	15.87	2.33	19.01	14.94	2.83	21.01	15.87	2.33	19.01	14.94	2.57	17.00	14.00	2.83
1000/0.03	72 (22.2)		29.65	1.69	27.48	14.39	18.91	2.10	25.30	13.54	2.33	23.13	12.71	2.58	18.77	11.01	2.84	23.13	12.71	2.33	23.13	12.71	2.58	18.77	11.01	2.84
	57 (13.8)		24.67	1.70	23.02	23.02	18.91	2.10	21.37	21.37	2.33	18.05	18.05	2.58	16.36	16.36	2.84	18.05	18.05	2.33	18.05	18.05	2.58	16.36	16.36	2.84
	62 (16.6)		25.09	1.70	23.23	22.27	18.91	2.10	21.39	21.39	2.33	18.04	18.04	2.58	16.36	16.36	2.84	18.04	18.04	2.33	18.04	18.04	2.58	16.36	16.36	2.84
1125/0.04	63* (17.2)		25.60	1.70	23.66	18.11	18.91	2.10	21.74	17.15	2.33	17.89	15.24	2.58	15.96	14.27	2.84	17.89	15.24	2.33	17.89	15.24	2.58	15.96	14.27	2.84
	67 (19.4)		27.52	1.70	25.45	18.76	19.01	2.11	23.40	16.83	2.34	21.34	16.83	2.59	17.23	14.89	2.85	21.34	16.83	2.34	19.29	15.87	2.59	17.23	14.89	2.85
	72 (22.2)		30.21	1.71	27.97	15.04	19.01	2.11	25.72	14.18	2.35	23.50	13.31	2.60	19.02	11.58	2.86	23.50	13.31	2.35	21.26	12.45	2.60	19.02	11.58	2.86

PGD330 EXTENDED COOLING PERFORMANCE

EVAPORATOR AIR		CONDENSER ENTERING AIR TEMPERATURES deg F																								
		75 (23.8°C)				85 (29.4°C)				95 (35°C)				105 (40.5°C)				115 (46.1°C)				125 (51.6°C)				
		CFM/BF	EWB	Capacity MBtuh		Total System KW	Capacity MBtuh		Total System KW	Capacity MBtuh		Total System KW	Capacity MBtuh		Total System KW	Capacity MBtuh		Total System KW	Capacity MBtuh		Total System KW	Capacity MBtuh		Total System KW		
Total	Sens			Total	Sens		Total	Sens		Total	Sens		Total	Sens		Total	Sens		Total	Sens		Total	Sens		Total	Sens
875/0.03	57 (13.8)		29.20	2.09	27.20	27.20	23.18	2.52	25.19	25.19	2.77	23.18	23.18	3.04	19.13	19.13	3.32	23.18	23.18	2.77	23.18	23.18	3.04	19.13	19.13	3.32
	62 (16.6)		30.09	2.09	27.78	25.28	23.30	2.52	24.10	24.10	2.77	23.22	23.12	3.04	19.12	19.12	3.32	23.22	23.12	2.77	23.22	23.12	3.04	19.12	19.12	3.32
	63* (17.2)		30.75	2.09	28.36	20.61	23.30	2.52	25.99	19.56	2.77	23.63	18.51	3.04	19.12	19.12	3.32	23.63	18.51	2.77	23.63	18.51	3.04	19.12	19.12	3.32
1000/0.03	67 (19.4)		33.12	2.08	30.58	21.34	22.91	2.08	28.05	20.29	2.77	25.52	19.23	3.04	20.48	17.08	3.32	25.52	19.23	2.77	25.52	19.23	3.04	20.48	17.08	3.32
	72 (22.2)		36.50	2.08	33.73	17.33	22.91	2.08	30.97	16.37	2.52	28.22	15.41	3.04	22.73	13.46	3.32	28.22	15.41	2.52	28.22	15.41	3.04	22.73	13.46	3.32
	57 (13.8)		30.51	2.12	28.39	28.39	23.33	2.12	26.27	26.27	2.80	24.14	24.14	3.07	19.87	19.87	3.35	24.14	24.14	2.80	24.14	24.14	3.07	19.87	19.87	3.35
1125/0.04	62 (16.6)		30.85	2.12	28.49	28.24	23.33	2.12	26.26	26.26	2.56	24.14	24.14	3.07	19.86	19.86	3.35	24.14	24.14	2.56	24.14	24.14	3.07	19.86	19.86	3.35
	63* (17.2)		31.44	2.12	28.97	22.02	23.33	2.12	26.51	20.93	2.81	24.07	19.84	3.07	20.80	18.40	3.35	24.07	19.84	2.81	24.07	19.84	3.07	20.80	18.40	3.35
	67 (19.4)		33.86	2.12	31.22	22.85	23.33	2.12	28.60	21.75	2.55	25.99	20.65	3.07	20.80	18.40	3.35	25.99	20.65	2.55	25.99	20.65	3.07	20.80	18.40	3.35
1125/0.04	72 (22.2)		37.30	2.15	34.43	18.29	23.32	2.15	31.58	17.30	2.84	28.74	16.31	3.10	20.48	17.29	3.39	31.58	17.30	2.84	28.74	16.31	3.10	20.48	17.29	3.39
	57 (13.8)		31.61	2.15	29.39	29.39	23.36	2.15	27.17	27.17	2.59	24.95	24.95	3.10	20.48	17.29	3.39	24.95	24.95	2.59	24.95	24.95	3.10	20.48	17.29	3.39
	62 (16.6)		31.61	2.15	29.39	29.39	23.36	2.15	27.17	27.17	2.59	24.95	24.95	3.10	20.48	17.29	3.39	24.95	24.95	2.59	24.95	24.95	3.10	20.48	17.29	3.39
1125/0.04	63* (17.2)		31.97	2.15	29.43	23.38	23.36	2.15	26.91	22.25	2.84	24.41	21.10	3.10	20.48	17.29	3.39	26.91	22.25	2.84	24.41	21.10	3.10	20.48	17.29	3.39
	67 (19.4)		34.42	2.15	31.71	24.30	23.36	2.15	29.02	23.16	2.84	26.35	22.01	3.10	20.48	17.29	3.39	26.35	22.01	2.84	26.35	22.01	3.10	20.48	17.29	3.39
	72 (22.2)		37.91	2.14	34.96	19.20	23.35	2.14	32.03	18.19	2.58	29.12	17.17	3.10	20.48	17.29	3.39	32.03	18.19	2.58	29.12	17.17	3.10	20.48	17.29	3.39

See Legend and Notes following tables.

PGD336 EXTENDED COOLING PERFORMANCE

CONDENSER ENTERING AIR TEMPERATURES deg F

CFM/BF	EWB	75 (23.8°C)						85 (29.4°C)						95 (35°C)						105 (40.5°C)						115 (46.1°C)						125 (51.6°C)					
		Capacity MBtuh			Total System KW			Capacity MBtuh			Total System KW			Capacity MBtuh			Total System KW			Capacity MBtuh			Total System KW			Capacity MBtuh			Total System KW			Capacity MBtuh			Total System KW		
		Total	Sens		Total	Sens		Total	Sens		Total	Sens		Total	Sens		Total	Sens		Total	Sens		Total	Sens		Total	Sens		Total	Sens							
1050/0.04	57 (13.8)	35.66	35.66	2.38	32.84	32.84	2.71	30.06	30.06	3.07	27.32	27.32	3.47	24.62	24.62	3.91	21.93	21.93	4.39	18.77	18.77	4.99	15.44	15.44	5.69	12.26	12.26	6.49	9.07	9.07	7.29	5.66	5.66				
	62 (16.6)	37.06	32.25	2.39	33.82	30.46	2.71	30.65	28.68	3.07	27.56	26.88	3.47	24.62	24.62	3.91	21.93	21.93	4.39	18.77	18.77	4.99	15.44	15.44	5.69	12.26	12.26	6.49	9.07	9.07	7.29	5.66	5.66				
	63* (17.2)	37.87	26.52	2.39	34.55	24.93	2.71	31.28	23.37	3.08	28.09	21.82	3.48	24.95	20.29	3.91	21.88	18.77	4.39	15.44	15.44	4.99	12.26	12.26	5.69	9.07	9.07	7.29	5.66	5.66	7.29	5.66	5.66				
1200/0.04	67 (19.4)	40.79	27.41	2.39	37.23	25.80	2.72	33.74	24.21	3.08	30.32	22.64	3.48	26.96	21.09	3.92	19.54	19.54	4.39	15.44	15.44	4.99	12.26	12.26	5.69	9.07	9.07	7.29	5.66	5.66	7.29	5.66	5.66				
	72 (22.2)	44.91	22.49	2.39	41.02	21.04	2.72	37.19	19.82	3.09	33.45	18.21	3.49	29.78	16.82	3.93	15.44	15.44	4.39	12.26	12.26	4.99	9.07	9.07	5.69	5.66	5.66	7.29	5.66	5.66	7.29	5.66	5.66				
	57 (13.8)	37.24	37.24	2.43	34.27	34.27	2.76	31.33	31.33	3.12	28.44	28.44	3.52	25.58	25.58	3.96	22.76	22.76	4.44	18.77	18.77	4.99	15.44	15.44	5.69	12.26	12.26	6.49	9.07	9.07	7.29	5.66	5.66				
1350/0.05	62 (16.6)	37.97	34.65	2.43	34.64	32.72	2.76	31.35	31.35	3.12	28.43	28.43	3.52	25.58	25.58	3.96	22.75	22.75	4.44	18.77	18.77	4.99	15.44	15.44	5.69	12.26	12.26	6.49	9.07	9.07	7.29	5.66	5.66				
	63* (17.2)	38.73	28.25	2.43	35.29	26.59	2.76	31.91	24.95	3.12	28.60	23.33	3.52	25.37	21.73	3.96	22.21	20.12	4.44	18.77	18.77	4.99	15.44	15.44	5.69	12.26	12.26	6.49	9.07	9.07	7.29	5.66	5.66				
	67 (19.4)	41.71	29.24	2.44	38.02	27.56	2.76	34.40	25.90	3.13	30.86	24.26	3.53	27.40	22.63	3.97	24.00	21.00	4.44	18.77	18.77	4.99	15.44	15.44	5.69	12.26	12.26	6.49	9.07	9.07	7.29	5.66	5.66				
1400/0.04	72 (22.2)	45.90	23.65	2.44	41.86	22.16	2.77	37.91	20.68	3.13	34.05	19.23	3.54	30.26	17.79	3.98	16.36	16.36	4.44	18.77	18.77	4.99	15.44	15.44	5.69	12.26	12.26	6.49	9.07	9.07	7.29	5.66	5.66				
	57 (13.8)	38.59	38.59	2.48	35.47	35.47	2.81	32.40	32.40	3.17	29.37	29.37	3.57	26.39	26.39	4.01	23.43	23.43	4.49	18.77	18.77	4.99	15.44	15.44	5.69	12.26	12.26	6.49	9.07	9.07	7.29	5.66	5.66				
	62 (16.6)	38.77	36.79	2.48	35.46	35.46	2.81	32.39	32.39	3.17	29.37	29.37	3.57	26.38	26.38	4.01	23.43	23.43	4.49	18.77	18.77	4.99	15.44	15.44	5.69	12.26	12.26	6.49	9.07	9.07	7.29	5.66	5.66				
1575/0.05	63* (17.2)	39.40	29.91	2.48	35.85	28.18	2.81	32.38	26.47	3.17	28.99	24.78	3.57	25.69	23.09	4.01	22.46	21.40	4.49	18.77	18.77	4.99	15.44	15.44	5.69	12.26	12.26	6.49	9.07	9.07	7.29	5.66	5.66				
	67 (19.4)	42.41	31.01	2.48	38.61	29.26	2.81	34.89	27.92	3.18	31.27	25.81	3.58	27.72	24.10	4.02	24.26	22.39	4.49	18.77	18.77	4.99	15.44	15.44	5.69	12.26	12.26	6.49	9.07	9.07	7.29	5.66	5.66				
	72 (22.2)	46.65	24.77	2.49	42.51	23.22	2.82	38.45	21.70	3.18	34.49	20.20	3.58	30.61	18.72	4.03	26.80	17.24	4.50	18.77	18.77	4.99	15.44	15.44	5.69	12.26	12.26	6.49	9.07	9.07	7.29	5.66	5.66				

PGD342 EXTENDED COOLING PERFORMANCE

CONDENSER ENTERING AIR TEMPERATURES deg F

CFM/BF	EWB	75 (23.8°C)						85 (29.4°C)						95 (35°C)						105 (40.5°C)						115 (46.1°C)						125 (51.6°C)					
		Capacity MBtuh			Total System KW			Capacity MBtuh			Total System KW			Capacity MBtuh			Total System KW			Capacity MBtuh			Total System KW			Capacity MBtuh			Total System KW			Capacity MBtuh			Total System KW		
		Total	Sens		Total	Sens		Total	Sens		Total	Sens		Total	Sens		Total	Sens		Total	Sens		Total	Sens		Total	Sens		Total	Sens							
1225/0.03	57 (13.8)	40.45	40.45	3.00	37.98	37.98	3.37	35.49	35.49	3.78	32.98	32.98	4.20	30.44	30.44	4.65	27.84	27.84	5.10	18.77	18.77	5.10	15.44	15.44	5.69	12.26	12.26	6.49	9.07	9.07	7.29	5.66	5.66				
	62 (16.6)	42.06	37.63	2.94	39.15	35.73	3.33	36.25	33.83	3.74	33.37	31.92	4.18	30.48	30.39	4.64	27.88	27.88	5.10	18.77	18.77	4.99	15.44	15.44	5.69	12.26	12.26	6.49	9.07	9.07	7.29	5.66	5.66				
	63* (17.2)	42.93	30.96	2.91	39.95	29.27	3.31	36.96	27.59	3.72	33.97	25.92	4.17	30.95	24.26	4.63	27.90	22.59	5.10	18.77	18.77	4.99	15.44	15.44	5.69	12.26	12.26	6.49	9.07	9.07	7.29	5.66	5.66				
1400/0.04	67 (19.4)	46.12	31.94	2.80	42.92	30.23	3.19	39.72	28.52	3.61	36.53	26.83	4.05	33.31	25.15	4.52	30.04	23.46	4.99	18.77	18.77	4.99	15.44	15.44	5.69	12.26	12.26	6.49	9.07	9.07	7.29	5.66	5.66				
	72 (22.2)	50.58	26.16	2.65	47.09	24.61	3.04	43.59	23.08	3.46	40.11	21.56	3.90	36.60	20.05	4.37	33.04	18.53	4.84	18.77	18.77	4.99	15.44	15.44	5.69	12.26	12.26	6.49	9.07	9.07	7.29	5.66	5.66				
	57 (13.8)	42.24	42.24	2.98	39.61	39.61	3.35	36.97	36.97	3.76	34.32	34.32	4.18	31.63	31.63	4.63	28.88	28.88	5.08	18.77	18.77	4.99	15.44	15.44	5.69	12.26	12.26	6.49	9.07	9.07	7.29	5.66	5.66				
1575/0.05	62 (16.6)	43.11	40.44	2.95	40.11	38.38	3.34	37.15	36.28	3.75	34.31	34.31	4.18	31.62	31.62	4.63	28.88	28.88	5.08	18.77	18.77	4.99	15.44	15.44	5.69	12.26	12.26	6.49	9.07	9.07	7.29	5.66	5.66				
	63* (17.2)	43.91	32.97	2.92	40.81	31.21	3.32	37.71	29.45	3.73	34.61	27.70	4.18	31.49	25.96	4.64	28.35	24.21	5.12	18.77	18.77	4.99	15.44	15.44	5.69	12.26	12.26	6.49	9.07	9.07	7.29	5.66	5.66				
	67 (19.4)	47.15	34.07	2.81	43.82	32.28	3.20	40.50	30.50	3.62	37.19	28.73	4.06	33.86	26.97	4.53	30.50	25.20	5.00	18.77	18.77	4.99	15.44	15.44	5.69	12.26	12.26	6.49	9.07	9.07	7.29	5.66	5.66				
1575/0.05	72 (22.2)	51.67	27.51	2.65	48.05	25.91	3.05	44.42	24.32	3.46	40.81	22.75	3.91	37.19	21.19	4.38	33.51	19.62	4.85	18.77	18.77	4.99	15.44	15.44	5.69	12.26	12.26	6.49	9.07	9.07	7.29	5.66	5.66				
	57 (13.8)	43.75	43.75	2.97	40.99	40.99	3.34	38.22	38.22	3.75	35.43	35.43	4.17	32.62	32.62	4.62	29.74	29.74	5.07	18.77	18.77	4.99	15.44	15.44	5.69	12.26	12.26	6.49	9.07	9.07	7.29	5.66	5.66				
	62 (16.6)	44.02	42.95	2.96	41.01	41.01	3.34	38.21	38.21	3.75	35.43	35.43	4.17	32.61	32.61	4.62	29.74	29.74	5.07	18.77	18.77	4.99	15.44	15.44	5.69	12.26	12.26	6.49	9.07	9.07	7.29	5.66	5.66				
1575/0.05	63* (17.2)	44.67	34.90	2.94	41.47	33.06	3.33	38.28	31.23	3.75	35.10	29.41	4.20	31.91	27.58	4.66	28.70	25.74	5.14	18.77	18.77	4.99	15.44	15.44	5.69	12.26	12.26	6.49	9.07	9.07	7.29	5.66	5.66				
	67 (19.4)	47.93	36.13	2.82	44.51	34.26	3.21	41.09	32.40	3.63	37.69	30.56	4.08	34.28	28.71	4.54	30.85	26.85	5.02	18.77	18.77	4.99	15.44	15.44	5.69	12.26	12.26	6.49	9.07	9.07	7.29	5.66	5.66				
	72 (22.2)	52.51	28.80	2.67	48.78	27.15	3.06	45.05	25.51	3.48	41.34	23.89	3.93	37.63	22.28	4.39	33.86	20.67	4.87	18.77	18.77	4.99	15.44	15.44	5.69	12.26	12.26	6.49	9.07	9.07	7.29	5.66	5.66				

See Legend and Notes following tables.

PGD348 EXTENDED COOLING PERFORMANCE

EVAPORATOR AIR		CONDENSER ENTERING AIR TEMPERATURES deg F																							
		75 (23.8°C)				85 (29.4°C)				95 (35°C)				105 (40.5°C)				115 (46.1°C)				125 (51.6°C)			
		CFM/BF	EWB	Capacity MBtuh		Total System KW	Capacity MBtuh		Total System KW	Capacity MBtuh		Total System KW	Capacity MBtuh		Total System KW	Capacity MBtuh		Total System KW	Capacity MBtuh		Total System KW				
Total	Sens			Total	Sens		Total	Sens		Total	Sens		Total	Sens		Total	Sens		Total	Sens					
1400/0.04	57 (13.8)	46.51	46.51	3.29	43.60	43.60	3.68	40.66	40.66	4.11	37.70	37.70	4.56	34.70	34.70	5.05	31.64	31.64	5.55						
	62 (16.6)	48.43	41.91	3.29	45.02	40.09	3.68	41.60	38.24	4.10	38.19	36.35	4.56	34.81	34.56	5.05	31.64	31.64	5.55						
	63* (17.2)	49.45	34.51	3.29	45.95	32.87	3.68	42.43	31.22	4.10	38.89	29.56	4.56	35.34	27.89	5.05	31.75	26.19	5.55						
1600/0.05	67 (19.4)	53.14	35.61	3.29	49.39	33.95	3.68	45.62	32.29	4.10	41.85	30.61	4.55	38.05	28.93	5.04	34.20	27.21	5.55						
	72 (22.2)	58.33	29.19	3.28	54.23	27.68	3.67	50.11	26.15	4.09	46.00	24.62	4.55	41.85	23.08	5.03	37.64	21.51	5.54						
	57 (13.8)	48.55	48.55	3.35	45.46	45.46	3.74	42.35	42.35	4.16	39.21	39.21	4.61	36.04	36.04	5.10	32.81	32.81	5.60						
1800/0.06	62 (16.6)	49.62	44.99	3.35	46.10	43.02	3.74	42.60	40.97	4.16	39.21	39.21	4.61	36.04	36.04	5.10	32.80	32.80	5.60						
	63* (17.2)	50.57	36.73	3.35	46.92	33.30	3.74	43.27	33.30	4.16	39.61	31.57	4.61	35.94	29.83	5.10	32.24	28.05	5.60						
	67 (19.4)	54.31	37.96	3.34	50.41	36.23	3.73	46.50	34.50	4.15	42.59	32.76	4.61	38.66	30.99	5.09	34.70	29.20	5.60						
2000/0.02	72 (22.2)	59.58	30.68	3.34	55.32	29.12	3.73	51.05	27.54	4.15	46.80	25.97	4.60	42.51	24.38	5.08	38.17	22.76	5.59						
	57 (13.8)	50.26	50.26	3.40	47.02	47.02	3.79	43.76	43.76	4.21	40.47	40.47	4.66	37.15	37.15	5.15	33.76	33.76	5.65						
	62 (16.6)	50.64	47.75	3.40	47.06	47.06	3.79	43.75	43.75	4.21	40.46	40.46	4.66	37.14	37.14	5.15	33.76	33.76	5.65						
2250/0.03	63* (17.2)	51.44	38.88	3.40	47.67	37.10	3.79	43.92	35.31	4.21	40.16	33.51	4.67	36.40	31.68	5.15	32.62	29.81	5.66						
	67 (19.4)	55.22	40.25	3.40	51.19	38.45	3.79	47.17	36.64	4.21	43.16	34.83	4.66	39.13	32.98	5.14	35.08	31.10	5.65						
	72 (22.2)	60.54	32.12	3.40	56.16	30.51	3.78	51.77	28.89	4.20	47.40	27.27	4.65	43.00	25.64	5.13	38.55	23.98	5.64						

PGD360 EXTENDED COOLING PERFORMANCE

EVAPORATOR AIR		CONDENSER ENTERING AIR TEMPERATURES deg F																							
		75 (23.8°C)				85 (29.4°C)				95 (35°C)				105 (40.5°C)				115 (46.1°C)				125 (51.6°C)			
		CFM/BF	EWB	Capacity MBtuh		Total System KW	Capacity MBtuh		Total System KW	Capacity MBtuh		Total System KW	Capacity MBtuh		Total System KW	Capacity MBtuh		Total System KW	Capacity MBtuh		Total System KW				
Total	Sens			Total	Sens		Total	Sens		Total	Sens		Total	Sens		Total	Sens		Total	Sens					
1750/0.02	57 (13.8)	57.89	57.89	4.22	54.53	54.53	4.64	51.13	51.13	5.08	47.68	47.68	5.56	44.15	44.15	6.06	40.50	40.50	6.59						
	62 (16.6)	59.66	51.98	4.24	55.71	49.84	4.65	51.77	47.88	5.09	47.84	45.44	5.56	44.15	44.15	6.06	40.49	40.49	6.59						
	63* (17.2)	60.79	42.58	4.25	56.72	40.64	4.66	52.64	38.69	5.10	48.53	36.74	5.57	44.37	34.78	6.06	40.12	32.78	6.58						
2000/0.02	67 (19.4)	65.28	43.94	4.28	60.89	41.97	4.70	56.50	40.00	5.14	52.08	38.03	5.61	47.59	36.03	6.10	43.00	34.00	6.62						
	72 (22.2)	71.52	35.78	4.34	66.71	33.95	4.75	61.88	32.13	5.19	57.02	30.30	5.66	52.07	28.45	6.15	47.01	26.57	6.66						
	57 (13.8)	60.39	60.39	4.33	56.80	56.80	4.74	53.18	53.18	5.18	49.50	49.50	5.66	45.74	45.74	6.16	41.85	41.85	6.68						
2250/0.03	62 (16.6)	61.11	55.94	4.33	57.07	53.59	4.74	53.18	53.18	5.18	49.50	49.50	5.66	45.74	45.74	6.16	41.85	41.85	6.68						
	63* (17.2)	62.07	45.41	4.34	57.83	43.39	4.75	53.59	41.36	5.19	49.33	39.33	5.66	45.03	37.28	6.15	40.64	35.18	6.67						
	67 (19.4)	66.60	46.95	4.38	62.04	44.89	4.79	57.48	42.84	5.23	52.89	40.78	5.69	48.25	38.70	6.19	43.52	36.58	6.70						
2500/0.03	72 (22.2)	72.91	37.66	4.43	67.90	33.78	4.85	62.90	33.90	5.28	57.85	32.01	5.75	52.74	30.11	6.24	47.52	28.18	6.74						
	57 (13.8)	62.47	62.47	4.43	58.69	58.69	4.84	54.87	54.87	5.28	51.00	51.00	5.75	47.03	47.03	6.25	42.94	42.94	6.77						
	62 (16.6)	62.48	62.48	4.43	58.68	58.68	4.84	54.86	54.86	5.28	50.99	50.99	5.75	47.03	47.03	6.25	42.94	42.94	6.77						
2750/0.03	63* (17.2)	63.04	48.14	4.43	58.67	46.04	4.84	54.31	43.93	5.28	49.93	41.81	5.74	45.52	39.67	6.23	41.04	37.45	6.75						
	67 (19.4)	67.60	49.85	4.47	62.90	47.72	4.88	58.21	45.59	5.32	53.50	43.44	5.78	48.74	41.27	6.27	43.91	39.04	6.78						
	72 (22.2)	73.95	39.47	4.53	68.79	37.54	4.94	63.63	35.61	5.37	58.45	33.68	5.84	53.20	31.73	6.32	47.86	29.75	6.82						

* 63°F Ewb is at 75°F entering dry bulb — Tennessee Valley Authority (TVA) rating conditions; all others at 80°F entering dry bulb.

LEGEND: BF — Bypass Factor Ewb — Entering Wet Bulb kW — Total Unit Power Input SHC — Sensible Heat Capacity (x1000 Btuh) TC — Total Capacity (x1000 Btuh) (net)

- NOTES:
 1. Ratings are net; they account for the effects of the evaporator fan motor power and heat.
 2. Direct interpolation is permissible. Do not extrapolate.
 3. The following formulas may be used:

$$t_{Ldb} = t_{Edb} - \frac{\text{Sensible Capacity (BTU/h)}}{1.10 \times \text{cfm}}$$

$$h_{Lwb} = h_{Ewb} - \frac{\text{Total Capacity (BTU/h)}}{4.5 \times \text{cfm}}$$

Where: h_{Ewb} = Enthalpy of air entering evaporator coil

Unit PGD3	ELECTRICAL CHARACTERISTICS	UNIT WT.			UNIT HEIGHT IN/MM			CENTER OF GRAVITY IN/MM			
		LB.	KG	"A"	"A"	X	Y	Z			
2400/060	208/230-1-60	304	137.8	40.0	1016.0	22-13/16	579.4	15-5/16	388.9	15-11/16	398.5
3000/060	208/230-1-60	309	140.0	42.0	1066.8	22-13/16	579.4	15-5/16	388.9	15-13/16	401.6
3600/090	208/230-1-60	319	144.6	46.0	1168.4	22-13/16	579.4	15-5/16	388.9	16-5/8	422.3

Unit PGD3	VOLTAGE	CORNER WEIGHT LB/KG			REQUIRED CLEARANCES TO COMBUSTIBLE MATL.			INCHES (MM)			
		"1"	"2"	"3"	"4"	TOP OF UNIT	SIDE OF UNIT	DUCT SIDE OF UNIT	DUCT OPPOSITE DUCTS	DUCT OPPOSITE DUCTS	FLUE PANEL
2400/060	208/230	45.6	20.7	60.8	27.6	1.1	1.4	1.06	3	48.3	1.4
3000/060	208/230	46.3	21.1	61.8	28.0	1.1	1.4	1.08	3	49.1	1.4
3600/090	208/230	47.8	21.7	63.8	28.9	1.1	1.4	1.11	3	50.6	1.4

NEC. REQUIRED CLEARANCES:
 BETWEEN UNITS, POWER ENTRY SIDE
 UNIT AND UNGRADED SURFACES, POWER ENTRY SIDE.....36 [914.0]
 UNIT AND BLOCK OR CONCRETE WALLS AND OTHER
 GRADED SURFACES, POWER ENTRY SIDE.....42 [1066.8]
 REQUIRED CLEARANCE FOR OPERATION AND SERVICING
 EVAP. COIL ACCESS SIDE.....42 [1066.8]
 POWER ENTRY SIDE.....42 [1066.8]
 (EXCEPT FOR NEC REQUIREMENTS)
 UNIT TOP OPPOSITE DUCTS.....48 [1219.2]
 UNIT SIDE OPPOSITE DUCTS.....48 [1219.2]
 DUCT PANEL.....12 [304.8]
 *MINIMUM DISTANCES: IF UNIT IS PLACED LESS THAN 12 [304.8] FROM WALL
 SYSTEM, THEN SYSTEM PERFORMANCE MAY BE COMPROMISED.

DIMENSIONS IN [] ARE IN MM

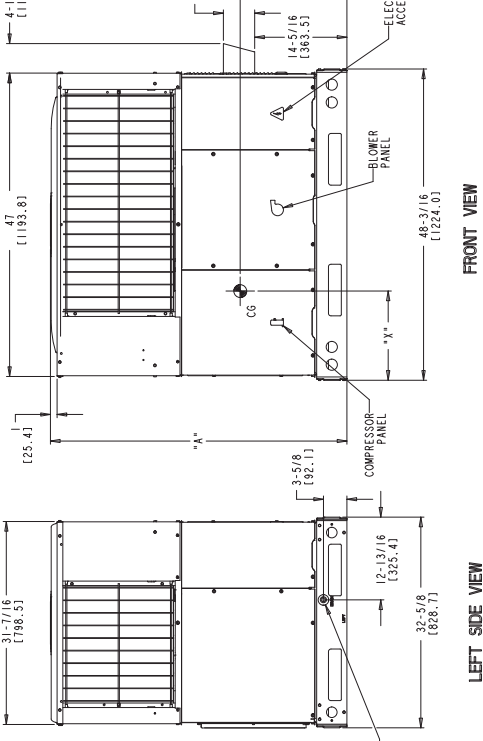
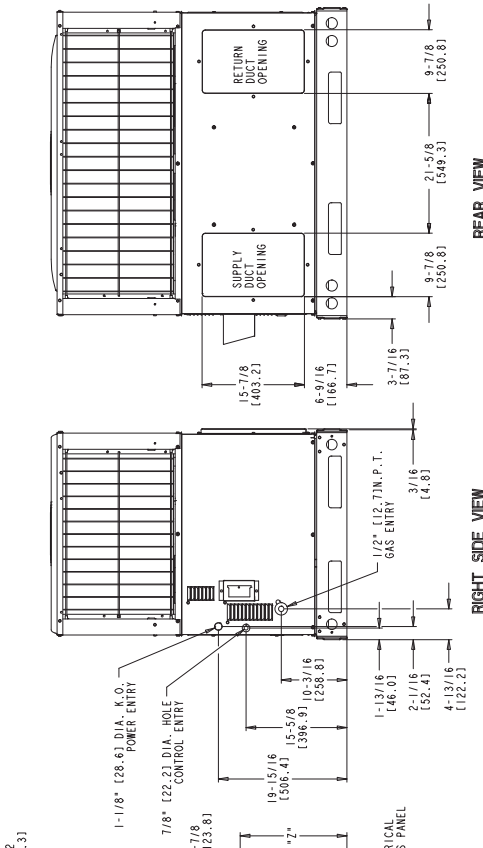
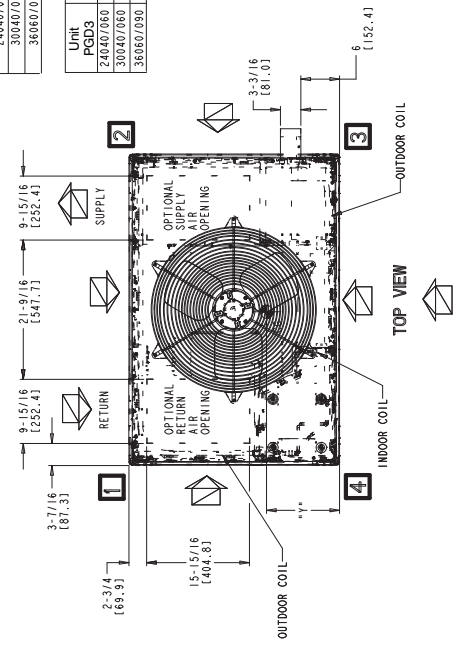

UNIT DIMENSIONS, PGD342 - 60

Unit	ELECTRICAL CHARACTERISTICS	UNIT WT.	UNIT HEIGHT IN/MM			CENTER OF GRAVITY IN/MM					
			LB	KG	"A"	X	Y	Z			
PGD3	208/230-1 60	411	186.5	39-15/16	101.4	22-13/16	579.4	18	457.2	17-1/8	435.0
42000/090	208/230-1 60	419	190.2	41-15/16	106.5	22-13/16	579.4	18	457.2	17-3/8	441.3
48000/115/130	208/230-1 60	441	200.1	41-15/16	106.5	22-13/16	579.4	18	457.2	17-5/8	447.7

REQUIRED CLEARANCES TO COMBUSTIBLE MATL.

	INCHES [MM]
TOP OF UNIT.....	14 [355.6]
DUCT SIDE OF UNIT.....	2 [50.8]
SIDE OPPOSITE DUCTS.....	4 [101.6]
DUCT OPPOSITE UNIT.....	4 [101.6]
FUELS PANEL.....	36 [914.4]

NEC - REQUIRED CLEARANCES.

	INCHES [MM]
BETWEEN UNITS, POWER ENTRY SIDE.....	36 [914.4]
UNIT AND UNGROUND SURFACES, POWER ENTRY SIDE.....	36 [914.4]
UNIT AND BLOCK OR CONCRETE WALLS AND OTHER GROUND SURFACES, POWER ENTRY SIDE.....	42 [1066.8]

REQUIRED CLEARANCE FOR OPERATION AND SERVICING

	INCHES [MM]
EVAP. COIL ACCESS SIDE.....	36 [914.4]
POWER ENTRY SIDE.....	42 [1066.8]
UNIT TOP FOR NEC REQUIREMENTS.....	48 [1219.2]
SIDE OPPOSITE DUCTS.....	36 [914.4]
DUCT PANEL.....	12 [304.8]

*MINIMUM DISTANCES IF UNIT IS PLACED LESS THAN 12 [304.8] FROM WALL SYSTEM, THEN SYSTEM PERFORMANCE MAY BE COMPROMISED.

DIMENSIONS IN () ARE IN MM

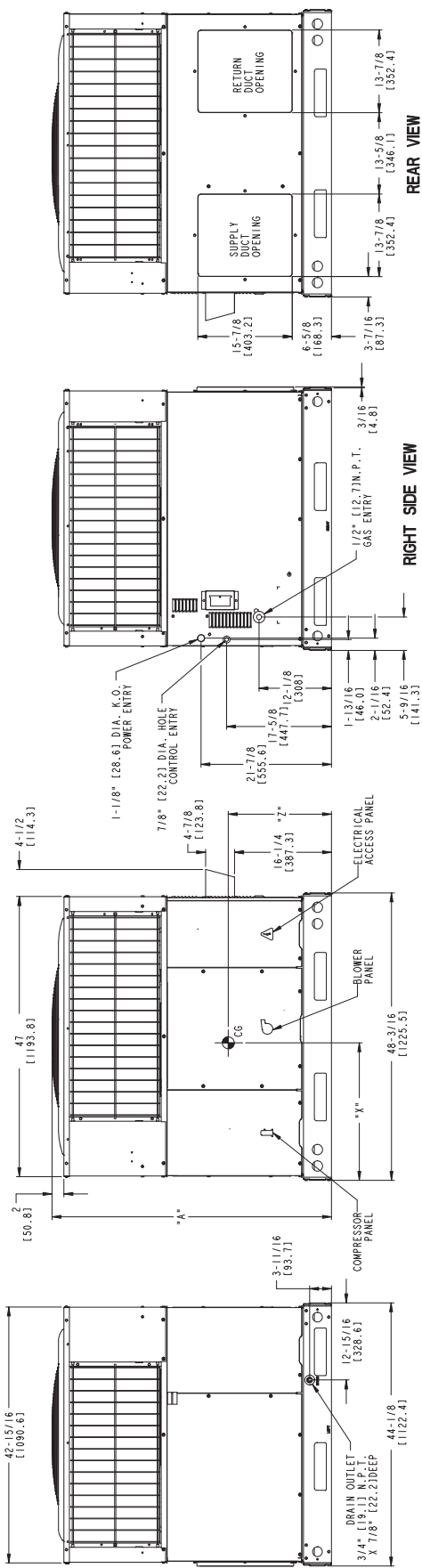
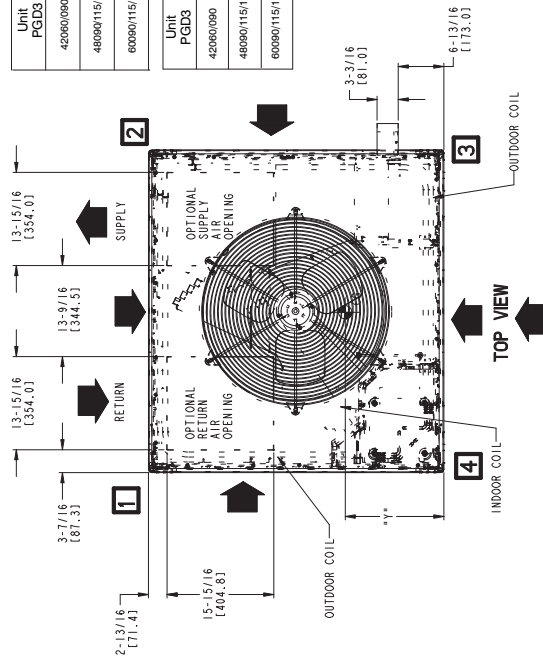

DANGER: ELECTRICAL SHOCK HAZARD DISCONNECT POWER BEFORE SERVICING

SCHMATIC
208/230-1-60

- NOTES:
- IF ANY OF THE ORIGINAL WIRES FURNISHED ARE REPLACED, THEY MUST BE REPLACED WITH TYPE 90 DEG. C WIRE OR ITS EQUIVALENT.
 - USE 75 DEG. COPPER CONDUCTORS FOR FIELD INSTALLATION.
 - SEE INSTALLATION INSTRUCTIONS FOR PROPER HEATING AND COOLING CONNECTIONS FOR YOUR UNIT. INDOOR FAN MOTOR PLUGS - "DO NOT DISCONNECT UNDER LOAD"
 - ON SMALL BASE MODELS LS1 AND LS2 ARE WIRED IN SERIES. LARGE BASE MODELS HAVE LS1 ONLY.
 - INDUCER CAPACITOR AND WIRING ON CERTAIN MODELS ONLY. IF CAP2 IS PRESENT, YELLOW WIRES FROM IGC AND IDM CONNECT ON SAME SIDE OF CAP2.
 - THIS FUSE IS MANUFACTURED BY LITTELFUSE, P/N 257003.
 - THIS FUSE IS MANUFACTURED BY LITTELFUSE, P/N 257005.

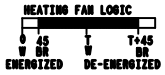
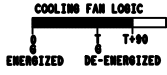

EQUIP_GND

COLOR CODE

- BK BLACK
- BL BLUE
- BR BROWN
- GY GRAY
- GO GREEN
- OP ORANGE
- PK PINK
- RV RED
- VV VIOLET
- WW WHITE
- YY YELLOW

LEGEND

- △ FIELD SPLICE
- TERMINAL (MARKED)
- TERMINAL (UNMARKED)
- SPLICE (IF USED)
- SPLICE (MARKED)
- FACTORY WIRING
- - - FIELD CONTROL WIRING
- - - FIELD POWER WIRING
- - - ACCESSORY OR OPTIONAL WIRING
- - - TO INDICATE COMMON POTENTIAL ONLY; NOT TO REPRESENT WIRING
- BLR BLOWER RELAY
- C CONTACTOR
- CAP 1 CAPACITOR, COMP
- CAP 2 CAPACITOR, INDUCER
- COMP COMPRESSOR MOTOR
- CR COMBUSTION RELAY
- EQUIP EQUIPMENT
- FS FLAME SENSOR
- FU FUSE
- GND GROUND
- GVR GAS VALVE RELAY
- HV TRAN HIGH VOLTAGE TRANSFORMER
- I IGNITOR
- IFB INDOOR FAN BOARD
- IGC INTEGRATED GAS UNIT CONTROLLER
- IDM INDUCED DRAFT MOTOR
- IFM INDOOR FAN MOTOR
- LGPS LOW GAS PRESSURE SWITCH (WHEN USED)
- LS1 PRIMARY LIMIT SWITCH
- LS2 SECONDARY LIMIT SWITCH
- MGV MAIN GAS VALVE
- OTM OUTDOOR FAN MOTOR
- PRS PRESSURE SWITCH
- QT QUADRUPLE TERMINAL
- RS ROLLOUT SWITCH
- TRAN TRANSFORMER
- T-STAT THERMOSTAT

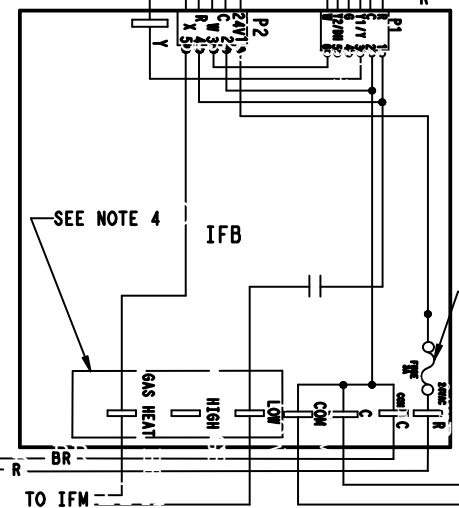
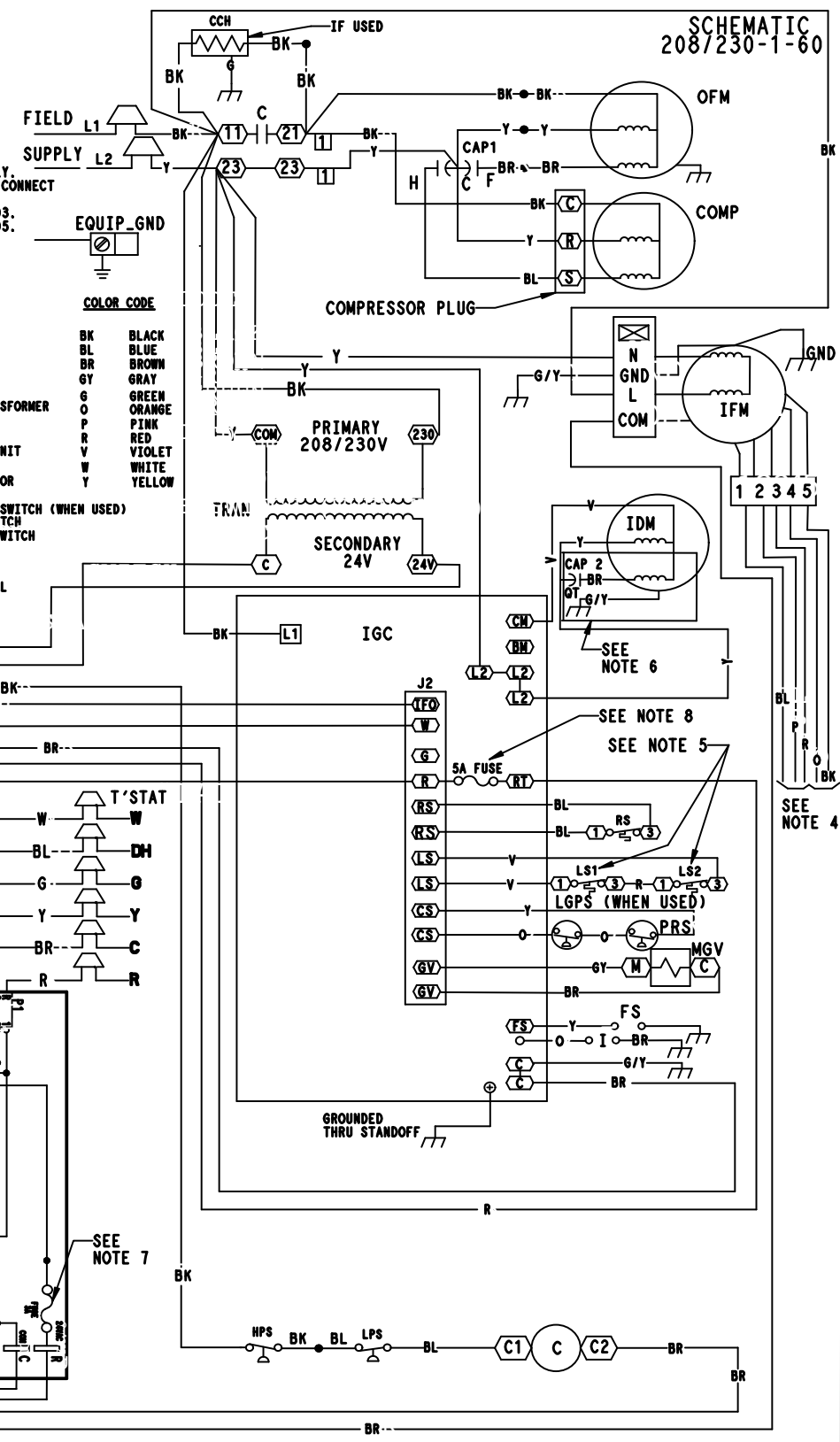

CONTROLS

Operating sequence

Heating – On a call for heating, terminal “W” of the thermostat is energized, starting the induced-draft motor. When the pressure switch senses that the induced-draft motor is moving sufficient combustion air, the burner sequence begins. This function is performed by the integrated gas unit controller (IGC). The indoor (evaporator)-fan motor is energized 45 sec after flame is established. When the thermostat is satisfied and W is de-energized, the burners stop firing and the indoor (evaporator) fan motor shuts off after a 45-sec time-off delay. Please note that the IGC has the capability to automatically reduce the indoor fan motor on delay and increase the indoor fan motor off delay in the event of high duct static and/or partially-clogged filter.

Cooling — When the system thermostat calls for cooling, 24 V is supplied to the “Y1/Y” and “G” terminals of the thermostat. This completes the circuit to the contactor coil (C) and indoor (evaporator) fan relay (IFR). The normally open contacts of energized C close and complete the circuit through compressor motor (COMP) to outdoor (condenser) fan motor (OFM). Both motors start instantly. The set of normally open contacts of energized IFR close and complete the circuit through IFM. The IFM starts instantly.

On the loss of the thermostat call for cooling, 24 V is removed from both the “Y1/Y” and “G” terminals (provided the fan switch is in the “AUTO” position) de-energizing the compressor contactor and opening the contacts supplying power to compressor/OFM. After a 90-second delay, the IFM shuts off. If the thermostat fan selector switch is in the “ON” position, the IFM will run continuously.

NOTE: On units with an anti-cycle device: Once the compressor has started and then stopped, it cannot be restarted again until 5 minutes have elapsed.

ACCESSORIES

ROOF CURBS

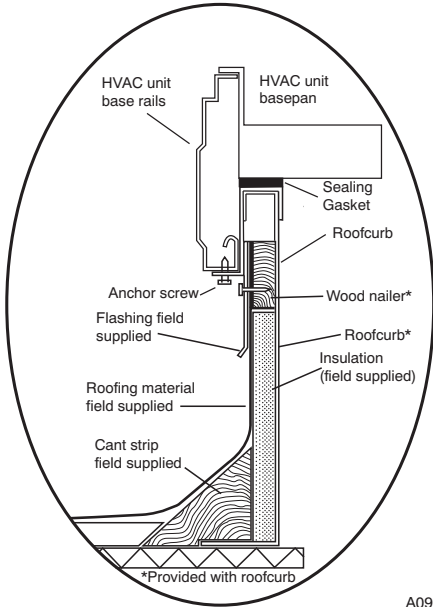

ROOF CURB DETAIL

A09090

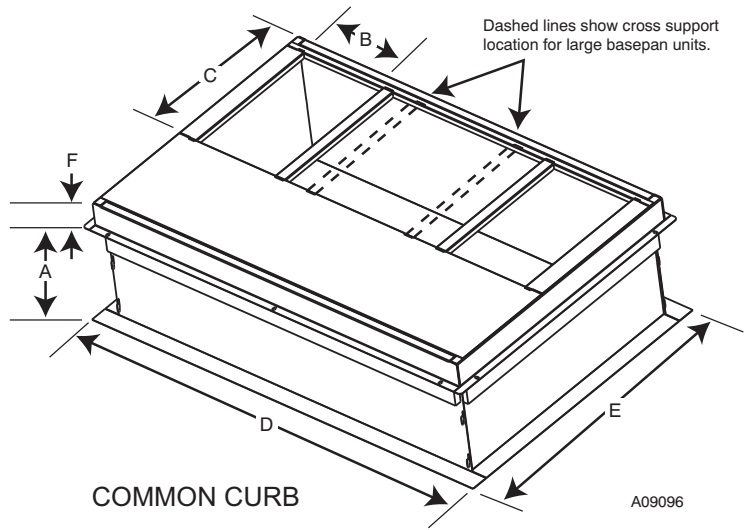

A09096

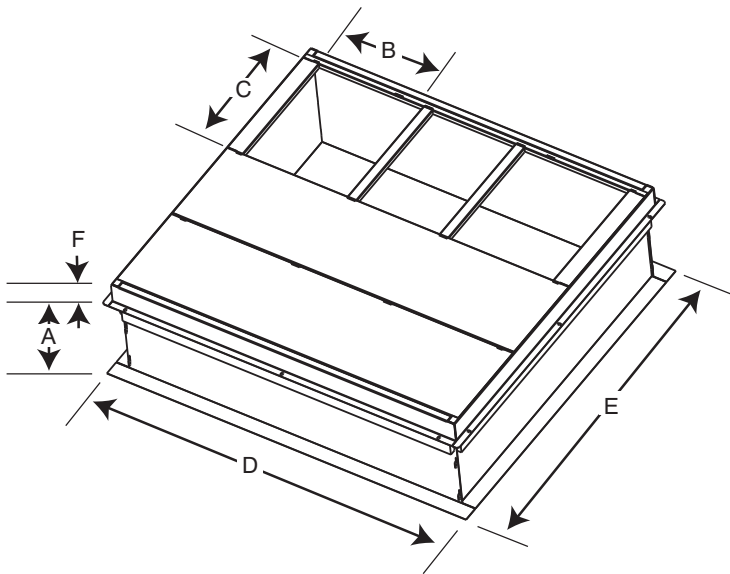

A09095

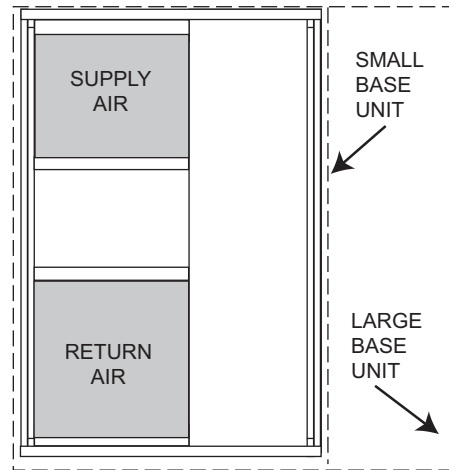

UNIT PLACEMENT ON COMMON CURB

A09094

SMALL OR LARGE BASE UNIT

UNIT SIZE	CATALOG NUMBER	A IN. (mm)	B (small base) IN. (mm)*	B (large base) IN. (mm)*	C IN. (mm)	D IN. (mm)	E IN. (mm)	F IN. (mm)
Small or Large	CPRFCURB010A00	11 (279)	10 (254)	14 (356)	16 (406)	47.8 (1214)	32.4 (822)	2.7 (69)
	CPRFCURB011A00	14 (356)						
Large	CPRFCURB012A00	11 (279)	N/A				43.9 (1116)	
	CPRFCURB013A00	14 (356)						

* Part Numbers CPRFCURB010A00 and CPRFCURB011A00 can be used on both small and large basepan units. The cross supports must be located based on whether the unit is a small basepan or a large basepan.

NOTES:

1. Roof curb must be set up for unit being installed.
2. Seal strip must be applied, as required, to unit being installed.
3. Roof curb is made of 16-gauge steel.
4. Attach ductwork to curb (flanges of duct rest on curb).
5. Insulated panels: 1-in. (25.4 mm) thick fiberglass 1 lb. density.

PGD3 ACCESSORIES (continued)

ROOF CURBS

Model Number	Description	Use With Model Size
CPRFCURB010A00	Roof Curb, 11" High	24 – 60
CPRFCURB011A00	Roof Curb, 14" High	24 – 60
CPRFCURB012A00	Roof Curb, 11" High	42 – 60
CPRFCURB013A00	Roof Curb, 14" High	42 – 60

Note: CPRFCURB010A00 AND CPRFCURB011A00 can be used with 42–60 size units with some overhang.

ADAPTER CURBS*

CPADCURB001A00	Adapter curb for use with NPRFCURB006A00 & NPRFCURB007A00	24 – 36
CPADCURB002A00	Adapter curb for use with NPRFCURB008A00 & NPRFCURB009A00	42 – 60

* Can also be used when replacing other manufacturer's older generation units that contain a composite base without a metal base rail.

CONCENTRIC ADAPTERS – (Use with curb only)

NPCONADP001A00	For 18" round duct (use with curbs CPRFCURB010A00, CPRFCURB011A00)	Small Curb
NPCONADP002A00	For 18" round duct (use with curbs CPRFCURB012A00, CPRFCURB013A00)	Large Curb

CONCENTRIC DIFFUSERS – (Ceiling or under roof)

AXB020CSA*	Step Down Diffuser – Fits 2' x 4' Ceiling Grid (16" round collars for flex conn.)	24 – 42
AXB020CFA*	Flush Mount Diffuser – Fits 2' x 4' Ceiling Grid (16" round collars for flex conn.)	24 – 42
AXB030CSA	Step Down Diffuser – Fits 2' x 4' Ceiling Grid (18" round collars for flex conn.)	24 – 60
AXB030CFA	Flush Mount Diffuser – Fits 2' x 4' Ceiling Grid (18" round collars for flex conn.)	24 – 60

* A field supplied 18" to 16" round reducer required when used with NP concentric adaptor

ECONOMIZERS

Model Number	Description	Use With Model Size
CPECOMZR007A00	Dedicated Vertical Economizer – Internal with solid state controller, gear driven, fully modulating damper, spring return actuator, up to 50% barometric relief, supply and dry bulb outdoor air sensors. Includes filter rack with 1" filters*.	24 – 36
CPECOMZR008A00		42, 48
CPECOMZR009A00		60
CPECOMZR010A00	Dedicated Horizontal Economizer – Internal with solid state controller, fully modulating damper, spring return actuator, supply and dry bulb outdoor air sensor, and low ambient compressor lockout switch included. Includes filter rack with 1–inch filters*.	24 – 36
CPECOMZR011A00		42, 48
CPECOMZR012A00		60
AXB078ENT	Outdoor Enthalpy Control	24 – 60

* Outdoor enthalpy available as field installed accessory; Filter rack and 1" filter, same as CPFILTRK kit

MANUAL FRESH AIR DAMPERS

Model Number	Description	Use With Model Size
CPMANDPR007A00	Manual Outside Air Damper – (Includes filter rack and 1" filter, same as CPFILTRK kit)	24 – 36
CPMANDPR008A00		42, 48
CPMANDPR009A00		60

INTERNAL FILTER RACK and FILTER (shipped with 1" filters)

Model Number	Description	Use With Model Size
CPFILTRK007A00	Internal Filter Rack	24 – 36
CPFILTRK008A00		42, 48
CPFILTRK009A00		60

CRANKCASE HEATER – BELLY BAND TYPE

Model Number	Description	Use With Model Size
NPCRKHTR008A00	240V Crankcase Heater	24 – 36
NPCRKHTR004A00	240V Crankcase Heater	42 – 60

PGD3 ACCESSORIES (continued)

LOW AMBIENT, ANTI-CYCLE TIMER, COMPRESSOR START ASSIST

Model Number	Description	Use With Model Size
CPLOWAMB001A00	Low ambient Control – enables cooling system to operate down to 0 Deg. F by cycling condenser fan on and off	ALL
NRTIMEGD001A00	5 minute anti-cycle timer (Note: many thermostats have inherent anti-cycle timer logic)	ALL
CPHSTART002A00	PTC type compressor start assist	ALL

GAS CONVERSION KITS

Model Number	Description	Use With Model Size
NPLPCONV013A00	Natural Gas to Propane Conversion Kit (0 – 2000')	ALL
NPLPCONV014A00	Natural Gas to Propane Conversion Kit (2001' – 6000')	
NPNGCONV004A00	Propane to Natural Gas Conversion Kit (0 – 2000')	

FLUE DISCHARGE DEFLECTOR

Model Number	Description	Heat Input (BTU/h)
CRFLUEDS001A00	Directs flue gas exhaust 90 degrees upward from current discharge. Designed to allow tighter distances between unit and combustible surfaces. 24 inch Height. AGA certified.	40,000 – 130,000

HAIL GUARDS / COIL PROTECTION

Model Number	Description	Use With Model Size
NAPA00301GR	3/8" spacing dense wire grilles	24
NAPA00501GR	3/8" spacing dense wire grilles	30
NAPA00901GR	3/8" spacing dense wire grilles	36
NAPA00601GR	3/8" spacing dense wire grilles	42
NAPA00801GR	3/8" spacing dense wire grilles	48 – 60

DUCT TRANSITIONS

Model Number	Description	Use With Model Size
NPDUCLG002A00	Square to 14" Round (1 set of 2, use with horizontal duct flanges only)	24 – 48

International Comfort Products, LLC
 Lewisburg, Tennessee 37091 USA
 www.GoICPCommercial.com