



**PGN4**

**Product Specifications**

**14 SEER R-410A PACKAGE GAS / ELECTRIC UNIT, 2½ - 5 TONS  
3-Phase, 208/230V & 460V, 60 Hz**

**REFRIGERATION CIRCUIT**

- Environmentally sound R-410A refrigerant
- Copper tube/aluminum fin condenser and evaporator coils
- Scroll compressors standard on all models

**EASY TO INSTALL AND SERVICE**

- Installs easily on a rooftop or at ground level
- Easy single-panel accessibility for maintenance and installation
- Easily converts to down discharge applications with duct covers provided
- Combination gas heating and electric cooling

**BUILT TO LAST**

- Wire grille
- NOx-approved units available
- Induced-draft combustion and venting
- Pre-painted steel cabinet
- Direct spark ignition
- High efficiency X-13 indoor blower motor on all models
- Aluminized steel tubular heat exchanger
- Vertical condenser fan discharge
- Rust-proof base with integral sloping drain

**LIMITED WARRANTY**

- 15-year heat exchanger limited warranty
- 10-year compressor limited warranty
- 5-year parts limited warranty



As an Energy Star® Partner, International Comfort Products has determined that this product meets the ENERGY STAR® guidelines for energy efficiency.



**UNIT PERFORMANCE DATA**

Model Number	COOLING			HEATING		Voltage 3 Ph - 60 Hz	Unit Dimensions Height x Width x Depth	Operating Weight (lbs)
	Nominal Capacity BTU/h	S.E.E.R	E.E.R.	Input BTU/h	Efficiency AFUE %			
PGN430040H0*A	28,400	14.3	12.0	40,000	80.0	208/230	38 x 48 x 33	319
PGN430060H0*A	28,400	14.3	12.0	60,000	80.0	208/230	38 x 48 x 33	319
PGN436060H0*A	34,200	14.2	12.0	60,000	80.0	208/230	44 x 48 x 33	353
PGN436060L0*A	34,200	14.2	12.0	60,000	80.0	460	44 x 48 x 33	367
PGN436090H0*A	34,200	14.2	12.0	90,000	79.3	208/230	44 x 48 x 33	353
PGN436090L0*A	34,200	14.2	12.0	90,000	79.3	460	44 x 48 x 33	367
PGN442060H0*A	40,500	14.3	12.0	60,000	78.5	208/230	48 x 48 x 44	435
PGN442060L0*A	40,500	14.3	12.0	60,000	78.5	460	48 x 48 x 44	449
PGN442090H0*A	40,500	14.3	12.0	90,000	80.4	208/230	48 x 48 x 44	435
PGN442090L0*A	40,500	14.3	12.0	90,000	80.4	460	48 x 48 x 44	449
PGN448090H0*A	48,000	14.3	12.0	90,000	80.4	208/230	48 x 48 x 44	453
PGN448090L0*A	48,000	14.3	12.0	90,000	80.4	460	48 x 48 x 44	467
PGN448115H0*A	48,000	14.3	12.0	115,000	80.3	208/230	48 x 48 x 44	453
PGN448115L0*A	48,000	14.3	12.0	115,000	80.3	460	48 x 48 x 44	467
PGN448130H0*A	48,000	14.3	12.0	130,000	78.9	208/230	48 x 48 x 44	453
PGN448130L0*A	48,000	14.3	12.0	130,000	78.9	460	48 x 48 x 44	467
PGN460090H0*A	59,000	14.0	12.0	90,000	80.4	208/230	52 x 48 x 44	481
PGN460090L0*A	59,000	14.0	12.0	90,000	80.4	460	52 x 48 x 44	495
PGN460115H0*A	59,000	14.0	12.0	115,000	80.3	208/230	52 x 48 x 44	481
PGN460115L0*A	59,000	14.0	12.0	115,000	80.3	460	52 x 48 x 44	495
PGN460130H0*A	59,000	14.0	12.0	130,000	78.9	208/230	52 x 48 x 44	481
PGN460130L0*A	59,000	14.0	12.0	130,000	78.9	460	52 x 48 x 44	495

\* 0 = Standard Model, 1 = Low NOx California Model

**509 56 3302 00**

**Not yet approved for sale in California (not yet listed with CEC - California Energy Commission)**

UNIT SPECIFICATIONS							
UNIT SIZE	PGN4	30040	30060	36060	36090	42060	42090
<b>NOMINAL CAPACITY (ton)</b>		2-1/2	2-1/2	3	3	3-1/2	3-1/2
<b>SHIPPING WEIGHT lb. (kg)*</b>		373 (169)	373 (169)	407 (185)	407 (185)	497 (225)	497 (225)
<b>COMPRESSORS (Qty)</b>		Scroll (1)					
<b>REFRIGERANT (R-410A) lb. (kg)</b>		7.8 (3.5)	7.8 (3.5)	9.8 (4.4)	9.8 (4.4)	11.0 (5.0)	11.0 (5.0)
<b>REFRIGERANT METERING DEVICE</b>		TXV					
<b>OUTDOOR COIL</b>	Rows...Fins/in.	2...21	2...21	2...21	2...21	2...21	2...21
	Face Area (sq ft)	10.2	10.2	15.25	15.25	19.4	19.4
<b>OUTDOOR FAN</b>	Nominal Cfm	2800	2800	3000	3000	3500	3500
	Diameter in. (mm)	22 (559)	22 (559)	22 (559)	22 (559)	22 (559)	22 (559)
	Motor Hp (Rpm)	1/8 (825)	1/8 (825)	1/8 (825)	1/8 (825)	1/8 (825)	1/8 (825)
<b>INDOOR COIL</b>	Rows...Fins/in.	3...17	3...17	4...15	4...15	3...17	3...17
	Face Area (sq ft)	3.7	3.7	3.7	3.7	4.7	4.7
<b>INDOOR BLOWER</b>							
Nominal Cooling Airflow (Cfm)		1000	1000	1200	1200	1400	1400
Size (in.)		10x10	10x10	11x10	11x10	11x10	11x10
Size (mm.)		254x254	254x254	279.4x254	279.4x254	279.4x254	279.4x254
Motor HP (RPM)		1/2 (1050)	1/2 (1050)	3/4 (1000)	3/4 (1000)	3/4 (1075)	3/4 (1075)
<b>FURNACE SECTION**</b>							
Burner Orifice No. (Qty...Drill Size)							
Natural Gas		2...44	2...38	2...38	3...38	2...38	3...38
Propane Gas		2...55	2...53	2...53	3...53	2...53	3...53
<b>HIGH-PRESSURE SWITCH</b> (psig) Cut-out Reset (Auto)		650 +/- 15 420 +/- 25					
<b>LOW-PRESSURE SWITCH</b> (Liquid Line) (psig) cut-out Reset (auto)		20 +/- 5 45 +/- 10					
<b>RETURN-AIR FILTERS†‡</b> Throwaway Size in. (mm)		20x24x1 (508x610x25)			24x30x1 (610x762x25)		

UNIT SPECIFICATIONS							
UNIT SIZE	PGN4	48090	48115	48130	60090	60115	60130
<b>NOMINAL CAPACITY (ton)</b>		4	4	4	5	5	5
<b>SHIPPING WEIGHT lb (kg)</b>		515 (234)	515 (234)	515 (234)	543 (247)	543 (247)	543 (247)
<b>Compressors (Qty)</b>		Scroll (1)					
<b>Refrigerant (R-410A) lb. (kg.)</b>		10.5 (4.8)	10.5 (4.8)	10.5 (4.8)	14.5 (6.6)	14.5 (6.6)	14.5 (6.6)
<b>Refrigerant Metering Device</b>		TXV					
<b>OUTDOOR COIL</b>	Rows...Fins/in.	2...21	2...21	2...21	2...21	2...21	2...21
	Face Area (sq ft)	19.4	19.4	19.4	23.3	23.3	23.3
<b>OUTDOOR FAN</b>	Nominal Cfm	3500	3500	3500	4200	4200	4200
	Diameter in. (mm)	22 (559)	22 (559)	22 (559)	22 (559)	22 (559)	22 (559)
	Motor Hp (Rpm)	1/4 (1100)	1/4 (1100)	1/4 (1100)	1/4 (1100)	1/4 (1100)	1/4 (1100)
<b>INDOOR COIL</b>	Rows...Fins/in.	3...17	3...17	3...17	4...17	4...17	4...17
	Face Area (sq ft)	5.7	5.7	5.7	5.7	5.7	5.7
<b>INDOOR BLOWER</b>							
Nominal Cooling Airflow (Cfm)		1600	1600	1600	1750	1750	1750
Size (In.)		11x10	11x10	11x10	11x10	11x10	11x10
Size (mm)		279.4x254	279.4x254	279.4x254	279.4x254	279.4x254	279.4x254
Motor HP (RPM)		1.0 (1075)	1.0 (1075)	1.0 (1075)	1.0 (1040)	1.0 (1040)	1.0 (1040)
<b>FURNACE SECTION**</b>							
Burner Orifice No. (Qty...Drill Size)							
Natural Gas		3...38	3...33	3...31	3...38	3...33	3...31
Propane Gas		3...53	3...51	3...49	3...53	3...51	3...49
<b>HIGH-PRESSURE SWITCH</b> (psig) Cut-out Reset (Auto)		650 +/- 15 420 +/- 25					
<b>LOW-PRESSURE SWITCH</b> (Liquid Line) (psig) cut-out Reset (auto)		20 +/- 5 45 +/- 10					
<b>RETURN-AIR FILTERS†‡</b> Throwaway Size in. (mm)		24 x 36 x 1 (610 x 916 x 25)					

\* For 460 volt units add 14 lb (6.35 kg) to the shipping weight.

\*\* Based on altitude of 0 to 2000 ft.

† Required filter sizes shown are based on the larger of the ARI (Air Conditioning and Refrigeration Institute) rated cooling airflow or the heating airflow velocity of 300 ft/minute for throwaway type. Air filter pressure drop for non-standard filters must not exceed 0.08 in. wc.

‡ If using accessory filter rack refer to the filter rack installation instructions for correct filter sizes and quantity.

**UNIT AIRFLOW, Horizontal and Downflow Discharge, 230 Volts, Dry Coil**

Model	Heating Rise Range	Motor Speed	Wire Color	External Static Pressure (Inches Water Column)									
					0.1	0.2	0.3	0.4	0.5	0.6	0.7	0.8	0.9
PGN430040	30 - 60° F (17 - 33° C)	Low	Blue	CFM	741	638	547	415	--	--	--	--	--
				Heating Rise (°F)	41	47	55	NA	NA	NA	NA	NA	NA
				Heating Rise (°C)	23	26	31	NA	NA	NA	NA	NA	NA
		Med-Low	Pink	CFM	898	820	738	662	536	--	--	--	--
				Heating Rise (°F)	34	37	41	46	56	NA	NA	NA	NA
				Heating Rise (°C)	19	20	23	25	31	NA	NA	NA	NA
		Medium <sup>1</sup>	Red	CFM	973	887	823	733	665	538	451	--	--
				Heating Rise (°F)	31	34	37	41	45	56	NA	NA	NA
				Heating Rise (°C)	17	19	20	23	25	31	NA	NA	NA
		Med-High <sup>2</sup>	Orange	CFM	1140	1064	996	915	840	758	687	564	480
				Heating Rise (°F)	NA	NA	30	33	36	40	44	54	NA
				Heating Rise (°C)	NA	NA	17	18	20	22	24	30	NA
		High	Black	CFM	1202	1140	1082	1015	961	881	810	732	631
				Heating Rise (°F)	NA	NA	NA	30	31	34	37	41	48
				Heating Rise (°C)	NA	NA	NA	17	17	19	21	23	27
PGN430060	25 - 55° F (14 - 31° C)	Low	Blue	CFM	741	638	547	415	--	--	--	--	--
				Heating Rise (°F)	NA	NA	NA	NA	NA	NA	NA	NA	NA
				Heating Rise (°C)	NA	NA	NA	NA	NA	NA	NA	NA	NA
		Med-Low	Pink	CFM	898	820	738	662	536	--	--	--	--
				Heating Rise (°F)	49	54	NA	NA	NA	NA	NA	NA	NA
				Heating Rise (°C)	27	30	NA	NA	NA	NA	NA	NA	NA
		Medium	Red	CFM	973	887	823	733	665	538	451	--	--
				Heating Rise (°F)	46	50	54	NA	NA	NA	NA	NA	NA
				Heating Rise (°C)	25	28	30	NA	NA	NA	NA	NA	NA
		Med-High <sup>2</sup>	Orange	CFM	1140	1064	996	915	840	758	687	564	480
				Heating Rise (°F)	39	42	45	49	53	NA	NA	NA	NA
				Heating Rise (°C)	22	23	25	27	29	NA	NA	NA	NA
		High <sup>1</sup>	Black	CFM	1202	1140	1082	1015	961	881	810	732	631
				Heating Rise (°F)	37	39	41	44	46	50	55	NA	NA
				Heating Rise (°C)	21	22	23	24	26	28	30	NA	NA
PGN436060	25 - 55° F (14 - 31° C)	Low <sup>1</sup>	Blue	CFM	1206	1151	1085	1033	961	901	839	769	694
				Heating Rise (°F)	37	39	41	43	46	49	53	NA	NA
				Heating Rise (°C)	20	21	23	24	26	27	29	NA	NA
		Med-Low <sup>2</sup>	Pink	CFM	1369	1317	1262	1208	1152	1095	1037	979	919
				Heating Rise (°F)	32	34	35	37	39	41	43	45	48
				Heating Rise (°C)	18	19	20	20	21	23	24	25	27
		Medium	Red	CFM	1419	1370	1315	1269	1209	1161	1101	1043	984
				Heating Rise (°F)	31	32	34	35	37	38	40	43	45
				Heating Rise (°C)	17	18	19	19	20	21	22	24	25
		Med-High	Orange	CFM	1557	1507	1464	1412	1365	1310	1265	1212	1154
				Heating Rise (°F)	29	29	30	31	33	34	35	37	39
				Heating Rise (°C)	16	16	17	17	18	19	20	20	21
		High	Black	CFM	1599	1553	1505	1460	1410	1361	1310	1262	1203
				Heating Rise (°F)	28	29	30	30	32	33	34	35	37
				Heating Rise (°C)	15	16	16	17	18	18	19	20	21
PGN436090	35 - 65° F (19 - 36° C)	Low	Blue	CFM	1206	1151	1085	1033	961	901	839	769	694
				Heating Rise (°F)	56	59	63	NA	NA	NA	NA	NA	NA
				Heating Rise (°C)	31	33	35	NA	NA	NA	NA	NA	NA
		Med-Low <sup>2</sup>	Pink	CFM	1369	1317	1262	1208	1152	1095	1037	979	919
				Heating Rise (°F)	50	52	54	56	59	62	NA	NA	NA
				Heating Rise (°C)	28	29	30	31	33	35	NA	NA	NA
		Medium	Red	CFM	1419	1370	1315	1269	1209	1161	1101	1043	984
				Heating Rise (°F)	48	50	52	54	56	59	62	65	NA
				Heating Rise (°C)	27	28	29	30	31	33	34	36	NA
		Med-High	Orange	CFM	1557	1507	1464	1412	1365	1310	1265	1212	1154
				Heating Rise (°F)	44	45	46	48	50	52	54	56	59
				Heating Rise (°C)	24	25	26	27	28	29	30	31	33
		High <sup>1</sup>	Black	CFM	1599	1553	1505	1460	1410	1361	1310	1262	1203
				Heating Rise (°F)	43	44	45	47	48	50	52	54	57
				Heating Rise (°C)	24	24	25	26	27	28	29	30	31

- refer to Notes at the end of the chart -

Model	Heating Rise Range	Motor Speed	Wire Color	External Static Pressure (Inches Water Column)									
				0.1	0.2	0.3	0.4	0.5	0.6	0.7	0.8	0.9	
PGN442060	25 - 55° F (14 - 31° C)	Low <sup>1</sup>	Blue	CFM	1295	1234	1182	1126	1075	1016	955	898	857
				Heating Rise (°F)	34	36	38	39	41	44	47	49	52
				Heating Rise (°C)	19	20	21	22	23	24	26	27	29
		Med-Low	Pink	CFM	1345	1282	1235	1194	1140	1095	1027	974	921
				Heating Rise (°F)	33	35	36	37	39	41	43	46	48
				Heating Rise (°C)	18	19	20	21	22	23	24	25	27
		Medium	Red	CFM	1505	1452	1413	1358	1323	1282	1234	1169	1130
				Heating Rise (°F)	30	31	31	33	34	35	36	38	39
				Heating Rise (°C)	16	17	17	18	19	19	20	21	22
		Med-High <sup>2</sup>	Orange	CFM	1545	1492	1449	1411	1362	1313	1278	1231	1188
				Heating Rise (°F)	29	30	31	31	33	34	35	36	37
				Heating Rise (°C)	16	17	17	17	18	19	19	20	21
		High	Black	CFM	1705	1643	1607	1568	1518	1483	1448	1404	1360
				Heating Rise (°F)	26	27	28	28	29	30	31	32	33
				Heating Rise (°C)	14	15	15	16	16	17	17	18	18
PGN442090	35 - 65° F (19 - 36° C)	Low	Blue	CFM	1295	1234	1182	1126	1075	1016	955	898	857
				Heating Rise (°F)	53	55	58	60	63	NA	NA	NA	NA
				Heating Rise (°C)	29	31	32	34	35	NA	NA	NA	NA
		Med-Low	Pink	CFM	1345	1282	1235	1194	1140	1095	1027	974	921
				Heating Rise (°F)	51	53	55	57	60	62	NA	NA	NA
				Heating Rise (°C)	28	29	31	32	33	35	NA	NA	NA
		Medium <sup>1</sup>	Red	CFM	1505	1452	1413	1358	1323	1282	1234	1169	1130
				Heating Rise (°F)	45	47	48	50	51	53	55	58	60
				Heating Rise (°C)	25	26	27	28	29	29	31	32	33
		Med-High <sup>2</sup>	Orange	CFM	1545	1492	1449	1411	1362	1313	1278	1231	1188
				Heating Rise (°F)	44	46	47	48	50	52	53	55	57
				Heating Rise (°C)	24	25	26	27	28	29	30	31	32
		High	Black	CFM	1705	1643	1607	1568	1518	1483	1448	1404	1360
				Heating Rise (°F)	40	41	42	43	45	46	47	48	50
				Heating Rise (°C)	22	23	24	24	25	25	26	27	28
PGN448090	35 - 65° F (19 - 36° C)	Low <sup>1</sup>	Blue	CFM	1445	1389	1341	1281	1236	1189	1139	1072	1027
				Heating Rise (°F)	47	49	51	53	55	57	60	63	NA
				Heating Rise (°C)	26	27	28	29	31	32	33	35	NA
		Med-Low <sup>2</sup>	Pink	CFM	1678	1635	1602	1558	1513	1474	1438	1404	1349
				Heating Rise (°F)	41	42	42	44	45	46	47	48	50
				Heating Rise (°C)	23	23	24	24	25	26	26	27	28
		Medium	Red	CFM	1962	1915	1880	1843	1794	1753	1711	1675	1628
				Heating Rise (°F)	35	36	36	37	38	39	40	41	42
				Heating Rise (°C)	19	20	20	20	21	22	22	23	23
		Med-High	Orange	CFM	2131	2088	2065	2013	1982	1941	1888	1860	1785
				Heating Rise (°F)	NA	NA	NA	NA	NA	35	36	37	38
				Heating Rise (°C)	NA	NA	NA	NA	NA	19	20	20	21
		High	Black	CFM	2461	2409	2339	2286	2192	2140	2062	1968	1874
				Heating Rise (°F)	NA	NA	NA	NA	NA	NA	NA	35	36
				Heating Rise (°C)	NA	NA	NA	NA	NA	NA	NA	19	20
PGN448115	30 - 60° F (17 - 33° C)	Low	Blue	CFM	1445	1389	1341	1281	1236	1189	1139	1072	1027
				Heating Rise (°F)	60	NA	NA	NA	NA	NA	NA	NA	NA
				Heating Rise (°C)	33	NA	NA	NA	NA	NA	NA	NA	NA
		Med-Low <sup>2</sup>	Pink	CFM	1678	1635	1602	1558	1513	1474	1438	1404	1349
				Heating Rise (°F)	52	53	54	56	57	59	60	NA	NA
				Heating Rise (°C)	29	30	30	31	32	33	34	NA	NA
		Medium	Red	CFM	1962	1915	1880	1843	1794	1753	1711	1675	1628
				Heating Rise (°F)	44	45	46	47	48	50	51	52	53
				Heating Rise (°C)	25	25	26	26	27	28	28	29	30
		Med-High <sup>1</sup>	Orange	CFM	2131	2088	2065	2013	1982	1941	1888	1860	1785
				Heating Rise (°F)	41	42	42	43	44	45	46	47	49
				Heating Rise (°C)	23	23	23	24	24	25	26	26	27
		High	Black	CFM	2461	2409	2339	2286	2192	2140	2062	1968	1874
				Heating Rise (°F)	35	36	37	38	40	41	42	44	46
				Heating Rise (°C)	20	20	21	21	22	23	23	25	26

- refer to Notes at the end of the chart -

Model	Heating Rise Range	Motor Speed	Wire Color	External Static Pressure (Inches Water Column)									
				0.1	0.2	0.3	0.4	0.5	0.6	0.7	0.8	0.9	
PGN448130	35 - 65° F (19 - 36° C)	Low	Blue	CFM	1445	1389	1341	1281	1236	1189	1139	1072	1027
				Heating Rise (°F)	NA	NA	NA	NA	NA	NA	NA	NA	NA
				Heating Rise (°C)	NA	NA	NA	NA	NA	NA	NA	NA	NA
		Med-Low <sup>2</sup>	Pink	CFM	1678	1635	1602	1558	1513	1474	1438	1404	1349
				Heating Rise (°F)	57	59	60	62	64	65	NA	NA	NA
				Heating Rise (°C)	32	33	33	34	35	36	NA	NA	NA
		Medium	Red	CFM	1962	1915	1880	1843	1794	1753	1711	1675	1628
				Heating Rise (°F)	49	50	51	52	54	55	56	57	59
				Heating Rise (°C)	27	28	28	29	30	31	31	32	33
		Med-High <sup>1</sup>	Orange	CFM	2131	2088	2065	2013	1982	1941	1888	1860	1785
				Heating Rise (°F)	45	46	47	48	49	50	51	52	54
				Heating Rise (°C)	25	26	26	27	27	28	28	29	30
		High	Black	CFM	2461	2409	2339	2286	2192	2140	2062	1968	1874
				Heating Rise (°F)	39	40	41	42	44	45	47	49	51
				Heating Rise (°C)	22	22	23	23	24	25	26	27	29
PGN460090	35 - 65° F (19 - 36° C)	Low <sup>1</sup>	Blue	CFM	1448	1362	1296	1226	1168	1108	1071	998	905
				Heating Rise (°F)	47	50	52	55	58	61	63	NA	NA
				Heating Rise (°C)	26	28	29	31	32	34	35	NA	NA
		Med-Low	Pink	CFM	1722	1675	1614	1543	1499	1442	1408	1356	1308
				Heating Rise (°F)	39	41	42	44	45	47	48	50	52
				Heating Rise (°C)	22	23	23	24	25	26	27	28	29
		Medium <sup>2</sup>	Red	CFM	1887	1847	1783	1726	1677	1625	1578	1527	1432
				Heating Rise (°F)	36	37	38	39	41	42	43	45	47
				Heating Rise (°C)	20	20	21	22	23	23	24	25	26
		Med-High	Orange	CFM	2055	2008	1958	1927	1900	1768	1685	1581	1458
				Heating Rise (°F)	NA	NA	35	35	36	38	40	43	47
				Heating Rise (°C)	NA	NA	19	20	20	21	22	24	26
		High	Black	CFM	2292	2238	2158	2049	1935	1840	1732	1635	1513
				Heating Rise (°F)	NA	NA	NA	NA	35	37	39	42	45
				Heating Rise (°C)	NA	NA	NA	NA	20	21	22	23	25
PGN460115	30 - 60° F (17 - 33° C)	Low	Blue	CFM	1448	1362	1296	1226	1168	1108	1071	998	905
				Heating Rise (°F)	60	NA	NA	NA	NA	NA	NA	NA	NA
				Heating Rise (°C)	33	NA	NA	NA	NA	NA	NA	NA	NA
		Med-Low	Pink	CFM	1722	1675	1614	1543	1499	1442	1408	1356	1308
				Heating Rise (°F)	50	52	54	56	58	60	NA	NA	NA
				Heating Rise (°C)	28	29	30	31	32	33	NA	NA	NA
		Medium <sup>2</sup>	Red	CFM	1887	1847	1783	1726	1677	1625	1578	1527	1432
				Heating Rise (°F)	46	47	49	50	52	53	55	57	NA
				Heating Rise (°C)	26	26	27	28	29	30	31	32	NA
		Med-High <sup>1</sup>	Orange	CFM	2055	2008	1958	1927	1900	1768	1685	1581	1458
				Heating Rise (°F)	42	43	44	45	46	49	52	55	60
				Heating Rise (°C)	23	24	25	25	25	27	29	31	33
		High	Black	CFM	2292	2238	2158	2049	1935	1840	1732	1635	1513
				Heating Rise (°F)	38	39	40	42	45	47	50	53	57
				Heating Rise (°C)	21	22	22	24	25	26	28	30	32
PGN460130	35 - 65° F (19 - 36° C)	Low	Blue	CFM	1448	1321	1282	1235	1192	1145	1101	1057	1011
				Heating Rise (°F)	NA	NA	NA	NA	NA	NA	NA	NA	NA
				Heating Rise (°C)	NA	NA	NA	NA	NA	NA	NA	NA	NA
		Med-Low	Pink	CFM	1722	1675	1614	1543	1499	1442	1408	1356	1308
				Heating Rise (°F)	56	57	60	62	64	NA	NA	NA	NA
				Heating Rise (°C)	31	32	33	35	36	NA	NA	NA	NA
		Medium <sup>2</sup>	Red	CFM	1887	1847	1783	1726	1677	1625	1578	1527	1432
				Heating Rise (°F)	51	52	54	56	57	59	61	63	NA
				Heating Rise (°C)	28	29	30	31	32	33	34	35	NA
		Med-High <sup>1</sup>	Orange	CFM	2055	2008	1958	1927	1900	1768	1685	1581	1458
				Heating Rise (°F)	47	48	49	50	51	54	57	61	NA
				Heating Rise (°C)	26	27	27	28	28	30	32	34	NA
		High	Black	CFM	2292	2238	2158	2049	1935	1840	1732	1635	1513
				Heating Rise (°F)	42	43	45	47	50	52	56	59	64
				Heating Rise (°C)	23	24	25	26	28	29	31	33	35

\* Air delivery values are without air filter and are for dry coil (See Pressure Drop tables). Deduct field-supplied air filter pressure drop and wet coil pressure drop to obtain external static pressure available for ducting.

1. Factory-shipped heating speed
  2. Factory-shipped cooling speed
- NA - Not allowed for heating speed

## FILTER PRESSURE DROP

FILTER SIZE	CFM																		
	500	600	700	800	900	1000	1100	1200	1300	1400	1500	1600	1700	1800	1900	2000	2100	2200	2300
20 x 24 x 1	—	—	—	—	0.09	0.10	0.11	0.13	0.14	0.15	0.16	—	—	—	—	—	—	—	—
24 x 30 x 1	—	—	—	0.04	0.05	0.06	0.07	0.07	0.08	0.09	0.1	0.11	0.12	0.13	0.14	0.15	0.16	0.17	0.18
24 x 36 x 1	—	—	—	—	—	—	—	0.06	0.07	0.07	0.08	0.09	0.09	0.10	0.11	0.12	0.13	0.14	0.14

Minimum Filter Requirements:

20 x 24 x 1 = PGN430

20 x 30 x 1 = PGN436, PGN442

24 x 36 x 1 = PGN448, PGN460

## WET COIL PRESSURE DROP (IN. W.C.)

MODEL SIZE	STANDARD CFM (S.C.F.M.)															
	600	700	800	900	1000	1100	1200	1300	1400	1500	1600	1700	1800	1900	2000	
30	-	-	0.12	0.15	0.19	0.23	0.27	-	-	-	-	-	-	-	-	
36	-	-	-	-	0.07	0.11	0.18	0.26	0.35	-	-	-	-	-	-	
42	-	-	-	-	-	-	0.04	0.07	0.10	0.15	0.21	-	-	-	-	
48	-	-	-	-	-	-	-	-	0.11	0.14	0.17	0.22	0.28	-	-	
60	-	-	-	-	-	-	-	-	-	-	0.10	0.17	0.23	0.31	0.36	

## UNIT ELECTRICAL SPECIFICATIONS

MODEL NUMBER	Nominal V- PH- HZ	Voltage Range		Compressor		OFM	IFM	IDM	Power Supply				
		Min.	Max.	RLA	LRA	FLA	FLA	FLA	MCA	MOCP			
PGN430040	208/230-3-60	187	253	8.3	58.0	0.9	4.1	0.7	15.4	20			
PGN430060				8.3	58.0	0.9	4.1	1.7	15.4	20			
PGN436060				9.0	71.0	0.9	6.0	1.7	18.2	25			
PGN436090				9.0	71.0	0.9	6.0	1.5	18.2	25			
PGN442060				13.5	88.0	0.9	6.0	1.7	23.8	35			
PGN442090				13.5	88.0	0.9	6.0	0.7	23.8	35			
PGN448090				13.7	83.1	1.5	7.6	0.7	26.2	35			
PGN448115				13.7	83.1	1.5	7.6	1.7	26.2	35			
PGN448130				13.7	83.1	1.5	7.6	0.5	26.2	35			
PGN460090				16.0	110.0	1.9	7.6	0.7	29.5	40			
PGN460115				16.0	110.0	1.9	7.6	1.7	29.5	40			
PGN460130				16.0	110.0	1.9	7.6	0.5	29.5	40			
PGN436060				460-3-60	414	506	5.6	38.0	0.6	6.0	0.7	10.6	15
PGN436090							5.6	38.0	0.6	6.0	0.3	10.6	15
PGN442060	6.0	44.0	0.6				6.0	0.7	11.1	15			
PGN442090	6.0	44.0	0.6				6.0	0.3	11.1	15			
PGN448090	6.2	41.0	0.9				7.6	0.3	12.4	15			
PGN448115	6.2	41.0	0.9				7.6	0.7	12.4	15			
PGN448130	6.2	41.0	0.9				7.6	0.3	12.4	15			
PGN460090	7.8	52.0	1.0				7.6	0.3	14.6	20			
PGN460115	7.8	52.0	1.0				7.6	0.7	14.6	20			
PGN460130	7.8	52.0	1.0				7.6	0.3	14.6	20			

### LEGEND

- FLA -- Full Load Amps
- LRA -- Locked Rotor Amps
- MCA -- Minimum Circuit Amps
- MOCP -- Maximum Overcurrent Protection
- RLA -- Rated Load Amps



EXAMPLE: Supply voltage is 230-3-60.



- AB = 228 v
- BC = 231 v
- AC = 227 v

$$\begin{aligned} \text{Average Voltage} &= \frac{228 + 231 + 227}{3} \\ &= \frac{686}{3} \\ &= 229 \end{aligned}$$

Determine maximum deviation from average voltage.

- (AB) 229 - 228 = 1 v
- (BC) 231 - 229 = 2 v
- (AC) 229 - 227 = 2 v

Maximum deviation is 2 v.

Determine percent of voltage imbalance

$$\begin{aligned} \% \text{ Voltage Imbalance} &= 100 \times \frac{2}{229} \\ &= 0.8\% \end{aligned}$$

This amount of phase imbalance is satisfactory as it is below the maximum allowable 2%.

**IMPORTANT:** If the supply voltage phase imbalance is more than 2%, contact your local electric utility company immediately.

### NOTES:

1. In compliance with NEC (National Electrical Code) requirements for multimotor and combination load equipment (refer to NEC Articles 430 and 440), the overcurrent protective device for the unit shall be Power Supply fuse. The CGA (Canadian Gas Association) units may be fuse or circuit breaker.
2. Minimum wire size is based on 60 C copper wire. If other than 60 C wire is used, or if length exceeds wire length in table, determine size from NEC.
3. Unbalanced 3-Phase Supply Voltage  
*Never operate a motor where a phase imbalance in supply voltage is greater than 2%.* Use the following formula to determine the percentage of voltage imbalance

$$\% \text{ Voltage imbalance} = 100 \times \frac{\text{max voltage deviation from average voltage}}{\text{average voltage}}$$

**PGN430 COOLING PERFORMANCE**

EVAPORATOR AIR		CONDENSER ENTERING AIR TEMPERATURES °F (°C)																							
CFM / BF	Ewb	75 (23.9)			85 (29.4)			95 (65)			105 (40.6)			115 (46.1)			125 (51.7)								
		Capacity BTU/h x 1000	Total System kW		Capacity BTU/h x 1000	Total System kW		Capacity BTU/h x 1000	Total System kW		Capacity BTU/h x 1000	Total System kW		Capacity BTU/h x 1000	Total System kW		Capacity BTU/h x 1000	Total System kW							
875 / 0.03	57	28.46	1.82	26.75	2.05	24.89	2.31	22.87	2.60	20.70	2.91	18.40	3.25	28.46	1.82	26.75	2.05	24.89	2.31	22.87	2.60	20.70	2.91	18.40	3.25
	62	29.16	1.82	27.05	2.05	24.89	2.31	22.86	2.60	20.70	2.91	18.39	3.25	29.16	1.82	27.05	2.05	24.89	2.31	22.86	2.60	20.70	2.91	18.39	3.25
	63*	29.82	1.82	27.65	2.06	25.25	2.31	22.60	2.59	19.73	2.89	16.70	3.21	29.82	1.82	27.65	2.06	25.25	2.31	22.60	2.59	19.73	2.89	16.70	3.21
	67	32.32	1.81	30.19	2.06	27.78	2.33	25.09	2.63	22.19	2.93	19.08	3.26	32.32	1.81	30.19	2.06	27.78	2.33	25.09	2.63	22.19	2.93	19.08	3.26
1000 / 0.04	72	35.18	1.82	33.30	2.06	31.09	2.33	28.50	2.63	25.62	2.97	22.41	3.33	35.18	1.82	33.30	2.06	31.09	2.33	28.50	2.63	25.62	2.97	22.41	3.33
	57	29.83	1.85	28.06	2.10	26.12	2.37	24.01	2.65	21.74	2.97	19.33	3.31	29.83	1.85	28.06	2.10	26.12	2.37	24.01	2.65	21.74	2.97	19.33	3.31
	62	30.00	1.85	28.06	2.10	26.11	2.37	24.00	2.65	21.74	2.97	19.33	3.31	30.00	1.85	28.06	2.10	26.11	2.37	24.00	2.65	21.74	2.97	19.33	3.31
	63*	30.52	1.85	28.31	2.10	25.84	2.36	23.13	2.64	20.21	2.94	17.36	3.26	30.52	1.85	28.31	2.10	25.84	2.36	23.13	2.64	20.21	2.94	17.36	3.26
1125 / 0.05	67	32.96	1.85	30.84	2.09	28.40	2.37	25.67	2.67	22.69	2.99	18.54	3.31	32.96	1.85	30.84	2.09	28.40	2.37	25.67	2.67	22.69	2.99	18.54	3.31
	72	35.69	1.85	33.82	2.10	31.62	2.37	29.05	2.67	26.12	3.01	22.85	3.37	35.69	1.85	33.82	2.10	31.62	2.37	29.05	2.67	26.12	3.01	22.85	3.37
	57	30.95	1.88	29.15	2.13	27.15	2.41	24.97	2.71	22.62	3.03	20.12	3.37	30.95	1.88	29.15	2.13	27.15	2.41	24.97	2.71	22.62	3.03	20.12	3.37
	62	30.94	1.88	29.15	2.13	27.15	2.41	24.96	2.71	22.62	3.03	20.12	3.37	30.94	1.88	29.15	2.13	27.15	2.41	24.96	2.71	22.62	3.03	20.12	3.37
1125 / 0.05	63*	31.04	1.88	28.81	2.13	26.30	2.40	23.56	2.68	20.65	2.99	18.05	3.32	31.04	1.88	28.81	2.13	26.30	2.40	23.56	2.68	20.65	2.99	18.05	3.32
	67	33.41	1.88	31.32	2.13	28.87	2.40	26.11	2.71	23.10	3.04	20.11	3.37	33.41	1.88	31.32	2.13	28.87	2.40	26.11	2.71	23.10	3.04	20.11	3.37
	72	36.05	1.89	34.17	2.13	31.98	2.41	29.41	2.71	26.48	3.05	20.11	3.41	36.05	1.89	34.17	2.13	31.98	2.41	29.41	2.71	26.48	3.05	20.11	3.41

– refer to Legend, Notes, and Formulas at the end of the chart –

**PGN436 COOLING PERFORMANCE**

EVAPORATOR AIR		CONDENSER ENTERING AIR TEMPERATURES °F (°C)																		
		75 (23.9)			85 (29.4)			95 (35)			105 (40.6)			115 (46.1)			125 (51.7)			
		CFM / BF	Ewb	Capacity BTU/h x 1000		Total System kW	Capacity BTU/h x 1000		Total System kW	Capacity BTU/h x 1000		Total System kW	Capacity BTU/h x 1000		Total System kW	Capacity BTU/h x 1000		Total System kW		
Total	Sens			Total	Sens		Total	Sens		Total	Sens		Total	Sens						
		57	33.74	33.74	2.21	31.86	31.86	2.47	29.86	29.86	2.76	27.71	27.71	3.08	25.42	25.42	3.42	23.00	23.00	3.79
		62	34.63	29.69	2.22	32.34	29.18	2.48	29.93	29.78	2.76	27.71	27.71	3.08	25.42	25.42	3.42	23.00	23.00	3.79
	1050 / 0.02	63*	35.42	24.26	2.23	33.09	23.73	2.49	30.56	23.09	2.77	27.82	22.33	3.08	24.86	21.44	3.40	21.70	20.43	3.75
		67	38.42	25.21	2.23	36.04	24.74	2.50	33.47	24.17	2.80	30.67	23.47	3.13	27.66	22.66	3.47	24.44	21.74	3.83
		72	42.11	20.41	2.24	39.77	19.99	2.51	37.26	19.49	2.81	34.52	18.88	3.14	31.52	18.16	3.50	28.25	17.30	3.89
		57	35.34	35.34	2.28	33.39	33.39	2.55	31.30	31.30	2.84	29.06	29.06	3.16	26.68	26.68	3.50	24.14	24.14	3.88
		62	35.58	32.00	2.28	33.39	33.39	2.55	31.30	31.30	2.84	29.06	29.06	3.16	26.67	26.67	3.50	24.14	24.14	3.88
	1200 / 0.03	63*	36.26	25.97	2.28	33.86	25.44	2.55	31.25	24.80	2.83	28.44	24.04	3.14	25.41	23.15	3.47	22.21	22.09	3.82
		67	39.24	26.97	2.28	36.82	26.54	2.55	34.20	26.00	2.85	31.34	25.31	3.18	28.25	24.49	3.54	24.96	23.55	3.90
		72	42.80	21.39	2.29	40.39	20.99	2.56	37.86	20.53	2.86	35.10	19.97	3.19	32.08	19.29	3.55	28.76	18.46	3.95
		57	36.70	36.70	2.33	34.69	34.69	2.60	32.53	32.53	2.90	30.20	30.20	3.23	27.73	27.73	3.59	25.09	25.09	3.96
		62	36.70	36.70	2.33	34.69	34.69	2.60	32.52	32.52	2.90	30.20	30.20	3.23	27.72	27.72	3.59	25.09	25.09	3.96
	1350 / 0.03	63*	36.89	27.59	2.33	34.44	27.08	2.60	31.78	26.44	2.90	28.92	25.68	3.21	25.66	24.75	3.54	22.78	22.78	3.90
		67	39.83	28.62	2.33	37.38	28.23	2.60	34.73	27.73	2.90	31.84	27.07	3.23	28.71	26.25	3.60	25.40	25.24	3.97
		72	43.27	22.31	2.35	40.81	21.92	2.62	38.24	21.49	2.92	35.47	20.97	3.25	32.45	20.35	3.61	29.11	19.57	4.00

**PGN442 COOLING PERFORMANCE**

EVAPORATOR AIR		CONDENSER ENTERING AIR TEMPERATURES °F (°C)																		
		75 (23.9)			85 (29.4)			95 (35)			105 (40.6)			115 (46.1)			125 (51.7)			
		CFM / BF	Ewb	Capacity BTU/h x 1000		Total System kW	Capacity BTU/h x 1000		Total System kW	Capacity BTU/h x 1000		Total System kW	Capacity BTU/h x 1000		Total System kW	Capacity BTU/h x 1000		Total System kW		
Total	Sens			Total	Sens		Total	Sens		Total	Sens		Total	Sens						
		57	39.18	39.18	2.56	36.42	36.42	2.90	33.76	33.76	3.28	31.03	31.03	3.70	28.30	28.30	4.17	25.52	25.52	4.68
		62	40.87	35.89	2.57	37.42	34.32	2.91	34.11	32.73	3.28	31.02	31.02	3.70	28.29	28.29	4.17	25.52	25.52	4.68
	1225 / 0.03	63*	42.42	29.68	2.58	38.64	28.15	2.92	35.18	28.75	3.29	31.48	25.22	3.70	27.69	23.63	4.16	23.81	21.97	4.65
		67	46.44	30.98	2.60	42.97	29.69	2.95	39.60	28.41	3.33	36.16	27.09	3.75	32.63	25.72	4.22	28.89	24.22	4.72
		72	50.49	25.03	2.63	47.40	24.14	2.98	43.83	22.99	3.36	40.24	21.81	3.79	36.59	20.60	4.26	32.85	19.35	4.77
		57	41.90	41.90	2.62	38.93	38.93	2.96	36.19	36.19	3.34	33.33	33.33	3.77	30.43	30.43	4.24	27.48	27.48	4.75
		62	42.97	39.09	2.63	39.22	37.25	2.96	36.18	36.18	3.34	33.33	33.33	3.77	30.42	30.42	4.24	27.48	27.48	4.75
	1400 / 0.04	63*	43.96	31.91	2.63	40.21	30.40	2.97	36.67	28.96	3.35	32.87	27.39	3.76	28.97	25.74	4.22	24.93	23.97	4.71
		67	47.54	33.05	2.65	43.97	31.76	2.99	40.50	30.45	3.38	36.96	29.10	3.80	33.35	27.69	4.27	29.66	26.21	4.78
		72	51.19	26.03	2.68	48.08	25.20	3.03	44.60	24.15	3.41	40.91	22.95	3.84	37.20	21.73	4.31	33.39	20.47	4.83
		57	44.01	44.01	2.67	41.03	41.03	3.02	38.13	38.13	3.40	35.17	35.17	3.83	32.15	32.15	4.30	29.08	29.08	4.82
		62	44.16	43.83	2.67	41.03	41.03	3.02	38.12	38.12	3.40	35.17	35.17	3.83	32.15	32.15	4.30	29.08	29.08	4.82
	1575 / 0.05	63*	44.80	33.83	2.68	41.29	32.44	3.02	37.88	31.05	3.40	34.03	29.43	3.82	30.01	27.70	4.27	25.94	25.82	4.77
		67	48.33	34.96	2.69	44.73	33.72	3.04	41.17	32.38	3.42	37.57	30.99	3.85	33.89	29.55	4.31	30.16	28.02	4.83
		72	51.62	26.90	2.73	48.32	25.98	3.08	45.11	25.19	3.46	41.35	23.97	3.89	37.59	22.76	4.36	33.74	21.50	4.88

- refer to Legend, Notes, and Formulas at the end of the chart -



**PGN448 COOLING PERFORMANCE**

EVAPORATOR AIR		CONDENSER ENTERING AIR TEMPERATURES °F (°C)																		
		75 (23.9)			85 (29.4)			95 (35)			105 (40.6)			115 (46.1)			125 (51.7)			
		CFM / BF	Ewb	Capacity BTU/h x 1000		Total System kW	Capacity BTU/h x 1000		Total System kW	Capacity BTU/h x 1000		Total System kW	Capacity BTU/h x 1000		Total System kW	Capacity BTU/h x 1000		Total System kW		
Total	Sens			Total	Sens		Total	Sens		Total	Sens		Total	Sens						
		57	48.44	48.44	3.27	45.41	45.41	3.60	42.35	42.35	3.93	39.25	39.25	4.28	36.07	36.07	4.64	34.18	34.18	4.51
		62	50.26	44.05	3.27	46.66	42.03	3.60	43.09	40.02	3.94	39.52	37.98	4.28	36.06	36.06	4.64	34.18	34.18	4.51
	1400 / 0.03	63*	51.28	36.22	3.27	47.58	34.38	3.60	43.89	32.55	3.94	40.18	30.72	4.28	36.42	28.87	4.64	34.30	27.73	4.51
		67	55.09	37.36	3.27	51.09	35.48	3.60	47.11	33.62	3.94	43.10	31.75	4.29	39.02	29.87	4.65	34.78	27.92	5.01
		72	60.45	30.62	3.26	56.04	28.88	3.60	51.64	27.15	3.95	47.22	25.42	4.30	42.71	23.67	4.67	40.74	22.84	4.59
		57	50.64	50.64	3.33	47.39	47.39	3.66	44.12	44.12	3.99	40.81	40.81	4.34	38.97	38.97	4.15	33.81	33.81	5.06
		62	51.54	47.47	3.33	47.82	45.31	3.66	44.17	43.97	3.99	40.81	40.81	4.34	38.97	38.97	4.15	33.81	33.81	5.06
	1600 / 0.04	63*	52.46	38.62	3.33	48.59	36.69	3.66	44.75	34.79	4.00	40.90	32.88	4.34	38.86	31.74	4.15	32.95	28.95	5.05
		67	56.33	39.90	3.32	52.15	37.94	3.66	48.00	36.00	4.00	43.84	34.06	4.35	39.61	32.09	4.71	35.22	30.06	5.07
		72	61.77	32.23	3.32	57.17	30.43	3.66	52.59	28.64	4.00	48.00	26.86	4.36	43.32	25.05	4.72	38.45	23.18	5.08
		57	52.49	52.49	3.39	49.05	49.05	3.71	45.59	45.59	4.05	42.10	42.10	4.40	40.22	40.22	4.23	34.71	34.71	5.12
		62	52.66	50.62	3.39	49.04	49.04	3.71	45.59	45.59	4.05	42.09	42.09	4.40	38.49	38.49	4.76	36.60	36.60	4.65
	1800 / 0.04	63*	53.37	40.93	3.39	49.37	38.93	3.71	45.40	36.94	4.05	41.44	34.96	4.40	37.42	32.94	4.75	33.28	30.85	5.11
		67	57.27	42.36	3.38	52.95	40.32	3.71	48.67	38.30	4.06	44.39	36.28	4.41	42.36	35.14	4.26	35.55	32.11	5.12
		72	62.77	33.77	3.37	58.02	31.92	3.71	53.29	30.08	4.06	48.56	28.24	4.42	43.75	26.38	4.78	38.76	24.47	5.14

**PGN460 COOLING PERFORMANCE**

EVAPORATOR AIR		CONDENSER ENTERING AIR TEMPERATURES °F (°C)																		
		75 (23.9)			85 (29.4)			95 (35)			105 (40.6)			115 (46.1)			125 (51.7)			
		CFM / BF	Ewb	Capacity BTU/h x 1000		Total System kW	Capacity BTU/h x 1000		Total System kW	Capacity BTU/h x 1000		Total System kW	Capacity BTU/h x 1000		Total System kW	Capacity BTU/h x 1000		Total System kW		
Total	Sens			Total	Sens		Total	Sens		Total	Sens		Total	Sens						
		57	62.31	62.31	3.82	57.76	57.76	4.31	53.24	53.24	4.85	48.73	48.73	5.45	44.19	44.19	6.12	39.54	39.54	6.85
		62	64.27	54.67	3.84	59.06	52.70	4.32	53.94	50.71	4.86	48.90	48.64	5.45	44.19	44.19	6.12	39.54	39.54	6.85
	1750 / 0.03	63*	65.55	44.79	3.85	60.20	42.97	4.38	54.93	41.12	4.87	49.72	39.25	5.46	44.51	37.32	6.12	39.24	35.29	6.84
		67	70.43	46.23	3.90	64.67	44.38	4.38	59.00	42.51	4.92	53.38	40.61	5.51	47.75	38.65	6.17	42.05	36.58	6.89
		72	77.30	37.72	3.97	70.97	35.99	4.45	64.73	34.24	4.99	58.53	32.45	5.59	52.31	30.59	6.24	45.98	28.62	6.96
		57	65.10	65.10	3.93	60.26	60.26	4.42	55.46	55.46	4.96	50.67	50.67	5.57	45.84	45.84	6.24	40.90	40.90	6.97
		62	65.85	59.03	3.94	60.50	56.90	4.42	55.46	55.46	4.96	50.67	50.67	5.57	45.84	45.84	6.24	40.90	40.90	6.97
	2000 / 0.04	63*	66.98	47.84	3.95	61.43	45.94	4.43	55.96	44.02	4.97	50.56	42.07	5.56	45.18	40.06	6.22	39.75	37.95	6.95
		67	71.92	49.46	4.00	65.94	47.53	4.48	60.07	45.59	5.02	54.26	43.62	5.82	48.44	41.58	6.28	42.56	39.43	6.99
		72	78.87	39.76	4.07	72.31	37.97	4.55	65.85	36.16	5.09	59.44	34.32	5.69	53.01	32.41	6.34	46.48	30.38	7.06
		57	67.45	67.45	4.04	62.36	62.36	4.53	57.30	57.30	5.07	52.27	52.27	5.68	47.19	47.19	6.35	42.00	42.00	7.08
		62	67.45	67.45	4.04	62.35	62.35	4.53	57.30	57.30	5.07	52.27	52.27	5.68	47.19	47.19	6.35	41.99	41.99	7.08
	2250 / 0.04	63*	68.06	50.78	4.04	62.35	48.81	4.53	56.73	48.83	5.06	51.19	44.81	5.66	45.68	42.72	6.32	40.13	40.51	7.05
		67	73.04	52.59	4.09	66.90	50.60	4.58	60.86	48.59	5.12	54.90	46.55	5.72	48.94	44.43	6.38	42.93	42.19	7.09
		72	80.04	41.72	4.16	73.30	39.89	4.65	66.66	38.03	5.19	60.09	36.14	5.79	53.50	34.18	6.44	46.81	32.11	7.16

\* 63°F Ewb is at 75°F entering dry bulb – Tennessee Valley Authority [TVA] rating conditions; all others at 80°F entering dry bulb.

LEGEND: BF — Bypass Factor Ewb — Entering Wet Bulb kW — Total Unit Power Input SHC — Sensible Heat Capacity (x1000 Btu/h) TC — Total Capacity (x1000 Btu/h) (net)

NOTES: 1. Ratings are net; they account for the effects of the evaporator fan motor power and heat.

2. Direct interpolation is permissible. Do not extrapolate.

3. The following formulas may be used:

$$t_{Ldb} = t_{Edb} - \frac{\text{Sensible Capacity (BTU/h)}}{1.10 \times \text{cfm}}$$

$$h_{Lwb} = h_{Ewb} - \frac{\text{Total Capacity (BTU/h)}}{4.5 \times \text{cfm}}$$

t<sub>Lwb</sub> = Wet bulb temperature corresponding to enthalpy of air leaving evaporator coil (h<sub>Lwb</sub>)  
 h<sub>Lwb</sub> = Wet bulb temperature corresponding to enthalpy of air entering evaporator coil (h<sub>Lwb</sub>)

4. The SHC is based on 80°F Edb temperature of air entering evaporator coil.

Below 80°F Edb, subtract (corr factor x cfm) from SHC.  
 Above 80°F Edb, add (corr factor x cfm) to SHC. Correction Factor = 1.10 x (1 + BF) x (Edb + 80).

Where: h<sub>Ewb</sub> = Enthalpy of air entering evaporator coil

# ACCESSORIES

## ROOF CURBS

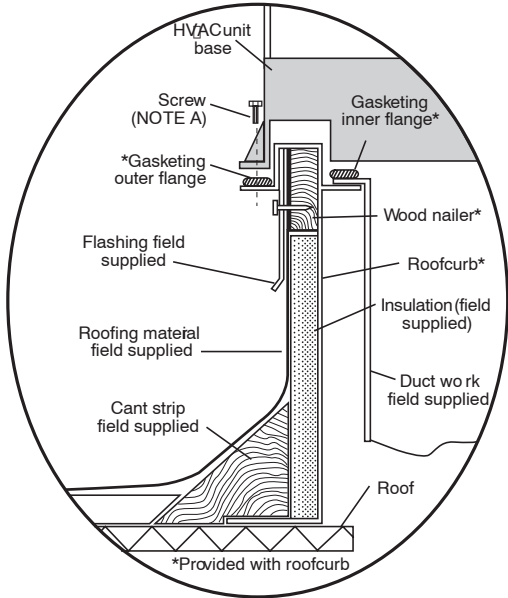

**Roof Curb for Small Cabinet**

Note A: When unit mounting screw is used, retainer bracket must also be used.

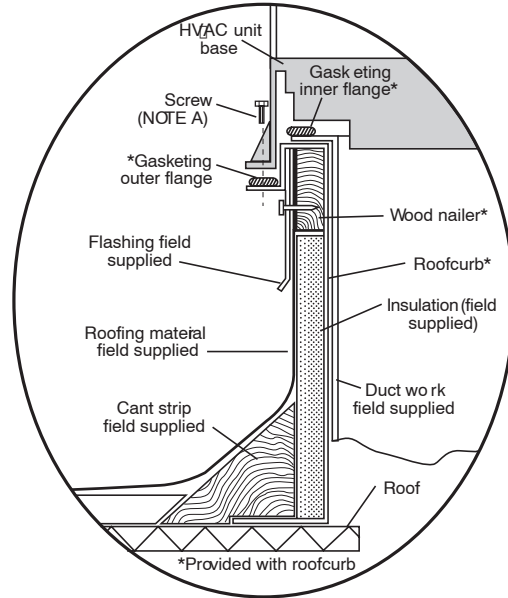

**Roof Curb for Large Cabinet**

Note A: When unit mounting screw is used, retainer bracket must also be used.

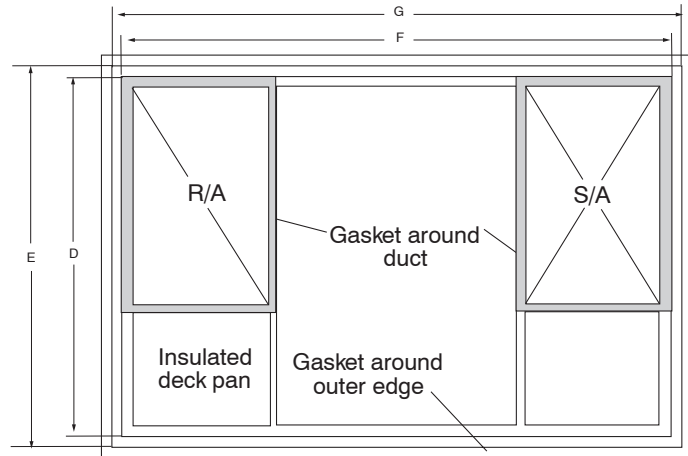
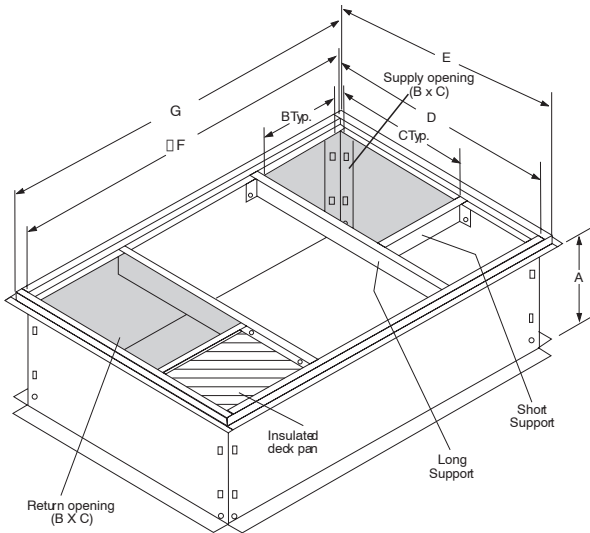

UNIT SIZE	MODEL NUMBER	A IN. [MM]	B IN. [MM]	C IN. [MM]	D IN. [MM]	E IN. [MM]	F IN. [MM]	G IN. [MM]
30, 36	NPRFCURB006A00	8 [203]	11 [279]	16-1/2 [419]	28-3/4 [730]	30-3/8 [771]	44-5/16 [1126]	45-15/16 [1167]
	NPRFCURB007A00	14 [356]	11 [279]	16-1/2 [419]	28-3/4 [730]	30-3/8 [771]	44-5/16 [1126]	45-15/16 [1167]
42, 48, 60	NPRFCURB008A00	8 [203]	16-3/16 [411]	17-3/8 [441]	40-1/4 [1022]	41-15/16 [1065]	44-7/16 [1129]	46-1/16 [1169]
	NPRFCURB009A00	14 [356]	16-3/16 [411]	17-3/8 [441]	40-1/4 [1022]	41-15/16 [1065]	44-7/16 [1129]	46-1/16 [1169]

**Notes:**

1. Seal strip must be applied as required to unit being installed.
2. Roof curb is made of 16 gauge steel.
3. Attach ductwork to curb (flanges of duct rest on curb).
4. Insulated panels: 1-in. thick fiberglass 1 lb. density.
5. When unit mounting screw is used (see Note A), a retainer bracket must be used as well. This bracket must also be used when required by code for hurricane or seismic conditions. This bracket is available through Micrometl.

**ACCESSORIES (continued)**

**ECONOMIZERS (ALL FULLY MODULATING)**

Part Number	Application	Control	Use With Model Size
NPECOMZR003A00	Horizontal, convertible to Downflow	Dry Bulb (Enthalpy Control optional)	30
NPECOMZR004A00			36, 42
NPECOMZR006A00			48, 60

All Economizers include Filter Racks but do not include filters.

**MANUAL FRESH AIR DAMPERS (use in DOWNFLOW application only) \***

Model Number	Control	Use With Model Size
NPMANDPR004A00	Manual	30
NPMANDPR005A00		36, 42
NPMANDPR006A00		48, 60

\* Unit must have internal filters to protect evaporator coil when Fresh Air Damper is installed.  
All Manual Fresh Air Dampers shipped with Filter Racks but without Filters.

**FILTER RACK and FILTER (shipped with 1" filters)**

Model Number	Application	Filter Size	Use With Model Size
NPFILTRK004A00	Horizontal or Downflow	12" x 20" x 1" (quan. 2) or 12" x 20" x 2" (quan. 1) <b>PLUS</b> 10" x 20" x 2" (quan.1)	30
NPFILTRK005A00		12" x 24" x 1" or 2" (3 required)	36, 42
NPFILTRK006A00		12" x 24" x 1" or 2" (3 required)	48, 60

**CONCENTRIC ADAPTER**

Model Number	Description	Use With Model Size
AXB030CTA	Adapts downflow openings thru the curb into round duct (18" dia.)	ALL

**CONCENTRIC DIFFUSER**

Model Number	Description	Use With Model Size
AXB030CSA	STEP DOWN - Adapts round duct (18" dia.) to ceiling diffuser	ALL
AXB030CFA	FLUSH MOUNT - Adapts round duct (18" dia.) to ceiling diffuser	ALL

**SQUARE to ROUND TRANSITION**

Model Number	Round Size	Square Size	Use With Model Size
NPDUFCFLG002A00	14"	14" x 16"	ALL

**ANTI-CYCLE TIMER**

Model Number	Description	Use With Model Size
NRTIMEGD001A00	5 minute anti-cycle timer (Note: many thermostats have inherent anti-cycle timer logic)	ALL

**CRANKCASE HEATER**

Model Number	Description	Use With Model Size
NPCRKHTR004A00	Belly-band type electric heater	ALL

**GAS CONVERSION KITS**

Model Number	Description	Heat Input (BTU/h)	Elevation above Sea Level
NPLPCONV011A00	Natural Gas to Propane	40,000 - 130,000	0' - 2,000'
NPLPCONV012A00	Natural Gas to Propane		2,000' - 6000'
NPNGCONV003A00	Propane to Natural Gas	40,000 - 130,000	0' - 2,000'

**FLUE DISCHARGE DEFLECTOR**

Model Number	Description	Heat Input (BTU/h)	Use With Model Size
NRFLUEDS001A00	Vertical flue, spaced away from unit cabinet	40,000 - 130,000	ALL

**UNIT DIMENSIONS, model sizes 30, 36**

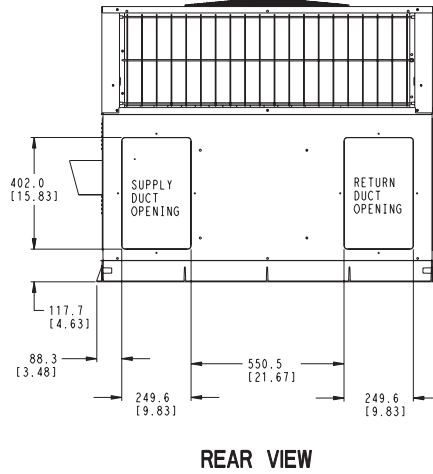
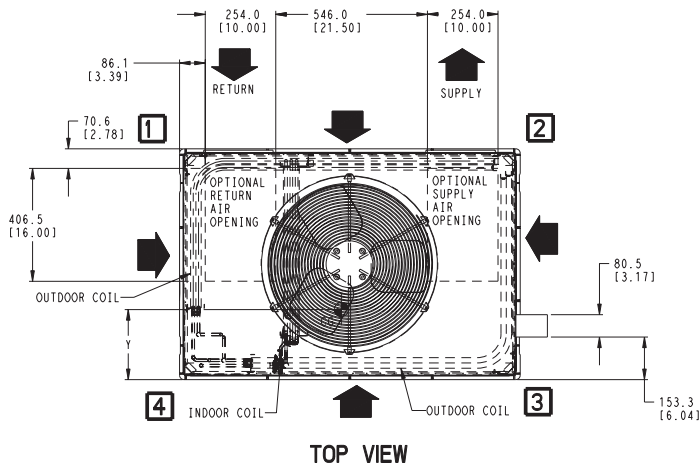

**REQUIRED CLEARANCES TO COMBUSTIBLE MATL.**

	MILLIMETERS [IN]
TOP OF UNIT.....	355.6 [14.00]
DUCT SIDE OF UNIT.....	50.8 [2.00]
SIDE OPPOSITE DUCTS.....	355.6 [14.00]
BOTTOM OF UNIT.....	12.7 [0.50]
FLUE PANEL.....	914.4 [36.00]

**NEC. REQUIRED CLEARANCES.**

	MILLIMETERS [IN]
BETWEEN UNITS, POWER ENTRY SIDE.....	1066.8 [42.00]
UNIT AND UNGROUNDED SURFACES, POWER ENTRY SIDE.....	914.0 [36.00]
UNIT AND BLOCK OR CONCRETE WALLS AND OTHER GROUNDED SURFACES, POWER ENTRY SIDE.....	1066.8 [42.00]

**REQUIRED CLEARANCE FOR OPERATION AND SERVICING**

	MILLIMETERS [IN]
EVAP. COIL ACCESS SIDE.....	914.0 [36.00]
POWER ENTRY SIDE.....	1066.8 [42.00]
(EXCEPT FOR NEC REQUIREMENTS)	
UNIT TOP.....	1219.2 [48.00]
SIDE OPPOSITE DUCTS.....	914.0 [36.00]
DUCT PANEL.....	304.8 [12.00]*

\*MINIMUM DISTANCES: IF UNIT IS PLACED LESS THAN 304.8 [12.00] FROM WALL SYSTEM, THEN SYSTEM PERFORMANCE MAYBE COMPROMISED.

DIMENSIONS IN [ ] ARE IN INCHES

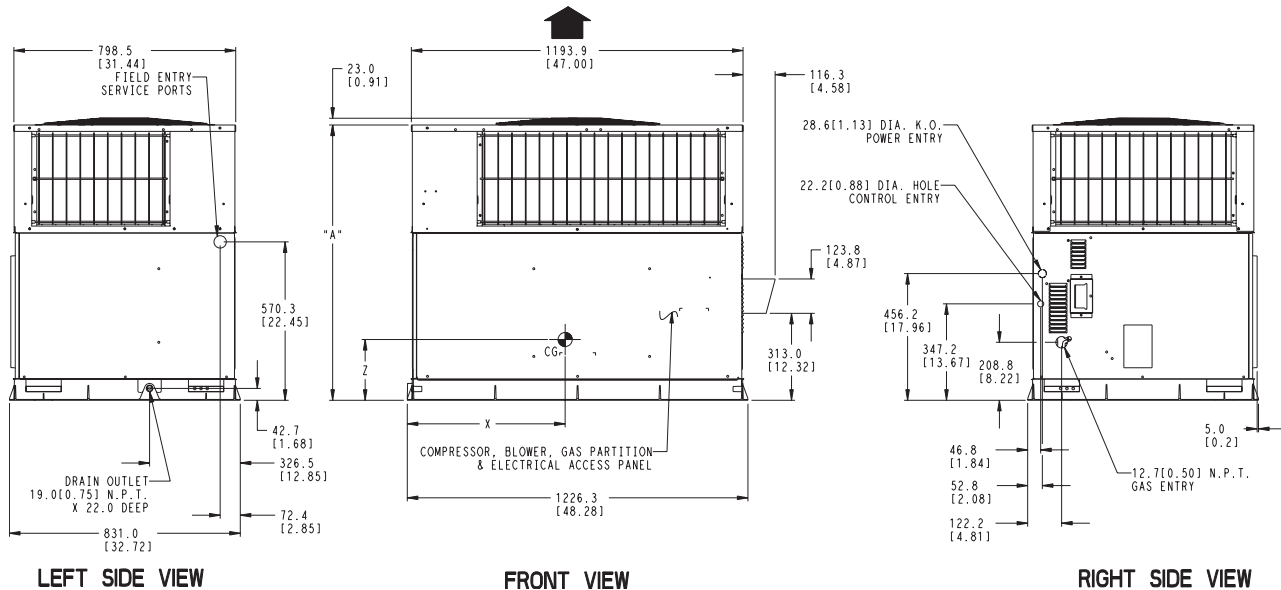

Model Size	UNIT HEIGHT	CENTER OF GRAVITY			
	inches [mm]	inches [mm]			
	A	X	Y	Z	
30	37.02 [940]	23.6 [599.4]	15.8 [401.3]	15.7 [398.8]	
36	43.02 [1093]	25.0 [635]	15.9 [403.9]	16.0 [406.4]	

## UNIT DIMENSIONS, model sizes 42, 48, 60

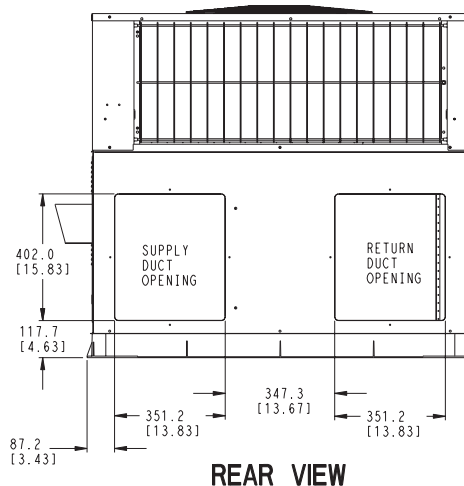
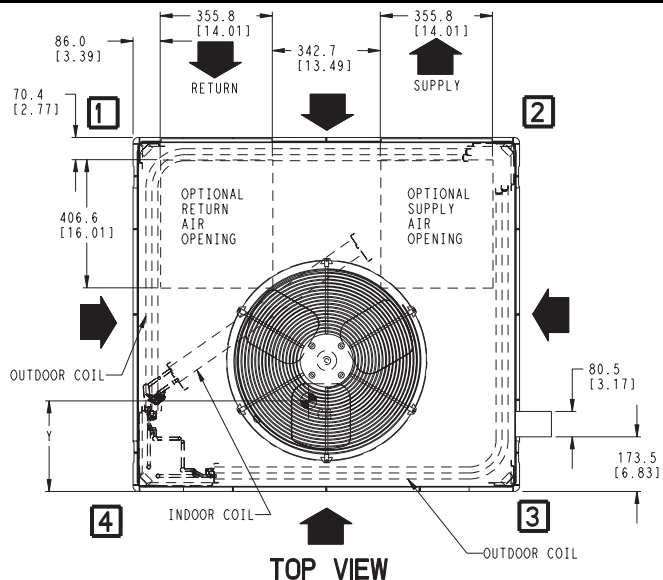

### REQUIRED CLEARANCES TO COMBUSTIBLE MATL.

	MILLIMETERS [IN]
TOP OF UNIT.....	355.6 [14.00]
DUCT SIDE OF UNIT.....	50.8 [2.00]
SIDE OPPOSITE DUCTS.....	355.6 [14.00]
BOTTOM OF UNIT.....	12.7 [0.50]
FLUE PANEL.....	914.4 [36.00]

### NEC. REQUIRED CLEARANCES.

	MILLIMETERS [IN]
BETWEEN UNITS, POWER ENTRY SIDE.....	1066.8 [42.00]
UNIT AND UNGROUNDED SURFACES, POWER ENTRY SIDE.....	914.0 [36.00]
UNIT AND BLOCK OR CONCRETE WALLS AND OTHER GROUNDED SURFACES, POWER ENTRY SIDE.....	1066.8 [42.00]

### REQUIRED CLEARANCE FOR OPERATION AND SERVICING

	MILLIMETERS [IN]
EVAP. COIL ACCESS SIDE.....	914.0 [36.00]
POWER ENTRY SIDE.....	1066.8 [42.00]
(EXCEPT FOR NEC REQUIREMENTS)	
UNIT TOP.....	1219.2 [48.00]
SIDE OPPOSITE DUCTS.....	914.0 [36.00]
DUCT PANEL.....	304.8 [12.00]

\*MINIMUM DISTANCES: IF UNIT IS PLACED LESS THAN 304.8 [12.00] FROM WALL SYSTEM, THEN SYSTEM PERFORMANCE MAYBE COMPROMISED.

DIMENSIONS IN [ ] ARE IN INCHES

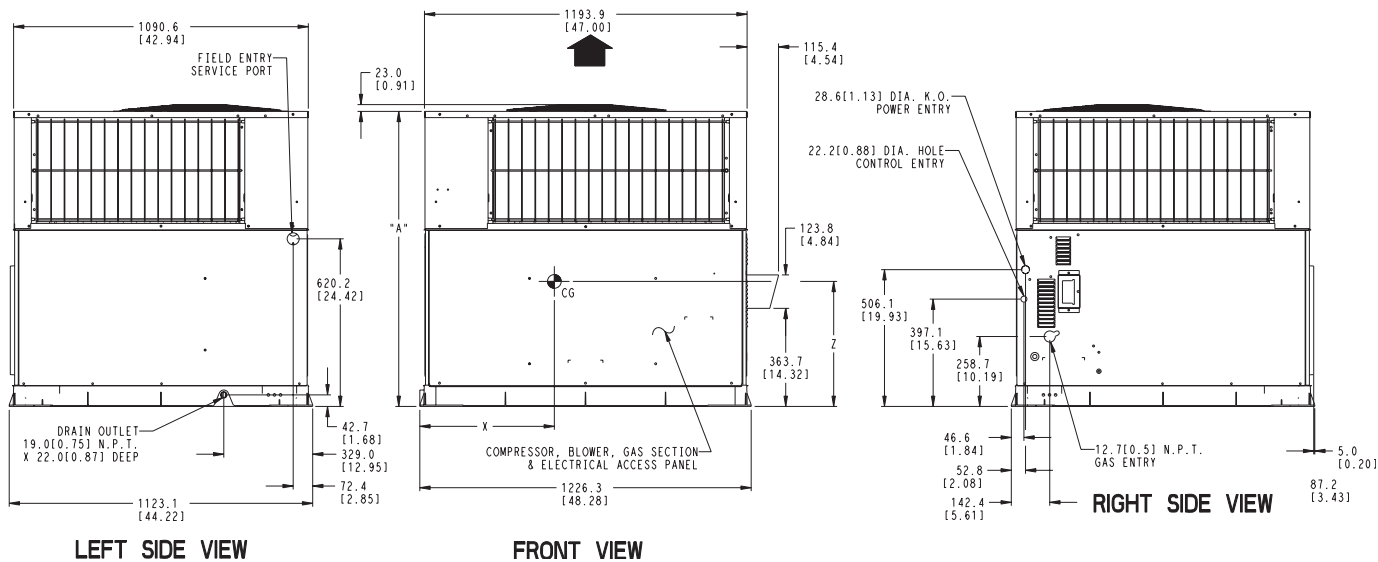

Model Size	UNIT HEIGHT	CENTER OF GRAVITY		
	inches [mm]	inches [mm]		
	A	X	Y	Z
42	46.98 [1193]	25.5 [647.7]	21.0 [533.4]	17.6 [447.0]
48	46.98 [1193]	25.7 [652.8]	21.8 [553.7]	18.0 [457.2]
60	50.98 [1295]	25.8 [655.3]	22.0 [558.8]	20.0 [508.0]

## GUIDE SPECIFICATIONS

### CABINET

Unit cabinet shall be constructed of phosphated, zinc-coated, pre-painted steel capable of with-standing 500 hours in salt spray. Normal service shall be through a single removable cabinet panel. The unit shall be constructed on a rust proof unit base that has an externally trapped, integrated sloped drain.

Evaporator fan compartment top surface shall be insulated with a minimum 1/2-in. (12.7mm) thick, flexible fiberglass insulation, coated on the air side and retained by adhesive and mechanical means. The evaporator wall sections will be insulated with a minimum semi-rigid foil-faced board capable of being wiped clean. Aluminum foil-faced fiberglass insulation shall be used in the entire indoor air cavity section.

### COOLING SECTION

The unit is factory charged and operationally ready upon delivery. The unit refrigerant circuit has a high efficiency scroll compressor with internal overload protection, and copper tube / aluminum fin evaporator and condenser coils. The unit is designed for cooling operation to 40° F (4° C) and will be capable of being wired for field installed economizer type accessories.

### COILS

The evaporator and condenser coils are fabricated with aluminum fins mechanically bonded to copper tubing. Both coils are pressure tested prior to assembly into the unit and electronically leak tested after assembly into the unit.

### CONDENSER FAN

The unit has a single direct-drive propeller-fan / motor assembly. The assembly is mounted directly to a vertical-discharge grille that is easily removed for service. Motors are 1100 RPM with sleeve or ball bearings and internal overload protection.

### EVAPORATOR BLOWER

All units have a direct-drive X-13 evaporator blower motor as a standard. The direct-drive evaporator blower motor has sleeve bearings and internal overload protection.

### HEATING SECTION

The gas-fired heating section features an induced draft blower for combustion air. The unit has an tubular aluminized steel heat exchanger located on the discharge air side of the blower. The system uses in-shot burners ignited by a direct spark ignition system, protected by both a high heat limit switch and flame roll-out switch. The induced draft blower motor is interlocked with a pressure switch safety device.

## CORNER WEIGHTS and RIGGING DETAILS

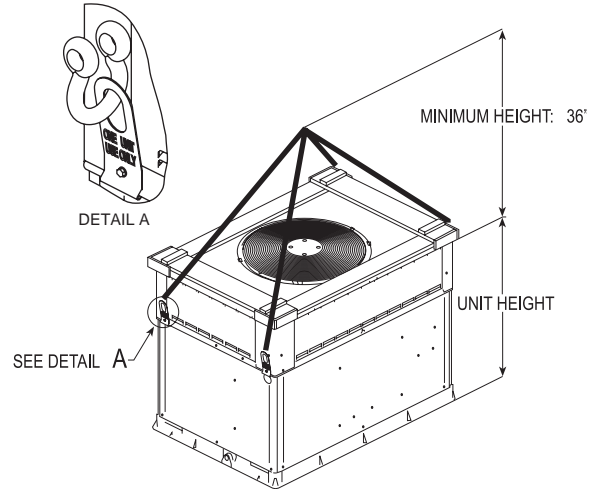
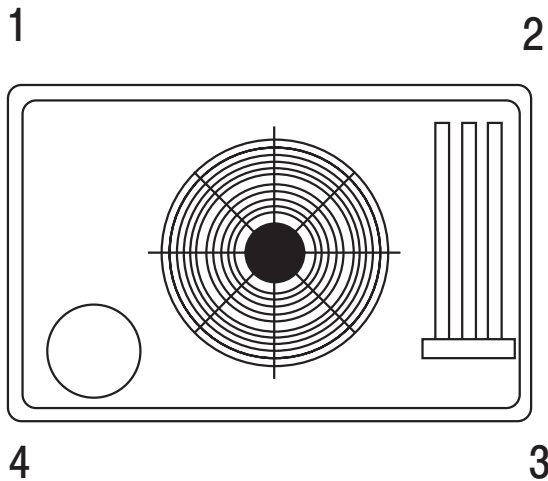

CORNER WEIGHTS (SMALL CABINET)					CORNER WEIGHTS (LARGE CABINET)						
Model Size	30		36		Model Size	42		48		60	
	lbs	kg	lbs	kg		lbs	kg	lbs	kg	lbs	kg
Operating Weight	319	144.7	353	160.1	Operating Weight	435	197.3	453	205.5	481	218.2
Corner Weight 1	65	29.5	49	22.2	Corner Weight 1	62.8	28.5	67.3	30.5	68.7	31.2
Corner Weight 2	90	40.8	106.5	48.3	Corner Weight 2	166.7	75.6	171.2	77.7	184	83.5
Corner Weight 3	85	38.6	71.5	32.4	Corner Weight 3	89.9	40.8	94.4	42.8	94.9	43.0
Corner Weight 4	79	35.8	126	57.2	Corner Weight 4	115.6	52.4	120.1	54.5	133.4	60.5
Shipping Weight	373	169.2	407	184.6	Shipping Weight	497	225.4	515	233.6	543	246.3

MODEL NOMENCLATURE										
<b>MODEL SERIES</b>	<b>P</b>	<b>G</b>	<b>N</b>	<b>4</b>	<b>36</b>	<b>000</b>	<b>H</b>	<b>00</b>	<b>A</b>	<b>1</b>
P = Package										
G = Gas/Electric										
N = R-410A										
4 = 14										
30 = 30,000 BTUH = 2.5 Tons										
36 = 36,000 BTUH = 3 Tons										
42 = 42,000 BTUH = 3.5 Tons										
48 = 48,000 BTUH = 4 Tons										
60 = 60,000 BTUH = 5 Tons										
040 = 40,000 BTUH										
060 = 60,000 BTUH										
090 = 90,000 BTUH										
115 = 115,000 BTUH										
130 = 130,000 BTUH										
H = 208/230-3-60										
L = 460-3-60										
00 = Standard										
01 = Low Nox										
Sales Model Digit										
Engineering Digit										