



PHJ4

Product Specifications

Up to 14.5 SEER, PACKAGE HEAT PUMP UNIT, 2 to 4 TONS 208/230 Volt, 1-phase, 60 Hz

REFRIGERATION CIRCUIT

- Environmentally sound R-410A refrigerant
- Liquid refrigerant filter driers
- Copper tube/aluminum fin condenser and evaporator coils

EASY TO INSTALL AND SERVICE

- Light weight, compact construction ideal for manufactured housing and residential applications
- Hand holds built into the unit base pan
- Compact, fully self-contained, electric cooling unit with horizontal supply and return ducts
- Easy panel accessibility for maintenance and installation
- Accessory electric heaters with single point connections
- Designed to be serviced from both the side and front

BUILT TO LAST

- Vibration isolation provides quiet operation. Compressors have internal over current protection
- Direct-drive multi-speed, blower motor standard on all models
- No-rust base pan with integrated drain pan standard on all units
- Durable pre-painted steel cabinet
- Louvered coil enclosure for protection against vandalism and hail damage
- Aerodynamic fan blade design reduces the overall sound
- All models available with optional factory installed tin-coated copper evaporator coil.
(These models are identified with letters TP in the 11th and 12th positions in the model numbers)

LIMITED WARRANTY*

- 10 year parts limited warranty (including compressor and coils) with timely registration
- 5 years parts limited warranty if not registered within 90 days of original installation

* See warranty certificate for complete details and restrictions



Use of the AHRI Certified TM Mark indicates a manufacturer's participation in the program. For verification of certification for individual products, go to www.ahridirectory.org.



As an Energy Star® Partner, International Comfort Products has determined that this product meets the ENERGY STAR® guidelines for energy efficiency.



UNIT PERFORMANCE DATA							
Model Number	COOLING			HEATING		Unit Dimensions Height x Width x Depth inches (mm)	Operating Weight lbs (kg)
	Net Capacity BTU/h @ 95°F(35°C)	SEER	EER	Net Capacity BTU/h @ 47°F(8.3°C)	HSPF		
PHJ424000K000A	24,000	14.50	11.50	23,400	8.0	30-1/8 x 51 x 32 (765 x 1295 x 813)	253 (115)
PHJ424000KTP0A	24,000	14.50	11.50	23,400	8.0		253 (115)
PHJ430000K000A	29,800	14.50	11.50	28,600	8.0	34-1/8 x 51 x 32 (867 x 1295 x 813)	283 (128)
PHJ430000KTP0A	29,800	14.50	11.50	28,600	8.0		283 (128)
PHJ436000K000A	36,000	14.50	11.50	34,400	8.0	34-1/8 x 51 x 32 (867 x 1295 x 813)	285 (130)
PHJ436000KTP0A	36,000	14.50	11.50	34,400	8.0		285 (130)
PHJ442000K000A	42,000	14.50	11.50	40,000	8.0	42-1/8 x 51 x 32 (1070 x 1295 x 813)	339 (154)
PHJ442000KTP0A	42,000	14.50	11.50	40,000	8.0		339 (154)
PHJ448000K000A	46,500	14.00	11.50	45,000	8.0	42-1/8 x 51 x 32 (1070 x 1295 x 813)	358 (163)
PHJ448000KTP0A	46,500	14.00	11.50	45,000	8.0		358 (163)

AHRI* CAPACITIES

Cooling Capacities and Efficiencies

UNIT SIZE	NOMINAL TONS	STANDARD CFM	NET COOLING CAPACITY AT 95°F (35°C) (Btuh)	EER†	SEER**
024	2	800	24,000	11.50	14.50
030	2.5	1000	29,800	11.50	14.50
036	3	1200	36,000	11.50	14.50
042	3.5	1400	42,000	11.50	14.50
048	4	1600	46,500	11.50	14.00

Heat Pump Heating Capacities and Efficiencies

UNIT SIZE	NET HEATING CAPACITY AT 47°F (8.3°C) (Btuh)	COP @ 17°F (-8.3°C)	NET HEATING CAPACITY AT 17°F (-8.3°C) (Btuh)	COP @ 17°F (-8.3°C)	HSPF**
024	23,400	3.7	13,400	2.4	8.0
030	28,600	3.7	15,600	2.4	8.0
036	34,400	3.5	20,200	2.4	8.0
042	40,000	3.5	23,400	2.4	8.0
048	45,000	3.5	26,600	2.3	8.0

LEGEND

dB---Sound Levels (decibels)

db—Dry Bulb

SEER—Seasonal Energy Efficiency Ratio

wb—Wet Bulb

COP---Coefficient of Performance

* Air Conditioning Heating & Refrigeration Institute

† At "A" conditions--80°F (26.7°C) indoor db/67°F (19.4°C) indoor wb & 95°F (35°C) outdoor db.

** Rated in accordance with U.S. Government DOE Department of Energy) test procedures and/or AHRI Standards 210/240.

Notes:

1. Ratings are net values, reflecting the effects of circulating fan heat.

Ratings are based on:

Cooling Standard: 80°F (26.7°C) db, 67°F wb (19.4°C) indoor entering---air temperature and 95°F db (35°C) outdoor entering---air temperature.

2. Before purchasing this appliance, read important energy cost and efficiency information available from your retailer.



A-Weighted Sound Power Level (dBA)

UNIT SIZE	STANDARD RATING (dBA)	TYPICAL OCTAVE BAND SPECTRUM (dBA without tone adjustment)						
		125	250	500	1000	2000	4000	8000
24	73	54.4	54.9	58.8	67.5	53.7	48.5	39.4
30	75	55.4	63.9	62.8	59.0	54.7	45.5	37.9
36	74	60.4	58.9	62.8	63.0	58.7	52.5	45.4
42	79.5	59.9	64.4	69.3	68.0	65.2	63.0	60.4
48	75.6	59.9	64.4	64.8	65.0	59.7	55.5	48.9

PHYSICAL DATA

UNIT SIZE	024	030	036	042	048
NOMINAL CAPACITY (ton)	2	2.5	3	3.5	4
SHIPPING WEIGHT (lb)	312	333	334	388	407
(kg)	142	151	152	177	185
COMPRESSOR TYPE	SCROLL				
REFRIGERANT	R-410A				
REFRIGERANT QUANTITY (lb)	7.00	7.20	6.30	9.10	7.70
QUANTITY (kg)	3.18	3.27	2.86	4.13	3.49
OUTDOOR METERING DEVICE	TXV	Piston			TXV
ORIFICE OD (in.)	—	0.049	0.057	0.059	—
(mm)	—	1.245	1.448	1.499	—
OUTDOOR COIL					
ROWS...FINS/in.	2...20	2...20	2...20	2...20	2...20
FACE AREA (sq. ft)	9.1	10.2	10.2	13.0	15.5
OUTDOOR FAN					
NOMINAL AIRFLOW (cfm)	2000	2000	2800	3100	3100
DIAMETER (in.)	20	20	20	20	20
DIAMETER (mm)	508	508	508	508	508
MOTOR HP (RPM)	1/8 (825)	1/8 (825)	1/4 (1100)	1/4 (1100)	1/4 (1100)
INDOOR METERING DEVICE	Piston				TXV
ORIFICE OD (in.)	0.059	0.059	0.067	0.076	—
(mm)	1.499	1.499	1.702	1.9304	—
INDOOR COIL					
ROWS...FINS/in.	3...12	3...14	3...12	3...14	3...14
FACE AREA (sq. ft)	4.3	4.3	4.9	4.9	4.9
INDOOR BLOWER					
NOMINAL COOLING AIRFLOW (cfm)	800	1000	1200	1400	1600
NOMINAL SIZE D x L (in.)	10 x 8	11 x 9	11 x 9	11 x 9	11 x 9
(mm)	254 x 203	279 x 229	279 x 229	279 x 229	279 x 229
MOTOR (HP)	1/3	1/3	1/2	1/2	3/4
HIGH-PRESSURE SWITCH (psig)	650 +/- 15				
CUTOUT	420 +/- 25				
RESET (AUTO)	20 +/- 5				
LOW-PRESSURE SWITCH (psig)	45 +/- 10				
CUTOUT					
RESET (AUTO)					
RETURN-AIR FILTERS					
THROWAWAY (in.)	20x20x1	24x30x1		24x36x1	
(mm)	508x508x25	610x762x25		610x914x25	

*Required filter sizes shown are based on the AHRI (Air Conditioning, Heating & Refrigeration Institute) rated airflow at a velocity of 300 ft/min (91 m) for throwaway type or 450 ft/min (137 m) for high capacity type. Recommended filters are 1-in. (25 mm) thick.

OPTIONS AND ACCESSORIES

ITEM	DESCRIPTION	FACTORY INSTALLED OPTION	FIELD INSTALLED ACCESSORY
Coil Options	Base unit with tin plated indoor coil hairpins	X	
Compressor Start Kit	Compressor Start Kit assists compressor start-up by providing additional starting torque.		X
Corporate Thermostats	Thermostats provide control for the system heating and cooling functions.		X
Crankcase Heater	Crankcase Heater provides anti-floodback protection for low-load cooling applications.		X*
Electric Heaters	Electric Heat Supplement		X
Low Ambient Kit	Low Ambient Kit (Motormaster II Control) allows the use of mechanical cooling down to outdoor temperatures as low as 0°F (-18°C) when properly installed.		X
Time Guard II	Automatically prevents the compressor from restarting for at least 4 minutes and 45 seconds after shutdown of the compressor. Not required when a corporate programmable thermostat is applied.		X

Refer to Price Pages for available accessories.

Accessory Electric Heater Usage

CATALOG ORDERING NO.	NOMINAL CAPACITY (kW)	CIRCUIT BREAKER (Yes/No)	STAGES	USED WITH SIZES				
				024	030	036	042	048
CPHEATER125A0*	3.8 / 5.0	No	1	√	√	√	√	√
CPHEATER126A0*	3.8 / 5.0	Yes	1	√	√	√	√	√
CPHEATER127A0*	5.6 / 7.5	No	2	√				
CPHEATER128A0*	5.6 / 7.5	Yes	2	√	√	√	√	√
CPHEATER129A0*	7.5 / 10.0	No	2	NONE				
CPHEATER130A0*	7.5 / 10.0	Yes	2	√	√	√	√	√
CPHEATER131A0*	11.3 / 15.0	Yes	2			√	√	√
CPHEATER132A0*	15.0 / 20.0	Yes	2					√

√ Approved combination

Multiplication Factors

HEATER kW RATING	VOLTAGE DISTRIBUTION	MULTIPLICATION FACTOR
240	200	.69
	208	.75
	230	.92
	240	1.00

Example: 15.0 kW (at 240v) heater on 208v
 = 15.0 (.75 mult factor)
 = 11.25 capacity at 208v

BASE UNIT DIMENSIONS—024—036

UNIT	ELECTRICAL CHARACTERISTICS	UNIT WT.			UNIT HEIGHT			CENTER OF GRAVITY IN [MM]		
		LBS.	KG.	A	X	Y	Z			
PHJ4024	208/230-1-60	253	115	30-1/8 [765]	14 [356]	19 [483]	14 [356]	19 [483]	14 [356]	16 [406]
PHJ4030	208/230-1-60	283	128	34-1/8 [867]	14 [356]	19 [483]	14 [356]	19 [483]	16 [406]	16 [406]
PHJ4036	208/230-1-60	285	130	34-1/8 [867]	14 [356]	19 [483]	14 [356]	19 [483]	16 [406]	16 [406]

REQUIRED CLEARANCES TO COMBUSTIBLE MATL.

	INCHES [MM]
TOP OF UNIT.....	0
BOTTOM OF UNIT.....	0
SIDE OF UNIT OPPOSITE DUCT OPENINGS.....	0
SIDE OF UNIT WITH DUCT OPENINGS.....	0
SIDE OF UNIT OPPOSITE DUCT OPENINGS.....	0

NEC. REQUIRED CLEARANCES.

	INCHES [MM]
BETWEEN UNITS, POWER ENTRY SIDE.....	42.0 [1067]
UNIT AND UNGROUNDED SURFACES, POWER ENTRY SIDE.....	36.0 [914]
UNIT AND BLOCK OR CONCRETE WALLS AND OTHER GROUNDED SURFACES, POWER ENTRY SIDE.....	36.0 [914]
UNIT AND BLOCK OR CONCRETE WALLS AND OTHER GROUNDED SURFACES, POWER ENTRY SIDE.....	42.0 [1067]

REQUIRED CLEARANCE FOR SERVICING

	INCHES [MM]
TOP OF UNIT, OPPOSITE DUCT OPENINGS.....	36.0 [914]
SIDE OF UNIT OPPOSITE DUCT OPENINGS.....	30.0 [762]
SIDE OF UNIT WITH DUCT OPENINGS.....	30.0 [762]
SIDE OF UNIT OPPOSITE DUCT OPENINGS.....	30.0 [762]
(EXCEPT FOR NEC REQUIREMENTS)	

NOTE: CLEARANCES MUST BE MAINTAINED TO PREVENT RECIRCULATION OF AIR FROM OUTDOOR FAN DISCHARGE. A REMOVABLE FENCE OR BARRICADE REQUIRES NO CLEARANCE.

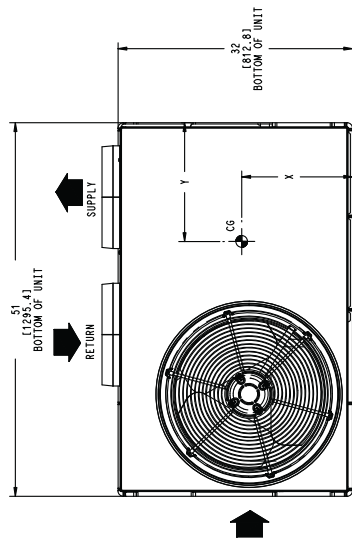

TOP VIEW

DIMENSIONS IN [] ARE IN MM

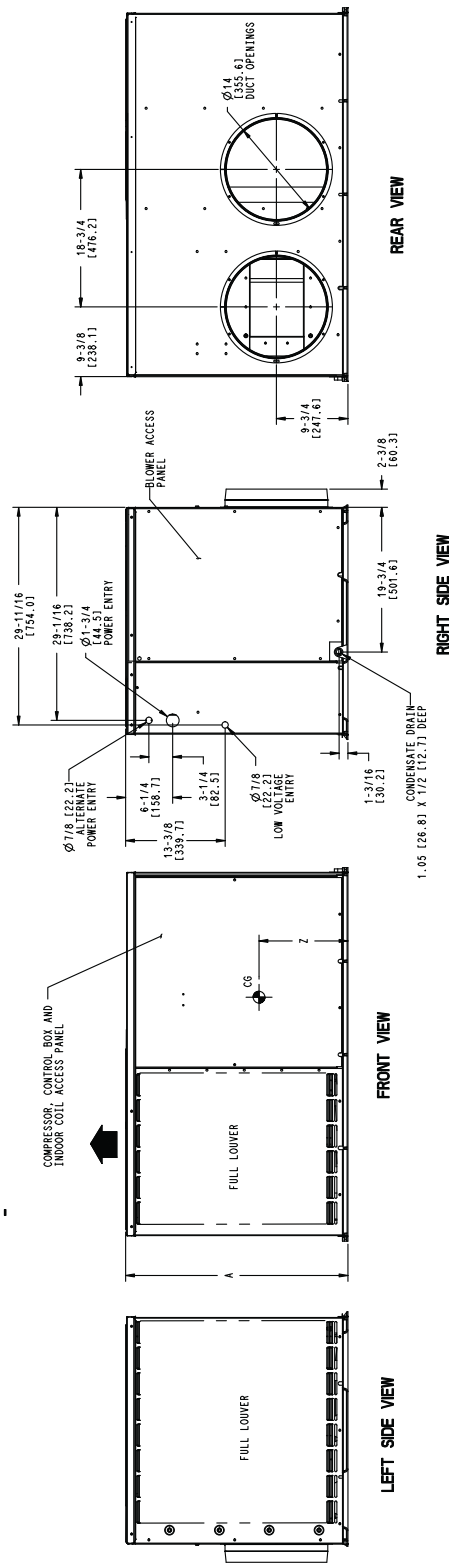

FRONT VIEW

LEFT SIDE VIEW

RIGHT SIDE VIEW

REAR VIEW

BASE UNIT DIMENSIONS—042—048

UNIT	ELECTRICAL CHARACTERISTICS	UNIT WT.		CENTER OF GRAVITY IN (MM)			
		LBS.	KG.	A	X	Y	Z
PHJ042	208/230-1-60	339	154	42-1/8 [1070]	14 [356]	19 [483]	19-3/4 [503]
PHJ048	208/230-1-60	358	163	42-1/8 [1070]	14 [356]	19 [483]	19-3/4 [503]

REQUIRED CLEARANCES TO COMBUSTIBLE MATL.

TOP OF UNIT.....	INCHES (MM)
BOTTOM OF UNIT.....	0
SIDE OF UNIT WITH DUCT OPENINGS.....	0
SIDE OF UNIT OPPOSITE DUCT OPENINGS.....	0

NEC. REQUIRED CLEARANCES.

BETWEEN UNITS, POWER ENTRY SIDE.....	INCHES (MM)
TO AND FROM CONCRETE WALLS AND OTHER.....	42.0 [1067]
UNIT AND BLOCK OF CONCRETE WALLS AND OTHER.....	36.0 [914]
GROUND SURFACES, POWER ENTRY SIDE.....	42.0 [1067]

REQUIRED CLEARANCE FOR SERVICING

TOP OF UNIT.....	INCHES (MM)
SIDE OF UNIT OPPOSITE DUCT OPENINGS.....	36.0 [914]
SIDE OF UNIT WITH POWER ENTRY.....	30.0 [762]
(EXCEPT FOR NEC REQUIREMENTS)	30.0 [762]

NOTE: CLEARANCES MUST BE MAINTAINED TO PREVENT RECIRCULATION OF AIR FROM OUTDOOR FAN DISCHARGE. A REMOVABLE FENCE OR BARRICADE REQUIRES NO CLEARANCE.

DIMENSIONS IN () ARE IN MM

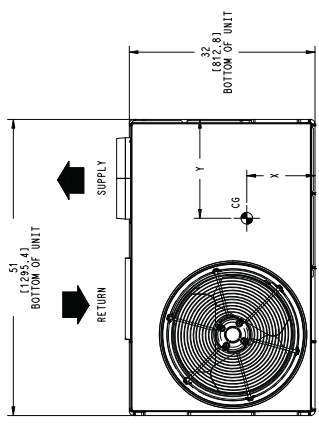

TOP VIEW

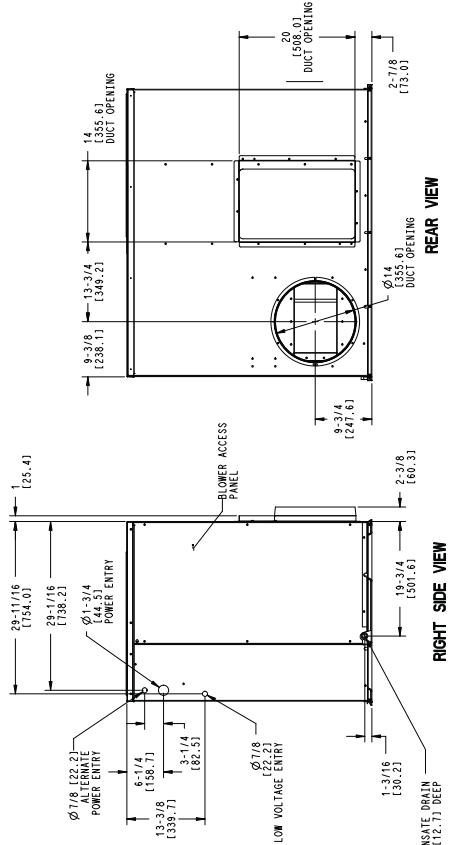

FRONT VIEW

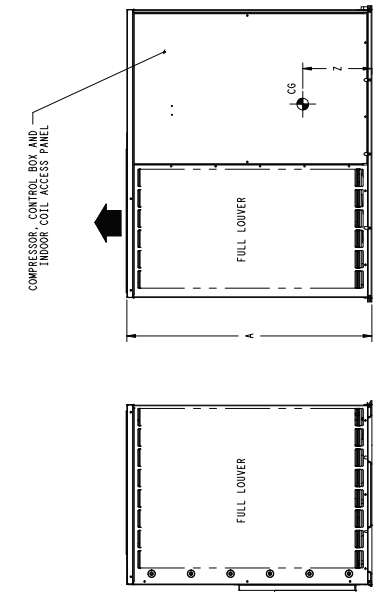

LEFT SIDE VIEW

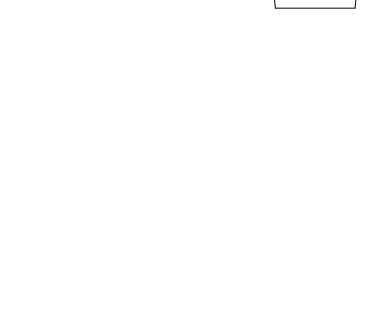

RIGHT SIDE VIEW



REAR VIEW

SELECTION PROCEDURE

I. DETERMINE COOLING AND HEATING REQUIREMENTS AT DESIGN CONDITIONS

Given:

- Required Cooling Capacity (TC) 28,000 Btuh
- Sensible Heat Capacity (SHC) 20,500 Btuh
- Required Heating Capacity 28,550 Btuh
- Outdoor Entering–Air Temperature 95°F (35°C)
- Outdoor–Air Winter Design Temperature 20°F (–6.7°C)
- Indoor–Air Winter Design Temperature 70°F (21.1°C)
- Indoor Entering–Air Temperature 80°F (26.7°C) edb, 67°F ewb (19.4°C)
- Indoor–Air Quantity 1000 CFM
- External Static Pressure 0.20 IN. W.C.
- Electrical Characteristics (V–Ph–Hz) 230–1–60
- edb — entering dry bulb
- ewb — entering wet bulb

II. SELECT UNIT BASED ON REQUIRED COOLING CAPACITY

Enter Cooling Capacities table at condenser entering temperature of 95°F (35°C), indoor air entering at 1000 cfm and 67°F (19.4°C) ewb (entering wet bulb). The 030 unit will provide a total cooling capacity of 28,800 Btuh and a sensible heat capacity of 21,600 Btuh.

For indoor–air temperature other than 80°F edb (entering dry bulb), calculate sensible heat capacity correction, as required, using the formula found in Note 3 following the cooling capacities tables.

NOTE: Unit ratings are net capacities.

III. SELECT ELECTRIC HEAT

Enter the 030 Heating Capacities table at 1000 CFM. At 70°F (21.1°C) return indoor air and 20°F (–6.7°C) air entering outdoor coil, the integrated heating capacity is 16,740 Btuh. (Select integrated heating capacity value since deductions for outdoor–coil frost and defrosting have already been made. No correction is required.)

The required heating capacity is 28,550 Btuh. Therefore, 11,810 Btuh (28,550 – 16,740) additional electric heat is required.

Determine additional electric heat capacity in kW.

$$\frac{11,810 \text{ Btuh}}{3414 \text{ Btuh/kW}} = 3.46 \text{ kW of heat required}$$

Enter the Accessory Electric Heater Usage table on page 4 for 208/240v. single–phase, 030 unit. The 5–kW heater at 240v most closely satisfies the heating required. To calculate kW at 230v, multiply the heater kW by multiplication factor 0.92 found in the Multiplication Factors table on page 4.

$$5 \text{ kW} \times 0.92 = 4.6 \text{ kW}$$

$$4.6 \times 3414 = 15,704 \text{ Btuh}$$

To calculate kW at 208 v, see Multiplication Factors table on page 4.

Total unit heating capacity is 32,444 Btuh (16,740 +15,704).

IV. DETERMINE FAN SPEED AND POWER REQUIREMENTS AT DESIGN CONDITIONS

Before entering the air delivery tables, calculate the total static pressure required. From the given, the Accessory Electric Heat Pressure Drop table, and the Filter Pressure Drop table, find:

External static pressure	0.20 IN. W.C.
Filter	0.09 IN. W.C.
Electric heat	0.04 IN. W.C.
Total static pressure	0.33 IN. W.C.

Enter the table for Dry Coil Air Delivery — Horizontal Discharge at 1000 CFM and 230v high speed. The blower will deliver 1036 CFM @ 0.40 IN W.C. static pressure. This will adequately handle job requirements.

**BUILDING HEAT LOSS, UNIT INTEGRATED HEATING CAPACITY,
MBTUH**

BALANCE POINT WORKSHEET

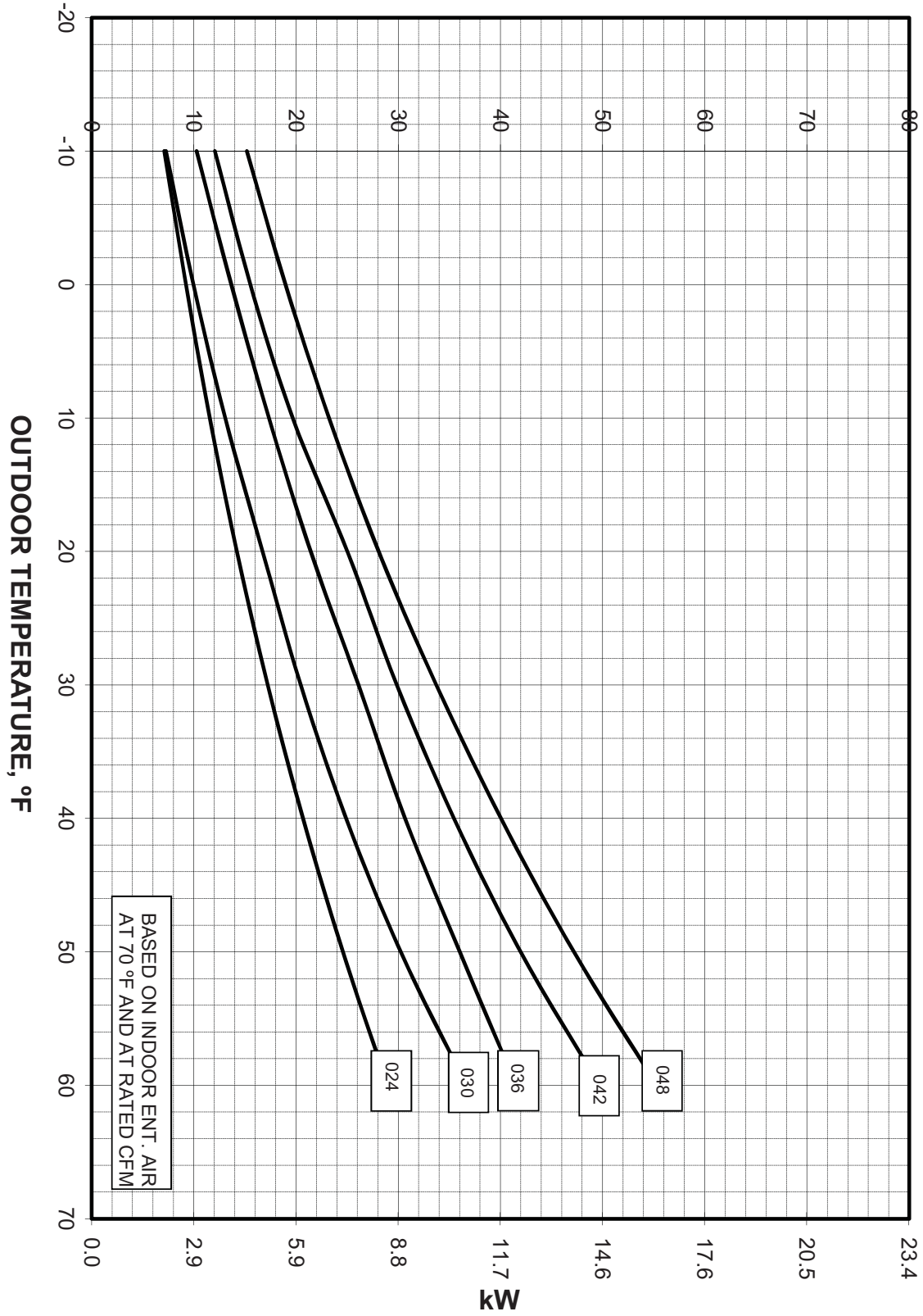

A14654

PERFORMANCE DATA
∞ COOLING CAPACITY

024

EVAPORATOR AIR		CONDENSER ENTERING AIR TEMPERATURES °F (°C)																			
		75 (24)				85 (29)				95 (35)				105 (41)				115 (46)			
		CFM	EWB	Capacity MBtuh		Total Sys kW	Capacity MBtuh		Total Sys kW	Capacity MBtuh		Total Sys kW	Capacity MBtuh		Total Sys kW	Capacity MBtuh		Total Sys kW			
Total	Sens			Total	Sens		Total	Sens		Total	Sens		Total	Sens							
700	57 (14)	24.12	24.12	1.40	22.67	22.67	1.71	21.20	21.20	2.06	19.18	19.18	19.18	19.18	2.47	17.23	17.23	2.96			
	62 (17)	24.97	21.81	1.40	23.28	20.72	1.71	21.59	19.65	2.06	19.26	19.17	19.17	19.17	2.47	17.27	17.27	2.96			
	63* (17)	25.41	17.85	1.40	23.69	16.89	1.71	21.95	15.92	2.07	19.64	14.69	14.69	14.69	2.48	17.12	13.41	2.96			
	67 (19)	27.16	18.34	1.41	25.39	17.41	1.71	23.57	16.44	2.07	21.73	15.52	15.52	15.52	2.50	19.32	14.35	2.99			
	71 (22)	28.96	15.58	1.41	27.15	14.74	1.72	25.27	13.87	2.08	23.32	12.97	12.97	12.97	2.51	21.35	12.14	3.01			
800	57 (14)	25.10	25.10	1.41	23.59	23.59	1.72	22.07	22.07	2.08	20.33	20.33	20.33	20.33	2.50	18.25	18.25	2.99			
	62 (17)	25.54	23.30	1.41	23.84	22.15	1.72	22.15	21.95	2.08	20.37	20.37	20.37	20.37	2.50	18.29	18.29	2.99			
	63* (17)	25.93	18.87	1.41	24.17	17.91	1.72	22.39	16.92	2.08	20.25	15.82	15.82	15.82	2.50	17.61	14.47	2.98			
	67 (19)	27.67	19.35	1.42	25.86	18.42	1.73	24.00	17.45	2.09	22.11	16.50	16.50	16.50	2.51	19.85	15.54	3.00			
	71 (22)	29.43	16.25	1.42	27.61	15.39	1.73	25.68	14.52	2.09	23.69	13.61	13.61	13.61	2.52	21.68	12.78	3.03			
900	57 (14)	25.89	25.89	1.43	24.34	24.34	1.74	22.76	22.76	2.10	21.17	21.17	21.17	21.17	2.52	19.11	19.11	3.02			
	62 (17)	26.05	24.59	1.43	24.36	24.36	1.74	22.78	22.78	2.10	21.19	21.19	21.19	21.19	2.52	19.15	19.15	3.02			
	63* (17)	26.33	19.82	1.43	24.53	18.84	1.74	22.72	17.85	2.10	20.71	16.92	16.92	16.92	2.51	18.05	15.50	3.00			
	67 (19)	28.05	20.28	1.43	26.22	19.35	1.74	24.32	18.35	2.10	22.40	17.40	17.40	17.40	2.53	20.23	16.59	3.03			
	71 (22)	29.80	16.82	1.43	27.95	15.98	1.74	26.00	15.05	2.11	23.97	14.18	14.18	14.18	2.54	21.92	13.33	3.05			

See page 13 for cooling notes.

HEATING CAPACITY

024

INDOOR AIR		OUTDOOR COIL ENTERING AIR TEMPERATURES °F (°C)																															
		-10 (-23)				0 (-18)				10 (-12)				20 (-7)				30 (-1)				40 (4)				50 (10)				60 (16)			
		EDB	CFM	Capacity MBtuh		Total Sys kW	Capacity MBtuh		Total Sys kW	Capacity MBtuh		Total Sys kW	Capacity MBtuh		Total Sys kW	Capacity MBtuh		Total Sys kW	Capacity MBtuh		Total Sys kW	Capacity MBtuh		Total Sys kW	Capacity MBtuh		Total Sys kW						
Total	In-teg			Total	In-teg		Total	In-teg		Total	In-teg		Total	In-teg		Total	In-teg		Total	In-teg		Total	In-teg		Total	In-teg		Total	In-teg	Total	In-teg	Total	In-teg
65 (18)	700	7.26	6.68	1.43	9.31	8.57	1.49	11.6	10.7	1.55	14.3	13.0	1.61	17.3	15.2	1.68	20.8	20.8	1.76	24.7	24.7	1.84	29.1	29.1	1.92								
	800	7.29	6.71	1.42	9.34	8.60	1.48	11.7	10.7	1.53	14.3	13.0	1.59	17.4	15.2	1.65	20.9	20.9	1.71	24.9	24.9	1.79	29.4	29.4	1.86								
	900	7.32	6.74	1.42	9.38	8.63	1.47	11.7	10.7	1.52	14.4	13.0	1.57	17.5	15.3	1.63	21.0	21.0	1.68	25.0	25.0	1.75	29.6	29.6	1.81								
70 (21)	700	7.19	6.61	1.50	9.22	8.48	1.56	11.5	10.5	1.63	14.1	12.8	1.69	17.1	15.0	1.77	20.6	20.6	1.85	24.4	24.4	1.93	28.7	28.7	2.01								
	800	7.21	6.64	1.49	9.24	8.50	1.55	11.5	10.6	1.61	14.2	12.8	1.67	17.2	15.1	1.73	20.6	20.6	1.80	24.6	24.6	1.88	28.9	28.9	1.95								
	900	7.24	6.66	1.49	9.27	8.53	1.54	11.6	10.6	1.60	14.2	12.9	1.65	17.3	15.1	1.71	20.7	20.7	1.77	24.7	24.7	1.84	29.1	29.1	1.90								
75 (24)	700	7.13	6.56	1.58	9.14	8.41	1.64	11.4	10.4	1.71	14.0	12.7	1.78	17.0	14.9	1.86	20.3	20.3	1.94	24.1	24.1	2.03	28.3	28.3	2.11								
	800	7.15	6.58	1.57	9.16	8.43	1.63	11.4	10.5	1.69	14.0	12.7	1.75	17.0	14.9	1.82	20.4	20.4	1.89	24.2	24.2	1.97	28.5	28.5	2.04								
	900	7.18	6.60	1.57	9.18	8.45	1.62	11.4	10.5	1.68	14.1	12.7	1.74	17.1	14.9	1.80	20.5	20.5	1.86	24.4	24.4	1.93	28.7	28.7	1.99								

**PERFORMANCE DATA (CONT)
COOLING CAPACITY**

427 14 1503 00

030

EVAPORATOR AIR		CONDENSER ENTERING AIR TEMPERATURES °F (°C)																			
		75 (24)				85 (29)				95 (35)				105 (41)				115 (46)			
		CFM	EWB	Capacity MBtuh		Total Sys kW	Capacity MBtuh		Total Sys kW	Capacity MBtuh		Total Sys kW	Capacity MBtuh		Total Sys kW	Capacity MBtuh		Total Sys kW			
Total	Sens			Total	Sens		Total	Sens		Total	Sens		Total	Sens							
875	57 (14)		29.19	29.19	1.83	27.65	27.65	2.15	26.07	26.07	2.52	24.44	24.44	2.96	22.71	22.71	3.50				
	62 (17)		30.18	27.57	1.83	28.32	26.44	2.15	26.44	25.29	2.52	24.55	24.09	2.97	22.75	22.75	3.50				
	63* (17)		30.78	22.44	1.84	28.87	21.41	2.16	26.91	20.38	2.53	24.89	19.33	2.97	22.78	18.26	3.50				
	67 (19)		33.32	23.37	1.86	31.28	22.34	2.18	29.18	21.29	2.56	27.03	20.24	3.00	24.77	19.16	3.54				
	71 (22)		36.13	19.96	1.90	33.96	18.99	2.22	31.73	18.02	2.59	29.41	17.02	3.05	27.02	16.01	3.59				
1000	57 (14)		30.53	30.53	1.86	28.89	28.89	2.18	27.22	27.22	2.56	25.48	25.48	3.01	23.65	23.65	3.55				
	62 (17)		31.01	29.67	1.86	29.11	28.44	2.18	27.25	27.25	2.56	25.51	25.51	3.01	23.69	23.69	3.55				
	63* (17)		31.52	23.92	1.87	29.52	22.85	2.19	27.49	21.78	2.56	25.39	20.69	3.00	23.23	19.58	3.54				
	67 (19)		34.09	24.95	1.90	31.97	23.88	2.21	29.80	22.80	2.59	27.56	21.71	3.04	25.24	20.59	3.58				
	71 (22)		36.96	21.08	1.93	34.70	20.08	2.25	32.38	19.07	2.63	29.98	18.05	3.09	27.50	17.01	3.63				
1125	57 (14)		31.66	31.66	1.89	29.94	29.94	2.22	28.18	28.18	2.60	26.36	26.36	3.05	24.44	24.44	3.59				
	62 (17)		31.77	31.56	1.89	29.99	29.99	2.22	28.22	28.22	2.60	26.39	26.39	3.05	24.47	24.47	3.60				
	63* (17)		32.10	25.34	1.90	30.04	24.23	2.22	27.95	23.12	2.59	25.80	22.00	3.04	23.57	20.84	3.57				
	67 (19)		34.70	26.47	1.92	32.51	25.37	2.25	30.28	24.25	2.62	27.98	23.12	3.08	25.60	21.95	3.62				
	71 (22)		37.61	22.15	1.96	35.28	21.13	2.28	32.88	20.09	2.67	30.42	19.04	3.13	27.87	17.97	3.67				

See page 13 for cooling notes.

HEATING CAPACITY

030

INDOOR AIR		OUTDOOR COIL ENTERING AIR TEMPERATURES °F (°C)																															
		-10 (-23)				0 (-18)				10 (-12)				20 (-7)				30 (-1)				40 (4)				50 (10)				60 (16)			
		EDB	CFM	Capacity MBtuh		Total Sys kW	Capacity MBtuh		Total Sys kW	Capacity MBtuh		Total Sys kW	Capacity MBtuh		Total Sys kW	Capacity MBtuh		Total Sys kW	Capacity MBtuh		Total Sys kW	Capacity MBtuh		Total Sys kW	Capacity MBtuh		Total Sys kW						
Total	Integ			Total	Integ		Total	Integ		Total	Integ		Total	Integ		Total	Integ		Total	Integ		Total	Integ		Total	Integ		Total	Integ				
65 (18)	875	7.45	6.85	1.56	10.10	9.29	1.65	13.26	12.17	1.75	16.78	15.22	1.87	20.52	17.98	1.97	24.97	24.97	2.10	30.32	30.32	2.25	36.77	36.77	2.43								
	1000	7.56	6.95	1.57	10.24	9.42	1.65	13.64	12.52	1.75	16.93	15.35	1.85	20.72	18.15	1.95	25.25	25.25	2.07	30.69	30.69	2.21	37.27	37.27	2.38								
	1125	7.66	7.04	1.57	10.36	9.53	1.65	13.77	12.64	1.75	17.07	15.48	1.84	20.89	18.30	1.94	25.48	25.48	2.05	30.99	30.99	2.18	37.62	37.62	2.35								
70 (21)	875	7.17	6.60	1.64	9.82	9.04	1.73	12.89	11.83	1.83	16.59	15.04	1.96	20.25	17.75	2.07	24.63	24.63	2.20	29.87	29.87	2.35	36.20	36.20	2.54								
	1000	7.28	6.70	1.64	9.96	9.16	1.73	13.07	11.99	1.82	16.73	15.17	1.94	20.46	17.92	2.04	24.90	24.90	2.17	30.24	30.24	2.31	36.68	36.68	2.48								
	1125	7.38	6.79	1.65	10.08	9.27	1.73	13.22	12.14	1.82	16.87	15.30	1.93	20.62	18.07	2.03	25.12	25.12	2.15	30.53	30.53	2.28	37.04	37.04	2.45								
75 (24)	875	6.88	6.33	1.71	9.52	8.76	1.81	12.57	11.53	1.91	16.38	14.85	2.05	20.01	17.53	2.17	24.29	24.29	2.30	29.43	29.43	2.46	35.64	35.64	2.65								
	1000	6.99	6.43	1.72	9.66	8.89	1.81	12.74	11.69	1.91	16.54	15.00	2.03	20.20	17.70	2.14	24.55	24.55	2.27	29.78	29.78	2.41	36.11	36.11	2.59								
	1125	7.10	6.53	1.72	9.78	9.00	1.81	12.89	11.83	1.91	16.67	15.12	2.03	20.36	17.84	2.13	24.77	24.77	2.25	30.07	30.07	2.38	36.46	36.46	2.56								

PERFORMANCE DATA (CONT)
COOLING CAPACITY

036

EVAPORATOR AIR		CONDENSER ENTERING AIR TEMPERATURES °F (°C)																		
		75 (24)			85 (29)			95 (35)			105 (41)			115 (46)			125 (52)			
		CFM	EWB	Capacity MBtuh		Total Sys kW	Capacity MBtuh		Total Sys kW	Capacity MBtuh		Total Sys kW	Capacity MBtuh		Total Sys kW	Capacity MBtuh		Total Sys kW		
Total	Sens			Total	Sens		Total	Sens		Total	Sens		Total	Sens						
1050	57 (14)		35.93	35.93	2.36	33.75	33.75	2.70	31.52	31.52	3.08	29.19	29.19	3.52	26.69	26.69	4.03	23.44	23.44	4.55
	62 (17)		37.16	32.72	2.36	34.64	31.84	2.70	32.05	30.86	3.08	29.38	29.75	3.52	26.74	26.74	4.03	23.49	23.49	4.55
	63* (17)		37.80	26.59	2.36	35.24	25.75	2.70	32.57	24.84	3.08	29.78	23.85	3.52	26.72	22.69	4.03	22.54	20.97	4.53
	67 (19)		40.63	27.40	2.36	38.07	26.70	2.70	35.38	25.86	3.09	32.52	24.93	3.54	29.45	23.92	4.05	22.85	22.65	4.64
	72 (22)		43.93	21.95	2.37	41.38	21.32	2.72	38.64	20.59	3.12	35.74	19.79	3.57	32.68	18.87	4.08	29.43	17.90	4.66
	57 (14)		37.48	37.48	2.39	35.25	35.25	2.73	32.94	32.94	3.12	30.53	30.53	3.56	27.93	27.93	4.08	24.77	24.77	4.64
1200	62 (17)		38.06	35.03	2.39	35.55	34.11	2.73	33.04	32.82	3.12	30.58	30.58	3.56	27.97	27.97	4.08	24.83	24.83	4.64
	63* (17)		38.56	28.13	2.39	35.95	27.33	2.73	33.26	26.45	3.12	30.41	25.47	3.56	27.26	24.30	4.08	23.13	22.62	4.58
	67 (19)		41.32	28.90	2.39	38.73	28.26	2.74	36.00	27.47	3.13	33.12	26.57	3.58	30.03	25.59	4.09	26.44	24.43	4.67
	72 (22)		44.53	22.75	2.41	41.96	22.17	2.76	39.19	21.46	3.16	36.22	20.68	3.61	33.12	19.74	4.12	29.83	18.82	4.70
	57 (14)		38.67	38.67	2.42	36.40	36.40	2.76	34.04	34.04	3.15	31.58	31.58	3.60	28.94	28.94	4.12	25.94	25.94	4.71
	62 (17)		38.83	36.99	2.42	36.44	36.44	2.76	34.09	34.09	3.15	31.62	31.62	3.60	28.98	28.98	4.12	25.98	25.98	4.71
1350	63* (17)		39.12	29.53	2.42	36.50	28.79	2.77	33.77	27.94	3.16	30.89	26.97	3.60	27.73	25.85	4.11	23.68	24.16	4.64
	67 (19)		41.83	30.27	2.43	39.21	29.67	2.77	36.45	28.95	3.17	33.55	28.08	3.62	30.48	27.11	4.13	26.96	26.05	4.71
	72 (22)		44.95	23.44	2.44	42.38	22.92	2.80	39.58	22.24	3.20	36.58	21.46	3.65	33.42	20.55	4.16	30.10	19.65	4.75

See page 13 for cooling notes.

HEATING CAPACITY
036

INDOOR AIR		OUTDOOR COIL ENTERING AIR TEMPERATURES °F (°C)																							
		-10 (-23)			0 (-18)			10 (-12)			20 (-7)			30 (-1)			40 (4)			50 (10)			60 (16)		
		EDB	CFM	Capacity MBtuh		Total Sys kW	Capacity MBtuh		Total Sys kW	Capacity MBtuh		Total Sys kW	Capacity MBtuh		Total Sys kW	Capacity MBtuh		Total Sys kW	Capacity MBtuh		Total Sys kW	Capacity MBtuh		Total Sys kW	
Total	Integ			Total	Integ		Total	Integ		Total	Integ		Total	Integ		Total	Integ		Total	Integ		Total	Integ		
65 (16)	1050	10.63	9.78	2.08	13.98	12.86	2.18	17.60	16.15	2.29	21.69	19.67	2.41	26.19	22.94	2.56	30.74	30.74	2.70	36.06	36.06	2.85	41.91	41.91	3.00
	1200	10.83	9.96	2.09	14.19	13.05	2.19	17.87	16.40	2.30	22.40	20.31	2.42	26.47	23.19	2.54	31.10	31.10	2.66	36.49	36.49	2.79	42.00	42.00	2.93
	1350	11.01	10.13	2.11	14.39	13.24	2.21	18.09	16.61	2.31	22.61	20.51	2.42	26.70	23.40	2.53	31.39	31.39	2.65	36.68	36.68	2.76	41.92	41.92	2.89
70 (21)	1050	10.08	9.27	2.15	13.46	12.38	2.26	17.08	15.67	2.38	21.12	19.15	2.51	25.84	22.64	2.67	30.33	30.33	2.82	35.56	35.56	2.99	41.41	41.41	3.14
	1200	10.27	9.45	2.17	13.66	12.57	2.27	17.36	15.94	2.38	21.43	19.44	2.50	26.11	22.88	2.65	30.67	30.67	2.78	36.02	36.02	2.92	41.55	41.55	3.07
	1350	10.45	9.61	2.19	13.86	12.75	2.29	17.59	16.14	2.39	21.70	19.68	2.50	26.35	23.09	2.64	30.96	30.96	2.77	36.27	36.27	2.89	41.52	41.52	3.02
75 (24)	1050	9.51	8.75	2.24	12.91	11.88	2.35	16.55	15.19	2.48	20.59	18.68	2.61	25.51	22.35	2.79	29.92	29.92	2.95	35.06	35.06	3.13	40.90	40.90	3.29
	1200	9.70	8.92	2.26	13.14	12.09	2.37	16.82	15.44	2.48	20.89	18.95	2.60	25.78	22.59	2.76	30.26	30.26	2.91	35.52	35.52	3.06	41.07	41.07	3.21
	1350	9.86	9.07	2.28	13.33	12.27	2.38	17.04	15.64	2.49	21.15	19.18	2.61	26.00	22.78	2.75	30.54	30.54	2.89	35.82	35.82	3.02	41.08	41.08	3.16

**PERFORMANCE DATA (CONT)
COOLING CAPACITY**

427 14 1503 00

042

EVAPORATOR AIR		CONDENSER ENTERING AIR TEMPERATURES °F (°C)																	
		75 (24)			85 (29)			95 (35)			105 (41)			115 (46)			125 (52)		
		CFM	EWB	Capacity MB-tuh		Total Sys kW	Capacity MB-tuh		Total Sys kW	Capacity MB-tuh		Total Sys kW	Capacity MB-tuh		Total Sys kW	Capacity MB-tuh		Total Sys kW	
Total	Sens			Total	Sens		Total	Sens		Total	Sens		Total	Sens					
1225	57 (14)		42.14	2.64	39.63	39.63	3.08	37.01	37.01	3.57	33.27	33.27	4.08	29.84	29.84	4.70	26.47	26.47	5.43
	62 (17)		43.42	2.64	40.45	35.78	3.09	37.42	34.53	3.57	33.34	33.34	4.09	29.89	29.89	4.70	26.52	26.52	5.43
	63* (17)		44.22	2.65	41.17	28.91	3.09	38.00	27.77	3.58	33.40	26.01	4.08	29.10	24.34	4.69	24.87	22.66	5.40
1400	67 (19)		47.88	3.12	44.54	30.15	3.11	41.19	29.02	3.61	37.71	27.83	4.17	32.76	26.04	4.76	28.12	24.34	5.46
	72 (22)		53.01	2.69	49.32	24.38	3.15	45.63	23.29	3.64	41.90	22.17	4.21	38.07	21.00	4.86	33.06	19.39	5.57
	57 (14)		44.02	2.68	41.35	41.35	3.13	38.61	38.61	3.62	35.22	35.22	4.16	31.40	31.40	4.77	27.77	27.77	5.50
1575	62 (17)		44.58	2.69	41.57	38.42	3.13	38.66	38.66	3.62	35.31	35.31	4.16	31.46	31.46	4.78	27.82	27.82	5.50
	63* (17)		45.24	2.69	42.05	30.87	3.13	38.79	29.71	3.62	34.39	28.04	4.14	29.80	26.25	4.74	25.51	24.46	5.45
	67 (19)		48.95	3.40	45.46	32.26	3.16	42.00	31.10	3.65	38.44	29.89	4.22	33.67	28.17	4.82	28.82	26.35	5.52
1725	72 (22)		54.17	2.73	50.34	25.70	3.19	46.51	24.59	3.69	42.63	23.44	4.25	38.72	22.26	4.91	34.00	20.78	5.64
	57 (14)		45.62	2.73	42.79	42.79	3.18	39.93	39.93	3.67	36.90	36.90	4.24	32.77	32.77	4.84	28.92	28.92	5.57
	62 (17)		45.69	2.73	42.85	42.85	3.18	39.99	39.99	3.67	36.95	36.95	4.24	32.83	32.83	4.84	28.97	28.97	5.57
1575	63* (17)		46.05	2.73	42.74	32.75	3.18	39.39	31.55	3.67	35.82	30.22	4.22	30.44	28.04	4.80	26.11	26.11	5.51
	67 (19)		49.78	3.47	46.20	34.29	3.20	42.60	33.09	3.70	38.98	31.84	4.26	34.50	30.21	4.88	29.45	28.21	5.58
	72 (22)		55.07	2.78	51.13	26.97	3.23	47.18	25.83	3.73	43.21	24.67	4.30	39.18	23.46	4.96	34.88	22.14	5.72

See page 13 for cooling notes.

HEATING CAPACITY

042

INDOOR AIR		OUTDOOR COIL ENTERING AIR TEMPERATURES °F (°C)																								
		-10 (-23)			0 (-18)			10 (-12)			20 (-7)			30 (-1)			40 (4)			50 (10)			60 (16)			
		EDB	CFM	Capacity MBtuh		Total Sys kW	Capacity MBtuh		Total Sys kW	Capacity MBtuh		Total Sys kW	Capacity MBtuh		Total Sys kW	Capacity MBtuh		Total Sys kW	Capacity MBtuh		Total Sys kW					
Total	Integ			Total	Integ		Total	Integ		Total	Integ		Total	Integ		Total	Integ		Total	Integ						
65 (16)	1225		12.34	11.36	2.53	15.76	14.50	2.57	19.85	18.22	2.65	25.09	22.75	2.79	29.92	26.22	2.93	35.54	35.54	3.11	42.06	42.06	3.32	49.79	49.79	3.56
	1400		12.54	11.54	2.55	15.97	14.70	2.58	20.10	18.45	2.65	25.31	22.95	2.78	30.19	26.45	2.91	35.91	35.91	3.07	42.55	42.55	3.27	50.45	50.45	3.50
	1575		12.71	11.69	2.57	16.16	14.87	2.59	20.31	18.64	2.65	25.49	23.12	2.78	30.42	26.65	2.89	36.21	36.21	3.04	42.96	42.96	3.23	50.96	50.96	3.46
70 (21)	1225		11.85	10.90	2.61	15.29	14.07	2.66	19.40	17.80	2.75	24.42	22.15	2.89	29.57	25.91	3.07	35.07	35.07	3.25	41.48	41.48	3.46	49.05	49.05	3.71
	1400		12.06	11.09	2.63	15.53	14.29	2.67	19.67	18.05	2.75	25.02	22.69	2.90	29.86	26.16	3.04	35.46	35.46	3.21	41.97	41.97	3.41	49.70	49.70	3.64
	1575		12.24	11.26	2.65	15.73	14.47	2.69	19.88	18.25	2.76	25.23	22.88	2.90	30.11	26.38	3.03	35.77	35.77	3.19	42.37	42.37	3.38	50.21	50.21	3.60
75 (24)	1225		11.26	10.36	2.68	14.75	13.57	2.75	18.88	17.33	2.86	23.67	21.47	3.00	29.23	25.61	3.20	34.61	34.61	3.39	40.89	40.89	3.61	48.32	48.32	3.87
	1400		11.48	10.56	2.70	14.99	13.80	2.76	19.15	17.58	2.86	24.06	21.82	2.99	29.52	25.86	3.18	34.98	34.98	3.35	41.38	41.38	3.56	48.96	48.96	3.80
	1575		11.67	10.74	2.73	15.21	13.99	2.78	19.39	17.80	2.87	24.38	22.11	2.99	29.75	26.06	3.16	35.30	35.30	3.33	41.78	41.78	3.52	49.46	49.46	3.76

PERFORMANCE DATA (CONT)
COOLING CAPACITY

048

EVAPORATOR AIR		CONDENSER ENTERING AIR TEMPERATURES °F (°C)																							
		75 (24)				85 (29)				95 (35)				105 (41)				115 (46)				125 (52)			
		CFM	EWB	Capacity MBtuh		Total Sys kW	Capacity MBtuh		Total Sys kW	Capacity MBtuh		Total Sys kW	Capacity MBtuh		Total Sys kW	Capacity MBtuh		Total Sys kW	Capacity MBtuh		Total Sys kW				
Total	Sens			Total	Sens		Total	Sens		Total	Sens		Total	Sens		Total	Sens								
1400	57 (14)		46.42	46.42	3.18	44.08	44.08	3.54	41.54	41.54	3.95	38.75	38.75	4.42	35.66	35.66	4.95	32.25	32.25	5.57					
	62 (17)		47.91	40.50	3.18	45.08	39.17	3.55	42.09	37.68	3.96	38.91	38.54	4.42	35.70	35.70	4.95	32.29	32.29	5.57					
	63* (17)		48.68	33.02	3.18	45.78	31.78	3.55	42.67	30.46	3.96	39.29	29.02	4.42	35.60	35.60	4.95	31.60	25.78	5.57					
	67 (19)		52.27	34.25	3.20	49.14	32.98	3.58	45.78	31.63	3.99	42.12	30.16	4.45	38.13	38.13	4.98	33.83	26.88	5.59					
1600	72 (22)		57.10	27.89	3.22	53.65	26.66	3.61	49.95	25.33	4.02	45.93	23.91	4.49	41.59	41.59	5.01	36.91	20.74	5.61					
	57 (14)		48.26	48.26	3.23	45.74	45.74	3.60	43.02	43.02	4.01	40.04	40.04	4.48	36.76	36.76	5.02	33.12	33.12	5.63					
	62 (17)		49.02	43.31	3.23	46.11	41.79	3.61	43.09	43.09	4.01	40.09	40.09	4.48	36.80	36.80	5.02	33.15	33.15	5.63					
	63* (17)		49.67	35.05	3.24	46.64	33.77	3.61	43.39	32.40	4.02	39.87	30.91	4.48	36.05	36.05	5.01	31.96	27.51	5.62					
1800	67 (19)		53.29	36.42	3.25	50.03	35.11	3.63	46.50	33.70	4.04	42.68	32.18	4.50	38.56	38.56	5.03	34.15	28.73	5.64					
	72 (22)		58.19	29.22	3.27	54.58	27.94	3.66	50.71	26.58	4.08	46.53	25.11	4.54	42.02	42.02	5.07	37.21	21.88	5.66					
	57 (14)		49.79	49.79	3.28	47.12	47.12	3.66	44.25	44.25	4.07	41.10	41.10	4.54	37.62	37.62	5.07	33.80	33.80	5.68					
	62 (17)		50.03	49.53	3.28	47.17	47.17	3.66	44.30	44.30	4.07	41.15	41.15	4.54	37.65	37.65	5.07	33.83	33.83	5.69					
1800	63* (17)		50.44	37.00	3.29	47.28	35.67	3.66	43.93	34.25	4.07	40.31	32.70	4.53	36.41	36.41	5.06	32.23	29.06	5.67					
	67 (19)		54.07	38.50	3.30	50.68	37.14	3.68	47.02	35.68	4.10	43.10	34.10	4.56	38.87	38.87	5.08	34.38	30.42	5.69					
1800	72 (22)		59.02	30.47	3.32	55.27	29.16	3.71	51.27	27.76	4.13	46.95	26.26	4.59	42.32	42.32	5.12	37.39	22.97	5.71					

See page 13 for cooling notes.

HEATING CAPACITY
048

INDOOR AIR		OUTDOOR COIL ENTERING AIR TEMPERATURES °F (°C)																															
		-10 (-23)				0 (-18)				10 (-12)				20 (-7)				30 (-1)				40 (4)				50 (10)				60 (16)			
		EDB	CFM	Capacity MBtuh		Total Sys kW	Capacity MBtuh		Total Sys kW	Capacity MBtuh		Total Sys kW	Capacity MBtuh		Total Sys kW	Capacity MBtuh		Total Sys kW	Capacity MBtuh		Total Sys kW	Capacity MBtuh		Total Sys kW	Capacity MBtuh		Total Sys kW						
Total	Integ			Total	Integ		Total	Integ		Total	Integ		Total	Integ		Total	Integ		Total	Integ		Total	Integ		Total	Integ							
65 (18)	1400	15.18	13.97	2.94	19.00	17.48	3.05	23.31	21.40	3.17	28.19	25.57	3.30	33.88	29.68	3.43	40.24	40.24	3.57	47.39	47.39	3.71	55.53	55.53	3.84								
	1600	15.30	14.07	2.96	19.11	17.58	3.07	23.43	21.50	3.17	28.32	25.68	3.29	34.03	29.82	3.41	40.45	40.45	3.53	47.70	47.70	3.65	55.99	55.99	3.76								
	1800	15.41	14.18	2.99	19.23	17.69	3.09	23.55	21.62	3.19	28.46	25.81	3.29	34.20	29.96	3.40	40.66	40.66	3.51	47.98	47.98	3.62	56.39	56.39	3.71								
70 (21)	1400	15.09	13.89	3.06	18.87	17.37	3.18	23.15	21.25	3.31	27.98	25.37	3.44	33.59	29.43	3.58	39.86	39.86	3.72	46.87	46.87	3.86	54.85	54.85	4.01								
	1600	15.19	13.97	3.08	18.96	17.45	3.19	23.24	21.33	3.31	28.08	25.47	3.42	33.73	29.55	3.55	40.06	40.06	3.68	47.18	47.18	3.80	55.31	55.31	3.93								
75 (24)	1800	15.29	14.07	3.11	19.07	17.54	3.21	23.35	21.43	3.32	28.20	25.58	3.43	33.87	29.68	3.54	40.25	40.25	3.66	47.45	47.45	3.77	55.70	55.70	3.87								
	1400	15.08	13.88	3.20	18.82	17.32	3.32	23.04	21.15	3.45	27.80	25.21	3.59	33.33	29.20	3.74	39.48	39.48	3.89	46.35	46.35	4.03	54.16	54.16	4.18								
	1600	15.16	13.95	3.22	18.89	17.38	3.33	23.12	21.22	3.45	27.89	25.30	3.57	33.45	29.31	3.70	39.67	39.67	3.84	46.65	46.65	3.97	54.61	54.61	4.09								
1800	15.25	14.03	3.24	18.98	17.46	3.35	23.21	21.30	3.46	28.00	25.39	3.57	33.58	29.42	3.69	39.85	39.85	3.82	46.91	46.91	3.93	55.01	55.01	4.04									

PERFORMANCE DATA (CONT)

427 14 1503 00

LEGEND

- BF— Bypass Factor
db — Dry Bulb
edb— Entering Dry—Bulb
Ewb — Entering Wet—Bulb
kW — Total Unit Power Input
ldb— Leaving Dry—Bulb
lwb— Leaving Wet—Bulb
SHC — Sensible Heat Capacity (1000 Btuh)
TC — Total Capacity (1000 Btuh) (net)
- *At 75 °F (23.9°C) entering dry bulb (Tennessee Valley Authority [TVA] rating conditions); all other at 80 °F (26.75 °C) entering dry bulb.

COOLING NOTES:

1. Ratings are net; they account for the effects of the evaporator—fan motor power and heat.
2. Direct interpolation is permissible. Do not extrapolate.
3. The following formulas may be used:

$$t_{ldb} = t_{edb} - \frac{\text{Sensible capacity (Btuh)}}{1.10 \times \text{CFM}}$$

$$t_{lwb} = \frac{\text{Wet-bulb temperature corresponding to enthalpy}}{\text{air leaving evaporator coil } (h_{lwb})} \quad h_{lwb} = \frac{\text{total capacity (Btuh)}}{4.5 \times \text{CFM}}$$

Where: h_{lwb} = Enthalpy of air entering evaporator coil

4. The SHC is based on 80 °F (26.7 °C) edb temperature of air entering evaporator coil. Below 80 °F (26.7 °C) edb, subtract (corr factor x CFM) from SHC. Above 80 °F (26.7 °C) edb, add (corr factor x CFM) to SHC.
Correction Factor = $1.10 \times (1 - \text{BF}) \times (\text{edb} - 80)$.

PERFORMANCE DATA (CONT)

Filter Pressure Drop (IN. W.C.)

FILTER SIZE in. (mm)	CFM																	
	500	600	700	800	900	1000	1100	1200	1300	1400	1500	1600	1700	1800	1900	2000	2100	2200
20X20X1 (508X508X25)	0.05	0.07	0.08	0.10	0.12	0.13	0.14	0.15	—	—	—	—	—	—	—	—	—	—
20X24X1 (508X610X25)	—	—	—	0.08	0.09	0.10	0.11	0.13	0.14	0.15	0.16	—	—	—	—	—	—	—
24X30X1 (610X762X25)	—	—	—	0.04	0.05	0.06	0.07	0.07	0.08	0.09	0.10	—	—	—	—	—	—	—
24X36X1 (610X914X25)	—	—	—	—	—	—	—	0.06	0.07	0.07	0.08	0.09	0.09	0.10	0.11	0.12	0.13	0.14

Accessory Electric Heat Pressure Drop (IN. W.C.)

HEATER kW	CFM							
	800	1000	1200	1400	1600	1800	2000	2200
5-20	0.033	0.037	0.042	0.047	0.052	0.060	0.067	0.075

Wet Coil Air Delivery* (Deduct 10 percent for 208 Volt Operation)

230 VOLT HORIZONTAL DISCHARGE												
UNIT SIZE	SPEED TAP	AIR DELIVERY ²	EXTERNAL STATIC PRESSURE (IN. W.C.)									
			0.1	0.2	0.3	0.4	0.5	0.6	0.7	0.8	0.9	1.0
024	1	SCFM	933	799	758	707	675	608	549	497	435	394
	2	SCFM	1016	921	882	854	809	761	711	668	599	552
	3	SCFM	1079	1041	1003	970	944	909	866	810	764	724
030	1	SCFM	1052	1018	984	943	914	879	833	795	732	678
	2	SCFM	1141	1107	1069	1036	1006	974	932	899	856	784
	3	SCFM	1246	1213	1181	1144	1108	1078	1043	1015	973	931
036	1	SCFM	1311	1253	1195	1136	1083	1023	958	895	818	729
	2	SCFM	1413	1364	1313	1256	1203	1148	1084	1022	969	882
	3	SCFM	1571	1525	1473	1423	1364	1313	1261	1210	1156	1090
042	1	SCFM	1499	1434	1394	1349	1307	1273	1232	1169	1108	1038
	2	SCFM	1568	1532	1497	1459	1407	1381	1346	1304	1252	1185
	3	SCFM	1635	1593	1560	1523	1484	1439	1406	1369	1335	1264
048	1	SCFM	1657	1625	1590	1554	1517	1486	1448	1417	1381	1340
	2	SCFM	1707	1673	1644	1614	1586	1549	1515	1479	1449	1407
	3	SCFM	1931	1900	1870	1840	1809	1778	1749	1714	1683	1646

*Air delivery values are based on operating voltage of 230v, wet coil, without filter or electric heater. Deduct filter and electric heater pressure drops to obtain static pressure available for ducting.

NOTES:

1. Do not operate the unit at a cooling airflow that is less than 350 cfm for each 12,000 Btuh of rated cooling capacity. Evaporator coil frosting may occur at airflows below this point.
2. Standard Cubic Feet per Minute

ELECTRICAL DATA

Units	Nominal V-PH-HZ	Voltage Range		Compressor		OFM FLA	IFM FLA	Electrical Heat			Power Supply		
		MIN	MAX	RLA	LRA			Nominal kW*	FLA		MCA		MOCP**
									208	240	208	230	
24	208/230-1-60	197	253	10.3	61.6	0.9	2.8	-/-	-	-	16.6	16.6	25
								3.8/5	18	20.8	39.1	42.6	40/45
								5.6/7.2	27	31.3	50.3	55.7	60/60
								7.5/10	36.1	41.7	61.7	68.7	70/70
30	208/230-1-60	197	253	13.5	72.5	0.9	2.8	-/-	-	-	20.6	20.6	30
								3.8/5	18	20.8	43.1	46.6	45/50
								5.6/7.2	27	31.3	54.3	59.7	60/60
								7.5/10	36.1	41.7	65.7	72.7	70/80
36	208/230-1-60	197	253	14.7	75.0	1.7	4.1	-/-	-	-	24.2	24.2	35
								3.8/5	18	20.8	46.7	50.2	50/60
								5.6/7.2	27	31.3	57.9	63.3	60/70
								7.5/10	36.1	41.7	69.3	76.3	70/80
42	208/230-1-60	197	253	16.3	112.3	1.7	4.1	11.3/15	54.1	62.5	91.8	102.3	100/110
								-/-	-	-	26.1	26.1	40
								3.8/5	18	20.8	48.7	52.5	50/60
								5.6/7.2	27	31.3	59.9	65.3	60/70
48	208/230-1-60	197	253	18.3	108.0	1.7	6.0	7.5/10	36.1	41.7	71.3	78.3	80/80
								11.3/15	54.1	62.5	93.8	104.3	100/110
								-/-	-	-	30.6	30.6	45
								3.8/5	18	20.8	53.1	56.6	60/60
								5.6/7.2	27	31.3	64.3	69.7	70/70
								7.5/10	36.1	41.7	75.7	82.7	80/90
								11.3/15	54.1	62.5	98.2	108.7	100/110
								15.0/20.0	72.1	83.3	120.7	134	125/150

*kW @ 208/240

** HACR Type Circuit Breaker

LEGEND

FLA – Full Load Amps

LRA – Locked Rotor Amps

MCA – Minimum Circuit Amps

MOCP – Maximum Overcurrent Protection

RLA – Rated Load Amps

NOTES:

1. In compliance with NEC (National Electrical Code) requirements for multimotor and combination load equipment (refer to NEC Articles 430 and 440), the overcurrent protective device for the unit shall be Power Supply fuse or circuit breaker.

2. Minimum wire size is based on 60°C copper wire. If other than 60°C wire is used, or if length exceeds wire length in table, determine size from NEC.

*Heater capacity (kW) based on heater voltage of 208v & 240v. If power distribution voltage to unit varies from rated heater voltage, heater kW will vary accordingly.

TYPICAL INSTALLATION

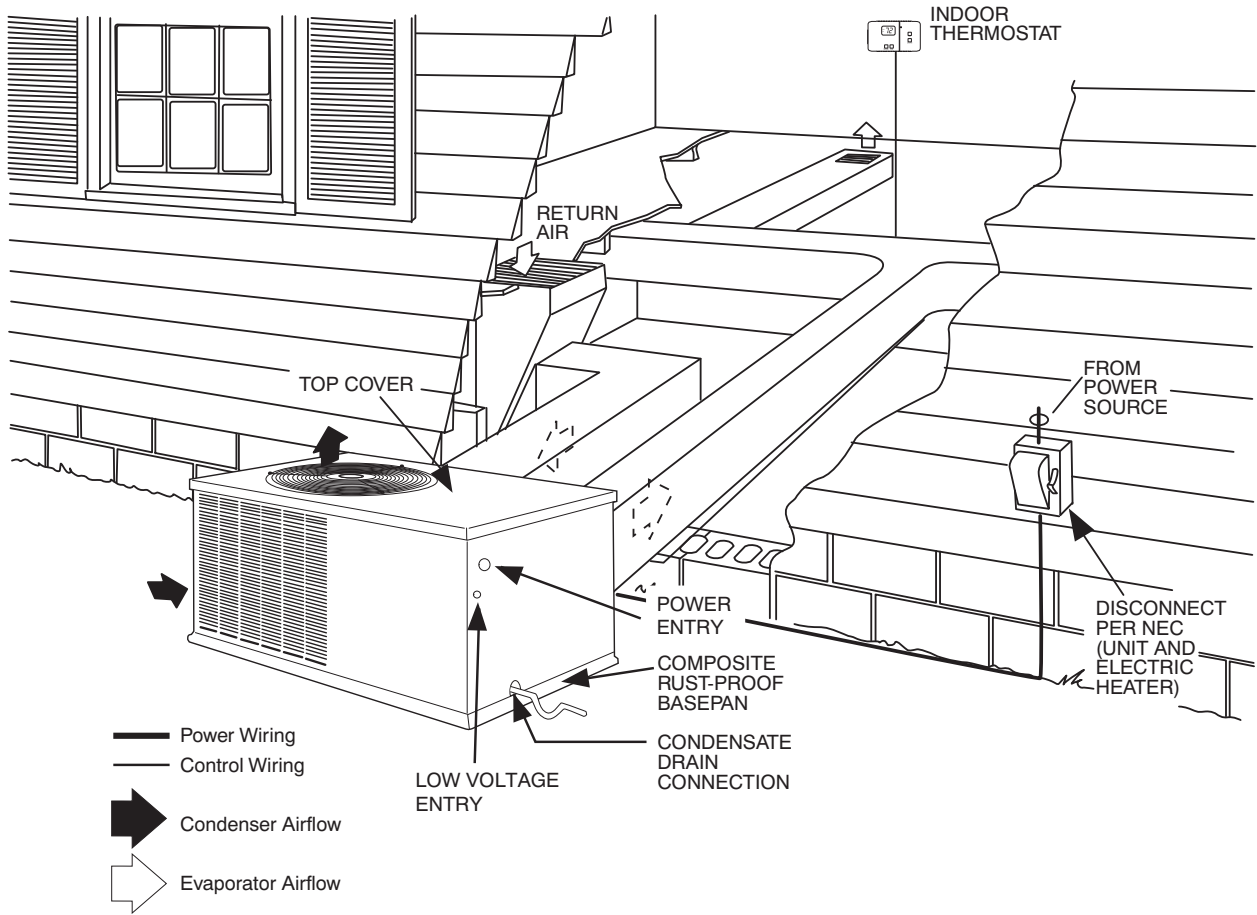

A10135

TYPICAL CONNECTION WIRING SCHEMATIC—208/230-1-60

CONNECTION WIRING DIAGRAM

DANGER: ELECTRICAL SHOCK HAZARD DISCONNECT POWER BEFORE SERVICING

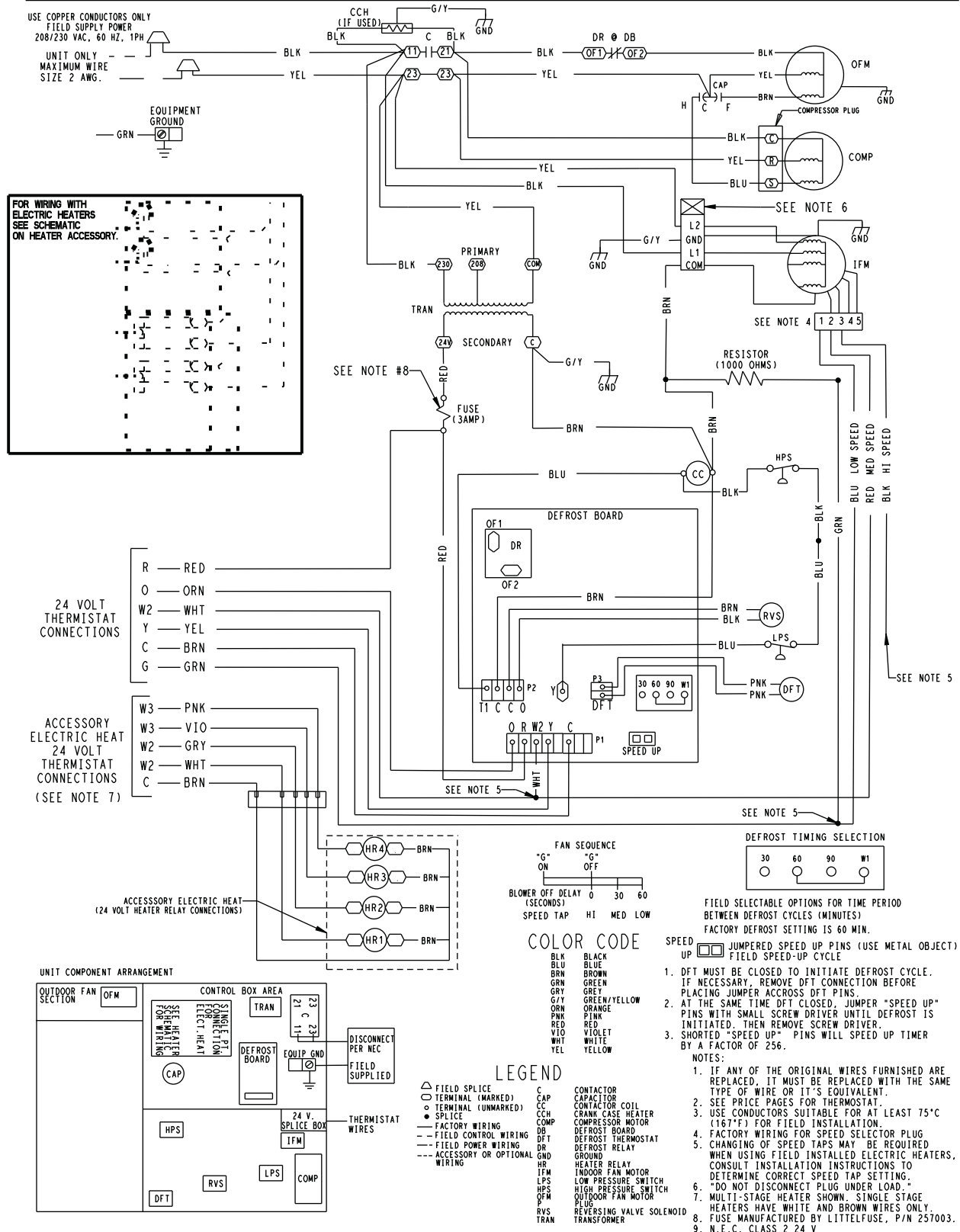

TYPICAL LADDER WIRING SCHEMATIC—208/230-1-60

LADDER WIRING DIAGRAM

DANGER: ELECTRICAL SHOCK HAZARD DISCONNECT POWER BEFORE SERVICING

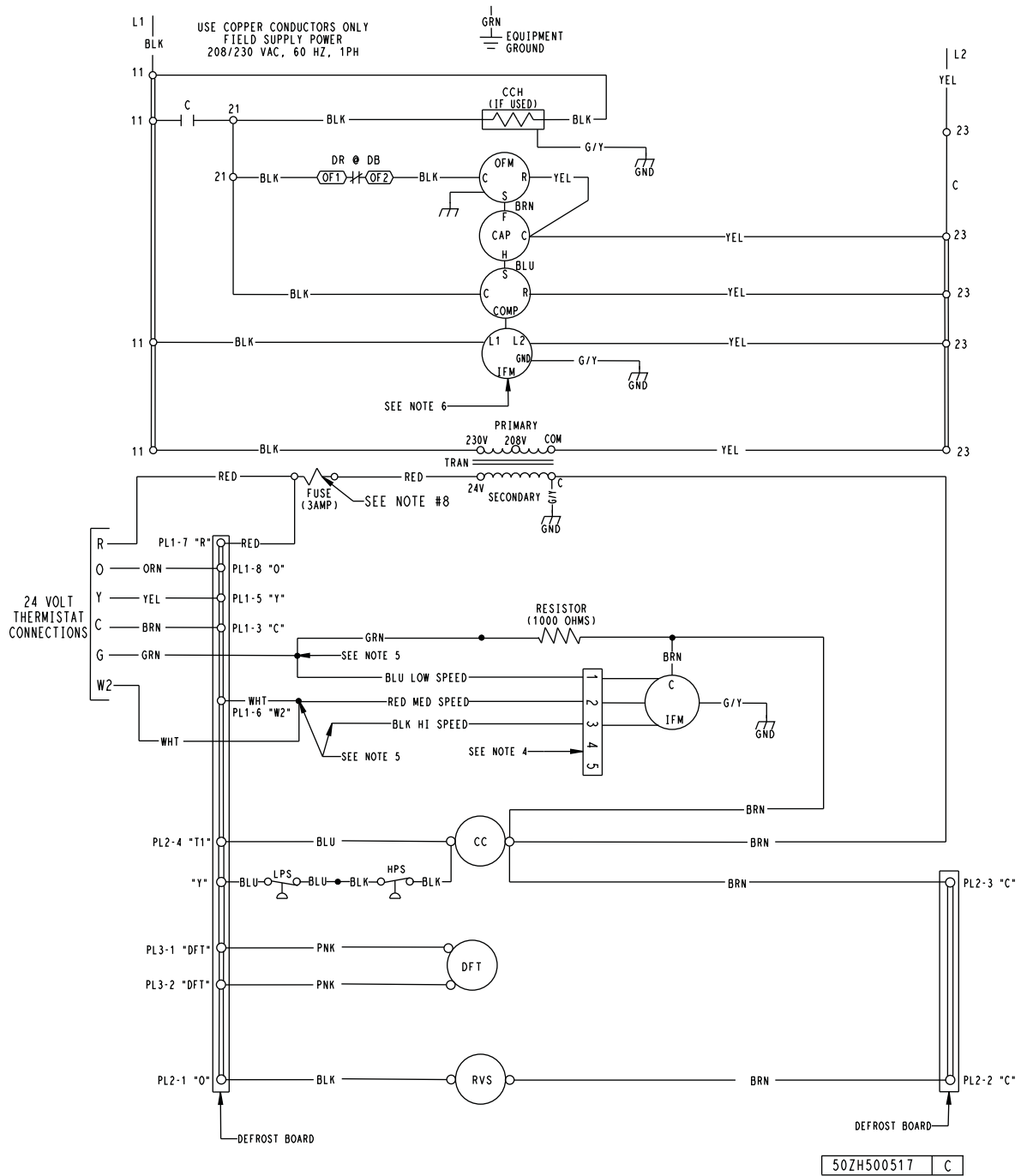

A14564

TYPICAL WIRING SCHEMATIC (CONT)

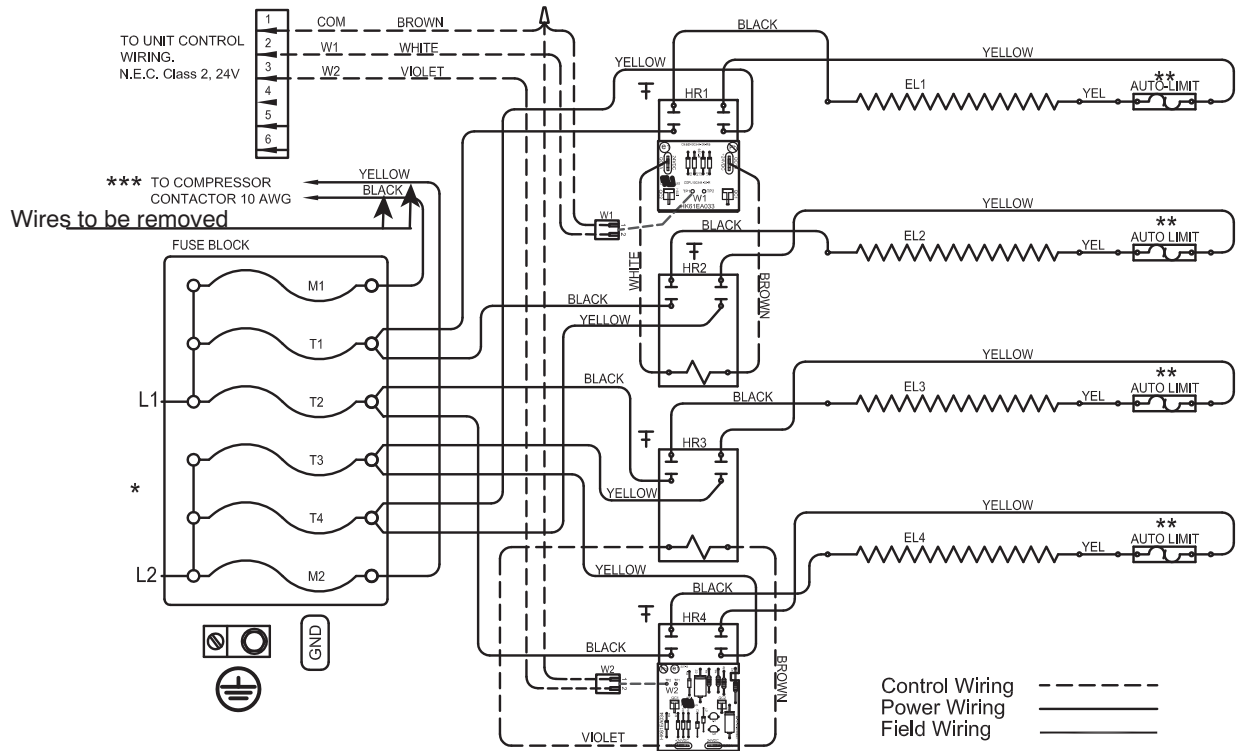

Accessory Electric Heater Wiring

A14444

CONTROLS

Sequence of operation

When power is supplied to unit, the transformer (TRAN) is energized.

Cooling Operation — With a call for cooling (O,Y,G), the reversing valve, contactor, and indoor fan are energized. When the cooling demand is met, Y and G are de-energized, shutting off the contactor (compressor, outdoor fan). The indoor fan stops after a 60 second delay.

Heating Operation — With a call for heating (Y,G), the contactor and indoor fan are energized. When the heating demand is met, Y and G are de-energized, shutting off the contactor (compressor, outdoor fan). The indoor fan stops after a 60 second delay.

Continuous Fan — With the continuous indoor fan option selected on the thermostat, G is continuously energized keeping the indoor fan running at all times.

Defrost — The defrost control is a time/temperature control which includes a field-selectable time period between defrost cycles of 30, 60, and 90 minutes. Electronic timer and defrost cycle start only when contactor is energized and defrost thermostat (DFT) is closed.

Defrost mode is identical to cooling mode, except outdoor fan motor stops and a bank of optional electric heat turns on to warm air supplying the conditioned space.

APPLICATION DATA

Condensate trap — A 2-in. (51 mm) condensate trap must be field supplied.

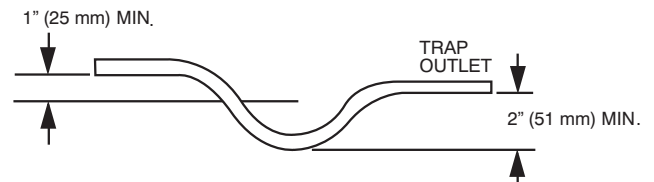

Maximum cooling airflow — To minimize the possibility of condensate blow-off from the evaporator, airflow through the units should not exceed 450 CFM/ton.

Minimum cooling airflow — The minimum cooling airflow is 350 cfm/ton.

Minimum cooling operating outdoor air temperature — All standard units have a minimum ambient operating temperature of 40°F (4.4°C). With accessory low ambient temperature kit, units can operate at temperatures down to 0°F (-17.8°C).

Maximum operating outdoor air temperature — Maximum outdoor operating air temperature for cooling is 125°F (51.7°C).

GUIDE SPECIFICATIONS

SMALL PACKAGED PRODUCT AIR-TO-AIR HEAT PUMP CONSTANT VOLUME APPLICATION

HVAC GUIDE SPECIFICATIONS

SIZE RANGE: 2 TO 5 TONS, NOMINAL (COOLING)

PART I – GENERAL

SYSTEM DESCRIPTION

Outdoor packaged, electrically controlled, air-to-air heat pump utilizing a scroll compressor for heating and cooling duty. Unit shall discharge supply air horizontally as shown on contract drawings.

QUALITY ASSURANCE

A. Unit shall be rated in accordance with AHRI Standards 210/240, and 270. Designed in accordance with UL Standard 1995.

B. Unit shall be designed to conform to ASHRAE 15.

C. Unit shall be UL listed as a total package for safety requirements.

D. Insulation and adhesive shall meet NFPA 90A requirements for flame spread and smoke generation.

DELIVERY, STORAGE, AND HANDLING

Unit shall be stored and handled per manufacturer's recommendations.

PART 2– PRODUCTS

EQUIPMENT

A. General:

Factory-assembled, single piece, air-to-air heat pump. Contained within the unit enclosure shall be all factory wiring, piping, controls, and refrigerant charge (R-410A).

B. Unit Cabinet:

1. Unit cabinet shall be constructed of phosphated, bonderized, zinc-coated, prepainted steel.
2. Basepan shall be made of a single-piece non-corrosive, composite material.
3. Indoor fan compartment cabinet surfaces shall be insulated with a minimum 1/2 in. (12.7 mm) thick, flexible insulation, coated on the air side, with aluminum foil-faced insulation.
4. Cabinet panels shall be easily removable for servicing.
5. Unit shall have a factory-installed, sloped, noncorrosive, condensate drain.
6. Unit insulation conforms to ASHRAE 62P.

C. Fans:

1. Indoor Blower (Indoor Fan):
 - a. Fan shall be multispeed, direct drive as shown on the equipment drawings.
 - b. Fan wheel shall be made from steel, be double-inlet type. It shall have forward-curved blades with a corrosion-resistant finish and shall be dynamically balanced.
2. Outdoor fan shall be of the direct-driven propeller type with aluminum blades, riveted to corrosion-resistant steel spiders. It shall be dynamically balanced, and shall discharge air upwards.

D. Compressor:

Fully-hermetic scroll type with external vibration isolation.

E. Coils:

1. Indoor and outdoor coils shall have aluminum-plate fins mechanically bonded to seamless copper tubes with all joints brazed.
2. Tube sheet openings shall be bellied to prevent tube wear.
3. Outdoor coil shall be protected by metal louvered panels.

F. Refrigerant Components:

1. TXV and AccuRater feed system.
2. Service gauge connections on suction and discharge lines.
3. Equipped with liquid line filter drier.
4. Equipped with accumulators on all sizes.

G. Controls and Safeties:

1. Unit Controls:
 - a. Unit shall be complete with self-contained low voltage control circuit.
 - b. Unit shall incorporate an outdoor coil defrost system to prevent excessive frost accumulation during heating cycle and shall be controlled as follows:
 - (1.) Defrost shall be initiated on the basis of time and coil temperature.
 - (2.) A 30/60/90-minute timer shall activate defrost cycle only if coil temperature is low enough to indicate a heavy frost condition.
 - (3.) Defrost cycle shall terminate when defrost thermostat is satisfied or shall have a positive termination time of 10 minutes.
2. Safeties:
 - a. High Pressure Switch
 - b. Loss of Charge Switch

H. Operating Characteristics:

1. Unit shall be capable of starting and running at 125°F (51.7°C) ambient outdoor temperature.
2. Compressor with standard controls shall be capable of operation down to 40°F (4.4°C) ambient outdoor temperature in cooling duty.
3. Compressor shall be capable of operation in heating cycle down to -20°F (-28.9°C) ambient outdoor-air temperature.
4. Unit shall be capable of simultaneous heating duty and defrost cycle operation when using electric heaters indicated in Section L, Special Features.

I. Electrical Requirements:

All unit power wiring shall enter unit cabinet at a single location.

J. Motors:

1. Compressor motors shall be of the refrigerant-cooled type with line break thermal and current overload protection.
2. All fan motors shall have permanently lubricated bearings and inherent automatic-reset thermal overload protection.
3. Outdoor-fan motor shall be totally enclosed.

GUIDE SPECIFICATIONS (CONT)

K. Grille

- Louvered Grille:
Louvered grille shall be standard on all units.

L. Special Features Available

- Coil Options:
Shall include factory-installed optional tin-plated indoor coil.
- Thermostat:
To provide for two-stage heating and one-stage cooling in addition to manual or automatic changeover and indoor fan control.
- Low-Ambient Package:
Shall consist of a solid-state control and outdoor coil temperature sensor for controlling outdoor fan motor operation, which shall allow unit to operate down to 0°F (-17.8°C) outdoor ambient temperature in cooling.
- Crankcase Heater:
Shall provide anti-floodback protection for low-load cooling applications.
- Electric heaters:
 - Electric heater shall be available as a field-installed option.
 - Heater elements shall be open wire type, adequately supported and insulated with ceramic bushings.
 - Electric heater packages must provide single point power connection capability.
- Compressor Start Kit:
Shall be available to give a boost to the compressor motor at each start-up.
- Outdoor Thermostat Kit:
Thermostat allows for staging of electric heaters based on outdoor air temperature.

PHJ4 ACCESSORIES		
Accessory Model Number	Description	Use With
CPLOWAMB001A00	Low Ambient Control – enables cooling system to operate down to 0 Deg. F by cycling condenser fan on and off.	ALL
CPHSTART002A00	Compressor Start Kit	ALL
CPCRKHTR008A00	240V Crankcase Heater	24 – 36
NPCRKHTR004A00		42 – 48