

INSTALLATION INSTRUCTIONS

R-410A Split Condensing Units with RTPF Coils

CAS072-151

NOTE: Read the entire instruction manual before starting the installation

TABLE OF CONTENTS

<p>SAFETY CONSIDERATIONS 2</p> <p>INSTALLATION GUIDELINES 2</p> <p style="padding-left: 20px;">Replacement/Retrofit — R-22 to R-410A 2</p> <p style="padding-left: 20px;">Rated Indoor Airflow (cfm) 3</p> <p style="padding-left: 20px;">Matching CAS Model to Evaporator Coil 10</p> <p>INSTALLATION 10 - 22</p> <p style="padding-left: 20px;">Jobsite Survey 10</p> <p style="padding-left: 20px;">Step 1 - Plan for Unit Location 10</p> <p style="padding-left: 20px;">Step 2 - Complete Pre-Installation Checks 10</p> <p style="padding-left: 20px;">Step 3 - Prepare Unit Mounting Support 11</p> <p style="padding-left: 20px;">Step 4 - Rig and Mount the Unit 11</p> <p style="padding-left: 20px;">Step 5 - Determine Refrigerant Line Sizes 11</p> <p style="padding-left: 20px;">Step 6 - Complete Refrigerant Piping Connections .. 13</p> <p style="padding-left: 20px;">Step 7 - Install Accessories 17</p> <p style="padding-left: 20px;">Step 8 - Complete Electrical Connections 17</p> <p style="padding-left: 20px;">Step 9 - Wind Baffles for Low Ambient Controls ... 20</p> <p>PRE-START-UP 23</p> <p style="padding-left: 20px;">System Check 23</p> <p style="padding-left: 20px;">Turn On Crankcase Heater 23</p> <p style="padding-left: 20px;">Preliminary Charge 23</p> <p>START-UP 23 - 33</p> <p style="padding-left: 20px;">Preliminary Checks 23</p> <p style="padding-left: 20px;">Start Unit 24</p> <p>OPERATING SEQUENCE 34</p> <p style="padding-left: 20px;">Base Unit Controls 34</p> <p style="padding-left: 20px;">Indoor (Supply) Fan 34</p> <p style="padding-left: 20px;">Cooling, Unit Without Economizer 34</p> <p style="padding-left: 20px;">Cooling, Unit with Economizer 34</p> <p style="padding-left: 20px;">Heating 35</p>	<p>ROUTINE SYSTEM MAINTENANCE 35</p> <p style="padding-left: 20px;">Quarterly Inspection (and 30 days after initial start) ... 35</p> <p style="padding-left: 20px;">Seasonal Maintenance 35</p> <p>SERVICE 35 - 41</p> <p style="padding-left: 20px;">Refrigeration System 35</p> <p style="padding-left: 20px;">Compressor Oil 35</p> <p style="padding-left: 20px;">Servicing Systems on Roofs with Synthetic Materials 35</p> <p style="padding-left: 20px;">Liquid Line Filter Drier 36</p> <p style="padding-left: 20px;">Field Refrigerant Access Ports 36</p> <p style="padding-left: 20px;">Factory High-Flow Access Ports 36</p> <p style="padding-left: 20px;">Comfort Alert Diagnostic Module 36</p> <p style="padding-left: 20px;">Compressor Protection 39</p> <p style="padding-left: 20px;">Crankcase Heater 39</p> <p style="padding-left: 20px;">Low-Pressure Switch 39</p> <p style="padding-left: 20px;">High-Pressure Switch 39</p> <p style="padding-left: 20px;">Outdoor Fans 39</p> <p style="padding-left: 20px;">Lubrication 39</p> <p style="padding-left: 20px;">Routine Cleaning of Round-Tube Plate Fin (RTPF) Coils 42</p> <p style="padding-left: 20px;">Fastener Torque Values 43</p> <p>TROUBLESHOOTING 43 - 44</p> <p>APPENDIX A</p> <p style="padding-left: 20px;">Air Conditioner & Heat Pump with R-410A — Quick Reference Guide 45</p> <p>APPENDIX B</p> <p style="padding-left: 20px;">Wiring Diagram List 45</p> <p>APPENDIX C</p> <p style="padding-left: 20px;">Low Ambient Option — Factory Installed 46</p> <p>START-UP CHECKLIST 51 - 52</p>
--	--

SAFETY CONSIDERATIONS

Improper installation, adjustment, alteration, service, maintenance, or use can cause explosion, fire, electrical shock or other conditions which may cause personal injury or property damage. Consult a qualified installer, service agency, or your distributor or branch for information or assistance. The qualified installer or agency must use factory-authorized kits or accessories when modifying this product. Refer to the individual instructions packaged with the kits or accessories when installing.

Follow all safety codes. Wear safety glasses and work gloves. Use quenching cloths for brazing operations and have a fire extinguisher available. Read these instructions thoroughly and follow all warnings or cautions attached to the unit. Consult local building codes and appropriate national electrical codes (in USA, ANSI/NFPA 70, National Electrical Code (NEC); in Canada, CSA C22.1) for special requirements.

It is important to recognize safety information. This is the safety-alert symbol . When you see this symbol on the unit and in instructions or manuals, be alert to the potential for personal injury.

Understand the signal words DANGER, WARNING, CAUTION, and NOTE. These words are used with the safety-alert symbol. DANGER identifies the most serious hazards which **will** result in severe personal injury or death. WARNING signifies hazards which **could** result in personal injury or death. CAUTION is used to identify unsafe practices, which **may** result in minor personal injury or product and property damage. NOTE is used to highlight suggestions which **will** result in enhanced installation, reliability, or operation.

WARNING

ELECTRICAL SHOCK HAZARD

Failure to follow this warning could cause personal injury or death.

Before performing service or maintenance operations on unit, turn off main power switch to unit and install lock(s) and lockout tag(s). Ensure electrical service to rooftop unit agrees with voltage and amperage listed on the unit rating plate. Unit may have more than one power switch.

WARNING

UNIT OPERATION AND SAFETY HAZARD

Failure to follow this warning could cause personal injury, death and/or equipment damage.

R-410A refrigerant systems operate at higher pressures than standard R-22 systems. Do not use R-22 service equipment or components on R-410A refrigerant equipment.

WARNING

PERSONAL INJURY AND ENVIRONMENTAL HAZARD

Failure to follow this warning could cause personal injury or death.

Relieve pressure and recover all refrigerant before system repair or final unit disposal.

Wear safety glasses and gloves when handling refrigerants. Keep torches and other ignition sources away from refrigerants and oils.

CAUTION

CUT HAZARD

Failure to follow this caution may result in personal injury.

Sheet metal parts may have sharp edges or burrs. Use care and wear appropriate protective clothing, safety glasses and gloves when handling parts and servicing air conditioning equipment.

INSTALLATION GUIDELINE

Replacement/Retrofit — R-22 to R-410A

Replacement/retrofit installations require change-out of outdoor unit, metering device, and filter driers. Change-out of indoor coil (evaporator) and interconnecting tubing is recommended.

Existing evaporator coil – If the existing evaporator coil may be re-used, check with the coil manufacturer to verify the coil construction is suitable for operation with the higher pressures of R-410A. Also determine if the existing TXV valve is compatible with R-410A, replace if necessary. The minimum factory test pressure rating must be 250 psig (1725 kPa). Existing coil will need to be purged with Nitrogen to remove as much mineral oil as possible to eliminate cross contamination of oils.

Acid test – If the existing system is being replaced because of a compressor electrical failure, assume acid is in system. If system is being replaced for any other reason, use an approved acid test kit to determine acid level. If even low levels of acid are detected, install a 100 percent activated alumina suction-line filter drier in addition to the replacement liquid-line filter drier. Remove the suction line filter drier as soon as possible, with a maximum of 72 hr of operation. Recommendation: Install a ball valve in the liquid line at the filter drier location when installing a suction filter in the suction line.

Existing refrigeration piping – Reuse of existing refrigerant piping involves three issues: quality (strength) of existing tubing, cleanliness and tube size. Inspect all tube segments and joints for signs of damage, corrosion or poor brazing. Flush the interconnecting piping system with dry Nitrogen to eliminate as much trace of mineral oil as possible.

Same tube sizes are capable of handling higher flowrates (expressed as tons of cooling capacity) with R-410A refrigerant compared to R-22 at constant pressure drops. For example, a 1/2-inch OD liquid line is rated at 33% higher tons with R-410A than with R-22 (at 5°F pressure drop). A 1 1/8-inch OD suction line is rated at 53% higher tons with R-410A than with R-22 (at 2°F pressure drop). Refrigeration lines selected for R-22 use are typically oversized for R-410A applications. Carefully check the existing suction line size against the table for maximum size (see Table 7); replace vertical riser segments if necessary. Check existing liquid line size against sizing data in Table 5 or 6; replace with smaller lines when feasible.

Installation –

1. Remove the existing evaporator coil or fan coil and install the replacement coil when appropriate.
2. Drain oil from low points and traps in suction line tubing and evaporator if they were not replaced. Removing oil from evaporator coil may require purging of the tubing with dry nitrogen.
3. Unless indoor unit is equipped with a R-410A approved metering device, change the metering device to a thermal expansion valve (TXV) designed for R-410A.
4. Remove the existing outdoor unit. Install the new outdoor unit according to these installation instructions.
5. Install a new field-supplied liquid-line filter drier at the indoor coil just upstream of the TXV or fix orifice metering device.
6. If a suction line filter drier is also to be installed, install suction line drier downstream of suction line service valve at condensing unit.

⚠ CAUTION

UNIT DAMAGE HAZARD

Failure to follow this caution may result in equipment damage or improper operation.
 Never install suction-line filter drier in the liquid-line of a R-410A refrigerant system.

7. If required, install a 100% activated alumina suction line filter drier at the outdoor unit.
8. Evacuate and charge the system according to the instructions in this installation manual.
9. Operate the system for 10 hr. Monitor the pressure drop across the suction line filter drier. If pressure drop exceeds 3 psig (21kPa), replace suction-line and liquid-line filter driers. Be sure to purge system with dry nitrogen and evacuate when replacing filter driers. Continue to monitor the pressure drop across suction-line filter drier. Repeat filter changes if necessary. Never leave suction-line filter drier in system longer than 72 hr (actual time).

Rated Indoor Airflow (cfm)

The table below lists the rated indoor airflow used for the AHRI efficiency rating for the units covered in this document.

CAS (Single Circuit) with FAS

Model Numbers	Full Load Airflow (cfm)
CAS072*A/B – FAS072	2400
CAS072*G/H – FAS072	2625
CAS091 – FAS091	3000
CAS121 – FAS120	4000
CAS151 – FAS150	4375

CAS (Dual Circuit) with FAS

Model Numbers	Full Load Airflow (cfm)
CAS120 – FAS120	4000
CAS150 – FAS150	4400

MODEL SERIES	C	A	S	0	9	1	H	G	A	0	A	0	0	A
Position Number	1	2	3	4	5	6	7	8	9	10	11	12	13	14
C = R-410A Condensing Unit														
A = Air Conditioning (Cooling Only)	Type													
S = Standard Efficiency	Efficiency													
072 = 6 Tons 091 = 7.5 Tons (1 circuit) 120 = 10 Tons (2 circuits) 121 = 10 Tons (1 circuit) 150 = 12.5 Tons (2 circuits) 151 = 12.5 Tons (1 circuit)	Nominal Cooling Capacity													
H = 208/230-3-60 L = 460-3-60 S = 575-3-60	Voltage													
A = Single Circuit B = Single Circuit with Low Ambient Controller D = Dual Circuit E = Dual Circuit with Low Ambient Controller G = Single Circuit / Dual Stage H = Single Circuit / Dual Stage with Low Ambient Controller	Refrigerant Options													
A = Cu/Al B = Precoat Cu/Al C = E-Coat Cu/Al E = Cu/Cu M = Cu/Al with Louvered Hail Guards M = Precoat Cu/Al with Louvered Hail Guards P = E-Coat Cu/Al with Louvered Hail Guards R = Cu/Cu with Louvered Hail Guards	Coil Options													
0 = None 1 = Un-powered Convenience Outlet	Service Options													
A = None C = Non-Fused Disconnect	Electrical Options													
0 = Electro-Mechanical Controls (standard)	Base Unit Controls													
0 = Not Used	Not Used													
A = Original Design	Sales Code													

C150351

Fig. 1 - Model Number Nomenclature

NOTES:

1. MINIMUM CLEARANCE (LOCAL CODES OR JURISDICTION MAY PREVAIL):
 - A. BOTTOM TO COMBUSTIBLE SURFACES: 0 INCHES.
 - B. OUTDOOR COIL, FOR PROPER AIR FLOW: 36 INCHES ONE SIDE, 12 INCHES THE OTHER. THE SIDE GETTING THE GREATER CLEARANCE IS OPTIONAL. STANDARD CLEARANCES ON REMAINING TWO SIDES.
 - C. OVERHEAD: 60 INCHES, TO ASSURE PROPER OUTDOOR FAN OPERATION.
 - D. BETWEEN UNITS: CONTROL BOX SIDE, 42 INCHES PER NEC.
 - E. BETWEEN UNIT AND UNGROUNDED SURFACES: CONTROL BOX SIDE, 36 INCHES PER NEC.
 - F. BETWEEN UNIT AND BLOCK OR CONCRETE WALLS AND OTHER GROUNDED SURFACES: CONTROL BOX SIDE, 42 INCHES PER NEC.
2. WITH EXCEPTION OF THE CLEARANCE FOR THE OUTDOOR COIL AS STATED IN NOTE 1B, A REMOVABLE FENCE OR BARRICADE REQUIRES NO CLEARANCE.
3. UNITS MAY BE INSTALLED ON COMBUSTIBLE FLOORS MADE FROM WOOD OR CLASS A, B OR C ROOF COVERING MATERIAL.

CG CENTER OF GRAVITY

➔ DIRECTION OF AIR FLOW

DIMENSIONS IN [] ARE IN MILLIMETERS.

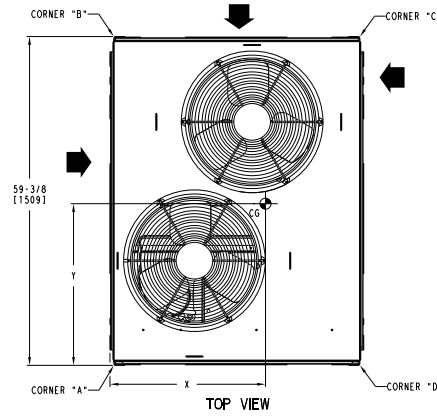

SERVICE VALVE CONNECTIONS				QTY
UNIT	SUCTION	LIQUID		
CAS072	1-1/8 [28.6]	3/8 [9.5]		1
CAS091	1-1/8 [28.6]	1/2 [12.7]		1
CAS121	1-3/8 [34.9]	1/2 [12.7]		1
CAS151	1-3/8 [34.9]	5/8 [15.9]		1
CAS120	1-1/8 [28.6]	3/8 [9.5]		2
CAS150	1-3/8 [34.9]	1/2 [12.7]		2

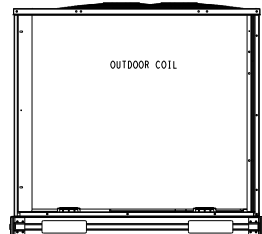
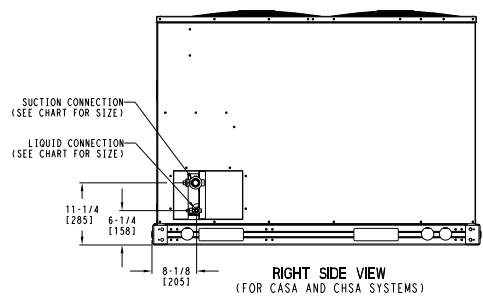
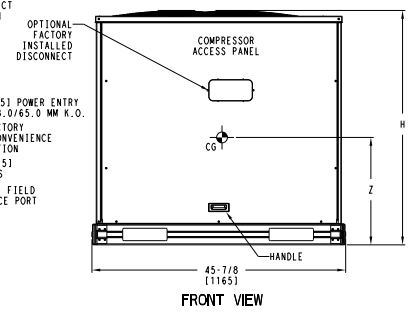
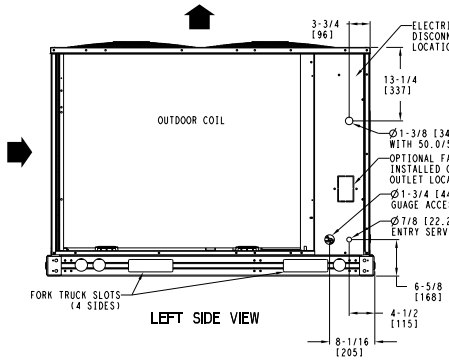
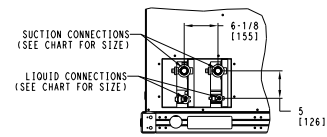

REAR VIEW

C150352

UNIT	STD. UNIT WT.		CORNER A		CORNER B		CORNER C		CORNER D		CENTER OF GRAVITY			UNIT HEIGHT
	lbs.	kg.	lbs.	kg.	lbs.	kg.	lbs.	kg.	lbs.	kg.	X	Y	Z	H
CAS072	389	176	141	64	96	44	62	28	91	41	18 [457.2]	24 [609.6]	21 [533.4]	42 3/8 [1076.0]
CAS091	391	177	142	64	96	44	62	28	91	41	18 [457.2]	24 [609.6]	21 [533.4]	42 3/8 [1076.0]
CAS121	490	222	177	80	120	54	78	35	114	52	18 [457.2]	24 [609.6]	24 [609.6]	50 3/8 [1279.2]
CAS120	516	234	185	84	117	53	83	38	131	59	19 [482.6]	23 [584.2]	24 [609.6]	50 3/8 [1279.2]
CAS151	598	271	195	88	142	64	110	50	151	68	20 [508.0]	25 [635.0]	24 [609.6]	50 3/8 [1279.2]
CAS150	654	297	214	97	155	70	120	54	165	75	20 [508.0]	25 [635.0]	24 [609.6]	50 3/8 [1279.2]

LEGEND: RTPF = Round Tube/Plate Fin coil

Fig. 2 - CAS072-151 Unit Dimensions

Table 1A — Physical Data — CAS072-151 Units — 60 Hz English

UNIT	CAS072*A/B	CAS072*G/H	CAS091*A/B	CAS121	CAS151
NOMINAL CAPACITY (tons)	6	6	7.5	10	12.5
OPERATING WEIGHTS (lb)					
Round Tube/Plate Fin Coil (Cu/Al)	389	389	391	490	598
REFRIGERANT TYPE‡	R-410A	R-410A	R-410A	R-410A	R-410A
Operating Charge (w/ fan coil), Typical (lb)†	14.0	14.0	17.0	20.0	43.0
Shipping Charge (lb)	9.0	9.0	9.0	9.0	9.0
COMPRESSOR					
Qty...Type	1...Scroll	1...2 Stage Scroll	1...Scroll	1...Scroll	1...Scroll
Oil Charge (oz)	56	56	60	110	110
CONDENSER FANS					
Qty...Rpm	2...1100	2...1100	2...1100	2...1100	2...1100
Motor Hp	1/4	1/4	1/4	1/4	1/4
Diameter	22	22	22	22	22
Nominal Airflow (Cfm Total)	6000	6000	6000	6000	6000
Watts (Total)	610	610	610	610	610
RTPF CONDENSER COIL					
Material (Tube/Fin)	Cu / Al	Cu / Al	Cu / Al	Cu / Al	Cu / Al
Coil Type	3/8-in RTPF	3/8-in RTPF	3/8-in RTPF	3/8-in RTPF	3/8-in RTPF
Rows/Fins per inch (FPI)	2 / 17	2 / 17	2 / 17	2 / 17	3 / 17
Face Area (sq ft total)	17.5	17.5	17.5	25.1	31.8
CONTROLS					
Pressurestat Settings (psig)					
High Cutout	630 ± 10	630 ± 10	630 ± 10	630 ± 10	630 ± 10
Cut-in	505 ± 20	505 ± 20	505 ± 20	505 ± 20	505 ± 20
Low Cutout	54 ± 3	54 ± 3	54 ± 3	54 ± 3	54 ± 3
Cut-in	117 ± 5	117 ± 5	117 ± 5	117 ± 5	117 ± 5
PIPING CONNECTIONS (in. ODS)					
Qty...Suction	1...1 1/8	1...1 1/8	1...1 1/8	1...1 3/8	1...1 3/8
Qty...Liquid	1...3/8	1...3/8	1...1/2	1...1/2	1...5/8

LEGEND

RTPF — Round Tube/Plate Fin
ODS — Outside Diameter Sweat (socket)

‡ Unit is factory-supplied with partial charge only.

† Typical operating charge with 25 ft of interconnecting piping.

Table 1B — Physical Data — CAS072-151 Units — 60 Hz SI

UNIT	CAS072*A/B	CAS072*G/H	CAS091*A/B	CAS121	CAS151
NOMINAL CAPACITY (kW)	21.1	21.1	26.4	35.1	44
OPERATING WEIGHTS (lb)					
Round Tube/Plate Fin Coil (Cu/Al)	176	176	177	222	271
REFRIGERANT TYPE‡	R-410A	R-410A	R-410A	R-410A	R-410A
Operating Charge (w/ fan coil), Typical (kg)†	6.4	6.4	7.7	9.1	19.5
Shipping Charge (kg)	4.1	4.1	4.1	4.1	4.1
COMPRESSOR					
Qty...Type	1...Scroll	1...2 Stage Scroll	1...Scroll	1...Scroll	1...Scroll
Oil Charge (oz)	1.7	1.7	1.8	3.3	3.3
CONDENSER FANS					
Qty...r/s	2...18	2...18	2...18	2...18	2...18
Motor Hp NEMA	1/4	1/4	1/4	1/4	1/4
Diameter (mm)	560	560	560	560	560
Nominal Airflow (L/s)	2832	2832	2832	2832	2832
Watts (Total)	610	610	610	610	610
RTPF CONDENSER COIL					
Material (Tube/Fin)	Cu / Al	Cu / Al	Cu / Al	Cu / Al	Cu / Al
Coil Type	3/8-in RTPF	3/8-in RTPF	3/8-in RTPF	3/8-in RTPF	3/8-in RTPF
Rows/Fins per Meter (Fins/m)	2 / 670	2 / 670	2 / 670	2 / 670	3 / 670
Face Area (sq m total)	1.6	1.6	1.6	2.3	3.0
CONTROLS					
Pressurestat Settings (kPa)					
High Cutout	4347 ± 70	4347 ± 70	4347 ± 70	4347 ± 70	4347 ± 70
Cut-in	3482 ± 138	3482 ± 138	3482 ± 138	3482 ± 138	3482 ± 138
Low Cutout	372 ± 21	372 ± 21	372 ± 21	372 ± 21	372 ± 21
Cut-in	807± 34	807± 34	807± 34	807± 34	807± 34
PIPING CONNECTIONS (in. ODS)					
Qty...Suction	1...1 1/8	1...1 1/8	1...1 1/8	1...1 3/8	1...1 3/8
Qty...Liquid	1...3/8	1...3/8	1...1/2	1...1/2	1...5/8

LEGEND

RTPF — Round Tube/Plate Fin
NEMA — National Electrical Manufacturers Association
ODS — Outside Diameter Sweat (socket)

‡ Unit is factory-supplied with partial charge only.

† Typical operating charge with 25 ft of interconnecting piping.

Table 2A — Physical Data — CAS120-150 Units — 60 Hz English

UNIT	CAS120	CAS150
NOMINAL CAPACITY (tons)	10	12.5
OPERATING WEIGHTS (lb)		
Round Tube/Plate Fin Coil (Cu/Al)	516	654
REFRIGERANT TYPE‡	R-410A	R-410A
Operating Charge 1/2 (w/ fan coil), Typical (lb)†	11.0 / 11.0	22.0/22.0
Shipping Charge 1/2 (lb)	9.0 / 9.0	9.0/9.0
COMPRESSOR		
Qty...Type	2...Scroll	2...Scroll
Oil Charge 1/2 (oz)	42	60
CONDENSER FANS		
Qty...Rpm	2...1100	2...1100
Motor Hp	1/4	1/4
Diameter	22	22
Nominal Airflow (Cfm Total)	6000	6000
Watts (Total)	610	610
RTPF CONDENSER COIL		
Material (Tube/Fin)	Cu / Al	Cu / Al
Coil Type	3/8-in RTPF	3/8-in RTPF
Rows/Fins per inch (FPI)	2 / 17	3 / 17
Face Area (sq ft total)	25.1	31.8
CONTROLS		
Pressurestat Settings (psig)		
High Cutout	630 ± 10	630 ± 10
Cut-in	505 ± 20	505 ± 20
Low Cutout	54 ± 3	54 ± 3
Cut-in	117 ± 5	117 ± 5
PIPING CONNECTIONS (in. ODS)		
Qty...Suction 1/2	1...1 1/8 / 1...1 1/8	1...1 3/8 / 1...1 3/8
Qty...Liquid 1/2	1...3/8 / 1...3/8	1...1/2 / 1...1/2

LEGEND

RTPF — Round Tube/Plate Fin
ODS — Outside Diameter Sweat (socket)

‡ Unit is factory-supplied with partial charge only.

† Typical operating charge with 25 ft of interconnecting piping.

Table 2B — Physical Data — CAS120-150 Units — 60 Hz SI

UNIT	CAS120	CAS150
NOMINAL CAPACITY (kW)	35.1	44
OPERATING WEIGHTS (kg)		
Round Tube/Plate Fin Coil (Cu/Al)	234	297
REFRIGERANT TYPE‡	R-410A	R-410A
Operating Charge 1/2 (w/ fan coil), Typical (kg)†	5.0 / 5.0	10.0 / 10.0
Shipping Charge 1/2 (kg)	4.1 / 4.1	4.1 / 4.1
COMPRESSOR		
Qty...Type	2...Scroll	2...Scroll
Oil Charge 1/2 (L)	1.2	1.7
CONDENSER FANS		
Qty...r/s	2...1100	2...1100
Motor Hp NEMA	1/4	1/4
Diameter (mm)	560	560
Nominal Airflow (Cfm Total)	6000	6000
Watts (Total)	610	610
RTPF CONDENSER COIL		
Material (Tube/Fin)	Cu / Al	Cu / Al
Coil Type	3/8-in RTPF	3/8-in RTPF
Rows/Fins per Meter (Fins/m)	2 / 670	3 / 670
Face Area (sq m total)	2.3	3.0
CONTROLS		
Pressurestat Settings (kPa)		
High Cutout	4347 ± 70	4347 ± 70
Cut-in	3482 ± 138	3482 ± 138
Low Cutout	372 ± 21	372 ± 21
Cut-in	807 ± 34	807 ± 34
PIPING CONNECTIONS (in. ODS)		
Qty...Suction 1/2	1...1 1/8 / 1...1 1/8	1...1 3/8 / 1...1 3/8
Qty...Liquid 1/2	1...3/8 / 1...3/8	1...1/2 / 1...1/2

LEGEND

RTPF — Round Tube/Plate Fin
NEMA — National Electrical Manufacturers Association
ODS — Outside Diameter Sweat (socket)

‡ Unit is factory-supplied with partial charge only.

† Typical operating charge with 7.62 m of interconnecting piping.

Matching CAS Model to Evaporator Coil

The CAS072, 091, 121, 151 models have a single-circuit unit design, requiring one set of refrigeration piping. This model can be connected to an evaporator coil with one circuit or with two circuits (by manifolding the evaporator connections into a single piping system).

The CAS120, 150 is a dual-circuit unit design that requires two sets of refrigeration piping between the outdoor unit and the evaporator coil (or coils). This model can only be connected to an evaporator coil that has two refrigeration circuits (or to two separate evaporator coils). The CAS120, 150 CANNOT be connected to a single-circuit evaporator coil and it CANNOT be field-converted to a single-circuit design.

Table 3 – Evaporator Coil Connections

Evaporator Coil has	Connect to Model	Notes
Single Circuit	CAS072, 091, 121, 151	
Two Circuits	CAS072, 091, 121, 151 Or CAS120, 150	Manifold evaporator circuits into single piping system Use two separate piping systems

Before unpacking this new CAS model, compare the evaporator coil design to the CAS model.

INSTALLATION

Jobsite Survey

Complete the following checks before installation.

1. Consult local building codes and the NEC (National Electrical Code) ANSI/NFPA 70 for special installation requirements.
2. Determine unit location (from project plans) or select unit location.
3. Check for possible overhead obstructions which may interfere with unit lifting or rigging.

Step 1 — Plan for Unit Location

CAS units are designed and approved for outdoor installation only. Do not locate these units indoors. Do not add ducting to unit fan system.

Select a location for the unit and its support system (pad, rails or other) that provides for the minimum clearances required for safety. This includes the clearance to combustible surfaces, unit performance and service access below, around and above unit as specified in unit drawings. See Fig. 3.

NOTE: Local codes may require different clearances than specified in Fig. 4. It is the responsibility of installers to be knowledgeable in local codes and to modify the recommended clearances to satisfy local codes.

NOTE: Consider also the effect of adjacent units on airflow performance and control box safety clearance.

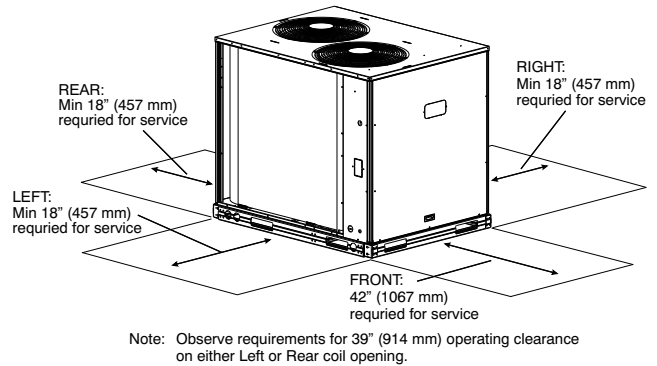

Fig. 3 - Service Clearance Dimensional Drawing

Do not install the outdoor unit in an area where fresh air supply to the outdoor coil may be restricted or when recirculation from the condenser fan discharge is possible. Do not locate the unit in a well or next to high walls.

Evaluate the path and required line length for interconnecting refrigeration piping, including suction riser requirements (outdoor unit above indoor unit) and liquid line lift (outdoor unit below indoor unit). Relocate sections to minimize the length of interconnecting tubing.

DO NOT BURY REFRIGERATION LINES.

Although unit is weatherproof, avoid locations that permit water from higher level runoff and overhangs to fall onto the unit.

Step 2 — Complete Pre-Installation Checks

Check Unit Electrical Characteristics: Confirm before installation of unit that voltage, amperage and circuit protection requirements listed on unit data plate agree with power supply provided.

Un-crate Unit: Remove unit packaging except for the top skid assembly, which should be left in place until after the unit is rigged into its final location.

Inspect Shipment: File a claim with shipping company if the shipment is damaged or incomplete.

Consider System Requirements:

- Consult local building codes and National Electrical Code (NEC, U.S.A.) for special installation requirements.
- Allow sufficient space for airflow clearance, wiring, refrigerant piping, and servicing unit. See Fig. 2 for unit dimensions and weight distribution data.
- Locate the unit so that the outdoor coil (condenser) airflow is unrestricted on all sides and above.
- The unit may be mounted on a level pad directly on the base channels or mounted on raised pads at support points. See Tables 1A through 2B for unit operating weights. See Fig. 2 for weight distribution based on recommended support points.

NOTE: If vibration isolators are required for a particular installation, use the data in Fig. 2 to make the proper selection.

Step 3 — Prepare Unit Mounting Support

Slab Mount —

Provide a level concrete slab that extends a minimum of 6 in. (150 mm) beyond unit cabinet. Install a gravel apron in front of condenser coil air inlet to prevent grass and foliage from obstructing airflow.

Step 4 — Rig and Mount the Unit

⚠ CAUTION
UNIT DAMAGE HAZARD
Failure to follow this caution may result in equipment damage.
All panels must be in place when rigging. Unit is not designed for handling by fork truck.

Rigging: These units are designed for overhead rigging. Refer to the rigging label for preferred rigging method. Spreader bars are not required if top crating is left on the unit. All panels must be in place when rigging. As further protection for coil faces, plywood sheets may be placed against the sides of the unit, behind cables. Run cables to a central suspension point so that the angle from the horizontal is not less than 45 degrees. Raise and set the unit down carefully.

If it is necessary to roll the unit into position, mount the unit on longitudinal rails, using a minimum of 3 rollers. Apply force to the rails, not the unit. If the unit is to be skidded into position, place it on a large pad and drag it by the pad. Do not apply any force to the unit.

Raise from above to lift the unit from the rails or pad when unit is in its final position.

After the unit is in position, remove all shipping materials and top crating.

Step 5 — Determine Refrigerant Line Sizes

Select the recommended line sizes for CAS072, 091, 121, 151 and CAS120, 150 unit from the appropriate tables.

Determine the linear length of interconnecting piping required between the outdoor unit and indoor unit (evaporator). Consider and identify also the arrangement of the tubing path (quantity and type of elbows in both lines), liquid line solenoid size, filter drier and any other refrigeration specialties located in the liquid line. Refer to the indoor unit installation instructions for additional details on refrigeration specialties devices.

Determine equivalent line length adjustments for path and components and add to linear line lengths. See Table 4, Equivalent Lengths for Common Fittings, for usual fitting types. Also identify adjustments for refrigeration specialties. Refer to the indoor unit installation instructions for additional information.

Table 4 – Equivalent Lengths for Common Fittings (ft)

Nominal Tube OD	Elbows				
	90° Std	90° Lrad	90° Street	45° Std	45° Street
3/8	1.3	0.8	2.2	0.6	1
1/2	1.4	0.9	2.3	0.7	1.1
5/8	1.6	1	2.5	0.8	1.3
3/4	1.8	1.2	2.9	0.9	1.5
7/8	2	1.4	3.2	0.9	1.6
1 1/8	2.6	1.7	4.1	1.3	2.1
1 3/8	3.3	2.3	5.6	1.7	3
1 5/8	4	2.6	6.3	2.1	3.4
2 1/8	5	3.3	8.2	2.6	4.5

Nominal Tube OD	Tees			
	Branch Flow	Straight-Thru		
		No Reduct	Reduce 25%	Reduce 50%
3/8	2.6	0.8	1.1	1.3
1/2	2.7	0.9	1.2	1.4
5/8	3	1	1.4	1.6
3/4	3.5	1.2	1.7	1.8
7/8	4	1.4	1.9	2
1 1/8	5	1.7	2.3	2.6
1 3/8	7	2.3	3.1	3.3
1 5/8	8	2.6	3.7	4
2 1/8	10	3.3	4.7	5

NOTE: Equivalent line lengths will vary based on tube diameter. Calculate equivalent line length for each pipe by adding equivalent length adjustments to linear lengths for each pipe.

Enter the appropriate table to select the recommended line sizes.

Model	Line Size Table	Quantity of Line Sets
CAS072, 091, 121, 151	5	1
CAS120, 150	6	2

Liquid Lift —

A liquid lift condition exists when the outdoor unit is located below the indoor (evaporator) unit and liquid flows vertically up in a portion of the liquid line. The vertical column of liquid reduces the available state point subcooling at the evaporator coil's thermal expansion valve. This effect reduces the length of liquid lift (feet of elevation) that a liquid line size can accommodate. Longer linear tube lengths will also reduce the amount of liquid lift possible.

Check Tables 5 (CAS072, 091, 121, 151) and 6 (CAS120, 150) for maximum liquid lift capabilities for line sizes. Reselect the liquid line tube size if necessary. If maximum available tube size cannot provide the required lift distance on this installation, relocate the outdoor unit to reduce the equivalent line length or the lift requirement.

Table 5 – CAS072, 091, 121, 151 Piping Recommendations (Single-Circuit Unit)

Linear Length	Ft	0 – 25	25 – 50	50 – 75	75 – 100	100 – 125				
	m	0 – 8	8 – 15	15 – 23	23 – 30	30 – 38				
Equivalent Length	Ft	0 – 38	38 – 75	75 – 113	113 – 150	150 – 188				
	m	0 – 12	12 – 23	23 – 34	34 – 46	46 – 57				
Model										
CAS072	Liquid Line size	3/8"	3/8"	1/2"	1/2"	5/8"	1/2"	5/8"	1/2"	5/8"
	Liquid PD (°F)	2.0	4.0	0.7	1.1	0.3	1.4	0.4	1.8	0.5
	Max Lift	18	7	34	31	39	44	57	41	57
	Max Lift PD (°F)	3.5	4.6	3.5	3.5	3.5	5.0	5.0	5.0	5.0
	Suction Line size	7/8"	7/8"	1-1/8"	7/8"	1-1/8"	7/8"	1-1/8"	7/8"	1-1/8"
	Suction Ln PD(°F)	0.9	1.8	0.5	2.7	0.8	3.6	1.0	4.5	1.3
	Charge	10.8	11.8	13.7	15.2	18.5	16.9	21.3	18.7	24.2
	#/TR	1.90	2.07	2.41	2.67	3.25	2.97	3.74	3.28	4.25
CAS091	Liquid Line size	1/2"	1/2"	5/8"	1/2"	5/8"	1/2"	5/8"	1/2"	5/8"
	Liquid PD (°F)	0.6	1.3	0.3	1.9	0.5	2.5	0.7	3.2	0.9
	Max Lift	25	50	50	75	75	100	100	97	97
	Max Lift PD (°F)	2.7	5.4	4.5	8.1	6.7	10.8	9.0	11.2	8.9
	Suction Line size	7/8"	7/8"	1-1/8"	7/8"	1-1/8"	1-1/8"		1-1/8"	1-3/8"
	Suction Ln PD(°F)	1.5	3.1	0.8	4.6	1.2	1.6		2.1	0.7
	Charge	13.6	15.4	16.1	17.2	20.5	19.5	23.3	21.5	27.1
	#/TR	1.78	2.02	2.11	2.25	2.68	2.55	3.05	2.81	3.54
CAS121	Liquid Line size	1/2"	1/2"	5/8"	1/2"	5/8"	1/2"	5/8"	1/2"	5/8"
	Liquid PD (°F)	0.9	1.9	0.5	2.8	0.8	3.8	1.0	4.7	1.3
	Max Lift	25	40	50	28	54	34	68	22	65
	Max Lift PD (°F)	2.9	5.0	4.5	5.0	5.0	6.5	6.4	6.5	6.4
	Suction Line size	7/8"	7/8"	1-1/8"	1-1/8"	1-3/8"	1-1/8"	1-3/8"	1-1/8"	1-3/8"
	Suction Ln PD(°F)	2.4	4.8	1.2	1.8	0.6	2.4	0.9	3.1	1.1
	Charge	15.7	17.5	19.7	19.8	23.1	21.6	26.1	23.6	29.2
	#/TR	1.67	1.86	2.09	2.10	2.45	2.29	2.77	2.50	3.10
CAS151	Liquid Line size	5/8"	5/8"	3/4"	5/8"	3/4"	5/8"	3/4"	5/8"	3/4"
	Liquid PD (°F)	0.4	0.8	0.4	1.2	0.6	1.6	0.8	2.0	1.1
	Max Lift	23	16	23	10	18	28	38	21	36
	Max Lift PD (°F)	1.8	1.84	1.84	1.8	1.8	3.3	3.3	3.3	3.3
	Suction Line size	1-1/8"	1-1/8"	1-3/8"	1-1/8"	1-3/8"	1-3/8"		1-3/8"	1-5/8"
	Suction Ln PD(°F) (Cap Red)	1.1	2.2	0.8	3.3 (-2.3%)	1.2	1.6		2.0	0.8
	Charge	31.8	34.7	37.6	37.6	41.8	41.1	46.1	44.2	51.6
	#/TR	2.62	2.86	3.09	3.09	3.44	3.38	3.79	3.64	4.24
Legend:										
TC	Total Capacity, MBH (at 45 F Saturated suction, 95 F outdoor air temp)									
SC	Sub-cooling, degrees F (at liquid line valve)									
Liquid PD (°F)	Liquid line pressure drop, saturated temperature, degrees F									
Max Lift	Maximum liquid lift (Indoor unit ABOVE outdoor unit only), at maximum permitted pressure drop.									
Max Lift PD (°F)	Pressure drop including Maximum liquid lift value									
Suction Ln PD(°F)	Suction line pressure drop, saturated temperature, degree F									
(Cap Red)	Capacity reduction caused by suction line pressure drop GT 2 deg F									
#/TR	Charge to unit capacity ratio, lbs per ton (at 45 F SST, 95 F ODA)									
NOTE:	For applications with equivalent length greater than 188 ft (57 m) and/or linear length greater than 125 ft (38 m), contact your local service representative.									

Table 6 – CAS120, 150 Piping Recommendations (Two-Circuit Unit)

NOTE: CAS120, 150 requires TWO sets of refrigeration piping								
Linear Length	Ft	0 – 25	25 – 50	50 – 75	75 – 100	100 – 125		
	m	0 – 8	8 – 15	15 – 23	23 – 30	30 – 38		
Equivalent Length	Ft	0 – 38	38 – 75	75 – 113	113 – 150	150 – 188		
	m	0 – 12	12 – 23	23 – 34	34 – 46	46 – 57		
Model								
CAS120	Liquid Line size	3/8"	3/8"	3/8"	3/8"	1/2"	3/8"	1/2"
	Liquid PD (°F)	1.4	2.7	5.5	5.5	0.9	6.9	1.1
	Max Lift	25	50	75	82	100	66	125
	Max Lift PD (°F)	3.4	6.8	10.2	12.1	9.0	12.1	11.2
	Suction Line size	3/4"	7/8"	7/8"	7/8"	1-1/8"	7/8"	1-1/8"
	Suction Ln PD(°F) (Cap Red)	1.4	1.2	1.8	2.5 (-0.8%)	0.8	3.1 (-1.9%)	0.9
	Charge	9.0	10.0	11.0	12.1	15.7	13.1	17.7
	#/TR	0.73	0.81	0.89	0.97	1.27	1.05	1.42
CAS150	Liquid Line size	3/8"	3/8"	3/8"	3/8"	1/2"	3/8"	1/2"
	Liquid PD (°F)	2.1	4.1	6.2	8.2	1.5	10.3	1.8
	Max Lift	128	50	75	69	155	42	125
	Max Lift PD (°F)	4.0	8.1	12.1	13.6	9.4	13.6	11.7
	Suction Line size	7/8"	7/8"	7/8"	1-1/8"	1-1/8"	1-1/8"	
	Suction Ln PD(°F) (Cap Red)	1.0	1.9	2.9 (-1.5%)	0.8	1.1	1.4	
	Charge	17.0	18.0	19.0	19.5	20.6	23.7	21.8
	#/TR	1.36	1.44	1.52	1.56	1.65	1.90	1.74
Legend:								
TC	Total Capacity, MBH (at 45 F Saturated suction, 95 F outdoor air temp)							
SC	Sub-cooling, degrees F (at liquid line valve)							
Liquid PD (°F)	Liquid line pressure drop, saturated temperature, degrees F							
Max Lift	Maximum liquid lift (Indoor unit ABOVE outdoor unit only), at maximum permitted pressure drop.							
Max Lift PD (°F)	Pressure drop including Maximum liquid lift value							
Suction Ln PD(°F)	Suction line pressure drop, saturated temperature, degree F							
(Cap Red)	Capacity reduction caused by suction line pressure drop GT 2 deg F							
#/TR	Charge to unit capacity ratio, lbs per ton (at 45 F SST, 95 F ODA)							
NOTE:	For applications with equivalent length greater than 188 ft (57 m) and/or linear length greater than 125 ft (38 m), contact your local service representative.							

Suction Riser —

A suction riser condition exists when the outdoor unit is located above the indoor (evaporator) unit and suction vapor must flow vertically up to return to the compressor. Oil return is a concern when the suction tube size is too large to produce the minimum refrigerant velocity to ensure oil return at minimum load conditions.

Check Table 7 for maximum suction tube size for CAS units at minimum load conditions. Consider suction speed riser (reduced tube size for vertical segment only) or double suction riser arrangement if the planned suction tube size does not provide necessary minimum flowrates for this riser.

Table 7 – CAS Maximum Suction Pipe Size

CAS Model:	Maximum Tube Size
072*A/B	1 3/8
072*G/H	1 1/8
091*A/B	1 5/8
121*A/B	1 5/8
151*A/B	2 1/8
120*D/E	1 3/8
150*D/E	1 5/8

Vertical Separation (outdoor unit above indoor unit) –

Vertical elevation difference of 200 ft (60 m) is permitted when the outdoor unit (CAS072, 091, 121, 151 or CAS120, 150) is located above the indoor unit.

Step 6 — Complete Refrigerant Piping Connections

IMPORTANT: Do not bury refrigerant piping underground.

IMPORTANT: A refrigerant receiver is not provided with the unit. Do not install a receiver.

Provide Safety Relief —

If local codes dictate an additional safety relief device, purchase locally and install locally. Installation will require the recovery of the factory shipping charge before the factory tubing can be cut and the supplemental relief device is installed.

Model CAS120, 150 has two separate refrigeration systems. If required, each circuit will require a field-supplied/installed supplemental relief device.

Check CAS Model with Evaporator Coil Connections —

Confirm before installation of unit that the evaporator coil connections are consistent with this CAS model. See Table 3 on page 10.

Insulate Suction Lines —

Apply closed-cell tubular insulation to all suction lines between evaporator coil connection and CAS unit's suction service valve.

CAS120, 150 Piping Connections —

The CAS120, 150's two circuits are designated Circuit 1 and Circuit 2. Circuit 1 is controlled by the thermostat's Y1 (or TC1) contact and will be the first circuit on and last circuit off. Circuit 2 is controlled by the thermostat's Y2 (or TC2) contact and this circuit is always the "lag" circuit.

See Fig. 4 for location of Circuit 1 and Circuit 2 service valves and field piping connections. Circuit 1 is on the right-hand side of the service valve compartment; Circuit 2 is on the left.

When a single piece evaporator coil with two separate circuits is connected to a CAS120, 150, the lower coil circuit should be connected to the CAS120, 150's Circuit 1 so that the evaporator's lower coil segment is first-on/last-off (to avoid re-evaporation of condensate on dry lower coil segments).

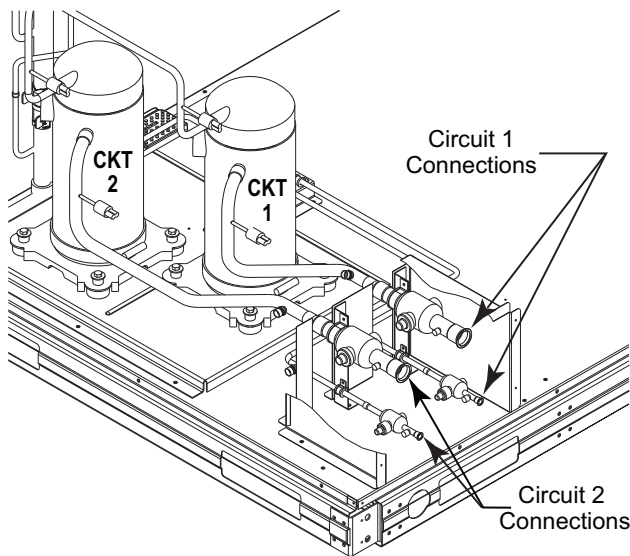

C10912

Fig. 4 - CAS120, 150 Service Valve Locations

Plan the Circuit 1 and Circuit 2 tubing segments carefully, mark each segment and check constantly as piping systems are assembled to avoid piping errors.

CAS120, 150 unit cannot be field-piped as a single-circuit/tandem system.

Final Tubing Check. CAS120, 150 —

Before completing the field piping connections to the CAS120, 150 unit service valves, confirm that the suction line to the indoor coil's first-on/last-off circuit (and its companion liquid line) are correctly identified as Circuit 1 use for the CAS120, 150 unit. If a suction riser is required, it must be in Circuit 1.

Connecting FAS to CAS120, 150: The FAS fan coil in 10, 12.5, and 15 ton sizes is a face-split coil design that also has its circuits designated as 1 and 2. See Fig. 5. Note that the lower coil segment changes as the arrangement of the FAS changes. In a vertical arrangement, the FAS's lower coil segment is segment 2; this segment should be connected to the CAS120, 150's Circuit 1. In a horizontal arrangement, the FAS's lower segment is now segment 1; this segment should be connected to the CAS120, 150's Circuit 1.

Note that refrigerant suction piping should be insulated.

FAS Arrangement	Cooling Stage	FAS Coil Segment	Connect to CAS120, 150
Vertical	Y1	2	Circuit 1
	Y2	1	Circuit 2
Horizontal	Y1	1	Circuit 1
	Y2	2	Circuit 2

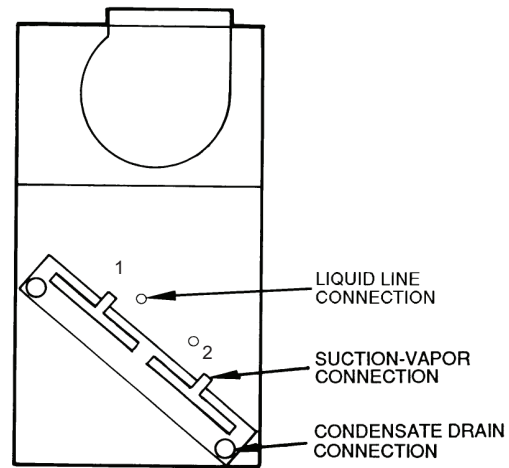

FIRST ON/LAST OFF = 2
VERTICAL INSTALLATION

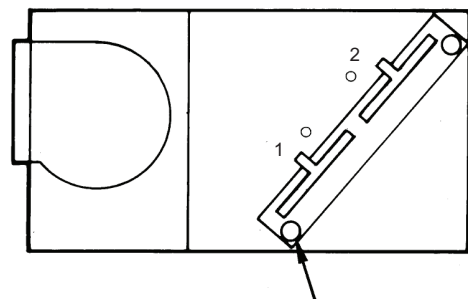

CONDENSATE DRAIN CONNECTION
FIRST ON/LAST OFF = 1
HORIZONTAL INSTALLATION

C10071

Fig. 5 - Typical Evaporator Coil Connections (FAS)

Install Filter Drier(s) and Moisture Indicator(s) —

Every unit MUST have a filter drier in the liquid line. CAS120, 150 models require two filter driers (one in each liquid line). Locate the filter drier(s) at the indoor unit, close to the evaporator coil's thermal expansion valve (TXV) inlets.

CAS units include one (CAS072, 091, 121, 151) or two (CAS120, 150) R-410A-duty filter drier(s), shipped in cartons attached to the unit basepan. Remove the filter drier(s) and prepare to install in the liquid line(s) at the

evaporator coil. Do not remove connection fitting plugs until ready to connect and braze the filter drier into the liquid line position.

Table 8 – R-410A-duty Filter Drier(s)

Model-Size	Qty	Liquid Line OD	Desiccant Volume	Part Number Ref
CAS072	1	3/8-in	8 cu. in.	1179492
CAS091	1	1/2-in	16 cu. in.	1179538
CAS121	1	1/2-in	16 cu. in.	1179538
CAS151	1	5/8-in	16 cu. in.	1183798
CAS120	2	3/8-in	8 cu. in.	1179492
CAS150	2	1/2-in	16 cu. in.	1179538

Installation of liquid line moisture indicating sightglass in each circuit is recommended. Locate the sightglass(es) between the outlet of the filter drier and the TXV inlet.

Refer to Table 9 for recommendations on refrigeration specialties.

In some applications, depending on space and convenience requirements, it may be desirable to install 2 filter driers and sight glasses in a single circuit application. One filter drier and sight glass may be installed at A locations (see Fig. 6) or 2 filter driers and sight glasses may be installed at B locations (see Figs. 6 and 7).

Select the filter drier for maximum unit capacity and minimum pressure drop. Complete the refrigerant piping from the indoor unit to the outdoor unit before opening the liquid and suction lines at the outdoor unit.

Install Liquid Line Solenoid Valve —

It is recommended that a solenoid valve be placed in the main liquid line (see Figs. 6 and 7) between the condensing unit and the evaporator coil. Locate the solenoid valve at the outlet end of the liquid line, near the evaporator coil connections, with flow direction arrow pointed at the evaporator coil. Refer to Table 9. (A liquid line solenoid valve is required when the liquid line length exceeds 75 ft [23 m].) This valve prevents refrigerant migration (which causes oil dilution) to the compressor during the off cycle, at low outdoor ambient temperatures. Wire the solenoid in parallel with the compressor contactor coil (see Figs. 6 and 7). This means of electrical control is referred to as solenoid *drop* control.

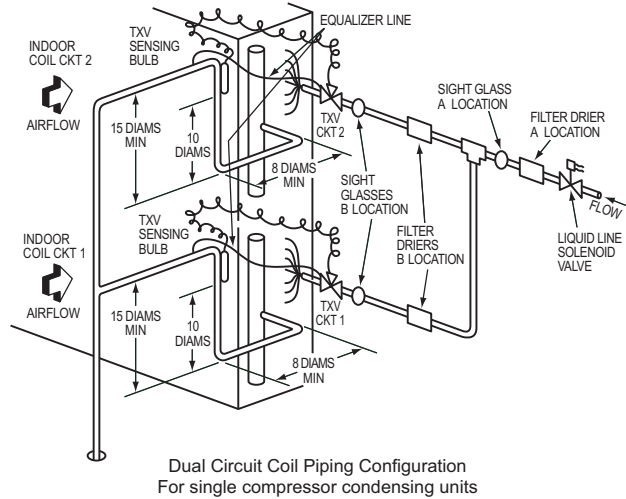
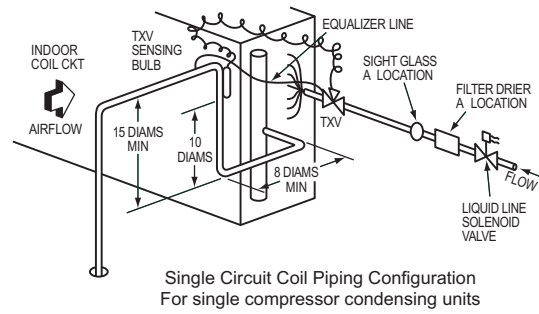

C10202

Fig. 6 - Location of Sight Glass(es) and Filter Driers Typical CAS072, 091, 121, 151 Systems

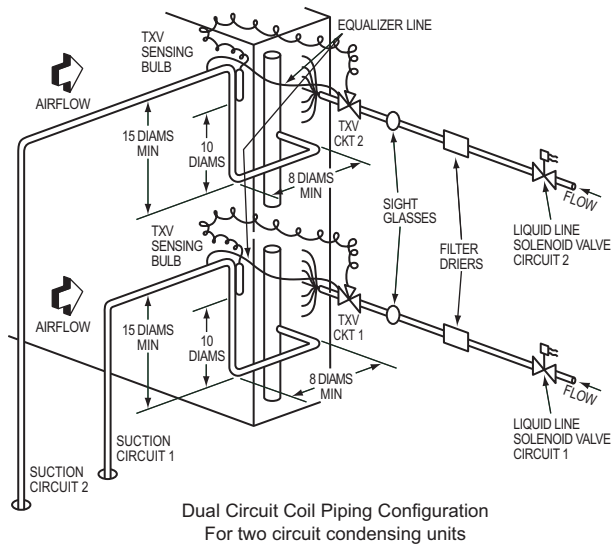

C10072

Fig. 7 - Location of Sight Glasses and Filter Driers Typical CAS120, 150 Systems

Table 9 – Refrigerant Specialties Part Numbers

LIQUID LINE SIZE (in.)	LIQUID LINE SOLENOID VALVE (LLSV)	LLSV COIL	SIGHT GLASS	FILTER DRIER
3/8	1179871	1179874	1179879	provided with unit see Table 8
1/2	1179872	1179874	1179878	
5/8	1179873	1179874	1179877	

CAS120, 150 units require TWO sets of parts.

Solenoid drop control wiring: Control the power to the liquid line solenoid through a Solenoid Valve Relay (SVR) in all units. Use part number 1178205 (field-supplied, installed). CAS072, 091, 121, 151 unit requires one SVR; CAS120, 150 unit requires two relays.

CAS120, 150 also requires a separate control power transformer for the liquid solenoid valve loads. Select transformer part number according to unit power supply.

Unit Power	Transformer Part #
208/230	1178027
460	1178077
575	1177852

Mount the SVR (and transformer TRAN3 when used) in unit control box. Connect per wiring schematic label on unit, see Fig. 25 thru Fig. 27.

Evaporator Capacity Control Liquid Line Solenoid Valve: Many older unit designs included automatic capacity controls that sensed changes in suction pressure and could increase or decrease compressor capacity automatically as the evaporator load changed. Control systems were used on these units that had the thermostat's second stage contacts control a capacity control liquid line solenoid valve to open or shutoff a portion of the evaporator surface without any direct connection to the compressor circuit.

This form of system capacity staging control is not possible with CAS models. If this installation is a retrofit for a unit that included automatic pressure-operated unloading, check the existing thermostat and liquid solenoid valve. When found, convert the evaporator second stage solenoid control into a drop-solenoid control. Use the two SVR relays and transformer as required on CAS120, 150 models (above); wire the SVRs and transformer per two solenoid valve systems as shown in Figs. 14 and 27.

Selecting an Accumulator —

Because all CAS models use scroll compressors, an accumulator is not required. If an accumulator is to be added, check the accumulator manufacturer's literature carefully for indication of its suitability for use with R-410A; look for minimum working pressure of 200 psig (1380 kPa). Select the accumulator first on the basis of its cataloged minimum capacity (tons) to ensure oil return from the accumulator, then on tube size or holding capacity.

Make Piping Connections —

Piping connections at the CAS unit are ball valves with stub tube extensions. Do not open the unit service valves until all interconnecting tube brazing has been completed.

The stub tube connections include 1/4-in SAE service fittings with Schrader valve cores (see Fig. 8). Before making any brazed connections to the unit service valves, remove both Schrader valve caps and cores and save for re-installation. Connect a source for nitrogen to one of these service fittings during tube brazing to prevent the

formation of copper oxides inside the tubes at brazed joints.

When connecting the field tubing to the CAS service valves, wrap the valves in wet rags to prevent overheating.

Pressure-test all joints from outdoor unit connections over to the evaporator coil, using nitrogen as pressure and with soap-and-bubbles.

When pressure-testing is completed, remove the nitrogen source at the outdoor unit service valves and re-install the two Schrader valve cores. Torque the cores to 2-3 in-lbs (23-34 N-cm).

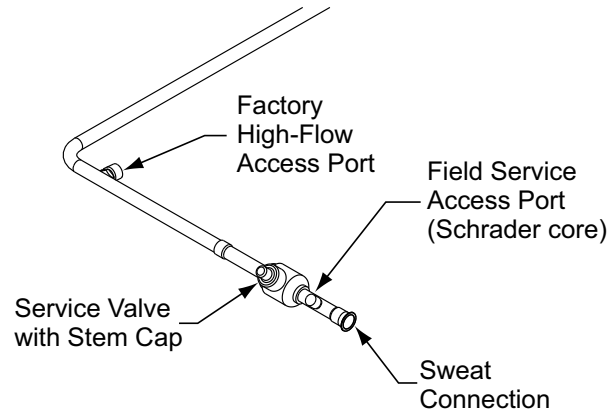

C150028

Fig. 8 - Typical Piping Connection Assembly

Evacuation/Dehydration —

Evacuate and dehydrate the connected refrigeration system(s) (excluding the CAS unit) to 500 microns using a two-stage vacuum pump attached to the service ports outside the CAS service valves, following description in GTAC II, Module 4, System Dehydration.

⚠ WARNING

UNIT OPERATION AND SAFETY HAZARD

Failure to follow this warning could cause personal injury, death and/or equipment damage.

R-410A refrigerant systems operate at higher pressure than standard R-22 systems. Do not use R-22 service equipment or components on R-410A refrigerant equipment.

This unit is designed for use with R-410A refrigerant. Do not use any other refrigerant in this system.

R-410A refrigerant is provided in pink (rose) colored cylinders. These cylinders are available with and without dip tubes; cylinders with dip tubes will have a label indicating this feature. For a cylinder with a dip tube, place the cylinder in the upright position (access valve at the top) when removing liquid refrigerant for charging. For a cylinder without a dip tube, invert the cylinder (access valve on the bottom) when removing liquid refrigerant.

Because R-410A refrigerant is a blend, it is strongly recommended that refrigerant always be removed from the cylinder as a liquid. Admit liquid refrigerant into the system in the discharge line. If adding refrigerant into the suction line, use a commercial metering/expansion device at the gauge manifold; remove liquid from the cylinder, pass it through the metering device at the gauge set and then pass it into the suction line as a vapor. Do not remove R-410A refrigerant from the cylinder as a vapor.

Preliminary Charge —

Before starting the unit, charge R-410A liquid refrigerant into the high side of each CAS circuit through the liquid service valve(s). The amount of refrigerant added must be at least 80% of the operating charge listed in Tables 5 or 6 for LINEAR line length LESS the factory charge quantity (if factory shipping charge has not been removed). See example below.

Allow high and low side pressures to equalize. If pressures do not equalize readily, charge R-410A vapor (using special service manifold with expansion device) into the suction line service port for the low side of system to assure charge in the evaporator. Refer to GTAC II, Module 5, Charging, Recover, Recycling, and Reclamation for liquid charging procedures.

Example:

CAS121

60-ft (18.3 m) linear line length

Equivalent line length 90-ft (27.4 m)

Liquid Lift: 20-ft (6.1 m)

Select line sizes from Table 5:

Liquid 1/2 in

Suction 1 1/8 in.

Charge 23.1 lbs (at 75-ft linear length)

80% of Operating Charge:

$0.80 \times 23.1 = 18.5$ lbs

Factory Shipping Charge: 9 lbs

Field-Charge quantity: $18.5 - 9.0 = 9.5$ lbs

For linear line lengths longer than 125 ft (38 m), contact your local ICP representative for system charge value.

Step 7 — Install Accessories

Accessories requiring modifications to unit wiring should be completed now. These accessories may include Winter Start controls and Low Ambient controls. Refer to the instructions shipped with the accessory.

Step 8 — Complete Electrical Connections

⚠ WARNING

ELECTRICAL SHOCK HAZARD

Failure to follow this warning could result in personal injury or death.

Do not use gas piping as an electrical ground. Unit cabinet must have an uninterrupted, unbroken electrical ground to minimize the possibility of personal injury if an electrical fault should occur. This ground may consist of electrical wire connected to unit ground lug in control compartment, or conduit approved for electrical ground when installed in accordance with NEC (National Electrical Code); ANSI/NFPA 70, latest edition (in Canada, Canadian Electrical Code CSA [Canadian Standards Association] C22.1), and local electrical codes.

NOTE: Check all factory and field electrical connections for tightness. Field-supplied wiring shall conform with the limitations of 63°F (33°C) rise.

Field Power Supply —

Field power wires are connected to the unit at line-side pressure lugs on compressor contactor C and TB1 (see wiring diagram label for control box component arrangement) or at factory-installed option non-fused disconnect switch. Max wire size is #4 AWG (copper only).

NOTE: TEST LEADS - Unit may be equipped with short leads (pigtailed) on the field line connection points on contactor C or optional disconnect switch. These leads are for factory run-test purposes only; remove and discard before connecting field power wires to unit connection points. Make field power connections directly to line connection pressure lugs only.

⚠ WARNING

FIRE HAZARD

Failure to follow this warning could cause in personal injury, death and/or equipment damage.

Do not connect aluminum wire between disconnect switch and condensing unit. Use only copper wire. (See Fig. 9.)

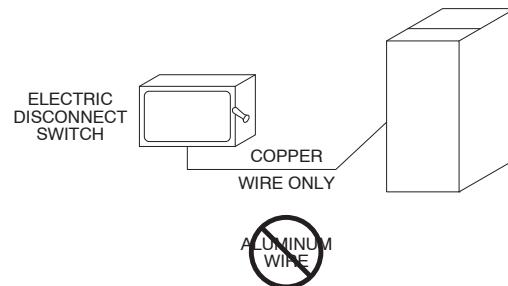

Fig. 9 - Disconnect Switch and Unit

A93033

Units Without Factory-Installed Non-Fused Disconnect —

When installing units, provide a disconnect switch per NEC (National Electrical Code) of adequate size. Disconnect sizing data is provided on the unit informative plate. Locate on unit cabinet or within sight of the unit per national or local codes. Do not cover unit informative plate if mounting the disconnect on the unit cabinet.

Units with Factory-Installed Non-Fused Disconnect —

The factory-installed option disconnect switch is located in a weatherproof enclosure located under the main control box. The manual switch handle is accessible through an opening in the access panel.

All Units —

All field wiring must comply with NEC and all local codes. Size wire based on MCA (Minimum Circuit Amps) on the unit informative plate. See Fig. 10 for power wiring connections to the unit contactor and terminal block and equipment ground.

Provide a ground-fault and short-circuit over-current protection device (fuse or breaker) per NEC Article 440 (or local codes). Refer to unit informative data plate for MOCP (Maximum Over-current Protection) device size.

All units except 208/230-v units are factory wired for the voltage shown on the nameplate. *If the 208/230-v unit is to be connected to a 208-v power supply, the control transformer must be rewired by moving the black wire with the 1/4-in. female spade connector from the 230-v connection and moving it to the 208-v 1/4-in. male terminal on the primary side of the transformer.* Refer to unit label diagram for line-side information.

Affix the crankcase heater warning sticker to the unit disconnect switch.

Units Without Disconnect Option

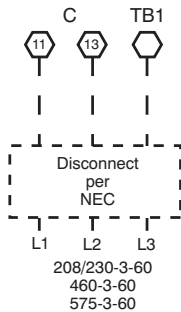

Units With Disconnect Option

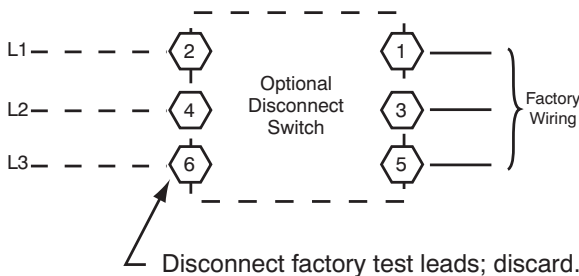

Fig. 10 - Power Wiring Connections

C10204

Convenience Outlets —

⚠ WARNING

ELECTRICAL OPERATION HAZARD

Failure to follow this warning could result in personal injury or death.

Units with convenience outlet circuits may use multiple disconnects. Check convenience outlet for power status before opening unit for service. Locate its disconnect switch, if appropriate, and open it. Tag-out this switch, if necessary.

Non-powered convenience outlets are offered on CAS models that provide a 125-volt GFCI (ground-fault circuit-interrupter) duplex receptacle rated at 15-A behind a hinged waterproof access cover, located on the end panel of the unit. See Fig. 11.

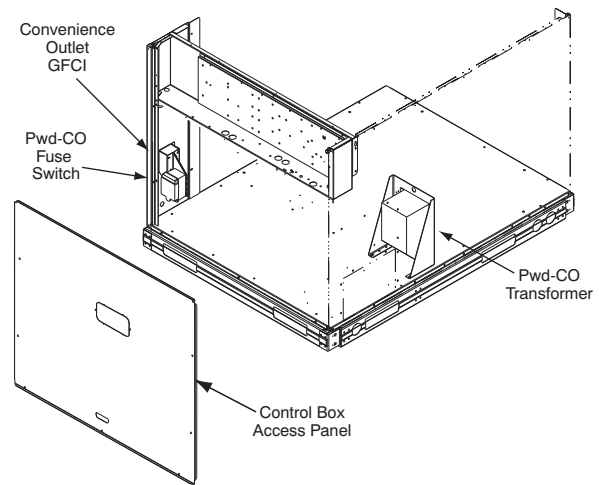

Fig. 11 - Convenience Outlet Location

C10936

Non-powered type: This type requires the field installation of a general-purpose 125-volt 15-A circuit powered from a source elsewhere in the building. Observe national and local codes when selecting wire size, fuse or breaker requirements and disconnect switch size and location. Route 125-v power supply conductors into the bottom of the utility box containing the duplex receptacle.

Maximum continuous current for this type of convenience outlet (non-unit powered) must not exceed 8 Amps.

⚠ WARNING

ELECTRICAL OPERATION HAZARD

Failure to follow this warning could result in personal injury or death.

Using unit-mounted convenience outlets: Units with unit-mounted convenience outlet circuits will often require that two disconnects be opened to de-energize all power to the unit. Treat all units as electrically energized until the convenience outlet power is also checked and de-energization is confirmed. Observe National Electrical Code Article 210, Branch Circuits, for use of convenience outlets.

Installing Weatherproof Cover: A weatherproof while in use cover for the factory installed convenience outlets is now required by UL standards. This cover cannot be factory mounted due its depth; it must be installed at unit installation. For shipment, the convenience outlet is covered with a blank cover plate.

The weatherproof cover kit is shipped in the unit's control box. The kit includes the hinged cover, a backing plate and gasket.

DISCONNECT ALL POWER TO UNIT AND CONVENIENCE OUTLET.

Remove the blank cover plate at the convenience outlet; discard the blank cover.

Loosen the two screws at the GFCI duplex outlet, until approximately 1/2.in (13 mm) under screw heads are exposed. Press the gasket over the screw heads. Slip the backing plate over the screw heads at the keyhole slots and align with the gasket; tighten the two screws until snug (do not overtighten).

Mount the weatherproof cover to the backing plate as shown in Fig. 12. Remove two slot fillers in the bottom of the cover to permit service tool cords to exit the cover. Check for full closing and latching.-

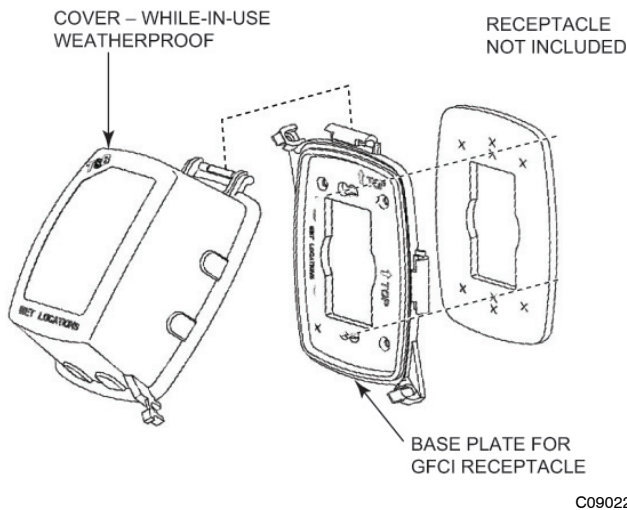

Fig. 12 - Weatherproof Cover Installation

All Units —

Voltage to compressor terminals during operation must be within voltage range indicated on unit nameplate. See Tables 10 and 11. On 3-phase units, voltages between phases must be balanced within 2% and the current within 10%. Use the formula shown in the legend for Tables 10 and 11, Note 4 (see page 22) to determine the percent of voltage imbalance. Operation on improper line voltage or excessive phase imbalance constitutes abuse and may cause damage to electrical components. Such operation would invalidate any applicable warranty.

Field Control Wiring —

CAS unit control voltage is 24 v. See Figs. 25 - 27 for typical field control connections and the unit's label diagram for field-supplied wiring details. Route control wires to the CAS unit through the opening in unit's end panel to the connections terminal board in the unit's control box.

Remainder of the system controls connection will vary according to the specific construction details of the indoor section (air handler or packaged fan coil). Fig. 13 (CAS072, 091, 121, 151) and Fig. 14 (CAS120, 150) depict typical connections to a FAS fan coil unit. Plan for field connections carefully and install control wiring correctly per the project plan. Additional components and supplemental transformer accessory may be required.

The CAS unit requires an external temperature control device. This device can be a thermostat (field-supplied) or a thermostat emulation device provided as part of a third-party Building Management System.

Thermostat —

Install an approved accessory thermostat according to installation instructions included with the accessory. Locate the thermostat accessory on a solid wall in the conditioned space to sense average temperature in accordance with the thermostat installation instructions.

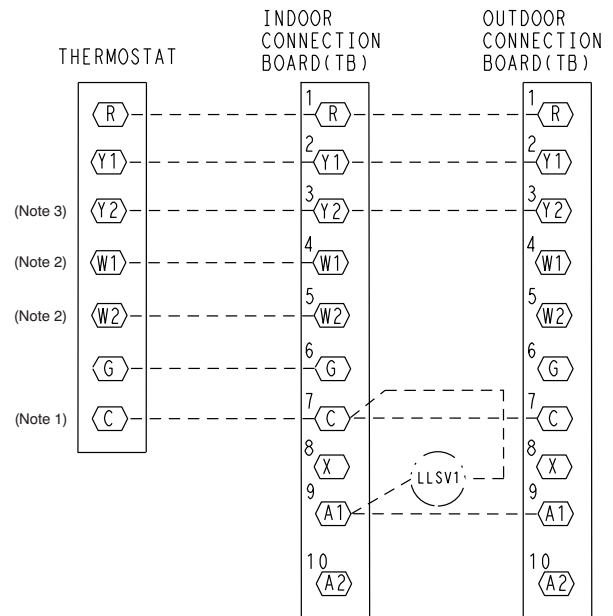

- Note 1: Connect only if thermostat requires 24-vac power source.
- Note 2: Connect W1 and W2 if supplemental heaters are installed
- Note 3: Y2 connection for Single Circuit/2-Stage units only
- - - Field Wiring

C150413

Fig. 13 - Typical Remote Thermostat Connections — CAS072, 091, 121, 151

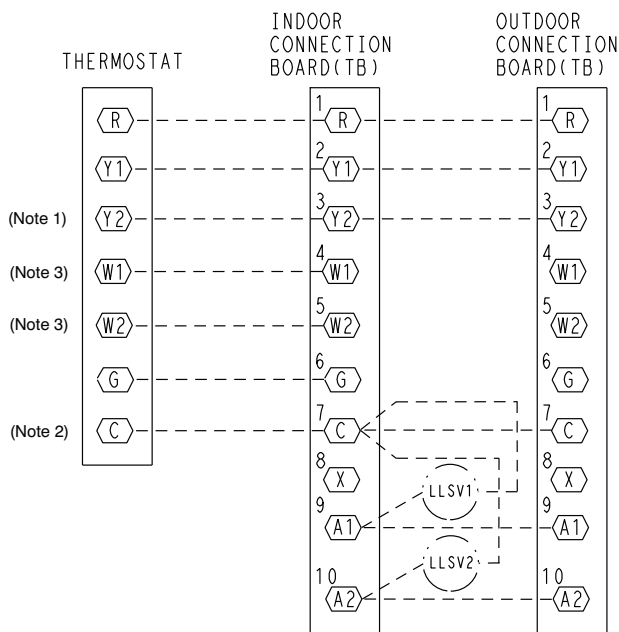

Note 1: Typical multi-function marking. Follow manufacturer's configuration instructions to select Y2.
 Note 2: Connect only if thermostat requires 24-vac power source.
 Note 3: Connect W1 and W2 if supplemental heaters are installed
 - - - Field Wiring

C10078

Fig. 14 - Typical Remote Thermostat Connections — CAS120, 150

The CAS072, 091, 121, 151*A/B unit is a single-stage cooling unit. If no economizer function is required, select a single-stage cooling thermostat. If an integrated economizer function is required, select a two-stage cooling thermostat.

CAS072*G/H is a single circuit, two-stage cooling unit. Select a two-stage cooling thermostat.

The CAS120, 150*D/E is a dual-circuit, two-stage cooling unit. Select a two-stage cooling thermostat.

Select a thermostat cable or equivalent single leads of different colors with minimum of four leads for CAS072, 091, 121, 151 or five leads for CAS072*G/H, CAS120, and CAS150 units. Check the thermostat installation instructions for additional features which might require additional conductors in the cable.

For wire runs up to 50 ft. (15 m), use no. 18 AWG (American Wire Gage) insulated wire (35°C minimum). For 50 to 75 ft. (15 to 23 m), use no. 16 AWG insulated wire (35°C minimum). For over 75 ft. (23 m), use no. 14 AWG insulated wire (35°C minimum). All wire sizes larger than no. 18 AWG cannot be directly connected to the thermostat and will require a junction box and splice at the thermostat.

If the unit will be operating at 208-3-60 power, remove the black wire (BLK) from the transformer primary connection labelled "230" and move it to the connection labelled "208". See Fig. 15.

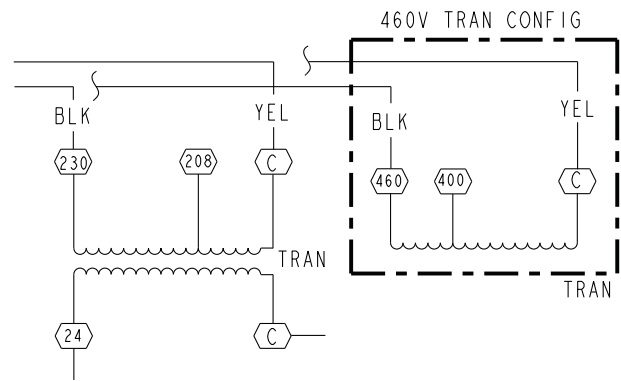

C10079

Fig. 15 - Control Transformer Wiring

External Devices —

The CAS control transformers provide 24-v NEC Class 2 power sources to energize external control devices. These devices will include the indoor fan motor contactor (or control relay). These devices may also include liquid line solenoid valve (two on CAS120, 150 model), economizer control relay, supplemental electric heater contactors or control relays and other devices selected by system designer.

Control transformer TRAN1 provides control power through terminal R to C on the field connection terminal strip TB for supply fan motor interlock. This source may also be used to energize economizer control relay and electric heater contactors or relays. Maximum available power is 20 va. Check concurrent loadings by external control devices. If the maximum concurrent loading exceeds 20 va, purchase and install the accessory Transformer-Relay package (available for 208/230 and 460-v units).

CAS120, 150 Only: Control transformer TRAN3 provides control power through terminals A1 (9) and A2 (10) to C for liquid line solenoids. Maximum available power is 75 va. These outputs are switched ON/OFF by the Solenoid Valve Relays.

Step 9 — Wind Baffles for Low Ambient Control

Models CAS072*B/H, CAS091*B, CAS1218B, CASS151*B and CAS120*E, CAS150* E include the factory installed 32LT Motormaster Low Ambient Control.

Units with 32LT Motormaster control require the addition of wind baffles to ensure full range low ambient operation. Material data and dimensions for wind baffles are included in the Appendix C section, Low Ambient Control, starting on page 46. Fabricate the wind baffles and mount per instructions.

Table 10 – Electrical Data — CAS072 - 151 60 Hz Units

WITHOUT POWERED CONVENIENCE OUTLET											
UNIT	V-Ph-Hz	VOLTAGE RANGE [‡]		COMPRESSOR 1		OFM (ea)		POWER SUPPLY		DISCONNECT SIZE	
		MIN	MAX	RLA	LRA	QTY	FLA	MCA	Fuse or HACR Brkr	FLA	LRA
CAS072*A/B Units produced on or after 02/09/2015	208/230-3-60	187	253	19.6	136	2	1.5	28/28	45/45	26/26	142/142
	460-3-60	414	506	8.2	66	2	0.8	12	20	11	70
	575-3-60	518	633	6.6	55	2	0.7	10	15	9	59
CAS072*A/B Units produced on or prior to 02/08/2015	208/230-3-60	187	253	19.0	123	2	1.5	26.8/26.8	45/45	25/25	129/129
	460-3-60	414	506	9.7	62	2	0.8	13.7	20	13	66
	575-3-60	518	633	7.4	50	2	0.7	10.4	15	10	54
CAS072*G/H	208/230-3-60	187	253	17.5	136	2	1.5	25/25	30/30	24/24	142/142
	460-3-60	414	506	8.4	66	2	0.8	13	20	12	70
	575-3-60	518	633	6.6	55	2	0.7	10	15	9	59
CAS091	208/230-3-60	187	253	25.0	164	2	1.5	35/35	50/50	32/32	170/170
	460-3-60	414	506	12.2	100	2	0.8	17	25	16	104
	575-3-60	518	633	9.0	78	2	0.7	13	20	12	82
CAS121	208/230-3-60	187	253	30.1	225	2	1.5	41/41	60/60	38/38	231/231
	460-3-60	414	506	16.7	114	2	0.8	23	30	21	118
	575-3-60	518	633	12.2	80	2	0.7	17	25	16	84
CAS151	208/230-3-60	187	253	48.1	245	2	1.5	64/64	80/80	59/59	251/251
	460-3-60	414	506	18.6	125	2	0.8	25	30	23	129
	575-3-60	518	633	14.7	100	2	0.7	20	30	19	104

NOTE: See “Legend and Notes for Tables 10 and 11” on page 22.

Table 11 – Electrical Data — CAS120 - 150 60 Hz Units

WITHOUT POWERED CONVENIENCE OUTLET													
UNIT	V-Ph-Hz	VOLTAGE RANGE [‡]		COMPRESSOR 1		COMPRESSOR 2		OFM (ea)		POWER SUPPLY		DISCONNECT SIZE	
		MIN	MAX	RLA	LRA	RLA	LRA	QTY	FLA	MCA	Fuse or HACR Brkr	LRA	RLA
CAS120	208/230-3-60	187	253	15.9	110	15.9	110	2	1.5	39/39	50/50	40/40	226/226
	460-3-60	414	506	7.7	52	7.7	52	2	0.8	19	25	20	108
	575-3-60	518	633	5.7	39	5.7	39	2	0.7	15	20	15	82
CAS150	208/230-3-60	187	253	22.4	149	22.4	149	2	1.5	54/54	60/60	55/55	304/304
	460-3-60	414	506	10.6	75	10.6	75	2	0.8	26	30	26	154
	575-3-60	518	633	7.7	54	7.7	54	2	0.7	19	25	19	112

NOTE: See “Legend and Notes for Tables 10 and 11” on page 22.

Legend and Notes for Tables 10 and 11

LEGEND:

- FLA – Full Load Amps
- LRA – Locked Rotor Amps
- MOCP – Maximum Over Current Protection
- NEC – National Electrical Code
- RLA – Rated Load Amps



‡ Units are suitable for use on electrical systems where voltage supplied to the unit terminals is not below or above the listed limits.

NOTES:

1. The MCA and Fuse values are calculated in accordance with The NEC, Article 440.
2. Motor RLA and LRA values are established in accordance with Underwriters' Laboratories (UL), Standard 1995.
3. The 575-v units are UL, Canada-listed only.
4. **Unbalanced 3-Phase Supply Voltage**
Never operate a motor where a phase imbalance in supply voltage is greater than 2%. Use the following formula to determine the percentage of voltage imbalance.

Example: Supply voltage is 230-3-60

$$\% \text{ Voltage Imbalance} = 100 \times \frac{\text{max voltage deviation from average voltage}}{\text{average voltage}}$$



- AB = 224 v
- BC = 231 v
- AC = 226 v

$$\begin{aligned} \text{Average Voltage} &= \frac{(224 + 231 + 226)}{3} = \frac{681}{3} \\ &= 227 \end{aligned}$$

Determine maximum deviation from average voltage.

- (AB) 227 – 224 = 3 v
- (BC) 231 – 227 = 4 v
- (AC) 227 – 226 = 1 v

Maximum deviation is 4 v.

Determine percent of voltage imbalance.

$$\begin{aligned} \% \text{ Voltage Imbalance} &= 100 \times \frac{4}{227} \\ &= 1.76\% \end{aligned}$$

This amount of phase imbalance is satisfactory as it is below the maximum allowable 2%.

IMPORTANT: If the supply voltage phase imbalance is more than 2%, contact your local electric utility company immediately.

PRE-START-UP

IMPORTANT: Before beginning Pre-Start-Up or Start-Up, review Start-Up Checklist at the back of this book. The Checklist assures proper start-up of a unit and provides a record of unit condition, application requirements, system information, and operation at initial start-up.

⚠ CAUTION

UNIT DAMAGE HAZARD

Failure to follow this caution may result in equipment damage.

Do not attempt to start the condensing unit, even momentarily, until the following steps have been completed. Compressor damage may result.

System Check

1. The electrical power source must agree with the unit's nameplate rating.
2. Check all air handler(s) and other equipment auxiliary components. Consult the manufacturer's instructions regarding any other equipment connected to the condensing unit. If the unit has field-installed accessories, be sure all are properly installed and correctly wired. If used, the airflow switch must be properly installed.
3. Check tightness of all electrical connections.
4. Be sure liquid line and low side of the system are properly leak checked and dehydrated.
5. Be sure the unit is properly charged. See "Preliminary Charge", below.
6. Open the liquid line and suction line service valves.
7. The crankcase heater must be firmly attached to the compressor crankcase. Be sure the crankcase is warm (heater must be on for 24 hours before starting compressor).

Turn On Crankcase Heater —

Turn on the crankcase heater for 24 hours before starting the unit to be sure all the refrigerant is out of the oil. To energize the crankcase heater, proceed as follows:

1. Set the space thermostat set point above the space temperature so there is no demand for cooling.
2. Close the field disconnect.

Preliminary Charge —

Before starting the unit, charge liquid refrigerant into the high side of the system through the liquid service valve. The amount of refrigerant added must be at least 80% of the operating charge listed in the Physical Data table (Tables 1A through 2B, pages 6 through 9). Allow high and low side pressures to equalize before starting compressor. If pressures do not equalize readily, charge vapor on low side of system to assure charge in the evaporator. Refer to GTAC II, Module 5, Charging, Recover, Recycling, and Reclamation for liquid charging procedures.

⚠ CAUTION

UNIT DAMAGE HAZARD

Failure to follow this caution may result in equipment damage.

Prior to starting compressor, a preliminary charge of refrigerant must be added to avoid possible compressor damage.

START-UP

CAS Units: The compressor crankcase heater must be on for 24 hours before start-up. After the heater has been on for 24 hours, the unit can be started. If no time elapsed since the preliminary charge step was completed, it is unnecessary to wait the 24-hour period.

Preliminary Checks

1. Check that electric power supply agrees with unit nameplate data.
2. Verify that the compressor crankcase heater is securely in place.
3. Check that the compressor crankcase heater has been on at least 24 hours.
4. Recheck for leaks using the procedure outlined in the Pre-Start-Up section, Leak Test and Dehydration. If any leaks are detected, repair as required. Evacuate and dehydrate as described in the Leak Test and Dehydration section.
5. Ensure that the preliminary charge has been added as described in the Pre-Start-Up section, Preliminary Charge.
6. All internal wiring connections must be tight, and all barriers and covers must be in place.

NOTE: The CAS units are factory charged with the required amount of oil. If recharging is required, use Emkarate RL 32-3MAF for the CAS units.

Compressor Rotation —

On 3-phase units with scroll compressors, it is important to be certain that the compressor is rotating in the proper direction. CAS units are equipped with a Comfort Alert Diagnostic Module (CADM). Alert Code 7 indicates reverse power phasing.

To correct phase order:

1. Turn off power to the unit, tag disconnect.
2. Reverse any two of the unit power leads.
3. Reapply power to the compressor, verify correct pressures.

To verify the compressor is rotating in the proper direction:

1. Connect service gages to the suction and liquid pressure fittings.
2. Energize the compressor.
3. The suction pressure should drop and the liquid pressure should rise, as is normal on any start-up.

Compressor Overload —

This overload interrupts power to the compressor when either the current or internal motor winding temperature becomes excessive, and automatically resets when the internal temperature drops to a safe level. This overload may require up to 60 minutes (or longer) to reset. If the internal overload is suspected of being open, disconnect the electrical power to the unit and check the circuit through the overload with an ohmmeter or continuity tester.

Advanced Scroll Temperature Protection (ASTP) —

A label located above the terminal box identifies Copeland Scroll compressor models that contain this technology. See Fig. 16. Advanced Scroll Temperature Protection (ASTP) is a form of internal discharge temperature protection, that unloads the scroll compressor when the internal temperature reaches approximately 149°C (300°F). At this temperature, an internal bi-metal disk valve opens and causes the scroll elements to separate, which stops compression. Suction and discharge pressures balance while the motor continues to run. The longer the compressor runs unloaded, the longer it must cool before the bi-metal disk resets. See Fig. 17.

To manually reset ASTP, the compressor should be stopped and allowed to cool. If the compressor is not stopped, the motor will run until the motor protector trips, which occurs up to 90 minutes later. Advanced Scroll Temperature Protection will reset automatically before the motor protector resets, which may take up to 2 hours.



C10080

Fig. 16 - Advanced Scroll Temperature Protection Label

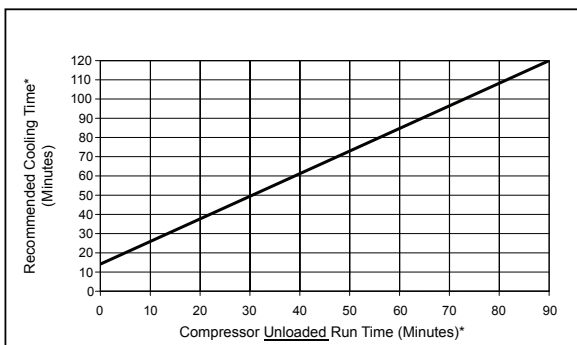

*Times are approximate.

NOTE: Various factors, including high humidity, high ambient temperature, and the presence of a sound blanket will increase cool-down times.

C10081

Fig. 17 - Recommended Minimum Cool-Down Time After Compressor is Stopped

Start Unit

Set the space thermostat to a set point above space temperature so that there is no demand for cooling. Close the CAS disconnect switch. Only the crankcase heater will be energized.

Reset the space thermostat below ambient so that a call for cooling is ensured.

⚠ CAUTION

UNIT DAMAGE HAZARD

Failure to follow this caution may result in equipment damage.

Never charge liquid into the low-pressure side of system. Do not overcharge. During charging or removal of refrigerant, be sure indoor-fan system is operating. Ensure both outdoor fan motors are running; bypass any Motormaster function.

Adjust Refrigerant Charge —

Refer to Cooling Charging Charts, Fig. 18 through Fig. 24. For applications with line lengths greater than 125 ft (38 m), contact your local service representative. Vary refrigerant until the conditions of the chart are met. Note that the charging charts are different from the type normally used. The charts are based on charging the units to the correct subcooling for the various operating conditions. Accurate pressure gage and temperature sensing device are required. Connect the pressure gage to the service port on the liquid line service valve. Mount the temperature sensing device on the liquid line close to the liquid line service valve, and insulate it so that outdoor ambient temperature does not affect the reading. Indoor airflow must be within the unit's normal operating range. Operate the unit for a minimum of 15 minutes. Ensure that pressure and temperature readings have stabilized. Plot the liquid pressure and temperature on chart and add or reduce the charge to meet the curve. Adjust the charge to conform with the charging chart, using the liquid pressure and temperature to read the chart.

Using plotted operating point:

If plotted operating condition is -	Adjust charge by -
BELOW the curve	REDUCE charge
ABOVE the curve	ADD charge

Final Checks —

Ensure that all safety controls are operating, control panel covers are on, and the service panels are in place.

6 Ton Charging Chart R410a Refrigerant

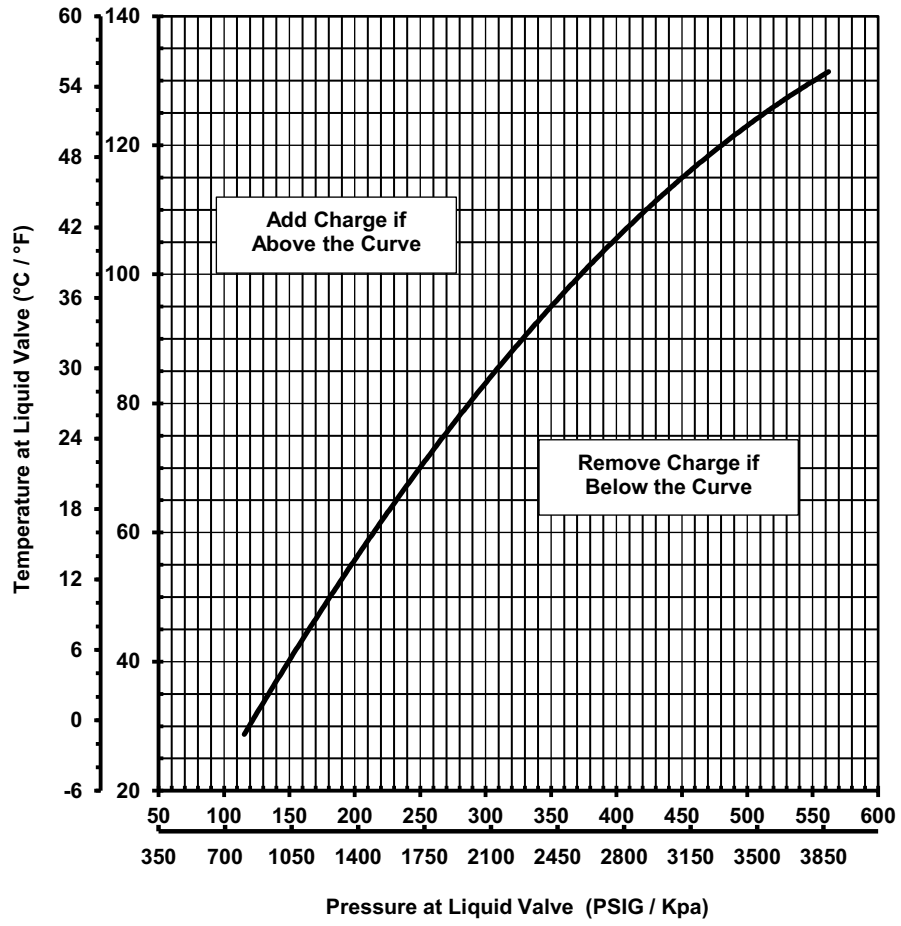

38AU501045 C

Fig. 18 - CAS072*A/B Charging Chart (RTPF)

C150414

7.5 Ton Charging Chart R410a Refrigerant

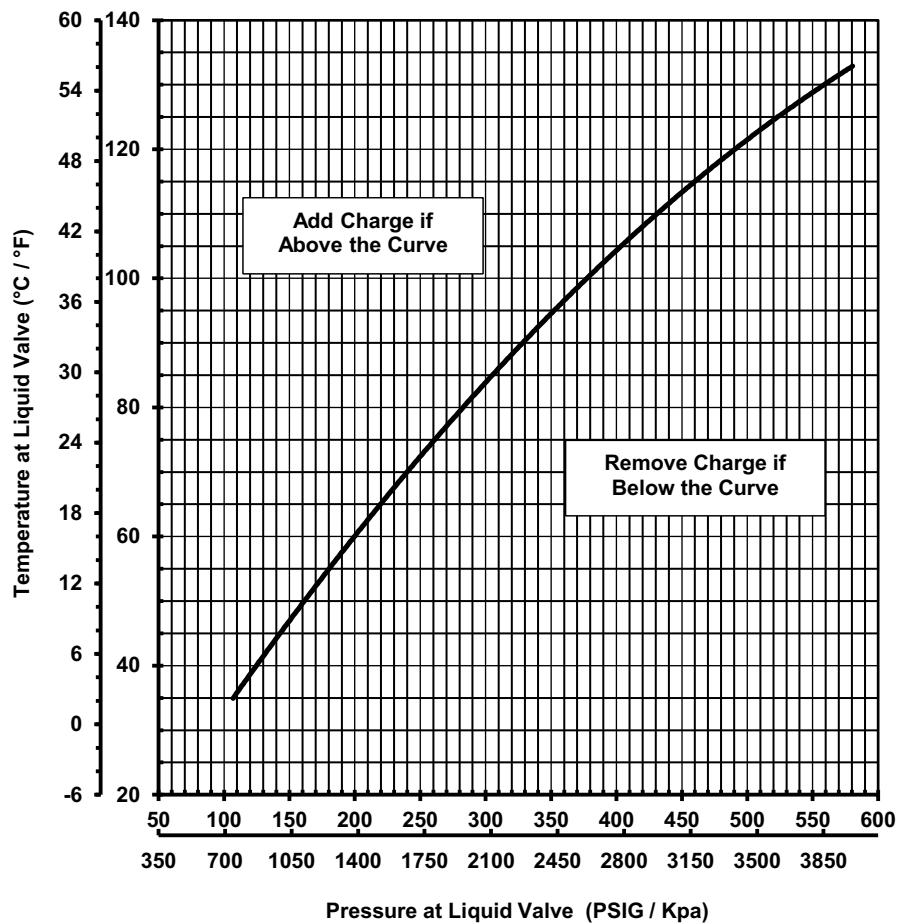

38AU501046 C

Fig. 19 - CAS091*A/B Charging Chart (RTPF)

C150415

10 Ton Charging Chart R410a Refrigerant

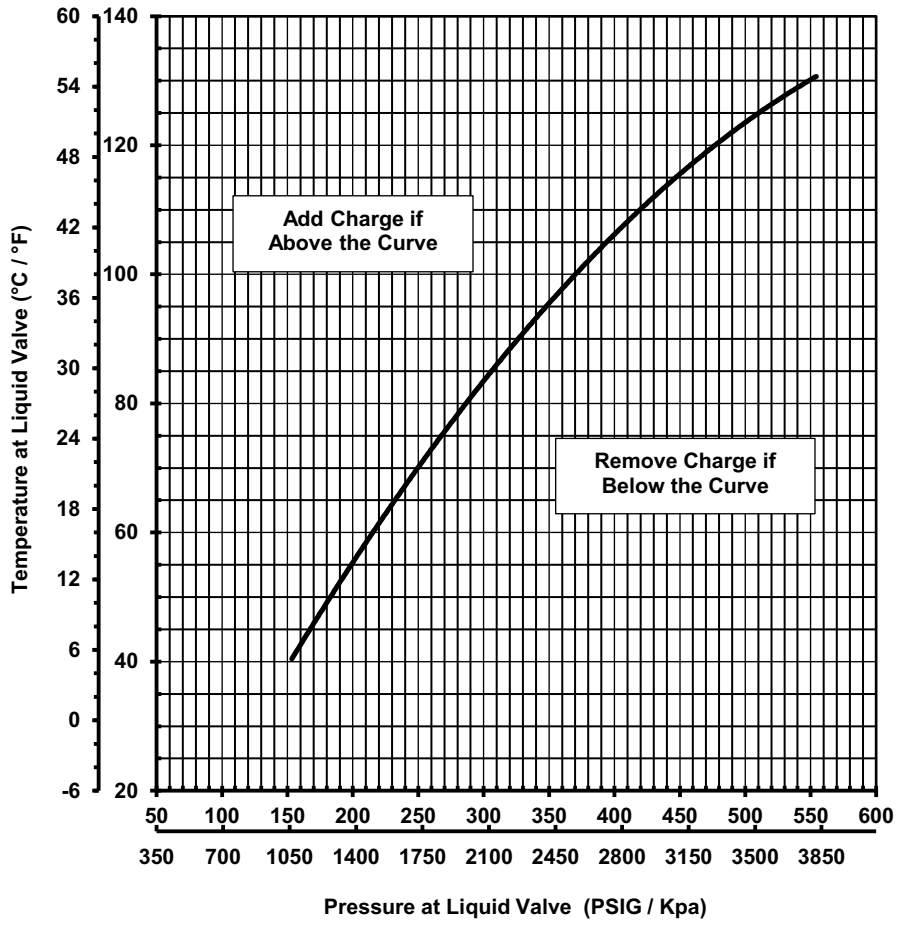
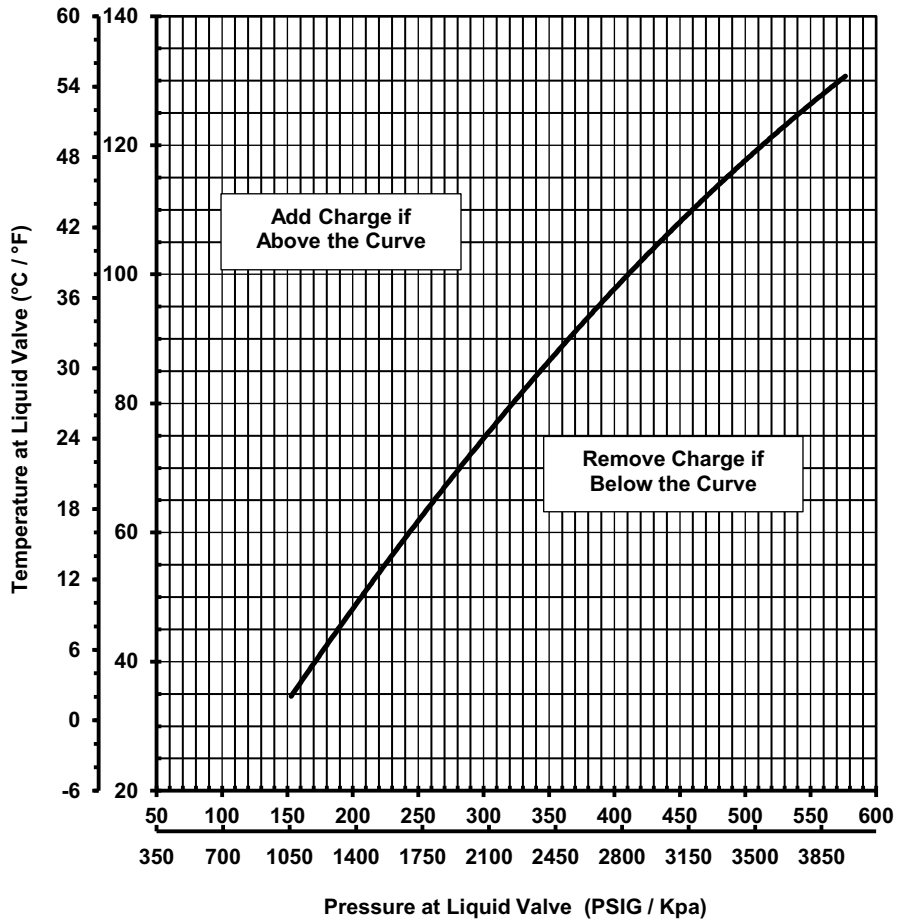

Fig. 20 - CAS121*A/B Charging Chart (RTPF)

C150416

12.5 Ton Charging Chart R410a Refrigerant



38AU501048 C

Fig. 21 - CAS151*A/B Charging Chart (RTPF)

C150417

**6 TON DUAL STAGE CHARGING CHART PURON
(COMPRESSOR FULL LOAD, ALL CONDENSER FANS OPERATING)**

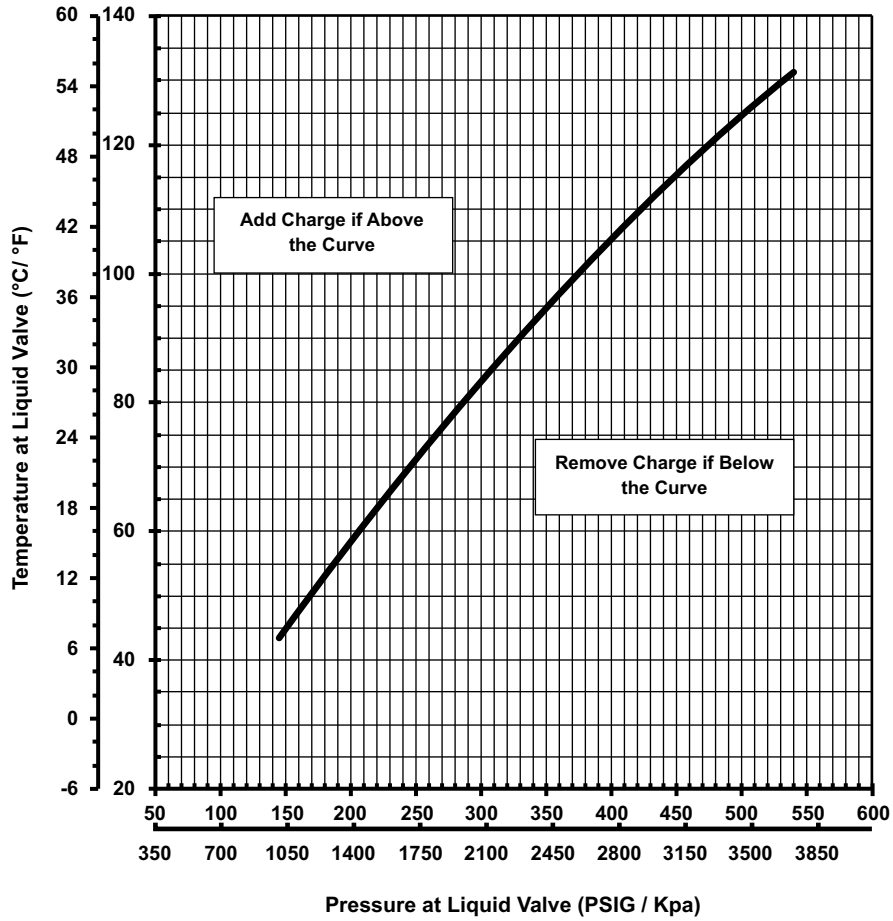

PN: 38AU000484 REV -

Fig. 22 - CAS072*G/H Charging Chart (RTPF)

C150338

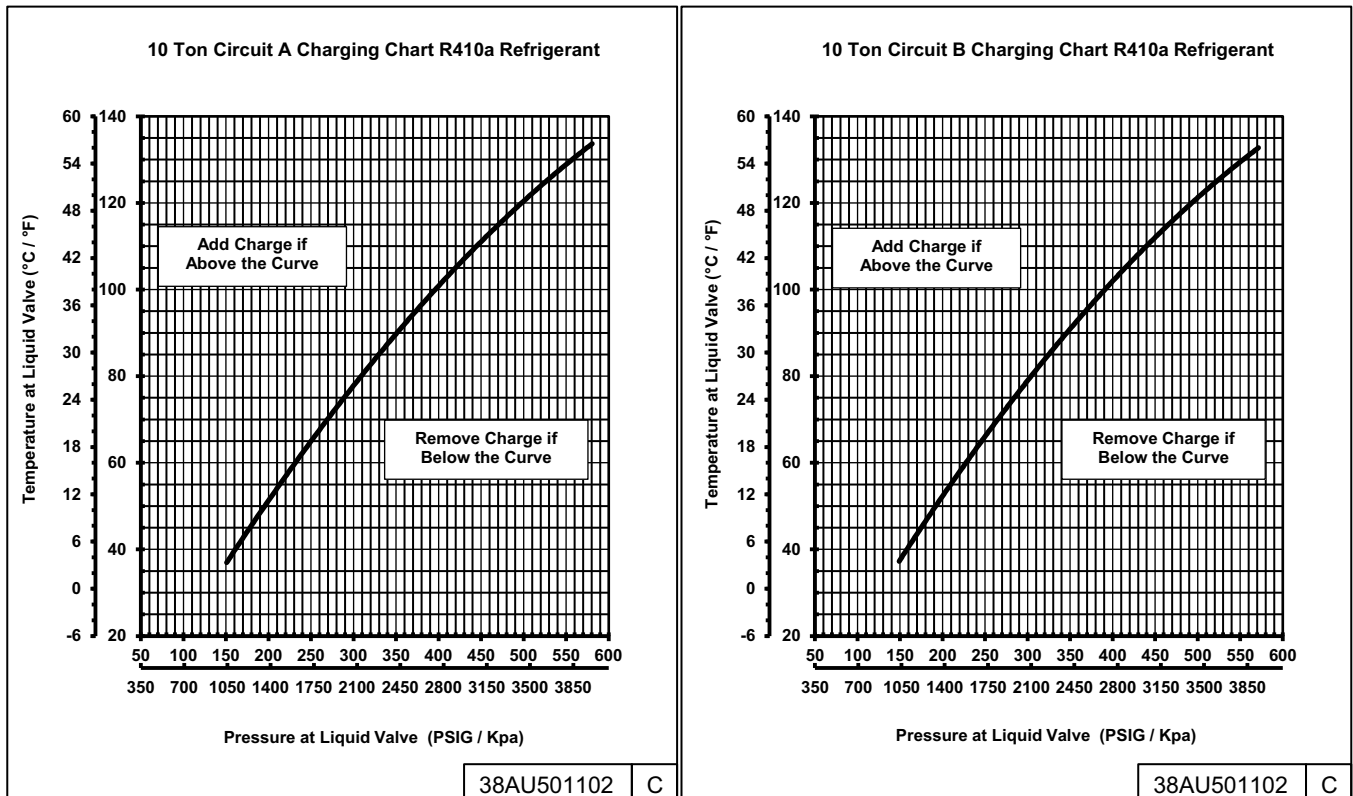

C150418

Fig. 23 - CAS120*D/E Charging Chart (RTPF)

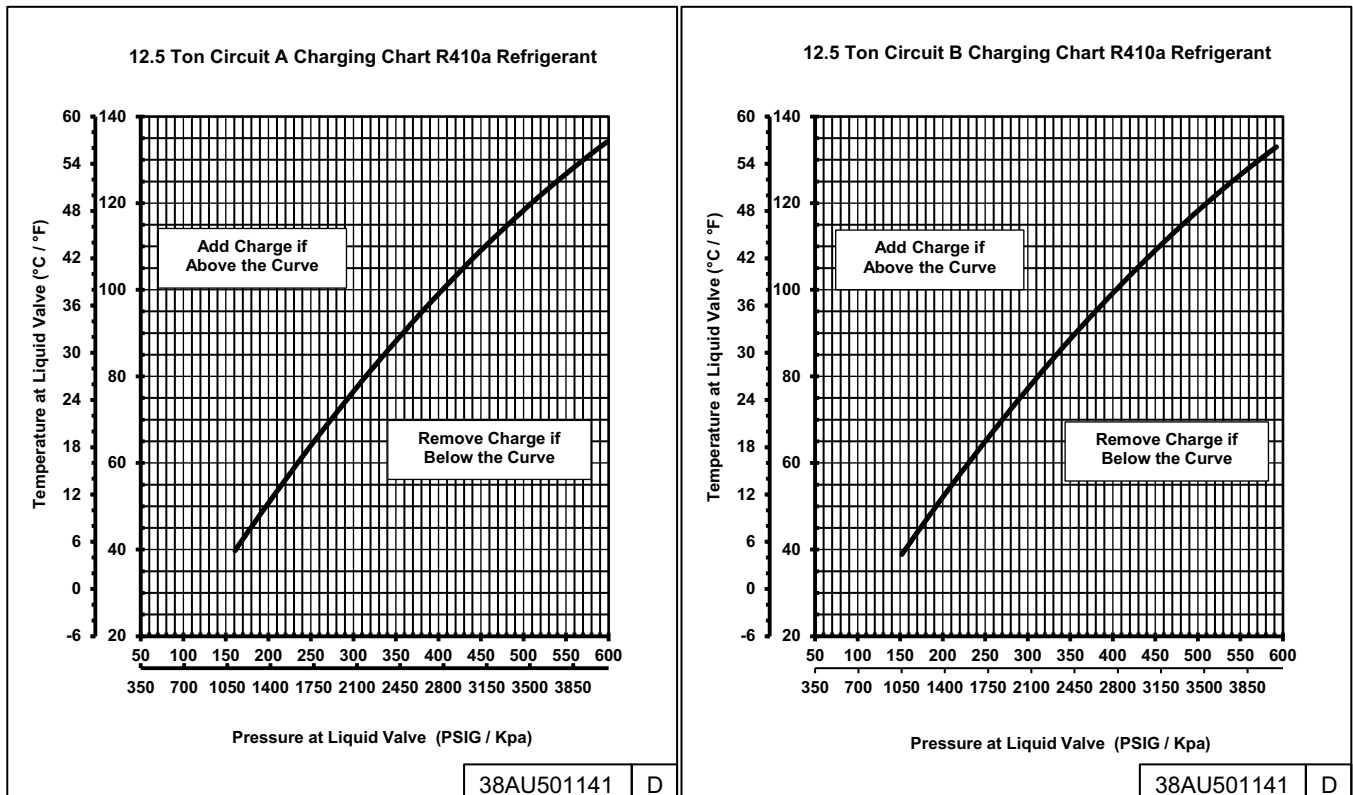

C150419

Fig. 24 - CAS150*D/E Charging Chart (RTPF)

SCHEMATIC
6-10T 208/230V SNGL

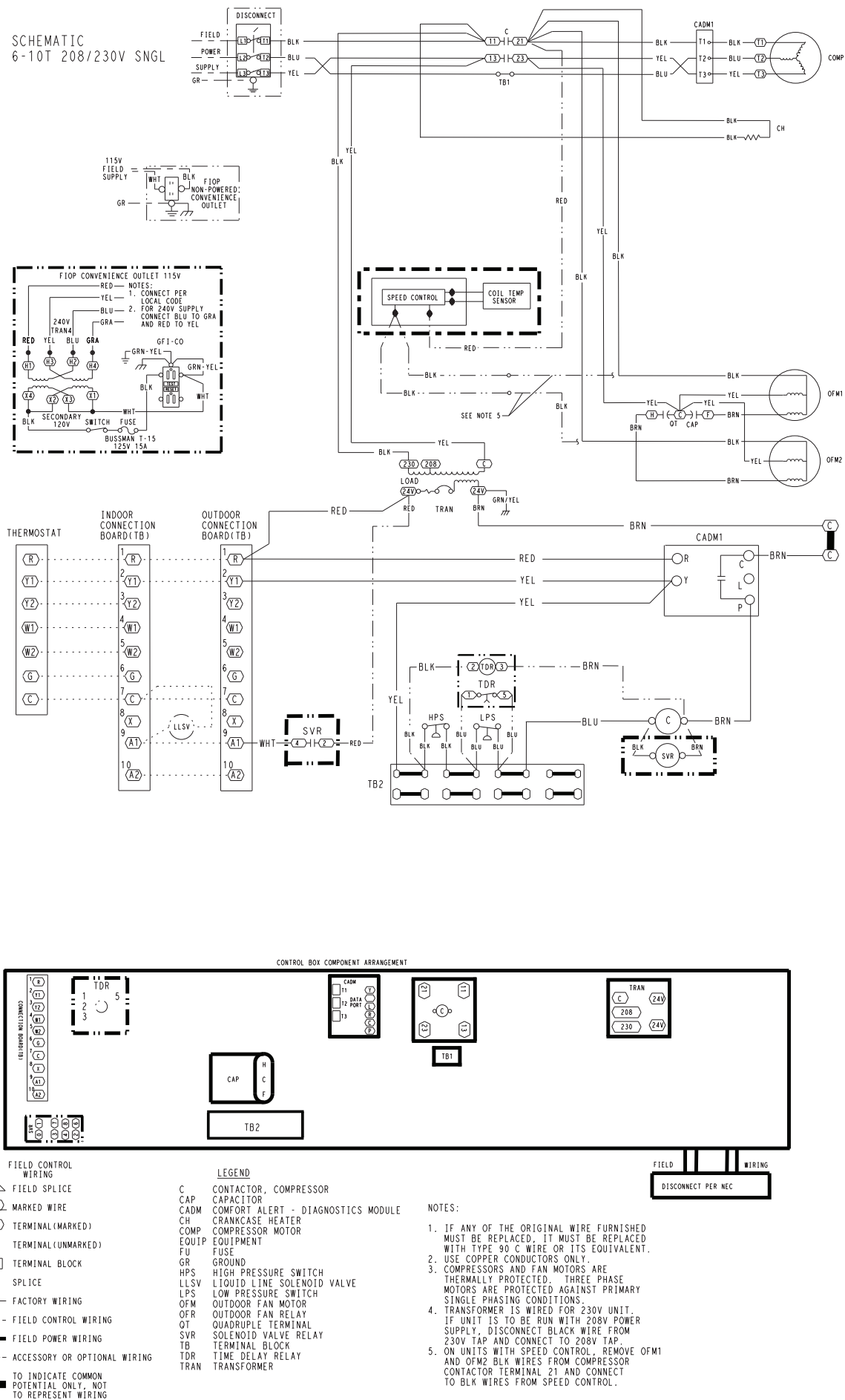
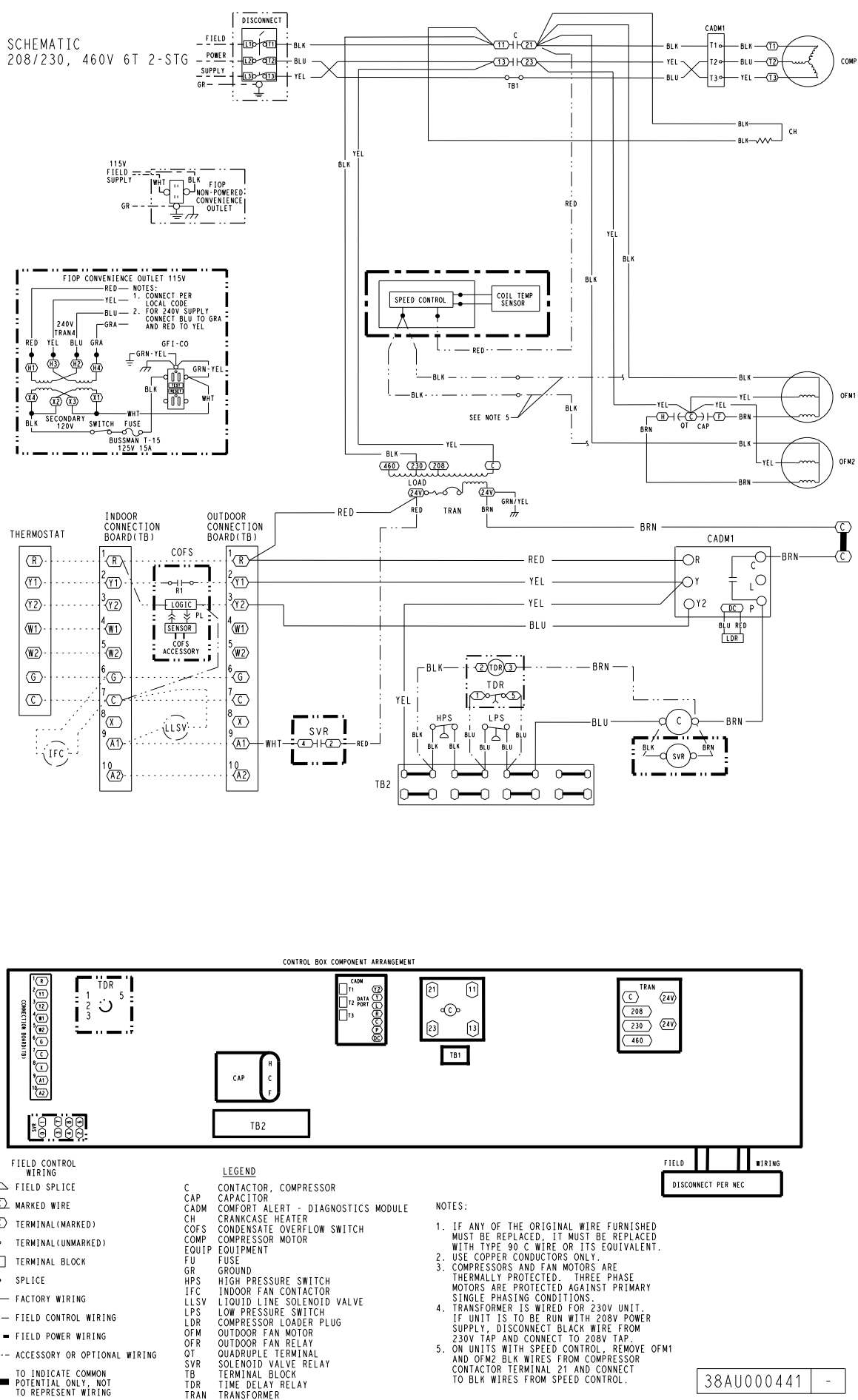

Fig. 25 - Typical Single Circuit / Single Stage CAS072, 091, 120*A/B Wiring Diagram

C10925

SCHEMATIC
208/230, 460V 6T 2-STG



FIELD CONTROL WIRING

△ FIELD SPLICE
 (Y) MARKED WIRE
 (X) TERMINAL (MARKED)
 ○ TERMINAL (UNMARKED)
 [X] TERMINAL BLOCK
 • SPLICE
 — FACTORY WIRING
 - - - FIELD CONTROL WIRING
 - - - FIELD POWER WIRING
 - - - ACCESSORY OR OPTIONAL WIRING
 — TO INDICATE COMMON POTENTIAL ONLY, NOT TO REPRESENT WIRING

LEGEND

C CONTACTOR, COMPRESSOR
 CAP CAPACITOR
 CADM COMFORT ALERT - DIAGNOSTICS MODULE
 CH CRANKCASE HEATER
 COFS CONDENSATE OVERFLOW SWITCH
 COMP COMPRESSOR MOTOR
 EQUIP EQUIPMENT
 FU FUSE
 GR GROUND
 HPS HIGH PRESSURE SWITCH
 IFC INDOOR FAN CONTACTOR
 LLSV LIQUID LINE SOLENOID VALVE
 LPS LOW PRESSURE SWITCH
 LDR COMPRESSOR LOADER PLUG
 OFM OUTDOOR FAN MOTOR
 OFR OUTDOOR FAN RELAY
 OT QUADRUPEL TERMINAL
 SVR SOLENOID VALVE RELAY
 TB TERMINAL BLOCK
 TDR TIME DELAY RELAY
 TRAN TRANSFORMER

NOTES:

1. IF ANY OF THE ORIGINAL WIRE FURNISHED MUST BE REPLACED, IT MUST BE REPLACED WITH TYPE 90 C WIRE OR ITS EQUIVALENT.
2. USE COPPER CONDUCTORS ONLY.
3. COMPRESSORS AND FAN MOTORS ARE THERMALLY PROTECTED. THREE PHASE MOTORS ARE PROTECTED AGAINST PRIMARY SINGLE PHASING CONDITIONS.
4. TRANSFORMER IS WIRED FOR 230V UNIT. IF UNIT IS TO BE RUN WITH 208V POWER SUPPLY, DISCONNECT BLACK WIRE FROM 230V TAP AND CONNECT TO 208V TAP.
5. ON UNITS WITH SPEED CONTROL, REMOVE OFM1 AND OFM2 BLK WIRES FROM COMPRESSOR CONTACTOR TERMINAL 21 AND CONNECT TO BLK WIRES FROM SPEED CONTROL.

38AU000441 -

Fig. 26 - Typical Single Circuit / Two Stage CAS072*G/H Wiring Diagram

C150339

SCHEMATIC
10-12.5T 208/230V DUAL

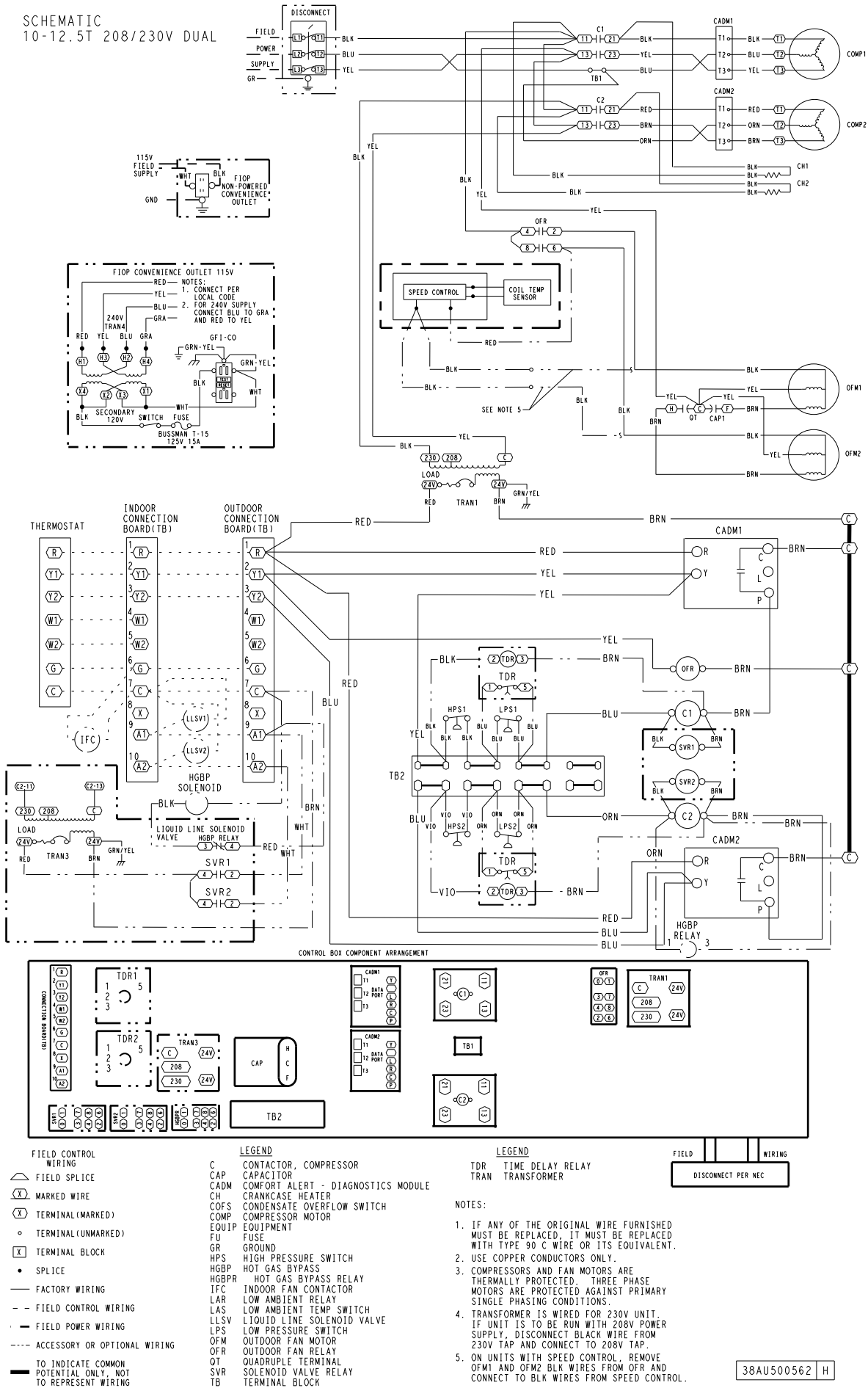

Fig. 27 - Typical Dual Circuit / Two Stage CAS120, 150*D/E Wiring Diagram

OPERATING SEQUENCE

Base Unit Controls

Indoor (Supply) Fan —

The indoor fan contactor (IFC) is remotely located at the fan coil or fan section. If the thermostat fan operation is selected as Continuous, the IFC is energized and the indoor (supply) fan motor runs continuously. If the thermostat fan operation is selected as Automatic, the IFC will be energized on a call for Cooling; indoor (supply) fan motor runs. When thermostat call for Cooling is satisfied, the IFC is de-energized and indoor (supply) fan motor stops.

Cooling, Unit Without Economizer —

CAS072, 091, 121, 151 (Single Circuit)

On a thermostat call for Cooling, IFC will be energized and indoor (supply) fan motor runs. Thermostat output Y1 is energized; terminal Y1 at CAS072, 091, 121, 151 unit receives 24-v. 24-v received at CADM1 terminal Y. If anti-recycle time delay period has not expired, CADM1 relay will remain open, de-energizing Solenoid Valve Relay (SVR) and preventing compressor start. When safety pressure switches are closed and CADM1 time delay expires, CADM1 relay closes, SVR and compressor contactor C1 are energized; liquid line solenoid valve LLSV opens, all outdoor fan motors start and Compressor 1 starts.

As space cooling load is satisfied, thermostat output Y1 is de-energized, removing 24-v at CAS072, 091, 121, 151 terminal Y1. On Y1 opening, Compressor stops, all outdoor fan motors stop and SVR relay is de-energized. Liquid line solenoid valve is de-energized and valve closes. CADM1 begins its three-minute anti-recycle time delay.

CAS072*G/H (Single Circuit/2-Stage)

On a thermostat call for Cooling, IFC will be energized and indoor (supply) fan motor runs. Thermostat output Y1 is energized; terminal Y1 at CAS072*G/H unit receives 24-v. 24-v received at CADM1 terminal Y. If anti-recycle time delay period has not expired, CADM1 relay will remain open, de-energizing Solenoid Valve Relay (SVR) and preventing compressor start. When safety pressure switches are closed and CADM1 time delay expires, CADM1 relay closes, SVR and compressor contactor C1 are energized; liquid line solenoid valve LLSV opens, all outdoor fan motors start and Compressor 1 starts.

On a thermostat calling for Stage 2 Cooling, thermostat output Y2 is energized; terminal Y2 at CAS072*G/H unit receives 24-v. 24-v received at CADM1 terminal Y2. CADM1 DC SOL terminal outputs 24-vdc to the compressor loader plug(LDR) and the compressor operates at full load capacity.

As space cooling load is satisfied, thermostat outputs Y2 and Y1 are sequentially de-energized, removing 24-v at CAS072*G/H terminals Y2 and Y1. Compressor loader plug is de-energized on Y2 opening. On Y1 opening, Compressor 1 stops, all outdoor fan motors stop and SVR relay is de-energized. Liquid line solenoid valve is de-energized and valve closes. CADM1 begins its three-minute anti-recycle time delay.

CAS120, 150 (Two Circuit)

On a thermostat call for Cooling, IFC will be energized and indoor (supply) fan motor runs. Thermostat output Y1 is energized; terminal Y1 at CAS120, 150 unit receives 24-v. 24-v received at CADM1 terminal Y. If anti-recycle time delay period has not expired, CADM1 relay will remain open, de-energizing Solenoid Valve Relay 1 (SVR1) and preventing compressor start. When safety pressure switches are closed and CADM1 time delay expires, CADM1 relay closes, SVR1 and compressor contactor C1 are energized; liquid line solenoid valve LLSV1 opens, all outdoor fan motors start and Circuit 1 compressor starts.

On a thermostat calling for Stage 2 Cooling, thermostat output Y2 is energized; terminal Y2 at CAS120, 150 unit receives 24-v. 24-v received at CADM2 terminal Y. If anti-recycle time delay period has not expired, CADM2 relay will remain open, de-energizing Solenoid Valve Relay 2 (SVR2) and preventing compressor start. When safety pressure switches are closed and CADM2 time delay expires, CADM2 relay closes, SVR2 and compressor contactor C2 are energized; liquid line solenoid valve LLSV2 opens and Circuit 2 compressor starts.

As space cooling load is satisfied, thermostat outputs Y2 and Y1 are de-energized, removing 24-v at CAS120, 150 terminals Y2 and Y1. Circuit 2 compressor stops on Y2 opening; SVR2 is de-energized and LLSV2 closes. CADM2 begins its three-minute anti-recycle time delay. On Y1 opening, Circuit 1 compressor stops, all outdoor fan motors stop and SVR1 relay is de-energized. Liquid line solenoid valve LLSV1 is de-energized and valve closes. CADM1 begins its three-minute anti-recycle time delay.

All Units

If either the Low Pressure Switch or High Pressure Switch opens while thermostat output Y1 or Y2 remain energized, the compressor contactor is de-energized, the compressor stops and liquid line solenoid is de-energized (valve closes). CADM initiates a TRIP event (cooling demand sensed at CADM terminal Y but no current is measured at T1, T2, T3 motor sensors); CADM relay opens and RED LED is illuminated. TRIP condition maintains lockout of compressor operation until CADM is manually reset. Reset CADM by cycling unit main power.

Complete system shutdown may be caused by loss of main power, open compressor internal overload, open low-pressure or high-pressure switch, or a fault detected by the CADM logic. Compressor operation without cooling may indicate the compressor's ASTP feature is active; disconnect unit power and allow compressor to cool. See Service section for further details.

Cooling, Unit With Economizer —

Refer to fan coil unit installation instructions and economizer accessory installation instructions for operating sequences when system is equipped with accessory economizer.

Heating —

Refer to fan coil unit installation instructions and accessory heating device installation instructions for operating sequences in heating mode.

ROUTINE SYSTEM MAINTENANCE

These items should be part of a routine maintenance program, to be checked every month or two, until a specific schedule for each can be identified for this installation:

Quarterly Inspection (and 30 days after initial start) —

Indoor section

- Condenser coil cleanliness checked.
- Return air filter replacement
- Outdoor hood inlet filters cleaned
- Belt tension checked
- Belt condition checked
- Pulley alignment checked
- Fan shaft bearing locking collar tightness checked
- Condensate drain checked

Seasonal Maintenance —

These items should be checked at the beginning of each season (or more often if local conditions and usage patterns dictate):

Air Conditioning

- Condenser fan motor mounting bolts tightness
- Compressor mounting bolts
- Condenser fan blade positioning
- Control box cleanliness and wiring condition
- Wire terminal tightness
- Refrigerant charge level
- Evaporator coil cleaning
- Evaporator blower motor amperage

Heating

- Power wire connections
- Fuses ready
- Manual-reset limit switch is closed

Economizer or Outside Air Damper

- Inlet filters condition
- Check damper travel (economizer)
- Check gear and dampers for debris and dirt

SERVICE

Refrigeration System

⚠ CAUTION

EQUIPMENT DAMAGE HAZARD

Failure to follow this caution may result in damage to equipment.

This system uses R-410A refrigerant which has higher pressures than R-22 and other refrigerants. No other refrigerant may be used in this system. Gauge set, hoses, and recovery system must be designed to handle R-410A. If you are unsure consult the equipment manufacturer.

Compressor Oil —

⚠ CAUTION

EQUIPMENT DAMAGE HAZARD

Failure to follow this caution may result in damage to equipment.

The compressor in a R-410A system uses a polyolester (POE) oil. This oil is extremely hygroscopic, meaning it absorbs water readily. POE oils can absorb 15 times as much water as other oils designed for HCFC and CFC refrigerants. Take all necessary precautions to avoid exposure of the oil to the atmosphere.

Servicing Systems on Roofs With Synthetic Materials —

POE (polyolester) compressor lubricants are known to cause long term damage to some synthetic roofing materials. Exposure, even if immediately cleaned up, may cause embrittlement (leading to cracking) to occur in one year or more. When performing any service which may risk exposure of compressor oil to the roof, take appropriate precautions to protect roofing. Procedures which risk oil leakage include but are not limited to compressor replacement, repairing refrigerants leaks, replacing refrigerant components such as filter drier, pressure switch, metering device, coil, accumulator, or reversing valve.

Synthetic Roof Precautionary Procedure:

1. Cover extended roof working area with an impermeable polyethylene (plastic) drop cloth or tarp. Cover an approximate 10 x 10 ft (3.3 x 3.3 m) area.
2. Cover area in front of the unit service panel with a terry cloth shop towel to absorb lubricant spills and prevent run-offs, and protect drop cloth from tears caused by tools or components.
3. Place terry cloth shop towel inside unit immediately under component(s) to be serviced and prevent lubricant run-offs through the louvered openings in the base pan.
4. Perform required service.
5. Remove and dispose of any oil contaminated material per local codes.

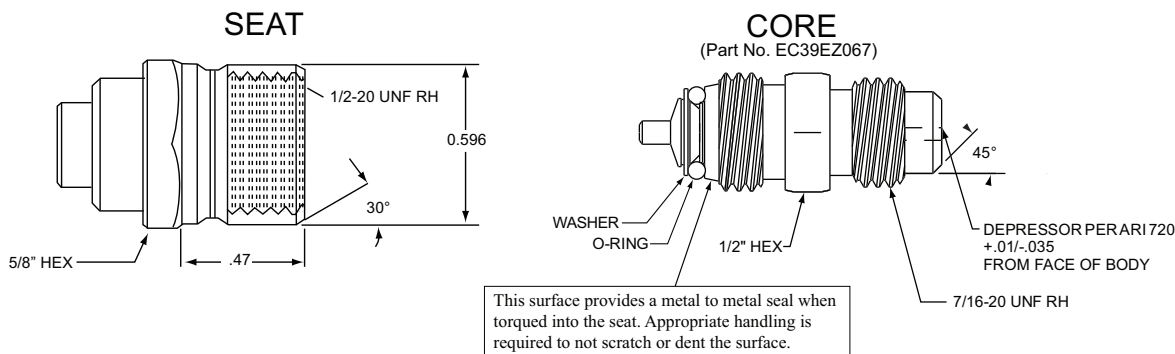

Fig. 28 - CoreMax Access Port Assembly

C08453

Liquid Line Filter Drier —

The factory-provided filter drier is specifically designed to operate with R-410A. Replace the filter drier with factory-authorized components only with a filter drier with desiccant made from 100% molecular sieve grade XH-11. Filter drier must be replaced whenever the refrigerant system is opened.

When removing a filter drier, use a tubing cutter to cut the drier from the system. **Do not unsweat a filter drier** from the system. Heat from unsweating will release moisture and contaminants from drier into system.

Field Refrigerant Access Ports —

Field service access to refrigerant pressures is through the access ports located at the service valves (see Figs 31 and 33). These ports are 1/4-in SAE Flare couplings with Schrader check valves and service caps. Use these ports to admit nitrogen to the field tubing during brazing, to evacuate the tubing and evaporator coil, to admit initial refrigerant charge into the low-side of the system and when checking and adjusting the system refrigerant charge. When service activities are completed, ensure the service caps are in place and secure; check for leaks. If the Schrader check valve must be removed and re-installed, tighten to 2-3 in-lbs (23-34 N-cm).

Factory High-Flow Access Ports —

There are two additional access ports in the system - on the suction tube between the compressor and the suction service valve and on the liquid tube near the liquid service valve (see Figs 32 and 34). These are brass fittings with black plastic caps. The hose connection fittings are standard 1/4-in SAE Male Flare couplings.

The brass fittings are two-piece High Flow valves, with a receptacle base brazed to the tubing and an integral spring-closed check valve core screwed into the base. (See Fig. 28) This check valve is permanently assembled into this core body and cannot be serviced separately; replace the entire core body if necessary. Service tools are available from RCD that allow the replacement of the check valve core without having to recover the entire system refrigerant charge. Apply compressor refrigerant oil to the check valve core's bottom o-ring. Install the fitting body with 96 ±10 in-lbs (1085 ±23 N-cm) of torque; do not overtighten.

Comfort Alert Diagnostic Module

The Comfort Alert Diagnostic Module (CADM) monitors and analyzes data from the Copeland Scroll® three-phase compressor and the thermostat demand. The CADM also provides a 3-minute anti-recycle time delay to compressor cycling. Each compressor has a separate CADM module.

The CADM detects causes for electrical and system related failures without any sensors. Flashing LEDs communicate the Alert codes to guide service technicians in accurately and quickly troubleshooting the system and determining root cause for the failure.

Inputs to the CADM include 24-vac power, thermostat Y1 or Y2, compressor contactor coil (common side) and compressor power leads (from the compressor contactor).

Input	Terminal	Voltage
Control Power	R	24-V
Demand*	Y2	24-V
Control Common	C	24-V
Cooling	Y	24-V
Contactor Coil	P	24-V
Line A	T1	Line
Line B	T2	Line
Line C	T3	Line

* NOTE:Applies to CAS072*07G/H only

Control of the compressor contactor coil is through a normally-closed (power on the module) contact between terminals P and C.

Communications of status and alert conditions is through three LEDs located on the top edge of the module housing (see Fig. 29): POWER (green), ALERT (yellow), and TRIP (red).

The POWER LED indicates the presence of control power to the CADM.

The ALERT LED indicates an abnormal condition exists in the system through a flash code. The ALERT LED will blink a number of times consecutively, pause and the repeat the process. The number of blinks, defined in Table 12, correlates to a particular abnormal condition; troubleshooting tips are provided for each Alert code. Reset of the ALERT may be automatic or manual. If the

fault condition causing the Alert is self-corrected, the Alert code will be removed and the CADM will automatically reset and allow the system to restart normally. Manual reset requires that main power to the CAS unit be recycled after the cause for the Alert condition has been detected and corrected.

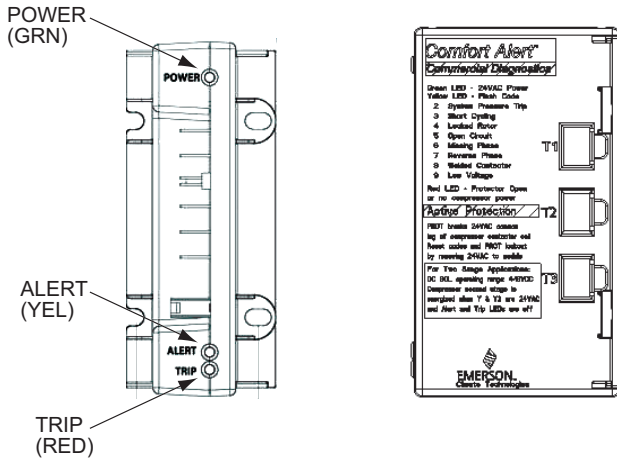

C10086

Fig. 29 - CADM Housing/LED Locations

The TRIP LED indicates either a time-delay period is currently active (RED LED is blinking) or the module has locked out the compressor (RED LED is on steady). A lockout condition will occur when the CADM detects a thermostat demand at input Y but there is no power at the compressor line terminals T1 or T2 or T3. This lockout can occur due to a safety switch (LPS or HPS) opening and de-energizing the compressor contactor, the compressor-motor internal overload opens, or other internal power interruption has occurred. Reset of the TRIP LED requires that unit main power be recycled after the loss of power to the compressor condition has been detected and corrected.

Simultaneous Blinking of YELLOW and RED LEDs indicates control power input to the CADM is low. Check control circuit transformer and wiring.

Troubleshooting the CADM Wiring – Flashing LEDs also indicate wiring problems to the CADM. See Table 13 for discussion of additional LED flash codes and troubleshooting instructions.

Table 12 – LED Status Codes

Status LED	Status LED Description	Status LED Troubleshooting Information
Green "POWER"	Module has power	Supply voltage is present at module terminals
Red "TRIP" LED On Solid	Thermostat demand signal Y is present, but the compressor is not running.	<ol style="list-style-type: none"> 1. Compressor protector is open 2. Condensing unit power disconnect is open 3. Compressor circuit breaker or fuse(s) is open 4. Broken supply wires or connector is not making contact 5. Compressor power wires not routed through Comfort Alert 6. Compressor contactor has failed open
Red "TRIP" LED Flashing	The anti-short cycle timer (3 minutes) in module is preventing compressor restart.	
Module locks out compressor when compressor damaging ALERT code appears. Lockout ALERT codes are noted in the Status LED Description. During a compressor lock out, 24VAC power must be removed from module to manually reset.		
Yellow "ALERT" LED On Solid	A short circuit or over current condition exists on PROT terminal.	<ol style="list-style-type: none"> 1. Compressor contactor coil shorted 2. Electrical load too high for PROT circuit (maximum 1 Amp) 3. 24 V AC wired directly to PROT terminal
Yellow "ALERT" Flash Code 2	System Pressure Trip Discharge pressure out of limits LOCKOUT	<ol style="list-style-type: none"> 1. High head pressure 2. Condenser coil poor air circulation (dirty, blocked, damaged) 3. Condenser fan is not running 4. If low pressure switch is open: <ol style="list-style-type: none"> a. Low refrigerant charge b. Evaporator blower is not running c. Evaporator coil is frozen d. Faulty metering device e. Condenser coil is dirty\ f. Liquid line restriction (filter drier blocked if present)
Yellow "ALERT" Flash Code 3	Short Cycling Compressor is running only briefly (four consecutive cycles of less than three minutes each) LOCKOUT	<ol style="list-style-type: none"> 1. Loose connection between thermostat Y1 and CADM Y terminal. 2. Unit short-cycling on thermostat 3. System or control board defective
Yellow "ALERT" Flash Code 4	Locked Rotor LOCKOUT	<ol style="list-style-type: none"> 1. Low line voltage to compressor 2. Excessive liquid refrigerant in compressor 3. Compressor bearings are seized

Table 12 - LED Status Codes (cont.)

Status LED	Status LED Description	Status LED Troubleshooting Information
Yellow "ALERT" Flash Code 5	Open Circuit	<ol style="list-style-type: none"> 1. Condensing unit power disconnect is open 2. Compressor circuit breaker or fuses are open 3. Compressor contactor has failed open 4. High pressure switch is open and requires manual reset 5. Broken supply wires or connector is not making contact 6. Unusually long compressor protector reset time due to extreme ambient temperature 7. Compressor windings are damaged
Yellow "ALERT" Flash Code 6	Missing Phase LOCKOUT	<ol style="list-style-type: none"> 1. Compressor fuse is open on one phase 2. Broken wire or connector on one phase 3. Compressor motor winding is damaged 4. Utility supply has dropped one phase
Yellow "ALERT" Flash Code 7	Reverse Phase LOCKOUT	<ol style="list-style-type: none"> 1. Compressor running backward due to supply phase reversal
Yellow "ALERT" Flash Code 8	Welded Contactor Compressor always runs	<ol style="list-style-type: none"> 1. Compressor contactor has failed closed 2. Thermostat demand signal not connected to module
Yellow "ALERT" Flash Code 9	Low Voltage Control circuit < 18VAC	<ol style="list-style-type: none"> 1. Control circuit transformer is overloaded 2. Low line voltage to compressor

Table 13 – CADM Troubleshooting

Miswired Module Indication	Recommended Troubleshooting Action
Green LED is not on, module does not power up	Determine if both R and C module terminals are connected. Verify voltage is present at module's R and C terminals. NOTE: The CADM requires a constant nominal 24VAC power supply. The wiring to the module's R and C terminals must be directly from the control transformer. The module cannot receive its power from another device that will interrupt the 24VAC power supply. See the CAS Wiring Diagram(s) (Figs. 25 – 27).
Green LED Intermittent, module powers up only when compressor runs	Determine if R and Y terminals are wired in reverse. Verify module's R and C terminals have a constant source. See " NOTE " above for details on R and C wiring.
TRIP LED is on but system and compressor check OK	Verify Y terminal is wired properly per the CAS wiring diagram (see Figs. 25 – 27). Verify voltage at contactor coil falls below 0.5VAC when off. Verify 24VAC is present across Y and C when thermostat demand signal is present. If not, R and C are reverse wired.
TRIP LED and ALERT LED flashing together	Verify R and C terminals are supplied with 19-28VAC.
ALERT Flash Code 3 (Compressor Short Cycling) displayed incorrectly	Verify Y terminal is connected to 24VAC at contactor coil. Verify voltage at contactor coil falls below 0.5VAC when off.
ALERT Flash Code 5 or 6 (Open Circuit, Missing Phase) displayed incorrectly	Check that compressor T1 and T3 wires are through module's current sensing holes. Verify Y terminal is connected to 24VAC at contactor coil. Verify voltage at contactor coil falls below 0.5VAC when off.
Alert Flash Code * (Welded Contactor) displayed incorrectly	Determine if module's Y terminal is connected. Verify Y terminal is connected to 24VAC at contactor coil. Verify 24VAC is present across Y and C when thermostat demand signal is present. If not, R and C are reverse wired. Verify voltage at contactor coil falls below 0.5VAC when off.

Compressor Protection

Compressor Overtemperature Protection (IP) —

A thermostat installed on the compressor motor winding reacts to excessively high winding temperatures and shuts off the compressor.

Crankcase Heater —

The heater minimizes absorption of liquid refrigerant by oil in the crankcase during brief or extended shutdown periods. The heater is wired to cycle with the compressor; the heater is off when compressor is running, and on when compressor is off.

The crankcase heater will operate as long as the power circuit is energized. The main disconnect must be on to energize the crankcase heater.

IMPORTANT: Never open any switch or disconnect that energizes the crankcase heater unless unit is being serviced or is to be shut down for a prolonged period. After a prolonged shutdown on a service job, energize the crankcase heater for 24 hours before starting the compressor.

Advanced Scroll Temperature Protection (ASTP) —

See “Advanced Scroll Temperature Protection (ASTP)” on page 24.

Low-Pressure Switch —

The CAS low-pressure switch is stem-mounted on the suction line. Switches are all fixed, non-adjustable type.

High-Pressure Switch —

The high-pressure switch is stem mounted on the discharge line. The switch is a fixed, non-adjustable type.

Outdoor Fans —

Each fan is supported by a formed-wire mount bolted to the fan deck and covered with a wire guard. Fan motors have permanently lubricated bearings.

1. Shut off unit power supply. Install lockout tag.
2. Remove outdoor fan assembly (grille, motor, and fan).
3. Loosen fan hub setscrews.
4. Adjust fan height as shown in Fig. 30.
5. Tighten setscrews to 84 in-lbs (949 N-cm).
6. Replace outdoor fan assembly.

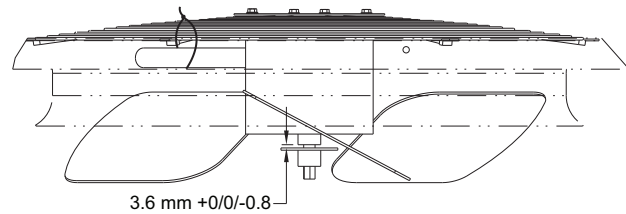

C10103

Fig. 30 - Outdoor Fan Blade Position

Lubrication —

Fan Motors: The fan motors have sealed bearings. No provisions are made for lubrication.

Compressor: The compressor has its own oil supply. Loss of oil due to a leak in the system should be the only reason for adding oil after the system has been in operation.

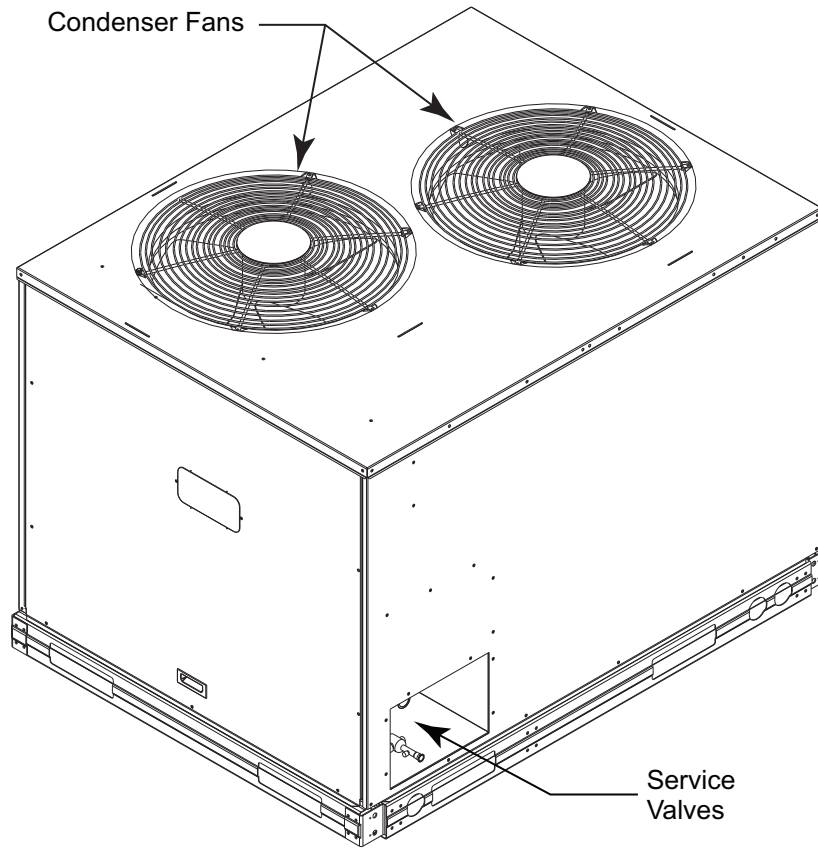

Fig. 31 - Typical Exterior, Single-Circuit Unit (CAS091 shown)

C10927

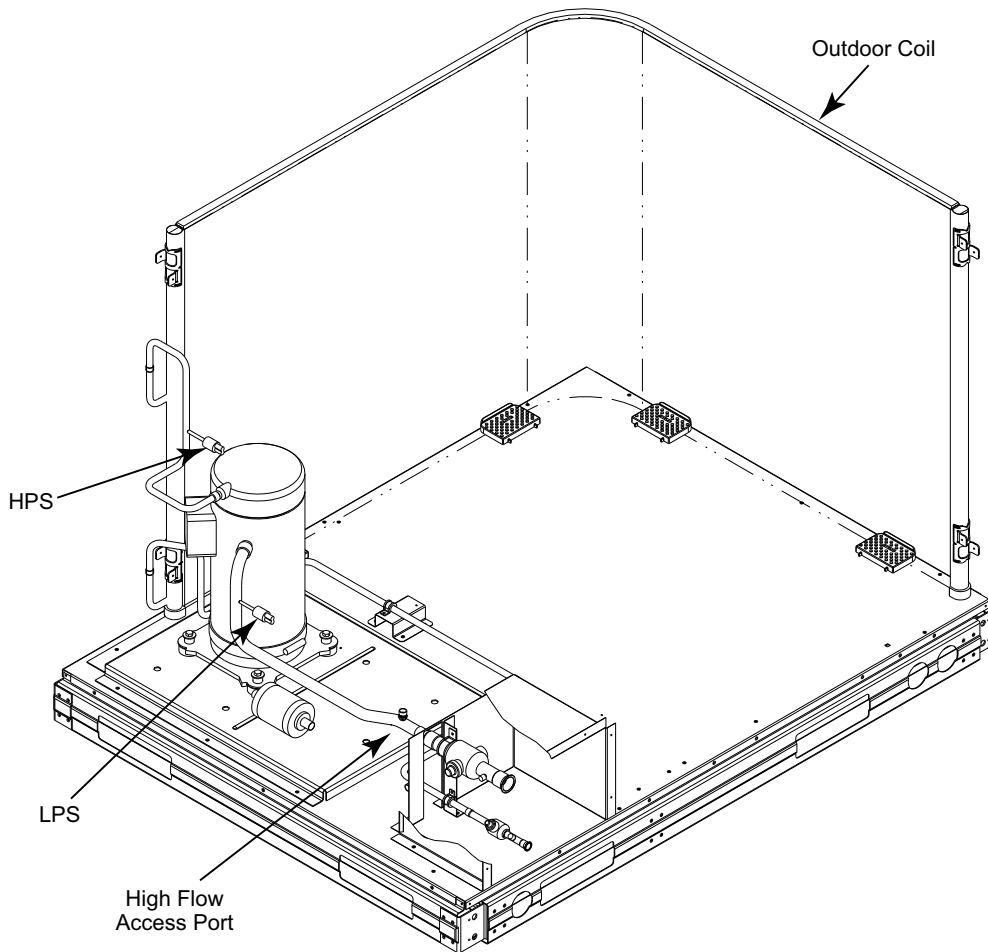

Fig. 32 - Typical Interior, Single-Circuit Unit (CAS091 shown)

C150029

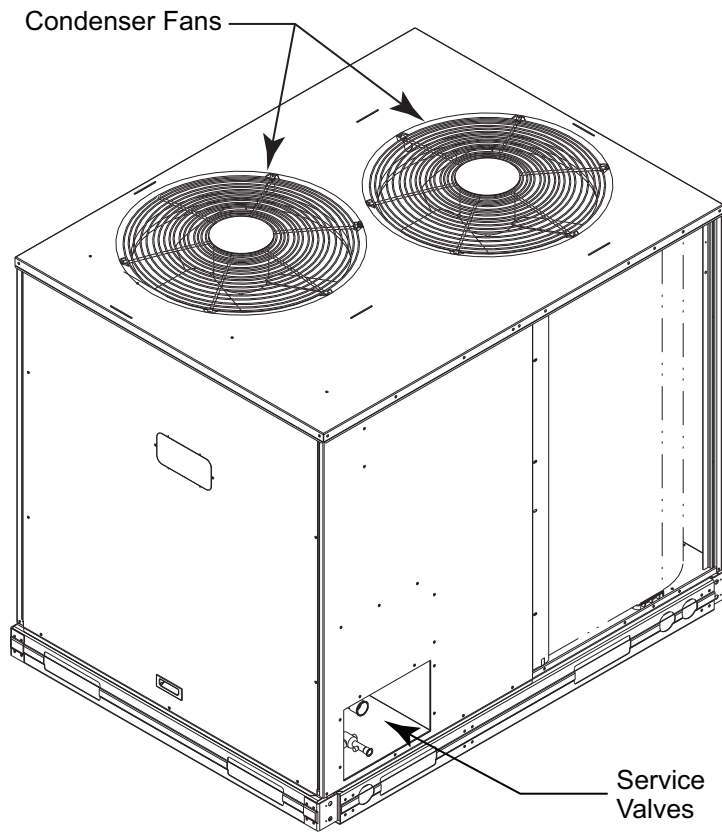

Fig. 33 - Typical Exterior, Two-Circuit Unit (CAS120 shown)

C10929

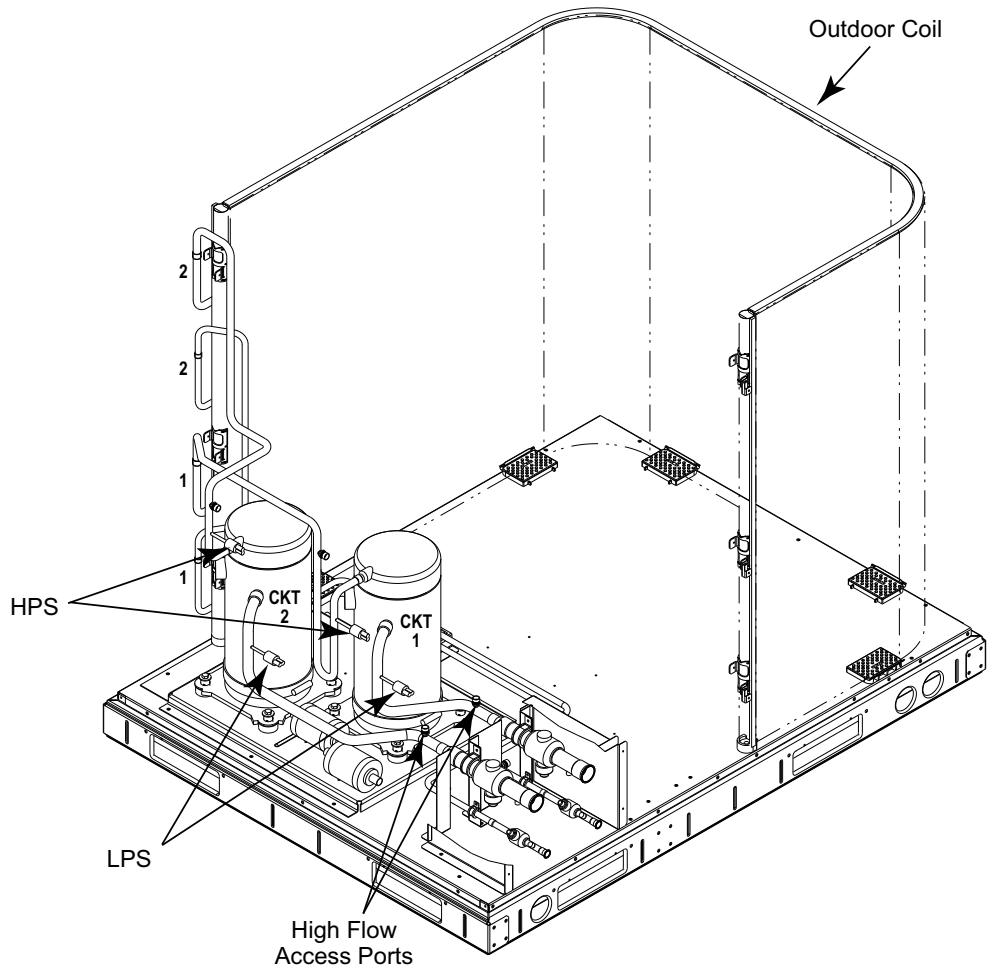

Fig. 34 - Typical Interior, Two-Circuit Unit (CAS120 shown)

C150030

Routine Cleaning of Round-Tube Plate Fin (RTPF) Coils —

Periodic cleaning with environmentally sound coil cleaner is essential to extend the life of RTPF coils. This cleaner is available from FAST Parts. It is recommended that all RTPF coils be cleaned with the environmentally sound coil cleaner as described below.

Coil cleaning should be part of the unit's regularly scheduled maintenance procedures to ensure long life of the coil. Failure to clean the coils may result in reduced durability in the environment.

Avoid the use of:

- coil brighteners
- acid cleaning prior to painting
- high pressure washers
- poor quality water for cleaning

Environmentally sound coil cleaner is non-flammable, hypoallergenic, non-bacterial, and a USDA accepted biodegradable agent that will not harm the coil or surrounding components such as electrical wiring, painted metal surfaces, or insulation. Use of non-recommended coil cleaners is strongly discouraged since coil and unit durability could be affected.

Environmentally Sound Coil Cleaner Application Equipment —

- 2½ gallon garden sprayer
- water rinse with low velocity spray nozzle

⚠ CAUTION

UNIT DAMAGE HAZARD

Failure to follow this caution may result in corrosion and damage to the unit.

Harsh chemicals, household bleach or acid or basic cleaners should not be used to clean outdoor or indoor coils or any kind. These cleaners can be very difficult to rinse out of the coil and can accelerate corrosion at the fin/tube interface where dissimilar materials are in contact. If there is dirt below the surface of the coil use the environmentally sound coil cleaner as described above.

⚠ CAUTION

UNIT RELIABILITY HAZARD

Failure to follow this caution may result in reduced unit performance.

High velocity water from a pressure washer, garden hose, or compressed air should never be used to clean a coil. The force of the water or air jet will bend the fin edges and increase airside pressure drop.

Environmentally Sound Coil Cleaner Application Instructions:

NOTE: Proper eye protection such as safety glasses is recommended during mixing and application.

1. Turn off unit power.
2. Remove screws holding rear corner post and top cover in place. Pivot top cover up 12 to 18 inches (305 to 457 mm) and support with a rigid support. See Fig. 35.

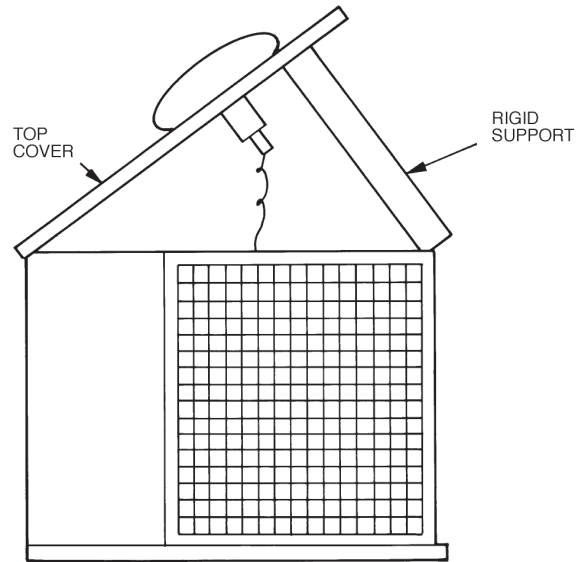

C10216

Fig. 35 - Pivot and Support Top Cover

3. Remove all surface loaded fibers and dirt with a vacuum cleaner. If a vacuum cleaner is not available, a soft non-metallic bristle brush may be used. In either case, the tool should be applied in the direction of the fins. Coil surfaces can be easily damaged (fin edges can be easily bent over and damage to the coating of a protected coil) if the tool is applied across the fins.

NOTE: Use of a water stream, such as a garden hose, against surface loaded coil will drive the fibers and dirt into the coil, making cleaning efforts more difficult. Surface loaded fibers must be completely removed prior to using low velocity clean water rinse.

4. Using a low velocity garden hose thoroughly wet finned surfaces with clean water. Be careful not to bend the fins.
5. Mix environmentally sound coil cleaner in a 2½ gallon garden sprayer according to the instructions included with the cleaner. The optimum solution temperature is 100°F (38°C).

NOTE: Do NOT USE water in excess of 130°F (54°C), as the enzymatic activity will be destroyed.

6. Thoroughly apply environmentally sound coil cleaner solution to all coil surfaces including the finned area, tube sheets and coil headers.
7. Hold garden sprayer nozzle close to finned areas and apply cleaner with a vertical, up-and-down motion. Avoid spraying in horizontal pattern to minimize potential for fin damage.
8. Ensure cleaner thoroughly penetrates deep into finned areas.

9. Interior and exterior finned areas must be thoroughly cleaned.
10. Finned surfaces should remain wet with cleaning solution for 10 minutes.
11. Ensure surfaces are not allowed to dry before rinsing. Reapply cleaner as needed to ensure 10-minute saturation is achieved.
12. Thoroughly rinse all surfaces with low velocity clean water using downward rinsing motion of water spray nozzle. Protect fins from damage from the spray nozzle.
13. Replace top cover and rear corner posts.

FASTENER TORQUE VALUES

Table 14 – Torque Values

Compressor mounting bolts	65–75 in-lbs (734–847 N-cm)
Condenser fan motor mounting bolts	20 ±2 in-lbs (226 ±23 N-cm)
Condenser fan hub setscrew	84 ±2 in-lbs (949 ±136 N-cm)
High-flow service port	96 ±10 in-lbs (1085 ±23 N-cm)
Schrader-type service check valve	2–3 in-lbs (23–34 N-cm)
Compressor oil sightglass thread	330 ±31 in-lbs (23–34 N-cm)
Compressor to Compressor rail torque	120–168 in-lbs (1356–1898 N-cm)
Compressor rail to base pan torque	70 ±5 in-lbs (791 ±57 N-cm)

TROUBLESHOOTING

PROBLEM	SOLUTION
<p>COMPRESSOR DOES NOT RUN</p> <p><u>Contactors Open</u></p> <ol style="list-style-type: none"> 1. Power off. 2. Fuses blown in field power circuit. 3. No control power. 4. Thermostat circuit open. 5. Safety device lockout circuit active. 6. Low-pressure switch open. 7. High-pressure switch open. 8. Compressor overtemperature switch open. 9. Loose electrical connections. 10. Compressor stuck. <p><u>Contactors Closed</u></p> <ol style="list-style-type: none"> 1. Compressor leads loose. 2. Motor windings open. 3. Single phasing. 	<ol style="list-style-type: none"> 1. Restore power. 2. After finding cause and correcting, replace with correct size fuse. 3. Check control transformer primary connections and circuit breaker. 4. Check thermostat setting. 5. Reset lockout circuit. 6. Check for refrigerant undercharge, obstruction of indoor airflow. Make sure liquid line solenoid valve(s) is open. 7. Check for refrigerant overcharge, obstruction of outdoor airflow, air in system. Be sure outdoor fans are operating correctly. 8. Check for open condition. Allow for reset. Replace compressor if necessary. 9. Tighten all connections. 10. See compressor service literature. <ol style="list-style-type: none"> 1. Check connections. 2. See compressor service literature. 3. Check for blown fuse. Check for loose connection at compressor terminal.
<p>COMPRESSOR STOPS ON HIGH-PRESSURE SWITCH</p> <p><u>Outdoor Fan On</u></p> <ol style="list-style-type: none"> 1. High-pressure switch faulty. 2. Reversed fan rotation. 3. Airflow restricted. 4. Air recirculating. 5. Noncondensables in system. 6. Refrigerant overcharge. 7. Line voltage incorrect. 8. Refrigerant system restrictions. <p><u>Outdoor Fan Off</u></p> <ol style="list-style-type: none"> 1. Fan slips on shaft. 2. Motor not running. 3. Motor bearings stuck. 4. Motor overload open. 5. Motor burned out. 	<ol style="list-style-type: none"> 1. Replace switch. 2. Confirm rotation, correct if necessary. 3. Remove obstruction. 4. Clear airflow area. 5. Recover refrigerant and recharge as required. 6. Recover refrigerant as required. 7. Consult power company. 8. Check or replace filter drier, expansion valve, etc. <ol style="list-style-type: none"> 1. Tighten fan hub setscrews. 2. Check power and capacitor. 3. Replace bearings. 4. Check overload rating. Check for fan blade obstruction. 5. Replace motor.

TROUBLESHOOTING (cont)

PROBLEM	SOLUTION
<p>COMPRESSOR CYCLES ON LOW-PRESSURE SWITCH</p> <p><u>Indoor-Air Fan Running</u></p> <ol style="list-style-type: none"> Liquid line solenoid valve(s) fails to open. Filter drier plugged. Expansion valve power head defective. Low refrigerant charge. <p><u>Airflow Restricted</u></p> <ol style="list-style-type: none"> Coil iced up. Coil dirty. Air filters dirty. Dampers closed. <p><u>Indoor-Air Fan Stopped</u></p> <ol style="list-style-type: none"> Electrical connections loose. Fan relay defective. Motor overload open. Motor defective. Fan belt broken or slipping. 	<ol style="list-style-type: none"> Check liquid line solenoid valve(s) for proper operation. Replace if necessary. Replace filter drier. Replace power head. Add charge. Check low-pressure switch setting. <ol style="list-style-type: none"> Check refrigerant charge. Clean coil fins. Clean or replace filters. Check damper operation and position. <ol style="list-style-type: none"> Tighten all connections. Replace relay. Power supply. Replace motor. Replace or tighten belt.
<p>COMPRESSOR RUNNING BUT COOLING INSUFFICIENT</p> <p><u>Suction Pressure Low</u></p> <ol style="list-style-type: none"> Refrigerant charge low. Head pressure low. Air filters dirty. Expansion valve power head defective. Indoor coil partially iced. Indoor airflow restricted. <p><u>Suction Pressure High</u></p> <ol style="list-style-type: none"> Heat load excessive. 	<ol style="list-style-type: none"> Add refrigerant. Check refrigerant charge. Check outdoor-air fan thermostat settings. Clean or replace filters. Replace power head. Check low-pressure setting. Remove obstruction. <ol style="list-style-type: none"> Check for open doors or windows in vicinity of fan coil.
<p>UNIT OPERATES TOO LONG OR CONTINUOUSLY</p> <ol style="list-style-type: none"> Low refrigerant charge. Control contacts fused. Air in system. Partially plugged expansion valve or filter drier. 	<ol style="list-style-type: none"> Add refrigerant. Replace control. Purge and evacuate system. Clean or replace.
<p>SYSTEM IS NOISY</p> <ol style="list-style-type: none"> Piping vibration. Compressor noisy. 	<ol style="list-style-type: none"> Support piping as required. Replace compressor if bearings are worn.
<p>COMPRESSOR LOSES OIL</p> <ol style="list-style-type: none"> Leak in system. Crankcase heaters not energized during shutdown. Improper interconnecting piping design. 	<ol style="list-style-type: none"> Repair leak. Check wiring and relays. Check heater and replace if defective. Check piping for oil return. Replace if necessary.
<p>FROSTED SUCTION LINE</p> <p>Expansion valve admitting excess refrigerant.</p>	<p>Adjust expansion valve.</p>
<p>HOT LIQUID LINE</p> <ol style="list-style-type: none"> Shortage of refrigerant due to leak. Expansion valve opens too wide. 	<ol style="list-style-type: none"> Repair leak and recharge. Adjust expansion valve.
<p>FROSTED LIQUID LINE</p> <ol style="list-style-type: none"> Restricted filter drier. Liquid line solenoid valve partially closed. 	<ol style="list-style-type: none"> Remove restriction or replace. Replace valve.

APPENDIX A

Air Conditioner & Heat Pump with R-410A — Quick Reference Guide

- R-410A refrigerant operates at 50 percent to 70 percent higher pressures than R-22. Be sure that servicing equipment and replacement components are designed to operate with R-410A.
- R-410A refrigerant cylinders are rose colored.
- Recovery cylinder service pressure rating must be 400 psig, DOT 4BA400 or DOT BW400.
- R-410A systems should be charged with liquid refrigerant. Use a commercial type metering device in the manifold hose when charging into suction line with compressor operating.
- Manifold sets should be 700 psig high side and 180 psig low side with 550 psig low-side retard.
- Use hoses with 700 psig service pressure rating.
- Leak detectors should be designed to detect HFC refrigerant.
- R-410A, as with other HFCs, is only compatible with POE oils.
- Vacuum pumps will not remove moisture from oil.
- Use only factory specified liquid-line filter driers with rated working pressures greater than 600 psig.
- Do not install a suction-line filter drier in liquid-line.
- POE oils absorb moisture rapidly. Do not expose oil to atmosphere.
- POE oils may cause damage to certain plastics and roofing materials.
- Wrap all filter driers and service valves with wet cloth when brazing.
- A factory approved, liquid-line filter drier is required on every unit.
- Do not use an R-22 TXV.
- If indoor unit is equipped with a TXV, it must be changed to a R-410A TXV.
- Never open system to atmosphere while it is under a vacuum.
- When system must be opened for service, recover refrigerant, break vacuum with dry nitrogen before opening system.
- Always replace filter drier after opening system for service.
- Do not vent R-410A into the atmosphere.
- Do not use capillary tube coils.
- Observe all **warnings**, **cautions**, and **bold** text.
- All R-410A heat pumps must have indoor TXV.
- Do not leave R-410A suction line driers in place for more than 72 hours.

APPENDIX B

Wiring Diagram List

Unit	Electrical Characteristics	Diagram Number
CAS072*A/B	208/230-3-60	38AU500320
	460-3-60	38AU500432
	575-3-60	38AU500337
CAS072*G/H	208/230-3-60	38AU000441
	460-3-60	38AU000441
	575-3-60	38AU000442
CAS091	208/230-3-60	38AU500320
	460-3-60	38AU500432
	575-3-60	38AU500337
CAS121	208/230-3-60	38AU500320
	460-3-60	38AU500432
	575-3-60	38AU500337
CAS151	208/230-3-60	38AU500107
	460-3-60	38AU500432
	575-3-60	38AU500337
CAS120	208/230-3-60	38AU500562
	460-3-60	38AU500563
	575-3-60	38AU500564
CAS150	208/230-3-60	38AU500562
	460-3-60	38AU500563
	575-3-60	38AU500564

APPENDIX C

Low Ambient Option — Factory Installed

Units with the factory installed low ambient option are equipped with a Motormaster® solid-state head pressure control which regulates fan speed. A temperature sensor, mounted on either circuit 1 (CAS072, 091, 121, 151) or circuit 2 (CAS120, 150) of the outdoor coil controls the speed of approved outdoor fan motors in order to maintain a constant head pressure in the outdoor coil (see Fig. 36 and Fig. 37). The control maintains the appropriate head pressure at low ambient temperatures down to -20°F (-28°C).

Wind baffles are required to prevent wind cross currents from causing abnormally low condensing temperatures.

Use 20-gauge sheet metal to fabricate wind baffles (see Fig. 38 and Table 15).

Operation —

Fan on/off control in cooling-only units (CAS) is provided by an outdoor fan relay (OFR).

In cooling mode, fan motor speed of outdoor motors OFM1 and OFM3 is regulated by the speed control temperature sensor on outdoor coil 1 for a minimum coil condensing temperature of approximately 100°F (38°C) at higher outdoor ambient temperature and 80°F (27°C) at lower ambient. Additionally, outdoor fan motor OFM2 and OFM4 are turned on/off by the low ambient temperature switch, LAS, operating the low ambient relay (LAR). The LAS control temperatures are open 42°F +/- 5°F, close 57°F +/- 5°F (open 5.5°C +/- 2.8°C, close 13.9°C +/- 2.8°C).

To override the speed control for full fan speed operation during service or maintenance, either:

- a. remove sensor and place in hot water >120°F (>49°C).

or

- b. rewire to bypass control by connecting speed control input and output power wires.

Troubleshooting —

OBSERVATION	POSSIBLE REMEDY
Fans won't start	All fans: Check power & wiring Check outdoor fan relay (OFR) OFM1, OFM3 only: Check speed control sensor location Check speed sensor resistance OFM2, OFM4 only: Check low ambient switch (LAS) Check low ambient relay (LAR)
Cooling – Center outdoor fans (OFM2, OFM4) off below approximately 60°F (16°C) outdoor ambient.	Normal operation
Cooling – Center outdoor fans (OFM2, OFM4) not on above approximately 60°F (16°C) outdoor ambient	Check low ambient switch (LAS) Check low ambient relay (LAR)
Cooling – Slow fan speed for outer fans (OFM1, OFM3) at start or during low outdoor ambient	Normal operation
Cooling – Slow fan speed for outer fans (OFM1, OFM3) above 85°F (29°F) outdoor ambient (should be full speed)	Check speed control sensor location Check speed control sensor resistance Check fan motor capacitor
Cooling – motor current into speed control is greater than motor name-plate FLA	Normal operation Up to 30% higher A at partial speed at low ambient

Speed Control Sensor Resistance —

TEMPERATURE		RESISTANCE
°F +/- 2°F°	°C +/- 1C	Ohms, nominal
-22	-30	88350
-4	-20	48485
14	-10	27650
32	0	16325
50	10	9950
68	20	6245
77	25	5000
86	30	4028
104	40	2663
122	50	1801
140	60	1244
158	70	876

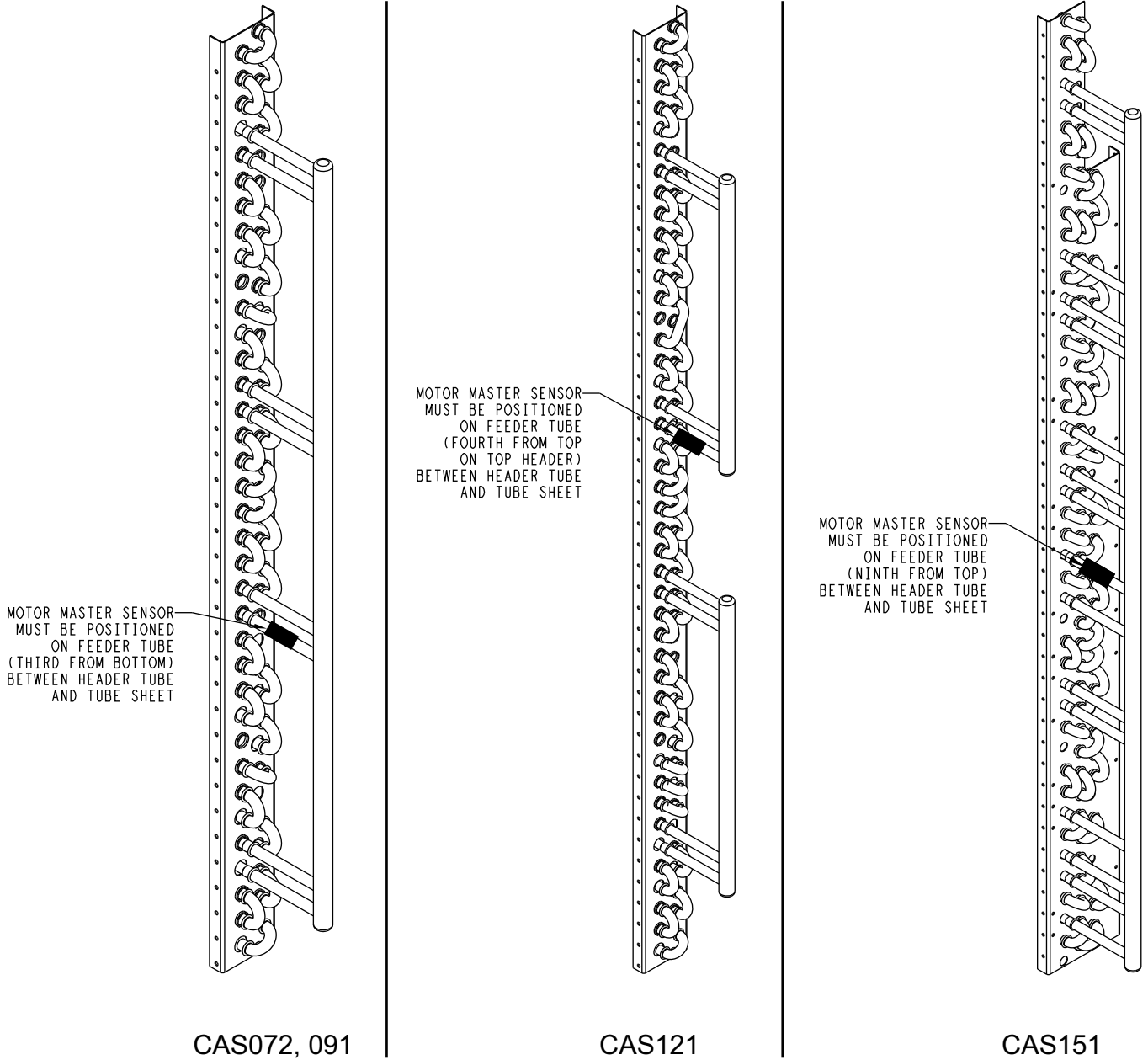
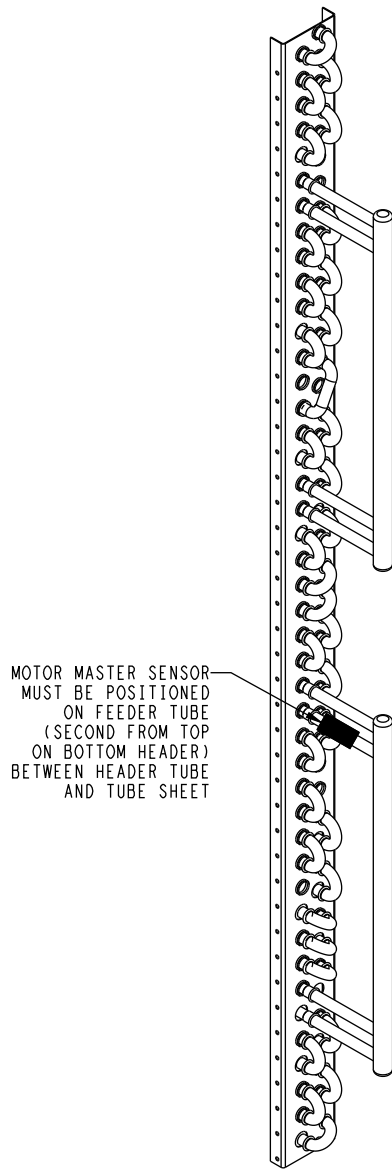

Fig. 36 - CAS072, 091, 121, 151 Motormaster Sensor Locations (RTPF)

C150353



CAS120

MOTOR MASTER SENSOR
MUST BE POSITIONED
ON FEEDER TUBE
(TOP MOST ON
BOTTOM HEADER)
BETWEEN HEADER TUBE
AND TUBE SHEET

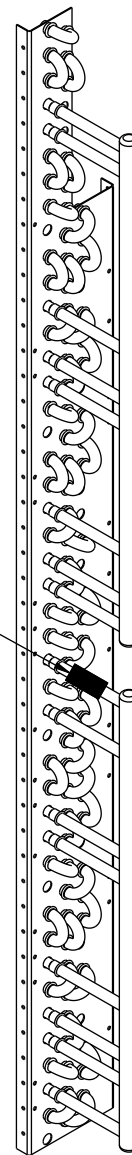

CAS150

Fig. 37 - CAS120, 150 Motormaster Sensor Locations (RTPF)

C150354

0.85 (TYP)

0.47 (TYP)

10" MIN

1.00 MINIMUM (TYP)

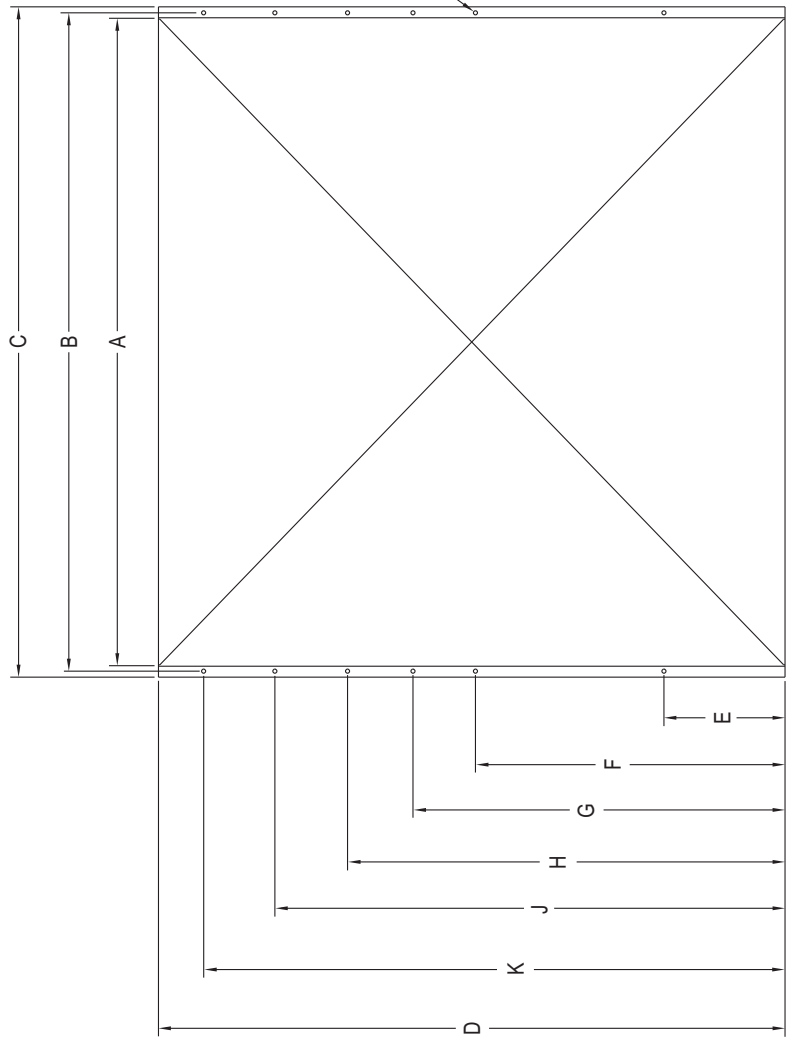
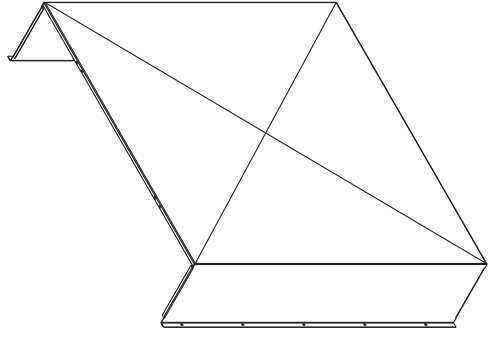

Fig. 38 - Wind Baffles

C10800

Table 15 – Wind Baffle Dimension

DIMENSIONS – INCHES											
UNIT	BAFFLE	A	B	C	D	E	F	G	H	J	K
CAS072	LEFT SIDE	28 1/2	29	29 3/4	35 1/4	1 1/4	9 1/4	17 1/4	25 1/4	33 1/4	–
	BACK	40	40 3/4	41 1/2	35 1/4	4 1/4	11 1/4	18 1/4	25 1/4	32 1/4	–
CAS091	LEFT SIDE	28 1/2	29	29 3/4	35 1/4	1 1/4	9 1/4	17 1/4	25 1/4	33 1/4	–
	BACK	40	40 3/4	41 1/2	35 1/4	4 1/4	11 1/4	18 1/4	25 1/4	32 1/4	–
CAS121/120	LEFT SIDE	40 1/2	41	41 3/4	43 1/8	1 1/4	9 1/4	17 1/4	25 1/4	33 1/4	41 1/4
	BACK	40	40 3/4	41 1/2	43 1/8	4 1/4	11 1/4	18 1/4	25 1/4	32 1/4	39 1/4
CAS151/150	LEFT SIDE	40 1/2	41	41 3/4	43 1/8	1 1/4	9 1/4	17 1/4	25 1/4	33 1/4	41 1/4
	BACK	40	40 3/4	41 1/2	43 1/8	4 1/4	11 1/4	18 1/4	25 1/4	32 1/4	39 1/4
	RIGHT SIDE	25	25 1/2	26 1/4	43 1/8	4 1/4	11 1/4	18 1/4	25 1/4	32 1/4	39 1/4
DIMENSIONS – MM											
UNIT	BAFFLE	A	B	C	D	E	F	G	H	J	K
CAS072	LEFT SIDE	718	737	756	895	33	236	439	643	846	–
	BACK	1016	1035	1054	895	107	284	462	640	818	–
CAS091	LEFT SIDE	718	737	756	895	33	236	439	643	846	–
	BACK	1016	1035	1054	895	107	284	462	640	818	–
CAS121/120	LEFT SIDE	1022	1041	1060	1095	33	236	439	643	846	1049
	BACK	1016	1035	1054	1095	107	284	462	640	818	996
CAS151/150	LEFT SIDE	1022	1041	1060	1095	33	236	439	643	846	1049
	BACK	1016	1035	1054	1095	107	284	462	640	818	996
	RIGHT SIDE	629	648	667	1095	107	284	462	640	818	996

START-UP CHECKLIST

I. PRELIMINARY INFORMATION

OUTDOOR: MODEL NO. _____ SERIAL NO. _____
INDOOR: AIRHANDLER MANUFACTURER _____
MODEL NO. _____ SERIAL NO. _____
ADDITIONAL ACCESSORIES _____

II. PRE-START-UP

OUTDOOR UNIT

IS THERE ANY SHIPPING DAMAGE? (Y/N) _____
IF SO, WHERE: _____

WILL THIS DAMAGE PREVENT UNIT START-UP? (Y/N) _____
CHECK POWER SUPPLY. DOES IT AGREE WITH UNIT? (Y/N) _____
HAS THE GROUND WIRE BEEN CONNECTED? (Y/N) _____
HAS THE CIRCUIT PROTECTION BEEN SIZED AND INSTALLED PROPERLY? (Y/N) _____
ARE THE POWER WIRES TO THE UNIT SIZED AND INSTALLED PROPERLY? (Y/N) _____

CONTROLS

ARE THERMOSTAT AND INDOOR FAN CONTROL WIRING CONNECTIONS MADE AND CHECKED?
(Y/N) _____
ARE ALL WIRING TERMINALS (including main power supply) TIGHT? (Y/N) _____
HAS CRANKCASE HEATER BEEN ENERGIZED FOR 24 HOURS? (Y/N) _____

INDOOR UNIT

HAS WATER BEEN PLACED IN DRAIN PAN TO CONFIRM PROPER DRAINAGE? (Y/N) _____
ARE PROPER AIR FILTERS IN PLACE? (Y/N) _____
HAVE FAN AND MOTOR PULLEYS BEEN CHECKED FOR PROPER ALIGNMENT? (Y/N) _____
DO THE FAN BELTS HAVE PROPER TENSION? (Y/N) _____
HAS CORRECT FAN ROTATION BEEN CONFIRMED? (Y/N) _____

PIPING

ARE LIQUID LINE SOLENOID VALVES LOCATED AT THE INDOOR COILS AS REQUIRED? (Y/N) _____
HAVE LEAK CHECKS BEEN MADE AT COMPRESSOR, OUTDOOR AND INDOOR COILS,
TXVs (Thermostatic Expansion Valves), SOLENOID VALVES, FILTER DRIERS, AND FUSIBLE PLUGS
WITH A LEAK DETECTOR? (Y/N) _____
LOCATE, REPAIR, AND REPORT ANY LEAKS. _____
HAVE LIQUID LINE SERVICE VALVES BEEN OPENED? (Y/N) _____
HAVE SUCTION LINE SERVICE VALVES BEEN OPENED? (Y/N) _____

