



# GPFM / GPCM

## Product Specifications

### 10 SEER PACKAGE GAS / ELECTRIC UNIT (3 Phase) 33.4 to 58 MBtuh

#### REFRIGERATION CIRCUIT

- All models are equipped with high efficiency compressors, scroll on 5 Ton.
- Factory charged with R-22 refrigerant.

#### BUILT TO LAST

- Aluminized serpentine clamshell heat exchanger.
- Galvanized-painted cabinet. One piece weather resistant top. Access panels for easy service. Side by side supply and return. Heavy gauge base rails.
- Triple-coated steel, consisting of a Polyester top coat, a urethane primer coat preceded by an oxide pretreatment.
- Integral base rails with fork-lift access. Holes provided for lifting lugs makes rooftop installation easier.
- Both the condenser and evaporator coils have aluminum fins and copper tubes to promote efficient heat transfer.



#### EASY TO INSTALL AND SERVICE

- Combination gas heating and electric cooling, self contained for year-round comfort. Systems installed on rooftop or ground level. The unit is shipped in the horizontal position and can easily be converted to downflow.
- Externally-mounted gauge ports allow for more accurate reading of operating conditions while servicing.
- Electrical and gas controls located behind one exterior panel for easier maintenance.
- Adjustable electronic fan control with optional low speed continuous fan feature responds quickly to circulate heated air and provide maximum comfort.



#### WARRANTY

- 10 year limited heat exchanger warranty
- 5 year compressor limited warranty
- 1 year parts limited warranty

#### UNIT PERFORMANCE DATA (3 Phase - 60Hz)

MODEL * NUMBER	Voltage	COOLING DATA			HEATING DATA			Unit Dimensions H x W x L	Ship Weight
		Rated Capacity BTUH	S.E.E.R.	E.E.R.	Input (MBTUH) Standard	Efficiency DOE (AFUE) Std.	Efficiency Calif. (CSE) Std.		
GPF/CM36H080(F)	208/230	33,400	10.0	8.5	80	80.0	76.0	29-1/2 X 47-1/2 X 47-1/2	410
GPF/CM36H100(F)	208/230				100	78.0	76.0		
GPF/CM36L080(F)	460	33,400	10.0	8.5	80	80.0	76.0	29-1/2 X 47-1/2 X 47-1/2	410
GPF/CM36L100(F)	460				100	78.0	76.0		
GPF/CM36S100(F)	575	33,400	10.0	8.5	100	78.0	76.0	29-1/2 X 47-1/2 X 47-1/2	410
GPF/CM48H080(F)	208/230	45,500	10.0	9.0	80	80.0	76.0	37-1/2 X 47-1/2 X 51-1/2	490
GPF/CM48H120(F)	208/230				120	80.0	76.0		
GPF/CM48L080(F)	460	45,500	10.0	9.0	80	80.0	76.0	37-1/2 X 47-1/2 X 51-1/2	490
GPF/CM48L120(F)	460				120	80.0	76.0		
GPF/CM48S120(F)	575	45,500	10.0	9.0	120	80.0	76.0	37-1/2 X 47-1/2 X 51-1/2	490
GPF/CM60H100(F)	208/230	58,000	10.0	8.8	100	80.0	76.0	37-1/2 X 47-1/2 X 51-1/2	510
GPF/CM60H140(F)	208/230				140	80.0	76.0		
GPF/CM60L100(F)	460	58,000	10.0	8.8	100	80.0	76.0	37-1/2 X 47-1/2 X 51-1/2	510
GPF/CM60L140(F)	460				140	80.0	76.0		
GPF/CM60S140(F)	575	58,000	10.0	8.	140	80.0	76.0	37-1/2 X 47-1/2 X 51-1/2	510

GPFM = Standard Models, GPCM = models with Nox baffles and meet California emission requirements.

\* (F) = Engineering Model Number (as seen on the unit's rating plate).

509 14 1403 01

8/9/07

## UNIT SPECIFICATIONS

MODEL NUMBER	Electrical Data			Condenser Data									BELS
				Coil			Fan Motor			Fan			
	Voltage Phase - Hz	HACR Breaker / Max. Fuse	Ampacity	Total Face Area (Sq. Ft.)	Fins Per In. / Rows	Tube Diameter (In.)	HP	Full Load Amps	RPM (Max)	Size Diameter (In.)	No. Blades Pitch °	CFM (Max.)	
GP*M36H080(F)	208/230-3-60	20 amps	17.1	8.0	20 / 2	3/8	1/3	1.9	1140	20.3	3 -27	3000	7.8
GP*M36H100(F)	208/230-3-60	20 amps	17.1	8.0	20 / 2	3/8	1/3	1.9	1140	20.3	3 -27	3000	7.8
GP*M36L080(F)	460-3-60	15 amps	9.0	8.0	20 / 2	3/8	1/3	.74	1140	20.3	3 -27	3000	7.8
GP*M36L100(F)	460-3-60	15 amps	9.0	8.0	20 / 2	3/8	1/3	.74	1140	20.3	3 -27	3000	7.8
GP*M36S080(F)	575-3-60	15 amps	7.0	8.0	20 / 2	3/8	1/3	.60	1140	20.3	3 -27	3000	7.8
GP*M36S100(F)	575-3-60	15 amps	7.0	8.0	20 / 2	3/8	1/3	.60	1140	20.3	3 -27	3000	7.8
GP*M48H080(F)	208/230-3-60	30 amps	21.1	10.5	20 / 2	3/8	1/3	1.9	1140	20.3	3 -27	3000	7.8
GP*M48H120(F)	208/230-3-60	30 amps	21.1	10.5	20 / 2	3/8	1/3	1.9	1140	20.3	3 -27	3000	7.8
GP*M48L080(F)	460-3-60	15 amps	10.2	10.5	20 / 2	3/8	1/3	.75	1140	20.3	3 -27	3000	7.8
GP*M48L120(F)	460-3-60	15 amps	10.2	10.5	20 / 2	3/8	1/3	.75	1140	20.3	3 -27	3000	7.8
GP*M48S080(F)	575-3-60	15 amps	8.4	10.5	20 / 2	3/8	1/3	.60	1140	20.3	3 -27	3000	7.8
GP*M48S120(F)	575-3-60	15 amps	8.4	10.5	20 / 2	3/8	1/3	.60	1140	20.3	3 -27	3000	7.8
GP*M60H100(F)	208/230-3-60	45 amps	30.3	14.9	20 / 2	3/8	1/3	1.9	1140	20.3	3 -27	3000	8.0
GPFM60H140(E)	208/230-3-60	45 amps	30.3	14.9	20 / 2	3/8	1/3	1.9	1140	20.3	3 -27	3000	8.0
GPCM60H140(F)	208/230-3-60	45 amps	30.3	14.9	20 / 2	3/8	1/3	1.9	1140	20.3	3 -27	3000	8.0
GP*M60L100(F)	460-3-60	20 amps	13.9	14.9	20 / 2	3/8	1/3	.75	1140	20.3	3 -27	3000	8.0
GPFM60L140(E)	460-3-60	20 amps	13.9	14.9	20 / 2	3/8	1/3	.75	1140	20.3	3 -27	3000	8.0
GPCM60L140(F)	460-3-60	20 amps	13.9	14.9	20 / 2	3/8	1/3	.75	1140	20.3	3 -27	3000	8.0
GP*M60S100(F)	575-3-60	15 amps	11.9	14.9	20 / 2	3/8	1/3	.60	1140	20.3	3 -27	3000	8.0
GPFM60S140(E)	575-3-60	15 amps	11.9	14.9	20 / 2	3/8	1/3	.60	1140	20.3	3 -27	3000	8.0
GPCM60S140(F)	575-3-60	15 amps	11.9	14.9	20 / 2	3/8	1/3	.60	1140	20.3	3 -27	3000	8.0

\* F = GPFM Standard Models, C = GPCM models with Nox baffles and meet California emission requirements.

MODEL NUMBER	Evaporator Coil									Compressor			Factory Refrigerant Charge R-22 (Oz.)	Ship Weight (Lbs.)
	Coil			Blower H.P. / Type / Speeds	Motor		Blower			Type	Rated Load Amps	Locked Rotor Amps		
	Total Face Area (Sq. Ft.)	Fins Per In. / Rows	Tube Diam. (In.)		Full Load Amps	Locked Rotor Amps	Type & Size	RPM (Max)	CFM Rated					
GP*M36H080(F)	3.66	14 / 3	3/8	1/2 / PSC / 3	3.6	7.50	DD11-9A	1000	1250	Recip	9.7	72	89	410
GP*M36H100(F)	3.66	14 / 3	3/8	1/2 / PSC / 3	3.6	7.50	DD11-9A	1000	1250	Recip	9.7	72	89	410
GP*M36L080(F)	3.66	14 / 3	3/8	1/2 / PSC / 3	2.0	4.15	DD11-9A	1000	1250	Recip	5.0	33	89	410
GP*M36L100(F)	3.66	14 / 3	3/8	1/2 / PSC / 4	2.0	4.15	DD11-9A	1000	1250	Recip	5.0	33	89	410
GP*M36S080(F)	3.66	14 / 3	3/8	1/2 / PSC / 1	1.5	3.60	DD11-9A	1000	1250	Recip	3.9	27	89	410
GP*M36S100(F)	3.66	14 / 3	3/8	1/2 / PSC / 1	1.5	3.60	DD11-9A	1000	1250	Recip	3.9	27	89	410
GP*M48H080(F)+	5.33	14 / 3	3/8	1/2 / PSC / 3	3.6	7.50	DD11-9A	1000	1600	Recip	12.5	91	102	490
GP*M48H120(F)+	5.33	14 / 3	3/8	1/2 / PSC / 4	3.6	7.50	DD11-9A	1000	1600	Recip	12.5	91	102	490
GP*M48L080(F)+	5.33	14 / 3	3/8	1/2 / PSC / 3	2.0	4.50	DD11-9A	1000	1600	Recip	6.0	42	102	490
GP*M48L120(F)+	5.33	14 / 3	3/8	1/2 / PSC / 3	2.0	4.50	DD11-9A	1000	1600	Recip	6.0	42	102	490
GP*M48S080(F)	5.33	14 / 3	3/8	1/2 / PSC / 1	1.5	3.60	DD11-11A	1000	1600	Recip	5.0	39	102	490
GP*M48S120(F)	5.33	14 / 3	3/8	1/2 / PSC / 1	1.5	3.60	DD11-11A	1000	1600	Recip	5.0	39	102	490
GP*M60H100(F)	5.33	14 / 4	3/8	1 / PSC / 4	6.0	15.0	DD12-12A	1000	1900	Scroll	17.9	124	136	510
GPFM60H140(E)	5.33	14 / 4	3/8	1 / PSC / 4	6.0	15.0	DD12-12A	1000	1900	Scroll	17.9	124	136	510
GPCM60H140(F)	5.33	14 / 4	3/8	1 / PSC / 4	6.0	15.0	DD12-12A	1000	1900	Scroll	17.9	124	136	510
GP*M60L100(F)	5.33	14 / 4	3/8	1 / PSC / 4	2.5	7.2	DD12-12A	1000	1900	Scroll	8.9	59.6	136	510
GPFM60L140(E)	5.33	14 / 4	3/8	1 / PSC / 4	2.5	7.2	DD12-12A	1000	1900	Scroll	8.9	59.6	136	510
GPCM60L140(F)	5.33	14 / 4	3/8	1 / PSC / 4	2.5	7.2	DD12-12A	1000	1900	Scroll	8.9	59.6	136	510
GP*M60S100(F)	5.33	14 / 4	3/8	1 / PSC / 1	2.4	5.80	DD12-12A	1000	1900	Scroll	7.1	49.4	136	510
GPFM60S140(E)	5.33	14 / 4	3/8	1 / PSC / 1	2.4	5.80	DD12-12A	1000	1900	Scroll	7.1	49.4	136	510
GPCM60S140(F)	5.33	14 / 4	3/8	1 / PSC / 1	2.4	5.80	DD12-12A	1000	1900	Scroll	7.1	49.4	136	510

\* F = GPFM Standard Models, C = GPCM models with Nox baffles and meet California emission requirements.

+ GP\*M48\*120 have DD11-11 blower.

**Air Filters** are supplied with these units, 3 to 5 ton use 14 x 25 x 1 (2)

SPECIFICATIONS SUBJECT TO CHANGE WITHOUT NOTICE

**PERFORMANCE DATA: HEATING**

MODEL NUMBER	Input (MBTUH)	Output (MBTUH)	Efficiency **		Temperature Rise ° F	Gas Piping Size (In.)	Transformer Size Va.
	Standard	Standard	DOE (AFUE)	Calif. (CSE)			
			Std.	Std.			
GP*M36(H,L,S)080(F)	80	64	80.0	76.0	35-65	1/2	65
GP*M36(H,L,S)100(F)	100	80	80.0	76.0	35-65	1/2	65
GP*M48(H,L,S)080(F)	80	64	80.0	76.0	35-65	1/2	65
GP*M48(H,L,S)120(F)	120	96	80.0	76.0	40-70	1/2	65
GP*M60(H,L,S)100(F)	100	80	80.0	76.0	30-60	1/2	65
GPFM60(H,L,S)140(E)	140	112	80.0	76.0	35-65	1/2	65
GPCM60(H,L,S)140(F)	140	112	80.0	76.0	35-65	1/2	65

\* F = GPFM Standard Models, C = GPCM models with Nox baffles and meet California emission requirements.

\*\* As determined by D.O.E. Annual Fuel Utilization Efficiency (A.F.U.E.) Rating Test. Heating capacity valid for elevations up to 2,000 feet above sea level. For elevations above 2,000 feet, rated capacity should be reduced by 4% for each 1,000 feet above sea level. All models meet California C.S.E. and NOx standards.

**PERFORMANCE DATA: COOLING**

MODEL NUMBER	Rated Capacity <sup>1</sup> BTUH	S / T Ratio	S.E.E.R.	E.E.R. <sup>3</sup>	Power Input Watts	Evaporator Rated Airflow (SCFM)	Ext. Static Pressure Drop <sup>2</sup> Wet
GP*M36(H,L,S)080(F)	33,400	.75	10.0	8.5	4000	1100	.15
GP*M36(H,L,S)100(F)							
GP*M48(H,L,S)080(F)	45,500	.79	10.0	9.0	5115	1600	.15
GP*M48(H,L,S)120(F)							
GPFM60(H,L,S)100(E)	58,000	.75	10.0	8.8	6480	1900	.15
GPCM60(H,L,S)140(F)							

\* F = GPFM Standard Models, C = GPCM models with Nox baffles and meet California emission requirements.

<sup>1</sup> Rated Capacity @ ARI standard conditions, 95° Amb, 80° DB/67° WB, 230 Volts. For applications at 208 volts deduct 1000 BTU.

<sup>2</sup> Includes a .08 drop for a filter

<sup>3</sup> For reference only

**BLOWER PERFORMANCE DATA**

MODEL * NUMBER	MOTOR SPEED	Air Delivery in CFM at ESP**			
		0.20	0.30	0.40	0.50
GP*M36H GP*M48H	HI	1649	1621	1595	1562
	MD	1284	1281	1255	1239
	LO	1091	1073	1072	1059
GP*M36L GP*M48L	HI	1949	1881	1818	1741
	MD HI	1637	1589	1540	1487
	MD	1383	1353	1319	1280
	LO	1289	1267	1236	1208
GP*M36S	HI	1733	1695	1655	1587
GP*M48S	HI	1840	1781	1722	1659
GP*M60(H,L)	HI	1983	1910	1837	1750
	MD HI	1915	1852	1783	1710
	MD	1805	1748	1693	1634
	LO	1700	1666	1578	1531
GP*M60(S)	HI	2108	2039	1856	1759

\* F = GPFM Standard Models, C = GPCM models with Nox baffles and meet California emission requirements.

\*\*Air delivery against shown external static pressures taken with 230V to unit and dry coil. For wet coil subtract approximately 25 CFM. Add .08 static for internal filters.



**EXPANDED PERFORMANCE DATA (COOLING) - 5 TON (GROSS DATA)**

Airflow			Outdoor Ambient Temperature - Degrees F. Dry Bulb																							
			65				75				85				95				105				115			
			Entering Indoor Temperature - Degrees F. Wet Bulb																							
IDB*	CFM		59	63	67	71	59	63	67	71	59	63	67	71	59	63	67	71	59	63	67	71	59	63	67	71
70	2128	MBh	60.5	62.7	68.7	-	59.1	61.2	67.1	-	57.6	59.8	65.5	-	56.2	58.3	63.9	-	53.4	55.4	60.7	-	49.5	51.3	56.2	-
		S/T	0.75	0.63	0.44	-	0.78	0.65	0.45	-	0.80	0.67	0.46	-	0.83	0.69	0.48	-	0.86	0.72	0.50	-	0.86	0.72	0.50	-
		KW	5.23	5.34	5.49	-	5.61	5.72	5.89	-	5.93	6.05	6.24	-	6.22	6.35	6.55	-	6.47	6.60	6.81	-	6.68	6.82	7.04	-
	1900	MBh	58.7	60.8	66.7	-	57.3	59.4	65.1	-	56.0	58.0	63.6	-	54.6	56.6	62.0	-	51.9	53.8	58.9	-	48.1	49.8	54.6	-
		S/T	0.72	0.60	0.42	-	0.74	0.62	0.43	-	0.76	0.64	0.44	-	0.79	0.66	0.46	-	0.82	0.68	0.47	-	0.82	0.69	0.48	-
		KW	5.20	5.30	5.45	-	5.56	5.67	5.84	-	5.89	6.01	6.19	-	6.17	6.30	6.50	-	6.42	6.55	6.76	-	6.63	6.77	6.98	-
1672	MBh	55.8	57.8	63.3	-	54.5	56.5	61.9	-	53.2	55.1	60.4	-	51.9	53.8	58.9	-	49.3	51.1	56.0	-	45.6	47.3	51.8	-	
	S/T	0.69	0.57	0.40	-	0.71	0.60	0.41	-	0.73	0.61	0.42	-	0.75	0.63	0.44	-	0.78	0.65	0.45	-	0.79	0.66	0.46	-	
	KW	5.12	5.22	5.37	-	5.48	5.59	5.75	-	5.80	5.92	6.09	-	6.08	6.20	6.39	-	6.32	6.45	6.65	-	6.52	6.66	6.87	-	
75	2128	MBh	61.5	63.3	68.5	73.5	60.1	61.8	66.9	71.8	58.6	60.4	65.3	70.1	57.2	58.9	63.7	68.4	54.3	55.9	60.6	65.0	50.3	51.8	56.1	60.2
		S/T	0.86	0.77	0.58	0.37	0.89	0.79	0.60	0.39	0.91	0.81	0.62	0.40	0.94	0.84	0.64	0.41	0.97	0.87	0.66	0.42	0.98	0.88	0.67	0.43
		KW	5.27	5.38	5.53	5.70	5.65	5.76	5.93	6.12	5.98	6.10	6.29	6.48	6.27	6.40	6.60	6.81	6.52	6.66	6.86	7.08	6.73	6.88	7.09	7.32
	1900	MBh	59.7	61.5	66.5	71.4	58.3	60.0	65.0	69.7	56.9	58.6	63.4	68.1	55.5	57.2	61.9	66.4	52.8	54.3	58.8	63.1	48.9	50.3	54.5	58.4
		S/T	0.82	0.73	0.55	0.36	0.85	0.76	0.57	0.37	0.87	0.78	0.59	0.38	0.90	0.80	0.61	0.39	0.93	0.83	0.63	0.40	0.94	0.84	0.63	0.41
		KW	5.23	5.34	5.49	5.66	5.61	5.72	5.89	6.07	5.93	6.06	6.24	6.43	6.22	6.35	6.55	6.75	6.47	6.60	6.81	7.03	6.68	6.82	7.04	7.26
1672	MBh	56.7	58.4	63.2	67.8	55.4	57.0	61.7	66.3	54.1	55.7	60.3	64.7	52.8	54.3	58.8	63.1	50.1	51.6	55.9	59.9	46.4	47.8	51.7	55.5	
	S/T	0.78	0.70	0.53	0.34	0.81	0.73	0.55	0.35	0.83	0.74	0.56	0.36	0.86	0.77	0.58	0.37	0.89	0.80	0.60	0.39	0.90	0.80	0.61	0.39	
	KW	5.16	5.26	5.41	5.57	5.52	5.63	5.80	5.98	5.84	5.96	6.14	6.33	6.13	6.25	6.45	6.65	6.37	6.50	6.70	6.91	6.58	6.71	6.92	7.15	
80	2128	MBh	62.6	63.9	68.3	73.0	61.1	62.5	66.7	71.3	59.7	61.0	65.1	69.6	58.2	59.5	63.6	67.9	55.3	56.5	60.4	64.5	51.2	52.3	55.9	59.8
		S/T	0.94	0.88	0.72	0.54	1.00	0.91	0.74	0.56	1.00	0.94	0.76	0.57	1.00	0.97	0.79	0.59	1.00	1.00	0.82	0.61	1.00	1.00	0.82	0.62
		KW	5.31	5.42	5.58	5.74	5.69	5.81	5.98	6.16	6.03	6.15	6.34	6.53	6.32	6.45	6.65	6.86	6.57	6.71	6.92	7.14	6.79	6.93	7.15	7.38
	1900	MBh	60.8	62.1	66.3	70.9	59.3	60.6	64.8	69.3	57.9	59.2	63.2	67.6	56.5	57.8	61.7	66.0	53.7	54.9	58.6	62.7	49.7	50.8	54.3	58.0
		S/T	0.90	0.84	0.68	0.51	0.93	0.87	0.71	0.53	0.95	0.89	0.73	0.54	0.98	0.92	0.75	0.56	1.00	0.96	0.78	0.58	1.00	0.96	0.78	0.59
		KW	5.27	5.38	5.53	5.70	5.65	5.76	5.93	6.12	5.98	6.10	6.29	6.48	6.27	6.40	6.60	6.81	6.52	6.66	6.87	7.08	6.74	6.88	7.09	7.32
1672	MBh	57.7	59.0	63.0	67.4	56.4	57.6	61.5	65.8	55.0	56.2	60.1	64.2	53.7	54.9	58.6	62.7	51.0	52.1	55.7	59.5	47.2	48.3	51.6	55.1	
	S/T	0.86	0.80	0.65	0.49	0.89	0.83	0.68	0.51	0.91	0.86	0.70	0.52	0.94	0.88	0.72	0.54	0.98	0.92	0.75	0.56	0.99	0.92	0.75	0.56	
	KW	5.20	5.30	5.45	5.61	5.56	5.67	5.84	6.02	5.89	6.01	6.19	6.38	6.17	6.30	6.50	6.70	6.42	6.55	6.76	6.97	6.63	6.77	6.98	7.20	
85	2128	MBh	63.7	64.9	68.0	72.5	62.2	63.4	66.4	70.8	60.7	61.9	64.8	69.1	59.2	60.4	63.2	67.5	56.3	57.4	60.1	64.1	52.1	53.1	55.6	59.4
		S/T	0.98	0.95	0.86	0.70	1.00	0.98	0.89	0.72	1.00	1.00	0.91	0.74	1.00	1.00	0.94	0.76	1.00	1.00	0.98	0.79	1.00	1.00	0.98	0.80
		KW	5.35	5.46	5.62	5.79	5.73	5.85	6.03	6.21	6.07	6.20	6.39	6.59	6.37	6.50	6.70	6.92	6.62	6.76	6.98	7.20	6.84	6.99	7.21	7.44
	1900	MBh	61.8	63.0	66.0	70.4	60.4	61.5	64.5	68.8	58.9	60.1	62.9	67.1	57.5	58.6	61.4	65.5	54.6	55.7	58.3	62.2	50.6	51.6	54.0	57.6
		S/T	0.94	0.91	0.82	0.66	0.97	0.94	0.85	0.69	1.00	0.96	0.87	0.71	1.00	0.99	0.90	0.73	1.00	1.00	0.93	0.76	1.00	1.00	0.94	0.76
		KW	5.31	5.42	5.58	5.74	5.69	5.81	5.98	6.16	6.03	6.15	6.34	6.53	6.32	6.45	6.65	6.86	6.57	6.71	6.92	7.14	6.79	6.93	7.15	7.38
1672	MBh	58.7	59.9	62.7	66.9	57.4	58.5	61.2	65.3	56.0	57.1	59.8	63.8	54.6	55.7	58.3	62.2	51.9	52.9	55.4	59.1	48.1	49.0	51.3	54.8	
	S/T	0.90	0.87	0.78	0.64	0.93	0.90	0.81	0.66	0.96	0.92	0.83	0.68	0.99	0.95	0.86	0.70	1.00	0.99	0.89	0.72	1.00	1.00	0.90	0.73	
	KW	5.23	5.34	5.49	5.66	5.61	5.72	5.89	6.07	5.93	6.05	6.24	6.43	6.22	6.35	6.55	6.75	6.47	6.60	6.81	7.03	6.68	6.82	7.04	7.26	

\* Entering Indoor Temperature - Degrees F. Dry Bulb



Standard Rating

## ACCESSORIES

### ROOF CURBS, TRANSITION AND DUCT KITS

Used on (Unit Size)	8" Curb	14" Curb	24" Curb	Square to Round Transition Kit	Round Duct Size (Inches)	Concentric Grill Flush Mount	Concentric Grill Step Down
3 Ton	ACL01FB0A *	ACM01FB0A *	ACH01FB0A *	ACT01FB0A	16	AXB020CFA	AXB020CSA
	AXB020CLA **	AXB020CMA **	AXB020CHA **	AXB020CTA	16	AXB020CFA	AXB020CSA
4 - 5 Ton	ACL02FB0A *	ACM02FB0A *	ACH02FB0A *	ACT02FB0A	18	AXB030CFA	AXB030CSA
	AXB020CLA **	AXB020CMA **	AXB020CHA **	ACT22FB0A	18	AXB030CFA	AXB030CSA

### ROOF CURB DIMENSIONS (AC SERIES)

Model No.	A	B	C	D	E	F	G	H	K (ACL)	K (ACM)	K (ACH)
AC(L,M,H)01FB0A	42-1/2	39-1/2	16	21-1/2	2	45-3/4	42-3/4	20	8	14	24
AC(L,M,H)02FB0A	44-3/4	41-3/4	18-7/8	20-7/8	2	45-3/4	42-3/4	22	8	14	24

### ROOF CURB DIMENSIONS (AX SERIES)

Model No.	A	B	C	D	E	F	G	H	K (CLA)	K (CMA)	K (CHA)
AXB020C(L,M,H)A**	42-3/4	39-3/4	18	18	3-3/4	42-3/4	39-3/4	18	8	14	24

\* Full Perimeter Curbs

\*\* AXB curbs are not full perimeter curbs. Three ton units have a 3 inch overhang on the control access panel end of the unit. The 4 & 5 ton units have a 3 to 4 inch overhang on the back and sides. There will be some supply air blockage, but this does not affect the performance of the unit.

### ECONOMIZERS

Description	Mainline Model Number	Used on
Fully Modulating Horizontal	AHE01FB0A	3 Ton
Fully Modulating Horizontal	AHE02FB0A	4 to 5 Ton
Fully Modulating Downflow	AEM01FB0A	3 Ton
3 Position Horizontal	AHP01FB0A	3 Ton
3 Position Horizontal	AHP02FB0A	4 to 5 Ton
3 Position Downflow	AEP01FB0A	3 Ton

### FRESH AIR DAMPERS

Description	Mainline Model Number	Used on
35% Manual Fresh Air Damper	AFA01FB0A	3 Ton
35% Manual Fresh Air Damper	AFA02FB0A	4 to 5 Ton
35% Motorized Fresh Air Damper	AFM01FB0A	3 Ton
35% Motorized Fresh Air Damper	AFM02FB0A	4 to 5 Ton

### RETURN AIR FILTER KIT

Description	Mainline Model Number	Used on
Return Air Filter Kit	AKF12FB0A	ALL

Filters not included in kit, small chassis uses 12 x 25 x 1 (2 ea), large chassis uses 14 x 25 x 1 (2 ea)

### HAIL GUARD

Description	Mainline Model Number	Used on
Hail Guard	AGH01FB0A	3 Ton
	AGH02FB0A	4 to 5 Ton

### FOSSIL FUEL CONVERSION (0' to 2000')

Description	Service Parts Number *	Used on Heat Input
Natural to LP Gas	1172663	80 MBTUH
Natural to LP Gas	1172662	100, 120, 140 MBTUH
LP to Natural Gas	1172664	80 MBTUH
LP to Natural Gas	1098575	100, 120, 140 MBTUH

\* Available through Service Parts only. For High Altitude conversions, see installation instructions.

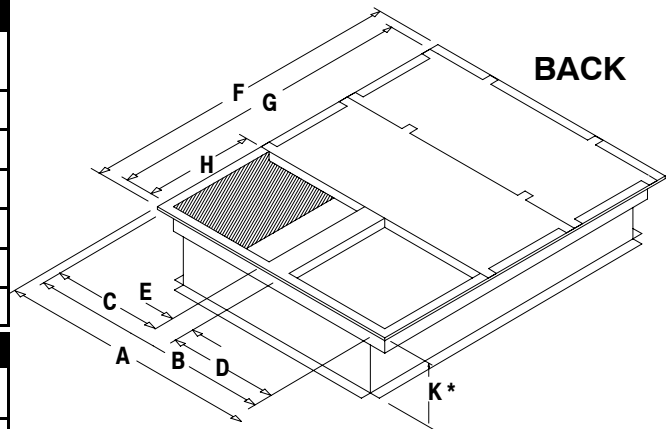

**Curb Dimensions**

Roof Curbs available in 8", 14" and 24" Heights (K Dimensions)

**UNIT DIMENSIONS**

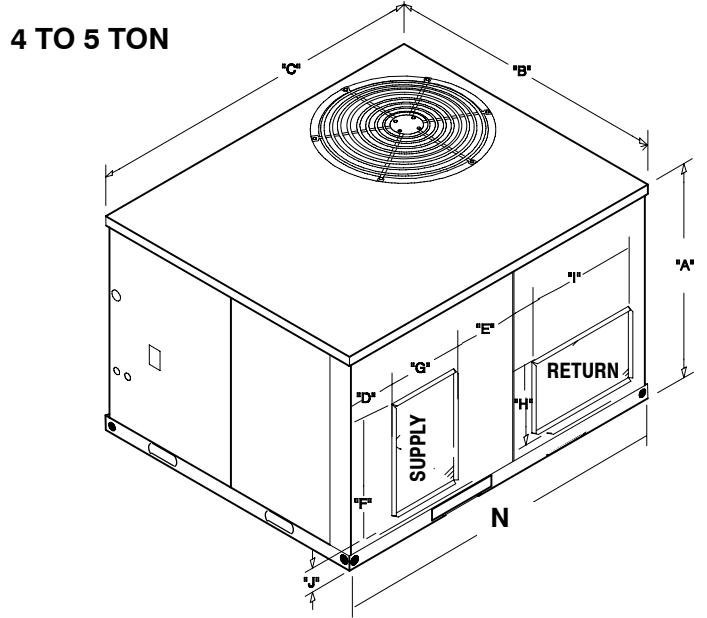
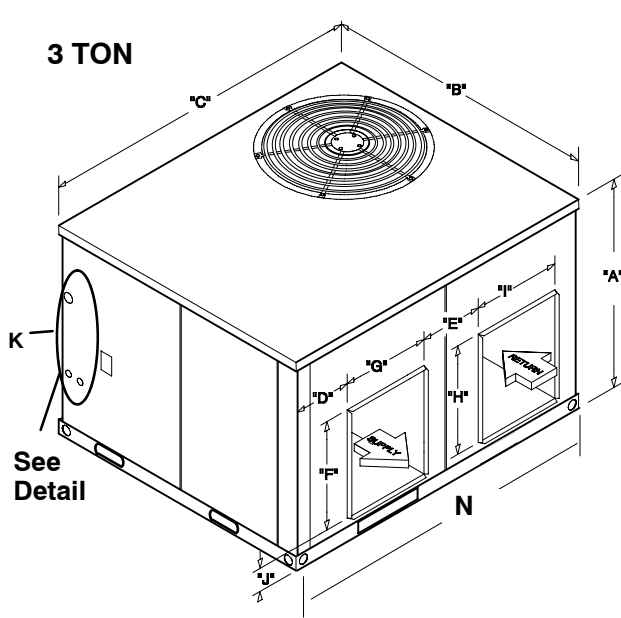

**BASE PAN**

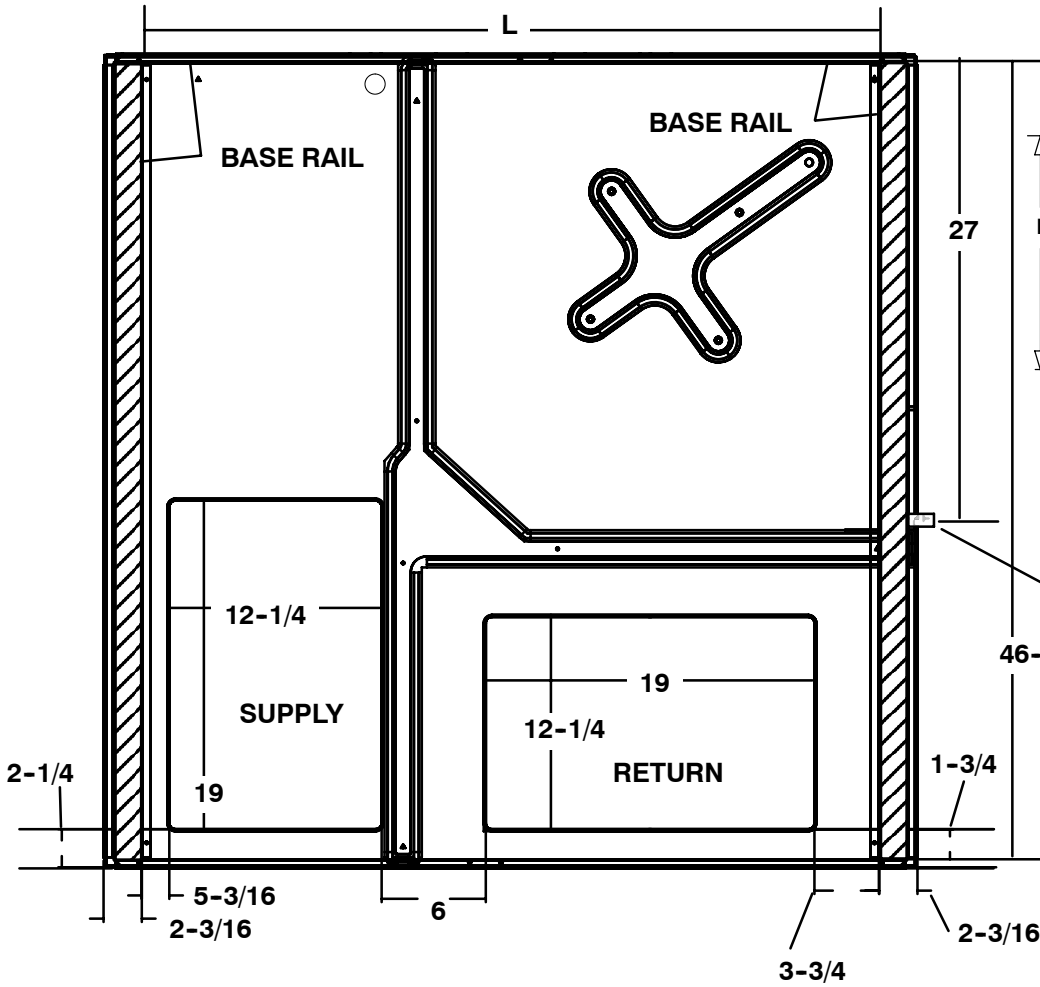

ALL DIMENSIONS IN INCHES

**Connections Detail**

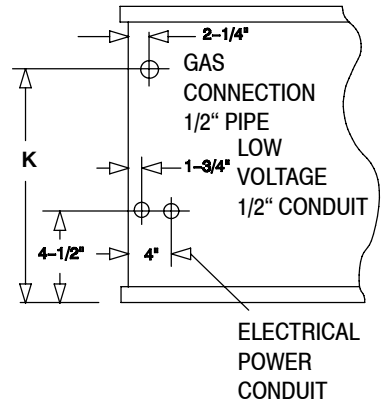

**Condensate Drain**

46-1/8\*\*

UNIT SIZE	A	B	C	D	E	F	G	H	I	J	K	L	M	N
3 Ton	29-1/2	47-1/2	47-1/2	3	9-1/2	12	14	12	14	4-1/2	16	42-3/4	1-9/16	46-1/2
4 TO 5 Ton	37-1/2	47-1/2	51-1/2	7-1/2	6-1/2	19	12	12	19	4-1/2	22	46-1/4	5-3/16	49-3/4

\*\* Measured from inside to inside on base rails.

## MODEL NUMBER IDENTIFICATION GUIDE

MODEL NUMBER	G	P	F	M36	H	060	F = Engineering Code	
GAS ELECTRIC							GAS HEAT INPUT	060 = 60,000
								100 = 100,000    120 = 120,000
								080 = 80,000    140 = 140,000
P = Single Package							ELECTRICAL CHARACTERISTICS	
							H = 208 / 230-3-60	
							L = 460-3-60	
							S = 575-3-60	
F = STANDARD SERIES							COOLING CAPACITY (NOMINAL BTUH)	
C = Models with Nox baffles and meet California emission requirements.							36 = 3 ton	
							48 = 4 Ton    60 = 5 Ton	

## GUIDE SPECIFICATION

### CABINET

The cabinet is made of triple-coated steel, consisting of a Polyester top coat, a urethane primer coat preceded by an oxide pretreatment. One piece weather resistant top. The base rails are 16 gauge steel with fork lift slots and holes provided for lifting shackles. The unit is designed with convertible airflow for either horizontal or downflow applications with conversion accomplished by re-locating two panels. Indoor blower compartment interior cabinet surfaces are insulated with a minimum 1/2" thick, flexible glass insulation, coated on the air side. Aluminum foil faced glass fiber insulation is used in the furnace compartment.

### COOLING SECTION

The unit is factory charged and operationally ready upon delivery. The unit refrigerant circuit has a high efficiency fully hermetic compressor (5 ton has scroll compressor) with internal overload protection, and copper tube / aluminum fin evaporator and condenser coils. The unit is designed for cooling operation to 40° F and will be capable of being wired for field installed economizer type accessories.

### COILS

The evaporator and condenser coils are fabricated with aluminum fins mechanically bonded to copper tubing. Both coils are pressure tested prior to assembly into the unit and electronically leak tested after assembly into the unit.

### CONDENSER FAN

The unit has a single direct-drive propeller-fan / motor assembly. The assembly is mounted directly to a vertical-discharge grille that is easily removed for service. Motors are 1100 RPM with sleeve or ball bearings and internal overload protection.

### EVAPORATOR BLOWER

All units have a direct-drive evaporator blower motor as a standard. The direct-drive evaporator blower motor has sleeve bearings and internal overload protection.

### HEATING SECTION

The gas-fired heating section features an induced draft blower for combustion air. The unit has an aluminized steel serpentine clamshell heat exchanger located on the discharge air side of the blower. The system uses in-shot burners ignited by a hot surface pilot ignition system, protected by both a high heat limit switch and flame roll-out switch. The induced draft blower motor is interlocked with a proven air pressure safety device.

### RIGGING DETAILS

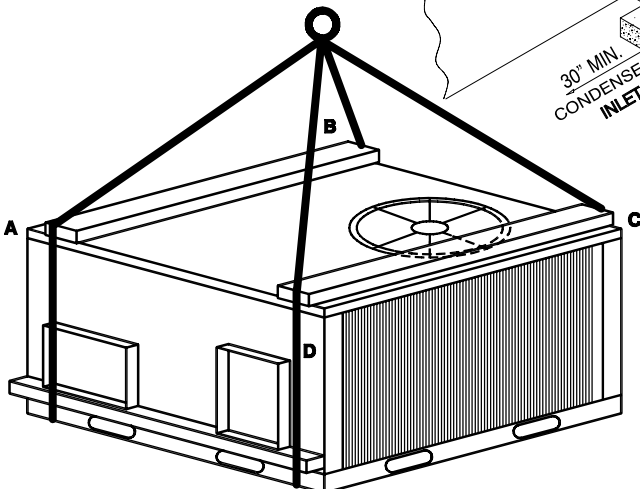

### INSTALLATION CLEARANCES

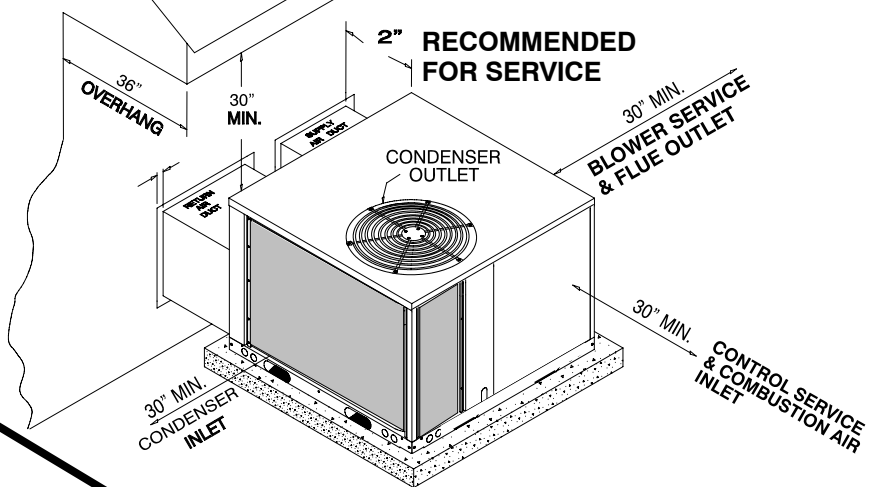

### CORNER WEIGHTS (LBS)

UNIT SIZE	A	B	C	D	OPERATING WEIGHT TOTAL
3 TON	82	103	143	82	410
4 TON	98	123	171	98	490
5 TON	100	125	175	100	500