

### HIGH-EFFICIENCY PACKAGE GAS HEATING/ELECTRIC COOLING, R-410A SINGLE PACKAGE ROOFTOP 3 - 12.5 TONS [1 & 3-Phase]

#### BUILT TO LAST, EASY TO INSTALL AND SERVICE

- R-410A HFC refrigerant
- ASHRAE 90.1-2013 compliant and ENERGY STAR\* certified
- Single-stage cooling capacity control on all 036-072 models
- Two-stage cooling capacity control on 073 -150 models.
- Rated in accordance with AHRI Standard 210/240 [036-060 sizes] and 340/360 [072-150 sizes]
- Designed in accordance with Underwriters' Laboratories Standard 1995
- Listed by UL and UL, Canada or ETL, ETL Canada
- Exclusive non-corrosive composite condensate pan in accordance with ASHRAE 62 Standard, sloping design; side or center drain
- Gas efficiencies up to 82%<sup>†</sup>
- Induced draft combustion
- Redundant gas valve, with 1 or 2 stages of heating
- Pre-painted exterior panels and primer-coated interior panels tested to 500 hours salt spray protection
- TXV refrigerant metering device on each circuit.
- Exclusive IGC solid-state control for on-board diagnostics with LED error code designation, burner control logic and energy saving indoor fan motor delay
- "Low NO<sub>x</sub>" models available that meet California Air Quality Management NO<sub>x</sub> requirements and include stainless steel heat exchangers
- Cooling operating range from 35 F up to 125 F. 110 size model standard cooling operation down to 0°F [-18°C]
- Access panels with easy grip handles and no-strip screw feature
- Two-inch disposable return air filters
- Tool-less filter access door
- Belt drive evaporator-fan motor and pulley combinations available on all three phase models
- Direct Drive x13 [5 speed/torque] motor on 036 to 060 models
- Central terminal board for simple safety circuit troubleshooting and control box arrangement
- Field convertible from vertical to horizontal airflow on all models. No special kit required on 036-120 models. Supply duct kit required for 150 size model only.
- Provisions for thru-the-bottom power entry capability single point gas and electric connections
- Full perimeter base rail with built-in rigging adapters and fork truck slots
- Scroll compressors with internal line-break overload protection
- Copper tube, aluminum fin coils
- 24-volt control circuit protected with resettable circuit breaker
- Permanently lubricated evaporator-fan motor
- Permanently lubricated, totally enclosed, shaft down condenser motors
- Low-pressure, freeze protection, and high-pressure switches
- Exclusive IGC anti-cycle protection for gas heat operation
- Solid-state electronic direct spark ignition system
- Liquid line filter drier

#### WARRANTY

- 15 Year limited warranty on optional stainless steel heat exchanger
- 10 year limited warranty on aluminized heat exchanger
- 5 Year compressor limited warranty
- 1 Year parts limited warranty



RGH036-060



RGH072-120



OR



Use of the AHRI Certified TM Mark indicates a manufacturer's participation in the program. For verification of certification for individual products, go to [www.ahridirectory.org](http://www.ahridirectory.org).



\* ENERGY STAR is a registered trademark of the U.S. Environmental Protection Agency.

<sup>†</sup> Gas efficiencies up to 82% achieved by all units except size 150 of standard units and all sizes of low NO<sub>x</sub> units.

## TABLE OF CONTENTS

	PAGE		PAGE
UNIT PERFORMANCE DATA .....	2	APPLICATION DATA .....	34
MODEL NUMBER NOMENCLATURE .....	3	SELECTION PROCEDURE .....	36
FACTORY OPTIONS AND/OR ACCESSORIES .....	5	COOLING TABLES .....	37
AHRI COOLING RATING TABLES .....	12	STATIC PRESSURE ADDERS .....	57
SOUND PERFORMANCE TABLE .....	14	ECONOMIZER, BAROMETRIC RELIEF & PE. PERFORMANCE .....	58
MIN/MAX AIRFLOW RATINGS TABLE .....	15	FAN PERFORMANCE .....	60
PHYSICAL DATA .....	16	ELECTRICAL INFORMATION .....	76
CURB & WEIGHTS DIMENSIONS .....	21	SEQUENCE OF OPERATION .....	90
OPTIONS & ACCESSORY WEIGHTS .....	33	GUIDE SPECIFICATIONS .....	93

### UNIT PERFORMANCE DATA - SINGLE STAGE COOLING (Single Phase Units)

UNIT	Nom. Tons	COOLING			GAS HEATING		Unit Dimensions H x W x L in [mm]	Unit Weight lb. [kg]
		Net Cap. [Btuh]	SEER	EER	Input Cap. [Btuh]	Thermal Eff. %		
RGH036K^XA0AAA	3	36,000	15.0	12.50	65,000-90,000	82	33-3/8 x 46-3/4 x 74-3/8 [847 x 1187 x 1888]	505 [229]
RGH048K^XA0AAA	4	48,500	15.6	13.00	65,000-130,000	80-82	41-3/8 x 46-3/4 x 74-3/8 [1051 x 1187 x 1888]	590 [268]
RGH060K^XA0AAA	5	57,500	15.2	12.45	65,000-130,000	80-82	41-3/8 x 46-3/4 x 74-3/8 [1051 x 1187 x 1888]	600 [271]

### UNIT PERFORMANCE DATA - SINGLE STAGE COOLING (Three Phase Units)

UNIT	Nom. Tons	COOLING			GAS HEATING		Unit Dimensions H x W x L in [mm]	Unit Weight lb. [kg]
		Net Cap. [Btuh]	SEER	EER	Input Cap. [Btuh]	Thermal Eff. %		
RGH036*^XA0AAA	3	36,000	15.0	12.50	72,000-115,000	81-82	33-3/8 x 46-3/4 x 74-3/8 [847 x 1187 x 1888]	505 [229]
RGH048*^XA0AAA	4	48,500	15.6	13.00	72,000-150,000	80-82	41-3/8 x 46-3/4 x 74-3/8 [1051 x 1187 x 1888]	590 [268]
RGH060*^XA0AAA	5	57,500	15.2	12.45	72,000-150,000	80-82	41-3/8 x 46-3/4 x 74-3/8 [1051 x 1187 x 1888]	600 [271]
RGH072*^AA0AAA	6	73,000	N/A	12.00	72,000-150,000	80-82	41-1/4 x 59-1/2 x 88-1/8 [1048 x 1510 x 2238]	765 [347]

### UNIT PERFORMANCE DATA - TWO STAGE COOLING

UNIT	Nom. Tons	COOLING			GAS HEATING		Unit Dimensions H x W x L in [mm]	Unit Weight lb. [kg]
		Net Cap. [Btuh]	SEER	EER	Input Cap. [Btuh]	Thermal Eff. %		
RGH073*^AA0AAA	6	72,000	N/A	12.00	72,000-150,000	80-82	41-1/4 x 59-1/2 x 88-1/8 [1048 x 1510 x 2238]	765 [347]
RGH090*^AA0AAA	7.5	89,000	N/A	12.00	125,000-224,000	82	49-3/8 x 59-1/2 x 88-1/8 [1253 x 1510 x 2238]	925 [420]
RGH102*^AA0AAA	8.5	97,000	N/A	12.00	125,000-224,000	82	49-3/8 x 59-1/2 x 88-1/8 [1253 x 1510 x 2238]	925 [420]
RGH110*^AA0AAA	10	111,000	N/A	12.00	180,000-250,000	80-82	49-3/8 x 59-1/2 x 88-1/8 [1253 x 1510 x 2238]	1090 [495]
RGH120*^AA0AAA	10	115,000	N/A	11.50	180,000-250,000	80-82	49-3/8 x 59-1/2 x 88-1/8 [1253 x 1510 x 2238]	1090 [495]
RGH150*^AA0AAA	12.5	146,000	N/A	12.20	150,000-240,000	80-81	57-3/8 x 63-3/8 x 115-7/8 [1456 x 1609 x 2942]	1430 [649]

### UNIT PERFORMANCE DATA FOR LOW NO<sub>x</sub> MODELS

UNIT	Nom. Tons	COOLING			GAS HEATING		Unit Dimensions H x W x L in [mm]	Unit Weight lb. [kg]
		Net Cap. [Btuh]	SEER	EER	Input Cap. [Btuh]	Thermal Eff. %		
RGH036*^XA0AAA	3	36,000	15.0	12.50	60,000-90,000	81	33-3/8 x 46-3/4 x 74-3/8 [847 x 1187 x 1888]	505 [229]
RGH048*^XA0AAA	4	48,500	15.6	13.00	60,000-120,000	81	41-3/8 x 46-3/4 x 74-3/8 [1051 x 1187 x 1888]	590 [268]
RGH060*^XA0AAA	5	57,500	15.2	12.45	60,000-120,000	80-81	41-3/8 x 46-3/4 x 74-3/8 [1051 x 1187 x 1888]	602 [273]

\* Indicates Unit voltage (Nom. V-Ph-Hz): K = 208/230-1-60, H = 208/230-3-60, L = 460-3-60, S = 575-3-60

^ See model nomenclature listing for gas heating options.

# MODEL NOMENCLATURE

MODEL SERIES	R	G	H	0	9	0	H	D	A	A	0	A	A	A										
Position Number	1	2	3	4	5	6	7	8	9	10	11	12	13	14										
R = Rooftop																								
G = Gas/Electric <span style="float: right;">Type</span>																								
H = High-Efficiency <span style="float: right;">Efficiency</span>																								
<table style="width: 100%; border: none;"> <tr> <td style="width: 50%;">036 = 3 Tons</td> <td style="width: 50%;">090 = 7.5 Tons (Dual Compressor)</td> </tr> <tr> <td>048 = 4 Tons</td> <td>102 = 8.5 Tons (Dual Compressor)</td> </tr> <tr> <td>060 = 5 Tons</td> <td>110 = 10 Tons (Dual Compressor) (12.0 EER)</td> </tr> <tr> <td>072 = 6 Tons (Single Compressor/Single Stage)</td> <td>120 = 10 Tons (Dual Compressor) (11.5 EER)</td> </tr> <tr> <td>073 = 6 Tons (Single Compressor/2-Stage)</td> <td>150 = 12.5 Tons (Dual Compressor)</td> </tr> </table> <p style="text-align: center;"><b>Nominal Cooling Capacity</b></p>															036 = 3 Tons	090 = 7.5 Tons (Dual Compressor)	048 = 4 Tons	102 = 8.5 Tons (Dual Compressor)	060 = 5 Tons	110 = 10 Tons (Dual Compressor) (12.0 EER)	072 = 6 Tons (Single Compressor/Single Stage)	120 = 10 Tons (Dual Compressor) (11.5 EER)	073 = 6 Tons (Single Compressor/2-Stage)	150 = 12.5 Tons (Dual Compressor)
036 = 3 Tons	090 = 7.5 Tons (Dual Compressor)																							
048 = 4 Tons	102 = 8.5 Tons (Dual Compressor)																							
060 = 5 Tons	110 = 10 Tons (Dual Compressor) (12.0 EER)																							
072 = 6 Tons (Single Compressor/Single Stage)	120 = 10 Tons (Dual Compressor) (11.5 EER)																							
073 = 6 Tons (Single Compressor/2-Stage)	150 = 12.5 Tons (Dual Compressor)																							
<table style="width: 100%; border: none;"> <tr> <td style="width: 50%;">K = 208/230-1-60</td> <td style="width: 50%;">L = 460-3-60</td> </tr> <tr> <td>H = 208/230-3-60</td> <td>S = 575-3-60</td> </tr> </table> <p style="text-align: right;"><b>Voltage</b></p>															K = 208/230-1-60	L = 460-3-60	H = 208/230-3-60	S = 575-3-60						
K = 208/230-1-60	L = 460-3-60																							
H = 208/230-3-60	S = 575-3-60																							
<table style="width: 100%; border: none;"> <tr> <td style="width: 50%;">D = Low Heat</td> <td style="width: 50%;">L = Low Heat, Low NO<sub>x</sub>*</td> </tr> <tr> <td>E = Medium Heat</td> <td>M = Medium Heat, Low NO<sub>x</sub>*</td> </tr> <tr> <td>F = High Heat</td> <td>N = High Heat, Low NO<sub>x</sub>*</td> </tr> </table> <p>S = Low Heat, Stainless Steel Heat Exchanger  R = Medium Heat, Stainless Steel Heat Exchanger  T = High Heat, Stainless Steel Heat Exchanger</p> <p style="text-align: right;"><b>Heating Capacity (See spec sheet for actual capacity)</b></p>															D = Low Heat	L = Low Heat, Low NO <sub>x</sub> *	E = Medium Heat	M = Medium Heat, Low NO <sub>x</sub> *	F = High Heat	N = High Heat, Low NO <sub>x</sub> *				
D = Low Heat	L = Low Heat, Low NO <sub>x</sub> *																							
E = Medium Heat	M = Medium Heat, Low NO <sub>x</sub> *																							
F = High Heat	N = High Heat, Low NO <sub>x</sub> *																							
<p>X = Direct drive ECM motor</p> <p>A = Standard Motor - (Belt Drive) (Not available on 3 - 5 ton)</p> <p>C = Medium Static Option (Belt Drive) (All 3 phase models)</p> <p>B = High Static Option (Belt Drive)(All 3 phase, 1 speed IFM except RGH150) (All 2 speed IFM models)</p> <p>E = High Static - High-Efficiency Motor (Belt Drive) (RGH150 with 1 speed IFM)</p> <p>G = High Static Motor with Hot Gas Re-Heat (Belt Drive) (1 speed IFM - RGH150 only)</p> <p>H = High Static Motor with Hot Gas Re-Heat (Belt Drive) (All sizes with 1 speed IFM except RGH110 &amp; 150) (All sizes with 2 speed IFM except RGH110)</p> <p style="text-align: right;"><b>Motor Option</b></p>																								
<p>A = None</p> <p>B = Economizer w/Barometric relief, OA Temp sensor</p> <p>E = Economizer w/Barometric relief + CO<sub>2</sub> Sensor, OA Temp sensor</p> <p>H = Enthalpy Economizer w/Barometric relief, enthalpy sensor</p> <p>L = Enthalpy Economizer w/Barometric relief + CO<sub>2</sub> Sensor, enthalpy sensor</p> <p>U = Temp Ultra Low Leak Economizer w/Barometric relief</p> <p>W = Enthalpy Ultra Low Leak Economizer w/Barometric relief</p> <p>P = 2-Position damper w/Baro-relief</p> <p style="text-align: right;"><b>Outdoor Air Options / Control (See spec sheet for details)</b></p>																								
<p>0A = Standard</p> <p>BB = Powered 115v Convenience Outlet</p> <p>AT = Non-powered 115v Convenience Outlet</p> <p>4B = Non-Fused Disconnect</p> <p>BR = Supply Air Smoke Detector</p> <p>AA = Easy Access Hinged Panels</p> <p style="text-align: right;"><b>Factory Installed Options (Not available on 1 phase models)</b></p>																								
<table style="width: 100%; border: none;"> <tr> <td style="width: 50%;">A = Aluminum / Copper Cond &amp; Alum/Copper Evap Coil</td> <td style="width: 50%;">D = E-Coated Alum/Cu Cond &amp; Evap</td> </tr> <tr> <td>B = Pre-coat Alum/Copper Cond &amp; Alum / Copper Evap (3 Phase only)</td> <td>E = Cu/Cu Cond &amp; Alum/Cu Evap</td> </tr> <tr> <td>C = E-Coated Alum/Copper Cond &amp; Alum / Copper Evap (3 Phase only)</td> <td>F = Copper/Copper Cond &amp; Evap</td> </tr> </table> <p style="text-align: right;"><b>Condenser / Evaporator Coil Configuration</b></p>															A = Aluminum / Copper Cond & Alum/Copper Evap Coil	D = E-Coated Alum/Cu Cond & Evap	B = Pre-coat Alum/Copper Cond & Alum / Copper Evap (3 Phase only)	E = Cu/Cu Cond & Alum/Cu Evap	C = E-Coated Alum/Copper Cond & Alum / Copper Evap (3 Phase only)	F = Copper/Copper Cond & Evap				
A = Aluminum / Copper Cond & Alum/Copper Evap Coil	D = E-Coated Alum/Cu Cond & Evap																							
B = Pre-coat Alum/Copper Cond & Alum / Copper Evap (3 Phase only)	E = Cu/Cu Cond & Alum/Cu Evap																							
C = E-Coated Alum/Copper Cond & Alum / Copper Evap (3 Phase only)	F = Copper/Copper Cond & Evap																							
<p>A = Standard Single Speed Indoor Fan Motor For W7212 controls</p> <p>B = Standard Single Speed Indoor Fan Motor For W7220 controls</p> <p>T = 2 Speed Indoor Fan VFD Controller (For 2-stage units only)</p> <p style="text-align: right;"><b>Motor Type Option</b></p>																								

\* RGH 3 to 5 ton models only

**NOTE:** On single phase (K voltage code) models, the following are not available as factory installed options:

- Coated or copper fin coils
- Economizers or 2 position dampers
- Hot Gas Re-heat

**Table 1 – FACTORY-INSTALLED OPTIONS AND FIELD-INSTALLED ACCESSORIES**

CATEGORY	ITEM	FACTORY-INSTALLED OPTION	FIELD-INSTALLED ACCESSORY
Cabinet	Thru-the-base electrical or gas-line connections		X
	Hinged access panels	X	
	Supply duct cover - 150 size only		X
Coil Options	Cu/Cu indoor and/or outdoor coils <sup>1</sup>	X	
	Pre-coated outdoor coils <sup>1</sup>	X	
	Premium, E-coated outdoor coils <sup>1</sup>	X	
Humidity Control	Hot Gas Re-Heat Adaptive Dehumidification System <sup>1</sup>	X	
Condenser Protection	Condenser coil hail guard (louvered design) <sup>1</sup>	X	X
Controls	Thermostats, temperature sensors, and subbases		X
	Smoke detector (supply and/or return air)	X	
	Horn/Strobe Annunciator <sup>7</sup>		X
	Time Guard II compressor delay control circuit		X
	Phase Monitor		X
	Condensate Overflow switch - for electro-mechanical controls only	X	X
Economizers & Outdoor Air Dampers	EconoMi\$er <sup>®</sup> IV for electro-mechanical controls - Non FDD (Standard air leak damper models) <sup>1, 6</sup>	X	X
	EconoMi\$er 2 for DDC controls (Standard and Ultra Low Leak air damper models) <sup>1</sup>	X	X
	Motorized 2 position outdoor-air damper <sup>1</sup>	X	X
	Manual outdoor-air damper (25% and 50%)	X	X
	Barometric relief <sup>2</sup>	X	X
	Power exhaust (prop design)		X
Economizer Sensors & IAQ Devices	EconoMi\$er X for electro-mechanical controls, complies with FDD. (Standard and Ultra Low Leak air damper models) <sup>1, 6</sup>	X	X
	Single dry bulb temperature sensors <sup>3</sup>	X	X
	Differential dry bulb temperature sensors <sup>3</sup>		X
	Single enthalpy sensors <sup>3</sup>	X	X
	Differential enthalpy sensors <sup>3</sup>		X
	Wall or duct mounted CO <sub>2</sub> sensor <sup>3</sup>		X
Gas Heat	Unit mounted CO <sub>2</sub> sensor <sup>3</sup>	X	
	Propane conversion kit		X
	Stainless steel heat exchanger	X	
	High altitude conversion kit		X
	Flue Shield (036-120 models only)		X
Indoor Motor & Drive	Flue Discharge Deflector		X
	Multiple motor and drive packages	X	
	2-Speed Indoor Fan Motor system w/VFD controller (2-stage cool only with electro-mechanical controls)	X	
Low Ambient Control	Display Kit for 2-Speed Indoor Fan Motor system with VFD		X
	Winter start kit <sup>4</sup>		X
	Motormaster <sup>®</sup> head pressure controller to -20°F <sup>4</sup>		X
Power Options	Cooling Low Ambient Controller to 0°F (except 110 size) <sup>4</sup>	X	
	Convenience outlet (powered) <sup>1,8</sup>	X	
	Convenience outlet (unpowered)	X	
Roof Curbs	Non-fused disconnect <sup>5</sup>	X	
	Roof curb 14-in (356mm)		X
	Roof curb 24-in (610mm)		X

**NOTES:**

- Not available as factory installed option on single phase (208/230-1-60) models. Use field-installed accessory where available.
- Included with economizer.
- Sensors used to optimize economizer performance.
- See application data for assistance.
- Non fused disconnect switch (036-120 sizes) cannot be used when unit electrical rating exceeds 80 amps (all voltages).  
Non fused disconnect switch (150 size) cannot be used when unit electrical rating exceeds 100 amps (all voltages).
- FDD - (Fault Detection and Diagnostic per California Title 24 section 120.2.
- Requires a field-supplied 24V transformer for each application. See price pages for details.
- Powered convenience outlet is not available on single phase models and 110 size models with 460 and 575 voltage.

## FACTORY OPTIONS AND/OR ACCESSORIES

### **Economizer (dry-bulb or enthalpy)**

Economizers can reduce operating costs. They bring in fresh, outside air for ventilation; and provide cool outside air to cool your building. This also is the preferred method of low ambient cooling. When coupled to CO<sub>2</sub> sensors, economizers can limit the ventilation air to only that amount required.

Economizers are available, installed and tested by the factory, with either enthalpy or temperature dry-bulb inputs. There are also models for electro-mechanical, direct digital controllers and single speed fan or 2-speed indoor fan motors. Additional sensors are available as accessories to optimize the economizer.

Economizers include gravity controlled barometric relief that helps equalize building pressure and ambient air pressures. This can be a cost effective solution to prevent building pressurization. Economizers are available in Ultra Low Leak and standard low leak versions.

### **CO<sub>2</sub> Sensor**

The CO<sub>2</sub> sensor works with the economizer to intake only the correct amount of outside air for ventilation. As occupants fill your building, the CO<sub>2</sub> sensor detects their presence through increasing CO<sub>2</sub> levels, and opens the economizer appropriately.

When the occupants leave, the CO<sub>2</sub> levels decrease, and the sensor appropriately closes the economizer. This intelligent control of the ventilation air, called Demand Controlled Ventilation (DCV) reduces the overall load on the rooftop, saving money.

### **Smoke Detectors**

Trust the experts. Smoke detectors make your application safer and your job easier. ICP smoke detectors immediately shut down the rooftop unit when smoke is detected. They are available, installed by the factory, for supply air, return air, or both.

### **Louvered Hail Guards**

Sleek, louvered panels protect the condenser coil from hail damage, foreign objects, and incidental contact.

### **Convenience Outlet (powered or un-powered)**

Reduce service and/or installation costs by including a convenience outlet in your specification. ICP will install this service feature at our factory. Provides a convenient, 15 amp, 115v GFCI receptacle with "Wet in Use" cover. The "powered" option allows the installer to power the outlet from the line side of the disconnect or load side as required by code. The "unpowered" option is to be powered from a separate 115/120v power source.

### **Non-fused Disconnect**

This OSHA-compliant, factory-installed, safety switch allows a service technician to locally secure power to the rooftop. When selecting a factory-installed non-fused disconnect, note they are sized for the unit as ordered from the factory. The sizing of these do not

accommodate field-installed items such as power exhaust devices, etc.

### **Power Exhaust with Barometric Relief**

Superior internal building pressure control. This field-installed accessory may eliminate the need for costly, external pressure control fans.

### **Time Guard II Control Circuit**

This accessory protects your compressor by preventing short-cycling in the event of some other failure, prevents the compressor from restarting for 30 seconds after stopping. Not required with authorized commercial thermostats.

### **Motorized 2-Position Damper**

The new ICP 2-position, motorized outdoor air damper admits up to 100% outside air. Using reliable, gear-driven technology, the 2-position damper opens to allow ventilation air and closes when the rooftop stops, stopping unwanted infiltration. Not available with 2-Speed Indoor Fan Motor models.

### **Manual OA Damper**

Manual outdoor air dampers are an economical way to bring in ventilation air. The dampers are available in 25% and 50% versions. Not available with 2-Speed Indoor Fan Motor models.

### **Optional Hot Gas Re-Heat Adaptive Dehumidification System**

ICP's Hot Gas Re-Heat adaptive dehumidification system is an all-inclusive factory installed option that can be ordered with any RGH036-150 rooftop unit, with the exception of single phase voltage (208-230/1/60) units.

This system expands the envelope of operation of ICP's rooftop products to provide unprecedented flexibility to meet year round comfort conditions.

The Hot Gas Re-Heat adaptive dehumidification system has the industry's only dual dehumidification mode setting. The Hot Gas Re-Heat system includes two new modes of operation.

The RGH036-150 rooftop coupled with the Hot Gas Re-Heat system is capable of operating in normal design cooling mode, subcooling mode, and hot gas reheat mode. Normal design cooling mode is when the unit will operate under its normal sequence of operation by cycling compressors to maintain comfort conditions.

Subcooling mode will operate to satisfy part load type conditions when the space requires combined sensible and a higher proportion of latent load control. Hot Gas Reheat mode will operate when outdoor temperatures diminish and the need for latent capacity is required for sole humidity control. Hot Gas Reheat mode will provide neutral air for maximum dehumidification operation.

## FACTORY OPTIONS AND/OR ACCESSORIES (cont)

### 2-Speed Indoor Fan Motor System

2-Speed Indoor Fan Motor system saves energy and installation time by utilizing a Variable Frequency Drive (VFD) to automatically adjust the indoor fan motor speed in sequence with the units cooling operation. Per ASHRAE 90.1-2013 standard section 6.4.3.10.b, during the first stage of cooling operation the VFD will adjust the fan motor to provide 66% of the total cfm established for the unit. When a call for the second stage of cooling is required, the VFD will allow the total cfm for the unit established (100%). During the heating mode the VFD will allow total design cfm (100%) operation and during the ventilation mode the VFD will allow operation to 66% of total cfm.

Compared to single speed indoor fan motor systems, 2-Speed Indoor Fan Motor system can save substantial energy, 25%+, versus single speed indoor fan motor systems.

**IMPORTANT:** Data based on .10 (\$/kWh) in an office application utilizing ICP's Rooftop Energy Savings Calculator simulation software program.

The VFD used in 2-Speed Indoor Fan Motor system has soft start capabilities to slowly ramp up the speeds, thus eliminating any high inrush air volume during initial start-up. It also has internal over current protection for the fan motor and a field installed display kit that allows adjustment and in depth diagnostics of the VFD.

This 2-Speed Indoor Fan Motor system is available on models with 2-stage cooling operation with electro-mechanical controls. Both space sensor and conventional thermostats controls can be used to provide accurate control in any application.

The 2-speed indoor fan motor system is very flexible for initial fan performance set up and adjustment. The standard factory shipped VFD is pre-programmed to automatically stage the fan speed between the first and second stage of cooling. The unit fan performance static pressure and cfm can be easily adjusted using the traditional means of pulley adjustments. The other means to adjust the unit static and cfm performance is to utilize the field installed Display Kit and adjust the frequency and voltage in the VFD to required performance requirements. In either case, once set up, the VFD will automatically adjust the speed between the cooling stage operations.

### Hinged Access Panels

Allows access to unit's major components with specifically designed hinged access panels. Panels are: filter, control box, fan motor and compressor.

### Motormaster® Head Pressure Controller

The Motormaster motor controller is a low ambient, head pressure controller kit that is designed to maintain the unit's condenser head pressure during periods of low ambient cooling operation. This device should be used as an alternative to economizer free cooling not when economizer usage is either not appropriate or desired. The Motormaster will either cycle the outdoor-fan motors or operate them at reduced speed to maintain the unit operation, depending on the model.

Motormaster allows cooling operation down to -20°F (-29°C) ambient conditions.

### Winter Start Kit

The winter start kit by ICP extends the low ambient limit of your rooftop to 25°F (-4°C). The kit bypasses the low pressure switch, preventing nuisance tripping of the low pressure switch. Other low ambient precautions may still be prudent.

### Propane Heating

Convert your gas heat rooftop from standard natural gas operation to Propane using this field-installed kit.

### High Altitude Heating

High altitudes have less oxygen, which means heat exchangers need less fuel. The new gas orifices in this field-installed kit make the necessary adjustment for high altitude applications. They significantly improve fuel to air mixture and maintain healthy combustion at altitudes above 2000 ft (610m). Kits may not be required in all areas.

### Flue Discharge Deflector

The flue discharge deflector is a useful accessory when flue gas recirculation is a concern. By venting the flue discharge upwards, the deflector minimizes the chance for a neighboring unit to intake the flue exhaust.

### Optional Stainless Steel Heat Exchanger

The stainless steel heat exchanger option provides the tubular heat exchanger be made out of a minimum 20 gauge type 409 stainless steel for applications where the mixed air to the heat exchanger is expected to drop below 45°F (7°C). Stainless steel may be specified on applications where the presence of airborne contaminants require its use (applications such as paper mills) or in area with very high outdoor humidity that may result in severe condensation in the heat exchanger during cooling operation.

## FACTORY OPTIONS AND/OR ACCESSORIES (cont)

### Flue Discharge Heat Shield

The flue discharge heat shield keeps people from touching the rooftop unit's potentially hot flue discharge. This is especially useful for ground level applications, where more, untrained people could have access to the unit's exterior (036-120 models only).

### Alternate Motors and Drives

Some applications need larger horsepower motors, some need more airflow, and some need both. Regardless of the case, your ICP expert has a factory installed combination to meet your application. A wide selection of motors and pulleys (drives) are available, factory installed, to handle nearly any application.

### Thru-the-Base Connections

Thru-the-base connections, available as an accessory, are necessary to ensure proper connection and seal when routing wire and piping through the rooftop's basepan and curb. These couplings eliminate roof penetration and should be considered for gas lines, main power lines, as well as control power.

### Low Ambient Controller

The low ambient controller is a head pressure controller kit that is designed to maintain the unit's condenser head pressure during periods of low ambient cooling operation. This device should be used as an alternative to economizer free cooling when economizer usage is either not appropriate or desired. The low ambient controller will either cycle the outdoor fan motors or operate them at reduced speed to maintain the unit operation, depending on the model. This controller allows cooling operation down to 0°F (-18°C) ambient conditions. (Not available on 110 size models as standard unit cooling operation down to 0°F /-18°C.)

### Condensate Overflow Switch (Factory-Installed Option)

This sensor and related controller monitors the condensate level in the drain pan and shuts down compression operation when overflow conditions occur. It includes:

- Indicator light – solid red (more than 10 seconds on water contact – compressors disabled), blinking red (sensor disconnected)
- 10 second delay to break – eliminates nuisance trips from splashing or waves in pan (sensor needs 10 seconds of constant water contact before tripping)
- Disables the compressor(s) operation when condensate plug is detected, but still allows fans to run for Economizer.

**NOTE:** The Condensate Overflow switch FIOP is only available for units with electro-mechanical controls.

## ACCESSORIES - RGH036-150

ECONOMIZERS		
VERTICAL		
Model Number	Description	Use With Model Size
CRECOMZR020A02	STANDARD LEAK Vertical EconoMi\$er® IV with solid-state controller, gear-driven, damper, spring return actuator, up to 100% barometric relief, supply and outdoor air temperature sensors, and CO <sub>2</sub> sensor compatible, for use in non-DDC applications.	036 - 060
CRECOMZR021A03	STANDARD LEAK Vertical EconoMi\$er IV with solid-state controller, gear-driven, modulating damper, spring return actuator, up to 100% barometric relief, supply and outdoor air temperature sensors, and CO <sub>2</sub> sensor compatible, for use in non-DDC applications.	072 - 120
CRECOMZR062A00	STANDARD LEAK Vertical EconoMi\$er IV with solid-state controller, gear-driven, modulating damper, spring return actuator, up to 100% barometric relief, supply and outdoor air temperature sensors, and CO <sub>2</sub> sensor compatible, for use in non-DDC applications.	150
CRECOMZR069A00 <sup>1,2</sup>	Ultra Low Leak Vertical EconoMi\$er X with solid-state W7220 controller, gear-driven, modulating damper, spring return actuator, up to 100% barometric relief, supply and outdoor air sensors, and CO <sub>2</sub> sensor compatible, for use in electro-mechanical controls only.	072 - 120
CRECOMZR071A00 <sup>1,2</sup>	Ultra Low Leak Vertical EconoMi\$er X with solid-state W7220 controller, gear-driven, modulating damper, spring return actuator, up to 100% barometric relief, supply and outdoor air sensors, and CO <sub>2</sub> sensor compatible, for use in electro-mechanical controls only.	150
HORIZONTAL		
Model Number	Description	Use With Model Size
CRECOMZR024A02	STANDARD LEAK Horizontal EconoMi\$er IV with solid-state controller, gear-driven, modulating damper, spring return actuator, up to 100% barometric relief, supply and outdoor air temperature sensors, and CO <sub>2</sub> sensor compatible, for use in non-DDC applications.	036 - 060
CRECOMZR025A02	STANDARD LEAK Horizontal EconoMi\$er IV with solid-state controller, gear-driven, modulating damper, spring return actuator, up to 100% barometric relief, supply and outdoor air temperature sensors, and CO <sub>2</sub> sensor compatible, for use in non-DDC applications.	072 - 120
CRECOMZR064A00	STANDARD LEAK Horizontal EconoMi\$er IV with solid-state controller, gear-driven, modulating damper, spring return actuator, up to 100% barometric relief, supply and outdoor air temperature sensors, and CO <sub>2</sub> sensor compatible, for use in non-DDC applications.	150

<sup>1</sup> EconoMi\$er IV cannot be installed with an EconoMi\$er X, Manual Damper, or Motorized Damper.

<sup>2</sup> When installed on a unit with hinged panels, hinged panel access kit is also required.

## ACCESSORIES - RGH036-150 (cont)

<b>POWER EXHAUST *</b>		
<b>Model Number</b>	<b>Description</b>	<b>Use With Model Size</b>
CRPWREXH030A01	Vertical Power Exhaust 208/230 volt (1 or 3 Phase)	036 - 060
CRPWREXH021A01	Vertical Power Exhaust 460 volt	036 - 060
CRPWREXH022A01	Vertical Power Exhaust 208/230-3-60 volt	072 - 120
CRPWREXH023A01	Vertical Power Exhaust 460 volt	072 - 120
CRPWREXH080A00	Vertical Power Exhaust 208/230-3-60 volt	150
CRPWREXH081A00	Vertical Power Exhaust 460 volt	150
CRPWREXH028A01	Horizontal Power Exhaust 208/230 (1 or 3 Phase) & 575 volt	036 - 120
CRPWREXH029A01	Horizontal Power Exhaust 460 volt	036 - 120
CRPWREXH082A00	Horizontal Power Exhaust 208/230 & 575 volt	150
CRPWREXH083A00	Horizontal Power Exhaust 460 volt	150

\* Vertical Power Exhaust requires a vertical economizer. Horizontal Power Exhaust should be duct-mounted in the return duct.

<b>MANUAL OUTDOOR AIR DAMPERS</b>		
<b>Model Number</b>	<b>Description</b>	<b>Use With Model Size</b>
CRMANDPR001A03	25% Open Manual Fresh Air Damper	036 - 060
CRMANDPR001A02	50% Open Manual Fresh Air Damper	036 - 060
CRMANDPR002A03	25% Open Manual Fresh Air Damper	072 - 120
CRMANDPR002A02	50% Open Manual Fresh Air Damper	072 - 120
CRMANDPR011A00	50% Open Manual Fresh Air Damper	150
<b>MOTORIZED OUTDOOR AIR DAMPERS</b>		
<b>Model Number</b>	<b>Description</b>	<b>Use With Model Size</b>
CRTWOPOS010A00	Motorized 2 position outdoor air damper (25-100% Outdoor Air)	036 - 060
CRTWOPOS011A00		072 - 120
CRTWOPOS014A00		150

**NOTES:**

1. EconoMiSer® IV, EconoMiSer X, Manual Damper and 2-Position damper are all mutually exclusive and cannot be installed together.
2. Manual dampers include hood assembly, bird screen, adjustable damper blade (to allow up to the rated outdoor air %), and bottom panel with opening.
3. Motorized dampers include bottom panel with opening (100% two-position damper includes 30% barometric relief capability), and adjustable damper (to allow up to the rated outdoor air %)
4. Motorized dampers will close on loss of power to the rooftop unit.  
Manual and motorized dampers are not compatible with a vertical power exhaust module.

## ACCESSORIES - RGH036-150 (cont)

LOW AMBIENT CONTROLS *		
Model Number	Description	Use With Model Size
32LT900301 <sup>1</sup>	Motormaster® I -20°F (-29°C) Low Ambient Control	036 - 102, 208/230-1-60, 208/203-3-60, 575-3-60
32LT900611 <sup>1</sup>	Motormaster I -20°F (-29°C) Low Ambient Control	048 - 102, 460-3-60
CPLOWAMB001A00	Motormaster II -0°F (-18°C) Low Ambient Control	036 - 150, 208/230-1, 208/230-3, 460-3-60
1178185 <sup>2</sup>	Motormaster I Compatible Condenser Fan Motor	036, 208/230-3-60, 575-3-60
1178186 <sup>2</sup>	Motormaster I Compatible Condenser Fan Motor	036, 460-3-60
1171974 <sup>2</sup>	Motormaster I Compatible Condenser Fan Motor	048 - 102, 208/230-3-60, 575-3-60
1171975 <sup>2</sup>	Motormaster I Compatible Condenser Fan Motor	048 - 102, 460-3-60
CRLOWAMB030A00 <sup>3</sup>	Motormaster V Low Ambient Control Mechanical cooling operation down to -20°F (-29°C)	120, 208/230-3-60
CRLOWAMB031A00 <sup>3</sup>		120, 460-3-60
CRLOWAMB032A00 <sup>3</sup>		120, 575-3-60
CRLOWAMB039A00	Motormaster I Low Ambient Kit. Mechanical cooling operation down to -20° F (- 29° C). Kit includes 3 motors, Motormaster controller, wiring label, and required wire ties and connectors, CRWINSTR001A00 also required (one per refrigerant circuit)	150, 208/230-3-60
CRLOWAMB040A00	Motormaster I Low Ambient Kit. Mechanical cooling operation down to -20° F (- 29° C). Kit includes 3 motors, Motormaster controller, wiring label, and required wire ties and connectors) 575 Volt models also require CRTRXKIT002A00 plus CRWINSTR001A00 also required (one per refrigerant circuit).	150, 460-3-60
CRTRXKIT002A00	Motormaster I Low Ambient Control - Transformer Kit. Must be used in conjunction with Low Ambient Controller if used on 575-3-60 volt models.	150, 575-3-60

\*See usage tables in kit instructions.

<sup>1</sup> Requires motor change out.

<sup>2</sup> Available from FAST Parts.

Note: Sizes 036-060 requires (1) low ambient controller and (1) compatible condenser fan motor for change out

Sizes 072-102 requires (1) low ambient controller and (2) compatible condenser fan motors for change out

<sup>3</sup> No motor change is required on these specific models. Requires two CRWINSTR001A00 Winter Start kits (one per circuit).

FLAT ROOF CURBS		
Model Number	Description	Use With Model Size
CRRFCURB001A01	14" High Roof Curb. Ductwork attaches to the roof curb. Includes thru-the-bottom capability.	036 - 060
CRRFCURB003A01		072 - 120
CRRFCURB074A00		150
CRRFCURB002A01	24" High Roof Curb. Ductwork attaches to the roof curb. Includes thru-the-bottom capability.	036 - 060
CRRFCURB004A01		072 - 120
CRRFCURB075A00		150
ACCESSORY KITS FOR UNITS WITH HINGED ACCESS PANELS		
Model Number	Description	Use With Model Size
CRHNGPNL001A00	Horizontal accessory kit. Required when field installing a two position damper or vertical economizer. Includes angle and seal strip.	036 - 060
CRHNGPNL002A00		072 - 120
CRPECONV003A00	Vertical accessory kit. Required when field installing a two position damper or vertical economizer. Includes door panel, angle and seal strip	036 - 060
CRPECONV004A00		072 - 120
LOUVERED HAIL GUARDS - CONDENSER COIL		
Model Number	Description	Use With Model Size
CRLVHLGD012A00	Louvered Condenser Coil Hail Guard	036
CRLVHLGD013A00	Louvered Condenser Coil Hail Guard	048 - 060
CRLVHLGD014A00	Louvered Condenser Coil Hail Guard	072 - 073
CRLVHLGD016A00	Louvered Condenser Coil Hail Guard	090 - 120
CRLVHLGD032A00	Louvered Condenser Coil Hail Guard	150

## ACCESSORIES - RGH036-150 (cont)

575V TRANSFORMER		
Model Number	Description	Use With Model Size
1171494 <sup>2</sup>	Transformer for conversion from 575v to 208/230v power exhaust applications.	036 - 150
SPECIAL - 150 SIZE SPECIFIC ACCESSORIES		
Model Number	Description	Use With Model Size
CRDISBKT001A00	Disconnect Switch Bracket - Provides a pre engineered and sized mounting bracket for applications requiring a unit mounted fused and non-fused disconnect of greater than 100 amps. Bracket assures that no damage will occur to coils when mounting with screws and other fasteners.	150
CRDUCTCV002A00	Supply Duct Cover - This supply duct cover is required when field converting the factory standard vertical duct supply to horizontal duct supply configuration. One required per unit.	150
CONTROL UPGRADE KITS		
Model Number	Description	Use With Model Size
CRDISKIT001A00	2-Speed VFD display kit provides the field capability to set up points and troubleshooting codes on the VFD controller. Can be used for any associated unit with VFD.	All 2-Speed VFD Controllers
CRTIMEGD001A00	Time Guard II	036 - 150
CRWINSTR001A00	Winter Start Kit - Electronic phase monitor breaks "R" control signal if trouble is detected. (Allows operation down to 25°F from standard 40°F.)	036 - 150
CRPHASE3001A02	Phase Monitor Control	All 208/230v, 460v (3 Ph only)
CRPHASE3002A00	Phase Monitor Control	All 575v
CRSTATUS001A02	Fan/Filter Status Switch	036 - 150
CRSDTEST001A00	Remote keyed attenuator / test / reset station	036 - 150

<sup>2</sup> Available from FAST Parts.

THROUGH-THE-BOTTOM/CURB POWER CONNECTION		
Model Number	Description	Use With Model Size
CRBTMPWR001A01	Thru-the-bottom electrical connections and thru-the-curb gas connections. Includes a 3/4-inch diameter liquid tight conduit fitting for high voltage power wires	036 - 060
CRBTMPWR002A01	Thru-the-bottom electrical connections and thru-the-curb gas connections. Includes a 1-1/4-inch diameter liquid tight conduit fitting for high voltage power wires	072 - 120
CRBTMPWR003A01	Thru-the-bottom power, control, and gas connections. Includes a 3/4-inch diameter liquid tight conduit fitting for high voltage power wires	036 - 060
CRBTMPWR004A01	Thru-the-bottom power, control, and gas connections. Includes a 1-1/4-inch diameter liquid tight conduit fitting for high voltage power wires	072 - 120
CRBTMPWR005A00	Thru-the-bottom power, control, and gas connections. Includes a 1-1/4 inch diameter liquid tight conduit fitting for high voltage power wires	150
CRBTMPWR006A00	Thru-the-bottom power, control, and gas connections. Includes a 1-1/2 inch diameter liquid tight conduit fitting for high voltage power wires	
CRBTMPWR007A00	Thru-the-bottom power, control, and gas connections. Includes a 2 inch diameter liquid tight conduit fitting for high voltage power wires	

ECONOMIZER SENSORS		
Model Number	Description	Use With Economizer
CRTEMPSN002A00	Outdoor or Return Dry Bulb Sensor used with electro-mechanical controls	EconoMi\$er <sup>®</sup> IV
CRCBDIOX005A00	CO <sub>2</sub> Sensor for use in return airstream. Also includes Aspirator Box required for Duct Mounting.	EconoMi\$er IV & EconoMi\$er X
CRENTDIF004A00	Return Air Enthalpy Sensor used with electro-mechanical controls, use with --HH--57AC-078 for differential enthalpy control	EconoMi\$er IV
--HH--57AC-078	Economizer Differential Enthalpy Control Upgrade	EconoMi\$er IV
CRTEMPSN005A00	Outdoor or Return Dry Bulb Temperature Sensor used with Honeywell W7220 electro-mechanical control.	EconoMi\$er X
--HH--57AC-081	Enthalpy Control for W7220 Controller only, (One required for single enthalpy, two required for different enthalpy)	EconoMi\$er X

## ACCESSORIES - RGH036-150 (cont)

LP GAS CONVERSION KITS		
Model Number	Description	Use With Model Size
CRLPELEV001A00	LP and Hi Altitude conversion kit. Contains spuds sizes 31, 32, 33, 35, and 36.	036 - 120
CRLPELEV002A00	LP and Hi Altitude conversion kit. Contains spuds sizes 37, 38, 39, 44, and 45.	036 - 120
CRLPELEV003A00	LP and Hi Altitude conversion kit. Contains spuds sizes 46, 47, 48, 49, and 50.	036 - 120
CRLPELEV004A00	LP and Hi Altitude conversion kit. Contains spuds sizes 51, 52, 53, 54, and 55.	036 - 120
CRLPELEV007A00	LP and Hi Altitude conversion kit. Contains spuds sizes 36, 37, 38, and 39.	150
CRLPELEV008A00	LP and Hi Altitude conversion kit. Contains spuds sizes 40, 41, 42, and 43.	150
CRLPELEV009A00	LP and Hi Altitude conversion kit. Contains spuds sizes 51, 52, 53, 54, and 55.	150
HEATING UPGRADE KITS*		
Model Number	Description	Use With Model Size
CRFLUEDS001A00	Flue Discharge Deflector	036 - 120
CRFLUEHD001A01	Flue Exhaust Heat Shield	036 - 120
CRFLUEDS007A00	Flue Discharge Deflector	150

\*CRFLUEDS001A00 and CRFLUEHD001A01 are mutually exclusive. Cannot install both on the same unit.

**Table 2 – AHRI COOLING RATING TABLE 1-STAGE COOLING**

RGH Unit Size	Cooling Stages	Nom. Capacity (tons)	Net Cooling Capacity (MBH)	Total Power (kW)	SEER	EER	IEER
036	1	3	36.0	2.9	15.00	12.50	-
048	1	4	48.5	3.7	15.60	13.00	-
060	1	5	57.5	4.6	15.20	12.45	-
072	1	6	73.0	6.0	-	12.00	13.00

**Table 3 – AHRI COOLING RATING TABLE 2-STAGE COOLING**

RGH Unit Size	Cooling Stages	Nom. Capacity (tons)	Net Cooling Capacity (MBH)	Total Power (kW)	EER	IEER WITH SINGLE SPEED INDOOR MOTOR	IEER WITH 2-SPEED INDOOR MOTOR
073	2	6.0	72.0	6.0	12.0	14.0	16.0
090	2	7.5	89.0	7.4	12.0	13.0	13.8
102	2	8.5	97.0	8.1	12.0	13.0	13.8
110	2	10.0	111.0	9.3	12.0	12.6	14.3
→ 120	2	10.0	115.0	10.0	11.5	12.0	12.7
150	2	12.5	146.0	11.9	12.2	13.0	13.9

**LEGEND AND NOTES FOR TABLES 2 AND 3**

**LEGEND**

- - Not Applicable
- AHRI - Air-Conditioning, Heating and Refrigeration Institute Test Standard
- ASHRAE - American Society of Heating, Refrigerating and Air-Conditioning Engineers
- EER - Energy Efficiency Ratio
- IEER - Integrated Energy Efficiency Ratio
- SEER - Seasonal Energy Efficiency Ratio

**NOTES:**

1. Rated in accordance with AHRI Standards 210/240 (036-060 size) and 340/360 (072-150 size).
2. Ratings are based on:  
Cooling Standard: 80°F (27°C) db, 67°F (19°C) wb indoor air temp and 95°F (35°C) db outdoor air temp.  
IEER Standard: A measure that expresses cooling part-load EER efficiency for commercial unitary air-conditioning and heat pump equipment on the basis of weighted operation at various load capacities.
3. All RGH units comply with ASHRAE 90.1-2013 and ENERGY STAR\* Energy Standard for minimum SEER and EER requirements.
4. RGH units comply with US Energy Policy Act (2005). To evaluate code compliance requirements, refer to state and local codes.



Use of the AHRI Certified TM Mark indicates a manufacturer's participation in the program. For verification of certification for individual products, go to [www.ahridirectory.org](http://www.ahridirectory.org).



or



Intertek



\* ENERGY STAR is a registered trademark of the U.S. Environmental Protection Agency.

**Table 4 – HEATING RATING TABLE - NATURAL GAS & PROPANE**

RGH UNIT SIZE	GAS HEAT	AL/SS HEAT EXCHANGER		TEMP RISE (DEG F)	THERMAL EFFICIENCY (%)	AFUE (%)	
		INPUT / OUTPUT STAGE 1 (MBH)	INPUT / OUTPUT STAGE 2 (MBH)				
Single Phase	036	LOW	-	65 / 53	25 - 55	82%	81%
		MED	-	90 / 73.5	45 - 85	82%	81.2%
		HIGH	-	-	-	-	-
	048	LOW	-	65 / 53	20 - 55	82%	81%
		MED	-	90 / 73.5	30 - 65	82%	81.2%
		HIGH	-	130 / 106	45 - 80	82%	81%
	060	LOW	-	65 / 53	15 - 55	82%	81%
		MED	-	90 / 73.5	25 - 65	82%	81.2%
		HIGH	-	130 / 106	35 - 80	82%	81%
Three Phase	036	LOW	50 / 41	72 / 59	25 - 55	82%	-
		MED	82 / 66	115 / 93	55 - 85	81%	-
		HIGH	-	-	-	-	-
	048	LOW	50 / 41	72 / 59	25 - 55	82%	-
		MED	82 / 66	115 / 93	35 - 65	81%	-
		HIGH	120 / 96	150 / 120	50 - 80	80%	-
	060	LOW	50 / 41	72 / 59	20 - 55	82%	-
		MED	82 / 66	115 / 93	30 - 65	81%	-
		HIGH	120 / 96	150 / 120	40 - 80	80%	-
	072 073	LOW	50 / 41	72 / 59	15 - 55	82%	-
		MED	90 / 73	125 / 103	20 - 50	82%	-
		HIGH	105 / 84	150 / 120	30 - 60	81%	-
	090	LOW	90 / 73	125 / 103	20 - 50	82%	-
		MED	120 / 98	180 / 148	35 - 65	82%	-
		HIGH	180 / 147	224 / 184	45 - 75	82%	-
	102	LOW	90 / 73	125 / 103	20 - 50	82%	-
		MED	120 / 98	180 / 148	30 - 65	82%	-
		HIGH	180 / 147	224 / 184	40 - 75	82%	-
	110	LOW	120 / 98	180 / 148	25 - 65	82%	-
		MED	180 / 147	224 / 184	30 - 65	82%	-
		HIGH	200 / 160	250 / 205	35 - 70	80%	-
120	LOW	120 / 98	180 / 148	25 - 65	82%	-	
	MED	180 / 147	224 / 184	30 - 65	82%	-	
	HIGH	200 / 160	250 / 205	35 - 70	80%	-	
150	LOW	120 / 96	150 / 120	15 - 60	80%	-	
	MED	144 / 118	180 / 146	20 - 55	81%	-	
	HIGH	192 / 156	240 / 195	25 - 60	81%	-	

- Not Applicable

**NOTES:**

- Heat ratings are for natural gas heat exchangers operated at or below 2000 ft (610 m). For information on Propane or altitudes above 2000 ft (610 m), see the Application Data section of this book. Accessory Propane/High Altitude kits are also available.
- In the USA the input rating for altitudes above 2000 ft (610 m) must be derated by 4% for each 1000 ft (305 m) above sea level.

**Table 5 – HEATING RATING TABLE - LOW NO<sub>x</sub><sup>1</sup>**

RGH UNIT SIZE	GAS HEAT	LOW NO <sub>x</sub> HEAT EXCHANGER	TEMP RISE (DEG F)	THERMAL EFFICIENCY (%)	AFUE (%)	
		INPUT / OUTPUT STAGE 1 (MBH)				
Single Phase	036	LOW	60 / 49	20 - 50	81%	81%
		MED	90 / 73.5	30 - 60	81%	81.2%
		HIGH	-	-	-	-
	048	LOW	60 / 49	20 - 50	81%	80.6%
		MED	90 / 73.5	30 - 60	81%	80.6%
		HIGH	120 / 98	40 - 70	81%	81.5%
	060	LOW	60 / 49	15 - 50	81%	80.6%
		MED	90 / 73.5	25 - 60	80%	80.6%
		HIGH	120 / 98	35 - 70	80%	81.5%
Three Phase	036	LOW	60 / 49	20 - 50	81%	-
		MED	90 / 73.5	30 - 60	81%	-
		HIGH	-	-	-	-
	048	LOW	60 / 49	20 - 50	81%	-
		MED	90 / 73.5	30 - 60	81%	-
		HIGH	120 / 98	40 - 70	81%	-
	060	LOW	60 / 49	15 - 50	81%	-
		MED	90 / 73.5	25 - 60	80%	-
		HIGH	120 / 98	35 - 70	80%	-

- Not Applicable

**NOTE:**

1. Units meet California's South Coast Air Quality Management District (SCAQMD) Low-NO<sub>x</sub> emissions requirement of 40 nanograms per joule or less.

**Table 6 – SOUND PERFORMANCE TABLE**

RGH UNIT SIZE	COOLING STAGES	OUTDOOR SOUND (dB) AT 60HZ								
		A-WEIGHTED	63	125	250	500	1000	2000	4000	8000
036	1	76	78.2	78.0	74.2	73.3	70.6	66.0	62.4	56.9
048	1	78	84.7	83.6	77.1	74.6	72.3	68.3	64.7	60.9
060	1	77	87.5	82.5	76.1	73.6	71.3	67.1	64.1	60.0
072	1	82	90.1	82.6	81.0	79.4	77.0	73.0	70.4	66.7
073	2	82	90.1	82.6	81.0	79.4	77.0	73.0	70.4	66.7
090	2	82	90.6	84.3	80.2	79.3	77.1	72.2	67.4	63.7
102	2	82	88.6	85.0	81.6	79.5	77.4	74.1	71.0	66.3
110	2	87	85.9	87.9	85.6	84.4	82.8	78.5	74.9	72.5
120	2	87	85.9	87.9	85.6	84.4	82.8	78.5	74.9	72.5
150	2	83	89.3	86.0	82.9	80.7	78.5	73.6	69.6	64.5

**LEGEND**

dB - Decibel

**NOTES:**

1. Outdoor sound data is measure in accordance with AHRI.
2. Measurements are expressed in terms of sound power. Do not compare these values to sound pressure values because sound pressure depends on specific environmental factors which normally do not match individual applications. Sound power values are independent of the environment and therefore more accurate.
3. A-weighted sound ratings filter out very high and very low frequencies, to better approximate the response of "average" human ear. A-weighted measurements for ICP units are taken in accordance with AHRI.

**Table 7 – MINIMUM - MAXIMUM AIRFLOW RATINGS (CFM) - NATURAL GAS & PROPANE\***

Unit	Heat Level	Voltage Type	Cooling				Heating	
			Minimum Single Speed Fan Motor	Minimum 2-speed Fan Motor (at high speed)	Minimum 2-speed Fan Motor (at low speed)	Maximum	Minimum	Maximum
RGH036	LOW	1 Phase	900	-	-	1500	900	1970
	MED						800	1520
	HIGH						-	-
RGH048	LOW	1 Phase	1200	-	-	2000	900	2470
	MED						1050	2280
	HIGH						1230	2190
RGH060	LOW	1 Phase	1500	-	-	2500	900	3290
	MED						1050	2730
	HIGH						1230	2820
RGH036	LOW	3 Phase	900	-	-	1500	990	2190
	MED						1000	1550
	HIGH						-	-
RGH048	LOW	3 Phase	1200	-	-	2000	990	2190
	MED						1330	2460
	HIGH						1390	2220
RGH060	LOW	3 Phase	1500	-	-	2500	990	2730
	MED						1330	2880
	HIGH						1390	2780
RGH072 RGH073	LOW	All	1800	1800	1200	3000	990	3640
	MED						1330	4750
	HIGH						1390	3750
RGH090	LOW	All	2250	2535	1673	3750	1900	4750
	MED						2100	3900
	HIGH						2270	3780
RGH102	LOW	All	2550	2550	1683	4250	1900	4750
	MED						2100	4560
	HIGH						2270	4250
RGH110	LOW	All	3000	3380	2231	5000	1900	4750
	MED						2100	4560
	HIGH						2270	4250
RGH120	LOW	All	3000	3380	2231	5000	2100	5470
	MED						2620	5670
	HIGH						2650	5290
RGH150	LOW	All	3750	4225	2789	6250	1880	7500
	MED						2450	6750
	HIGH						3000	7200

- Not available

\* Heating rating values are identical for aluminum heat exchangers and stainless steel heat exchangers.

**Table 8 – PHYSICAL DATA**

**(COOLING)**

**3 – 6 TONS**

		RGH036	RGH048	RGH060	RGH072	RGH073
<b>Refrigeration System</b>						
# Circuits / # Comp. / Type		1 / 1 / Scroll	1 / 1 / Scroll	1 / 1 / Scroll	1 / 1 / 1-Stage Scroll	1 / 1 / 2-Stage Scroll
R-410A refrigerant charge (lbs-oz)		9 - 0	12 - 8	13 - 3	14 - 0	14 - 0
Hot Gas Re-Heat R-410A refrigerant charge (lbs-oz)		11 - 0	19 - 12	20 - 0	22 - 8	22 - 8
Metering Device		TXV	TXV	TXV	TXV	TXV
High-press. Trip / Reset (psig)		630 / 505	630 / 505	630 / 505	630 / 505	630 / 505
Low-press. Trip / Reset (psig)		54 / 117	54 / 117	54 / 117	54 / 117	54 / 117
<b>Evap. Coil</b>						
Material (Tube Fin)		Cu / Al	Cu / Al	Cu / Al	Cu / Al	Cu / Al
Coil type		3/8-in RTPF	3/8-in RTPF	3/8-in RTPF	3/8-in RTPF	3/8-in RTPF
Rows / FPI		3 / 15	3 / 15	4 / 15	3 / 15	3 / 15
Total Face Area (ft <sup>2</sup> )		5.5	7.3	7.3	8.9	8.9
Condensate Drain Conn. Size		3/4-in	3/4-in	3/4-in	3/4-in	3/4-in
<b>Hot Gas Re-Heat Coil</b>						
Material (Tube Fin)		Cu / Al	Cu / Al	Cu / Al	Cu / Al	Cu / Al
Coil type		3/8-in RTPF	3/8-in RTPF	3/8-in RTPF	3/8-in RTPF	3/8-in RTPF
Rows / FPI		1 / 17	2 / 17	2 / 17	2 / 17	2 / 17
Total Face Area (ft <sup>2</sup> )		3.9	5.2	5.2	5.2	5.2
<b>Evap. Fan and Motor</b>						
Standard Static 1 phase	Motor Qty / Drive Type	1 / Direct	1 / Direct	1 / Direct	-	-
	Max BHP	1.0	1.0	1.0	-	-
	RPM Range	600-1200	600-1200	600-1200	-	-
	Motor Frame Size	48	48	48	-	-
	Fan Qty / Type	1 / Centrifugal	1 / Centrifugal	1 / Centrifugal	-	-
	Fan Diameter (in)	10 x 10	10 x 10	10 x 10	-	-
Standard Static 3 phase	Motor Qty / Drive Type	1 / Direct	1 / Direct	1 / Direct	1 / Belt	1 / Belt
	Max BHP	1.0	1.0	1.0	1.7	1.7
	RPM Range	600-1200	600-1200	600-1200	489-747	489-747
	Motor Frame Size	48	48	48	56	56
	Fan Qty / Type	1 / Centrifugal	1 / Centrifugal	1 / Centrifugal	1 / Centrifugal	1 / Centrifugal
	Fan Diameter (in)	10 x 10	10 x 10	11 x 10	15 x 15	15 x 15
Standard Static 3 phase*	Motor Qty / Drive Type	1 / Belt	1 / Belt	1 / Belt	1 / Belt	1 / Belt
	Max BHP	1.7	1.7	1.7	1.7	1.7
	RPM Range	560-854	560-854	770-1175	489-747	489-747
	Motor Frame Size	48	48	48	56	56
	Fan Qty / Type	1 / Centrifugal	1 / Centrifugal	1 / Centrifugal	1 / Centrifugal	1 / Centrifugal
	Fan Diameter (in)	10 x 10	10 x 10	10 x 10	15 x 15	15 x 15

\* Hot Gas Re-Heat models only

- Not Applicable

**Table 8 (cont) - PHYSICAL DATA**

**(COOLING)**

**3 - 6 TONS**

		RGH036	RGH048	RGH060	RGH072	RGH073
Evap. Fan and Motor						
Medium Static 3 phase	Motor Qty / Drive Type	1 / Belt	1 / Belt	1 / Belt	1 / Belt	1 / Belt
	Max BHP	1.7	1.7	2.4	2.9	2.9
	RPM Range	770-1175	920-1303	1035-1466	733-949	733-949
	Motor Frame Size	48	56	56	56	56
	Fan Qty / Type	1 / Centrifugal	1 / Centrifugal	1 / Centrifugal	1 / Centrifugal	1 / Centrifugal
	Fan Diameter (in)	10 x 10	10 x 10	10 x 10	15 x 15	15 x 15
Medium Static 3 phase*	Motor Qty / Drive Type	1 / Belt	1 / Belt	1 / Belt	1 / Belt	1 / Belt
	Max BHP	1.7	1.7	2.4	2.9	2.9
	RPM Range	770-1175	770-1175	1035-1466	733-949	733-949
	Motor Frame Size	48	48	56	56	56
	Fan Qty / Type	1 / Centrifugal	1 / Centrifugal	1 / Centrifugal	1 / Centrifugal	1 / Centrifugal
	Fan Diameter (in)	10 x 10	10 x 10	10 x 10	15 x 15	15 x 15
High Static 3 phase	Motor Qty / Drive Type	1 / Belt	1 / Belt	1 / Belt	1 / Belt	1 / Belt
	Max BHP	2.4	2.9	2.9	4.7	4.7
	RPM Range	1035-1466	1208-1639	1303-1687	909-1102	909-1102
	Motor Frame Size	56	56	56	14	14
	Fan Qty / Type	1 / Centrifugal	1 / Centrifugal	1 / Centrifugal	1 / Centrifugal	1 / Centrifugal
	Fan Diameter (in)	10 x 10	10 x 10	10 x 10	15 x 15	15 x 15
Condenser Coil						
	Material (Tube/Fin)	Cu / Al	Cu / Al	Cu / Al	Cu / Al	Cu / Al
	Coil type	3/8-in RTPF	3/8-in RTPF	3/8-in RTPF	3/8-in RTPF	3/8-in RTPF
	Rows / FPI	2 / 17	2 / 17	2 / 17	2 / 17	2 / 17
	Total Face Area (ft <sup>2</sup> )	12.7	21.3	21.3	20.5	20.5
Condenser fan / motor						
	Qty / Motor Drive Type	1/ Direct	1/ Direct	1/ Direct	2/ Direct	2/ Direct
	Motor HP / RPM	1/8 / 825	1/4 / 1100	1/4 / 1100	1/4 / 1100	1/4 / 1100
	Fan diameter (in)	22	22	22	22	22
Filters						
	RA Filter # / Size (in)	2 / 16 x 25 x 2	4 / 16 x 16 x 2	4 / 16 x 16 x 2	4 / 16 x 20 x 2	4 / 16 x 20 x 2
	OA inlet screen # / Size (in)	1 / 20 x 24 x 1	1 / 20 x 24 x 1	1 / 20 x 24 x 1	1 / 20 x 36 x 1	1 / 20 x 36 x 1

\* Hot Gas Re-Heat models only

**Table 9 – PHYSICAL DATA**

**(HEATING)**

**3 - 6 TONS**

		RGH036	RGH048	RGH060	RGH072 / RGH073
Gas Connection					
	# of Gas Valves	1	1	1	1
	Nat. gas supply line press (in. w.g.)/(PSIG)	4 - 13 / 0.18 - 0.47	4 - 13 / 0.18 - 0.47	4 - 13 / 0.18 - 0.47	4 - 13 / 0.18 - 0.47
	Propane supply line press (in. w.g.)/(PSIG)	11 - 13 / 0.40 - 0.47	11 - 13 / 0.40 - 0.47	11 - 13 / 0.40 - 0.47	11 - 13 / 0.40 - 0.47
Heat Anticipator Setting (Amps)					
	1st stage	0.14	0.14	0.14	0.14
	2nd stage	0.14	0.14	0.14	0.14
Natural Gas, Propane Heat					
LOW	# of stages / # of burners (total)	1 or 2 / 2	1 or 2 / 2	1 or 2 / 2	2 / 2
	Connection size	1/2-in NPT	1/2-in NPT	1/2-in NPT	1/2-in NPT
	Rollout switch opens / closes (F)	195 / 115	195 / 115	195 / 115	195 / 115
	Temperature rise range (F)	25 - 55	25 - 55	20 - 55	15 - 55
MED	# of stages / # of burners (total)	1 or 2 / 3	1 or 2 / 3	1 or 2 / 3	2 / 3
	Connection size	1/2-in NPT	1/2-in NPT	1/2-in NPT	1/2-in NPT
	Rollout switch opens / closes (F)	195 / 115	195 / 115	195 / 115	195 / 115
	Temperature rise range (F)	55 - 85	35 - 65	30 - 65	20 - 50
HIGH	# of stages / # of burners (total)	-	1 or 2 / 3	1 or 2 / 3	2 / 4
	Connection size	-	1/2-in NPT	1/2-in NPT	3/4-in NPT
	Rollout switch opens / closes (F)	-	195 / 115	195 / 115	195 / 115
	Temperature rise range (F)	-	50 - 80	40 - 80	30 - 60
Low NO <sub>x</sub> Gas Heat					
LOW	# of stages / # of burners (total)	1 / 2	1 / 2	1 / 2	-
	Connection size	1/2-in NPT	1/2-in NPT	1/2-in NPT	-
	Rollout switch opens / closes (F)	195 / 115	195 / 115	195 / 115	-
	Temperature rise range (F)	20 - 50	20 - 50	15 - 50	-
MED	# of stages / # of burners (total)	1 / 3	1 / 3	1 / 3	-
	Connection size	1/2-in NPT	1/2-in NPT	1/2-in NPT	-
	Rollout switch opens / closes (F)	195 / 115	195 / 115	195 / 115	-
	Temperature rise range (F)	30 - 60	30 - 60	25 - 60	-
HIGH	# of stages / # of burners (total)	-	1 / 3	1 / 3	-
	Connection size	-	1/2-in NPT	1/2-in NPT	-
	Rollout switch opens / closes (F)	-	195 / 115	195 / 115	-
	Temperature rise range (F)	-	40 - 70	35 - 70	-

- Not Applicable

**Table 10 – PHYSICAL DATA**

**(COOLING)**

**7.5 - 12.5 TONS**

	RGH090	RGH102	RGH110	RGH120	RGH150	
<b>Refrigeration System</b>						
# Circuits / # Comp. / Type	2 / 2 / Scroll	2 / 2 / Scroll	2 / 2 / Scroll	2 / 2 / Scroll	2 / 2 / Scroll	
R-410A Refrig charge A/B (lbs-oz)	9 - 10 / 9 - 10	9 - 14 / 9 - 14	12 - 10 / 13 - 0	12 - 11 / 12 - 5	16 - 7 / 15 - 5	
Hot Gas Re-Heat R-410A Refrig charge A/B (lbs-oz)	17-0 / 17-0	15-2 / 15-2	18-0 / 18-0	18-3 / 17-3	25-8 / 22-8	
Metering device	TXV	TXV	TXV	TXV	TXV	
High-press. Trip / Reset (psig)	630 / 505	630 / 505	630 / 505	630 / 505	630 / 505	
Low-press. Trip / Reset (psig)	54 / 117	54 / 117	27 / 44	54 / 117	54 / 117	
Compressor Capacity Staging (%)	50% / 100%	50% / 100%	50% / 100%	50% / 100%	50% / 100%	
<b>Evaporator Coil</b>						
Material (Tube/Fin)	Cu / Al	Cu / Al	Cu / Al	Cu / Al	Cu / Al	
Coil type	3/8-in RTPF	3/8-in RTPF	3/8-in RTPF	3/8-in RTPF	3/8-in RTPF	
Rows / FPI	4 / 15	4 / 15	4 / 15	4 / 15	4 / 15	
Total face area (ft <sup>2</sup> )	11.1	11.1	11.1	11.1	17.5	
Condensate drain conn. size	3/4-in	3/4-in	3/4-in	3/4-in	3/4-in	
<b>Hot Gas Re-Heat Coil</b>						
Material (Tube/Fin)	Cu / Al	Cu / Al	Cu / Al	Cu / Al	Cu / Al	
Coil type	3/8-in RTPF	3/8-in RTPF	3/8-in RTPF	3/8-in RTPF	3/8-in RTPF	
Rows / FPI	2 / 17	2 / 17	2 / 17	2 / 17	1 / 17	
Total face area (ft <sup>2</sup> )	6.3	8.4	8.6	8.6	13.8	
<b>Evaporator Fan and Motor</b>						
Standard Static 3 phase	Motor Qty / Drive type	1 / Belt	1 / Belt	1 / Belt	1 / Belt	1 / Belt
	Max BHP	1.7	1.7	2.4	2.4	2.9
	RPM range	518-733	518-733	591-838	591-838	440-609
	Motor Frame Size	56	56	56	56	56Y
	Fan Qty / Type	1 / Centrifugal	1 / Centrifugal	1 / Centrifugal	1 / Centrifugal	1 / Centrifugal
	Fan Diameter (in)	15 x 15	15 x 15	15 x 15	15 x 15	18 x 18
Medium Static 3 phase	Motor Qty / Drive type	1 / Belt	1 / Belt	1 / Belt	1 / Belt	1 / Belt
	Max BHP	2.4	2.4	3.7	3.7	3.7
	RPM range	690-936	690-936	838-1084	838-1084	609-778
	Motor Frame Size	56	56	56HZ	56HZ	56HZ
	Fan Qty / Type	1 / Centrifugal	1 / Centrifugal	1 / Centrifugal	1 / Centrifugal	1 / Centrifugal
	Fan Diameter (in)	15 x 15	15 x 15	15 x 15	15 x 15	18 x 18
High Static 3 phase	Motor Qty / Drive Type	1 / Belt	1 / Belt	1 / Belt	1 / Belt	1 / Belt
	Max BHP	3.7	3.7	4.9	4.9	6.1
	RPM range	838-1084	838-1084	1022-1240	1022-1240	776-955
	Motor Frame Size	56	56	145TY	145TY	S184T
	Fan Qty / Type	1 / Centrifugal	1 / Centrifugal	1 / Centrifugal	1 / Centrifugal	1 / Centrifugal
	Fan Diameter (in)	15 x 15	15 x 15	15 x 15	15 x 15	18 x 18
<b>Condenser Coil</b>						
Material (Tube/Fin)	Cu / Al	Cu / Al	Cu / Al	Cu / Al	Cu / Al	
Coil type	3/8-in RTPF	3/8-in RTPF	3/8-in RTPF	3/8-in RTPF	3/8-in RTPF	
Rows / FPI	2 / 17	2 / 17	3 / 17	3 / 17	2 / 17	
Total Face Area (ft <sup>2</sup> )	25.1	25.1	25.1	25.1	2 at 23.1	
<b>Condenser Fan / Motor</b>						
Qty / Motor drive type	2 / direct	2 / direct	1 / direct ECM	1 / direct	3 / direct	
Motor HP / RPM	1/4 / 1100	1/4 / 1100	1 / 1050	1 / 1175	1/4 / 1100	
Fan diameter (in)	22	22	30	30	22	
<b>Filters</b>						
RA Filter # / size (in)	4 / 20 x 20 x 2	4 / 20 x 20 x 2	4 / 20 x 20 x 2	4 / 20 x 20 x 2	6 / 18 x 24 x 2	
OA inlet screen # / size (in)	1 / 20 x 24 x 1	1 / 20 x 24 x 1	1 / 20 x 24 x 1	1 / 20 x 24 x 1	Vert 2 / 24 x 27 x 1 Horz 1 / 30 x 39 x 1	

- Not Applicable

**Table 11 – PHYSICAL DATA**

**(HEATING)**

**7.5 - 12.5 TONS**

		RGH090	RGH102	RGH110	RGH120	RGH150
Gas Connection						
	# of Gas Valves	1	1	1	1	1
	Nat. gas supply line press (in. w.g.)/(PSIG)	4 - 13 / 0.18 - 0.47	4 - 13 / 0.18 - 0.47	4 - 13 / 0.18 - 0.47	4 - 13 / 0.18 - 0.47	5 - 13 / 0.18 - 0.47
	Propane supply line press (in. w.g.)/(PSIG)	11 - 13 / 0.40 - 0.47	11 - 13 / 0.40 - 0.47	11 - 13 / 0.40 - 0.47	11 - 13 / 0.40 - 0.47	11 - 13 / 0.40 - 0.47
Heat Anticipator Setting (Amps)						
	1st stage	0.14	0.14	0.14	0.14	0.14
	2nd stage	0.14	0.14	0.14	0.14	0.14
Natural Gas, Propane Heat						
LOW	# of stages / # of burners (total)	2 / 3	2 / 3	2 / 4	2 / 4	2 / 5
	Connection size	1/2-in NPT	1/2-in NPT	3/4-in NPT	3/4-in NPT	3/4-in NPT
	Rollout switch opens / closes (F)	195 / 115	195 / 115	195 / 115	195 / 115	225 / 145
	Temperature rise range (F)	20 - 50	20 - 50	25 - 65	25 - 65	15 - 60
MED	# of stages / # of burners (total)	2 / 4	2 / 4	2 / 5	2 / 5	2 / 6
	Connection size	3/4-in NPT	3/4-in NPT	3/4-in NPT	3/4-in NPT	3/4-in NPT
	Rollout switch opens / closes (F)	195 / 115	195 / 115	195 / 115	195 / 115	225 / 145
	Temperature rise range (F)	35 - 65	30 - 65	30 - 65	30 - 65	20 - 55
HIGH	# of stages / # of burners (total)	2 / 5	2 / 5	2 / 5	2 / 5	2 / 8
	Connection size	3/4-in NPT	3/4-in NPT	3/4-in NPT	3/4-in NPT	3/4-in NPT
	Rollout switch opens / closes (F)	195 / 115	195 / 115	195 / 115	195 / 115	225 / 145
	Temperature rise range (F)	45 - 75	40 - 75	35 - 70	35 - 70	25 - 60

# CURBS & WEIGHTS DIMENSIONS - RGH036-060

- NOTES:
1. DIMENSIONS ARE IN INCHES. DIMENSIONS IN [ ] ARE IN MILLIMETERS.
  2. CENTER OF GRAVITY
  3. DIRECTION OF AIR FLOW

UNIT	J	K
RGH036	33-3/8 [847]	18-5/8 [472]
RGH048	41-3/8 [1051]	14-7/8 [377]
RGH060	41-3/8 [1051]	14-7/8 [377]

CONNECTION SIZES	
A	1 3/8" [35] DIA. FIELD POWER SUPPLY HOLE
B	2" [50.8] DIA. POWER SUPPLY KNOCKOUT
C	1 3/4" [44.45] DIA. GAUGE ACCESS PLUG
D	7/8" [22.23] DIA. FIELD CONTROL WIRING HOLE
E	3/4" x 1/4" NPT CONDENSATE DRAIN
F	1/2" x 1/4" NPT GAS CONNECTION
G	2 1/2" x [64] DIA. POWER SUPPLY KNOCK-OUT

THRU-THE-BASE CHART THESE HOLES REQUIRED FOR USE CRB1MWR001A01 - 003A01	
W	1/2" ACC. 7/8" [22.23]
X	3/4" [20.00] POWER 1 1/8" [28.41]
Z	1/2" [12.70] GAS 1 3/16" [30.01]

FOR "THRU-THE-BASEPAN" FACTORY OPTION, FITTINGS FOR ONLY X, Y, & Z ARE PROVIDED

\* SELECT EITHER 3/4" OR 1/2" FOR POWER, DEPENDING ON WIRE SIZE

\*\* (001) PROVIDES 3/4" FPT THRU CURB FLANGE & FITTING.

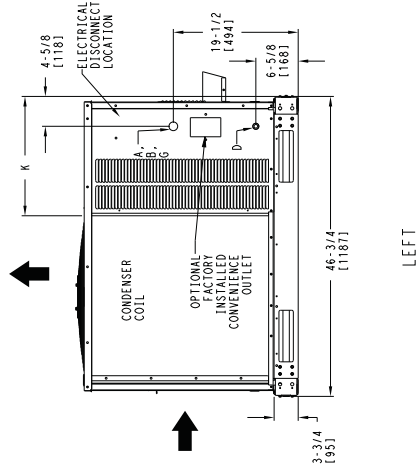
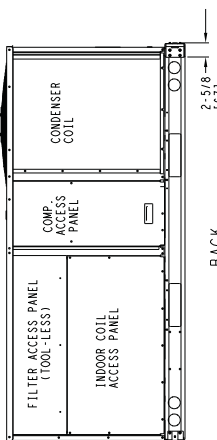
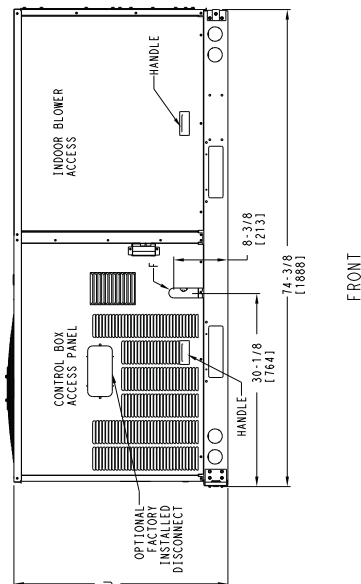
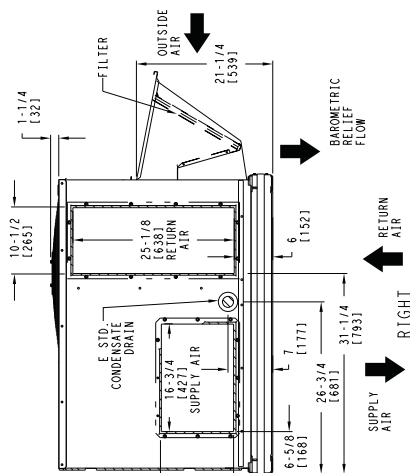
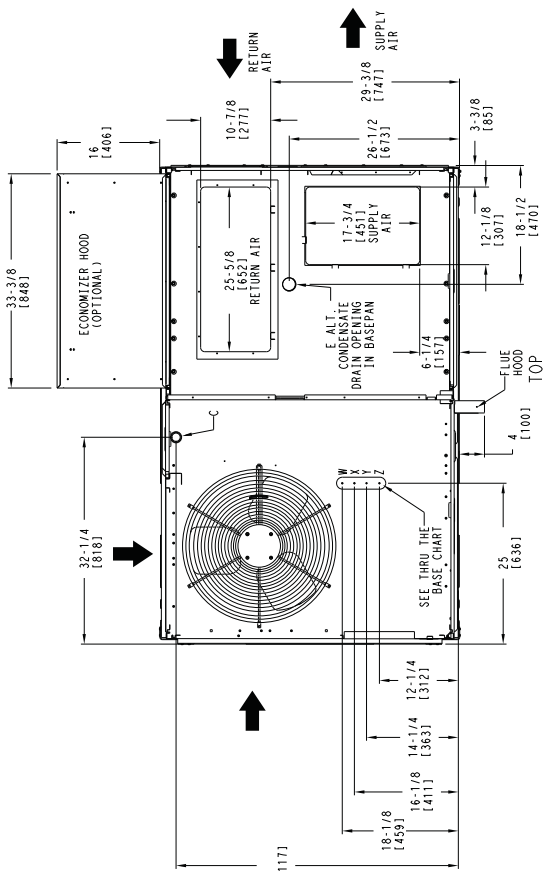

Fig. 1 - Dimensions RGH036-060

Specifications subject to change without notice.

# CURBS & WEIGHTS DIMENSIONS - RGH036-060 (cont)

UNIT	STD. UNIT WEIGHT		CORNER WEIGHT (A)		CORNER WEIGHT (B)		CORNER WEIGHT (C)		CORNER WEIGHT (D)		C. G.		HEIGHT
	LBS.	KG.	LBS.	KG.	LBS.	KG.	LBS.	KG.	LBS.	KG.	X	Y	
RGH036	505	229	124	56	117	53	128	58	136	62	36 1/8 [918]	24 3/8 [619]	19 [483]
RGH048	590	268	151	69	144	65	144	65	151	69	36 1/4 [921]	23 3/8 [594]	20 1/8 [511]
RGH060	600	271	156	71	145	66	144	65	155	70	35 7/8 [911]	23 1/4 [591]	19 1/2 [495]

\* - STANDARD UNIT WEIGHT IS WITH LOW GAS HEAT AND WITHOUT PACKAGING. FOR OTHER OPTINS AND ACCESSORIES REFER TO THE PRODUCT DATA CATALOG.

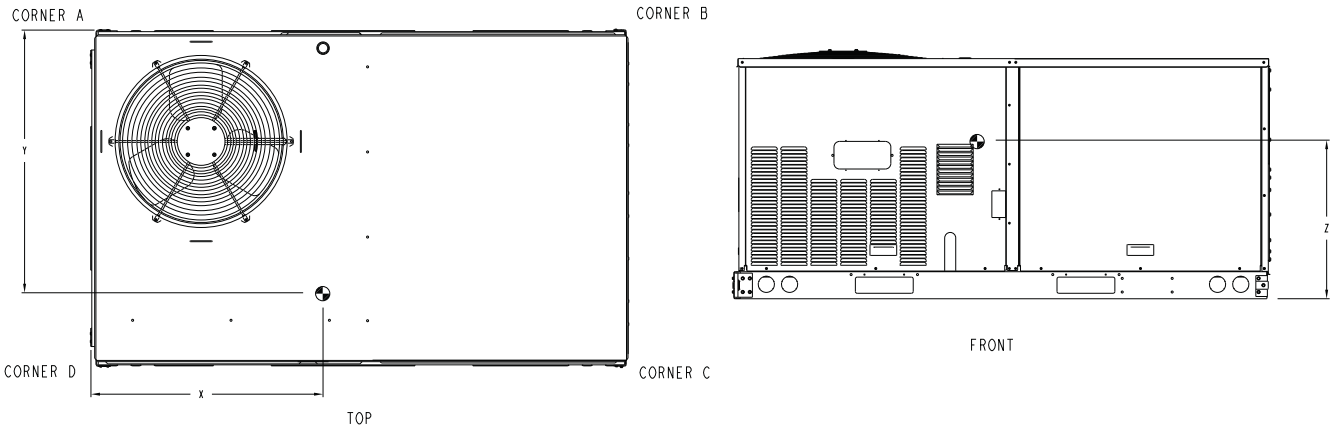

**Fig. 2 - Dimensions RGH036-060**

C10105B

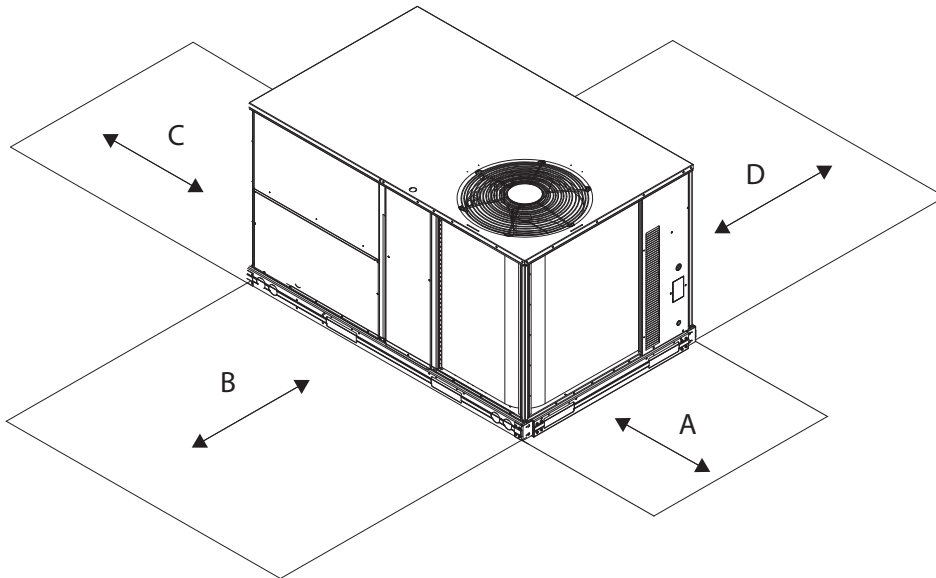

**Fig. 3 - Service Clearance**

C08337

LOC	DIMENSION	CONDITION
A	48-in (1219 mm)	Unit disconnect is mounted on panel
	18-in (457 mm)	No disconnect, convenience outlet option
	18-in (457 mm)	Recommended service clearance
	12-in (305 mm)	Minimum clearance
B	42-in (1067 mm)	Surface behind servicer is grounded (e.g., metal, masonry wall)
	36-in (914 mm)	Surface behind servicer is electrically non-conductive (e.g., wood, fiberglass)
	Special	Check for sources of flue products within 10-ft of unit fresh air intake hood
C	36-in (914 mm)	Side condensate drain is used
	18-in (457 mm)	Minimum clearance
D	48-in (1219 mm)	No flue discharge accessory installed, surface is combustible material
	42-in (1067 mm)	Surface behind servicer is grounded (e.g., metal, masonry wall, another unit)
	36-in (914 mm)	Surface behind servicer is electrically non-conductive (e.g., wood, fiberglass)
	Special	Check for adjacent units or building fresh air intakes within 10-ft of this unit's flue outlet

**NOTE:** Unit not designed to have overhead obstruction. Contact Application Engineering for guidance on any application planning overhead obstruction or for vertical clearances.

# CURBS & WEIGHTS DIMENSIONS - RGH036-060 (cont)

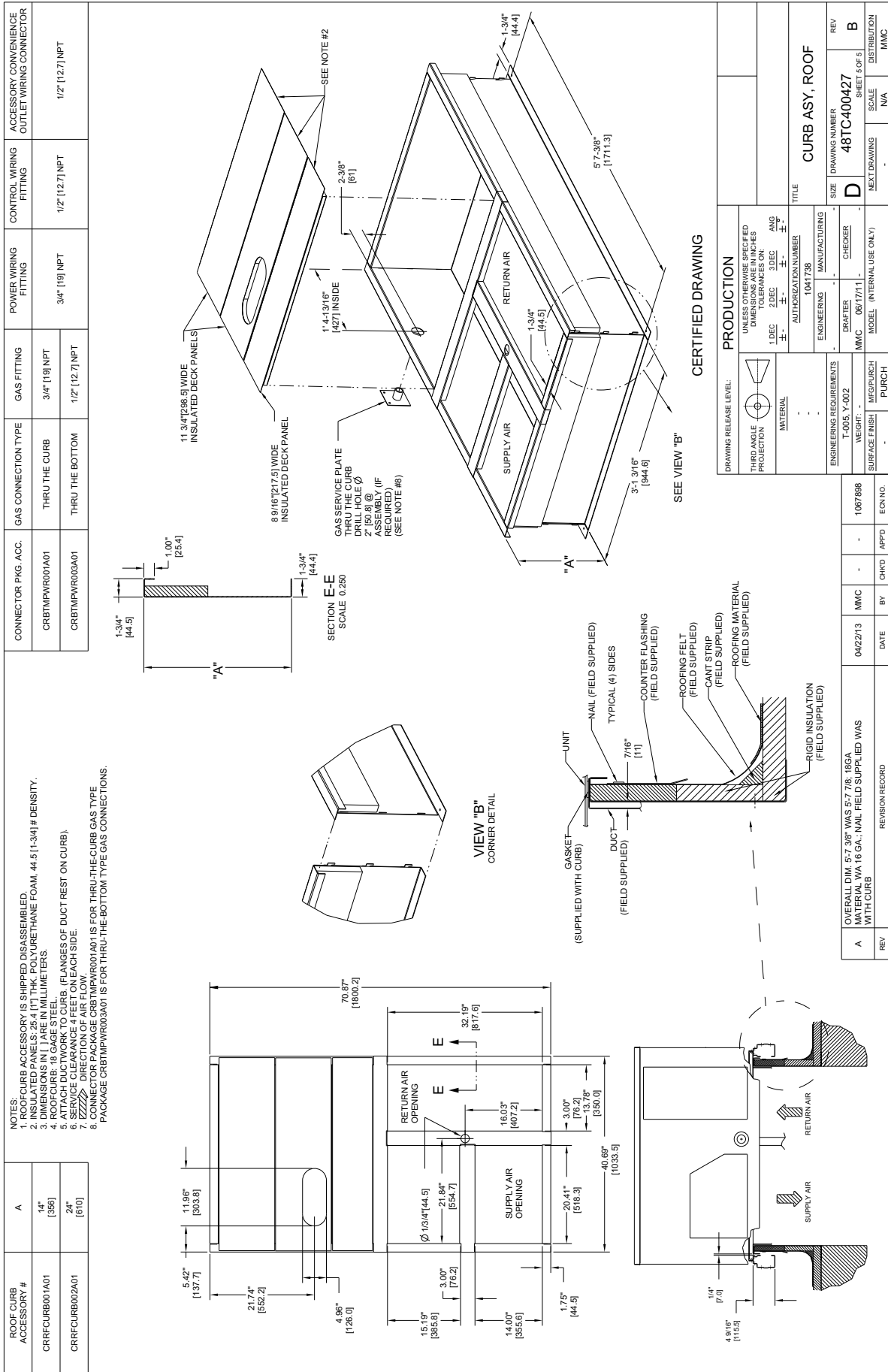

**Fig. 4 - Roof Curb Details**

Specifications subject to change without notice.

# CURBS & WEIGHTS DIMENSIONS - RGH072-102

CONNECTION SIZES	
A	1 3/8" [35] DIA FIELD POWER SUPPLY KNOCKOUT
B	2 1/2" [64] DIA POWER SUPPLY KNOCKOUT
C	1 3/4" [51] DIA GAUGE ACCESS PLUG
D	7/8" [22] DIA FIELD CONTROL WIRING HOLE
E	3/4" - 14 NPT CONDENSATE DRAIN
F	1/2" - 14 NPT GAS CONNECTION
G	3/4" - 14 NPT GAS CONNECTION
	2" [51] DIA POWER SUPPLY KNOCK-OUT

THRU-THE-BASE CHART (FIELD INST)	
THESE HOLES REQUIRED FOR USE WITH ACCY KITS:	
CBTIPMR001A01	: 072-073 - GAS THRU CURB
CBTIPMR002A01	: 090-102 - GAS THRU CURB
CBTIPMR003A01	: 072-073 - GAS THRU BASEPAN
CBTIPMR004A01	: 090-102 - GAS THRU BASEPAN
W	THREADED CONDUIT SIZE
W	1/2" ACC. 7/8" [22.2]
X	1/2" 24V 7/8" [22.2]
Y	3/4" (001, 003) POWER 1 1/8" [28.6]
	1 1/4" (002, 004) 1 3/4" [44.4]
Z	(003) 1/2" FPT GAS 1 1/8" [28.6]
	(004) 3/4" FPT GAS 1 3/4" [44.4]
*	(001 & 002) PROVIDES 3/4" FPT THRU CURB FLANGE & FITTING. HOLE SIZE: 2" [50.8]

THRU-THE-BASE CHART (F.T.O.P)	
FOR THRU-THE-BASEPAN, FACTORY OPTION FITTINGS FOR CURB W/ WIRE PROVIDED. **	
FOR BELOW FIELD WORKS, A FIELD SUPPLIED 1/2" ADAPTER IS REQUIRED BETWEEN BASE PAN FITTING AND GAS VALVE: RGH072-073-D-E-L-M-S-R	
RGH096-D-L-S	
RGH102-D-L-S	

UNIT	J	K	H
RGH072, 073	41 [1047]	33-3/4 [857]	15-3/8 [403]
RGH090	10-3/8 [263]	39-3/8 [100]	14-3/8 [365]
RGH102	19-3/8 [500]	36-3/8 [925]	15-7/8 [403]

- NOTES:
1. DIMENSIONS ARE IN INCHES. DIMENSIONS IN " " ARE IN MILLIMETERS.
  2. CENTER OF GRAVITY
  3. DIRECTION OF AIR FLOW

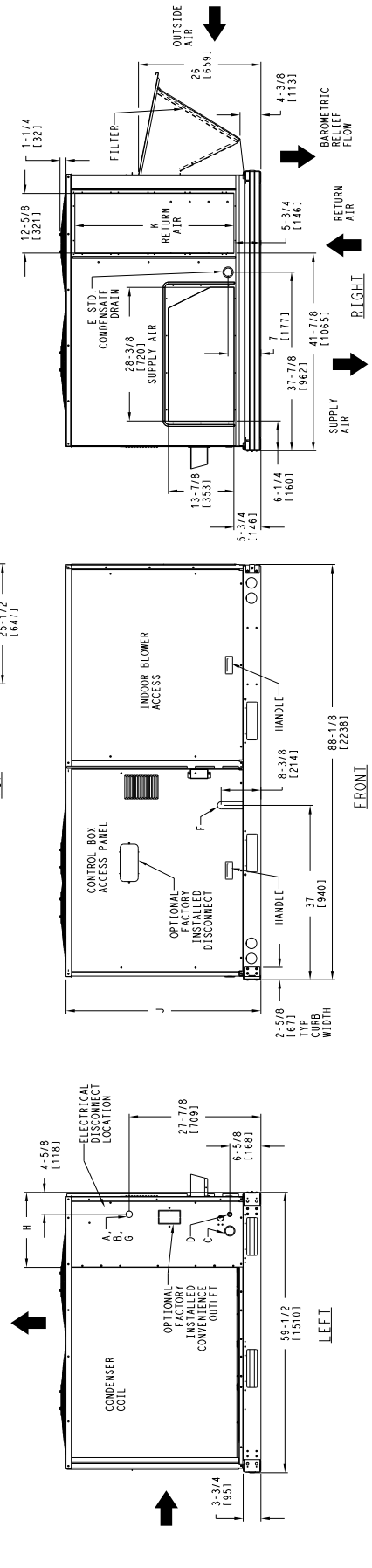
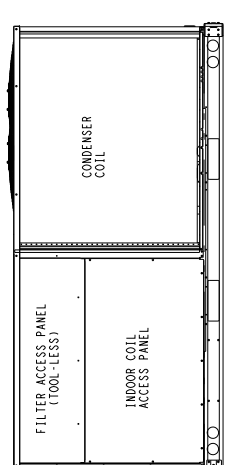
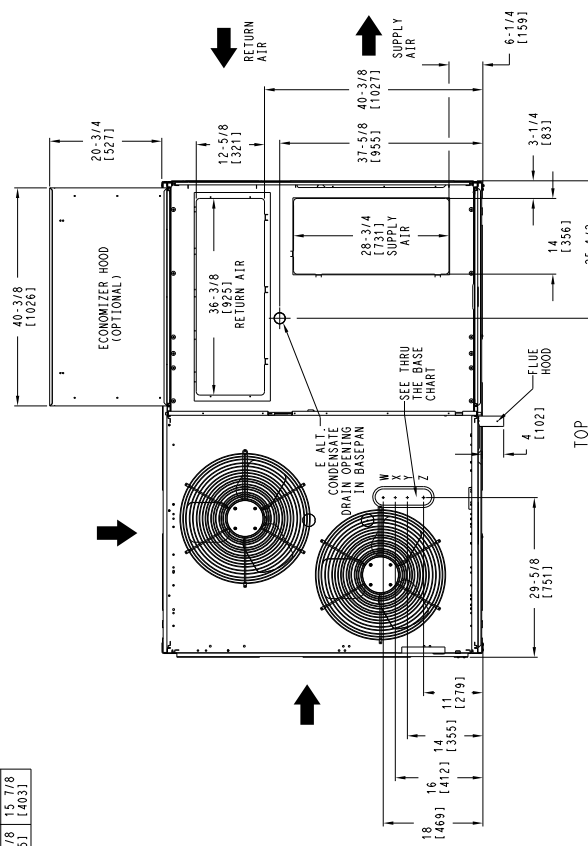
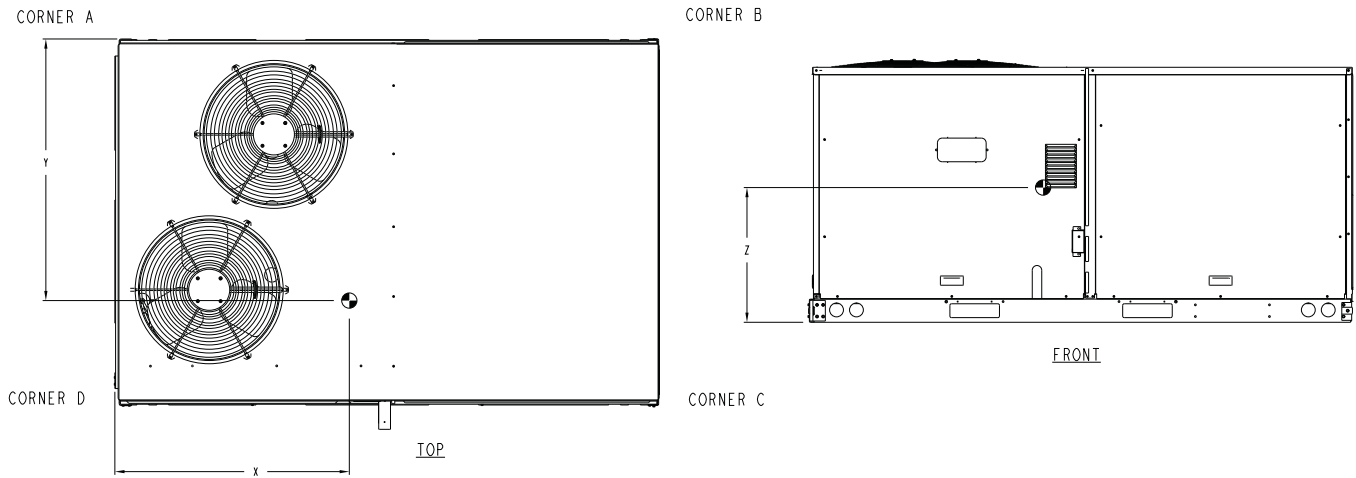

Fig. 5 - Dimensions RGH072 - 102

# CURBS & WEIGHTS DIMENSIONS - RGH072-102 (cont)

UNIT	STD. UNIT WEIGHT *		CORNER WEIGHT (A)		CORNER WEIGHT (B)		CORNER WEIGHT (C)		CORNER WEIGHT (D)		C.G.		
	LBS.	KG.	LBS.	KG.	LBS.	KG.	LBS.	KG.	LBS.	KG.	X	Y	Z
RGH072_073	765	347	165.3	75	152.7	69.3	214.7	97.4	232.3	105.4	42 3/8 [1076]	34 3/4 [882.6]	19 7/8 [505]
RGH090	925	419.5	204.1	92.6	190.9	86.6	256.1	116.2	273.9	124.2	42 5/8 [1082]	34 1/8 [867]	22 7/8 [581]
RGH102	925	419.5	204.1	92.6	190.9	86.6	256.1	116.2	273.9	124.2	42 5/8 [1082]	34 1/8 [867]	22 7/8 [581]



**Fig. 6 - Dimensions RGH072 - 102**

C11323B

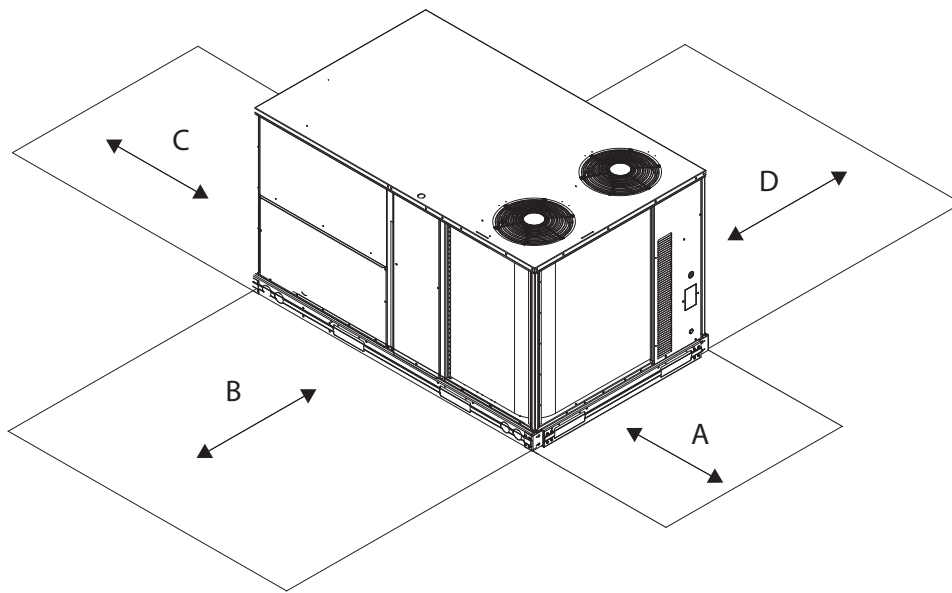

**Fig. 7 - Service Clearance**

C10577

LOC	DIMENSION	CONDITION
A	48-in (1219 mm)	Unit disconnect is mounted on panel
	18-in (457 mm)	No disconnect, convenience outlet option
	18-in (457 mm)	Recommended service clearance
	12-in (305 mm)	Minimum clearance
B	42-in (1067 mm)	Surface behind servicer is grounded (e.g., metal, masonry wall)
	36-in (914 mm)	Surface behind servicer is electrically non-conductive (e.g., wood, fiberglass)
	Special	Check for sources of flue products within 10-ft of unit fresh air intake hood
C	36-in (914 mm)	Side condensate drain is used
	18-in (457 mm)	Minimum clearance
D	48-in (1219 mm)	No flue discharge accessory installed, surface is combustible material
	42-in (1067 mm)	Surface behind servicer is grounded (e.g., metal, masonry wall, another unit)
	36-in (914 mm)	Surface behind servicer is electrically non-conductive (e.g., wood, fiberglass)
	Special	Check for adjacent units or building fresh air intakes within 10-ft of this unit's flue outlet

**NOTE:** Unit not designed to have overhead obstruction. Contact Application Engineering for guidance on any application planning overhead obstruction or for vertical clearances.

# CURBS & WEIGHTS DIMENSIONS - RGH110-120

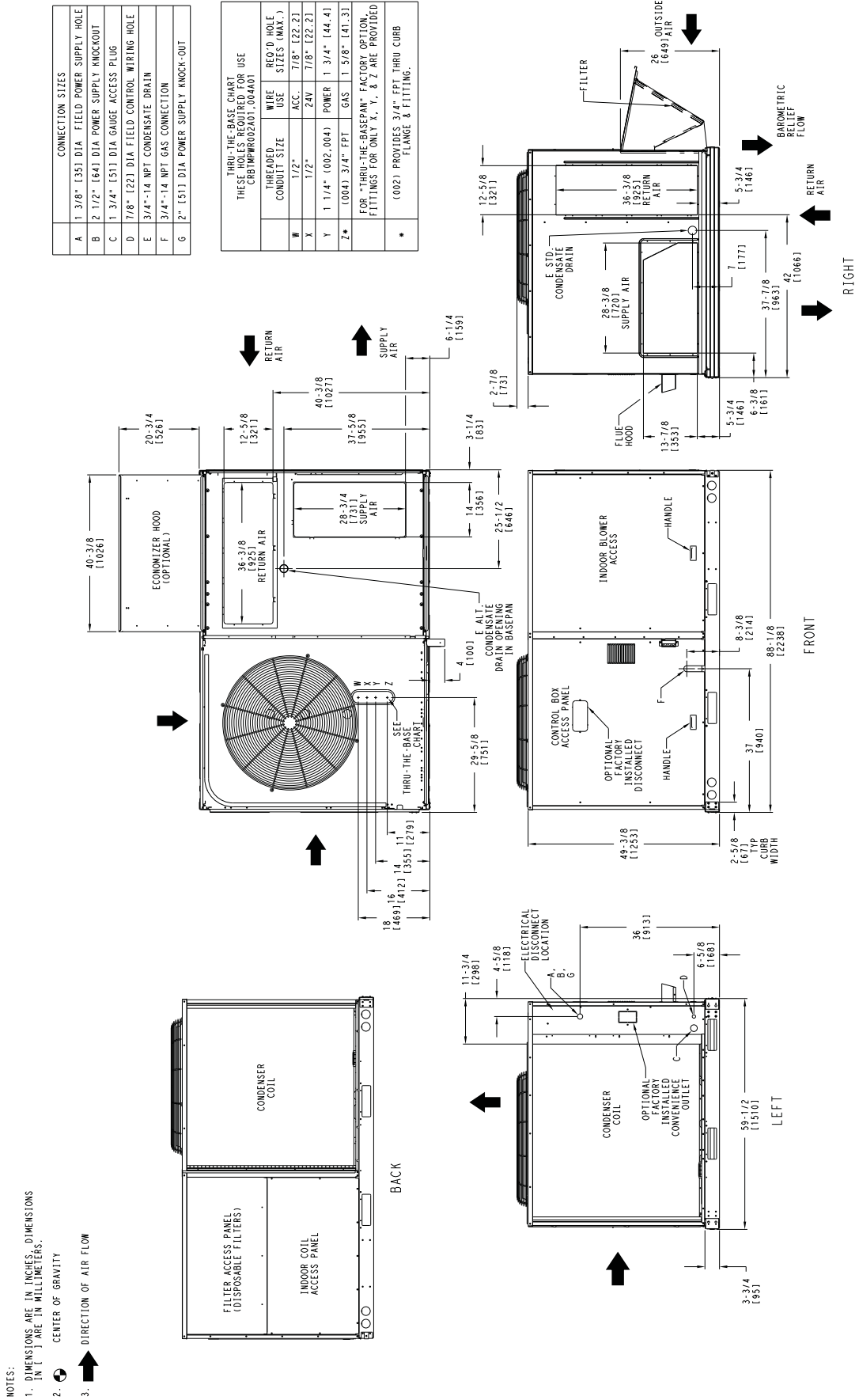

**Fig. 8 - Dimensions RGH110-120**

# CURBS & WEIGHTS DIMENSIONS - RGH110-120 (cont)

UNIT	STD. UNIT WEIGHT *		CORNER WEIGHT (A)		CORNER WEIGHT (B)		CORNER WEIGHT (C)		CORNER WEIGHT (D)		C.G.		
	LBS.	KG.	LBS.	KG.	LBS.	KG.	LBS.	KG.	LBS.	KG.	X	Y	Z
RGH120	1090	495	311	142	162	74	211	96	405	184	30 1/8 [766]	33 5/8 [855]	20 3/4 [528]
RGH110	1090	495	311	142	162	74	211	96	405	184	30 1/8 [766]	33 5/8 [855]	20 3/4 [528]

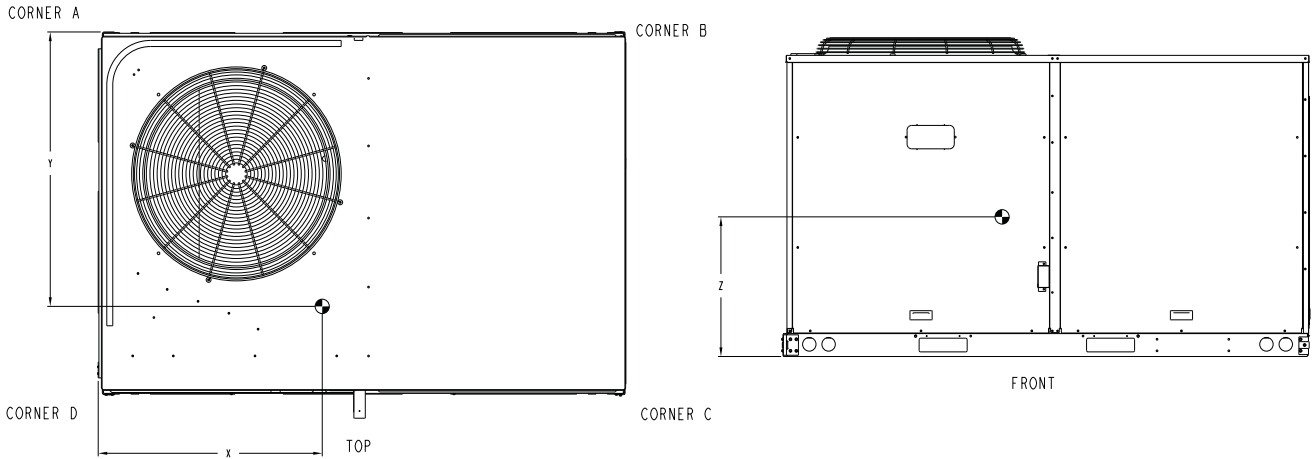

**Fig. 9 - Dimensions RGH120**

C13294B

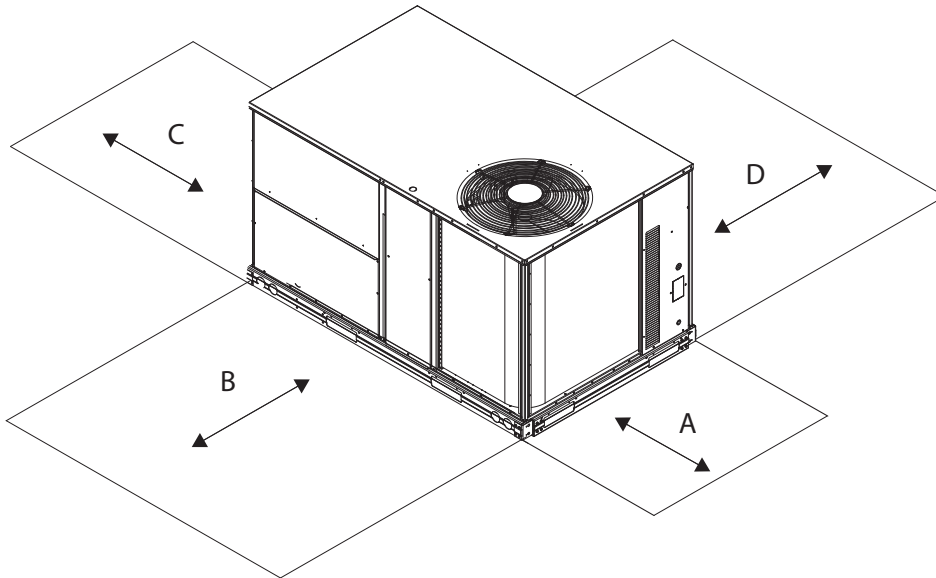

**Fig. 10 - Service Clearance**

C08337

LOC	DIMENSION	CONDITION
A	48-in (1219 mm)	Unit disconnect is mounted on panel
	18-in (457 mm)	No disconnect, convenience outlet option
	18-in (457 mm)	Recommended service clearance
	12-in (305 mm)	Minimum clearance
B	42-in (1067 mm)	Surface behind servicer is grounded (e.g., metal, masonry wall)
	36-in (914 mm)	Surface behind servicer is electrically non-conductive (e.g., wood, fiberglass)
	Special	Check for sources of flue products within 10-ft of unit fresh air intake hood
C	36-in (914 mm)	Side condensate drain is used
	18-in (457 mm)	Minimum clearance
D	48-in (1219 mm)	No flue discharge accessory installed, surface is combustible material
	42-in (1067 mm)	Surface behind servicer is grounded (e.g., metal, masonry wall, another unit)
	36-in (914 mm)	Surface behind servicer is electrically non-conductive (e.g., wood, fiberglass)
	Special	Check for adjacent units or building fresh air intakes within 10-ft of this unit's flue outlet

**NOTE:** Unit not designed to have overhead obstruction. Contact Application Engineering for guidance on any application planning overhead obstruction or for vertical clearances.

# CURBS & WEIGHTS DIMENSIONS - RGH072-120 (cont)

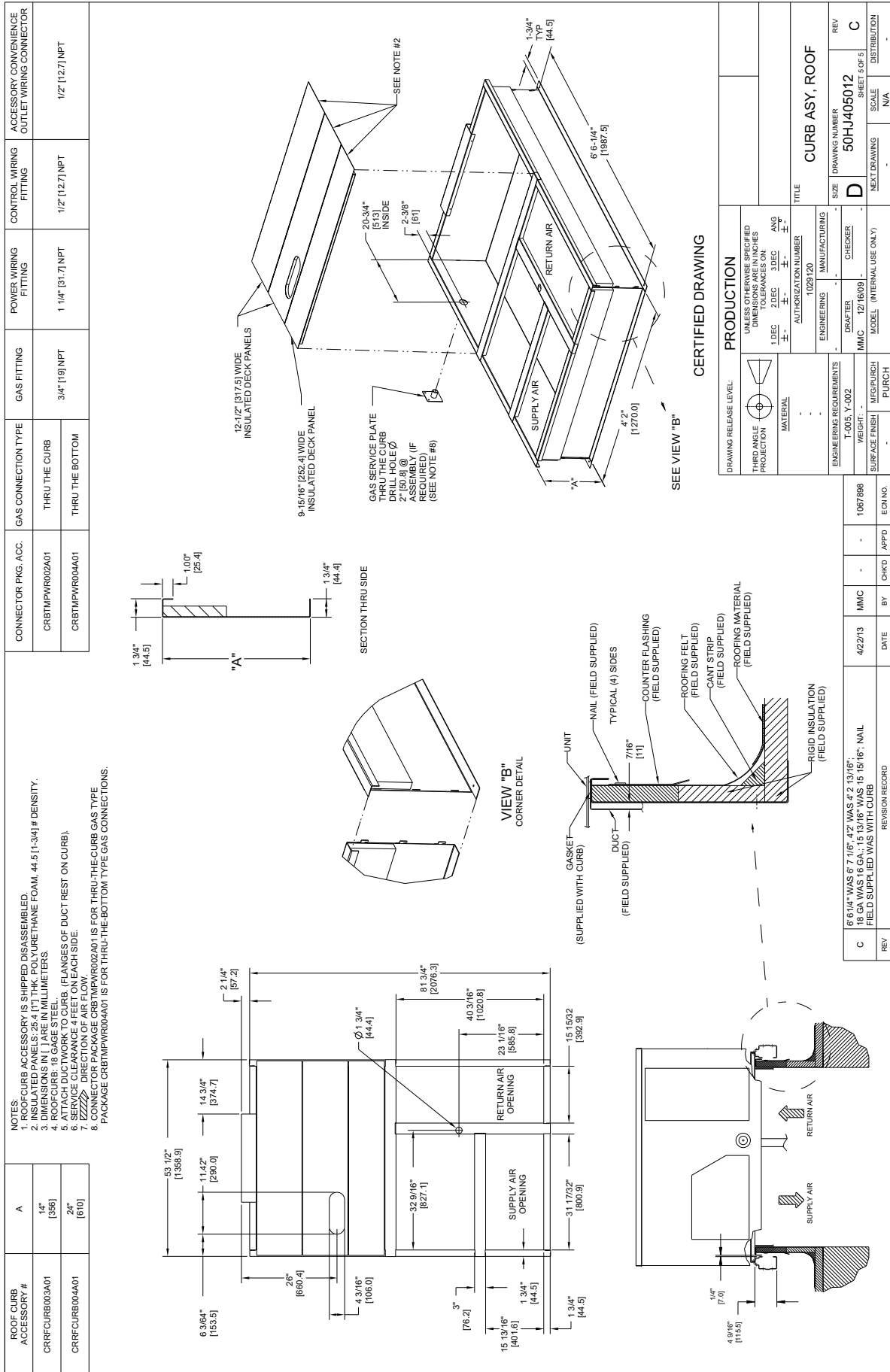

**Fig. 11 - Roof Curb Details**

Specifications subject to change without notice.

**509 71 3808 00**

C13311B

# CURBS & WEIGHTS DIMENSIONS - RGH150

CONNECTION SIZES	
B	2 1/2" [64] DIA. POWER SUPPLY HOLE
D	7/8" [22] DIA. FIELD CONTROL WIRING HOLE
E	3/4" - 14 NPT CONDENSATE DRAIN
F	7/8" [22] DIA. FIELD CONVENIENCE OUTLET HOLE
G	3/4" - 14 NPT GAS CONNECTION

THRU-THE-BASE CHART		THESE HOLES REQUIRED FOR USE	
ACCESSORY NO.	THREADED CONDUIT SIZE	WIRE SIZE (MAX.)	REQ'D HOLE SIZES (MAX.)
005	1/2"	ACC.	7/8" [22.2]
	1/2"	24V	7/8" [22.2]
	1/2"	POWER	1 1/2" [38.1]
006	3/4" PIPE	GAS	1 3/4" [44.5]
	1/2"	ACC.	7/8" [22.2]
	1/2"	POWER	2" [50.8]
007	3/4" PIPE	GAS	1 3/4" [44.5]
	1/2"	ACC.	7/8" [22.2]
	1/2"	POWER	2 1/2" [63.5]

FOR "THRU-THE-BASEPAN-FACILITY OPTION," FITTING IS PROVIDED AS SPECIFIED ON "006".

- NOTES:
1. DIMENSIONS ARE IN INCHES. DIMENSIONS IN ( ) ARE IN MILLIMETERS.
  2. CENTER OF GRAVITY
  3. DIRECTION OF AIR FLOW

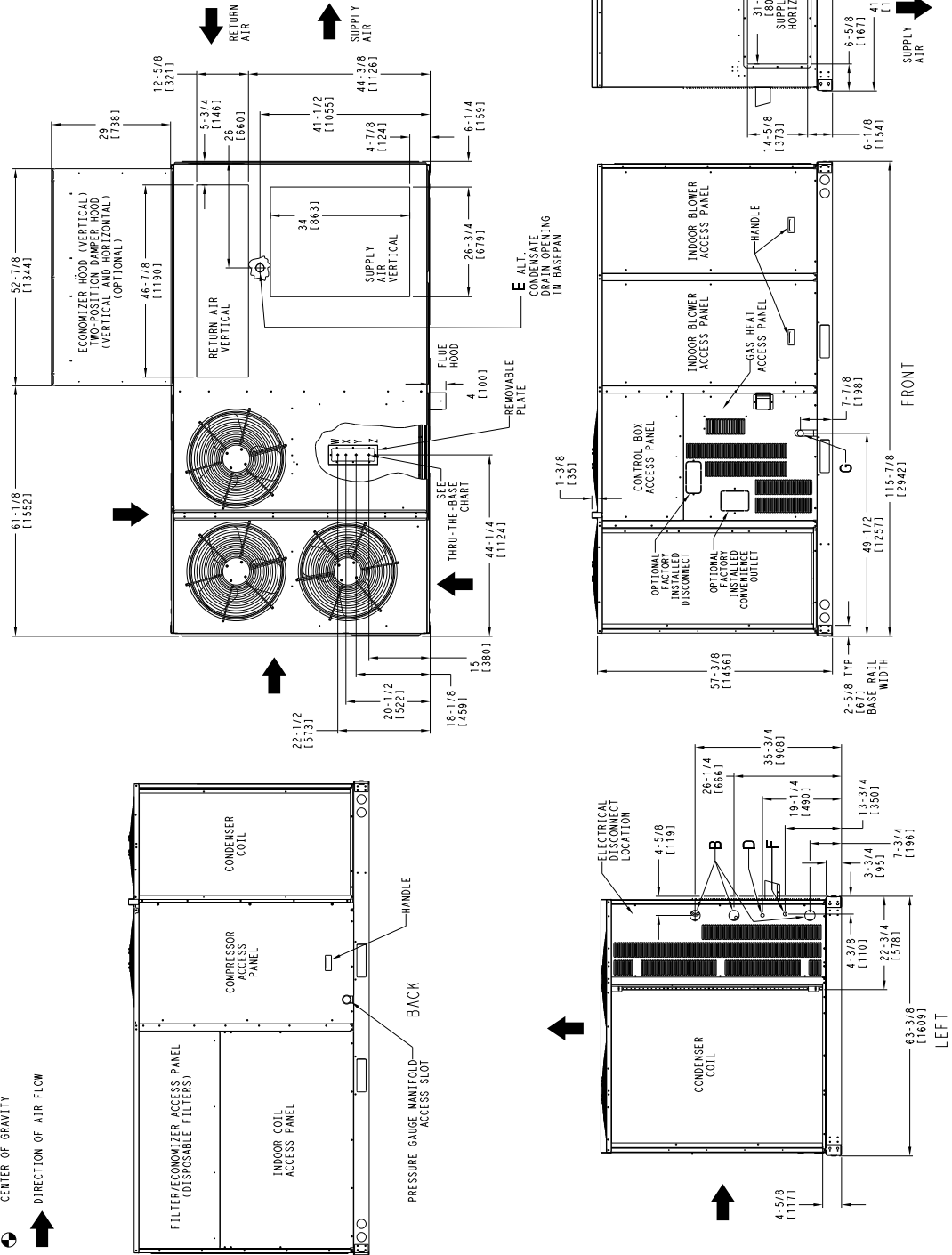

**Fig. 12 - Dimensions RGH150**

Specifications subject to change without notice.

# CURBS & WEIGHTS DIMENSIONS - RGH150 (cont)

UNIT	STD. UNIT WEIGHT		CORNER WEIGHT (A)		CORNER WEIGHT (B)		CORNER WEIGHT (C)		CORNER WEIGHT (D)		C.G.								
	LBS.	KG.	LBS.	KG.	LBS.	KG.	LBS.	KG.	LBS.	KG.	X	Y	Z						
RGH150	1430	649	342	155	377	171	372	169	338	153	60	3/4	11543	31	1/2	800	20	5/8	524

STANDARD UNIT WEIGHT IS WITHOUT MAX. GAS HEAT & WITHOUT PACKAGING. FOR OPTIONS & ACCESSORIES, REFER TO THE PRODUCT SPECIFICATIONS CATALOG.

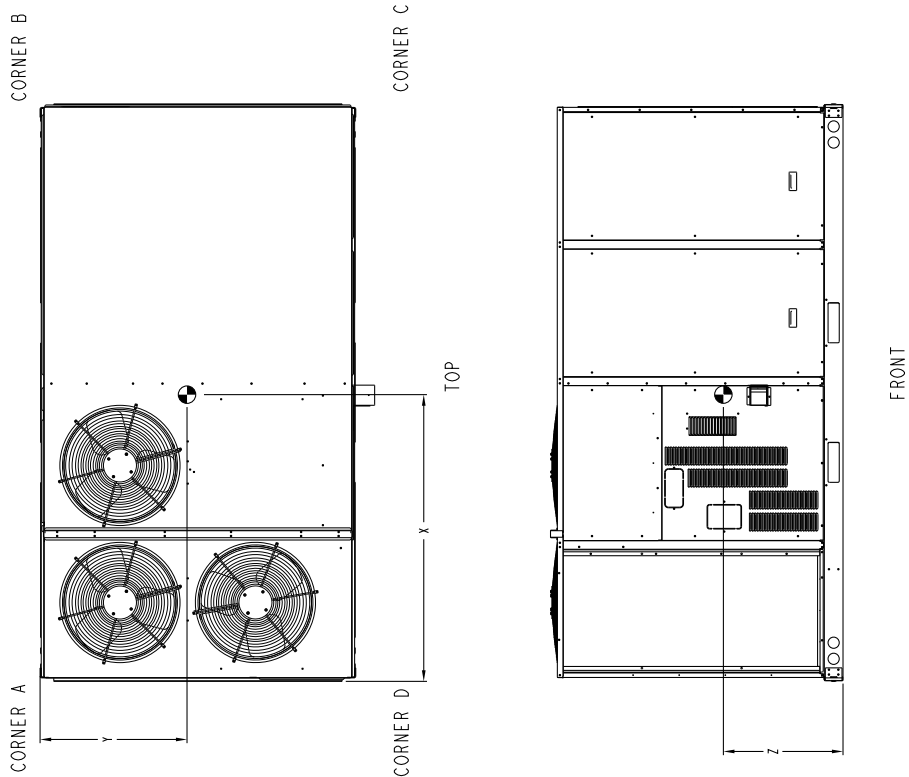
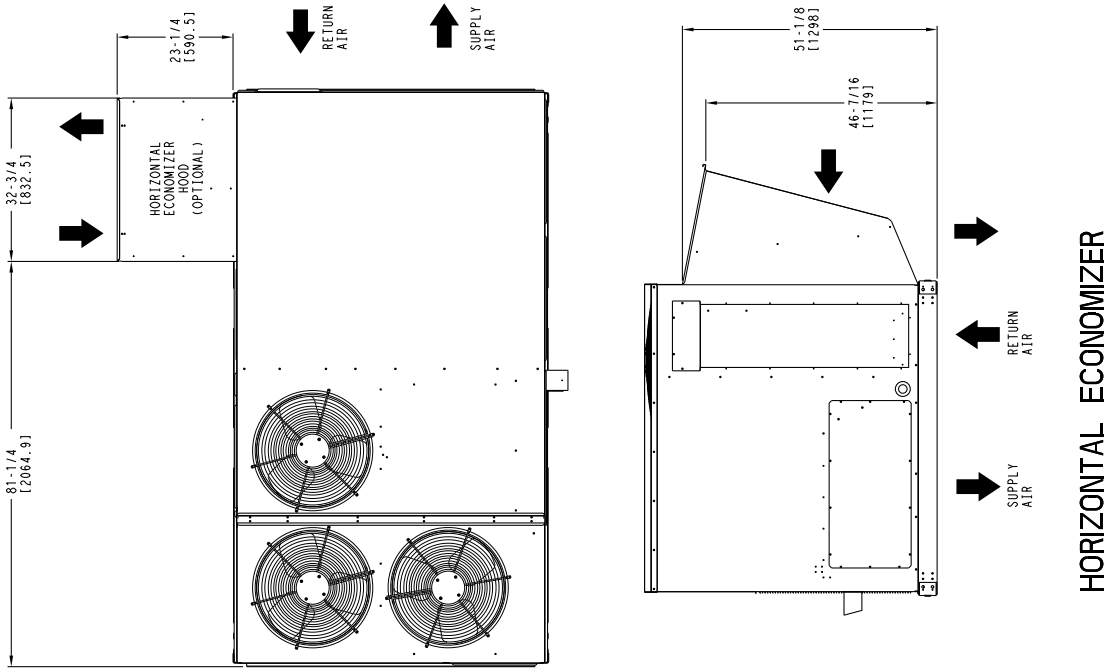
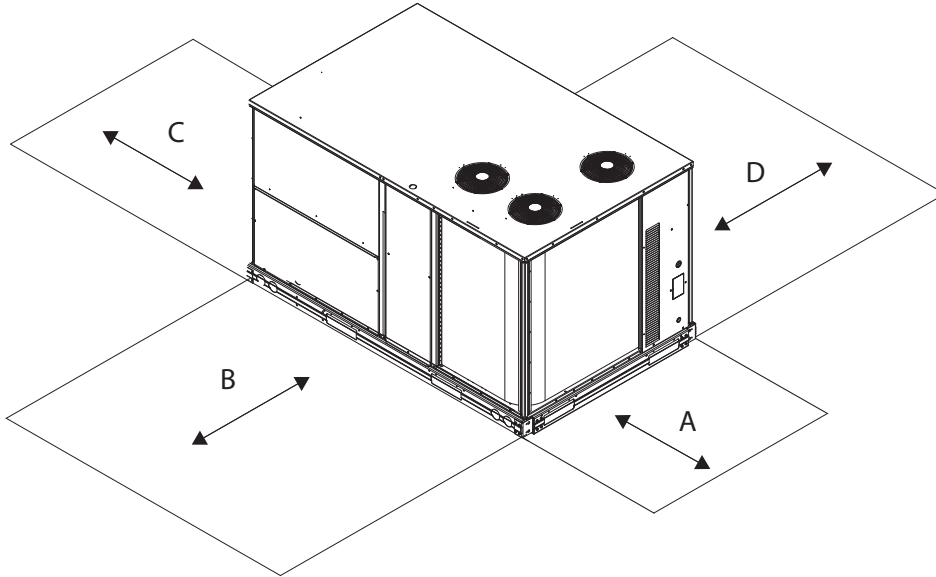

Fig. 13 - Dimensions RGH150

C11327B

## CURBS & WEIGHTS DIMENSIONS - RGH150 (cont)



**Fig. 14 - Service Clearance**

C10578B

LOC	DIMENSION	CONDITION
A	48-in (1219 mm)	Unit disconnect is mounted on panel
	18-in (457 mm)	No disconnect, convenience outlet option
	18-in (457 mm)	Recommended service clearance
	12-in (305 mm)	Minimum clearance
B	42-in (1067 mm)	Surface behind servicer is grounded (e.g., metal, masonry wall)
	36-in (914 mm)	Surface behind servicer is electrically non-conductive (e.g., wood, fiberglass)
	Special	Check for sources of flue products within 10-ft of unit fresh air intake hood
C	36-in (914 mm)	Side condensate drain is used
	18-in (457 mm)	Minimum clearance
D	48-in (1219 mm)	No flue discharge accessory installed or available, surface is combustible material
	42-in (1067 mm)	Surface behind servicer is grounded (e.g., metal, masonry wall, another unit)
	36-in (914 mm)	Surface behind servicer is electrically non-conductive (e.g., wood, fiberglass)
	Special	Check for adjacent units or building fresh air intakes within 10-ft of this unit's flue outlet

**NOTE:** Unit not designed to have overhead obstruction. Contact Application Engineering for guidance on any application planning overhead obstruction or for vertical clearances.

# CURBS & WEIGHTS DIMENSIONS - RGH150 (cont)

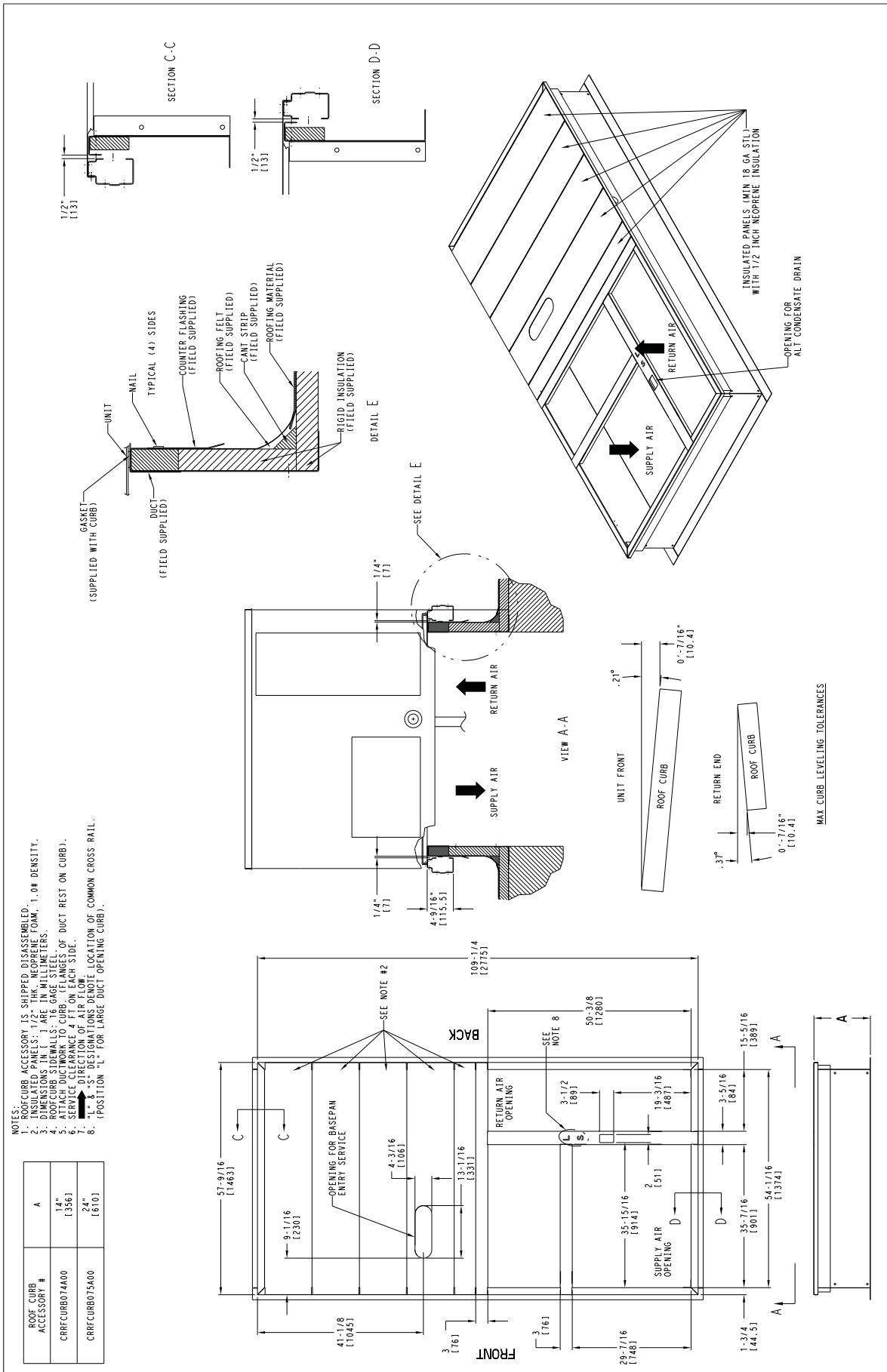

Fig. 15 - Roof Curb Details

## OPTIONS & ACCESSORY WEIGHTS

Option / Accessory	OPTION / ACCESSORY WEIGHTS																	
	036		048		060		072/073		090		102		110		120		150	
	lb	kg	lb	kg	lb	kg	lb	kg	lb	kg	lb	kg	lb	kg	lb	kg	lb	kg
Hot Gas Re-Heat <sup>1</sup>	50	23	55	25	55	25	80	36	80	36	80	36	85	39	85	39	90	41
Power Exhaust - vertical	50	23	50	23	50	23	75	34	75	34	75	34	75	34	75	34	85	39
Power Exhaust - horizontal	30	14	30	14	30	14	30	14	30	14	30	14	30	14	30	14	75	34
EconoMiSer <sup>®</sup> (X, IV or 2)	50	23	50	23	50	23	75	34	75	34	75	34	75	34	75	34	132	60
Two Position damper	39	18	39	18	39	18	58	26	58	26	58	26	58	26	58	26	65	29
Manual Dampers	12	5	12	5	12	5	18	8	18	8	18	8	18	8	18	8	25	11
Medium Gas Heat	12	5	9	4	9	4	15	7	15	7	15	7	18	8	18	8	18	8
High Gas Heat	-	-	17	8	17	8	29	13	29	13	29	13	35	16	35	16	42	19
Hail Guard (louvered)	16	7	16	7	16	7	34	15	34	15	34	15	34	15	34	15	45	20
Cu/Cu Condenser Coil	35	16	35	16	35	16	95	43	95	43	95	43	170	77	170	77	190	86
Cu/Cu Cond. & Evap. Coils	60	27	60	27	90	41	140	64	140	64	195	88	270	122	270	122	280	127
Roof Curb (14-in. curb)	115	52	115	52	115	52	143	65	143	65	143	65	143	65	143	65	180	82
Roof Curb (24-in. curb)	197	89	197	89	197	89	245	111	245	111	245	111	245	111	245	111	255	116
CO <sub>2</sub> sensor	5	2	5	2	5	2	5	2	5	2	5	2	5	2	5	2	5	2
Flue Discharge Deflector	7	3	7	3	7	3	7	3	7	3	7	3	7	3	7	3	-	-
Optional Indoor Motor/Drive	10	5	10	5	10	5	15	7	15	7	15	7	15	7	15	7	45	20
Motormaster <sup>®</sup> Controller	35	16	35	16	35	16	35	16	35	16	35	16	35	16	35	16	40	18
Low Ambient Controller	5	2	5	2	5	2	5	2	5	2	5	2	8	3	10	5	30	14
Return Smoke Detector	5	2	5	2	5	2	5	2	5	2	5	2	5	2	5	2	5	2
Supply Smoke Detector	5	2	5	2	5	2	5	2	5	2	5	2	5	2	5	2	5	2
Fan/Filter Status Switch	2	1	2	1	2	1	2	1	2	1	2	1	2	1	2	1	2	1
Non-Fused Disconnect	15	7	15	7	15	7	15	7	15	7	15	7	15	7	15	7	15	7
Powered Convenience Outlet	35	16	35	16	35	16	35	16	35	16	35	16	35	16	35	16	35	16
Non-Powered C.O.	5	2	5	2	5	2	5	2	5	2	5	2	5	2	5	2	5	2
Enthalpy Sensor	2	1	2	1	2	1	2	1	2	1	2	1	2	1	2	1	2	1
Differential Enthalpy Sensor	3	1	3	1	3	1	3	1	3	1	3	1	3	1	3	1	3	1
2-Speed Indoor Fan Motor System with VFD	-	-	-	-	-	-	20	9	20	9	20	9	20	9	20	9	20	9

**NOTE:** Where multiple variations are available, the heaviest combination is listed.

- Not Available

<sup>1</sup> For Hot Gas Re-Heat add Motormaster Controller.

## APPLICATION DATA

### Min operating ambient temp (cooling):

In mechanical cooling mode, your ICP rooftop unit can safely operate down to an outdoor ambient temperature of 35°F (-2°C) and 25°F (-4°C), with an accessory winter start kit. It is possible to provide cooling at lower outdoor ambient temperatures by using less outside air, economizers, and/or accessory low ambient kits.

### Max operating ambient temp (cooling):

The maximum operating ambient temperature for cooling mode is 125°F (52°C). While cooling operation above 125°F (52°C) may be possible, it could cause either a reduction in performance, reliability, or a protective action by the unit's internal safety devices.

### Min mixed air temp (heating):

Using the factory settings, the minimum temperatures for the mixed air (the combined temperature of the warm return air and the cold outdoor air) entering the dimpled, gas heat exchangers are:

<u>Aluminized</u>	<u>Stainless Steel</u>
50°F (10°C) continuous	40°F (4°C) continuous
45°F (7°C) intermittent	35°F (2°C) intermittent

Operating at lower mixed-air temperatures may be possible, if a field-supplied, outdoor air thermostat initiates both heat stages when the temperature is less than the minimum temperatures listed above. Please contact your local ICP representative for assistance.

### Min and max airflow (heating and cooling):

To maintain safe and reliable operation of your rooftop, operate within the heating airflow limits during heating mode and cooling airflow limits during cooling mode. Operating above the max may cause blow-off, undesired airflow noise, or airflow related problems with the rooftop unit. Operating below the min may cause problems with coil freeze-up and unsafe heating operation. For proper minimum-maximum CFM values see Table 7.

### Heating-to-cooling changeover:

Your unit will automatically change from heating to cooling mode when using a thermostat with an auto-change-over feature.

### Airflow:

All units are draw-through in cooling mode and blow-through in heating mode.

### Outdoor air application strategies:

Economizers reduce operating expenses and compressor run time by providing a free source of cooling and a means of ventilation to match application changing needs. In fact, they should be considered for most applications. Also, consider the various economizer control methods and their benefits, as well as sensors required to accomplish your application goals. Please contact your local ICP representative for assistance.

### Motor limits, break horsepower (BHP):

Due to internal design of ICP units, the air path, and specially designed motors, the full horsepower (maximum continuous BHP) band, as listed in Table 8 and 10, can be used with the utmost confidence. There is no need for extra safety factors, as ICP motors are designed and rigorously tested to use the entire, listed BHP range without either nuisance tripping or premature motor failure.

### Propane heating:

Propane has different physical qualities than natural gas. As a result, Propane requires different fuel to air mixture. To optimize the fuel/air mixture for Propane, ICP sells different burner orifices in an easy to install accessory kit. To select the correct burner orifices or determine the heat capacity for an Propane application, use either the selection software, or the unit's service manual.

### High altitude heating:

High altitudes have less oxygen, which affects the fuel/air mixture in heat exchangers. In order to maintain a proper fuel/air mixture, heat exchangers operating in altitudes above 2000 ft (610m) require different orifices. To select the correct burner orifices or determine the heat capacity for a high altitude application, use either the selection software, or the unit's service manual.

High altitudes have less oxygen, which means heat exchangers need less fuel. The new gas orifices in this field-installed kit make the necessary adjustment for high altitude applications. They significantly improve fuel to air mixture and maintain healthy combustion on altitudes above 2000 ft (610m).

**NOTE:** Typical natural gas heating value ranges from 975 to 1050 Btu/ft<sup>3</sup> at sea level nationally. The heating value goes down approximately 1.7% per every thousand feet elevation. Standard factory orifices can typically be used up to 2000 ft (610m) elevation without any operational issues.

## APPLICATION DATA (cont)

### Sizing a rooftop

Bigger isn't necessarily better. While an air conditioner needs to have enough capacity to meet the design loads, it doesn't need excess capacity. In fact, excess capacity typically results in very poor part load performance and humidity control.

Using higher design temperatures than ASHRAE recommends for your location, adding "safety factors" to the calculated load, are all signs of oversizing air conditioners. Oversizing the air conditioner leads to poor humidity control, reduced efficiency, higher utility bills, larger indoor temperature swings, excessive noise, and increased wear and tear on the air conditioner.

Rather than oversizing an air conditioner, engineers should "right-size" or even slightly undersize air conditioners. Correctly sizing an air conditioner controls humidity better; promotes efficiency; reduces utility bills; extends equipment life, and maintains even, comfortable temperatures. Please contact your local ICP representative for assistance.

### Low ambient applications

The optional ICP economizer can adequately cool your space by bringing in fresh, cool outside air. In fact, when so equipped, accessory low-ambient kit may not be necessary. In low ambient conditions, unless the outdoor air is excessively humid or contaminated, economizer-based "free cooling" is the preferred less costly and energy conscious method.

In low ambient applications where outside air might not be desired (such as contaminated or excessively humid outdoor environments), your ICP rooftop can operate to ambient temperatures down to -20°F (-29°C) using the recommended field installed accessory Motormaster low ambient controller or 0°F (-18°C) with the factory installed low ambient controller option.

### 2-Speed Indoor Fan Motor System with Variable Frequency Drive (VFD)

The 2-Speed Indoor Fan Motor system utilizes a Variable Frequency Drive (VFD) to automatically adjust the indoor fan motor speed in sequence with the units cooling operation. Per ASHRAE 90.1-2013 standard, during the first stage of cooling operation the VFD will adjust the fan motor to provide 66% of the total cfm established for the unit. When a call for the second stage of cooling is required, the VFD will allow the total cfm for the unit established (100%). During the heating mode, the VFD will allow total design cfm (100%) operation and during the ventilation mode the VFD will allow operation to 66% of total cfm.

The VFD used in the 2-Speed Indoor Fan Motor system has soft start capabilities to slowly ramp up the speeds, thus eliminating any high inrush air volume during initial start-up. It also has internal over current protection for the fan motor and a field-installed display kit that allows adjustment and in depth diagnostics of the VFD.

This 2-Speed Indoor Fan Motor system is available on models with 2-stage cooling operation with electro-mechanical controls. Both space sensor and conventional thermostat controls can be used to provide accurate control in any application.

The 2-Speed Indoor Fan Motor system is very flexible for initial fan performance set up and adjustment. The standard factory shipped VFD is pre-programmed to automatically stage the fan speed between the first and second stage of cooling. The unit fan performance static pressure and cfm can be easily adjusted using the traditional means of pulley adjustments. The other means to adjust the unit static and cfm performance is to utilize the field-installed display module and adjust the frequency and voltage in the VFD to required performance requirements. In either case, once set up the VFD will automatically adjust the speed between the cooling stage operations.

### RGH - 2-Speed Indoor Fan Motor - Variable Frequency Drive (VFD) HP Rating

Unit Size	VOLTAGE	STATIC OPTION	VFD HP RATING
073	208/230, 460, 575	STD	3
	208/230, 460	MED	3
	575	MED	5
	208/230, 460, 575	HIGH	7.5
090	208/230, 460, 575	STD	3
	208/230, 460, 575	MED	3
	208/230, 460, 575	HIGH	7.5
102	208/230, 460, 575	STD	3
	208/230, 460, 575	MED	3
	208/230, 460, 575	HIGH	5
110	208/230, 460, 575	STD	3
	208/230, 460, 575	MED	5
	208/230, 460, 575	HIGH	7.5
120	208/230, 460, 575	STD	3
	208/230, 460, 575	MED	5
	208/230, 460, 575	HIGH	7.5
150	208/230, 460	STD	3
	575	STD	5
	208/230, 460, 575	MED	5
	208/230, 460, 575	HIGH	7.5

# SELECTION PROCEDURE (WITH RGH072 EXAMPLE)<sup>1</sup>

## I. Determine cooling and heating loads.

### Given:

Mixed air dry bulb	80°F (27°C)
Mixed air wet bulb	67°F (19°C)
Ambient dry bulb	95°F (35°C)
TC <sub>Load</sub>	72.0 MBH
SHC <sub>Load</sub>	54.0 MBH
Vertical supply air	2100 CFM
Heating load	85.0 MBH
External static pressure	0.67 in. wg
Electrical characteristics	230-3-60

## II. Make an initial guess at cooling tons.

Refrig. tons = TC<sub>Load</sub> / 12 MBH per ton  
 Refrig. tons = 72.0 / 12 = 6.0 tons  
 In this case, start by looking at the RGH072.

## III. Look up the rooftop's TC and SHC.

Table 18 shows that, at the application's supply air CFM, mixed air and ambient temperatures, the RGH072 supplies:  
 TC = 73.6 MBH<sup>2</sup>  
 SHC = 53.3 MBH<sup>2</sup>

## IV. Calculate the building latent heat load.

LC<sub>Load</sub> = TC<sub>Load</sub> - SHC<sub>Load</sub>  
 LC<sub>Load</sub> = 72.0 MBH - 54.0 MBH = 18.0 MBH

## V. Calculate RTU latent heat capacity.

LC = TC - SHC  
 LC = 73.6 MBH - 53.3 MBH = 20.3 MBH

## VI. Compare RTU capacities to loads.<sup>3</sup>

Compare the rooftop's SHC and LC to the building's sensible and latent heat loads.

### Legend

BHP	— Break horsepower
FLA	— Full load amps
LC	— Latent capacity
LRA	— Lock rotor amp
MBH	— (1,000) BTUH
MCA	— Min. circuit ampacity
MOCP	— Max. over-current protection
RPM	— Revolutions per minute
RTU	— Rooftop unit
SHC	— Sensible heat capacity
TC	— Total capacity

## VII. Select factory options (FIOP)

Local code requires an economizer for any unit with TC greater than 65.0 MBH.

## VIII. Calculate the total static pressure.

External static pressure	0.67 in. wg
Sum of FIOP / Accessory static	+0.13 in. wg
Total Static Pressure	0.80 in. wg

## IX. Look up the indoor fan RPM & BHP.

Table 45 shows, at 2100 CFM & ESP= 0.8, RPM = 712 & BHP = 1.17

## X. Convert BHP (Step VIII) into fan motor heat.

Fan motor heat = 2.546\* BHP/Motor Eff.<sup>4</sup>  
 Fan motor heat = 3.7 MBH

## XI. Calculate RTU heating capacity.

Building heating load	85.0 MBH
Fan motor heat	-3.7 MBH
Required heating capacity	81.3 MBH

## XII. Select a gas heater.

Table 4 shows the heating capacities of the RGH072 = 103.0 MBH. Select the RGH072

## XIII. Determine electrical requirements.

MCA/MOCP tables show the MCA and Breaker Size of a RGH072 (without convenience outlet) as:  
 MCA = 32.0 amps & MOCP = 50.0 amps  
 Min. disconnect size: FLA = 31.0 & LRA = 148.

### NOTES:

1. Selection software by ICP saves time by performing many of the steps above. Contact your ICP sales representative for assistance.
2. Unit ratings are gross capacities and do not include the effect of evaporator fan motor heat. See Step XI. for determining amount of evaporator fan motor heat to subtract from total and sensible capacities to obtain net cooling and net sensible capacities.
3. Selecting a unit with a SHC slightly lower than the SHC<sub>Load</sub> is often better than oversizing. Slightly lower SHC's will help control indoor humidity, and prevent temperature swings.
4. Indoor fan motor efficiency is available in Electrical Information. Use the decimal form in the equation, eg. 80% = .8.

**Table 12 – COOLING CAPACITIES**

**1-STAGE COOLING**

**3 TONS**

RGH036			AMBIENT TEMPERATURE (F)																
			85			95			105			115			125				
			EAT (db)			EAT (db)			EAT (db)			EAT (db)			EAT (db)				
			75	80	85	75	80	85	75	80	85	75	80	85	75	80	85		
900 Cfm	EAT (wb)	58	TC	32.1	32.1	36.3	30.8	30.8	34.9	29.4	29.4	33.4	28.0	28.0	31.7	26.3	26.3	29.8	
			SHC	27.8	32.1	36.3	26.7	30.8	34.9	25.5	29.4	33.4	24.2	28.0	31.7	22.8	26.3	29.8	
		62	TC	34.0	34.0	34.3	32.3	32.3	33.5	30.6	30.6	32.6	28.7	28.7	31.7	26.6	26.6	30.6	
			SHC	25.0	29.7	34.3	24.2	28.9	33.5	23.4	28.0	32.6	22.5	27.1	31.7	21.5	26.0	30.6	
		67	TC	37.3	37.3	37.3	35.5	35.5	35.5	33.6	33.6	33.6	31.5	31.5	31.5	29.2	29.2	29.2	
			SHC	20.7	25.4	30.0	20.0	24.6	29.3	19.2	23.8	28.4	18.3	22.9	27.6	17.4	22.0	26.6	
	72	TC	40.8	40.8	40.8	38.9	38.9	38.9	36.9	36.9	36.9	34.6	34.6	34.6	32.2	32.2	32.2		
		SHC	16.3	21.0	25.7	15.6	20.3	25.0	14.8	19.5	24.1	13.9	18.6	23.3	13.0	17.7	22.3		
	76	TC	-	43.9	43.9	-	41.8	41.8	-	39.6	39.6	-	37.2	37.2	-	34.6	34.6		
		SHC	-	17.4	22.4	-	16.7	21.7	-	15.9	20.8	-	15.1	19.9	-	14.2	19.0		
	1050 Cfm	EAT (wb)	58	TC	33.8	33.8	38.4	32.5	32.5	36.8	31.0	31.0	35.1	29.4	29.4	33.3	27.6	27.6	31.3
				SHC	29.3	33.8	38.4	28.1	32.5	36.8	26.9	31.0	35.1	25.5	29.4	33.3	23.9	27.6	31.3
62			TC	35.1	35.1	37.5	33.3	33.3	36.6	31.5	31.5	35.7	29.6	29.6	34.5	27.7	27.7	32.6	
			SHC	26.9	32.2	37.5	26.0	31.3	36.6	25.1	30.4	35.7	24.1	29.3	34.5	22.7	27.7	32.6	
67			TC	38.4	38.4	38.4	36.5	36.5	36.5	34.5	34.5	34.5	32.3	32.3	32.3	29.9	29.9	29.9	
			SHC	22.0	27.3	32.7	21.2	26.5	31.9	20.3	25.7	31.0	19.4	24.8	30.1	18.5	23.8	29.1	
72		TC	42.0	42.0	42.0	40.0	40.0	40.0	37.8	37.8	37.8	35.5	35.5	35.5	32.9	32.9	32.9		
		SHC	16.9	22.3	27.6	16.1	21.5	26.9	15.3	20.7	26.0	14.4	19.8	25.1	13.5	18.8	24.2		
76		TC	-	45.0	45.0	-	42.9	42.9	-	40.6	40.6	-	38.0	38.0	-	35.3	35.3		
		SHC	-	18.1	23.8	-	17.4	23.0	-	16.6	22.2	-	15.7	21.3	-	14.8	20.3		
1200 Cfm		EAT (wb)	58	TC	35.3	35.3	40.0	33.9	33.9	38.4	32.3	32.3	36.6	30.6	30.6	34.7	28.7	28.7	32.5
				SHC	30.6	35.3	40.0	29.4	33.9	38.4	28.0	32.3	36.6	26.5	30.6	34.7	24.9	28.7	32.5
	62		TC	35.9	35.9	40.5	34.2	34.2	39.4	32.4	32.4	38.1	30.6	30.6	36.1	28.7	28.7	33.9	
			SHC	28.6	34.5	40.5	27.7	33.6	39.4	26.6	32.4	38.1	25.2	30.6	36.1	23.6	28.7	33.9	
	67		TC	39.3	39.3	39.3	37.3	37.3	37.3	35.2	35.2	35.2	32.9	32.9	32.9	30.5	30.5	31.6	
			SHC	23.1	29.1	35.2	22.3	28.3	34.4	21.4	27.5	33.5	20.5	26.6	32.6	19.5	25.6	31.6	
	72	TC	42.9	42.9	42.9	40.8	40.8	40.8	38.5	38.5	38.5	36.1	36.1	36.1	33.4	33.4	33.4		
		SHC	17.3	23.4	29.5	16.6	22.6	28.7	15.7	21.8	27.9	14.8	20.9	27.0	13.9	19.9	26.0		
	76	TC	-	45.9	45.9	-	43.7	43.7	-	41.3	41.3	-	38.7	38.7	-	35.9	35.9		
		SHC	-	18.8	25.1	-	18.0	24.3	-	17.2	23.4	-	16.3	22.5	-	15.4	21.5		
	1350 Cfm	EAT (wb)	58	TC	36.6	36.6	41.5	35.1	35.1	39.7	33.4	33.4	37.9	31.6	31.6	35.8	29.6	29.6	33.6
				SHC	31.7	36.6	41.5	30.4	35.1	39.7	28.9	33.4	37.9	27.4	31.6	35.8	25.7	29.6	33.6
62			TC	36.7	36.7	43.2	35.1	35.1	41.3	33.4	33.4	39.4	31.6	31.6	37.3	29.6	29.6	34.9	
			SHC	30.2	36.7	43.2	28.8	35.1	41.3	27.5	33.4	39.4	26.0	31.6	37.3	24.4	29.6	34.9	
67			TC	39.9	39.9	39.9	37.9	37.9	37.9	35.8	35.8	35.9	33.4	33.4	34.9	30.9	30.9	33.9	
			SHC	24.2	30.9	37.6	23.4	30.1	36.8	22.5	29.2	35.9	21.6	28.3	34.9	20.6	27.2	33.9	
72		TC	43.6	43.6	43.6	41.4	41.4	41.4	39.1	39.1	39.1	36.6	36.6	36.6	33.9	33.9	33.9		
		SHC	17.8	24.5	31.3	17.0	23.7	30.5	16.1	22.9	29.6	15.2	22.0	28.7	14.3	21.0	27.7		
76		TC	-	46.7	46.7	-	44.4	44.4	-	41.9	41.9	-	39.2	39.2	-	36.3	36.3		
		SHC	-	19.4	26.3	-	18.6	25.5	-	17.8	24.6	-	16.9	23.7	-	15.9	22.7		
1500 Cfm		EAT (wb)	58	TC	37.7	37.7	42.7	36.1	36.1	40.9	34.3	34.3	38.9	32.5	32.5	36.8	30.4	30.4	34.4
				SHC	32.6	37.7	42.7	31.3	36.1	40.9	29.8	34.3	38.9	28.1	32.5	36.8	26.3	30.4	34.4
	62		TC	37.7	37.7	44.4	36.1	36.1	42.5	34.4	34.4	40.5	32.5	32.5	38.3	30.4	30.4	35.8	
			SHC	31.0	37.7	44.4	29.7	36.1	42.5	28.3	34.4	40.5	26.7	32.5	38.3	25.0	30.4	35.8	
	67		TC	40.5	40.5	40.5	38.4	38.4	39.1	36.2	36.2	38.2	33.8	33.8	37.2	31.2	31.2	36.1	
			SHC	25.2	32.6	40.0	24.4	31.7	39.1	23.5	30.8	38.2	22.5	29.9	37.2	21.5	28.8	36.1	
	72	TC	44.2	44.2	44.2	41.9	41.9	41.9	39.6	39.6	39.6	37.0	37.0	37.0	34.2	34.2	34.2		
		SHC	18.2	25.6	33.0	17.4	24.8	32.2	16.5	23.9	31.3	15.6	23.0	30.4	14.7	22.0	29.4		
	76	TC	-	47.2	47.2	-	44.9	44.9	-	42.3	42.3	-	39.6	39.6	-	36.7	36.7		
		SHC	-	19.9	27.5	-	19.1	26.7	-	18.3	25.8	-	17.4	24.9	-	16.4	23.9		

**LEGEND:**

- Do not operate
- Cfm - Cubic feet per minute (supply air)
- EAT(db) - Entering air temperature (dry bulb)
- EAT(wb) - Entering air temperature (wet bulb)
- SHC - Sensible heat capacity (1000 Btuh) Gross
- TC - Total capacity (1000 Btuh) Gross

**NOTE:** See Minimum-Maximum Airflow Ratings in Table 7. Do not operate outside these limits.

**Table 13 – COOLING CAPACITIES**

**1-Stage Cooling**

**3 TONS (cont)**

RGH036 (3 TONS) - UNIT WITH HOT GAS RE-HEAT SYSTEM IN SUBCOOLING MODE										
Temp (F) Air Entering Condenser (Edb)		AIR ENTERING EVAPORATOR - CFM								
		900			1200			1500		
		Air Entering Evaporator - Ewb (F)								
		72	67	62	72	67	62	72	67	62
75	TC	44.6	40.3	36.5	47.0	43.0	39.1	48.8	44.3	40.8
	SHC	19.8	24.5	29.3	22.6	29.1	35.3	25.4	33.0	40.4
	kW	2.02	1.97	1.93	1.96	2.00	2.05	2.08	2.02	1.98
85	TC	42.1	38.1	34.4	44.6	40.5	36.9	46.1	41.9	38.6
	SHC	17.5	22.5	27.4	20.4	26.8	33.2	22.9	30.8	38.2
	kW	2.28	2.23	2.19	2.22	2.26	2.31	2.33	2.28	2.24
95	TC	39.6	35.8	32.3	41.9	38.0	34.5	43.2	39.3	36.2
	SHC	15.2	20.3	25.5	17.8	24.5	31.1	20.2	28.4	35.9
	kW	2.56	2.51	2.47	2.50	2.54	2.60	2.62	2.56	2.52
105	TC	36.8	33.2	30.0	38.9	35.3	32.0	40.2	36.5	33.6
	SHC	12.7	18.1	23.4	15.1	22.0	28.8	17.5	25.8	33.6
	kW	2.88	2.83	2.79	2.82	2.86	2.91	2.93	2.88	2.84
115	TC	33.9	30.5	27.5	35.8	32.4	29.4	37.0	33.5	30.9
	SHC	10.1	15.7	21.2	12.3	19.5	26.4	14.5	23.1	30.9
	kW	3.23	3.19	3.15	3.17	3.21	3.26	3.28	3.23	3.19
125	TC	30.8	27.7	24.9	32.5	29.3	26.5	33.5	30.3	27.9
	SHC	7.3	13.1	18.9	9.4	16.7	23.9	11.4	20.3	27.9
	kW	3.62	3.59	3.56	3.57	3.60	3.65	3.66	3.62	3.59

RGH036 (3 TONS) - UNIT WITH HOT GAS RE-HEAT SYSTEM IN HOT GAS REHEAT MODE										
Temp (F) Air Entering Condenser (Edb)		AIR ENTERING EVAPORATOR (F)								
		75 Dry Bulb			75 Dry Bulb			75 Dry Bulb		
		62.5 Wet Bulb			64 Wet Bulb			65.3 Wet Bulb		
		(50% Relative)			(56% Relative)			(60% Relative)		
		Air Entering Evaporator - Cfm								
900	1200	1500	900	1200	1500	900	1200	1500		
80	TC	16.46	17.15	17.74	16.66	17.23	17.79	16.85	17.74	18.29
	SHC	5.10	6.60	8.15	3.21	4.33	5.61	1.59	2.75	3.83
	kW	1.94	2.01	2.02	2.04	2.13	2.15	2.12	2.14	2.16
75	TC	16.61	17.52	18.09	17.18	18.09	18.67	17.69	18.61	19.19
	SHC	5.24	6.96	8.48	3.71	5.15	6.45	2.40	3.59	4.69
	kW	1.98	2.00	2.01	1.99	2.01	2.02	2.00	2.02	2.03
70	TC	17.00	18.06	18.63	17.56	18.46	19.40	18.41	19.35	20.10
	SHC	5.62	7.47	9.00	4.08	5.50	7.16	3.09	4.31	5.58
	kW	1.96	1.94	1.96	1.97	2.00	1.94	1.91	1.94	1.92
60	TC	17.63	18.49	19.37	18.17	19.38	19.95	18.66	19.52	20.46
	SHC	6.21	7.89	9.71	4.66	6.39	7.68	3.31	4.45	5.90
	kW	1.93	1.96	1.92	1.95	1.92	1.94	1.97	2.00	1.96
50	TC	17.82	18.59	19.72	18.31	19.73	20.26	18.76	20.21	20.73
	SHC	6.40	7.99	10.05	4.79	6.71	7.97	3.40	5.11	6.16
	kW	1.98	2.03	1.94	2.01	1.94	1.97	2.03	1.96	1.99
40	TC	17.70	19.38	19.85	19.10	20.30	20.34	19.53	20.76	21.26
	SHC	6.30	8.74	10.17	5.54	7.26	8.05	4.13	5.64	6.67
	kW	2.07	1.95	1.99	1.93	1.91	2.02	1.96	1.94	1.97

**LEGEND**

- Edb - Entering Dry-Bulb
- Ewb - Entering Wet-Bulb
- kW - Compressor Motor Power Input
- ldb - Leaving Dry-Bulb
- lwb - Leaving Wet-Bulb
- SHC - Sensible Heat Capacity (1000 Btuh) Gross
- TC - Total Capacity (1000 Btuh) Gross

**NOTES:**

1. Direct interpolation is permissible. Do not extrapolate.
2. The following formulas may be used:

$$t_{ldb} = t_{edb} - \frac{\text{sensible capacity (Btuh)}}{1.10 \times \text{cfm}}$$

$t_{lwb}$  = Wet-bulb temperature corresponding to enthalpy of air leaving evaporator coil ( $h_{lwb}$ )

$$h_{lwb} = h_{ewb} - \frac{\text{total capacity (Btuh)}}{4.5 \times \text{cfm}}$$

Where:  $h_{ewb}$  = Enthalpy of air entering evaporator coil

**Table 14 – COOLING CAPACITIES**

**1-STAGE COOLING**

**4 TONS**

RGH048			AMBIENT TEMPERATURE (F)																
			85			95			105			115			125				
			EAT (db)			EAT (db)			EAT (db)			EAT (db)			EAT (db)				
			75	80	85	75	80	85	75	80	85	75	80	85	75	80	85		
1200 Cfm	EAT (wb)	58	TC	43.2	43.2	49.1	41.5	41.5	47.2	39.7	39.7	45.1	37.7	37.7	42.9	35.6	35.6	40.4	
			SHC	37.3	43.2	49.1	35.9	41.5	47.2	34.3	39.7	45.1	32.6	37.7	42.9	30.7	35.6	40.4	
		62	TC	45.9	45.9	46.0	43.7	43.7	45.0	41.3	41.3	43.8	38.8	38.8	42.6	36.0	36.0	41.2	
			SHC	33.5	39.8	46.0	32.5	38.7	45.0	31.3	37.6	43.8	30.1	36.3	42.6	28.8	35.0	41.2	
		67	TC	50.5	50.5	50.5	48.0	48.0	48.0	45.4	45.4	45.4	42.6	42.6	42.6	39.6	39.6	39.6	
			SHC	27.9	34.1	40.4	26.8	33.1	39.4	25.7	32.0	38.2	24.5	30.8	37.1	23.2	29.5	35.8	
	72	TC	55.4	55.4	55.4	52.7	52.7	52.7	49.9	49.9	49.9	46.8	46.8	46.8	43.5	43.5	43.5		
		SHC	22.0	28.4	34.7	21.0	27.3	33.7	19.9	26.2	32.5	18.7	25.0	31.3	17.4	23.8	30.1		
	76	TC	-	59.7	59.7	-	56.8	56.8	-	53.7	53.7	-	50.4	50.4	-	46.8	46.8		
		SHC	-	23.6	30.2	-	22.6	29.2	-	21.5	28.1	-	20.3	26.8	-	19.1	25.5		
	1400 Cfm	EAT (wb)	58	TC	45.6	45.6	51.9	43.8	43.8	49.8	41.9	41.9	47.6	39.7	39.7	45.1	37.3	37.3	42.4
				SHC	39.4	45.6	51.9	37.9	43.8	49.8	36.2	41.9	47.6	34.3	39.7	45.1	32.3	37.3	42.4
62			TC	47.4	47.4	50.5	45.1	45.1	49.3	42.6	42.6	48.0	40.0	40.0	46.5	37.4	37.4	44.2	
			SHC	36.0	43.2	50.5	34.9	42.1	49.3	33.7	40.9	48.0	32.4	39.5	46.5	30.6	37.4	44.2	
67			TC	52.1	52.1	52.1	49.5	49.5	49.5	46.7	46.7	46.7	43.7	43.7	43.7	40.5	40.5	40.5	
			SHC	29.5	36.8	44.0	28.4	35.7	42.9	27.3	34.5	41.8	26.0	33.3	40.5	24.7	32.0	39.2	
72		TC	57.1	57.1	57.1	54.3	54.3	54.3	51.2	51.2	51.2	48.0	48.0	48.0	44.5	44.5	44.5		
		SHC	22.8	30.1	37.4	21.7	29.0	36.3	20.5	27.8	35.1	19.3	26.6	33.9	18.0	25.3	32.6		
76		TC	-	61.4	61.4	-	58.3	58.3	-	55.1	55.1	-	51.6	51.6	-	47.8	47.8		
		SHC	-	24.6	32.2	-	23.5	31.1	-	22.4	29.9	-	21.2	28.7	-	19.9	27.4		
1600 Cfm		EAT (wb)	58	TC	47.7	47.7	54.2	45.8	45.8	52.0	43.7	43.7	49.6	41.3	41.3	47.0	38.8	38.8	44.1
				SHC	41.2	47.7	54.2	39.5	45.8	52.0	37.7	43.7	49.6	35.7	41.3	47.0	33.5	38.8	44.1
	62		TC	48.7	48.7	54.5	46.3	46.3	53.2	43.7	43.7	51.7	41.4	41.4	48.9	38.8	38.8	45.9	
			SHC	38.3	46.4	54.5	37.1	45.2	53.2	35.8	43.7	51.7	33.9	41.4	48.9	31.8	38.8	45.9	
	67		TC	53.3	53.3	53.3	50.6	50.6	50.6	47.7	47.7	47.7	44.6	44.6	44.6	41.2	41.2	42.6	
			SHC	31.0	39.2	47.5	29.9	38.1	46.3	28.7	37.0	45.2	27.5	35.7	43.9	26.2	34.4	42.6	
	72	TC	58.4	58.4	58.4	55.4	55.4	55.4	52.3	52.3	52.3	48.9	48.9	48.9	45.2	45.2	45.2		
		SHC	23.4	31.7	39.9	22.3	30.6	38.8	21.1	29.4	37.6	19.9	28.2	36.4	18.6	26.8	35.1		
	76	TC	-	62.7	62.7	-	59.5	59.5	-	56.1	56.1	-	52.5	52.5	-	48.6	48.6		
		SHC	-	25.5	34.0	-	24.4	32.9	-	23.2	31.7	-	22.0	30.4	-	20.7	29.1		
	1800 Cfm	EAT (wb)	58	TC	49.5	49.5	56.2	47.4	47.4	53.9	45.2	45.2	51.3	42.7	42.7	48.5	40.1	40.1	45.5
				SHC	42.8	49.5	56.2	41.0	47.4	53.9	39.0	45.2	51.3	36.9	42.7	48.5	34.6	40.1	45.5
62			TC	49.8	49.8	58.1	47.5	47.5	56.1	45.2	45.2	53.4	42.8	42.8	50.5	40.1	40.1	47.4	
			SHC	40.4	49.2	58.1	38.8	47.5	56.1	37.0	45.2	53.4	35.0	42.8	50.5	32.8	40.1	47.4	
67			TC	54.3	54.3	54.3	51.5	51.5	51.5	48.5	48.5	48.5	45.3	45.3	47.1	41.8	41.8	45.7	
			SHC	32.5	41.7	50.8	31.4	40.5	49.7	30.2	39.3	48.5	28.9	38.0	47.1	27.5	36.6	45.7	
72		TC	59.4	59.4	59.4	56.3	56.3	56.3	53.1	53.1	53.1	49.6	49.6	49.6	45.8	45.8	45.8		
		SHC	24.0	33.2	42.4	22.9	32.1	41.3	21.7	30.9	40.1	20.4	29.6	38.8	19.1	28.3	37.5		
76		TC	-	63.8	63.8	-	60.5	60.5	-	57.0	57.0	-	53.2	53.2	-	49.2	49.2		
		SHC	-	26.3	35.8	-	25.2	34.6	-	24.0	33.4	-	22.8	32.1	-	21.5	30.8		
2000 Cfm		EAT (wb)	58	TC	51.0	51.0	58.0	48.8	48.8	55.5	46.5	46.5	52.8	43.9	43.9	49.9	41.1	41.1	46.7
				SHC	44.1	51.0	58.0	42.2	48.8	55.5	40.2	46.5	52.8	37.9	43.9	49.9	35.5	41.1	46.7
	62		TC	51.1	51.1	60.4	48.9	48.9	57.8	46.5	46.5	55.0	44.0	44.0	51.9	41.1	41.1	48.6	
			SHC	41.8	51.1	60.4	40.0	48.9	57.8	38.1	46.5	55.0	36.0	44.0	51.9	33.7	41.1	48.6	
	67		TC	55.1	55.1	55.1	52.1	52.1	52.9	49.1	49.1	51.6	45.8	45.8	50.2	42.3	42.3	48.7	
			SHC	33.9	44.0	54.1	32.7	42.8	52.9	31.5	41.5	51.6	30.2	40.2	50.2	28.8	38.8	48.7	
	72	TC	60.3	60.3	60.3	57.1	57.1	57.1	53.7	53.7	53.7	50.1	50.1	50.1	46.3	46.3	46.3		
		SHC	24.5	34.7	44.8	23.4	33.5	43.6	22.2	32.3	42.4	21.0	31.1	41.2	19.6	29.7	39.8		
	76	TC	-	64.6	64.6	-	61.2	61.2	-	57.6	57.6	-	53.8	53.8	-	49.7	49.7		
		SHC	-	27.1	37.5	-	26.0	36.3	-	24.8	35.1	-	23.5	33.8	-	22.2	32.4		

**LEGEND:**

- Do not operate
- Cfm - Cubic feet per minute (supply air)
- EAT(db) - Entering air temperature (dry bulb)
- EAT(wb) - Entering air temperature (wet bulb)
- SHC - Sensible heat capacity (1000 Btuh) Gross
- TC - Total capacity (1000 Btuh) Gross

**NOTE:** See Minimum-Maximum Airflow Ratings in Table 7. Do not operate outside these limits.

**Table 15 – COOLING CAPACITIES**

**1-STAGE COOLING**

**4 TONS (cont)**

RGH048 (4 TONS) - UNIT WITH HOT GAS RE-HEAT IN SUBCOOLING MODE										
Temp (F) Air Entering Condenser (Edb)		AIR ENTERING EVAPORATOR - CFM								
		1200			1600			2000		
		Air Entering Evaporator - Ewb (F)								
		72	67	62	72	67	62	72	67	62
75	TC	57.8	52.3	47.2	61.5	55.6	50.6	63.7	57.9	0.0
	SHC	24.2	30.5	36.8	27.9	35.9	44.0	31.2	40.9	0.0
	kW	2.50	2.47	2.44	2.46	2.48	2.51	2.53	2.50	0.00
85	TC	54.1	48.9	44.1	57.1	52.0	47.3	59.6	54.0	49.5
	SHC	20.7	27.3	33.9	23.9	32.6	41.0	27.3	37.3	47.1
	kW	2.81	2.78	2.76	2.78	2.80	2.82	2.84	2.81	2.79
95	TC	50.1	45.3	40.8	53.3	48.2	43.7	55.2	50.1	45.8
	SHC	17.0	24.0	30.9	20.4	29.1	37.7	23.3	33.6	43.6
	kW	3.16	3.14	3.12	3.13	3.15	3.18	3.19	3.16	3.14
105	TC	45.7	41.1	37.2	48.6	43.8	39.8	50.5	45.5	41.8
	SHC	12.9	20.1	27.6	16.0	25.0	34.1	19.0	29.4	39.9
	kW	3.56	3.54	3.52	3.54	3.55	3.58	3.59	3.56	3.55
115	TC	41.1	37.0	33.2	43.5	39.2	35.5	45.4	41.1	37.5
	SHC	8.7	16.4	23.9	11.3	20.7	30.1	14.3	25.4	35.8
	kW	4.02	4.01	4.00	4.00	4.01	4.03	4.04	4.03	4.01
125	TC	36.3	32.5	29.0	38.6	34.7	31.2	40.2	36.1	32.9
	SHC	4.3	12.2	20.1	6.8	16.6	26.2	9.4	20.8	31.5
	kW	4.54	4.53	4.53	4.53	4.54	4.54	4.55	4.54	4.54

RGH048 (4 TONS) - UNIT WITH HOT GAS RE-HEAT SYSTEM IN HOT GAS REHEAT MODE										
Temp (F) Air Entering Condenser (Edb)		AIR ENTERING EVAPORATOR (F)								
		75 Dry Bulb			75 Dry Bulb			75 Dry Bulb		
		62.5 Wet Bulb			64 Wet Bulb			65.3 Wet Bulb		
		(50% Relative)			(56% Relative)			(60% Relative)		
		Air Entering Evaporator - Cfm								
1200	1600	2000	1200	1600	2000	1200	1600	2000		
80	TC	18.64	19.95	20.78	19.35	20.71	21.51	20.00	21.37	22.33
	SHC	0.78	4.36	8.24	-1.95	1.01	4.29	-4.33	-1.91	0.99
	kW	2.66	2.68	2.69	2.67	2.69	2.69	2.68	2.69	2.68
75	TC	19.37	21.21	22.15	20.47	21.97	22.92	21.15	22.78	23.65
	SHC	1.48	5.52	9.49	-0.91	2.18	5.57	-3.26	-0.61	2.20
	kW	2.62	2.54	2.54	2.56	2.55	2.55	2.56	2.55	2.56
70	TC	19.92	21.63	22.64	20.77	22.52	23.61	21.70	23.39	24.26
	SHC	2.01	5.94	9.98	-0.61	2.70	6.23	-2.72	-0.02	2.78
	kW	2.60	2.56	2.54	2.58	2.54	2.53	2.54	2.52	2.54
60	TC	20.11	21.27	22.23	20.75	23.15	23.43	22.49	23.78	24.55
	SHC	2.24	5.70	9.70	-0.57	3.35	6.15	-1.95	0.40	3.13
	kW	2.69	2.74	2.73	2.72	2.58	2.68	2.56	2.60	2.63
50	TC	21.56	22.70	23.37	22.18	23.33	24.01	22.75	23.90	25.40
	SHC	3.61	7.03	10.76	0.78	3.57	6.73	-1.67	0.57	3.96
	kW	2.57	2.63	2.66	2.60	2.66	2.69	2.63	2.69	2.62
40	TC	21.67	23.23	24.04	22.76	23.82	25.57	23.28	24.34	26.13
	SHC	3.74	7.56	9.89	1.35	4.06	8.17	-1.15	1.01	4.67
	kW	2.64	2.64	2.69	2.61	2.67	2.58	2.64	2.70	2.61

**LEGEND**

- Edb - Entering Dry-Bulb
- Ewb - Entering Wet-Bulb
- kW - Compressor Motor Power Input
- ldb - Leaving Dry-Bulb
- lwb - Leaving Wet-Bulb
- SHC - Sensible Heat Capacity (1000 Btuh) Gross
- TC - Total Capacity (1000 Btuh) Gross

**NOTES:**

1. Direct interpolation is permissible. Do not extrapolate.
2. The following formulas may be used:

$$t_{ldb} = t_{edb} - \frac{\text{sensible capacity (Btuh)}}{1.10 \times \text{cfm}}$$

$t_{lwb}$  = Wet-bulb temperature corresponding to enthalpy of air leaving evaporator coil ( $h_{lwb}$ )

$$h_{lwb} = h_{ewb} - \frac{\text{total capacity (Btuh)}}{4.5 \times \text{cfm}}$$

Where:  $h_{ewb}$  = Enthalpy of air entering evaporator coil

**Table 16 – COOLING CAPACITIES**

**1-STAGE COOLING**

**5 TONS**

RGH060			AMBIENT TEMPERATURE (F)																
			85			95			105			115			125				
			EAT (db)			EAT (db)			EAT (db)			EAT (db)			EAT (db)				
			75	80	85	75	80	85	75	80	85	75	80	85	75	80	85		
1500 Cfm	EAT (wb)	58	TC	53.4	53.4	60.6	51.3	51.3	58.2	49.0	49.0	55.6	46.5	46.5	52.7	43.7	43.7	49.5	
			SHC	46.3	53.4	60.6	44.5	51.3	58.2	42.5	49.0	55.6	40.3	46.5	52.7	37.9	43.7	49.5	
		62	TC	55.6	55.6	58.2	52.9	52.9	56.9	50.0	50.0	55.5	46.9	46.9	53.9	43.8	43.8	51.6	
			SHC	42.0	50.1	58.2	40.7	48.8	56.9	39.4	47.4	55.5	37.9	45.9	53.9	36.0	43.8	51.6	
		67	TC	60.8	60.8	60.8	57.8	57.8	57.8	54.6	54.6	54.6	51.1	51.1	51.1	47.4	47.4	47.4	
			SHC	34.4	42.6	50.7	33.2	41.3	49.4	31.8	39.9	48.1	30.4	38.5	46.6	28.9	37.0	45.1	
	72	TC	66.6	66.6	66.6	63.2	63.2	63.2	59.7	59.7	59.7	55.9	55.9	55.9	51.8	51.8	51.8		
		SHC	26.7	34.8	43.0	25.4	33.6	41.7	24.1	32.2	40.4	22.6	30.8	38.9	21.1	29.3	37.4		
	76	TC	-	71.4	71.4	-	67.9	67.9	-	64.0	64.0	-	59.9	59.9	-	55.5	55.5		
		SHC	-	28.5	36.7	-	27.2	35.5	-	25.9	34.2	-	24.5	32.7	-	23.0	31.3		
	1750 Cfm	EAT (wb)	58	TC	56.3	56.3	63.8	54.0	54.0	61.2	51.5	51.5	58.3	48.7	48.7	55.2	45.7	45.7	51.8
				SHC	48.8	56.3	63.8	46.8	54.0	61.2	44.6	51.5	58.3	42.2	48.7	55.2	39.6	45.7	51.8
62			TC	57.3	57.3	64.0	54.5	54.5	62.5	51.6	51.6	60.7	48.8	48.8	57.5	45.8	45.8	53.9	
			SHC	45.3	54.7	64.0	44.0	53.3	62.5	42.4	51.6	60.7	40.1	48.8	57.5	37.6	45.8	53.9	
67			TC	62.5	62.5	62.5	59.3	59.3	59.3	55.9	55.9	55.9	52.3	52.3	52.3	48.3	48.3	49.7	
			SHC	36.6	46.0	55.4	35.3	44.7	54.1	33.9	43.3	52.7	32.4	41.8	51.3	30.9	40.3	49.7	
72		TC	68.3	68.3	68.3	64.8	64.8	64.8	61.0	61.0	61.0	57.0	57.0	57.0	52.7	52.7	52.7		
		SHC	27.5	37.0	46.5	26.2	35.7	45.2	24.9	34.4	43.8	23.4	32.9	42.4	21.9	31.4	40.8		
76		TC	-	73.2	73.2	-	69.4	69.4	-	65.4	65.4	-	61.1	61.1	-	56.5	56.5		
		SHC	-	29.7	39.3	-	28.4	38.0	-	27.1	36.7	-	25.6	35.2	-	24.1	33.7		
2000 Cfm		EAT (wb)	58	TC	58.7	58.7	66.5	56.2	56.2	63.7	53.5	53.5	60.6	50.6	50.6	57.3	47.3	47.3	53.7
				SHC	50.9	58.7	66.5	48.7	56.2	63.7	46.4	53.5	60.6	43.8	50.6	57.3	41.0	47.3	53.7
	62		TC	58.8	58.8	69.2	56.3	56.3	66.3	53.6	53.6	63.1	50.6	50.6	59.6	47.4	47.4	55.8	
			SHC	48.3	58.8	69.2	46.3	56.3	66.3	44.0	53.6	63.1	41.6	50.6	59.6	39.0	47.4	55.8	
	67		TC	63.8	63.8	63.8	60.4	60.4	60.4	56.9	56.9	57.3	53.1	53.1	55.8	49.1	49.1	54.1	
			SHC	38.6	49.3	60.1	37.3	48.0	58.7	35.9	46.6	57.3	34.4	45.1	55.8	32.8	43.4	54.1	
	72	TC	69.6	69.6	69.6	65.9	65.9	65.9	62.1	62.1	62.1	57.9	57.9	57.9	53.5	53.5	53.5		
		SHC	28.4	39.1	49.9	27.0	37.8	48.6	25.7	36.4	47.2	24.2	35.0	45.7	22.6	33.4	44.2		
	76	TC	-	74.5	74.5	-	70.6	70.6	-	66.5	66.5	-	62.0	62.0	-	-	-		
		SHC	-	30.8	41.8	-	29.5	40.4	-	28.2	39.0	-	26.7	37.6	-	-	-		
	2250 Cfm	EAT (wb)	58	TC	60.7	60.7	68.8	58.1	58.1	65.8	55.2	55.2	62.6	52.1	52.1	59.1	48.7	48.7	55.2
				SHC	52.6	60.7	68.8	50.3	58.1	65.8	47.9	55.2	62.6	45.2	52.1	59.1	42.2	48.7	55.2
62			TC	60.8	60.8	71.6	58.1	58.1	68.5	55.3	55.3	65.1	52.2	52.2	61.4	48.7	48.7	57.4	
			SHC	50.0	60.8	71.6	47.8	58.1	68.5	45.4	55.3	65.1	42.9	52.2	61.4	40.1	48.7	57.4	
67			TC	64.7	64.7	64.7	61.3	61.3	63.2	57.7	57.7	61.7	53.8	53.8	60.1	49.7	49.7	58.3	
			SHC	40.6	52.6	64.5	39.2	51.2	63.2	37.8	49.7	61.7	36.2	48.2	60.1	34.6	46.5	58.3	
72		TC	70.6	70.6	70.6	66.8	66.8	66.8	62.8	62.8	62.8	58.6	58.6	58.6	54.0	54.0	54.0		
		SHC	29.1	41.2	53.3	27.8	39.9	51.9	26.4	38.4	50.5	24.9	37.0	49.0	23.3	35.4	47.4		
76		TC	-	75.6	75.6	-	71.6	71.6	-	67.3	67.3	-	-	-	-	-	-		
		SHC	-	31.9	44.1	-	30.6	42.8	-	29.2	41.4	-	-	-	-	-	-		
2500 Cfm		EAT (wb)	58	TC	62.5	62.5	70.8	59.7	59.7	67.6	56.7	56.7	64.2	53.4	53.4	60.5	49.9	49.9	56.5
				SHC	54.1	62.5	70.8	51.7	59.7	67.6	49.1	56.7	64.2	46.3	53.4	60.5	43.2	49.9	56.5
	62		TC	62.5	62.5	73.6	59.7	59.7	70.3	56.7	56.7	66.8	53.5	53.5	63.0	49.9	49.9	58.8	
			SHC	51.4	62.5	73.6	49.1	59.7	70.3	46.6	56.7	66.8	43.9	53.5	63.0	41.0	49.9	58.8	
	67		TC	65.5	65.5	68.9	62.0	62.0	67.4	58.3	58.3	65.9	54.4	54.4	64.2	50.2	50.2	62.2	
			SHC	42.5	55.7	68.9	41.1	54.3	67.4	39.6	52.7	65.9	38.0	51.1	64.2	36.3	49.2	62.2	
	72	TC	71.4	71.4	71.4	67.5	67.5	67.5	63.4	63.4	63.4	59.1	59.1	59.1	54.4	54.4	54.4		
		SHC	29.9	43.2	56.5	28.5	41.8	55.2	27.1	40.4	53.7	25.6	38.9	52.2	24.0	37.3	50.6		
	76	TC	-	76.4	76.4	-	72.3	72.3	-	-	-	-	-	-	-	-	-		
		SHC	-	33.0	46.4	-	31.6	45.1	-	-	-	-	-	-	-	-	-		

**LEGEND:**

- Do not operate
- Cfm - Cubic feet per minute (supply air)
- EAT(db) - Entering air temperature (dry bulb)
- EAT(wb) - Entering air temperature (wet bulb)
- SHC - Sensible heat capacity (1000 Btuh) Gross
- TC - Total capacity (1000 Btuh) Gross

**NOTE:** See Minimum-Maximum Airflow Ratings in Table 7. Do not operate outside these limits.

**Table 17 – COOLING CAPACITIES**

**1-STAGE COOLING**

**5 TONS (cont)**

RGH060 (5 TONS) - UNIT WITH HOT GAS RE-HEAT IN SUBCOOLING MODE										
Temp (F) Air Entering Condenser (Edb)		AIR ENTERING EVAPORATOR - CFM								
		1500			2000			2500		
		Air Entering Evaporator - Ewb (F)								
		72	67	62	72	67	62	72	67	62
75	TC	66.9	60.3	54.8	71.0	64.4	58.6	73.5	66.9	61.6
	SHC	25.8	34.1	43.0	30.5	41.7	52.6	35.0	48.6	61.2
	kW	3.11	3.06	3.03	3.05	3.09	3.16	3.16	3.11	3.07
85	TC	62.4	56.5	51.2	66.3	60.1	54.7	68.2	62.3	57.5
	SHC	21.5	30.6	39.6	26.1	37.6	49.0	29.9	44.2	57.2
	kW	3.47	3.43	3.39	3.42	3.46	3.51	3.52	3.48	3.44
95	TC	57.8	52.3	47.3	61.3	55.6	50.6	63.5	57.7	53.2
	SHC	17.2	26.6	35.9	21.4	33.3	45.1	25.6	39.9	53.2
	kW	3.89	3.85	3.80	3.83	3.88	3.93	3.95	3.90	3.86
105	TC	52.8	47.5	42.9	55.4	50.0	45.3	58.0	52.2	47.9
	SHC	12.5	22.1	31.7	15.8	28.1	40.1	20.4	34.7	47.9
	kW	4.36	4.31	4.26	4.29	4.33	4.38	4.42	4.36	4.32
115	TC	47.4	42.8	38.6	50.1	45.2	41.1	51.8	47.1	43.4
	SHC	7.4	17.7	27.8	11.0	23.6	36.1	14.7	30.0	43.4
	kW	4.88	4.83	4.78	4.81	4.86	4.91	4.93	4.88	4.84
125	TC	41.6	37.5	33.8	44.0	39.7	35.8	45.8	41.3	38.0
	SHC	2.1	12.8	23.3	5.3	18.6	31.2	9.1	24.7	38.0
	kW	5.44	5.39	5.35	5.37	5.42	5.47	5.49	5.44	5.40

RGH060 (5 TONS) - UNIT WITH HOT GAS RE-HEAT SYSTEM IN HOT GAS REHEAT MODE										
Temp (F) Air Entering Condenser (Edb)		AIR ENTERING EVAPORATOR (F)								
		75 Dry Bulb			75 Dry Bulb			75 Dry Bulb		
		62.5 Wet Bulb			64 Wet Bulb			65.3 Wet Bulb		
		(50% Relative)			(56% Relative)			(60% Relative)		
		Air Entering Evaporator - Cfm								
1500	2000	2500	1500	2000	2500	1500	2000	2500		
80	TC	25.29	27.61	28.72	26.81	28.62	29.71	27.68	29.53	30.63
	SHC	5.06	10.68	15.86	2.37	6.73	11.22	-0.40	3.30	7.17
	kW	3.23	3.12	3.13	3.12	3.13	3.14	3.12	3.14	3.15
75	TC	26.69	28.45	29.73	27.65	29.64	30.73	28.53	30.55	31.65
	SHC	6.39	11.52	16.85	3.20	7.72	12.20	0.43	4.29	8.16
	kW	3.08	3.11	3.09	3.10	3.09	3.11	3.11	3.10	3.12
70	TC	27.04	29.08	30.15	28.29	30.04	31.09	29.13	30.91	31.97
	SHC	6.76	12.14	17.28	3.82	8.14	12.60	1.02	4.67	8.51
	kW	3.15	3.12	3.15	3.11	3.14	3.17	3.13	3.16	3.18
60	TC	27.99	29.57	31.33	28.86	30.46	32.25	29.63	32.44	33.81
	SHC	7.70	12.66	18.45	4.41	8.60	13.74	1.54	6.16	10.28
	kW	3.17	3.23	3.15	3.21	3.26	3.18	3.23	3.12	3.10
50	TC	30.09	31.66	32.64	30.93	32.57	33.53	31.73	33.38	34.35
	SHC	9.72	14.66	19.72	6.40	10.61	14.99	3.56	7.10	10.85
	kW	3.01	3.07	3.11	3.04	3.10	3.15	3.07	3.14	3.18
40	TC	28.39	30.78	32.67	31.13	32.60	34.40	31.86	33.33	36.07
	SHC	8.17	13.89	19.80	6.63	10.69	15.85	3.72	7.10	12.51
	kW	3.39	3.32	3.24	3.14	3.23	3.15	3.18	3.27	3.08

**LEGEND**

- Edb - Entering Dry-Bulb
- Ewb - Entering Wet-Bulb
- kW - Compressor Motor Power Input
- ldb - Leaving Dry-Bulb
- lwb - Leaving Wet-Bulb
- SHC - Sensible Heat Capacity (1000 Btuh) Gross
- TC - Total Capacity (1000 Btuh) Gross

**NOTES:**

1. Direct interpolation is permissible. Do not extrapolate.
2. The following formulas may be used:

$$t_{ldb} = t_{edb} - \frac{\text{sensible capacity (Btuh)}}{1.10 \times \text{cfm}}$$

$t_{lwb}$  = Wet-bulb temperature corresponding to enthalpy of air leaving evaporator coil ( $h_{lwb}$ )

$$h_{lwb} = h_{ewb} - \frac{\text{total capacity (Btuh)}}{4.5 \times \text{cfm}}$$

Where:  $h_{ewb}$  = Enthalpy of air entering evaporator coil

**Table 18 – COOLING CAPACITIES**

**1-STAGE COOLING**

**6 TONS**

RGH072			AMBIENT TEMPERATURE (F)															
			85			95			105			115			125			
			EAT (db)			EAT (db)			EAT (db)			EAT (db)			EAT (db)			
			75	80	85	75	80	85	75	80	85	75	80	85	75	80	85	
1800 Cfm	EAT (wb)	58	TC	64.1	64.1	72.5	61.8	61.8	69.9	59.2	59.2	67	56.3	56.3	63.7	53.2	53.2	60.2
			SHC	55.7	64.1	72.5	53.7	61.8	69.9	51.4	59.2	67	48.9	56.3	63.7	46.2	53.2	60.2
		62	TC	67.9	67.9	68.5	64.9	64.9	67	61.5	61.5	65.3	57.9	57.9	63.5	54	54	61.4
			SHC	50.2	59.4	68.5	48.8	57.9	67	47.1	56.2	65.3	45.4	54.4	63.5	43.4	52.4	61.4
	67	TC	74.8	74.8	74.8	71.5	71.5	71.5	67.8	67.8	67.8	63.8	63.8	63.8	59.5	59.5	59.5	
		SHC	41.8	50.9	60.1	40.3	49.5	58.7	38.8	47.9	57.1	37.1	46.2	55.4	35.3	44.4	53.6	
	72	TC	82.2	82.2	82.2	78.7	78.7	78.7	74.7	74.7	74.7	70.4	70.4	70.4	65.6	65.6	65.6	
		SHC	33	42.3	51.6	31.6	40.9	50.2	30.1	39.3	48.6	28.4	37.7	46.9	26.7	35.9	45.1	
76	TC	-	88.7	88.7	-	84.8	84.8	-	80.6	80.6	-	76	76	-	70.9	70.9		
	SHC	-	35.3	45.2	-	33.9	43.7	-	32.4	42	-	30.7	40.3	-	28.9	38.5		
2100 Cfm	EAT (wb)	58	TC	67.6	67.6	76.5	65.1	65.1	73.7	62.3	62.3	70.5	59.3	59.3	67.1	55.9	55.9	63.2
			SHC	58.7	67.6	76.5	56.6	65.1	73.7	54.1	62.3	70.5	51.5	59.3	67.1	48.5	55.9	63.2
		62	TC	70.1	70.1	74.9	67	67	73.2	63.5	63.5	71.3	59.7	59.7	69.1	56	56	65.8
			SHC	53.9	64.4	74.9	52.4	62.8	73.2	50.6	61	71.3	48.7	58.9	69.1	46.2	56	65.8
	67	TC	77.1	77.1	77.1	73.6	73.6	73.6	69.7	69.7	69.7	65.5	65.5	65.5	60.9	60.9	60.9	
		SHC	44.2	54.8	65.3	42.7	53.3	63.9	41.2	51.7	62.3	39.4	50	60.5	37.6	48.1	58.6	
	72	TC	84.7	84.7	84.7	80.9	80.9	80.9	76.8	76.8	76.8	72.2	72.2	72.2	67.2	67.2	67.2	
		SHC	34.2	44.8	55.5	32.7	43.4	54	31.1	41.8	52.4	29.5	40.1	50.7	27.6	38.2	48.8	
76	TC	-	91.3	91.3	-	87.2	87.2	-	82.7	82.7	-	77.8	77.8	-	72.5	72.5		
	SHC	-	36.7	47.8	-	35.3	46.3	-	33.7	44.7	-	32	43	-	30.2	41.1		
2400 Cfm	EAT (wb)	58	TC	70.6	70.6	79.9	68	68	76.9	65	65	73.5	61.7	61.7	69.8	58.1	58.1	65.8
			SHC	61.3	70.6	79.9	59	68	76.9	56.4	65	73.5	53.6	61.7	69.8	50.5	58.1	65.8
		62	TC	72	72	80.6	68.7	68.7	78.7	65.2	65.2	76.6	61.8	61.8	72.6	58.2	58.2	68.4
			SHC	57.3	69	80.6	55.6	67.2	78.7	53.7	65.2	76.6	50.9	61.8	72.6	48	58.2	68.4
	67	TC	78.9	78.9	78.9	75.2	75.2	75.2	71.2	71.2	71.2	66.8	66.8	66.8	62	62	63.4	
		SHC	46.5	58.4	70.3	45	56.9	68.8	43.4	55.3	67.2	41.6	53.5	65.4	39.7	51.6	63.4	
	72	TC	86.6	86.6	86.6	82.7	82.7	82.7	78.3	78.3	78.3	73.6	73.6	73.6	68.4	68.4	68.4	
		SHC	35.2	47.2	59.2	33.7	45.7	57.7	32.1	44.1	56	30.4	42.3	54.3	28.5	40.5	52.4	
76	TC	-	93.3	93.3	-	89	89	-	84.4	84.4	-	79.3	79.3	-	73.7	73.7		
	SHC	-	38	50.4	-	36.6	48.9	-	35	47.3	-	33.3	45.5	-	31.4	43.6		
2700 Cfm	EAT (wb)	58	TC	73.2	73.2	82.8	70.4	70.4	79.6	67.3	67.3	76.1	63.8	63.8	72.2	60	60	67.9
			SHC	63.6	73.2	82.8	61.1	70.4	79.6	58.4	67.3	76.1	55.4	63.8	72.2	52.1	60	67.9
		62	TC	73.7	73.7	85.5	70.5	70.5	82.8	67.3	67.3	79.1	63.9	63.9	75.1	60.1	60.1	70.6
			SHC	60.2	72.9	85.5	58.1	70.5	82.8	55.5	67.3	79.1	52.7	63.9	75.1	49.5	60.1	70.6
	67	TC	80.3	80.3	80.3	76.5	76.5	76.5	72.4	72.4	72.4	67.8	67.8	70	62.9	62.9	67.9	
		SHC	48.7	61.9	75.1	47.1	60.4	73.6	45.5	58.7	71.9	43.7	56.8	70	41.7	54.8	67.9	
	72	TC	88.2	88.2	88.2	84	84	84	79.6	79.6	79.6	74.6	74.6	74.6	69.3	69.3	69.3	
		SHC	36.1	49.4	62.7	34.6	47.9	61.2	33	46.2	59.5	31.2	44.5	57.7	29.3	42.6	55.8	
76	TC	-	94.9	94.9	-	90.4	90.4	-	85.6	85.6	-	80.4	80.4	-	74.7	74.7		
	SHC	-	39.2	52.9	-	37.7	51.4	-	36.1	49.7	-	34.4	47.9	-	32.5	46		
3000 Cfm	EAT (wb)	58	TC	75.4	75.4	85.3	72.5	72.5	82	69.2	69.2	78.3	65.6	65.6	74.2	61.7	61.7	69.8
			SHC	65.5	75.4	85.3	62.9	72.5	82	60.1	69.2	78.3	57	65.6	74.2	53.5	61.7	69.8
		62	TC	75.5	75.5	88.7	72.5	72.5	85.3	69.3	69.3	81.4	65.7	65.7	77.2	61.7	61.7	72.5
			SHC	62.2	75.5	88.7	59.8	72.5	85.3	57.1	69.3	81.4	54.1	65.7	77.2	50.9	61.7	72.5
	67	TC	81.4	81.4	81.4	77.5	77.5	78.1	73.3	73.3	76.4	68.7	68.7	74.4	63.7	63.7	72.2	
		SHC	50.7	65.2	79.7	49.2	63.7	78.1	47.5	61.9	76.4	45.6	60	74.4	43.6	57.9	72.2	
	72	TC	89.4	89.4	89.4	85.2	85.2	85.2	80.5	80.5	80.5	75.5	75.5	75.5	70.1	70.1	70.1	
		SHC	36.9	51.5	66.1	35.4	50	64.6	33.8	48.3	62.9	32	46.5	61.1	30.1	44.6	59.1	
76	TC	-	96.1	96.1	-	91.6	91.6	-	86.7	86.7	-	81.3	81.3	-	75.5	75.5		
	SHC	-	40.4	55.3	-	38.9	53.8	-	37.2	52.1	-	35.5	50.3	-	33.6	48.3		

**LEGEND:**

- Do not operate
- Cfm - Cubic feet per minute (supply air)
- EAT(db) - Entering air temperature (dry bulb)
- EAT(wb) - Entering air temperature (wet bulb)
- SHC - Sensible heat capacity (1000 Btuh) Gross
- TC - Total capacity (1000 Btuh) Gross

**NOTE:** See Minimum-Maximum Airflow Ratings in Table 7. Do not operate outside these limits.

**Table 19 – COOLING CAPACITIES**

**1-STAGE COOLING**

**6 TONS (cont)**

RGH072 (6 TONS) - UNIT WITH HOT GAS RE-HEAT SYSTEM IN SUBCOOLING MODE										
Temp (F) Air Entering Condenser (Edb)		AIR ENTERING EVAPORATOR - CFM								
		1800			2400			3000		
		Air Entering Evaporator - Ewb (F)								
		72	67	62	72	67	62	72	67	62
75	TC	85.7	77.4	70.0	91.1	82.6	74.9	94.5	85.7	78.4
	SHC	38.2	47.1	56.1	43.9	55.6	67.1	49.0	63.1	76.4
	kW	4.05	4.01	3.97	4.00	4.04	4.08	4.09	4.05	4.02
85	TC	80.9	73.1	66.0	85.9	77.9	70.6	89.2	80.9	73.9
	SHC	33.5	42.9	52.3	38.8	51.1	63.0	43.9	58.6	72.1
	kW	4.46	4.43	4.39	4.42	4.45	4.48	4.51	4.47	4.43
95	TC	75.7	68.4	61.7	80.6	72.9	66.0	83.6	75.7	69.1
	SHC	28.7	38.5	48.3	33.8	46.4	58.7	38.6	53.7	67.6
	kW	4.92	4.89	4.86	4.88	4.91	4.95	4.96	4.92	4.90
105	TC	70.2	63.3	57.0	74.7	67.5	61.1	77.5	70.1	64.0
	SHC	23.6	33.9	44.1	28.4	41.4	54.2	32.9	48.6	62.7
	kW	5.43	5.40	5.37	5.39	5.42	5.45	5.47	5.43	5.41
115	TC	64.3	57.8	52.0	68.4	61.7	55.7	71.0	64.1	58.3
	SHC	18.2	28.9	39.6	22.7	36.2	49.4	27.0	43.1	58.2
	kW	5.99	5.96	5.93	5.95	5.98	6.01	6.02	5.99	5.97
125	TC	57.9	52.0	46.6	61.6	55.4	49.9	64.0	57.5	52.4
	SHC	12.4	23.8	34.9	16.6	30.7	44.3	20.7	37.3	52.4
	kW	6.59	6.57	6.55	6.56	6.59	6.61	6.62	6.60	6.58

RGH072 (6 TONS) - UNIT WITH HOT GAS RE-HEAT SYSTEM IN HOT GAS REHEAT MODE										
Temp (F) Air Entering Condenser (Edb)		AIR ENTERING EVAPORATOR (F)								
		75 Dry Bulb			75 Dry Bulb			75 Dry Bulb		
		62.5 Wet Bulb			64 Wet Bulb			65.3 Wet Bulb		
		(50% Relative)			(56% Relative)			(60% Relative)		
		Air Entering Evaporator - Cfm								
1800	2400	3000	1800	2400	3000	1800	2400	3000		
80	TC	24.17	25.88	26.92	25.35	27.08	28.15	26.39	28.18	29.25
	SHC	-1.44	2.99	7.86	-5.08	-1.55	2.50	-8.25	-5.47	-2.14
	kW	4.15	4.16	4.17	4.17	4.18	4.18	4.18	4.19	4.20
75	TC	26.03	27.87	28.95	27.27	29.11	30.21	28.36	30.24	31.35
	SHC	0.43	4.97	9.86	-3.12	0.49	4.56	-6.19	-3.36	-0.03
	kW	3.96	3.97	3.98	3.98	3.99	4.00	4.00	4.01	4.01
70	TC	26.50	28.76	30.07	27.92	29.99	31.34	29.45	31.67	33.23
	SHC	0.87	5.84	10.97	-2.49	1.35	5.68	-5.06	-1.85	1.94
	kW	3.97	3.93	3.91	3.96	3.95	3.93	3.92	3.89	3.87
60	TC	27.59	29.22	30.17	28.70	30.33	31.30	31.50	31.32	32.91
	SHC	1.91	6.25	11.02	-1.79	1.63	5.57	-3.31	-2.39	1.45
	kW	3.95	3.99	4.01	3.99	4.02	4.04	4.09	4.05	4.01
50	TC	27.77	29.18	30.03	28.75	30.18	32.02	29.63	32.07	32.96
	SHC	2.03	6.18	10.85	-1.80	1.43	6.25	-5.14	-1.69	1.45
	kW	4.03	4.08	4.11	4.07	4.12	4.05	4.12	4.06	4.09
40	TC	29.02	30.38	31.46	29.96	31.32	32.09	30.79	33.49	34.34
	SHC	3.26	7.34	10.07	-0.63	2.54	6.29	-4.01	-0.30	2.80
	kW	3.96	4.02	4.08	4.01	4.08	4.11	4.06	4.00	4.03

**LEGEND**

- Edb - Entering Dry-Bulb
- Ewb - Entering Wet-Bulb
- kW - Compressor Motor Power Input
- ldb - Leaving Dry-Bulb
- lwb - Leaving Wet-Bulb
- SHC - Sensible Heat Capacity (1000 Btuh) Gross
- TC - Total Capacity (1000 Btuh) Gross

**NOTES:**

1. Direct interpolation is permissible. Do not extrapolate.
2. The following formulas may be used:

$$t_{ldb} = t_{edb} - \frac{\text{sensible capacity (Btuh)}}{1.10 \times \text{cfm}}$$

$t_{lwb}$  = Wet-bulb temperature corresponding to enthalpy of air leaving evaporator coil ( $h_{lwb}$ )

$$h_{lwb} = h_{ewb} - \frac{\text{total capacity (Btuh)}}{4.5 \times \text{cfm}}$$

Where:  $h_{ewb}$  = Enthalpy of air entering evaporator coil

**Table 20 – COOLING CAPACITIES**

**2-STAGE COOLING**

**6 TONS**

RGH073			AMBIENT TEMPERATURE (F)																
			85			95			105			115			125				
			EAT (db)			EAT (db)			EAT (db)			EAT (db)			EAT (db)				
			75	80	85	75	80	85	75	80	85	75	80	85	75	80	85		
1800 Cfm	EAT (wb)	58	THC	64.6	64.6	72.9	62	62	70.1	59.3	59.3	67	56.3	56.3	63.6	53	53	60	
			SHC	56.3	64.6	72.9	54	62	70.1	51.6	59.3	67	49	56.3	63.6	46.1	53	60	
		62	THC	68.3	68.3	68.9	65	65	67.1	61.5	61.5	65.2	57.8	57.8	63.2	53.8	53.8	60.9	
			SHC	50.8	59.8	68.9	49.1	58.1	67.1	47.3	56.3	65.2	45.3	54.3	63.2	43.2	52.1	60.9	
		67	THC	74.8	74.8	74.8	71.2	71.2	71.2	67.4	67.4	67.4	63.4	63.4	63.4	58.9	58.9	58.9	
			SHC	42	51	60.1	40.3	49.4	58.4	38.5	47.6	56.6	36.7	45.7	54.8	34.7	43.7	52.8	
	76	72	THC	82	82	82	78.1	78.1	78.1	73.9	73.9	73.9	69.4	69.4	69.4	64.7	64.7	64.7	
			SHC	33	42.1	51.3	31.3	40.5	49.6	29.6	38.7	47.9	27.7	36.8	46	25.8	34.9	44	
		76	THC	-	88	88	-	83.8	83.8	-	79.4	79.4	-	74.6	74.6	-	69.4	69.4	
			SHC	-	34.9	44.8	-	33.3	43.1	-	31.5	41.2	-	29.7	39.3	-	27.7	37.3	
	2100 Cfm	EAT (wb)	58	THC	68.1	68.1	76.8	65.3	65.3	73.7	62.3	62.3	70.3	59.1	59.1	66.7	55.6	55.6	62.8
				SHC	59.3	68.1	76.8	56.9	65.3	73.7	54.2	62.3	70.3	51.4	59.1	66.7	48.3	55.6	62.8
62			THC	70.4	70.4	75.2	66.9	66.9	73.3	63.3	63.3	71.2	59.5	59.5	68.8	55.6	55.6	65.3	
			SHC	54.5	64.9	75.2	52.7	63	73.3	50.8	61	71.2	48.6	58.7	68.8	45.9	55.6	65.3	
67			THC	77.1	77.1	77.1	73.2	73.2	73.2	69.2	69.2	69.2	64.9	64.9	64.9	60.3	60.3	60.3	
			SHC	44.5	54.9	65.4	42.8	53.2	63.6	41	51.4	61.7	39.1	49.4	59.8	37	47.4	57.8	
76		72	THC	84.3	84.3	84.3	80.2	80.2	80.2	75.8	75.8	75.8	71.1	71.1	71.1	66.1	66.1	66.1	
			SHC	34.1	44.6	55.2	32.4	42.9	53.4	30.6	41.1	51.6	28.8	39.2	49.6	26.8	37.2	47.6	
		76	THC	-	90.4	90.4	-	86	86	-	81.3	81.3	-	76.3	76.3	-	70.9	70.9	
			SHC	-	36.3	47.4	-	34.6	45.7	-	32.8	43.8	-	31	41.8	-	29	39.8	
2400 Cfm		EAT (wb)	58	THC	70.9	70.9	80	68	68	76.7	64.8	64.8	73.1	61.4	61.4	69.3	57.7	57.7	65.2
				SHC	61.8	70.9	80	59.2	68	76.7	56.4	64.8	73.1	53.4	61.4	69.3	50.2	57.7	65.2
	62		THC	72.1	72.1	80.9	68.6	68.6	78.6	64.9	64.9	76.1	61.4	61.4	72.1	57.7	57.7	67.8	
			SHC	57.9	69.4	80.9	55.9	67.3	78.6	53.7	64.9	76.1	50.8	61.4	72.1	47.7	57.7	67.8	
	67		THC	78.7	78.7	78.7	74.7	74.7	74.7	70.5	70.5	70.5	66.1	66.1	66.1	61.3	61.3	62.5	
			SHC	46.8	58.6	70.3	45.1	56.8	68.5	43.2	54.9	66.6	41.3	53	64.7	39.2	50.9	62.5	
	76	72	THC	86	86	86	81.7	81.7	81.7	77.2	77.2	77.2	72.3	72.3	72.3	67.1	67.1	67.1	
			SHC	35.2	47	58.8	33.4	45.2	57	31.6	43.4	55.1	29.7	41.4	53.1	27.7	39.4	51.1	
		76	THC	-	92.2	92.2	-	87.6	87.6	-	82.7	82.7	-	77.5	77.5	-	72	72	
			SHC	-	37.6	49.9	-	35.9	48.1	-	34.1	46.2	-	32.2	44.2	-	30.1	42.1	
	2700 Cfm	EAT (wb)	58	THC	73.3	73.3	82.7	70.2	70.2	79.3	66.9	66.9	75.5	63.3	63.3	71.5	59.4	59.4	67.1
				SHC	64	73.3	82.7	61.2	70.2	79.3	58.3	66.9	75.5	55.1	63.3	71.5	51.7	59.4	67.1
62			THC	73.6	73.6	86.1	70.3	70.3	82.3	67	67	78.5	63.4	63.4	74.3	59.5	59.5	69.8	
			SHC	61	73.6	86.1	58.2	70.3	82.3	55.4	67	78.5	52.4	63.4	74.3	49.1	59.5	69.8	
67			THC	80	80	80	75.9	75.9	75.9	71.6	71.6	71.6	67	67	69.3	62.1	62.1	67	
			SHC	49	62	75	47.2	60.2	73.2	45.4	58.3	71.3	43.4	56.3	69.3	41.3	54.1	67	
76		72	THC	87.4	87.4	87.4	83	83	83	78.3	78.3	78.3	73.3	73.3	73.3	68	68	68	
			SHC	36.1	49.2	62.2	34.3	47.4	60.4	32.5	45.5	58.5	30.6	43.5	56.5	28.5	41.4	54.3	
		76	THC	-	93.6	93.6	-	88.9	88.9	-	83.9	83.9	-	78.5	78.5	-	72.8	72.8	
			SHC	-	38.8	52.3	-	37	50.5	-	35.2	48.5	-	33.2	46.5	-	31.2	44.3	
3000 Cfm		EAT (wb)	58	THC	75.6	75.6	85.2	72.2	72.2	81.5	68.7	68.7	77.6	65	65	73.4	60.9	60.9	68.8
				SHC	65.9	75.6	85.2	62.9	72.2	81.5	59.9	68.7	77.6	56.6	65	73.4	53	60.9	68.8
	62		THC	75.6	75.6	88.5	72.3	72.3	84.6	68.8	68.8	80.6	65	65	76.3	60.9	60.9	71.5	
			SHC	62.7	75.6	88.5	59.9	72.3	84.6	57	68.8	80.6	53.8	65	76.3	50.4	60.9	71.5	
	67		THC	81.1	81.1	81.1	76.9	76.9	77.7	72.4	72.4	75.7	67.7	67.7	73.5	62.8	62.8	71.1	
			SHC	51.1	65.4	79.6	49.3	63.5	77.7	47.4	61.6	75.7	45.4	59.4	73.5	43.2	57.1	71.1	
	76	72	THC	88.6	88.6	88.6	84	84	84	79.2	79.2	79.2	74.1	74.1	74.1	68.7	68.7	68.7	
			SHC	37	51.3	65.5	35.2	49.4	63.7	33.3	47.5	61.7	31.4	45.5	59.7	29.3	43.4	57.5	
		76	THC	-	94.8	94.8	-	89.9	89.9	-	84.8	84.8	-	79.3	79.3	-	73.5	73.5	
			SHC	-	39.9	54.6	-	38.1	52.7	-	36.2	50.8	-	34.3	48.7	-	32.2	46.5	

**LEGEND:**

- Do not operate
- Cfm - Cubic feet per minute (supply air)
- EAT(db) - Entering air temperature (dry bulb)
- EAT(wb) - Entering air temperature (wet bulb)
- SHC - Sensible heat capacity (1000 Btuh) Gross
- TC - Total capacity (1000 Btuh) Gross

**NOTE:** See Minimum-Maximum Airflow Ratings in Table 7. Do not operate outside these limits.

**Table 21 – COOLING CAPACITIES**

**2-STAGE COOLING**

**6 TONS (cont)**

RGH073 (6 TONS) - UNIT WITH HOT GAS RE-HEAT SYSTEM IN SUBCOOLING MODE										
Temp (F) Air Entering Condenser (Edb)		AIR ENTERING EVAPORATOR - CFM								
		1800			2400			3000		
		Air Entering Evaporator - Ewb (F)								
		72	67	62	72	67	62	72	67	62
75	TC	83.5	75.6	68.5	88.5	76.0	72.9	91.7	83.4	76.2
	SHC	37.0	47.0	55.4	43.6	51.9	65.6	47.9	62.0	74.2
	kW	3.49	3.50	3.45	3.57	3.53	3.48	3.58	3.56	3.50
85	TC	79.0	71.5	64.7	83.6	75.5	68.7	86.4	78.5	71.8
	SHC	32.9	43.2	51.9	39.5	50.6	61.7	43.7	57.3	70.1
	kW	3.94	3.94	3.90	4.03	3.97	3.91	4.08	3.97	3.95
95	TC	73.5	67.1	60.7	70.2	71.2	64.6	81.3	73.7	67.1
	SHC	26.6	39.3	48.2	31.5	46.7	57.9	39.5	53.3	65.6
	kW	4.39	4.44	4.40	4.54	4.48	4.43	4.56	4.50	4.44
105	TC	68.6	62.6	56.5	73.3	66.3	60.1	75.7	68.4	62.6
	SHC	25.5	35.3	44.4	30.5	42.3	53.8	34.6	48.6	61.5
	kW	5.05	5.02	4.98	5.10	5.05	5.00	4.56	5.06	5.02
115	TC	64.2	57.8	55.0	67.8	61.2	55.3	75.7	63.2	57.6
	SHC	21.7	31.1	40.5	25.8	37.8	49.5	34.6	44.0	57.6
	kW	5.05	5.68	5.64	5.74	5.70	5.66	5.12	5.72	5.67
125	TC	58.8	52.8	47.4	62.1	55.8	50.3	63.6	57.6	52.4
	SHC	17.1	26.7	36.3	20.8	33.0	45.0	24.1	39.1	52.4
	kW	6.46	6.43	6.41	6.48	6.44	6.41	6.48	6.45	6.42

RGH073 (6 TONS) - UNIT WITH HOT GAS RE-HEAT SYSTEM IN HOT GAS REHEAT MODE										
Temp (F) Air Entering Condenser (Edb)		AIR ENTERING EVAPORATOR (F)								
		75 Dry Bulb			75 Dry Bulb			75 Dry Bulb		
		62.5 Wet Bulb			64 Wet Bulb			65.3 Wet Bulb		
		(50% Relative Humidity)			(56% Relative Humidity)			(60% Relative Humidity)		
		Air Entering Evaporator - Cfm								
		1800	2400	3000	1800	2400	3000	1800	2400	3000
80	TC	27.93	28.67	29.02	28.32	29.87	30.25	29.63	30.24	31.31
	SHC	6.95	10.60	14.71	2.87	6.41	9.76	0.19	2.12	5.43
	kW	3.80	3.79	3.78	3.79	3.78	3.78	3.79	3.78	3.77
75	TC	28.78	30.12	30.68	29.82	30.63	31.42	30.45	31.77	32.14
	SHC	7.76	12.01	16.31	4.30	7.17	10.89	1.00	3.59	6.24
	kW	3.80	3.79	3.78	3.79	3.78	3.78	3.79	3.78	3.77
70	TC	29.64	30.80	31.85	30.48	31.97	32.67	31.55	32.79	33.12
	SHC	8.60	12.69	17.46	4.95	8.46	12.12	2.06	4.59	7.21
	kW	3.80	3.79	3.78	3.79	3.78	3.78	3.79	3.78	3.77
60	TC	31.14	32.55	33.57	32.03	33.49	34.38	32.98	34.50	35.39
	SHC	10.05	14.38	19.13	6.45	9.96	13.79	3.45	6.26	9.41
	kW	3.80	3.79	3.78	3.79	3.78	3.78	3.79	3.78	3.77
50	TC	32.23	33.83	34.70	33.47	34.97	35.86	34.42	35.95	36.90
	SHC	11.11	15.63	20.24	7.83	11.39	15.24	4.84	7.67	10.88
	kW	3.80	3.79	3.78	3.79	3.78	3.78	3.79	3.78	3.77
40	TC	33.41	35.02	35.91	34.52	36.20	37.25	35.66	37.22	38.32
	SHC	12.24	16.78	21.43	8.85	12.58	16.58	6.03	8.90	12.27
	kW	3.80	3.79	3.78	3.79	3.78	3.78	3.79	3.78	3.77

**LEGEND**

- Edb - Entering Dry-Bulb
- Ewb - Entering Wet-Bulb
- kW - Compressor Motor Power Input
- ldb - Leaving Dry-Bulb
- lwb - Leaving Wet-Bulb
- SHC - Sensible Heat Capacity (1000 Btuh) Gross
- TC - Total Capacity (1000 Btuh) Gross

**NOTES:**

1. Direct interpolation is permissible. Do not extrapolate.
2. The following formulas may be used:

$$t_{ldb} = t_{edb} - \frac{\text{sensible capacity (Btuh)}}{1.10 \times \text{cfm}}$$

$t_{lwb}$  = Wet-bulb temperature corresponding to enthalpy of air leaving evaporator coil ( $h_{lwb}$ )

$$h_{lwb} = h_{ewb} - \frac{\text{total capacity (Btuh)}}{4.5 \times \text{cfm}}$$

Where:  $h_{ewb}$  = Enthalpy of air entering evaporator coil

**Table 22 – COOLING CAPACITIES**

**2-STAGE COOLING**

**7.5 TONS**

RGH090			AMBIENT TEMPERATURE (F)																
			85			95			105			115			125				
			EAT (db)			EAT (db)			EAT (db)			EAT (db)			EAT (db)				
			75	80	85	75	80	85	75	80	85	75	80	85	75	80	85		
2250 Cfm	EAT (wb)	58	TC	81	81	91.8	77.9	77.9	88.4	74.7	74.7	84.6	71.1	71.1	80.6	67.3	67.3	76.3	
			SHC	70.2	81	91.8	67.5	77.9	88.4	64.7	74.7	84.6	61.6	71.1	80.6	58.3	67.3	76.3	
		62	TC	85.1	85.1	87.2	81.1	81.1	85.3	76.9	76.9	83.2	72.5	72.5	81	67.8	67.8	78.5	
			SHC	63.3	75.3	87.2	61.4	73.4	85.3	59.5	71.3	83.2	57.3	69.2	81	55	66.7	78.5	
		67	TC	93.3	93.3	93.3	89	89	89	84.3	84.3	84.3	79.4	79.4	79.4	74.1	74.1	74.1	
			SHC	52.3	64.2	76.2	50.4	62.4	74.4	48.4	60.4	72.4	46.4	58.3	70.3	44.2	56.2	68.1	
	72	TC	102.3	102.3	102.3	97.5	97.5	97.5	92.5	92.5	92.5	87.1	87.1	87.1	81.3	81.3	81.3		
		SHC	40.9	53	65	39	51.1	63.1	37.1	49.2	61.2	35.1	47.1	59.1	32.9	44.9	57		
	76	TC	-	110	110	-	104.8	104.8	-	99.4	99.4	-	93.5	93.5	-	87.3	87.3		
		SHC	-	43.7	56.1	-	41.9	54.2	-	39.9	52.2	-	37.9	50.2	-	35.8	48		
	2625 Cfm	EAT (wb)	58	TC	85.4	85.4	96.9	82.1	82.1	93.1	78.6	78.6	89.1	74.7	74.7	84.7	70.5	70.5	80
				SHC	74	85.4	96.9	71.2	82.1	93.1	68.1	78.6	89.1	64.7	74.7	84.7	61.1	70.5	80
62			TC	87.8	87.8	95.7	83.7	83.7	93.6	79.3	79.3	91.3	75	75	87.8	70.6	70.6	83.2	
			SHC	68.2	82	95.7	66.2	79.9	93.6	64.1	77.7	91.3	61.3	74.6	87.8	58	70.6	83.2	
67			TC	96	96	96	91.4	91.4	91.4	86.5	86.5	86.5	81.3	81.3	81.3	75.8	75.8	75.8	
			SHC	55.4	69.3	83.2	53.5	67.4	81.2	51.5	65.4	79.2	49.4	63.2	77.1	47.2	61	74.8	
72		TC	105.2	105.2	105.2	100.1	100.1	100.1	94.8	94.8	94.8	89.1	89.1	89.1	83	83	83		
		SHC	42.3	56.2	70.2	40.4	54.3	68.2	38.4	52.3	66.2	36.3	50.2	64.1	34.1	48	61.9		
76		TC	-	112.9	112.9	-	107.5	107.5	-	101.7	101.7	-	95.6	95.6	-	89.1	89.1		
		SHC	-	45.5	59.8	-	43.6	57.8	-	41.7	55.8	-	39.6	53.7	-	37.4	51.5		
3000 Cfm		EAT (wb)	58	TC	89.2	89.2	101.1	85.6	85.6	97.1	81.8	81.8	92.8	77.7	77.7	88.1	73.2	73.2	83
				SHC	77.3	89.2	101.1	74.2	85.6	97.1	70.9	81.8	92.8	67.3	77.7	88.1	63.5	73.2	83
	62		TC	90.1	90.1	103.5	86.1	86.1	100.3	81.9	81.9	96.5	77.8	77.8	91.6	73.3	73.3	86.4	
			SHC	72.7	88.1	103.5	70.1	85.2	100.3	67.3	81.9	96.5	63.9	77.8	91.6	60.2	73.3	86.4	
	67		TC	98.1	98.1	98.1	93.3	93.3	93.3	88.2	88.2	88.2	82.8	82.8	83.6	77	77	81.3	
			SHC	58.4	74.1	89.9	56.5	72.2	87.9	54.4	70.1	85.8	52.3	67.9	83.6	50	65.6	81.3	
	72	TC	107.3	107.3	107.3	102.1	102.1	102.1	96.5	96.5	96.5	90.6	90.6	90.6	84.3	84.3	84.3		
		SHC	43.5	59.3	75.1	41.6	57.3	73.1	39.5	55.3	71.1	37.4	53.2	69	35.2	50.9	66.7		
	76	TC	-	115.2	115.2	-	109.5	109.5	-	103.5	103.5	-	97.2	97.2	-	90.4	90.4		
		SHC	-	47.2	63.2	-	45.3	61.3	-	43.3	59.3	-	41.2	57.1	-	38.9	54.8		
	3375 Cfm	EAT (wb)	58	TC	92.4	92.4	104.7	88.6	88.6	100.4	84.6	84.6	95.9	80.2	80.2	90.9	75.5	75.5	85.6
				SHC	80	92.4	104.7	76.8	88.6	100.4	73.3	84.6	95.9	69.5	80.2	90.9	65.4	75.5	85.6
62			TC	92.5	92.5	109	88.7	88.7	104.5	84.6	84.6	99.7	80.3	80.3	94.6	75.6	75.6	89	
			SHC	76	92.5	109	72.9	88.7	104.5	69.6	84.6	99.7	66	80.3	94.6	62.1	75.6	89	
67			TC	99.7	99.7	99.7	94.8	94.8	94.8	89.5	89.5	92.2	84	84	89.9	78	78	87.4	
			SHC	61.3	78.8	96.4	59.3	76.8	94.3	57.2	74.7	92.2	55	72.4	89.9	52.6	70	87.4	
72		TC	109	109	109	103.6	103.6	103.6	97.8	97.8	97.8	91.8	91.8	91.8	85.3	85.3	85.3		
		SHC	44.6	62.2	79.9	42.7	60.3	77.9	40.6	58.2	75.8	38.5	56.1	73.6	36.2	53.8	71.3		
76		TC	-	116.9	116.9	-	111.1	111.1	-	104.9	104.9	-	98.4	98.4	-	91.5	91.5		
		SHC	-	48.8	66.6	-	46.8	64.6	-	44.8	62.6	-	42.7	60.4	-	40.4	58.1		
3750 Cfm		EAT (wb)	58	TC	95.1	95.1	107.8	91.2	91.2	103.3	86.9	86.9	98.5	82.3	82.3	93.3	77.4	77.4	87.8
				SHC	82.4	95.1	107.8	79	91.2	103.3	75.3	86.9	98.5	71.3	82.3	93.3	67.1	77.4	87.8
	62		TC	95.2	95.2	112.2	91.2	91.2	107.5	87	87	102.5	82.4	82.4	97.1	77.5	77.5	91.3	
			SHC	78.2	95.2	112.2	75	91.2	107.5	71.5	87	102.5	67.7	82.4	97.1	63.7	77.5	91.3	
	67		TC	101.1	101.1	102.6	96	96	100.5	90.6	90.6	98.3	84.9	84.9	95.9	78.9	78.9	93.2	
			SHC	64	83.3	102.6	62	81.2	100.5	59.8	79.1	98.3	57.6	76.7	95.9	55.1	74.2	93.2	
	72	TC	110.4	110.4	110.4	104.8	104.8	104.8	98.9	98.9	98.9	92.7	92.7	92.7	86.1	86.1	86.1		
		SHC	45.7	65.1	84.5	43.7	63.1	82.5	41.7	61	80.4	39.5	58.8	78.2	37.2	56.5	75.9		
	76	TC	-	118.3	118.3	-	112.4	112.4	-	106	106	-	99.4	99.4	-	92.3	92.3		
		SHC	-	50.3	69.9	-	48.3	67.9	-	46.2	65.8	-	44.1	63.6	-	41.8	61.3		

**LEGEND:**

- Do not operate
- Cfm - Cubic feet per minute (supply air)
- EAT(db) - Entering air temperature (dry bulb)
- EAT(wb) - Entering air temperature (wet bulb)
- SHC - Sensible heat capacity (1000 Btuh) Gross
- TC - Total capacity (1000 Btuh) Gross

**NOTE:** See Minimum-Maximum Airflow Ratings in Table 7. Do not operate outside these limits.

**Table 23 – COOLING CAPACITIES**

**2-STAGE COOLING**

**7.5 TONS (cont)**

RGH090 (7.5 TONS) - UNIT WITH HOT GAS RE-HEAT SYSTEM IS SUBCOOLING MODE										
Temp (F) Air Entering Condenser (Edb)		AIR ENTERING EVAPORATOR - CFM								
		2250			3000			3750		
		Air Entering Evaporator - Ewb (F)								
		72	67	62	72	67	62	72	67	62
75	TC	101.9	92.9	84.0	109.6	96.3	89.9	113.6	103.0	94.5
	SHC	43.9	54.6	66.7	50.2	62.7	80.9	56.8	75.8	93.0
	kW	4.60	4.54	4.48	4.65	4.50	4.52	4.68	4.60	4.55
85	TC	96.6	87.3	78.9	102.8	92.9	84.5	106.5	96.7	88.7
	SHC	36.8	49.3	61.9	43.8	59.7	75.9	50.2	69.8	87.4
	kW	5.15	5.09	5.04	5.20	5.13	5.08	5.22	5.16	5.11
95	TC	90.2	81.4	73.5	95.7	86.8	78.8	99.4	90.1	82.7
	SHC	30.8	43.9	56.9	37.2	54.1	70.5	43.6	63.8	81.6
	kW	5.78	5.72	5.67	5.82	5.76	5.71	5.85	5.79	5.74
105	TC	83.5	75.2	67.8	88.8	80.2	72.7	92.0	83.2	76.4
	SHC	24.6	38.2	51.7	30.8	48.0	64.9	36.7	57.4	75.5
	kW	6.50	6.45	6.40	6.54	6.48	6.43	6.57	6.50	6.46
115	TC	76.3	68.7	61.8	81.1	73.2	66.3	84.1	76.0	69.7
	SHC	17.9	32.1	46.2	23.7	41.5	59.0	29.4	50.7	69.0
	kW	7.32	7.28	7.24	7.35	7.31	7.27	7.38	7.32	7.29
125	TC	68.6	61.6	55.4	73.0	65.7	59.3	75.8	68.2	62.6
	SHC	10.9	25.6	40.3	16.2	34.7	52.6	21.7	43.6	62.1
	kW	8.24	8.22	8.20	8.27	8.23	8.21	8.29	8.25	8.22

RGH090 (7.5 TONS) - UNIT WITH HOT GAS RE-HEAT SYSTEM IN HOT GAS REHEAT MODE										
Temp (F) Air Entering Condenser (Edb)		AIR ENTERING EVAPORATOR (F)								
		75 Dry Bulb			75 Dry Bulb			75 Dry Bulb		
		62.5 Wet Bulb			64 Wet Bulb			65.3 Wet Bulb		
		(50% Relative)			(56% Relative)			(60% Relative)		
		Air Entering Evaporator - Cfm								
		2250	3000	3750	2250	3000	3750	2250	3000	3750
80	TC	24.06	26.14	27.48	25.50	27.56	28.78	26.59	28.71	29.96
	SHC	-5.55	1.16	8.38	-10.20	-4.69	1.40	-14.39	-9.85	-4.68
	kW	4.43	4.42	4.41	4.40	4.41	4.42	4.42	4.43	4.44
75	TC	24.87	27.26	28.47	26.06	28.53	30.02	27.67	29.77	31.02
	SHC	-4.77	2.23	9.32	-9.65	-3.76	2.59	-13.35	-8.83	-3.66
	kW	4.42	4.36	4.38	4.45	4.38	4.36	4.36	4.39	4.40
70	TC	25.16	27.88	28.56	26.72	29.10	30.26	28.17	30.20	31.83
	SHC	-4.48	2.84	9.45	-9.02	-3.19	2.85	-12.88	-8.40	-2.87
	kW	4.49	4.38	4.48	4.44	4.41	4.44	4.40	4.44	4.40
60	TC	26.43	28.14	29.14	27.49	29.24	30.27	28.50	30.24	32.33
	SHC	-3.25	3.14	10.05	-8.26	-2.99	2.94	-12.54	-8.29	-2.32
	kW	4.48	4.55	4.59	4.53	4.60	4.65	4.58	4.65	4.54
50	TC	27.19	29.55	31.26	28.94	30.59	32.36	30.54	31.54	32.52
	SHC	-2.50	4.50	12.05	-6.87	-1.69	4.92	-10.60	-7.02	-2.07
	kW	4.53	4.51	4.46	4.48	4.57	4.52	4.43	4.63	4.70
40	TC	27.92	31.58	32.82	28.81	32.60	33.54	31.82	33.50	34.44
	SHC	-1.79	6.42	10.84	-6.94	0.23	6.05	-9.36	-5.15	-0.25
	kW	4.57	4.37	4.46	4.65	4.45	4.51	4.40	4.51	4.58

**LEGEND**

- Edb - Entering Dry-Bulb
- Ewb - Entering Wet-Bulb
- kW - Compressor Motor Power Input
- ldb - Leaving Dry-Bulb
- lwb - Leaving Wet-Bulb
- SHC - Sensible Heat Capacity (1000 Btuh) Gross
- TC - Total Capacity (1000 Btuh) Gross

**NOTES:**

1. Direct interpolation is permissible. Do not extrapolate.
2. The following formulas may be used:

$$t_{ldb} = t_{edb} - \frac{\text{sensible capacity (Btuh)}}{1.10 \times \text{cfm}}$$

$t_{lwb}$  = Wet-bulb temperature corresponding to enthalpy of air leaving evaporator coil ( $h_{lwb}$ )

$$h_{lwb} = h_{ewb} - \frac{\text{total capacity (Btuh)}}{4.5 \times \text{cfm}}$$

Where:  $h_{ewb}$  = Enthalpy of air entering evaporator coil

**Table 24 – COOLING CAPACITIES**

**2-STAGE COOLING**

**8.5 TONS**

RGH102			AMBIENT TEMPERATURE (F)																
			85			95			105			115			125				
			EAT (db)			EAT (db)			EAT (db)			EAT (db)			EAT (db)				
			75	80	85	75	80	85	75	80	85	75	80	85	75	80	85		
2550 Cfm	EAT (wb)	58	TC	90.5	90.5	102.4	87	87	98.5	83.2	83.2	94.2	79.1	79.1	89.6	74.7	74.7	84.6	
			SHC	78.6	90.5	102.4	75.5	87	98.5	72.2	83.2	94.2	68.7	79.1	89.6	64.8	74.7	84.6	
		62	TC	94.8	94.8	98.1	90.2	90.2	95.8	85.4	85.4	93.4	80.3	80.3	90.8	74.9	74.9	87.8	
			SHC	71.2	84.6	98.1	69.1	82.4	95.8	66.8	80.1	93.4	64.3	77.5	90.8	61.6	74.7	87.8	
		67	TC	104	104	104	99	99	99	93.7	93.7	93.7	88	88	88	81.9	81.9	81.9	
			SHC	58.7	72.2	85.7	56.6	70	83.5	54.3	67.8	81.3	52	65.4	78.9	49.5	62.9	76.4	
	72	TC	114	114	114	108.5	108.5	108.5	102.7	102.7	102.7	96.5	96.5	96.5	89.8	89.8	89.8		
		SHC	45.8	59.3	72.9	43.7	57.2	70.8	41.4	55	68.5	39.1	52.7	66.2	36.7	50.2	63.7		
	76	TC	-	122.4	122.4	-	116.5	116.5	-	110.3	110.3	-	103.7	103.7	-	96.5	96.5		
		SHC	-	48.8	62.8	-	46.7	60.6	-	44.5	58.4	-	42.2	56	-	39.8	53.5		
	2975 Cfm	EAT (wb)	58	TC	95.4	95.4	108	91.6	91.6	103.7	87.5	87.5	99	83.1	83.1	94	78.3	78.3	88.6
				SHC	82.8	95.4	108	79.5	91.6	103.7	75.9	87.5	99	72.1	83.1	94	68	78.3	88.6
62			TC	97.7	97.7	107.4	93	93	104.9	88.1	88.1	102.1	83.2	83.2	97.9	78.4	78.4	92.2	
			SHC	76.7	92	107.4	74.3	89.6	104.9	71.8	86.9	102.1	68.6	83.2	97.9	64.6	78.4	92.2	
67			TC	106.9	106.9	106.9	101.6	101.6	101.6	96	96	96	90.1	90.1	90.1	83.7	83.7	83.9	
			SHC	62.3	77.8	93.4	60.1	75.6	91.2	57.8	73.3	88.9	55.4	70.9	86.5	52.8	68.3	83.9	
72		TC	117	117	117	111.2	111.2	111.2	105.1	105.1	105.1	98.6	98.6	98.6	91.7	91.7	91.7		
		SHC	47.3	62.9	78.6	45.1	60.8	76.4	42.9	58.5	74.1	40.5	56.1	71.7	38	53.6	69.2		
76		TC	-	125.6	125.6	-	119.4	119.4	-	112.8	112.8	-	105.9	105.9	-	98.4	98.4		
		SHC	-	50.8	66.8	-	48.7	64.6	-	46.4	62.3	-	44.1	59.9	-	41.6	57.4		
3400 Cfm		EAT (wb)	58	TC	99.5	99.5	112.7	95.4	95.4	108	91	91	103	86.3	86.3	97.7	81.2	81.2	91.9
				SHC	86.4	99.5	112.7	82.8	95.4	108	79	91	103	74.9	86.3	97.7	70.5	81.2	91.9
	62		TC	100.3	100.3	115.8	95.6	95.6	112.4	91.2	91.2	107.2	86.4	86.4	101.6	81.3	81.3	95.6	
			SHC	81.5	98.6	115.8	78.7	95.6	112.4	75.1	91.2	107.2	71.2	86.4	101.6	67	81.3	95.6	
	67		TC	109.1	109.1	109.1	103.6	103.6	103.6	97.8	97.8	97.8	91.6	91.6	93.7	85	85	90.9	
			SHC	65.6	83.2	100.8	63.4	81	98.6	61	78.6	96.2	58.6	76.1	93.7	55.9	73.4	90.9	
	72	TC	119.3	119.3	119.3	113.3	113.3	113.3	107	107	107	100.3	100.3	100.3	93	93	93		
		SHC	48.7	66.4	84.1	46.5	64.2	81.8	44.2	61.8	79.5	41.8	59.4	77.1	39.2	56.9	74.5		
	76	TC	-	128	128	-	121.5	121.5	-	114.7	114.7	-	107.5	107.5	-	99.8	99.8		
		SHC	-	52.6	70.6	-	50.5	68.4	-	48.2	66.1	-	45.8	63.6	-	43.3	61.1		
	3825 Cfm	EAT (wb)	58	TC	103	103	116.6	98.7	98.7	111.7	94	94	106.4	89	89	100.8	83.6	83.6	94.7
				SHC	89.4	103	116.6	85.6	98.7	111.7	81.6	94	106.4	77.3	89	100.8	72.6	83.6	94.7
62			TC	103.1	103.1	121.3	98.8	98.8	116.1	94.1	94.1	110.7	89.1	89.1	104.8	83.7	83.7	98.4	
			SHC	85	103.1	121.3	81.4	98.8	116.1	77.5	94.1	110.7	73.4	89.1	104.8	69	83.7	98.4	
67			TC	110.9	110.9	110.9	105.2	105.2	105.7	99.2	99.2	103.2	92.9	92.9	100.5	86.1	86.1	97.6	
			SHC	68.8	88.4	108	66.5	86.1	105.7	64.1	83.7	103.2	61.6	81.1	100.5	58.9	78.3	97.6	
72		TC	121.2	121.2	121.2	114.9	114.9	114.9	108.4	108.4	108.4	101.5	101.5	101.5	94.1	94.1	94.1		
		SHC	50	69.7	89.4	47.7	67.4	87.1	45.4	65.1	84.7	43	62.6	82.3	40.4	60	79.6		
76		TC	-	129.8	129.8	-	123.2	123.2	-	116.2	116.2	-	108.8	108.8	-	100.9	100.9		
		SHC	-	54.4	74.3	-	52.2	72.1	-	49.9	69.7	-	47.5	67.3	-	44.9	64.7		
4250 Cfm		EAT (wb)	58	TC	106	106	119.9	101.4	101.4	114.8	96.6	96.6	109.3	91.3	91.3	103.4	85.7	85.7	97
				SHC	92	106	119.9	88	101.4	114.8	83.8	96.6	109.3	79.3	91.3	103.4	74.4	85.7	97
	62		TC	106.1	106.1	124.7	101.5	101.5	119.4	96.6	96.6	113.6	91.4	91.4	107.5	85.7	85.7	100.8	
			SHC	87.4	106.1	124.7	83.6	101.5	119.4	79.6	96.6	113.6	75.3	91.4	107.5	70.6	85.7	100.8	
	67		TC	112.3	112.3	114.9	106.5	106.5	112.5	100.4	100.4	109.9	93.9	93.9	107	87.1	87.1	103.8	
			SHC	71.8	93.4	114.9	69.5	91	112.5	67	88.5	109.9	64.4	85.7	107	61.6	82.7	103.8	
	72	TC	122.6	122.6	122.6	116.2	116.2	116.2	109.5	109.5	109.5	102.5	102.5	102.5	94.9	94.9	94.9		
		SHC	51.2	72.8	94.5	48.9	70.5	92.2	46.6	68.2	89.8	44.1	65.7	87.3	41.5	63.1	84.6		
	76	TC	-	131.3	131.3	-	124.5	124.5	-	117.4	117.4	-	109.8	109.8	-	101.8	101.8		
		SHC	-	56	77.9	-	53.8	75.6	-	51.5	73.3	-	49.1	70.8	-	46.5	68.1		

**LEGEND:**

- Do not operate
- Cfm - Cubic feet per minute (supply air)
- EAT(db) - Entering air temperature (dry bulb)
- EAT(wb) - Entering air temperature (wet bulb)
- SHC - Sensible heat capacity (1000 Btuh) Gross
- TC - Total capacity (1000 Btuh) Gross

**NOTE:** See Minimum-Maximum Airflow Ratings in Table 7. Do not operate outside these limits.

**Table 25 – COOLING CAPACITIES**

**2-STAGE COOLING**

**8.5 TONS (cont)**

RGH102 (8.5 TONS) - UNIT WITH HOT GAS RE-HEAT SYSTEM IN SUBCOOLING MODE										
Temp (F) Air Entering Condenser (Edb)		AIR ENTERING EVAPORATOR - CFM								
		2550			3400			4250		
		Air Entering Evaporator - Ewb (F)								
		72	67	62	72	67	62	72	67	62
75	TC	114.7	103.9	93.9	104.3	110.6	100.5	122.9	114.6	105.5
	SHC	48.7	62.2	75.7	84.7	74.2	91.4	60.6	85.1	103.9
	kW	5.17	5.09	5.01	5.10	5.14	5.07	5.20	5.18	5.11
85	TC	107.8	97.4	88.0	114.2	102.9	94.2	116.2	107.6	98.7
	SHC	42.3	56.3	70.3	49.7	67.0	85.6	61.1	78.7	97.3
	kW	5.79	5.71	5.63	5.85	5.75	5.69	5.88	5.80	5.72
95	TC	100.5	90.8	82.0	106.6	96.2	87.7	110.2	100.1	92.2
	SHC	35.6	50.2	64.8	42.8	61.0	79.6	49.2	71.9	91.0
	kW	6.50	6.42	6.34	6.56	6.46	6.40	6.59	6.50	6.44
105	TC	92.7	83.8	75.7	98.5	89.0	80.9	102.1	92.4	85.1
	SHC	28.5	43.9	59.1	35.4	54.6	73.4	41.9	64.9	84.2
	kW	7.30	7.23	7.16	7.36	7.28	7.21	7.40	7.31	7.25
115	TC	85.0	76.5	69.0	90.0	81.3	73.8	93.3	84.4	77.7
	SHC	21.5	37.4	53.1	27.7	47.6	66.9	34.0	57.7	77.0
	kW	8.23	8.16	8.10	8.27	8.20	8.14	8.31	8.23	8.18
125	TC	76.5	68.8	61.8	81.1	72.9	66.2	84.1	75.8	69.8
	SHC	13.8	30.4	46.7	19.7	40.0	60.1	25.6	50.0	69.8
	kW	9.25	9.20	9.16	9.28	9.22	9.19	9.31	9.25	9.21

RGH102 (8.5 TONS) - UNIT WITH HOT GAS RE-HEAT SYSTEM IN HOT GAS REHEAT MODE										
Temp (F) Air Entering Condenser (Edb)		AIR ENTERING EVAPORATOR (F)								
		75 Dry Bulb			75 Dry Bulb			75 Dry Bulb		
		62.5 Wet Bulb			64 Wet Bulb			65.3 Wet Bulb		
		(50% Relative)			(56% Relative)			(60% Relative)		
		Air Entering Evaporator - Cfm								
		2550	3400	4250	2550	3400	4250	2550	3400	4250
80	TC	27.53	29.56	30.72	28.95	31.03	32.22	30.26	32.33	33.58
	SHC	-3.84	3.82	11.92	-9.25	-2.92	4.09	-13.93	-8.77	-2.82
	kW	5.09	5.11	5.13	5.11	5.14	5.15	5.14	5.15	5.17
75	TC	29.09	31.60	32.81	30.77	33.10	34.33	32.30	34.45	35.73
	SHC	-2.34	5.72	13.84	-7.51	-0.98	6.04	-11.95	-6.78	-0.82
	kW	4.97	4.91	4.93	4.95	4.94	4.95	4.94	4.96	4.97
70	TC	29.58	32.45	33.63	31.48	34.12	35.55	33.12	35.65	37.38
	SHC	-1.88	6.54	14.63	-6.83	0.00	7.20	-11.16	-5.63	0.75
	kW	4.99	4.90	4.92	4.96	4.90	4.89	4.93	4.90	4.86
60	TC	30.71	33.44	34.52	32.90	34.79	35.86	34.07	36.02	37.09
	SHC	-0.78	7.52	15.54	-5.47	0.68	7.57	-10.28	-5.24	0.55
	kW	5.03	4.95	5.00	4.94	5.01	5.05	4.99	5.06	5.09
50	TC	32.63	34.31	35.26	33.81	35.53	36.51	34.90	36.66	37.65
	SHC	1.05	8.38	16.29	-4.60	1.42	8.24	-9.49	-4.59	1.14
	kW	4.92	5.01	5.06	4.99	5.07	5.13	5.05	5.14	5.19
40	TC	31.94	33.26	35.77	32.96	35.70	37.86	35.17	38.01	38.92
	SHC	0.45	7.47	13.75	-5.35	1.63	9.52	-9.20	-3.29	2.36
	kW	5.16	5.27	5.20	5.25	5.19	5.10	5.16	5.11	5.17

**LEGEND**

- Edb - Entering Dry-Bulb
- Ewb - Entering Wet-Bulb
- kW - Compressor Motor Power Input
- ldb - Leaving Dry-Bulb
- lwb - Leaving Wet-Bulb
- SHC - Sensible Heat Capacity (1000 Btuh) Gross
- TC - Total Capacity (1000 Btuh) Gross

**NOTES:**

1. Direct interpolation is permissible. Do not extrapolate.
2. The following formulas may be used:

$$t_{ldb} = t_{edb} - \frac{\text{sensible capacity (Btuh)}}{1.10 \times \text{cfm}}$$

$t_{lwb}$  = Wet-bulb temperature corresponding to enthalpy of air leaving evaporator coil ( $h_{lwb}$ )

$$h_{lwb} = h_{ewb} - \frac{\text{total capacity (Btuh)}}{4.5 \times \text{cfm}}$$

Where:  $h_{ewb}$  = Enthalpy of air entering evaporator coil

**Table 26 – COOLING CAPACITIES**

**2-STAGE COOLING**

**10 TONS (12.0 EER)**

RGH110			AMBIENT TEMPERATURE (F)																	
			85			95			105			115			125					
			EAT (db)			EAT (db)			EAT (db)			EAT (db)			EAT (db)					
			75	80	85	75	80	85	75	80	85	75	80	85	75	80	85			
3000 Cfm	EAT (wb)	58	TC	105.6	105.6	118.0	101.7	101.7	114.1	97.5	97.5	109.9	92.9	92.9	105.2	87.8	87.8	100.2		
			SHC	93.3	105.6	118.0	89.4	101.7	114.1	85.1	97.5	109.9	80.5	92.9	105.2	75.4	87.8	100.2		
		62	TC	110.6	110.6	110.6	105.5	105.5	108.0	100.1	100.1	105.5	94.4	94.4	102.7	88.5	88.5	98.5		
			SHC	85.6	98.0	110.3	83.3	95.7	108.0	80.7	93.1	105.5	77.9	90.3	102.7	73.8	86.1	98.5		
		67	TC	120.5	120.5	120.5	115.0	115.0	115.0	109.0	109.0	109.0	102.7	102.7	102.7	95.7	95.7	95.7		
			SHC	70.0	82.3	94.7	67.7	80.1	92.5	65.4	77.8	90.1	63.1	75.5	87.9	60.0	72.4	84.8		
		72	TC	131.4	131.4	131.4	125.4	125.4	125.4	118.8	118.8	118.8	111.7	111.7	111.7	104.2	104.2	104.2		
			SHC	53.9	66.3	78.7	51.8	64.2	76.6	49.5	61.9	74.3	47.0	59.4	71.7	44.3	56.7	69.1		
		76	TC	-	140.8	140.8	-	134.2	134.2	-	127.0	127.0	-	119.4	119.4	-	111.5	111.5		
			SHC	-	52.5	64.9	-	50.8	63.2	-	48.7	61.1	-	46.4	58.7	-	44.0	56.4		
		3500 Cfm	EAT (wb)	58	TC	110.9	110.9	125.3	106.7	106.7	121.1	102.1	102.1	116.5	97.0	97.0	111.5	91.6	91.6	106.0
					SHC	96.4	110.9	125.3	92.2	106.7	121.1	87.6	102.1	116.5	82.6	97.0	111.5	77.1	91.6	106.0
				62	TC	113.6	113.6	120.7	108.4	108.4	118.1	103.1	103.1	114.5	97.9	97.9	109.5	92.0	92.0	105.3
					SHC	91.9	106.3	120.7	89.3	103.7	118.1	85.7	100.1	114.5	80.6	95.0	109.5	76.4	90.8	105.3
67	TC			123.5	123.5	123.5	117.8	117.8	117.8	111.5	111.5	111.5	104.7	104.7	104.7	97.6	97.6	97.6		
	SHC			74.2	88.6	103.1	72.2	86.6	101.0	69.8	84.3	98.7	67.0	81.4	95.9	64.3	78.8	93.2		
72	TC			134.6	134.6	134.6	128.2	128.2	128.2	121.3	121.3	121.3	113.9	113.9	113.9	106.1	106.1	106.1		
	SHC			55.9	70.3	84.8	53.7	68.1	82.6	51.4	65.8	80.2	48.8	63.2	77.7	46.1	60.6	75.0		
76	TC			-	144.0	144.0	-	137.1	137.1	-	129.7	129.7	-	121.8	121.8	-	113.5	113.5		
	SHC			-	55.3	69.7	-	53.1	67.6	-	50.9	65.4	-	48.6	63.0	-	46.0	60.5		
4000 Cfm	EAT (wb)			58	TC	115.3	115.3	131.8	110.7	110.7	127.2	105.8	105.8	122.3	100.4	100.4	116.9	94.6	94.6	111.1
					SHC	98.8	115.3	131.8	94.2	110.7	127.2	89.3	105.8	122.3	83.9	100.4	116.9	78.1	94.6	111.1
				62	TC	116.5	116.5	129.1	112.0	112.0	124.0	106.5	106.5	120.9	100.9	100.9	116.1	94.7	94.7	111.2
					SHC	96.1	112.6	129.1	91.0	107.5	124.0	87.9	104.4	120.9	83.1	99.6	116.1	78.2	94.7	111.2
		67	TC	125.9	125.9	125.9	119.8	119.8	119.8	113.3	113.3	113.3	106.4	106.4	106.4	99.1	99.1	101.1		
			SHC	78.2	94.7	111.2	76.0	92.5	109.0	73.5	90.0	106.5	70.9	87.4	103.9	68.1	84.6	101.1		
		72	TC	137.0	137.0	137.0	130.3	130.3	130.3	123.2	123.2	123.2	115.6	115.6	115.6	107.5	107.5	107.5		
			SHC	57.7	74.2	90.7	55.4	71.9	88.4	53.0	69.5	86.0	50.6	67.1	83.6	47.7	64.2	80.7		
		76	TC	-	146.5	146.5	-	139.3	139.3	-	131.6	131.6	-	123.5	123.5	-	115.0	115.0		
			SHC	-	57.4	73.9	-	55.3	71.8	-	53.0	69.5	-	50.6	67.1	-	48.0	64.5		
		4500 Cfm	EAT (wb)	58	TC	118.9	118.9	137.5	114.1	114.1	132.7	108.9	108.9	127.5	103.3	103.3	121.8	97.2	97.2	115.8
					SHC	100.3	118.9	137.5	95.5	114.1	132.7	90.3	108.9	127.5	84.7	103.3	121.8	78.6	97.2	115.8
				62	TC	119.9	119.9	135.3	115.0	115.0	130.8	109.2	109.2	126.7	103.3	103.3	121.9	97.2	97.2	115.8
					SHC	98.2	116.8	135.3	93.7	112.3	130.8	89.6	108.2	126.7	84.8	103.3	121.9	78.7	97.2	115.8
67	TC			127.7	127.7	127.7	121.4	121.4	121.4	114.8	114.8	114.8	107.7	107.7	111.5	100.1	100.1	108.5		
	SHC			82.1	100.7	119.3	79.8	98.3	116.9	77.2	95.8	114.4	74.4	92.9	111.5	71.4	89.9	108.5		
72	TC			138.9	138.9	138.9	132.1	132.1	132.1	124.7	124.7	124.7	116.9	116.9	116.9	108.6	108.6	108.6		
	SHC			59.3	77.9	96.5	57.2	75.7	94.3	54.8	73.3	91.9	52.1	70.6	89.2	49.3	67.9	86.5		
76	TC			-	148.4	148.4	-	141.1	141.1	-	133.2	133.2	-	124.9	124.9	-	116.1	116.1		
	SHC			-	59.4	78.0	-	57.2	75.8	-	54.9	73.5	-	52.5	71.0	-	49.9	68.4		
5000 Cfm	EAT (wb)			58	TC	122.0	122.0	142.6	117.0	117.0	137.6	111.6	111.6	132.2	105.7	105.7	126.3	99.3	99.3	119.9
					SHC	101.4	122.0	142.6	96.4	117.0	137.6	90.9	111.6	132.2	85.0	105.7	126.3	78.7	99.3	119.9
				62	TC	122.7	122.7	141.4	117.1	117.1	137.7	111.6	111.6	132.2	105.7	105.7	126.3	99.4	99.4	120.0
					SHC	100.2	120.8	141.4	96.4	117.1	137.7	91.0	111.6	132.2	85.1	105.7	126.3	78.8	99.4	120.0
		67	TC	129.2	129.2	129.2	122.8	122.8	124.6	115.9	115.9	121.9	108.7	108.7	119.0	101.1	101.1	115.7		
			SHC	85.7	106.4	127.0	83.3	104.0	124.6	80.7	101.3	121.9	77.8	98.4	119.0	74.4	95.1	115.7		
		72	TC	140.5	140.5	140.5	133.4	133.4	133.4	125.9	125.9	125.9	118.0	118.0	118.0	109.6	109.6	109.6		
			SHC	61.0	81.6	102.3	58.7	79.3	99.9	56.3	76.9	97.5	53.7	74.3	94.9	50.9	71.5	92.1		
		76	TC	-	150.1	150.1	-	142.6	142.6	-	134.5	134.5	-	126.0	126.0	-	117.1	117.1		
			SHC	-	61.4	82.0	-	59.2	79.8	-	56.8	77.4	-	54.3	74.9	-	51.7	72.3		

**LEGEND:**

- Do not operate
- Cfm - Cubic feet per minute (supply air)
- EAT(db) - Entering air temperature (dry bulb)
- EAT(wb) - Entering air temperature (wet bulb)
- SHC - Sensible heat capacity (1000 Btuh) Gross
- TC - Total capacity (1000 Btuh) Gross

**NOTE:** See Minimum-Maximum Airflow Ratings in Table 7. Do not operate outside these limits.

**Table 27 – COOLING CAPACITIES**

**2-STAGE COOLING**

**10 TONS (12.0 EER) (cont)**

RGH110 (10 TONS) - UNIT WITH HOT GAS RE-HEAT SYSTEM IN SUBCOOLING MODE										
Temp (F) Air Entering Condenser (Edb)		AIR ENTERING EVAPORATOR - CFM								
		3000			4000			5000		
		Air Entering Evaporator - Ewb (F)								
		72	67	62	72	67	62	72	67	62
75	TC	121.34	110.46	99.60	139.20	125.18	111.17	157.20	140.10	110.50
	SHC	58.86	72.03	85.20	67.31	80.25	93.18	74.00	86.80	72.00
	kW	6.61	6.54	6.45	6.65	6.58	6.50	6.67	6.62	6.53
85	TC	115.30	105.01	94.73	128.03	114.90	101.77	140.90	124.90	105.00
	SHC	45.81	62.19	78.57	55.02	71.16	87.29	62.30	78.30	62.20
	kW	6.76	6.88	6.78	6.80	6.73	6.83	6.82	6.77	6.87
95	TC	109.26	99.57	89.89	116.87	104.62	92.38	124.60	109.70	99.60
	SHC	32.76	52.35	71.93	42.70	62.07	81.40	50.60	69.80	52.30
	kW	7.55	7.49	7.39	7.58	7.51	7.45	7.60	7.56	7.49
105	TC	103.21	94.13	85.04	105.71	94.34	82.98	108.20	94.60	94.10
	SHC	19.71	42.51	65.30	30.45	52.98	75.51	39.00	61.30	42.50
	kW	8.47	8.42	8.32	8.51	8.44	8.37	8.53	8.49	8.41
115	TC	97.17	88.68	80.20	94.54	84.06	73.58	91.90	79.40	88.70
	SHC	6.67	32.66	58.66	18.16	43.89	69.62	27.30	52.80	32.60
	kW	9.42	9.37	9.27	9.46	9.39	9.32	9.48	9.44	9.36
125	TC	91.12	83.24	75.36	83.38	73.78	64.19	75.60	64.20	83.20
	SHC	-6.40	22.82	52.03	5.87	34.80	63.73	15.60	44.30	22.80
	kW	10.35	10.30	10.20	10.39	10.32	10.25	10.41	10.37	10.29

RGH110 (10 TONS) - UNIT WITH HOT GAS RE-HEAT SYSTEM IN HOT GAS REHEAT MODE										
Temp (F) Air Entering Condenser (Edb)		AIR ENTERING EVAPORATOR (F)								
		75 Dry Bulb			75 Dry Bulb			75 Dry Bulb		
		62.5 Wet Bulb			64 Wet Bulb			65.3 Wet Bulb		
		(50% Relative)			(56% Relative)			(60% Relative)		
		Air Entering Evaporator - Cfm								
3000	4000	5000	3000	4000	5000	3000	4000	5000		
75	TC	46.00	49.70	52.50	50.20	52.60	55.00	51.40	55.60	57.90
	SHC	8.50	18.40	26.50	3.60	11.90	18.50	-1.10	5.20	11.70
	kW	6.56	6.50	6.42	6.55	6.48	6.40	6.53	6.49	6.40
85	TC	47.80	51.30	54.10	51.70	54.20	56.80	53.30	57.50	59.70
	SHC	10.20	20.00	28.20	5.30	13.40	20.10	0.50	6.80	13.20
	kW	6.51	6.45	6.36	6.50	6.44	6.35	6.47	6.44	6.35
95	TC	50.00	53.60	56.20	54.00	56.30	58.80	55.30	59.60	61.80
	SHC	12.00	21.60	29.80	6.90	15.00	21.70	2.20	8.50	14.70
	kW	6.45	6.40	6.29	6.45	6.39	6.28	6.42	6.39	6.28
105	TC	54.00	57.50	60.10	57.90	60.20	62.70	59.30	63.50	65.70
	SHC	15.20	24.70	31.90	10.20	18.30	24.90	5.40	11.80	18.00
	kW	6.33	6.28	6.19	6.33	6.27	6.17	6.30	6.27	6.17
115	TC	58.00	61.40	64.20	61.80	64.40	66.50	63.30	67.20	69.50
	SHC	18.50	28.00	36.20	13.50	21.50	28.20	8.70	15.10	21.30
	kW	6.22	6.17	6.10	6.22	6.16	6.08	6.19	6.16	6.08
125	TC	61.90	65.30	68.00	65.70	68.10	70.50	67.20	71.30	73.50
	SHC	21.70	31.10	39.30	16.70	24.90	31.20	12.00	18.30	24.60
	kW	6.10	6.05	5.98	6.10	6.04	5.96	6.07	6.04	5.96

**LEGEND**

- Edb - Entering Dry-Bulb
- Ewb - Entering Wet-Bulb
- kW - Compressor Motor Power Input
- ldb - Leaving Dry-Bulb
- lwb - Leaving Wet-Bulb
- SHC - Sensible Heat Capacity (1000 Btuh) Gross
- TC - Total Capacity (1000 Btuh) Gross

**NOTES:**

1. Direct interpolation is permissible. Do not extrapolate.
2. The following formulas may be used:

$$t_{ldb} = t_{edb} - \frac{\text{sensible capacity (Btuh)}}{1.10 \times \text{cfm}}$$

$t_{lwb}$  = Wet-bulb temperature corresponding to enthalpy of air leaving evaporator coil ( $h_{lwb}$ )

$$h_{lwb} = h_{ewb} - \frac{\text{total capacity (Btuh)}}{4.5 \times \text{cfm}}$$

Where:  $h_{ewb}$  = Enthalpy of air entering evaporator coil

**Table 28 – COOLING CAPACITIES**

**2-STAGE COOLING**

**10 TONS (11.5 EER)**

RGH120			AMBIENT TEMPERATURE (F)																
			85			95			105			115			125				
			EAT (db)			EAT (db)			EAT (db)			EAT (db)			EAT (db)				
			75	80	85	75	80	85	75	80	85	75	80	85	75	80	85		
3000 Cfm	EAT (wb)	58	TC	104.3	104.3	118.5	99.5	99.5	113	93.4	93.4	106.1	86.7	86.7	98.6	79.7	79.7	90.6	
			SHC	90.2	104.3	118.5	86	99.5	113	80.6	93.4	106.1	74.9	86.7	98.6	68.8	79.7	90.6	
		62	TC	109.7	109.7	112.4	103.6	103.6	109.5	95.9	95.9	105.9	87.6	87.6	101.2	79.8	79.8	94.4	
			SHC	80.8	96.6	112.4	78	93.8	109.5	74.5	90.2	105.9	70.3	85.7	101.2	65.2	79.8	94.4	
		67	TC	121.5	121.5	121.5	115.4	115.4	115.4	107.8	107.8	107.8	98.7	98.7	98.7	89.1	89.1	89.1	
			SHC	65.2	81	96.9	62.7	78.6	94.5	59.7	75.6	91.5	56.2	72	87.9	52.5	68.3	84.2	
	72	TC	133	133	133	127.1	127.1	127.1	120.5	120.5	120.5	112	112	112	102.1	102.1	102.1		
		SHC	48.7	64.5	80.4	46.5	62.4	78.3	44.1	60	75.9	41.2	57.1	73	37.8	53.7	69.6		
	76	TC	-	140.9	140.9	-	135.1	135.1	-	128.4	128.4	-	121.3	121.3	-	112.5	112.5		
		SHC	-	50.6	67.1	-	48.7	65.2	-	46.6	63.1	-	44.3	60.7	-	41.4	57.7		
	3500 Cfm	EAT (wb)	58	TC	109.9	109.9	124.9	104.9	104.9	119.3	98.7	98.7	112.2	91.6	91.6	104.2	84.2	84.2	95.8
				SHC	94.9	109.9	124.9	90.6	104.9	119.3	85.2	98.7	112.2	79	91.6	104.2	72.6	84.2	95.8
62			TC	112.8	112.8	123.1	106.7	106.7	120	99.5	99.5	115.3	91.7	91.7	108.5	84.3	84.3	99.8	
			SHC	86.8	104.9	123.1	83.9	102	120	80	97.6	115.3	74.9	91.7	108.5	68.8	84.3	99.8	
67			TC	124.2	124.2	124.2	118	118	118	110.3	110.3	110.3	101	101	101	91	91	92.5	
			SHC	68.4	86.7	104.9	66.1	84.3	102.6	63.2	81.5	99.8	59.6	78	96.3	55.9	74.2	92.5	
72		TC	135.2	135.2	135.2	129.1	129.1	129.1	122.4	122.4	122.4	114.2	114.2	114.2	104.2	104.2	104.2		
		SHC	49.2	67.3	85.4	47.1	65.3	83.4	44.8	63	81.2	42	60.4	78.7	38.7	57.1	75.5		
76		TC	-	142.4	142.4	-	136.5	136.5	-	129.6	129.6	-	122.4	122.4	-	114	114		
		SHC	-	51.7	70.9	-	49.7	68.7	-	47.5	66.3	-	45.2	63.8	-	42.6	61.2		
4000 Cfm		EAT (wb)	58	TC	114.3	114.3	130	109.2	109.2	124.2	102.9	102.9	117	95.4	95.4	108.7	87.7	87.7	99.9
				SHC	98.6	114.3	130	94.2	109.2	124.2	88.7	102.9	117	82.2	95.4	108.7	75.5	87.7	99.9
	62		TC	115.3	115.3	132.4	109.6	109.6	128.3	102.9	102.9	121.9	95.5	95.5	113.2	87.8	87.8	104.1	
			SHC	91.9	112.2	132.4	88.7	108.5	128.3	84	102.9	121.9	77.9	95.5	113.2	71.5	87.8	104.1	
	67		TC	125.8	125.8	125.8	119.5	119.5	119.5	111.9	111.9	111.9	102.4	102.4	104.2	92.2	92.2	100.4	
			SHC	71.3	91.8	112.3	69	89.6	110.2	66.2	86.9	107.6	62.8	83.5	104.2	59.1	79.7	100.4	
	72	TC	136.3	136.3	136.3	130.2	130.2	130.2	123.4	123.4	123.4	115.4	115.4	115.4	105.3	105.3	105.3		
		SHC	49.5	69.7	89.8	47.4	67.7	87.9	45.1	65.5	85.9	42.5	63.1	83.7	39.3	60.1	80.9		
	76	TC	-	143.1	143.1	-	137.1	137.1	-	130.1	130.1	-	122.6	122.6	-	114.5	114.5		
		SHC	-	52.2	73.2	-	50.2	71.1	-	48	68.7	-	45.7	66.4	-	43.3	64.1		
	4500 Cfm	EAT (wb)	58	TC	117.5	117.5	133.8	112.4	112.4	127.9	106	106	120.7	98.4	98.4	112.1	90.3	90.3	103
				SHC	101.3	117.5	133.8	96.8	112.4	127.9	91.2	106	120.7	84.6	98.4	112.1	77.7	90.3	103
62			TC	117.6	117.6	139.4	112.5	112.5	133.3	106.1	106.1	125.8	98.5	98.5	116.8	90.4	90.4	107.4	
			SHC	95.9	117.6	139.4	91.6	112.5	133.3	86.4	106.1	125.8	80.1	98.5	116.8	73.5	90.4	107.4	
67			TC	126.6	126.6	126.6	120.2	120.2	120.2	112.8	112.8	114.8	103.2	103.2	111.6	93	93	107.6	
			SHC	73.7	96.4	119.2	71.5	94.3	117.2	68.9	91.8	114.8	65.6	88.6	111.6	61.8	84.7	107.6	
72		TC	136.7	136.7	136.7	130.5	130.5	130.5	123.6	123.6	123.6	115.7	115.7	115.7	105.7	105.7	105.7		
		SHC	49.4	71.6	93.7	47.4	69.7	91.9	45.1	67.5	89.9	42.7	65.4	88.2	39.5	62.6	85.8		
76		TC	-	143.1	143.1	-	137	137	-	129.9	129.9	-	122.4	122.4	-	114.3	114.3		
		SHC	-	52.4	75.1	-	50.5	73.1	-	48.2	70.8	-	46	68.5	-	43.7	66.5		
5000 Cfm		EAT (wb)	58	TC	119.9	119.9	136.7	114.7	114.7	130.7	108.4	108.4	123.6	100.6	100.6	114.8	92.3	92.3	105.4
				SHC	103.2	119.9	136.7	98.6	114.7	130.7	93.2	108.4	123.6	86.4	100.6	114.8	79.2	92.3	105.4
	62		TC	120	120	142.4	114.7	114.7	136.2	108.5	108.5	128.8	100.7	100.7	119.7	92.4	92.4	109.9	
			SHC	97.6	120	142.4	93.3	114.7	136.2	88.1	108.5	128.8	81.7	100.7	119.7	74.9	92.4	109.9	
	67		TC	126.8	126.8	126.8	120.4	120.4	123.6	113.2	113.2	121.3	103.8	103.8	118.4	93.6	93.6	114	
			SHC	75.7	100.6	125.4	73.6	98.6	123.6	71.2	96.2	121.3	68	93.2	118.4	64.2	89.1	114	
	72	TC	136.5	136.5	136.5	130.2	130.2	130.2	123.2	123.2	123.2	115.5	115.5	115.5	105.6	105.6	105.6		
		SHC	49.1	73.1	97	47.1	71.3	95.4	44.9	69.2	93.5	42.5	67.3	92	39.5	64.9	90.2		
	76	TC	-	142.7	142.7	-	136.5	136.5	-	129.4	129.4	-	121.6	121.6	-	113.6	113.6		
		SHC	-	52.2	76.7	-	50.4	74.7	-	48.2	72.4	-	45.9	70.1	-	43.7	68.3		

**LEGEND:**

- Do not operate
- Cfm - Cubic feet per minute (supply air)
- EAT(db) - Entering air temperature (dry bulb)
- EAT(wb) - Entering air temperature (wet bulb)
- SHC - Sensible heat capacity (1000 Btuh) Gross
- TC - Total capacity (1000 Btuh) Gross

**NOTE:** See Minimum-Maximum Airflow Ratings in Table 7. Do not operate outside these limits.

**Table 29 – COOLING CAPACITIES**

**2-STAGE COOLING**

**10 TONS (11.5 EER) (cont)**

RGH120 (10 TONS) - UNIT WITH HOT GAS RE-HEAT SYSTEM IN SUBCOOLING MODE										
Temp (F) Air Entering Condenser (Edb)		AIR ENTERING EVAPORATOR - CFM								
		3000			4000			5000		
		Air Entering Evaporator - Ewb (F)								
		72	67	62	72	67	62	72	67	62
75	TC	135.8	123.1	111.6	144.0	130.9	119.2	148.7	135.7	122.9
	SHC	56.7	72.8	88.9	66.1	86.9	107.4	74.4	100.1	121.0
	kW	6.42	6.26	6.13	6.54	6.37	6.22	6.61	6.43	6.26
85	TC	127.3	115.4	104.5	134.9	120.1	111.7	139.3	126.9	116.8
	SHC	48.6	65.4	82.1	57.5	76.6	100.2	65.4	91.8	115.0
	kW	7.20	7.04	6.90	7.31	7.11	7.00	7.38	7.21	7.07
95	TC	118.1	106.5	96.9	125.2	113.6	103.6	129.5	117.8	108.4
	SHC	39.9	57.0	74.9	48.3	70.5	92.4	56.2	83.1	106.8
	kW	8.06	7.89	7.76	8.17	8.00	7.86	8.24	8.07	7.93
105	TC	107.3	97.8	87.8	114.5	103.8	94.5	117.6	107.3	99.0
	SHC	29.6	48.7	66.2	38.1	61.3	83.8	44.9	73.1	97.5
	kW	8.99	8.85	8.72	9.11	8.95	8.82	9.16	9.01	8.88
115	TC	95.7	86.3	78.2	102.1	91.3	83.4	105.7	95.8	88.2
	SHC	18.6	37.8	57.1	26.4	49.4	73.2	33.6	62.3	87.0
	kW	10.03	9.89	9.79	10.14	9.97	9.86	10.20	10.05	9.94
125	TC	83.7	75.2	67.7	87.5	80.1	72.5	92.1	83.1	75.2
	SHC	7.3	27.4	47.2	12.5	38.8	62.9	20.6	50.3	74.2
	kW	11.17	11.06	10.98	11.23	11.13	11.03	11.30	11.17	11.07

RGH120 (10 TONS) - UNIT WITH HOT GAS RE-HEAT SYSTEM IN HOT GAS REHEAT MODE										
Temp (F) Air Entering Condenser (Edb)		AIR ENTERING EVAPORATOR (F)								
		75 Dry Bulb			75 Dry Bulb			75 Dry Bulb		
		62.5 Wet Bulb			64 Wet Bulb			65.3 Wet Bulb		
		(50% Relative)			(56% Relative)			(60% Relative)		
		Air Entering Evaporator - Cfm								
		3000	4000	5000	3000	4000	5000	3000	4000	5000
80	TC	45.83	49.08	50.90	47.62	50.84	52.72	49.16	52.45	54.33
	SHC	4.82	14.45	24.36	-1.60	6.39	14.99	-7.27	-0.59	6.73
	kW	7.33	7.46	7.55	7.40	7.53	7.62	7.46	7.60	7.68
75	TC	48.52	51.89	53.81	50.31	53.74	55.73	51.92	55.47	57.43
	SHC	7.37	17.08	27.08	0.95	9.11	17.81	-4.65	2.25	9.63
	kW	6.93	7.07	7.15	7.00	7.14	7.23	7.06	7.21	7.29
70	TC	51.15	54.66	56.69	52.96	56.60	58.66	54.65	58.34	60.43
	SHC	9.87	19.70	29.80	3.47	11.82	20.57	-2.05	4.98	12.45
	kW	6.56	6.69	6.78	6.62	6.76	6.85	6.68	6.83	6.91
60	TC	52.89	56.41	59.04	55.63	59.10	62.68	58.00	62.31	64.50
	SHC	11.58	21.44	32.07	6.06	14.26	24.41	1.21	8.78	16.36
	kW	6.60	6.80	6.72	6.53	6.71	6.51	6.46	6.48	6.58
50	TC	55.13	59.53	62.75	58.04	62.61	64.69	59.64	64.34	66.41
	SHC	13.77	24.43	35.63	8.41	17.62	26.38	2.80	10.77	18.23
	kW	6.57	6.53	6.44	6.43	6.41	6.54	6.52	6.50	6.64
40	TC	57.08	60.11	64.35	58.75	63.63	65.58	60.16	65.23	69.04
	SHC	15.67	25.05	33.55	9.13	18.64	27.28	3.34	11.67	20.76
	kW	6.51	6.77	6.62	6.64	6.54	6.70	6.75	6.65	6.50

**LEGEND**

- Edb - Entering Dry-Bulb
- Ewb - Entering Wet-Bulb
- kW - Compressor Motor Power Input
- ldb - Leaving Dry-Bulb
- lwb - Leaving Wet-Bulb
- SHC - Sensible Heat Capacity (1000 Btuh) Gross
- TC - Total Capacity (1000 Btuh) Gross

**NOTES:**

1. Direct interpolation is permissible. Do not extrapolate.
2. The following formulas may be used:

$$t_{ldb} = t_{edb} - \frac{\text{sensible capacity (Btuh)}}{1.10 \times \text{cfm}}$$

$t_{lwb}$  = Wet-bulb temperature corresponding to enthalpy of air leaving evaporator coil ( $h_{lwb}$ )

$$h_{lwb} = h_{ewb} - \frac{\text{total capacity (Btuh)}}{4.5 \times \text{cfm}}$$

Where:  $h_{ewb}$  = Enthalpy of air entering evaporator coil

**Table 30 – COOLING CAPACITIES**

**2-STAGE COOLING**

**12.5 TONS**

RGH150			AMBIENT TEMPERATURE (F)																
			85			95			105			115			125				
			EAT (db)			EAT (db)			EAT (db)			EAT (db)			EAT (db)				
			75	80	85	75	80	85	75	80	85	75	80	85	75	80	85		
3750 Cfm	EAT (wb)	58	TC	131.9	131.9	149.8	127.0	127.0	144.1	121.5	121.5	137.9	115.4	115.4	131.0	108.7	108.7	123.4	
			SHC	114.1	131.9	149.8	109.8	127.0	144.1	105.0	121.5	137.9	99.8	115.4	131.0	94.0	108.7	123.4	
		62	TC	138.0	138.0	143.4	131.7	131.7	140.4	124.7	124.7	136.9	117.1	117.1	133.1	109.4	109.4	127.4	
			SHC	103.4	123.4	143.4	100.4	120.4	140.4	97.1	117.0	136.9	93.4	113.2	133.1	88.8	108.1	127.4	
		67	TC	151.5	151.5	151.5	144.5	144.5	144.5	136.9	136.9	136.9	128.5	128.5	128.5	119.4	119.4	119.4	
			SHC	85.1	105.2	125.3	82.1	102.2	122.3	78.9	99.0	119.0	75.4	95.5	115.5	71.7	91.8	111.8	
	72	TC	166.1	166.1	166.1	158.5	158.5	158.5	150.2	150.2	150.2	141.1	141.1	141.1	131.3	131.3	131.3		
		SHC	66.2	86.5	106.7	63.3	83.6	103.8	60.2	80.4	100.6	56.8	76.9	97.1	53.1	73.3	93.4		
	76	TC	-	178.6	178.6	-	170.5	170.5	-	161.6	161.6	-	151.8	151.8	-	141.3	141.3		
		SHC	-	71.1	91.8	-	68.3	88.9	-	65.2	85.8	-	61.8	82.5	-	58.2	78.7		
	4375 Cfm	EAT (wb)	58	TC	139.2	139.2	158.0	133.8	133.8	151.9	127.9	127.9	145.2	121.3	121.3	137.7	114.1	114.1	129.5
				SHC	120.4	139.2	158.0	115.7	133.8	151.9	110.6	127.9	145.2	104.9	121.3	137.7	98.7	114.1	129.5
62			TC	142.4	142.4	157.6	135.8	135.8	154.1	128.9	128.9	149.2	121.7	121.7	142.9	114.2	114.2	134.8	
			SHC	111.5	134.5	157.6	108.2	131.2	154.1	104.2	126.7	149.2	99.4	121.1	142.9	93.6	114.2	134.8	
67			TC	155.8	155.8	155.8	148.5	148.5	148.5	140.4	140.4	140.4	131.6	131.6	131.6	122.1	122.1	123.0	
			SHC	90.3	113.6	136.8	87.3	110.5	133.8	84.0	107.2	130.5	80.4	103.6	126.8	76.6	99.8	123.0	
72		TC	170.6	170.6	170.6	162.7	162.7	162.7	154.0	154.0	154.0	144.4	144.4	144.4	134.1	134.1	134.1		
		SHC	68.5	91.9	115.3	65.5	88.9	112.3	62.3	85.6	109.0	58.8	82.1	105.4	55.1	78.4	101.7		
76		TC	-	183.3	183.3	-	174.8	174.8	-	165.4	165.4	-	155.2	155.2	-	144.3	144.3		
		SHC	-	74.3	98.3	-	71.3	95.2	-	68.0	91.9	-	64.6	88.3	-	60.9	84.5		
5000 Cfm		EAT (wb)	58	TC	145.3	145.3	164.9	139.5	139.5	158.4	133.2	133.2	151.2	126.2	126.2	143.2	118.5	118.5	134.5
				SHC	125.6	145.3	164.9	120.7	139.5	158.4	115.2	133.2	151.2	109.1	126.2	143.2	102.5	118.5	134.5
	62		TC	146.5	146.5	169.3	140.2	140.2	163.9	133.3	133.3	157.4	126.3	126.3	149.1	118.6	118.6	140.0	
			SHC	118.3	143.8	169.3	114.1	139.0	163.9	109.3	133.3	157.4	103.5	126.3	149.1	97.2	118.6	140.0	
	67		TC	159.1	159.1	159.1	151.5	151.5	151.5	143.1	143.1	143.1	134.0	134.0	137.7	124.2	124.2	133.7	
			SHC	95.2	121.6	148.0	92.2	118.5	144.9	88.8	115.1	141.5	85.1	111.4	137.7	81.3	107.5	133.7	
	72	TC	174.1	174.1	174.1	165.9	165.9	165.9	156.8	156.8	156.8	146.9	146.9	146.9	136.2	136.2	136.2		
		SHC	70.5	97.0	123.5	67.5	94.0	120.5	64.2	90.7	117.1	60.6	87.1	113.5	56.9	83.3	109.6		
	76	TC	-	187.0	187.0	-	178.1	178.1	-	168.3	168.3	-	157.7	157.7	-	146.4	146.4		
		SHC	-	77.0	104.0	-	74.0	100.9	-	70.7	97.5	-	67.2	93.9	-	63.4	90.0		
	5625 Cfm	EAT (wb)	58	TC	150.4	150.4	170.8	144.4	144.4	163.9	137.7	137.7	156.3	130.3	130.3	147.9	122.2	122.2	138.7
				SHC	130.1	150.4	170.8	124.9	144.4	163.9	119.0	137.7	156.3	112.7	130.3	147.9	105.7	122.2	138.7
62			TC	150.7	150.7	177.9	144.5	144.5	170.6	137.8	137.8	162.7	130.4	130.4	153.9	122.3	122.3	144.4	
			SHC	123.5	150.7	177.9	118.4	144.5	170.6	112.9	137.8	162.7	106.8	130.4	153.9	100.2	122.3	144.4	
67			TC	161.7	161.7	161.7	153.9	153.9	155.6	145.3	145.3	152.1	135.9	135.9	148.2	125.9	125.9	143.9	
			SHC	100.0	129.4	158.8	96.8	126.2	155.6	93.4	122.7	152.1	89.7	118.9	148.2	85.6	114.8	143.9	
72		TC	176.9	176.9	176.9	168.3	168.3	168.3	159.0	159.0	159.0	148.8	148.8	148.8	137.9	137.9	137.9		
		SHC	72.3	101.9	131.5	69.3	98.8	128.4	66.0	95.5	125.0	62.4	91.8	121.3	58.6	88.0	117.4		
76		TC	-	189.8	189.8	-	180.6	180.6	-	170.6	170.6	-	159.7	159.7	-	148.1	148.1		
		SHC	-	79.6	109.7	-	76.5	106.5	-	73.2	103.0	-	69.6	99.2	-	65.7	95.1		
6250 Cfm		EAT (wb)	58	TC	154.8	154.8	175.8	148.5	148.5	168.6	141.5	141.5	160.6	133.7	133.7	151.8	125.3	125.3	142.3
				SHC	133.9	154.8	175.8	128.4	148.5	168.6	122.3	141.5	160.6	115.6	133.7	151.8	108.4	125.3	142.3
	62		TC	155.0	155.0	183.0	148.6	148.6	175.5	141.6	141.6	167.2	133.9	133.9	158.0	125.4	125.4	148.1	
			SHC	127.0	155.0	183.0	121.8	148.6	175.5	116.0	141.6	167.2	109.7	133.9	158.0	102.8	125.4	148.1	
	67		TC	163.8	163.8	169.3	155.8	155.8	166.0	147.0	147.0	162.3	137.5	137.5	158.1	127.4	127.4	153.3	
			SHC	104.5	136.9	169.3	101.3	133.6	166.0	97.8	130.0	162.3	93.9	126.0	158.1	89.7	121.5	153.3	
	72	TC	179.1	179.1	179.1	170.3	170.3	170.3	160.8	160.8	160.8	150.3	150.3	150.3	139.2	139.2	139.2		
		SHC	74.1	106.7	139.3	71.0	103.6	136.1	67.7	100.2	132.7	64.1	96.5	128.9	60.2	92.6	124.9		
	76	TC	-	192.1	192.1	-	182.7	182.7	-	172.3	172.3	-	161.2	161.2	-	149.4	149.4		
		SHC	-	82.1	115.1	-	79.0	111.8	-	75.6	108.2	-	71.9	104.3	-	67.9	100.0		

**LEGEND:**

- Do not operate
- Cfm - Cubic feet per minute (supply air)
- EAT(db) - Entering air temperature (dry bulb)
- EAT(wb) - Entering air temperature (wet bulb)
- SHC - Sensible heat capacity (1000 Btuh) Gross
- TC - Total capacity (1000 Btuh) Gross

**NOTE:** See Minimum-Maximum Airflow Ratings in Table 7. Do not operate outside these limits.

**Table 31 – COOLING CAPACITIES**

**2-STAGE COOLING**

**12.5 TONS (cont)**

RGH150 (12.5 TONS) - UNIT WITH HOT GAS RE-HEAT SYSTEM IN SUBCOOLING MODE										
Temp (F) Air Entering Condenser (Edb)		AIR ENTERING EVAPORATOR - CFM								
		3750			5000			6250		
		Air Entering Evaporator - Ewb (F)								
		72	67	62	72	67	62	72	67	62
75	TC	162.0	147.4	132.8	185.6	167.2	148.8	209.5	187.2	164.9
	SHC	85.0	101.4	117.4	96.9	113.0	129.0	106.5	122.4	138.4
	kW	7.70	7.60	7.30	7.90	7.70	7.40	8.10	7.80	7.50
85	TC	154.8	140.9	127.0	171.7	154.4	137.1	188.8	168.0	147.2
	SHC	70.2	90.4	110.6	83.1	103.2	123.2	93.4	113.4	133.3
	kW	8.80	8.70	8.30	8.90	8.70	8.40	9.10	8.80	8.50
95	TC	147.5	134.4	121.2	157.8	141.6	125.4	168.1	148.8	129.6
	SHC	55.5	79.7	103.9	69.3	93.4	117.5	80.4	104.3	128.3
	kW	9.80	9.70	9.30	9.90	9.70	9.50	10.10	9.80	9.60
105	TC	140.3	127.8	115.4	143.8	128.7	113.7	147.4	129.7	111.9
	SHC	40.9	69.0	97.2	55.5	83.6	111.7	67.3	95.3	111.9
	kW	10.80	10.70	10.30	10.90	10.70	10.50	11.10	10.80	10.60
115	TC	133.0	121.3	109.5	129.9	115.9	101.9	126.7	110.5	94.2
	SHC	26.2	58.3	90.4	41.8	73.8	101.9	54.2	86.2	94.2
	kW	11.80	11.70	11.40	11.90	11.70	11.60	12.10	11.80	11.70
125	TC	125.8	114.7	103.7	115.9	103.1	90.2	106.0	91.3	76.6
	SHC	11.5	47.6	83.7	28.0	64.0	90.2	41.2	77.2	76.6
	kW	12.80	12.70	12.40	12.90	12.70	12.60	13.10	12.80	12.70

RGH150 (12.5 TONS) - UNIT WITH HOT GAS RE-HEAT SYSTEM IN HOT GAS REHEAT MODE										
Temp (F) Air Entering Condenser (Edb)		AIR ENTERING EVAPORATOR (F)								
		75 Dry Bulb			75 Dry Bulb			75 Dry Bulb		
		62.5 Wet Bulb			64 Wet Bulb			65.3 Wet Bulb		
		(50% Relative)			(56% Relative)			(60% Relative)		
		Air Entering Evaporator - Cfm								
		3750	5000	6250	3750	5000	6250	3750	5000	6250
80	TC	57.70	60.00	66.40	60.20	66.80	69.50	64.30	69.10	72.30
	SHC	21.30	27.00	44.00	12.80	22.40	32.50	8.60	16.20	25.50
	kW	8.08	8.15	8.23	8.28	8.34	8.37	8.36	8.43	8.52
75	TC	59.00	61.20	67.90	61.40	68.10	71.00	65.80	70.70	73.70
	SHC	22.40	28.10	44.80	13.50	23.50	33.70	9.30	17.10	26.30
	kW	8.06	8.13	8.21	8.25	8.31	8.34	8.33	8.40	8.49
70	TC	60.40	62.90	69.20	63.10	69.40	72.50	67.00	72.00	75.00
	SHC	23.20	28.90	46.00	14.50	24.30	34.40	10.30	17.90	27.40
	kW	8.04	8.11	8.18	8.23	8.29	8.32	8.31	8.38	8.47
60	TC	63.40	65.70	72.00	65.90	72.30	75.20	70.00	74.80	77.80
	SHC	24.80	30.50	47.80	16.10	25.90	36.00	11.90	19.60	29.00
	kW	8.00	8.07	8.15	8.20	8.25	8.29	8.28	8.35	8.44
50	TC	66.20	68.60	74.30	68.80	74.60	78.20	72.80	77.80	80.70
	SHC	26.60	32.30	49.40	17.70	27.70	37.80	13.50	21.20	30.60
	kW	7.94	8.01	8.08	8.13	8.20	8.23	8.22	8.29	8.38
40	TC	69.10	71.60	77.80	71.80	78.00	81.00	75.70	80.60	83.70
	SHC	28.20	33.90	50.10	19.40	29.30	39.80	15.20	22.90	32.20
	kW	7.90	7.97	8.04	8.09	8.15	8.17	8.16	8.23	8.32

**LEGEND**

- Edb - Entering Dry-Bulb
- Ewb - Entering Wet-Bulb
- kW - Compressor Motor Power Input
- ldb - Leaving Dry-Bulb
- lwb - Leaving Wet-Bulb
- SHC - Sensible Heat Capacity (1000 Btuh) Gross
- TC - Total Capacity (1000 Btuh) Gross

**NOTES:**

1. Direct interpolation is permissible. Do not extrapolate.
2. The following formulas may be used:

$$t_{ldb} = t_{edb} - \frac{\text{sensible capacity (Btuh)}}{1.10 \times \text{cfm}}$$

$t_{lwb}$  = Wet-bulb temperature corresponding to enthalpy of air leaving evaporator coil ( $h_{lwb}$ )

$$h_{lwb} = h_{ewb} - \frac{\text{total capacity (Btuh)}}{4.5 \times \text{cfm}}$$

Where:  $h_{ewb}$  = Enthalpy of air entering evaporator coil

**Table 32 – STATIC PRESSURE ADDERS (IN. WG) (FACTORY OPTIONS AND/OR ACCESSORIES)**

**Hot Gas Re-Heat**

3-6 Tons									
CFM (in. wg)	1000	1250	1500	1750	2000	2250	2500	2750	3000
3 Tons	0.04	0.052	0.07	-	-	-	-	-	-
4 Tons	-	0.106	0.138	0.172	0.21	-	-	-	-
5 Tons	-	-	0.138	0.172	0.21	0.252	0.30	-	-
6 Tons	-	-	-	0.112	0.125	0.161	0.19	0.22	0.25

7.5-12.5 Tons										
CFM (in. wg)	4000	4250	4500	4750	5000	5250	5500	5750	6000	6250
7.5 Tons	-	-	-	-	-	-	-	-	-	-
8.5 Tons	0.20	0.22	-	-	-	-	-	-	-	-
10 Tons	0.20	0.22	0.24	0.26	0.28	-	-	-	-	-
12.5 Tons	0.06	0.07	0.07	0.08	0.08	0.09	0.10	0.10	0.11	0.12

**ECONOMIZER, BAROMETRIC RELIEF AND P.E. PERFORMANCE**

**Vertical Application**

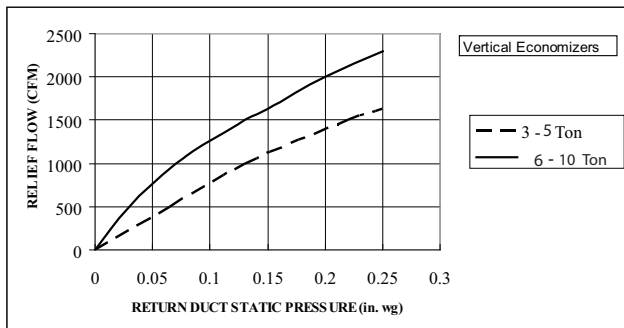

C10475

**Fig. 16 - Barometric Relief Flow-Vertical 3-10 Ton**

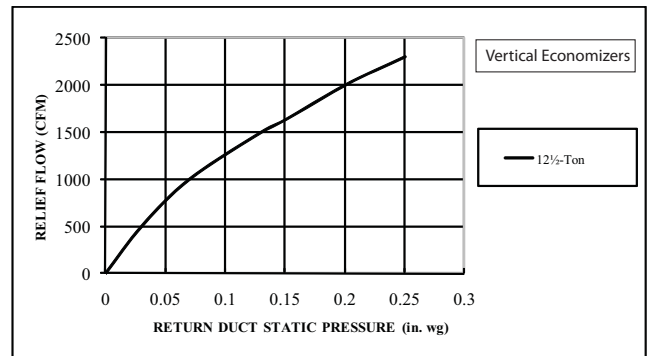

C101004

**Fig. 18 - Barometric Relief Flow-Vertical 12.5 Ton**

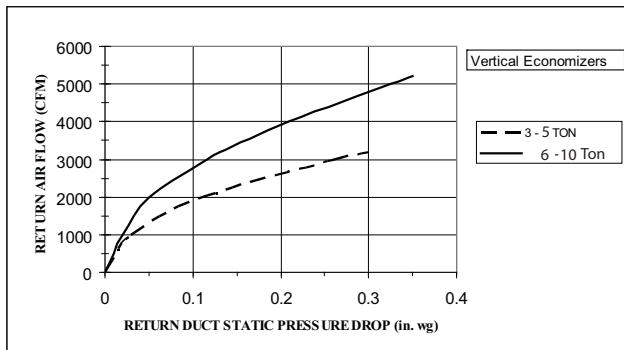

C10477

**Fig. 17 - Return Air Pressure Drop-Vertical 3-10 Ton**

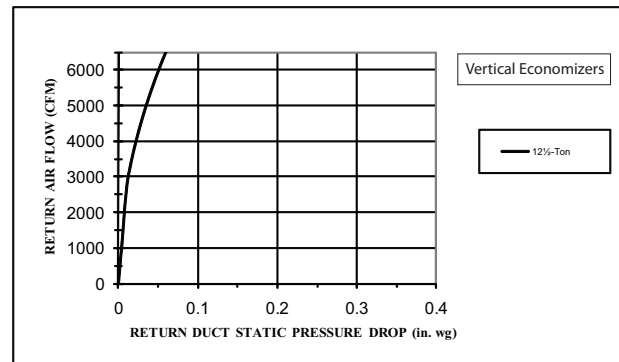

C101005

**Fig. 19 - Return Air Pressure Drop-Vertical 12.5 Ton**

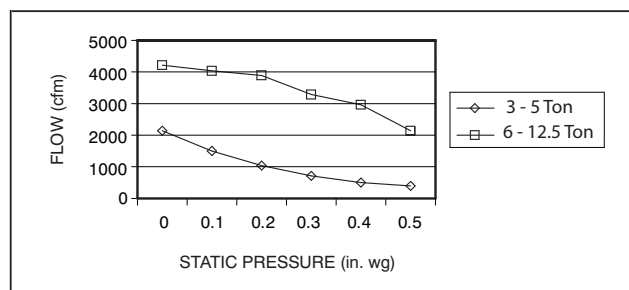

C10996

**Fig. 20 - Vertical Power Exhaust Performance**

# ECONOMIZER, BAROMETRIC RELIEF AND P.E. PERFORMANCE (cont)

## Horizontal Application

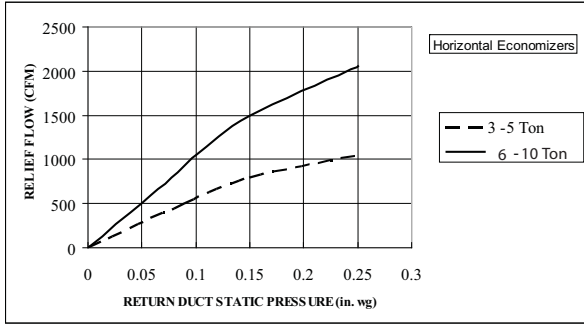

C10472

**Fig. 21 - Barometric Relief Flow-Horizontal 3-10 Ton**

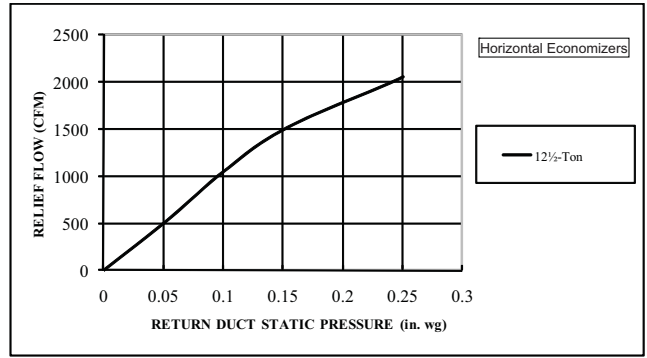

C101002

**Fig. 23 - Barometric Relief Flow-Horizontal 12.5 Ton**

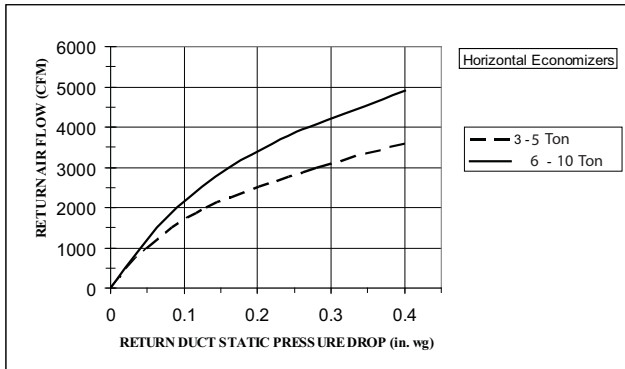

C10474

**Fig. 22 - Return Air Pressure Drop-Horizontal 3-10 Ton**

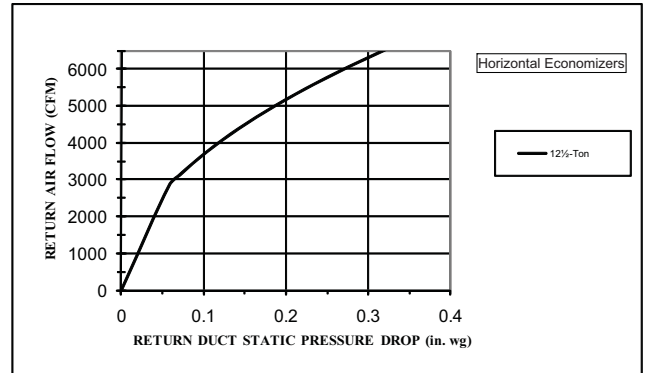

C101003

**Fig. 24 - Return Air Pressure Drop-Horizontal-12.5 Ton**

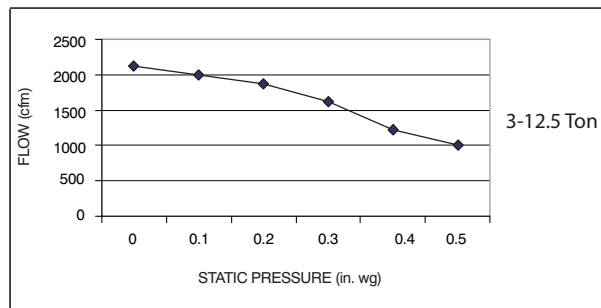

C10995

**Fig. 25 - Horizontal Power Exhaust Performance**

## GENERAL FAN PERFORMANCE NOTES:

1. Interpolation is permissible. Do not extrapolate.
2. External static pressure is the static pressure difference between the return duct and the supply duct plus the static pressure caused by any FIOPs or accessories.
3. Tabular data accounts for pressure loss due to clean filters, unit casing, and wet coils. Factory options and accessories may add static pressure losses. Selection software is available, through your salesperson, to help you select the best motor/drive combination for your application.
4. The Fan Performance tables offer motor/drive recommendations. In cases when two motor/drive combinations would work, ICP recommended the lower horsepower option.
5. For information on the electrical properties of ICP motors, please see the Electrical information section of this book.
6. For more information on the performance limits of ICP motors, see the application data section of this book.
7. The EPACT (Energy Policy Act of 1992) regulates energy requirements for specific types of indoor fan motors. Motors regulated by EPACT include any general purpose, T-frame (three-digit, 143 and larger), single-speed, foot mounted, polyphase, squirrel cage induction motors of NEMA (National Electrical Manufacturers Association) design A and B, manufactured for use in the United States. Ranging from 1 to 200 Hp, these continuous-duty motors operate on 230 and 460 volt, 60 Hz power. If a motor does not fit into these specifications, the motor does not have to be replaced by an EPACT compliant energy-efficient motor. Variable-speed motors are exempt from EPACT compliance requirements.

# FAN PERFORMANCE (BELT DRIVE)

**Table 33 – RGH036**

**3 PHASE NON-HOT GAS RE-HEAT**

**3 TON VERTICAL SUPPLY**

CFM	Available External Static Pressure (in. wg)									
	0.2		0.4		0.6		0.8		1.0	
	RPM	BHP	RPM	BHP	RPM	BHP	RPM	BHP	RPM	BHP
900	<b>592</b>	<b>0.14</b>	<b>721</b>	<b>0.25</b>	826	0.38	916	0.53	997	0.69
975	<b>616</b>	<b>0.17</b>	<b>744</b>	<b>0.28</b>	847	0.41	936	0.56	1016	0.72
1050	<b>641</b>	<b>0.19</b>	<b>766</b>	<b>0.30</b>	868	0.44	957	0.59	1036	0.76
1125	<b>667</b>	<b>0.22</b>	790	0.33	890	0.47	978	0.63	1056	0.80
1200	<b>693</b>	<b>0.25</b>	813	0.37	913	0.51	999	0.67	1077	0.84
1275	<b>720</b>	<b>0.29</b>	837	0.41	935	0.55	1021	0.71	1098	0.88
1350	<b>747</b>	<b>0.33</b>	862	0.45	958	0.60	1043	0.76	1119	0.94
1425	775	0.37	887	0.50	982	0.65	1066	0.81	1141	0.99
1500	802	0.42	912	0.55	1006	0.70	1088	0.87	1163	1.05

CFM	Available External Static Pressure (in. wg)									
	1.2		1.4		1.6		1.8		2.0	
	RPM	BHP	RPM	BHP	RPM	BHP	RPM	BHP	RPM	BHP
900	1070	0.88	1137	1.07	1201	1.29	1260	1.51	1317	1.75
975	1089	0.91	1156	1.11	1219	1.32	1279	1.54	1335	1.78
1050	1108	0.94	1175	1.14	1238	1.36	1297	1.58	1353	1.82
1125	1128	0.98	1195	1.18	1257	1.40	1316	1.62	1372	1.86
1200	1148	1.03	1214	1.23	1276	1.44	1335	1.67	1391	1.91
1275	1169	1.07	1235	1.28	1296	1.50	1354	1.72	1410	1.97
1350	1190	1.13	1255	1.33	1316	1.55	1374	1.78	1429	2.03
1425	1211	1.19	1276	1.39	1337	1.61	1394	1.85	1449	2.09
1500	1232	1.25	1297	1.46	1357	1.68	1415	1.91	<b>1469</b>	<b>2.16</b>

**NOTE:** For more information, see General Fan Performance Notes.  
**Boldface** indicates field-supplied drive is required.

Medium static 770–1175 RPM, 1.7 BHP max  
 High static 1035–1466 RPM, 2.4 BHP max

**Table 34 – RGH036**

**3 PHASE HOT GAS RE-HEAT**

**3 TON VERTICAL SUPPLY**

CFM	Available External Static Pressure (in. wg)									
	0.2		0.4		0.6		0.8		1.0	
	RPM	BHP	RPM	BHP	RPM	BHP	RPM	BHP	RPM	BHP
900	592	0.14	721	0.25	826	0.38	916	0.53	997	0.69
975	616	0.17	744	0.28	847	0.41	936	0.56	1016	0.72
1050	641	0.19	766	0.30	868	0.44	957	0.59	1036	0.76
1125	667	0.22	790	0.33	890	0.47	978	0.63	1056	0.80
1200	693	0.25	813	0.37	913	0.51	999	0.67	1077	0.84
1275	720	0.29	837	0.41	935	0.55	1021	0.71	1098	0.88
1350	747	0.33	862	0.45	958	0.60	1043	0.76	1119	0.94
1425	775	0.37	887	0.50	982	0.65	1066	0.81	1141	0.99
1500	802	0.42	912	0.55	1006	0.70	1088	0.87	1163	1.05

CFM	Available External Static Pressure (in. wg)									
	1.2		1.4		1.6		1.8		2.0	
	RPM	BHP	RPM	BHP	RPM	BHP	RPM	BHP	RPM	BHP
900	1070	0.88	1137	1.07	1201	1.29	1260	1.51	1317	1.75
975	1089	0.91	1156	1.11	1219	1.32	1279	1.54	1335	1.78
1050	1108	0.94	1175	1.14	1238	1.36	1297	1.58	1353	1.82
1125	1128	0.98	1195	1.18	1257	1.40	1316	1.62	1372	1.86
1200	1148	1.03	1214	1.23	1276	1.44	1335	1.67	1391	1.91
1275	1169	1.07	1235	1.28	1296	1.50	1354	1.72	1410	1.97
1350	1190	1.13	1255	1.33	1316	1.55	1374	1.78	1429	2.03
1425	1211	1.19	1276	1.39	1337	1.61	1394	1.85	1449	2.09
1500	1232	1.25	1297	1.46	1357	1.68	1415	1.91	<b>1469</b>	<b>2.16</b>

**NOTE:** For more information, see General Fan Performance Notes.  
**Boldface** indicates field-supplied drive is required.

Standard static 560–854 RPM, 1.7 BHP max  
 Medium static 770–1175 RPM, 1.7 BHP max  
 High static 1035–1466 RPM, 2.4 BHP max

# FAN PERFORMANCE (BELT DRIVE) cont

**Table 35 – RGH036**

**3 PHASE NON-HOT GAS RE-HEAT**

**3 TON HORIZONTAL SUPPLY**

CFM	Available External Static Pressure (in. wg)									
	0.2		0.4		0.6		0.8		1.0	
	RPM	BHP	RPM	BHP	RPM	BHP	RPM	BHP	RPM	BHP
900	<b>582</b>	<b>0.14</b>	<b>715</b>	<b>0.24</b>	825	0.35	921	0.48	1007	0.63
975	<b>606</b>	<b>0.16</b>	<b>735</b>	<b>0.26</b>	843	0.38	938	0.51	1023	0.66
1050	<b>630</b>	<b>0.18</b>	<b>756</b>	<b>0.29</b>	862	0.41	955	0.55	1040	0.70
1125	<b>655</b>	<b>0.21</b>	778	0.32	882	0.45	974	0.58	1057	0.74
1200	<b>681</b>	<b>0.24</b>	800	0.35	902	0.48	992	0.63	1074	0.78
1275	<b>708</b>	<b>0.27</b>	823	0.39	923	0.53	1012	0.67	1093	0.83
1350	<b>735</b>	<b>0.31</b>	847	0.43	945	0.57	1032	0.72	1112	0.88
1425	<b>762</b>	<b>0.35</b>	871	0.48	967	0.62	1053	0.77	1131	0.94
1500	<b>790</b>	<b>0.40</b>	896	0.53	990	0.67	1074	0.83	1151	1.00

CFM	Available External Static Pressure (in. wg)									
	1.2		1.4		1.6		1.8		2.0	
	RPM	BHP	RPM	BHP	RPM	BHP	RPM	BHP	RPM	BHP
900	1086	0.79	1159	0.96	1228	1.14	1293	1.33	1354	1.53
975	1101	0.82	1174	0.99	1242	1.18	1306	1.37	1367	1.57
1050	1117	0.86	1189	1.03	1256	1.22	1320	1.41	1381	1.62
1125	1133	0.90	1204	1.08	1271	1.26	1335	1.46	1395	1.67
1200	1150	0.95	1221	1.13	1287	1.31	1350	1.51	1410	1.72
1275	1168	1.00	1237	1.18	1303	1.37	1365	1.57	1425	1.78
1350	1186	1.05	1255	1.24	1320	1.43	1382	1.63	1441	1.84
1425	1204	1.11	1272	1.30	1337	1.49	1398	1.70	1457	1.91
1500	1223	1.18	1291	1.36	1355	1.56	1415	1.77	<b>1473</b>	<b>1.99</b>

**NOTE:** For more information, see General Fan Performance Notes.  
**Boldface** indicates field-supplied drive is required.

Medium static 770–1175 RPM, 1.7 BHP max

High static 1035–1466 RPM, 2.4 BHP max

**Table 36 – RGH036**

**3 PHASE HOT GAS RE-HEAT**

**3 TON HORIZONTAL SUPPLY**

CFM	Available External Static Pressure (in. wg)									
	0.2		0.4		0.6		0.8		1.0	
	RPM	BHP	RPM	BHP	RPM	BHP	RPM	BHP	RPM	BHP
900	582	0.14	715	0.24	825	0.35	921	0.48	1007	0.63
975	606	0.16	735	0.26	843	0.38	938	0.51	1023	0.66
1050	630	0.18	756	0.29	862	0.41	955	0.55	1040	0.70
1125	655	0.21	778	0.32	882	0.45	974	0.58	1057	0.74
1200	681	0.24	800	0.35	902	0.48	992	0.63	1074	0.78
1275	708	0.27	823	0.39	923	0.53	1012	0.67	1093	0.83
1350	735	0.31	847	0.43	945	0.57	1032	0.72	1112	0.88
1425	762	0.35	871	0.48	967	0.62	1053	0.77	1131	0.94
1500	790	0.40	896	0.53	990	0.67	1074	0.83	1151	1.00

CFM	Available External Static Pressure (in. wg)									
	1.2		1.4		1.6		1.8		2.0	
	RPM	BHP	RPM	BHP	RPM	BHP	RPM	BHP	RPM	BHP
900	1086	0.79	1159	0.96	1228	1.14	1293	1.33	1354	1.53
975	1101	0.82	1174	0.99	1242	1.18	1306	1.37	1367	1.57
1050	1117	0.86	1189	1.03	1256	1.22	1320	1.41	1381	1.62
1125	1133	0.90	1204	1.08	1271	1.26	1335	1.46	1395	1.67
1200	1150	0.95	1221	1.13	1287	1.31	1350	1.51	1410	1.72
1275	1168	1.00	1237	1.18	1303	1.37	1365	1.57	1425	1.78
1350	1186	1.05	1255	1.24	1320	1.43	1382	1.63	1441	1.84
1425	1204	1.11	1272	1.30	1337	1.49	1398	1.70	1457	1.91
1500	1223	1.18	1291	1.36	1355	1.56	1415	1.77	<b>1473</b>	<b>1.99</b>

**NOTE:** For more information, see General Fan Performance Notes.  
**Boldface** indicates field-supplied drive is required.

Standard static 560–864 RPM, 1.7 BHP max

Medium static 770–1175 RPM, 1.7 BHP max

High static 1035–1466 RPM, 2.4 BHP max

# FAN PERFORMANCE (BELT DRIVE) cont

**Table 37 – RGH048**

**3 PHASE NON-HOT GAS RE-HEAT**

**4 TON VERTICAL SUPPLY**

CFM	Available External Static Pressure (in. wg)									
	0.2		0.4		0.6		0.8		1.0	
	RPM	BHP	RPM	BHP	RPM	BHP	RPM	BHP	RPM	BHP
1200	<b>693</b>	<b>0.25</b>	<b>813</b>	<b>0.37</b>	<b>913</b>	<b>0.51</b>	999	0.67	1077	0.84
1300	<b>729</b>	<b>0.30</b>	<b>846</b>	<b>0.42</b>	943	0.57	1028	0.73	1105	0.90
1400	<b>765</b>	<b>0.35</b>	<b>879</b>	<b>0.48</b>	974	0.63	1058	0.79	1134	0.97
1500	<b>802</b>	<b>0.42</b>	<b>912</b>	<b>0.55</b>	1006	0.70	1088	0.87	1163	1.05
1600	<b>840</b>	<b>0.49</b>	947	0.63	1038	0.78	1119	0.95	1193	1.14
1700	<b>878</b>	<b>0.57</b>	982	0.71	1071	0.87	1151	1.05	1224	1.24
1800	<b>917</b>	<b>0.65</b>	1017	0.81	1105	0.97	1183	1.15	1255	1.35
1900	956	0.75	1053	0.91	1139	1.08	1216	1.27	1287	1.47
2000	995	0.86	1090	1.02	1173	1.20	1249	1.39	1319	1.59

CFM	Available External Static Pressure (in. wg)									
	1.2		1.4		1.6		1.8		2.0	
	RPM	BHP	RPM	BHP	RPM	BHP	RPM	BHP	RPM	BHP
1200	1148	1.03	1214	1.23	1276	1.44	1335	1.67	1391	1.91
1300	1176	1.09	1241	1.30	1303	1.51	1361	1.74	1416	1.98
1400	1204	1.17	1269	1.37	1330	1.59	1388	1.82	1442	2.07
1500	1232	1.25	1297	1.46	1357	1.68	1415	1.91	1469	2.16
1600	1262	1.34	1325	1.55	1385	1.78	1442	2.01	1496	2.26
1700	1291	1.44	1354	1.66	1414	1.89	1470	2.12	1524	2.37
1800	1322	1.55	1384	1.77	1443	2.00	1499	2.25	-	-
1900	1352	1.68	1414	1.90	1472	2.13	1528	2.38	-	-
2000	1384	1.81	1445	2.04	1502	2.27	-	-	-	-

**NOTE:** For more information, see General Fan Performance Notes.  
**Boldface** indicates field-supplied drive is required.

Medium static 920–1303 RPM, 1.7 BHP max  
 High static 1208–1550 RPM, 2.9 BHP max

**Table 38 – RGH048**

**3 PHASE HOT GAS RE-HEAT**

**4 TON VERTICAL SUPPLY**

CFM	Available External Static Pressure (in. wg)									
	0.2		0.4		0.6		0.8		1.0	
	RPM	BHP	RPM	BHP	RPM	BHP	RPM	BHP	RPM	BHP
1200	693	0.25	813	0.37	913	0.51	999	0.67	1077	0.84
1300	729	0.30	846	0.42	943	0.57	1028	0.73	1105	0.90
1400	765	0.35	879	0.48	974	0.63	1058	0.79	1134	0.97
1500	802	0.42	912	0.55	1006	0.70	1088	0.87	1163	1.05
1600	840	0.49	947	0.63	1038	0.78	1119	0.95	1193	1.14
1700	878	0.57	982	0.71	1071	0.87	1151	1.05	1224	1.24
1800	917	0.65	1017	0.81	1105	0.97	1183	1.15	1255	1.35
1900	956	0.75	1053	0.91	1139	1.08	1216	1.27	1287	1.47
2000	995	0.86	1090	1.02	1173	1.20	1249	1.39	1319	1.59

CFM	Available External Static Pressure (in. wg)									
	1.2		1.4		1.6		1.8		2.0	
	RPM	BHP	RPM	BHP	RPM	BHP	RPM	BHP	RPM	BHP
1200	1148	1.03	1214	1.23	1276	1.44	1335	1.67	1391	1.91
1300	1176	1.09	1241	1.30	1303	1.51	1361	1.74	1416	1.98
1400	1204	1.17	1269	1.37	1330	1.59	1388	1.82	1442	2.07
1500	1232	1.25	1297	1.46	1357	1.68	1415	1.91	1469	2.16
1600	1262	1.34	1325	1.55	1385	1.78	1442	2.01	1496	2.26
1700	1291	1.44	1354	1.66	1414	1.89	1470	2.12	1524	2.37
1800	1322	1.55	1384	1.77	1443	2.00	1499	2.25	-	-
1900	1352	1.68	1414	1.90	1472	2.13	1528	2.38	-	-
2000	1384	1.81	1445	2.04	1502	2.27	-	-	-	-

**NOTE:** For more information, see General Fan Performance Notes.

Standard static 560–854 RPM, 1.7 BHP max  
 Medium static 770–1175 RPM, 1.7 BHP max  
 High static 1208–1550 RPM, 2.9 BHP max

# FAN PERFORMANCE (BELT DRIVE) cont

**Table 39 – RGH048**

**3 PHASE NON-HOT GAS RE-HEAT**

**4 TON HORIZONTAL SUPPLY**

CFM	Available External Static Pressure (in. wg)									
	0.2		0.4		0.6		0.8		1.0	
	RPM	BHP	RPM	BHP	RPM	BHP	RPM	BHP	RPM	BHP
1200	<b>681</b>	<b>0.24</b>	<b>800</b>	<b>0.35</b>	<b>902</b>	<b>0.48</b>	992	0.63	1074	0.78
1300	<b>717</b>	<b>0.29</b>	<b>831</b>	<b>0.41</b>	930	0.54	1019	0.69	1099	0.85
1400	<b>753</b>	<b>0.34</b>	<b>863</b>	<b>0.46</b>	959	0.60	1046	0.75	1125	0.92
1500	<b>790</b>	<b>0.40</b>	<b>896</b>	<b>0.53</b>	990	0.67	1074	0.83	1151	1.00
1600	<b>828</b>	<b>0.46</b>	930	0.60	1021	0.75	1103	0.91	1179	1.09
1700	<b>866</b>	<b>0.54</b>	964	0.68	1053	0.84	1133	1.01	1207	1.18
1800	<b>905</b>	<b>0.62</b>	1000	0.77	1085	0.94	1164	1.11	1236	1.29
1900	944	0.71	1036	0.87	1119	1.04	1195	1.22	1266	1.41
2000	984	0.82	1072	0.98	1153	1.15	1227	1.34	1297	1.53

CFM	Available External Static Pressure (in. wg)									
	1.2		1.4		1.6		1.8		2.0	
	RPM	BHP	RPM	BHP	RPM	BHP	RPM	BHP	RPM	BHP
1200	1150	0.95	1221	1.13	1287	1.31	1350	1.51	1410	1.72
1300	1173	1.02	1243	1.20	1309	1.39	1371	1.59	1430	1.80
1400	1198	1.09	1266	1.28	1331	1.47	1393	1.68	1451	1.89
1500	1223	1.18	1291	1.36	1355	1.56	1415	1.77	1473	1.99
1600	1249	1.27	1316	1.46	1379	1.66	1439	1.87	1496	2.09
1700	1277	1.37	1342	1.57	1404	1.77	1463	1.99	1520	2.21
1800	1305	1.48	1369	1.68	1430	1.89	1489	2.11	1545	2.34
1900	1333	1.60	1397	1.81	1457	2.02	1514	2.25	-	-
2000	1363	1.73	1425	1.94	1484	2.16	1541	2.39	-	-

**NOTE:** For more information, see General Fan Performance Notes.

**Boldface** indicates field-supplied drive is required.

Medium static 920–1303 RPM, 1.7 BHP max

High static 1208–1550 RPM, 2.9 BHP max

**Table 40 – RGH048**

**3 PHASE HOT GAS RE-HEAT**

**4 TON HORIZONTAL SUPPLY**

CFM	Available External Static Pressure (in. wg)									
	0.2		0.4		0.6		0.8		1.0	
	RPM	BHP	RPM	BHP	RPM	BHP	RPM	BHP	RPM	BHP
1200	681	0.24	800	0.35	902	0.48	992	0.63	1074	0.78
1300	717	0.29	831	0.41	930	0.54	1019	0.69	1099	0.85
1400	753	0.34	863	0.46	959	0.60	1046	0.75	1125	0.92
1500	790	0.40	896	0.53	990	0.67	1074	0.83	1151	1.00
1600	828	0.46	930	0.60	1021	0.75	1103	0.91	1179	1.09
1700	866	0.54	964	0.68	1053	0.84	1133	1.01	1207	1.18
1800	905	0.62	1000	0.77	1085	0.94	1164	1.11	1236	1.29
1900	944	0.71	1036	0.87	1119	1.04	1195	1.22	1266	1.41
2000	984	0.82	1072	0.98	1153	1.15	1227	1.34	1297	1.53

CFM	Available External Static Pressure (in. wg)									
	1.2		1.4		1.6		1.8		2.0	
	RPM	BHP	RPM	BHP	RPM	BHP	RPM	BHP	RPM	BHP
1200	1150	0.95	1221	1.13	1287	1.31	1350	1.51	1410	1.72
1300	1173	1.02	1243	1.20	1309	1.39	1371	1.59	1430	1.80
1400	1198	1.09	1266	1.28	1331	1.47	1393	1.68	1451	1.89
1500	1223	1.18	1291	1.36	1355	1.56	1415	1.77	1473	1.99
1600	1249	1.27	1316	1.46	1379	1.66	1439	1.87	1496	2.09
1700	1277	1.37	1342	1.57	1404	1.77	1463	1.99	1520	2.21
1800	1305	1.48	1369	1.68	1430	1.89	1489	2.11	1545	2.34
1900	1333	1.60	1397	1.81	1457	2.02	1514	2.25	-	-
2000	1363	1.73	1425	1.94	1484	2.16	1541	2.39	-	-

**NOTE:** For more information, see General Fan Performance Notes.

Standard static 560–854 RPM, 1.7 BHP max

Medium static 770–1175 RPM, 1.7 BHP max

High static 1208–1550 RPM, 2.9 BHP max

# FAN PERFORMANCE (BELT DRIVE) cont

**Table 41 – RGH060**

**3 PHASE NON-HOT GAS RE-HEAT**

**5 TON VERTICAL SUPPLY**

CFM	Available External Static Pressure (in. wg)									
	0.2		0.4		0.6		0.8		1.0	
	RPM	BHP	RPM	BHP	RPM	BHP	RPM	BHP	RPM	BHP
1500	<b>847</b>	<b>0.41</b>	966	0.55	1067	0.68	1158	0.81	1240	0.93
1625	<b>896</b>	<b>0.50</b>	1010	0.65	1109	0.79	1198	0.93	1278	1.07
1750	<b>947</b>	<b>0.59</b>	1056	0.76	1152	0.92	1238	1.07	1318	1.22
1875	<b>998</b>	<b>0.70</b>	1103	0.88	1196	1.05	1280	1.22	1358	1.38
2000	1049	0.82	1151	1.02	1241	1.20	1323	1.38	1399	1.56
2125	1102	0.96	1199	1.17	1287	1.37	1367	1.56	1441	1.75
2250	1154	1.11	1248	1.33	1333	1.55	1411	1.75	1484	1.96
2375	1208	1.28	1298	1.52	1381	1.74	1457	1.96	1528	2.18
2500	1261	1.47	1349	1.72	1429	1.96	1503	2.19	-	-

CFM	Available External Static Pressure (in. wg)									
	1.2		1.4		1.6		1.8		2.0	
	RPM	BHP	RPM	BHP	RPM	BHP	RPM	BHP	RPM	BHP
1500	1316	1.05	1387	1.17	1454	1.28	1517	1.39	-	-
1625	1353	1.20	1423	1.33	1489	1.46	-	-	-	-
1750	1391	1.36	1460	1.51	1525	1.65	-	-	-	-
1875	1430	1.54	1498	1.70	-	-	-	-	-	-
2000	1470	1.73	1537	1.90	-	-	-	-	-	-
2125	1511	1.93	-	-	-	-	-	-	-	-
2250	-	-	-	-	-	-	-	-	-	-
2375	-	-	-	-	-	-	-	-	-	-
2500	-	-	-	-	-	-	-	-	-	-

**NOTE:** For more information, see General Fan Performance Notes.

**Boldface** indicates field-supplied drive is required.

Medium static 1035–1466 RPM, 2.4 BHP max

High static 1303 – 1550 RPM, 2.9 BHP max

**Table 42 – RGH060**

**3 PHASE HOT GAS RE-HEAT**

**5 TON VERTICAL SUPPLY**

CFM	Available External Static Pressure (in. wg)									
	0.2		0.4		0.6		0.8		1.0	
	RPM	BHP	RPM	BHP	RPM	BHP	RPM	BHP	RPM	BHP
1500	847	0.41	966	0.55	1067	0.68	1158	0.81	1240	0.93
1625	896	0.50	1010	0.65	1109	0.79	1198	0.93	1278	1.07
1750	947	0.59	1056	0.76	1152	0.92	1238	1.07	1318	1.22
1875	998	0.70	1103	0.88	1196	1.05	1280	1.22	1358	1.38
2000	1049	0.82	1151	1.02	1241	1.20	1323	1.38	1399	1.56
2125	1102	0.96	1199	1.17	1287	1.37	1367	1.56	1441	1.75
2250	1154	1.11	1248	1.33	1333	1.55	1411	1.75	1484	1.96
2375	1208	1.28	1298	1.52	1381	1.74	1457	1.96	1528	2.18
2500	1261	1.47	1349	1.72	1429	1.96	1503	2.19	-	-

CFM	Available External Static Pressure (in. wg)									
	1.2		1.4		1.6		1.8		2.0	
	RPM	BHP	RPM	BHP	RPM	BHP	RPM	BHP	RPM	BHP
1500	1316	1.05	1387	1.17	1454	1.28	1517	1.39	-	-
1625	1353	1.20	1423	1.33	1489	1.46	-	-	-	-
1750	1391	1.36	1460	1.51	1525	1.65	-	-	-	-
1875	1430	1.54	1498	1.70	-	-	-	-	-	-
2000	1470	1.73	1537	1.90	-	-	-	-	-	-
2125	1511	1.93	-	-	-	-	-	-	-	-
2250	-	-	-	-	-	-	-	-	-	-
2375	-	-	-	-	-	-	-	-	-	-
2500	-	-	-	-	-	-	-	-	-	-

**NOTE:** For more information, see General Fan Performance Notes.

Standard static 770–1175 RPM, 1.7 BHP max

Medium static 1035–1466 RPM, 2.4 BHP max

High static 1303–1550 RPM, 2.9 BHP max

# FAN PERFORMANCE (BELT DRIVE) cont

**Table 43 – RGH060**

**3 PHASE NON-HOT GAS RE-HEAT**

**5 TON HORIZONTAL SUPPLY**

CFM	Available External Static Pressure (in. wg)									
	0.2		0.4		0.6		0.8		1.0	
	RPM	BHP	RPM	BHP	RPM	BHP	RPM	BHP	RPM	BHP
1500	<b>798</b>	<b>0.41</b>	906	0.55	1002	0.71	1088	0.87	1167	1.05
1625	<b>845</b>	<b>0.50</b>	949	0.65	1041	0.81	1125	0.98	1202	1.17
1750	<b>893</b>	<b>0.60</b>	993	0.76	1081	0.93	1163	1.11	1238	1.30
1875	<b>942</b>	<b>0.71</b>	1037	0.88	1123	1.06	1202	1.25	1275	1.44
2000	<b>992</b>	<b>0.84</b>	1083	1.02	1166	1.21	1242	1.40	1313	1.61
2125	1043	0.98	1129	1.17	1209	1.37	1283	1.57	1353	1.79
2250	1093	1.14	1177	1.34	1254	1.55	1325	1.76	1393	1.98
2375	1145	1.32	1225	1.53	1299	1.74	1369	1.97	1434	2.20
2500	1196	1.51	1273	1.73	1345	1.96	1413	2.19	1477	2.43

CFM	Available External Static Pressure (in. wg)									
	1.2		1.4		1.6		1.8		2.0	
	RPM	BHP	RPM	BHP	RPM	BHP	RPM	BHP	RPM	BHP
1500	1241	1.23	1310	1.42	1375	1.63	1438	1.84	1497	2.06
1625	1274	1.36	1342	1.56	1406	1.77	1467	1.98	1526	2.21
1750	1308	1.50	1375	1.70	1438	1.92	1498	2.14	-	-
1875	1344	1.65	1409	1.86	1471	2.09	1530	2.32	-	-
2000	1380	1.82	1444	2.04	1505	2.27	-	-	-	-
2125	1418	2.01	1481	2.24	1540	2.47	-	-	-	-
2250	1457	2.21	1518	2.45	-	-	-	-	-	-
2375	1497	2.43	-	-	-	-	-	-	-	-
2500	1538	2.68	-	-	-	-	-	-	-	-

**NOTE:** For more information, see General Fan Performance Notes.

**Boldface** indicates field-supplied drive is required.

Medium static 1035–1466 RPM, 2.4 BHP max

High static 1303–1550 RPM, 2.9 BHP max

**Table 44 – RGH060**

**3 PHASE HOT GAS RE-HEAT**

**5 TON HORIZONTAL SUPPLY**

CFM	Available External Static Pressure (in. wg)									
	0.2		0.4		0.6		0.8		1.0	
	RPM	BHP	RPM	BHP	RPM	BHP	RPM	BHP	RPM	BHP
1500	798	0.41	906	0.55	1002	0.71	1088	0.87	1167	1.05
1625	845	0.50	949	0.65	1041	0.81	1125	0.98	1202	1.17
1750	893	0.60	993	0.76	1081	0.93	1163	1.11	1238	1.30
1875	942	0.71	1037	0.88	1123	1.06	1202	1.25	1275	1.44
2000	992	0.84	1083	1.02	1166	1.21	1242	1.40	1313	1.61
2125	1043	0.98	1129	1.17	1209	1.37	1283	1.57	1353	1.79
2250	1093	1.14	1177	1.34	1254	1.55	1325	1.76	1393	1.98
2375	1145	1.32	1225	1.53	1299	1.74	1369	1.97	1434	2.20
2500	1196	1.51	1273	1.73	1345	1.96	1413	2.19	1477	2.43

CFM	Available External Static Pressure (in. wg)									
	1.2		1.4		1.6		1.8		2.0	
	RPM	BHP	RPM	BHP	RPM	BHP	RPM	BHP	RPM	BHP
1500	1241	1.23	1310	1.42	1375	1.63	1438	1.84	1497	2.06
1625	1274	1.36	1342	1.56	1406	1.77	1467	1.98	1526	2.21
1750	1308	1.50	1375	1.70	1438	1.92	1498	2.14	-	-
1875	1344	1.65	1409	1.86	1471	2.09	1530	2.32	-	-
2000	1380	1.82	1444	2.04	1505	2.27	-	-	-	-
2125	1418	2.01	1481	2.24	1540	2.47	-	-	-	-
2250	1457	2.21	1518	2.45	-	-	-	-	-	-
2375	1497	2.43	-	-	-	-	-	-	-	-
2500	1538	2.68	-	-	-	-	-	-	-	-

**NOTE:** For more information, see General Fan Performance Notes.

Standard static 770–1175 RPM, 1.7 BHP max

Medium static 1035–1466 RPM, 2.4 BHP max

High static 1303–1550 RPM, 2.9 BHP max

# FAN PERFORMANCE (BELT DRIVE) cont

**Table 45 – RGH072/RGH073**

**3 PHASE**

**6 TON VERTICAL SUPPLY**

CFM	Available External Static Pressure (in. wg)									
	0.2		0.4		0.6		0.8		1.0	
	RPM	BHP	RPM	BHP	RPM	BHP	RPM	BHP	RPM	BHP
1800	449	0.34	539	0.53	615	0.75	681	0.99	742	1.26
1950	470	0.40	557	0.60	631	0.83	696	1.08	756	1.35
2100	491	0.47	576	0.68	648	0.91	712	1.17	771	1.45
2250	513	0.54	595	0.76	665	1.01	728	1.27	786	1.56
2400	536	0.63	615	0.86	684	1.11	745	1.39	802	1.68
2550	558	0.72	635	0.97	702	1.23	763	1.51	818	1.81
2700	582	0.83	656	1.08	721	1.35	781	1.65	835	1.95
2850	605	0.94	677	1.21	741	1.49	799	1.79	853	2.11
3000	629	1.07	699	1.35	761	1.64	818	1.95	871	2.28

CFM	Available External Static Pressure (in. wg)									
	1.2		1.4		1.6		1.8		2.0	
	RPM	BHP	RPM	BHP	RPM	BHP	RPM	BHP	RPM	BHP
1800	797	1.54	848	1.84	896	2.16	942	2.49	985	2.84
1950	810	1.64	861	1.94	909	2.26	954	2.60	997	2.96
2100	824	1.74	875	2.06	922	2.38	967	2.73	1009	3.09
2250	839	1.86	889	2.18	935	2.52	980	2.87	1022	3.23
2400	854	1.99	903	2.32	950	2.66	993	3.02	1035	3.39
2550	870	2.13	918	2.46	964	2.81	1008	3.18	1049	3.55
2700	886	2.28	934	2.62	979	2.98	1022	3.35	1063	3.74
2850	903	2.44	950	2.79	995	3.16	1037	3.54	1078	3.93
3000	920	2.62	966	2.98	1010	3.35	1052	3.74	1093	4.14

**NOTE:** For more information, see General Fan Performance Notes.

- Standard static 489 – 747 RPM, 1.7 BHP max
- Medium static 733 – 949 RPM, 2.9 BHP max
- High static 909 – 1102 RPM, 4.7 BHP max

**Table 46 – RGH072/RGH073**

**3 PHASE**

**6 TON HORIZONTAL SUPPLY**

CFM	Available External Static Pressure (in. wg)									
	0.2		0.4		0.6		0.8		1.0	
	RPM	BHP	RPM	BHP	RPM	BHP	RPM	BHP	RPM	BHP
1800	441	0.33	533	0.51	611	0.72	681	0.96	745	1.23
1950	462	0.38	550	0.58	626	0.80	694	1.04	757	1.31
2100	483	0.45	567	0.65	641	0.88	708	1.13	769	1.40
2250	505	0.52	586	0.73	657	0.97	722	1.22	782	1.50
2400	528	0.60	605	0.82	674	1.07	738	1.33	796	1.62
2550	550	0.69	625	0.92	692	1.17	754	1.45	811	1.74
2700	574	0.80	645	1.03	710	1.29	770	1.57	826	1.88
2850	597	0.91	666	1.16	729	1.43	788	1.71	843	2.02
3000	621	1.03	688	1.29	749	1.57	806	1.87	859	2.18

CFM	Available External Static Pressure (in. wg)									
	1.2		1.4		1.6		1.8		2.0	
	RPM	BHP	RPM	BHP	RPM	BHP	RPM	BHP	RPM	BHP
1800	804	1.51	860	1.82	912	2.15	961	2.49	1008	2.85
1950	815	1.60	869	1.91	920	2.24	969	2.59	1016	2.96
2100	826	1.70	880	2.01	930	2.35	978	2.70	1024	3.07
2250	838	1.81	891	2.12	941	2.46	988	2.82	1033	3.19
2400	851	1.92	903	2.25	952	2.59	999	2.95	1043	3.33
2550	865	2.05	916	2.38	964	2.73	1010	3.10	1054	3.48
2700	879	2.19	929	2.53	976	2.88	1022	3.25	1066	3.64
2850	894	2.35	943	2.69	990	3.05	1035	3.43	1078	3.82
3000	910	2.51	958	2.86	1004	3.23	1048	3.61	1090	4.01

**NOTE:** For more information, see General Fan Performance Notes.

- Standard static 489 – 747 RPM, 1.7 BHP max
- Medium static 733 – 949 RPM, 2.9 BHP max
- High static 909 – 1102 RPM, 4.7 BHP max

# FAN PERFORMANCE (BELT DRIVE) cont

**Table 47 – RGH090**

**3 PHASE**

**7.5 TON VERTICAL SUPPLY**

CFM	Available External Static Pressure (in. wg)									
	0.2		0.4		0.6		0.8		1.0	
	RPM	BHP	RPM	BHP	RPM	BHP	RPM	BHP	RPM	BHP
2250	505	0.39	595	0.54	676	0.69	750	0.86	819	1.03
2438	532	0.47	617	0.63	694	0.79	766	0.97	833	1.15
2625	559	0.56	640	0.73	714	0.90	783	1.08	848	1.28
2813	588	0.67	664	0.84	735	1.03	801	1.22	864	1.42
3000	616	0.79	689	0.97	757	1.16	821	1.36	882	1.57
3188	646	0.92	715	1.11	780	1.31	842	1.52	901	1.74
3375	675	1.06	742	1.27	804	1.48	864	1.70	920	1.93
3563	705	1.23	769	1.44	829	1.66	886	1.89	941	2.13
3750	736	1.41	797	1.63	855	1.86	910	2.10	963	2.35

CFM	Available External Static Pressure (in. wg)									
	1.2		1.4		1.6		1.8		2.0	
	RPM	BHP	RPM	BHP	RPM	BHP	RPM	BHP	RPM	BHP
2250	884	1.21	945	1.40	1003	1.60	1059	1.80	<b>1112</b>	<b>2.01</b>
2438	896	1.34	955	1.54	1012	1.74	1066	1.95	<b>1118</b>	<b>2.17</b>
2625	909	1.47	967	1.68	1022	1.89	1075	2.11	<b>1126</b>	<b>2.34</b>
2813	923	1.62	980	1.84	1034	2.06	1086	2.29	<b>1136</b>	<b>2.52</b>
3000	939	1.79	994	2.01	1047	2.24	<b>1098</b>	<b>2.47</b>	<b>1147</b>	<b>2.71</b>
3188	956	1.97	1010	2.20	1061	2.43	<b>1111</b>	<b>2.68</b>	<b>1159</b>	<b>2.93</b>
3375	975	2.16	1027	2.40	1077	2.65	<b>1125</b>	<b>2.90</b>	<b>1172</b>	<b>3.15</b>
3563	994	2.37	1044	2.62	<b>1093</b>	<b>2.87</b>	<b>1141</b>	<b>3.13</b>	<b>1186</b>	<b>3.40</b>
3750	1014	2.60	1063	2.86	<b>1111</b>	<b>3.12</b>	<b>1157</b>	<b>3.39</b>	<b>1202</b>	<b>3.66</b>

**NOTE:** For more information, see General Fan Performance Notes.  
**Boldface** indicates field-supplied drive is required.

Standard static 518 – 733 RPM, 1.7 BHP max  
 Medium static 690 – 936 RPM, 2.4 BHP max  
 High static 838 – 1084 RPM, 3.7 BHP max

**Table 48 – RGH090**

**3 PHASE**

**7.5 TON HORIZONTAL SUPPLY**

CFM	Available External Static Pressure (in. wg)									
	0.2		0.4		0.6		0.8		1.0	
	RPM	BHP	RPM	BHP	RPM	BHP	RPM	BHP	RPM	BHP
2250	482	0.36	577	0.51	659	0.66	732	0.82	799	0.98
2438	505	0.43	597	0.59	676	0.75	748	0.92	813	1.09
2625	529	0.51	617	0.68	694	0.85	764	1.03	827	1.22
2813	554	0.60	638	0.78	713	0.97	781	1.16	843	1.35
3000	579	0.70	660	0.89	732	1.09	799	1.29	860	1.50
3188	604	0.81	683	1.02	753	1.23	817	1.44	877	1.65
3375	630	0.94	706	1.15	774	1.37	836	1.60	895	1.82
3563	657	1.08	729	1.31	795	1.54	856	1.77	913	2.01
3750	683	1.23	753	1.47	817	1.71	877	1.96	933	2.21

CFM	Available External Static Pressure (in. wg)									
	1.2		1.4		1.6		1.8		2.0	
	RPM	BHP	RPM	BHP	RPM	BHP	RPM	BHP	RPM	BHP
2250	860	1.14	917	1.31	971	1.48	1022	1.66	1071	1.84
2438	873	1.27	929	1.45	983	1.63	1033	1.81	1081	2.00
2625	887	1.40	942	1.59	995	1.78	1045	1.98	<b>1092</b>	<b>2.18</b>
2813	901	1.55	956	1.75	1008	1.95	1057	2.15	<b>1104</b>	<b>2.36</b>
3000	917	1.70	970	1.91	1021	2.13	1070	2.34	<b>1117</b>	<b>2.56</b>
3188	933	1.87	986	2.09	1036	2.32	1084	2.54	<b>1130</b>	<b>2.77</b>
3375	950	2.05	1002	2.29	1051	2.52	<b>1098</b>	<b>2.76</b>	<b>1144</b>	<b>3.00</b>
3563	967	2.25	1018	2.49	1067	2.74	<b>1113</b>	<b>2.99</b>	<b>1158</b>	<b>3.24</b>
3750	985	2.46	1035	2.71	1083	2.97	<b>1129</b>	<b>3.23</b>	<b>1173</b>	<b>3.49</b>

**NOTE:** For more information, see General Fan Performance Notes.  
**Boldface** indicates field-supplied drive is required.

Standard static 518 – 733 RPM, 1.7 BHP max  
 Medium static 690 – 936 RPM, 2.4 BHP max  
 High static 838 – 1084 RPM, 3.7 BHP max

# FAN PERFORMANCE (BELT DRIVE) cont

**Table 49 – RGH102**

**3 PHASE**

**8.5 TON VERTICAL SUPPLY**

CFM	Available External Static Pressure (in. wg)									
	0.2		0.4		0.6		0.8		1.0	
	RPM	BHP	RPM	BHP	RPM	BHP	RPM	BHP	RPM	BHP
2550	548	0.52	631	0.69	706	0.86	776	1.04	841	1.22
2750	578	0.63	656	0.80	728	0.98	795	1.17	858	1.37
3000	616	0.79	689	0.97	757	1.16	821	1.36	882	1.57
3200	648	0.93	717	1.12	782	1.32	843	1.53	902	1.75
3400	679	1.09	745	1.29	808	1.50	867	1.72	923	1.95
3600	711	1.26	774	1.48	834	1.70	891	1.93	945	2.17
3850	752	1.51	812	1.74	868	1.98	923	2.22	975	2.47
4050	785	1.73	842	1.97	896	2.22	949	2.47	999	2.74
4250	818	1.98	873	2.23	925	2.49	976	2.75	1025	3.02

CFM	Available External Static Pressure (in. wg)									
	1.2		1.4		1.6		1.8		2.0	
	RPM	BHP	RPM	BHP	RPM	BHP	RPM	BHP	RPM	BHP
2550	903	1.42	962	1.62	1018	1.83	1072	2.05	<b>1123</b>	<b>2.27</b>
2750	918	1.57	975	1.78	1030	2.00	1082	2.23	<b>1133</b>	<b>2.46</b>
3000	939	1.79	994	2.01	1047	2.24	<b>1098</b>	<b>2.47</b>	<b>1147</b>	<b>2.71</b>
3200	957	1.96	1011	2.21	1062	2.45	<b>1112</b>	<b>2.69</b>	<b>1160</b>	<b>2.94</b>
3400	977	2.19	1029	2.43	1079	2.67	<b>1127</b>	<b>2.93</b>	<b>1174</b>	<b>3.19</b>
3600	998	2.41	1048	2.66	<b>1097</b>	<b>2.92</b>	<b>1144</b>	<b>3.18</b>	<b>1189</b>	<b>3.45</b>
3850	1025	2.73	1074	2.99	<b>1121</b>	<b>3.26</b>	<b>1166</b>	<b>3.53</b>	<b>1210</b>	<b>3.81</b>
4050	1048	3.00	<b>1095</b>	<b>3.27</b>	<b>1141</b>	<b>3.55</b>	<b>1185</b>	<b>3.83</b>	<b>1228</b>	<b>4.12</b>
4250	1072	3.30	<b>1118</b>	<b>3.58</b>	<b>1162</b>	<b>3.87</b>	<b>1205</b>	<b>4.16</b>	<b>1247</b>	<b>4.48</b>

**NOTE:** For more information, see General Fan Performance Notes.  
**Boldface** indicates field-supplied drive is required.

Standard static 518 – 733 RPM, 1.7 BHP max  
 Medium static 690 – 936 RPM, 2.4 BHP max  
 High static 838 – 1084 RPM, 3.7 BHP max

**Table 50 – RGH102**

**3 PHASE**

**8.5 TON HORIZONTAL SUPPLY**

CFM	Available External Static Pressure (in. wg)									
	0.2		0.4		0.6		0.8		1.0	
	RPM	BHP	RPM	BHP	RPM	BHP	RPM	BHP	RPM	BHP
2550	520	0.47	609	0.64	687	0.81	757	0.99	821	1.16
2750	545	0.57	631	0.75	707	0.93	775	1.11	838	1.30
3000	579	0.70	660	0.89	732	1.09	799	1.29	860	1.50
3200	606	0.82	684	1.03	754	1.24	818	1.45	878	1.66
3400	634	0.95	709	1.17	777	1.40	839	1.62	897	1.85
3600	662	1.10	734	1.34	800	1.57	860	1.81	917	2.05
3850	698	1.32	766	1.56	829	1.81	888	2.07	943	2.32
4050	726	1.50	792	1.76	854	2.03	911	2.29	965	2.56
4250	756	1.71	819	1.98	879	2.26	934	2.53	987	2.81

CFM	Available External Static Pressure (in. wg)									
	1.2		1.4		1.6		1.8		2.0	
	RPM	BHP	RPM	BHP	RPM	BHP	RPM	BHP	RPM	BHP
2550	881	1.35	937	1.53	990	1.72	1040	1.91	<b>1088</b>	<b>2.11</b>
2750	896	1.50	951	1.69	1003	1.89	1053	2.09	<b>1100</b>	<b>2.30</b>
3000	917	1.70	970	1.91	1021	2.13	1070	2.34	<b>1117</b>	<b>2.56</b>
3200	934	1.88	987	2.10	1037	2.33	<b>1085</b>	<b>2.56</b>	<b>1131</b>	<b>2.79</b>
3400	952	2.08	1004	2.31	1053	2.55	<b>1100</b>	<b>2.79</b>	<b>1145</b>	<b>3.03</b>
3600	971	2.29	1022	2.53	1070	2.78	<b>1116</b>	<b>3.03</b>	<b>1161</b>	<b>3.29</b>
3850	995	2.58	1045	2.84	<b>1092</b>	<b>3.10</b>	<b>1138</b>	<b>3.36</b>	<b>1181</b>	<b>3.63</b>
4050	1016	2.83	1064	3.10	<b>1111</b>	<b>3.37</b>	<b>1156</b>	<b>3.65</b>	<b>1199</b>	<b>3.93</b>
4250	1037	3.09	1084	3.38	<b>1130</b>	<b>3.66</b>	<b>1174</b>	<b>3.95</b>	<b>1216</b>	<b>4.24</b>

**NOTE:** For more information, see General Fan Performance Notes.  
**Boldface** indicates field-supplied drive is required.

Standard static 518 – 733 RPM, 1.7 BHP max  
 Medium static 690 – 936 RPM, 2.4 BHP max  
 High static 838 – 1084 RPM, 3.7 BHP max

# FAN PERFORMANCE (BELT DRIVE) cont

**Table 51 – RGH110**

**3 PHASE**

**10 TON VERTICAL SUPPLY**

CFM	Available External Static Pressure (in. wg)									
	0.2		0.4		0.6		0.8		1.0	
	RPM	BHP	RPM	BHP	RPM	BHP	RPM	BHP	RPM	BHP
3000	616	0.79	689	0.97	757	1.16	821	1.36	882	1.57
3250	655	0.96	724	1.16	788	1.37	849	1.58	907	1.80
3500	695	1.17	760	1.38	821	1.60	879	1.83	934	2.06
3750	736	1.41	797	1.63	855	1.86	910	2.10	963	2.35
4000	777	1.68	834	1.91	889	2.16	942	2.41	993	2.67
4250	818	1.98	873	2.23	925	2.49	976	2.75	1025	3.02
4500	860	2.32	912	2.58	962	2.85	1010	3.13	1057	3.41
4750	902	2.69	951	2.97	999	3.26	1046	3.55	1091	3.84
5000	944	3.11	991	3.40	1037	3.70	1082	4.00	1125	4.31

CFM	Available External Static Pressure (in. wg)									
	1.2		1.4		1.6		1.8		2.0	
	RPM	BHP	RPM	BHP	RPM	BHP	RPM	BHP	RPM	BHP
3000	939	1.79	994	2.01	1047	2.24	1098	2.47	1147	2.71
3250	962	2.03	1015	2.26	1066	2.50	1115	2.75	1163	3.00
3500	987	2.30	1038	2.54	1088	2.80	1135	3.05	1181	3.32
3750	1014	2.60	1063	2.86	1111	3.12	1157	3.39	1202	3.66
4000	1042	2.93	1090	3.20	1136	3.48	1180	3.76	1224	4.04
4250	1072	3.30	1118	3.58	1162	3.87	1205	4.16	<b>1247</b>	<b>4.46</b>
4500	1103	3.70	1147	4.00	1190	4.29	1232	4.60	-	-
4750	1135	4.14	1177	4.45	-	-	-	-	-	-
5000	1167	4.63	-	-	-	-	-	-	-	-

**NOTE:** For more information, see General Fan Performance Notes.

**Boldface** indicates field-supplied drive is required.

Standard static 591 – 838 RPM, 2.4 BHP max

Medium static 838 – 1084 RPM, 3.7 BHP max

High static 1022 – 1240 RPM, 4.9 BHP max

**Table 52 – RGH110**

**3 PHASE**

**10 TON HORIZONTAL SUPPLY**

CFM	Available External Static Pressure (in. wg)									
	0.2		0.4		0.6		0.8		1.0	
	RPM	BHP	RPM	BHP	RPM	BHP	RPM	BHP	RPM	BHP
3000	579	0.70	660	0.89	732	1.09	799	1.29	860	1.50
3250	613	0.85	690	1.06	760	1.27	823	1.49	883	1.71
3500	648	1.03	721	1.25	788	1.48	850	1.71	907	1.95
3750	683	1.23	753	1.47	817	1.71	877	1.96	933	2.21
4000	719	1.45	786	1.71	848	1.97	905	2.23	959	2.50
4250	756	1.71	819	1.98	879	2.26	934	2.53	987	2.81
4500	792	1.99	853	2.28	910	2.57	964	2.87	1015	3.16
4750	830	2.31	888	2.62	943	2.92	995	3.23	1044	3.54
5000	867	2.66	923	2.98	976	3.30	1026	3.63	1074	3.95

CFM	Available External Static Pressure (in. wg)									
	1.2		1.4		1.6		1.8		2.0	
	RPM	BHP	RPM	BHP	RPM	BHP	RPM	BHP	RPM	BHP
3000	917	1.70	970	1.91	1021	2.13	1070	2.34	1117	2.56
3250	938	1.93	991	2.16	1041	2.38	1089	2.61	1134	2.85
3500	961	2.18	1013	2.42	1062	2.66	1108	2.91	1153	3.15
3750	985	2.46	1035	2.71	1083	2.97	1129	3.23	1173	3.49
4000	1011	2.76	1059	3.03	1106	3.30	1151	3.58	1194	3.85
4250	1037	3.09	1084	3.38	1130	3.66	1174	3.95	1216	4.24
4500	1064	3.46	1110	3.76	1155	4.06	1198	4.36	1239	4.66
4750	1091	3.85	1137	4.16	1180	4.48	-	-	-	-
5000	1120	4.28	1164	4.61	-	-	-	-	-	-

**NOTE:** For more information, see General Fan Performance Notes.

Standard static 591 – 838 RPM, 2.4 BHP max

Medium static 838 – 1084 RPM, 3.7 BHP max

High static 1022 – 1240 RPM, 4.9 BHP max

# FAN PERFORMANCE (BELT DRIVE) cont

**Table 53 – RGH120**

**3 PHASE**

**10 TON VERTICAL SUPPLY**

CFM	Available External Static Pressure (in. wg)									
	0.2		0.4		0.6		0.8		1.0	
	RPM	BHP	RPM	BHP	RPM	BHP	RPM	BHP	RPM	BHP
3000	616	0.79	689	0.97	757	1.16	821	1.36	882	1.57
3250	655	0.96	724	1.16	788	1.37	849	1.58	907	1.80
3500	695	1.17	760	1.38	821	1.60	879	1.83	934	2.06
3750	736	1.41	797	1.63	855	1.86	910	2.10	963	2.35
4000	777	1.68	834	1.91	889	2.16	942	2.41	993	2.67
4250	818	1.98	873	2.23	925	2.49	976	2.75	1025	3.02
4500	860	2.32	912	2.58	962	2.85	1010	3.13	1057	3.41
4750	902	2.69	951	2.97	999	3.26	1046	3.55	1091	3.84
5000	944	3.11	991	3.40	1037	3.70	1082	4.00	1125	4.31

CFM	Available External Static Pressure (in. wg)									
	1.2		1.4		1.6		1.8		2.0	
	RPM	BHP	RPM	BHP	RPM	BHP	RPM	BHP	RPM	BHP
3000	939	1.79	994	2.01	1047	2.24	1098	2.47	1147	2.71
3250	962	2.03	1015	2.26	1066	2.50	1115	2.75	1163	3.00
3500	987	2.30	1038	2.54	1088	2.80	1135	3.05	1181	3.32
3750	1014	2.60	1063	2.86	1111	3.12	1157	3.39	1202	3.66
4000	1042	2.93	1090	3.20	1136	3.48	1180	3.76	1224	4.04
4250	1072	3.30	1118	3.58	1162	3.87	1205	4.16	<b>1247</b>	<b>4.46</b>
4500	1103	3.70	1147	4.00	1190	4.29	1232	4.60	-	-
4750	1135	4.14	1177	4.45	-	-	-	-	-	-
5000	1167	4.63	-	-	-	-	-	-	-	-

**NOTE:** For more information, see General Fan Performance Notes.  
**Boldface** indicates field-supplied drive is required.

Standard static 591 – 838 RPM, 2.4 BHP max  
 Medium static 838 – 1084 RPM, 3.7 BHP max  
 High static 1022 – 1240 RPM, 4.9 BHP max

**Table 54 – RGH120**

**3 PHASE**

**10 TON HORIZONTAL SUPPLY**

CFM	Available External Static Pressure (in. wg)									
	0.2		0.4		0.6		0.8		1.0	
	RPM	BHP	RPM	BHP	RPM	BHP	RPM	BHP	RPM	BHP
3000	579	0.70	660	0.89	732	1.09	799	1.29	860	1.50
3250	613	0.85	690	1.06	760	1.27	823	1.49	883	1.71
3500	648	1.03	721	1.25	788	1.48	850	1.71	907	1.95
3750	683	1.23	753	1.47	817	1.71	877	1.96	933	2.21
4000	719	1.45	786	1.71	848	1.97	905	2.23	959	2.50
4250	756	1.71	819	1.98	879	2.26	934	2.53	987	2.81
4500	792	1.99	853	2.28	910	2.57	964	2.87	1015	3.16
4750	830	2.31	888	2.62	943	2.92	995	3.23	1044	3.54
5000	867	2.66	923	2.98	976	3.30	1026	3.63	1074	3.95

CFM	Available External Static Pressure (in. wg)									
	1.2		1.4		1.6		1.8		2.0	
	RPM	BHP	RPM	BHP	RPM	BHP	RPM	BHP	RPM	BHP
3000	917	1.70	970	1.91	1021	2.13	1070	2.34	1117	2.56
3250	938	1.93	991	2.16	1041	2.38	1089	2.61	1134	2.85
3500	961	2.18	1013	2.42	1062	2.66	1108	2.91	1153	3.15
3750	985	2.46	1035	2.71	1083	2.97	1129	3.23	1173	3.49
4000	1011	2.76	1059	3.03	1106	3.30	1151	3.58	1194	3.85
4250	1037	3.09	1084	3.38	1130	3.66	1174	3.95	1216	4.24
4500	1064	3.46	1110	3.76	1155	4.06	1198	4.36	1239	4.66
4750	1091	3.85	1137	4.16	1180	4.48	-	-	-	-
5000	1120	4.28	1164	4.61	-	-	-	-	-	-

**NOTE:** For more information, see General Fan Performance Notes.

Standard static 591 – 838 RPM, 2.4 BHP max  
 Medium static 838 – 1084 RPM, 3.7 BHP max  
 High static 1022 – 1240 RPM, 4.9 BHP max

# FAN PERFORMANCE (BELT DRIVE) cont

**Table 55 – RGH150**

**3 PHASE**

**12.5 TON VERTICAL SUPPLY**

CFM	Available External Static Pressure (in. wg)									
	0.2		0.4		0.6		0.8		1.0	
	RPM	BHP	RPM	BHP	RPM	BHP	RPM	BHP	RPM	BHP
3438	431	0.59	504	0.81	574	1.08	643	1.40	706	1.74
3750	456	0.71	524	0.95	589	1.22	653	1.54	715	1.90
4063	481	0.86	546	1.11	606	1.39	666	1.71	725	2.07
4375	507	1.03	569	1.30	626	1.59	681	1.91	736	2.27
4688	533	1.22	593	1.51	647	1.81	698	2.13	750	2.49
5000	560	1.44	617	1.74	669	2.05	718	2.39	766	2.75
5313	587	1.68	642	2.00	691	2.33	738	2.67	784	3.04
5625	614	1.95	667	2.29	715	2.63	760	2.99	804	3.36
5938	642	2.25	692	2.60	739	2.97	782	3.34	824	3.72
6250	670	2.58	718	2.95	763	3.33	805	3.72	846	4.11

CFM	Available External Static Pressure (in. wg)									
	1.2		1.4		1.6		1.8		2.0	
	RPM	BHP	RPM	BHP	RPM	BHP	RPM	BHP	RPM	BHP
3438	763	2.10	815	2.46	862	2.82	905	3.18	946	3.55
3750	772	2.28	825	2.66	873	3.05	918	3.45	<b>959</b>	<b>3.84</b>
4063	781	2.46	834	2.87	883	3.29	929	3.71	<b>971</b>	<b>4.14</b>
4375	790	2.66	843	3.09	892	3.53	938	3.98	<b>982</b>	<b>4.43</b>
4688	801	2.89	852	3.32	901	3.78	947	4.25	<b>991</b>	<b>4.73</b>
5000	814	3.15	863	3.58	910	4.04	<b>956</b>	<b>4.53</b>	<b>999</b>	<b>5.03</b>
5313	830	3.44	875	3.87	920	4.33	<b>965</b>	<b>4.83</b>	<b>1008</b>	<b>5.34</b>
5625	847	3.77	890	4.20	933	4.66	<b>975</b>	<b>5.15</b>	<b>1017</b>	<b>5.67</b>
5938	865	4.13	906	4.56	947	5.03	<b>987</b>	<b>5.52</b>	<b>1028</b>	<b>6.04</b>
6250	885	4.53	924	4.97	962	5.43	<b>1001</b>	<b>5.92</b>	-	-

**NOTE:** For more information, see General Fan Performance Notes.  
**Boldface** indicates field-supplied drive is required.

Standard static 440 – 609 RPM, 2.9 BHP max  
 Medium static 609 – 778 RPM, 3.7 BHP max  
 High static 776 – 955 RPM, 6.1 BHP max

**Table 56 – RGH150**

**3 PHASE**

**12.5 TON HORIZONTAL SUPPLY**

CFM	Available External Static Pressure (in. wg)									
	0.2		0.4		0.6		0.8		1.0	
	RPM	BHP	RPM	BHP	RPM	BHP	RPM	BHP	RPM	BHP
3438	421	0.57	493	0.78	561	1.02	627	1.30	688	1.62
3750	445	0.69	512	0.91	576	1.17	638	1.45	697	1.77
4063	470	0.84	533	1.07	593	1.33	651	1.62	707	1.94
4375	496	1.00	555	1.25	612	1.52	666	1.82	720	2.14
4688	522	1.19	579	1.46	632	1.74	683	2.04	734	2.37
5000	549	1.41	602	1.68	653	1.98	702	2.29	750	2.62
5313	576	1.64	627	1.94	675	2.24	721	2.57	767	2.91
5625	603	1.91	652	2.22	698	2.54	742	2.87	786	3.23
5938	630	2.20	677	2.53	721	2.87	764	3.21	805	3.57
6250	657	2.53	702	2.87	745	3.22	786	3.58	826	3.96

CFM	Available External Static Pressure (in. wg)									
	1.2		1.4		1.6		1.8		2.0	
	RPM	BHP	RPM	BHP	RPM	BHP	RPM	BHP	RPM	BHP
3438	746	1.96	799	2.32	849	2.70	896	3.09	940	3.50
3750	753	2.12	806	2.48	856	2.88	903	3.28	947	3.70
4063	761	2.29	813	2.67	862	3.07	909	3.48	953	3.92
4375	771	2.50	821	2.88	869	3.28	916	3.70	<b>960</b>	<b>4.15</b>
4688	783	2.73	831	3.11	878	3.52	923	3.95	<b>966</b>	<b>4.40</b>
5000	797	2.99	843	3.37	888	3.78	931	4.22	<b>974</b>	<b>4.67</b>
5313	812	3.28	856	3.67	899	4.08	941	4.52	<b>983</b>	<b>4.98</b>
5625	828	3.60	870	3.99	912	4.41	953	4.85	<b>993</b>	<b>5.31</b>
5938	846	3.95	886	4.36	926	4.78	<b>965</b>	<b>5.22</b>	<b>1004</b>	<b>5.69</b>
6250	865	4.35	904	4.75	942	5.18	<b>979</b>	<b>5.63</b>	-	-

**NOTE:** For more information, see General Fan Performance Notes.  
**Boldface** indicates field-supplied drive is required.

Standard static 440 – 609 RPM, 2.9 BHP max  
 Medium static 609 – 778 RPM, 3.7 BHP max  
 High static 776 – 955 RPM, 6.1 BHP max

## FAN PERFORMANCE (cont)

### X13 multi-speed/torque motor

**Table 57 – RGH036 Vertical Unit-Direct Drive**

Speed (Torque) Tap	CFM	ESP	BHP
1	900	0.30	0.19
	975	0.17	0.17
	1050	0.06	0.16
	1125	-	-
	1200	-	-
	1275	-	-
	1350	-	-
	1425	-	-
	1500	-	-
2	900	0.48	0.25
	975	0.34	0.23
	1050	0.20	0.22
	1125	0.07	0.20
	1200	-	-
	1275	-	-
	1350	-	-
	1425	-	-
	1500	-	-
3	900	0.84	0.38
	975	0.69	0.36
	1050	0.53	0.33
	1125	0.38	0.32
	1200	0.24	0.31
	1275	0.10	0.31
	1350	-	-
	1425	-	-
	1500	-	-
4	900	0.99	0.43
	975	0.88	0.43
	1050	0.75	0.43
	1125	0.61	0.43
	1200	0.47	0.42
	1275	0.33	0.40
	1350	0.19	0.38
	1425	-	-
	1500	-	-
5	900	1.10	0.47
	975	1.02	0.49
	1050	0.75	0.51
	1125	0.61	0.54
	1200	0.81	0.56
	1275	0.74	0.58
	1350	0.67	0.61
	1425	0.60	0.63
	1500	0.52	0.66

**Table 58 – RGH036 Horizontal Unit-Direct Drive**

Speed (Torque) Tap	CFM	ESP	BHP
1	900	0.45	0.23
	975	0.33	0.22
	1050	0.22	0.20
	1125	0.12	0.19
	1200	0.05	0.17
	1275	-	-
	1350	-	-
	1425	-	-
	1500	-	-
2	900	0.66	0.30
	975	0.52	0.28
	1050	0.39	0.27
	1125	0.27	0.26
	1200	0.16	0.24
	1275	0.05	0.23
	1350	-	-
	1425	-	-
	1500	-	-
3	900	1.01	0.43
	975	0.88	0.41
	1050	0.73	0.39
	1125	0.59	0.38
	1200	0.46	0.36
	1275	0.33	0.36
	1350	0.21	0.33
	1425	0.09	0.31
	1500	-	-
4	900	1.13	0.46
	975	1.03	0.46
	1050	0.92	0.46
	1125	0.81	0.46
	1200	0.69	0.46
	1275	0.57	0.45
	1350	0.44	0.44
	1425	0.31	0.42
	1500	0.18	0.40
5	900	1.20	0.49
	975	1.14	0.51
	1050	0.92	0.53
	1125	0.81	0.55
	1200	0.95	0.57
	1275	0.90	0.60
	1350	0.84	0.62
	1425	0.78	0.65
	1500	0.72	0.68

## FAN PERFORMANCE (cont)

### X13 multi-speed/torque motor (cont)

**Table 59 – RGH048 Vertical Unit-Direct Drive**

Speed (Torque) Tap	CFM	ESP	BHP
1	1200	0.38	0.30
	1300	0.24	0.28
	1400	0.12	0.27
	1500	0.01	0.26
	1600	-	-
	1700	-	-
	1800	-	-
	1900	-	-
	2000	-	-
2	1200	0.49	0.34
	1300	0.34	0.32
	1400	0.20	0.31
	1500	0.05	0.29
	1600	-	-
	1700	-	-
	1800	-	-
	1900	-	-
	2000	-	-
3	1200	0.87	0.56
	1300	0.74	0.57
	1400	0.60	0.59
	1500	0.44	0.56
	1600	0.29	0.50
	1700	0.14	0.47
	1800	0.02	0.46
	1900	-	-
	2000	-	-
4	1200	0.93	0.57
	1300	0.83	0.60
	1400	0.72	0.63
	1500	0.60	0.63
	1600	0.48	0.62
	1700	0.35	0.62
	1800	0.21	0.61
	1900	0.06	0.58
	2000	-	-
5	1200	0.97	0.58
	1300	0.89	0.61
	1400	0.72	0.65
	1500	0.60	0.68
	1600	0.64	0.72
	1700	0.55	0.75
	1800	0.46	0.79
	1900	0.35	0.82
	2000	0.25	0.86

**Table 60 – RGH048 Horizontal Unit-Direct Drive**

Speed (Torque) Tap	CFM	ESP	BHP
1	1200	0.49	0.35
	1300	0.34	0.33
	1400	0.20	0.31
	1500	0.06	0.29
	1600	-	-
	1700	-	-
	1800	-	-
	1900	-	-
	2000	-	-
2	1200	0.60	0.40
	1300	0.45	0.38
	1400	0.30	0.36
	1500	0.16	0.34
	1600	0.01	0.32
	1700	-	-
	1800	-	-
	1900	-	-
	2000	-	-
3	1200	0.94	0.59
	1300	0.83	0.61
	1400	0.71	0.63
	1500	0.59	0.61
	1600	0.46	0.59
	1700	0.33	0.56
	1800	0.19	0.53
	1900	0.07	0.49
	2000	-	-
4	1200	0.98	0.59
	1300	0.89	0.62
	1400	0.81	0.65
	1500	0.72	0.66
	1600	0.62	0.67
	1700	0.52	0.68
	1800	0.40	0.68
	1900	0.27	0.66
	2000	0.12	0.61
5	1200	1.02	0.60
	1300	0.95	0.63
	1400	0.81	0.67
	1500	0.72	0.70
	1600	0.74	0.74
	1700	0.67	0.78
	1800	0.59	0.82
	1900	0.51	0.86
	2000	0.42	0.89

## FAN PERFORMANCE (cont)

### X13 multi-speed/torque motor (cont)

**Table 61 – RGH060 Vertical Unit-Direct Drive**

Speed (Torque) Tap	CFM	ESP	BHP
1	1500	0.27	0.45
	1625	0.08	0.43
	1750	-	-
	1875	-	-
	2000	-	-
	2125	-	-
	2250	-	-
	2375	-	-
	2500	-	-
2	1500	0.48	0.57
	1625	0.26	0.55
	1750	0.08	0.53
	1875	-	-
	2000	-	-
	2125	-	-
	2250	-	-
	2375	-	-
	2500	-	-
3	1500	0.91	0.82
	1625	0.72	0.82
	1750	0.52	0.81
	1875	0.31	0.78
	2000	0.11	0.77
	2125	-	-
	2250	-	-
	2375	-	-
	2500	-	-
4	1500	0.98	0.85
	1625	0.82	0.89
	1750	0.66	0.92
	1875	0.50	0.90
	2000	0.32	0.92
	2125	0.13	0.86
	2250	-	-
	2375	-	-
	2500	-	-
5	1500	1.00	-
	1625	0.86	0.91
	1750	0.66	0.95
	1875	0.50	0.98
	2000	0.41	1.01
	2125	0.25	0.88
	2250	0.06	1.01
	2375	-	-
	2500	-	-

**Table 62 – RGH060 Horizontal Unit-Direct Drive**

Speed (Torque) Tap	CFM	ESP	BHP
1	1500	0.40	0.50
	1625	0.20	0.48
	1750	0.04	0.45
	1875	-	-
	2000	-	-
	2125	-	-
	2250	-	-
	2375	-	-
	2500	-	-
	2	1500	0.62
1625		0.39	0.60
1750		0.19	0.57
1875		0.03	0.53
2000		-	-
2125		-	-
2250		-	-
2375		-	-
2500		-	-
3		1500	1.04
	1625	0.87	0.88
	1750	0.68	0.88
	1875	0.48	0.84
	2000	0.28	0.84
	2125	0.07	0.84
	2250	-	-
	2375	-	-
	2500	-	-
	4	1500	1.10
1625		0.96	0.94
1750		0.81	0.98
1875		0.65	0.95
2000		0.47	1.00
2125		0.27	0.94
2250		0.05	0.96
2375		-	-
2500		-	-
5		1500	1.12
	1625	1.00	0.96
	1750	0.81	1.00
	1875	0.65	1.04
	2000	0.56	1.08
	2125	0.39	0.95
	2250	0.19	1.09
	2375	-	-
	2500	-	-

## FAN PERFORMANCE (cont)

**Table 63 – PULLEY ADJUSTMENT**

RGH UNIT		Motor/Drive Combo	Motor Pulley turns open										
			0	0.5	1	1.5	2	2.5	3	3.5	4	4.5	5
036	1 Phase	Standard Static	854	825	795	766	736	707	678	648	619	589	560
		Medium Static	1175	1135	1094	1054	1013	973	932	892	851	811	770
	3 Phase	Standard Static*	854	825	795	766	736	707	678	648	619	589	560
		Medium Static*	1175	1135	1094	1054	1013	973	932	892	851	811	770
		High Static	1466	1423	1380	1337	1294	1251	1207	1164	1121	1078	1035
		High Static	1466	1423	1380	1337	1294	1251	1207	1164	1121	1078	1035
048	1 Phase	Standard Static	854	825	795	766	736	707	678	648	619	589	560
		Medium Static	1175	1135	1094	1054	1013	973	932	892	851	811	770
	3 Phase	Standard Static*	854	825	795	766	736	707	678	648	619	589	560
		Medium Static*	1175	1135	1094	1054	1013	973	932	892	851	811	770
		Medium Static	1303	1265	1226	1188	1150	1112	1073	1035	997	958	920
		High Static	1639	1596	1553	1510	1467	1424	1380	1337	1294	1251	1208
060	1 Phase	Standard Static	1175	1135	1094	1054	1013	973	932	892	851	811	770
		Medium Static	1466	1423	1380	1337	1294	1251	1207	1164	1121	1078	1035
	3 Phase	Standard Static*	1175	1135	1094	1054	1013	973	932	892	851	811	770
		Medium Static*	1466	1423	1380	1337	1294	1251	1207	1164	1121	1078	1035
		High Static	1687	1649	1610	1572	1533	1495	1457	1418	1380	1341	1303
		High Static	1687	1649	1610	1572	1533	1495	1457	1418	1380	1341	1303
072 073	3 Phase	Standard Static	747	721	695	670	644	618	592	566	541	515	489
		Medium Static	949	927	906	884	863	841	819	798	776	755	733
		High Static	1102	1083	1063	1044	1025	1006	986	967	948	928	909
090	3 Phase	Standard Static	733	712	690	669	647	626	604	583	561	540	518
		Medium Static	936	911	887	862	838	813	788	764	739	715	690
		High Static	1084	1059	1035	1010	986	961	936	912	887	863	838
102	3 Phase	Standard Static	733	712	690	669	647	626	604	583	561	540	518
		Medium Static	936	911	887	862	838	813	788	764	739	715	690
		High Static	1084	1059	1035	1010	986	961	936	912	887	863	838
110	3 Phase	Standard Static	838	813	789	764	739	715	690	665	640	616	591
		Medium Static	1084	1059	1035	1010	986	961	936	912	887	863	838
		High Static	1240	1218	1196	1175	1153	1131	1109	1087	1066	1044	1022
120	3 Phase	Standard Static	838	813	789	764	739	715	690	665	640	616	591
		Medium Static	1084	1059	1035	1010	986	961	936	912	887	863	838
		High Static	1240	1218	1196	1175	1153	1131	1109	1087	1066	1044	1022
150	3 Phase	Standard Static	609	592	575	558	541	525	508	491	474	457	440
		Medium Static	778	761	744	727	710	694	677	660	643	626	609
		High Static	955	973	951	929	907	886	864	842	820	798	776

■ - Factory settings

\* Hot Gas Re-Heat models only

# ELECTRICAL INFORMATION

**Table 64 – RGH036**
**SINGLE STAGE COOLING WITH SINGLE SPEED INDOOR FAN MOTOR**

V-Ph-Hz	VOLTAGE RANGE		COMP (ea)		OFM (ea)		IFM		
	MIN	MAX	RLA	LRA	WATTS	FLA	TYPE	EFF at Full Load	FLA
208-1-60	187	253	16.6	79	190	1.0	DD-STD	78%	7.4
					190	1.0	STD	67%	4.9
					190	1.0	MED	67%	4.9
230-1-60	187	253	16.6	79	190	1.0	DD-STD	78%	7.4
					190	1.0	STD	67%	4.9
					190	1.0	MED	67%	4.9
208-3-60	187	253	10.4	73	190	1.0	DD-STD	78%	7.4
					190	1.0	STD	75%	5.2
					190	1.0	MED	87%	5.2
230-3-60	187	253	10.4	73	190	1.0	HIGH	89%	8.4
					190	1.0	DD-STD	78%	7.4
					190	1.0	STD	75%	5.2
460-3-60	414	506	5.8	38	190	1.0	MED	87%	4.9
					190	1.0	HIGH	89%	8.3
					190	0.5	DD-STD	78%	4.0
575-3-60	518	633	3.8	37	190	0.5	STD	75%	2.6
					190	0.5	MED	87%	2.5
					190	0.5	HIGH	89%	4.2
208-3-60	187	253	13.7	83	190	0.5	DD-STD	78%	4.0
					190	0.5	STD	73%	1.2
					190	0.5	MED	73%	1.2
460-3-60	414	506	6.2	41	190	0.5	HIGH	78%	2.0
					325	1.4	DD-STD	78%	7.4
					325	1.4	STD	67%	4.9
575-3-60	518	633	4.8	33	325	1.4	MED	67%	4.9
					325	1.4	DD-STD	78%	7.4
					325	1.4	STD	67%	4.9
208-1-60	187	253	21.8	117	325	1.4	DD-STD	78%	7.4
					325	1.4	STD	67%	4.9
					325	1.4	MED	67%	4.9
230-1-60	187	253	21.8	117	325	1.4	DD-STD	78%	7.4
					325	1.4	STD	67%	4.9
					325	1.4	MED	67%	4.9
208-3-60	187	253	13.7	83	325	1.4	DD-STD	78%	7.4
					325	1.4	STD	75%	5.2
					325	1.4	MED	87%	5.2
230-3-60	187	253	13.7	83	325	1.4	HIGH	89%	8.4
					325	1.4	DD-STD	78%	7.4
					325	1.4	STD	75%	5.2
460-3-60	414	506	6.2	41	325	1.4	MED	87%	4.9
					325	1.4	HIGH	89%	8.3
					325	0.9	DD-STD	78%	4.0
575-3-60	518	633	4.8	33	325	0.9	STD	75%	2.6
					325	0.9	MED	87%	2.5
					325	0.9	HIGH	89%	4.2
208-1-60	187	253	21.8	117	325	0.9	DD-STD	78%	4.0
					325	0.9	STD	73%	1.2
					325	0.9	MED	72%	1.6
230-1-60	187	253	21.8	117	325	0.9	HIGH	77%	2.8
					325	0.9	DD-STD	78%	7.4
					325	0.9	STD	67%	4.9

**Table 65 – RGH048**
**SINGLE STAGE COOLING WITH SINGLE SPEED INDOOR FAN MOTOR**

V-Ph-Hz	VOLTAGE RANGE		COMP (ea)		OFM (ea)		IFM		
	MIN	MAX	RLA	LRA	WATTS	FLA	TYPE	EFF at Full Load	FLA
208-1-60	187	253	21.8	117	325	1.4	DD-STD	78%	7.4
					325	1.4	STD	67%	4.9
					325	1.4	MED	67%	4.9
230-1-60	187	253	21.8	117	325	1.4	DD-STD	78%	7.4
					325	1.4	STD	67%	4.9
					325	1.4	MED	67%	4.9
208-3-60	187	253	13.7	83	325	1.4	DD-STD	78%	7.4
					325	1.4	STD	75%	5.2
					325	1.4	MED	87%	5.2
230-3-60	187	253	13.7	83	325	1.4	HIGH	89%	8.4
					325	1.4	DD-STD	78%	7.4
					325	1.4	STD	75%	5.2
460-3-60	414	506	6.2	41	325	1.4	MED	87%	4.9
					325	1.4	HIGH	89%	8.3
					325	0.9	DD-STD	78%	4.0
575-3-60	518	633	4.8	33	325	0.9	STD	75%	2.6
					325	0.9	MED	87%	2.5
					325	0.9	HIGH	89%	4.2
208-1-60	187	253	21.8	117	325	0.9	DD-STD	78%	4.0
					325	0.9	STD	73%	1.2
					325	0.9	MED	72%	1.6
230-1-60	187	253	21.8	117	325	0.9	HIGH	77%	2.8
					325	0.9	DD-STD	78%	7.4
					325	0.9	STD	67%	4.9

# ELECTRICAL INFORMATION (cont)

**Table 66 – RGH060**
**SINGLE STAGE COOLING WITH SINGLE SPEED INDOOR FAN MOTOR**

V-Ph-Hz	VOLTAGE RANGE		COMP (ea)		OFM (ea)		IFM		
	MIN	MAX	RLA	LRA	WATTS	FLA	TYPE	EFF at Full Load	FLA
208-1-60	187	253	25.0	134	325	1.4	DD-STD	78%	7.4
					325	1.4	STD	67%	4.9
					325	1.4	MED	76%	7.0
230-1-60	187	253	25.0	134	325	1.4	DD-STD	78%	7.4
					325	1.4	STD	67%	4.9
					325	1.4	MED	76%	7.0
208-3-60	187	253	15.9	110	325	1.4	DD-STD	78%	7.4
					325	1.4	STD	75%	5.2
					325	1.4	MED	87%	6.9
230-3-60	187	253	15.9	110	325	1.4	DD-STD	78%	7.4
					325	1.4	STD	75%	5.2
					325	1.4	MED	89%	8.3
460-3-60	414	506	7.0	52	325	1.4	HIGH	89%	8.3
					325	0.9	DD-STD	78%	4.0
					325	0.9	STD	75%	2.6
575-3-60	518	633	5.1	40	325	0.9	MED	89%	4.2
					325	0.9	HIGH	89%	4.2
					325	0.9	DD-STD	78%	4.0
575-3-60	518	633	5.1	40	325	0.9	STD	73%	1.2
					325	0.9	MED	78%	2.0
					325	0.9	HIGH	77%	2.8

**Table 67 – RGH072**
**SINGLE STAGE COOLING WITH SINGLE SPEED INDOOR FAN MOTOR**

V-Ph-Hz	VOLTAGE RANGE		COMP (ea)		OFM (ea)		IFM		
	MIN	MAX	RLA	LRA	WATTS	FLA	TYPE	EFF at Full Load	FLA
208-3-60	187	253	19.6	136	325	1.5	STD	75%	5.2
					325	1.5	MED	89%	8.4
					325	1.5	HIGH	83%	13.6
230-3-60	187	253	19.6	136	325	1.5	STD	75%	5.2
					325	1.5	MED	89%	8.3
					325	1.5	HIGH	83%	12.7
460-3-60	414	506	8.2	66	325	0.8	STD	75%	2.6
					325	0.8	MED	89%	4.2
					325	0.8	HIGH	83%	6.4
575-3-60	518	633	6.6	55	325	0.6	STD	72%	1.6
					325	0.6	MED	77%	2.8
					325	0.6	HIGH	81%	5.6

**Table 68 – RGH073**
**2-STAGE COOLING WITH SINGLE SPEED INDOOR FAN MOTOR**

V-Ph-Hz	VOLTAGE RANGE		COMP (ea)		OFM (ea)		IFM		
	MIN	MAX	RLA	LRA	WATTS	FLA	TYPE	EFF at Full Load	FLA
208-3-60	187	253	17.5	136	325	1.5	STD	75%	5.2
					325	1.5	MED	89%	8.4
					325	1.5	HIGH	83%	13.6
230-3-60	187	253	17.5	136	325	1.5	STD	75%	5.2
					325	1.5	MED	89%	8.3
					325	1.5	HIGH	83%	12.7
460-3-60	414	506	8.4	66	325	0.8	STD	75%	2.6
					325	0.8	MED	89%	4.2
					325	0.8	HIGH	83%	6.4
575-3-60	518	633	6.3	55	325	0.6	STD	72%	1.6
					325	0.6	MED	77%	2.8
					325	0.6	HIGH	81%	5.6

# ELECTRICAL INFORMATION (cont)

**Table 69 – RGH090**

**2-STAGE COOLING WITH SINGLE SPEED INDOOR FAN MOTOR**

V-Ph-Hz	VOLTAGE RANGE		COMP (Cir 1)		COMP (Cir 2)		OFM (ea)		IFM		
	MIN	MAX	RLA	LRA	RLA	LRA	WATTS	FLA	TYPE	EFF at Full Load	FLA
208-3-60	187	253	13.6	83	13.6	83	325	1.5	STD	75%	5.2
							325	1.5	MED	87%	6.9
							325	1.5	HIGH	87%	10.6
230-3-60	187	253	13.6	83	13.6	83	325	1.5	STD	75%	5.2
							325	1.5	MED	87%	6.7
							325	1.5	HIGH	87%	10.6
460-3-60	414	506	6.1	41	6.1	41	325	0.8	STD	75%	2.6
							325	0.8	MED	87%	3.4
							325	0.8	HIGH	87%	5.3
575-3-60	518	633	4.2	33	4.2	33	325	0.6	STD	72%	1.6
							325	0.6	MED	78%	2
							325	0.6	HIGH	77%	2.8

**Table 70 – RGH102**

**2-STAGE COOLING WITH SINGLE SPEED INDOOR FAN MOTOR**

V-Ph-Hz	VOLTAGE RANGE		COMP (Cir 1)		COMP (Cir 2)		OFM (ea)		IFM		
	MIN	MAX	RLA	LRA	RLA	LRA	WATTS	FLA	TYPE	EFF at Full Load	FLA
208-3-60	187	253	13.7	83	13.7	83	325	1.5	STD	75%	5.2
							325	1.5	MED	87%	6.9
							325	1.5	HIGH	87%	10.6
230-3-60	187	253	13.7	83	13.7	83	325	1.5	STD	75%	5.2
							325	1.5	MED	87%	6.7
							325	1.5	HIGH	87%	10.6
460-3-60	414	506	6.2	41	6.2	41	325	0.8	STD	75%	2.6
							325	0.8	MED	87%	3.4
							325	0.8	HIGH	87%	5.3
575-3-60	518	633	4.8	33	4.8	33	325	0.6	STD	72%	1.6
							325	0.6	MED	78%	2
							325	0.6	HIGH	77%	2.8

**Table 71 – RGH110**

**2-STAGE COOLING WITH SINGLE SPEED INDOOR FAN MOTOR**

V-Ph-Hz	VOLTAGE RANGE		COMP (Cir 1)		COMP (Cir 2)		OFM (ea)		IFM		
	MIN	MAX	RLA	LRA	RLA	LRA	WATTS	FLA	TYPE	EFF at Full Load	FLA
208-3-60	187	253	15.9	110	15.9	110	610	7.4	STD	69%	5.2
							610	7.4	MED	87%	10.6
							610	7.4	HIGH	83%	13.6
230-3-60	187	253	15.9	110	15.9	110	610	7.4	STD	69%	2.6
							610	7.4	MED	87%	10.6
							610	7.4	HIGH	83%	12.7
460-3-60	414	506	7.0	52	7.0	52	610	3.6	STD	69%	2.6
							610	3.6	MED	87%	5.3
							610	3.6	HIGH	83%	6.4
575-3-60	518	633	5.1	40	5.1	40	610	3.6	STD	78%	2
							610	3.6	MED	77%	2.8
							610	3.6	HIGH	81%	5.6

## ELECTRICAL INFORMATION (cont)

**Table 72 – RGH120**

**2-STAGE COOLING WITH SINGLE SPEED INDOOR FAN MOTOR**

V-Ph-Hz	VOLTAGE RANGE		COMP (Cir 1)		COMP (Cir 2)		OFM (ea)		IFM		
	MIN	MAX	RLA	LRA	RLA	LRA	WATTS	FLA	TYPE	EFF at Full Load	FLA
208-3-60	187	253	15.9	110	15.9	110	1070	6.2	STD	69%	5.2
							1070	6.2	MED	87%	10.6
							1070	6.2	HIGH	83%	13.6
230-3-60	187	253	15.9	110	15.9	110	1070	6.2	STD	69%	5.2
							1070	6.2	MED	87%	10.6
							1070	6.2	HIGH	83%	12.7
460-3-60	414	506	7.7	52	7.7	52	1070	3.1	STD	69%	2.6
							1070	3.1	MED	87%	5.3
							1070	3.1	HIGH	83%	6.4
575-3-60	518	633	5.7	39	5.7	39	1070	2.5	STD	78%	2
							1070	2.5	MED	77%	2.8
							1070	2.5	HIGH	81%	5.6

**Table 73 – RGH150**

**2-STAGE COOLING WITH SINGLE SPEED INDOOR FAN MOTOR**

V-Ph-Hz	VOLTAGE RANGE		COMP (Cir 1)		COMP (Cir 2)		OFM (ea)		IFM		
	MIN	MAX	RLA	LRA	RLA	LRA	WATTS	FLA	TYPE	EFF at Full Load	FLA
208-3-60	187	253	19.6	136	19.6	136	280	1.5	STD	79%	7.5
							280	1.5	MED	87%	10.6
							280	1.5	HIGH	90%	20.4
230-3-60	187	253	19.6	136	19.6	136	280	1.5	STD	79%	7.5
							280	1.5	MED	87%	10.6
							280	1.5	HIGH	90%	20.4
460-3-60	414	506	8.2	66	8.2	66	280	0.8	STD	79%	3.4
							280	0.8	MED	87%	5.3
							280	0.8	HIGH	90%	10.2
575-3-60	518	633	6.6	55	6.6	55	280	0.7	STD	77%	2.8
							280	0.7	MED	77%	2.8
							280	0.7	HIGH	94%	9.0

## ELECTRICAL INFORMATION (cont)

**Table 74 – RGH073**

**2-STAGE COOLING WITH 2-SPEED INDOOR FAN MOTOR**

V-Ph-Hz	VOLTAGE RANGE		COMP (ea)		OFM (ea)		IFM		
	MIN	MAX	RLA	LRA	WATTS	FLA	TYPE	EFF at Full Load	FLA
208-3-60	187	253	17.5	136	325	1.5	STD	84%	5.8
					325	1.5	MED	85%	8.6
					325	1.5	HIGH	84%	13.6
230-3-60	187	253	17.5	136	325	1.5	STD	84%	5.6
					325	1.5	MED	85%	7.8
					325	1.5	HIGH	84%	12.7
460-3-60	414	506	8.4	66	325	0.8	STD	79%	2.9
					325	0.8	MED	85%	3.8
					325	0.8	HIGH	84%	6.4
575-3-60	518	633	6.3	55	325	0.6	STD	81%	2.8
					325	0.6	MED	84%	4.5
					325	0.6	HIGH	83%	6.2

**Table 75 – RGH090**

**2-STAGE COOLING WITH 2-SPEED INDOOR FAN MOTOR**

V-Ph-Hz	VOLTAGE RANGE		COMP (Cir 1)		COMP (Cir 2)		OFM (ea)		IFM		
	MIN	MAX	RLA	LRA	RLA	LRA	WATTS	FLA	TYPE	EFF at Full Load	FLA
208-3-60	187	253	13.6	83	13.6	83	325	1.5	STD	84%	5.8
							325	1.5	MED	77%	7.1
							325	1.5	HIGH	82%	10.8
230-3-60	187	253	13.6	83	13.6	83	325	1.5	STD	84%	5.6
							325	1.5	MED	77%	6.8
							325	1.5	HIGH	82%	9.8
460-3-60	414	506	6.1	41	6.1	41	325	0.8	STD	79%	2.9
							325	0.8	MED	77%	3.4
							325	0.8	HIGH	82%	4.9
575-3-60	518	633	4.2	33	4.2	33	325	0.6	STD	81%	2.8
							325	0.6	MED	80%	3.5
							325	0.6	HIGH	84%	4.5

**Table 76 – RGH102**

**2-STAGE COOLING WITH 2-SPEED INDOOR FAN MOTOR**

V-Ph-Hz	VOLTAGE RANGE		COMP (Cir 1)		COMP (Cir 2)		OFM (ea)		IFM		
	MIN	MAX	RLA	LRA	RLA	LRA	WATTS	FLA	TYPE	EFF at Full Load	FLA
208-3-60	187	253	13.7	83	13.7	83	325	1.5	STD	84%	5.8
							325	1.5	MED	77%	7.1
							325	1.5	HIGH	82%	10.8
230-3-60	187	253	13.7	83	13.7	83	325	1.5	STD	84%	5.6
							325	1.5	MED	77%	6.8
							325	1.5	HIGH	82%	9.8
460-3-60	414	506	6.2	41	6.2	41	325	0.8	STD	79%	2.9
							325	0.8	MED	77%	3.4
							325	0.8	HIGH	82%	4.9
575-3-60	518	633	4.8	33	4.8	33	325	0.6	STD	81%	2.8
							325	0.6	MED	80%	3.5
							325	0.6	HIGH	84%	4.5

# ELECTRICAL INFORMATION (cont)

**Table 77 – RGH110**

**2-STAGE COOLING WITH 2-SPEED INDOOR FAN MOTOR**

V-Ph-Hz	VOLTAGE RANGE		COMP (Cir 1)		COMP (Cir 2)		OFM (ea)		IFM		
	MIN	MAX	RLA	LRA	RLA	LRA	WATTS	FLA	TYPE	EFF at Full Load	FLA
208-3-60	187	253	15.9	110	15.9	110	610	7.4	STD	77%	7.1
							610	7.4	MED	82%	10.8
							610	7.4	HIGH	84%	13.6
230-3-60	187	253	15.9	110	15.9	110	610	7.4	STD	77%	6.8
							610	7.4	MED	82%	9.8
							610	7.4	HIGH	84%	12.7
460-3-60	414	506	7.0	52	7.0	52	610	3.6	STD	77%	3.4
							610	3.6	MED	82%	4.9
							610	3.6	HIGH	84%	6.4
575-3-60	518	633	5.1	40	5.1	40	610	3.6	STD	80%	3.5
							610	3.6	MED	84%	4.5
							610	3.6	HIGH	83%	6.2

**Table 78 – RGH120**

**2-STAGE COOLING WITH 2-SPEED INDOOR FAN MOTOR**

V-Ph-Hz	VOLTAGE RANGE		COMP (Cir 1)		COMP (Cir 2)		OFM (ea)		IFM		
	MIN	MAX	RLA	LRA	RLA	LRA	WATTS	FLA	TYPE	EFF at Full Load	FLA
208-3-60	187	253	15.9	110	15.9	110	1070	6.2	STD	77%	7.1
							1070	6.2	MED	82%	10.8
							1070	6.2	HIGH	84%	13.6
230-3-60	187	253	15.9	110	15.9	110	1070	6.2	STD	77%	6.8
							1070	6.2	MED	82%	9.8
							1070	6.2	HIGH	84%	12.7
460-3-60	414	506	7.7	52	7.7	52	1070	3.1	STD	77%	3.4
							1070	3.1	MED	82%	4.9
							1070	3.1	HIGH	84%	6.4
575-3-60	518	633	5.7	39	5.7	39	1070	2.5	STD	80%	3.5
							1070	2.5	MED	84%	4.5
							1070	2.5	HIGH	83%	6.2

**Table 79 – RGH150**

**2-STAGE COOLING WITH 2-SPEED INDOOR FAN MOTOR**

V-Ph-Hz	VOLTAGE RANGE		COMP (Cir 1)		COMP (Cir 2)		OFM (ea)		IFM		
	MIN	MAX	RLA	LRA	RLA	LRA	WATTS	FLA	TYPE	EFF at Full Load	FLA
208-3-60	187	253	19.6	136	19.6	136	280	1.5	STD	85%	8.6
							280	1.5	MED	82%	10.8
							280	1.5	HIGH	90%	20.4
230-3-60	187	253	19.6	136	19.6	136	280	1.5	STD	85%	7.8
							280	1.5	MED	82%	9.8
							280	1.5	HIGH	90%	20.4
460-3-60	414	506	8.2	66	8.2	66	280	0.8	STD	85%	3.8
							280	0.8	MED	82%	4.9
							280	0.8	HIGH	90%	10.2
575-3-60	518	633	6.6	55	6.6	55	280	0.7	STD	84%	4.5
							280	0.7	MED	84%	4.5
							280	0.7	HIGH	94%	9

# ELECTRICAL INFORMATION

**Table 80 – UNIT WIRE/FUSE OR HACR BREAKER SIZING DATA WITH SINGLE SPEED INDOOR FAN MOTOR**

UNIT	NOM.V-Ph-Hz	IFM TYPE	NO C.O. or UNPWR C.O.							
			NO P.E.				w/ P.E. (pwrdr fr/ unit)			
			MCA	MAX FUSE or HACR BRKR	DISC. SIZE		MCA	MAX FUSE or HACR BRKR	DISC. SIZE	
FLA	LRA	FLA			LRA					
RGH036 (1-stage cool)	208/230-1-60	DD-STD	30	45	29	88	32	45	31	90
		STD	27	40	26	93	29	45	28	95
		MED	27	40	26	93	29	45	28	95
	208/230-3-60	DD-STD	22	30	22	82	24	30	24	84
		STD	20	25	19	94	22	30	21	96
		MED	20/19	25/25	19/19	111	21/21	30/30	21/21	113
		HIGH	23/23	30/30	23/23	114	25/25	30/30	25/25	149
	460-3-60	DD-STD	12	15	12	43	13	15	13	44
		STD	11	15	10	48	12	15	11	49
		MED	11	15	10	57	12	15	11	58
		HIGH	12	15	11	75	13	15	13	76
	575-3-60	DD-STD	10	15	10	42	12	15	12	44
STD		7	15	6	45	9	15	9	47	
MED		7	15	6	45	9	15	9	47	
HIGH		8	15	7	49	10	15	9	51	
RGH048 (1-stage cool)	208/230-1-60	DD-STD	37	50	35	127	38	50	37	129
		STD	34	50	32	132	36	50	35	134
		MED	34	50	32	132	36	50	35	134
	208/230-3-60	DD-STD	26	30	26	93	28	40	28	95
		STD	24	30	23	105	26	30	26	107
		MED	24/24	30/30	23/23	122	26/26	30/30	26/25	124
		HIGH	27/27	40/40	27/27	158	29/29	40/40	29/29	160
	460-3-60	DD-STD	13	15	13	47	14	20	14	48
		STD	12	15	11	52	13	15	12	53
		MED	12	15	11	61	13	15	12	62
		HIGH	13	15	13	79	14	20	14	80
	575-3-60	DD-STD	11	15	11	39	13	15	13	41
STD		9	15	8	42	10	15	10	44	
MED		9	15	8	42	11	15	11	44	
HIGH		10	15	10	57	12	15	12	59	
RGH060 (1-stage cool)	208/230-1-60	DD-STD	41	60	39	144	42	60	41	146
		STD	38	60	36	149	40	60	38	151
		MED	40	60	38	174	42	60	41	176
	208/230-3-60	DD-STD	29	40	28	120	31	45	31	122
		STD	27	40	26	132	29	40	28	134
		MED	30/30	45/45	30/29	185	32/32	45/45	32/32	187
		HIGH	30/30	45/45	30/29	185	32/32	45/45	32/32	187
	460-3-60	DD-STD	14	20	14	58	15	20	15	59
		STD	13	15	12	63	14	20	13	64
		MED	14	20	14	90	15	20	15	91
		HIGH	14	20	14	90	15	20	15	91
	575-3-60	DD-STD	12	15	12	46	14	15	14	48
STD		9	15	8	49	11	15	10	51	
MED		10	15	9	53	12	15	11	55	
HIGH		11	15	10	64	12	15	12	66	

See Legend and Notes on page 89

# ELECTRICAL INFORMATION

**Table 80 - UNIT WIRE/FUSE OR HACR BREAKER SIZING DATA WITH SINGLE SPEED INDOOR FAN MOTOR (cont)**

UNIT	NOM.V-Ph-Hz	IFM TYPE	W/ PWRD C.O.							
			NO P.E.				w/ P.E. (pwrd fr/ unit)			
			MCA	MAX FUSE or HACR BRKR	DISC. SIZE		MCA	MAX FUSE or HACR BRKR	DISC. SIZE	
					FLA	LRA			FLA	LRA
RGH036 (1-stage cool)	208/230-1-60	DD-STD	-	-	-	-	-	-	-	-
		STD	-	-	-	-	-	-	-	-
		MED	-	-	-	-	-	-	-	-
	208/230-3-60	DD-STD	27	30	27	87	29	35	29	89
		STD	24	30	25	99	26	30	27	101
		MED	24/24	30/30	25/24	116	26/26	30/30	27/26	118
		HIGH	28/28	30/30	28/28	152	30/29	35/35	30/30	154
	460-3-60	DD-STD	14	20	142	45	15	20	16	46
		STD	13	15	13	50	14	20	14	51
		MED	13	15	13	59	14	15	14	60
		HIGH	15	20	15	77	16	20	16	78
	575-3-60	DD-STD	11	15	12	44	13	15	14	46
		STD	9	15	8	47	11	15	10	49
		MED	9	15	8	47	11	15	10	49
		HIGH	9	15	9	51	11	15	11	53
	RGH048 (1-stage cool)	208/230-1-60	DD-STD	-	-	-	-	-	-	-
STD			-	-	-	-	-	-	-	-
MED			-	-	-	-	-	-	-	-
208/230-3-60		DD-STD	31	40	31	98	33	45	34	100
		STD	29	40	29	110	31	40	31	112
		MED	29/29	40/40	29/29	127	31/31	40/40	31/31	129
		HIGH	32/32	45/45	33/32	163	34/34	45/45	35/35	165
460-3-60		DD-STD	15	20	15	49	16	20	16	50
		STD	14	20	14	54	15	20	15	55
		MED	14	15	14	63	15	20	15	64
		HIGH	16	20	16	81	17	20	17	82
575-3-60		DD-STD	13	15	13	41	15	20	15	43
		STD	10	15	10	44	12	15	12	46
		MED	11	15	10	44	13	15	13	46
		HIGH	12	15	12	59	14	15	14	61
RGH060 (1-stage cool)		208/230-1-60	DD-STD	-	-	-	-	-	-	-
	STD		-	-	-	-	-	-	-	
	MED		-	-	-	-	-	-	-	
	208/230-3-60	DD-STD	34	45	34	125	36	50	36	127
		STD	32	45	31	137	34	45	34	139
		MED	35/35	50/50	35/35	190	37/37	50/50	37/37	192
		HIGH	35/35	50/50	35/35	190	37/37	50/50	37/37	192
	460-3-60	DD-STD	16	20	16	60	17	20	17	61
		STD	15	20	15	65	16	20	16	66
		MED	17	20	16	92	18	20	18	93
		HIGH	17	20	16	92	18	20	18	93
	575-3-60	DD-STD	13	15	13	48	15	20	16	50
		STD	11	15	10	51	13	15	12	53
		MED	11	15	11	55	13	15	13	57
		HIGH	12	15	12	65	14	15	14	68

See Legend and Notes on page 89

# ELECTRICAL INFORMATION

**Table 80 - UNIT WIRE/FUSE OR HACR BREAKER SIZING DATA WITH SINGLE SPEED INDOOR FAN MOTOR (cont)**

UNIT	NOM.V-Ph-Hz	IFM TYPE	NO C.O. or UNPWR C.O.							
			NO P.E.				w/ P.E. (pwrd fr/ unit)			
			MCA	MAX FUSE or HACR BRKR	DISC. SIZE		MCA	MAX FUSE or HACR BRKR	DISC. SIZE	
					FLA	LRA			FLA	LRA
RGH072 (1-stage cool)	208/230-3-60	STD	33	50	32	161	37	50	36	165
		MED	36/36	50/50	36/36	214	40/40	50/50	40/40	218
		HIGH	42/41	60/50	42/41	230	45/44	60/60	46/45	234
	460-3-60	STD	15	20	14	79	17	20	16	81
		MED	17	20	16	106	18	25	18	108
		HIGH	19	25	19	114	21	25	21	116
	575-3-60	STD	12	15	11	66	15	20	15	70
		MED	13	15	12	81	17	20	17	85
		HIGH	16	20	15	95	19	25	20	99
RGH073 (2-stage cool)	208/230-3-60	STD	31	45	30	161	34	50	34	165
		MED	34/34	50/50	33/33	214	38/37	50/50	38/37	218
		HIGH	39/38	50/50	39/38	230	43/42	50/50	44/43	234
	460-3-60	STD	15	20	14	79	17	20	17	81
		MED	17	20	16	106	19	25	18	108
		HIGH	19	25	19	114	21	25	21	116
	575-3-60	STD	11	15	10	66	15	20	15	70
		MED	12	15	12	81	16	20	16	85
		HIGH	15	20	15	95	19	25	19	99
RGH090 (2-stage cool)	208/230-3-60	STD	39	50	41	191	43	50	45	195
		MED	41/41	50/50	43/42	229	45/45	50/50	47/47	233
		HIGH	45	50	47	258	48	60	51	262
	460-3-60	STD	18	20	19	95	20	25	21	97
		MED	19	25	20	114	21	25	22	116
		HIGH	21	25	22	129	23	25	24	131
	575-3-60	STD	13	15	13	77	17	20	17	81
		MED	13	15	13	81	17	20	18	85
		HIGH	14	15	14	92	18	20	19	96
RGH102 (2-stage cool)	208/230-3-60	STD	39	50	41	191	43	50	45	195
		MED	41/41	50/50	43/43	229	45/45	50/50	47/47	233
		HIGH	45	50	47	258	49	60	52	262
	460-3-60	STD	19	20	19	95	20	25	21	97
		MED	19	25	20	114	21	25	22	116
		HIGH	21	25	22	129	23	25	24	131
	575-3-60	STD	14	15	14	77	18	20	19	81
		MED	14	20	15	81	18	20	19	85
		HIGH	15	20	16	92	19	20	20	96
RGH110 (2-stage cool)	208/230-3-60	STD	49	60	51	257	53	60	55	261
		MED	54	60	57	313	58	70	62	317
		HIGH	57/56	70/60	61/60	315	61/60	70/70	65/64	319
	460-3-60	STD	22	25	23	123	24	30	25	125
		MED	25	30	26	151	27	30	28	153
		HIGH	26	30	28	152	28	30	30	154
	575-3-60	STD	18	20	18	95	21	25	23	99
		MED	18	20	19	106	22	25	23	110
		HIGH	21	25	22	120	25	30	27	124

See Legend and Notes on page 89

# ELECTRICAL INFORMATION

**Table 80 - UNIT WIRE/FUSE OR HACR BREAKER SIZING DATA WITH SINGLE SPEED INDOOR FAN MOTOR (cont)**

UNIT	NOM.V-Ph-Hz	IFM TYPE	W/ PWRD C.O.							
			NO P.E.				w/ P.E. (pwrd fr/ unit)			
			MCA	MAX FUSE or HACR BRKR	DISC. SIZE		MCA	MAX FUSE or HACR BRKR	DISC. SIZE	
FLA	LRA	FLA			LRA					
RGH072 (1-stage cool)	208/230-3-60	STD	38	50	37	166	42	60	42	170
		MED	41/41	60/60	41/41	219	45/45	60/60	46/45	223
		HIGH	46/45	60/60	47/46	235	50/49	60/60	52/50	239
	460-3-60	STD	17	20	17	81	19	25	19	83
		MED	19	25	19	108	21	25	21	110
		HIGH	21	25	21	116	23	30	23	118
	575-3-60	STD	13	15	13	68	17	20	17	72
		MED	14	20	14	83	18	20	19	87
		HIGH	17	20	17	97	21	25	22	101
RGH073 (2-stage cool)	208/230-3-60	STD	35	50	35	166	39	50	39	170
		MED	39/38	50/50	39/39	219	42/42	50/50	43/43	223
		HIGH	44/43	60/50	45/44	235	48/47	60/60	49/48	239
	460-3-60	STD	17	25	17	81	19	25	19	83
		MED	19	25	19	108	21	25	21	110
		HIGH	21	25	21	116	23	30	23	118
	575-3-60	STD	13	15	12	68	17	20	17	72
		MED	14	20	14	83	18	20	18	87
		HIGH	17	20	17	97	21	25	21	101
RGH090 (2-stage cool)	208/230-3-60	STD	44	50	46	196	48	60	51	200
		MED	46/46	50/50	48/48	234	50/49	60/60	53/52	238
		HIGH	49	60	52	263	53	60	57	267
	460-3-60	STD	21	25	21	97	22	25	23	99
		MED	21	25	22	116	23	25	24	118
		HIGH	23	25	24	131	25	30	27	133
	575-3-60	STD	14	15	15	79	18	20	19	83
		MED	15	20	15	83	19	20	20	87
		HIGH	16	20	16	94	19	25	21	98
RGH102 (2-stage cool)	208/230-3-60	STD	44	50	46	196	48	60	51	200
		MED	46/46	50/50	48/48	234	50/50	60/60	53/53	238
		HIGH	50	60	53	263	53	60	57	267
	460-3-60	STD	21	25	22	97	23	25	24	99
		MED	22	25	23	116	23	25	25	118
		HIGH	24	25	25	131	25	30	27	133
	575-3-60	STD	16	20	16	79	20	25	21	83
		MED	16	20	17	83	20	25	21	87
		HIGH	17	20	18	94	21	25	22	98
RGH110 (2-stage cool)	208/230-3-60	STD	54	60	57	262	57	70	61	266
		MED	59	70	63	318	63	70	67	322
		HIGH	62/61	70/70	66/65	320	66/65	80/80	71/70	324
	460-3-60	STD	25	30	26	125	26	30	28	127
		MED	27	30	29	153	29	35	31	155
		HIGH	28	30	30	154	30	35	32	156
	575-3-60	STD	19	25	20	97	23	25	24	101
		MED	20	25	21	108	24	25	25	112
		HIGH	23	25	24	122	27	30	29	126

See Legend and Notes on page 89

# ELECTRICAL INFORMATION

**Table 80 - UNIT WIRE/FUSE OR HACR BREAKER SIZING DATA WITH SINGLE SPEED INDOOR FAN MOTOR (cont)**

UNIT	NOM.V-Ph-Hz	IFM TYPE	NO C.O. or UNPWR C.O.							
			NO P.E.				w/ P.E. (pwrd fr/ unit)			
			MCA	MAX FUSE or HACR BRKR	DISC. SIZE		MCA	MAX FUSE or HACR BRKR	DISC. SIZE	
FLA	LRA	FLA			LRA					
RGH120 (2-stage cool)	208/230-3-60	STD	48	60	50	282	51	60	54	286
		MED	53	60	56	338	57	70	60	342
		HIGH	56/55	60/60	59/58	340	60/59	70/70	64/63	344
	460-3-60	STD	23	30	24	135	25	30	26	137
		MED	26	30	27	163	28	30	29	165
		HIGH	27	30	29	164	29	35	31	166
	575-3-60	STD	18	20	18	105	22	25	23	109
		MED	19	20	19	116	22	25	24	120
		HIGH	21	25	22	130	25	30	27	134
RGH150 (2-stage cool)	208/230-3-60	STD	57	70	59	340	60	70	63	344
		MED	60	70	62	370	63	80	67	374
		HIGH	70	80	74	376	73	80	78	380
	460-3-60	STD	25	30	26	166	27	30	28	168
		MED	27	30	28	181	28	35	30	183
		HIGH	32	40	33	184	34	40	35	186
	575-3-60	STD	20	25	21	138	24	30	25	142
		MED	20	25	21	138	24	30	25	142
		HIGH	27	30	28	150	31	35	32	154

See Legend and Notes on page 89

**Table 80 - UNIT WIRE/FUSE OR HACR BREAKER SIZING DATA WITH SINGLE SPEED INDOOR FAN MOTOR (cont)**

UNIT	NOM.V-Ph-Hz	IFM TYPE	W/ PWRD C.O.							
			NO P.E.				w/ P.E. (pwrd fr/ unit)			
			MCA	MAX FUSE or HACR BRKR	DISC. SIZE		MCA	MAX FUSE or HACR BRKR	DISC. SIZE	
FLA	LRA	FLA			LRA					
RGH120 (2-stage cool)	208/230-3-60	STD	52	60	55	287	56	60	60	291
		MED	58	70	61	343	62	70	66	347
		HIGH	61/60	70/70	65/64	345	65/64	80/70	69/68	349
	460-3-60	STD	26	30	27	137	27	30	29	139
		MED	28	30	30	165	30	35	32	167
		HIGH	29	35	31	166	31	35	33	168
	575-3-60	STD	19	25	20	107	23	25	25	111
		MED	20	25	21	118	24	30	26	122
		HIGH	23	25	24	132	27	30	29	136
RGH150 (2-stage cool)	208/230-3-60	STD	61	80	64	345	65	80	69	349
		MED	64	80	68	375	68	80	72	379
		HIGH	74	80	79	381	78	80	84	385
	460-3-60	STD	27	30	28	168	29	35	30	170
		MED	29	35	30	183	31	35	32	185
		HIGH	34	40	36	186	36	45	38	188
	575-3-60	STD	22	25	23	140	26	30	27	144
		MED	22	25	23	140	26	30	27	144
		HIGH	29	35	30	152	33	40	34	156

See Legend and Notes on page 89

# ELECTRICAL INFORMATION

**Table 81 – UNIT WIRE SIZING DATA WITH FACTORY INSTALLED 2 SPEED INDOOR FAN OPTION**

UNIT	NOM.V-Ph-Hz	IFM TYPE	NO C.O. or UNPWR C.O.							
			NO P.E.				w/ P.E. (pwrd fr/ unit)			
			MCA	MAX FUSE or HACR BRKR	DISC. SIZE		MCA	MAX FUSE or HACR BRKR	DISC. SIZE	
					FLA	LRA			FLA	LRA
RGH073 (2-stage cool)	208/230-3-60	STD	31/31	45/45	30/30	165	35/35	50/50	35/34	169
		MED	34/33	50/50	33/33	195	38/37	50/50	38/37	199
		HIGH	39/38	50/50	39/38	230	43/42	50/50	44/43	234
	460-3-60	STD	15	20	15	81	17	25	17	83
		MED	16	20	16	97	18	25	18	99
		HIGH	19	25	19	114	21	25	21	116
	575-3-60	STD	12	15	12	68	16	20	16	72
		MED	14	20	14	81	18	20	18	85
		HIGH	16	20	16	95	20	25	20	99
RGH090 (2-stage cool)	208/230-3-60	STD	40/40	50/50	41/41	195	44/43	50/50	46/46	199
		MED	41/41	50/50	43/43	199	45/45	50/50	47/47	203
		HIGH	45/44	50/50	47/46	249	49/48	60/60	52/50	253
	460-3-60	STD	19	20	19	97	20	25	21	99
		MED	19	25	20	100	21	25	22	102
		HIGH	21	25	22	125	22	25	24	127
	575-3-60	STD	14	15	14	79	18	20	19	83
		MED	15	20	15	83	18	20	19	87
		HIGH	16	20	16	92	19	25	21	96
RGH102 (2-stage cool)	208/230-3-60	STD	40/40	50/50	42/41	195	44/44	50/50	46/46	199
		MED	41/41	50/50	43/43	199	45/45	50/50	47/47	203
		HIGH	45/44	50/50	47/46	249	49/48	60/60	52/51	253
	460-3-60	STD	19	25	19	97	21	25	22	99
		MED	19	25	20	100	21	25	22	102
		HIGH	21	25	22	125	23	25	24	127
	575-3-60	STD	15	20	16	79	19	20	20	83
		MED	16	20	16	83	20	25	21	87
		HIGH	17	20	18	92	21	25	22	96
RGH110 (2-stage cool)	208/230-3-60	STD	51/50	60/60	53/53	254	55/54	60/60	58/57	258
		MED	54/53	60/60	58/56	304	58/57	70/70	62/61	308
		HIGH	57/56	70/60	61/60	315	61/60	70/70	65/64	319
	460-3-60	STD	23	25	24	122	25	30	26	124
		MED	25	30	26	147	27	30	28	149
		HIGH	26	30	28	152	28	30	30	154
	575-3-60	STD	19	20	20	97	23	25	24	101
		MED	20	25	21	106	24	25	25	110
		HIGH	22	25	23	120	26	30	27	124
RGH120 (2-stage cool)	208/230-3-60	STD	50/49	60/60	52/52	279	53/53	60/60	56/56	283
		MED	53/52	60/60	56/55	329	57/56	70/60	60/59	333
		HIGH	56/55	60/60	59/58	340	60/59	70/70	64/63	344
	460-3-60	STD	24	30	25	134	26	30	27	136
		MED	26	30	27	159	28	30	29	161
		HIGH	27	30	29	164	29	35	31	166
	575-3-60	STD	19	25	20	107	23	25	24	111
		MED	20	25	21	116	24	30	26	120
		HIGH	22	25	23	130	26	30	27	134

See Legend and Notes on page 89

# ELECTRICAL INFORMATION

**Table 81 - UNIT WIRE SIZING DATA WITH FACTORY INSTALLED 2 SPEED INDOOR FAN OPTION (cont)**

UNIT	NOM.V-Ph-Hz	IFM TYPE	w/ PWRD C.O.							
			NO P.E.				w/ P.E. (pwrd fr/ unit)			
			MCA	MAX FUSE or HACR BRKR	DISC. SIZE		MCA	MAX FUSE or HACR BRKR	DISC. SIZE	
FLA	LRA	FLA			LRA					
RGH073 (2-stage cool)	208/230-3-60	STD	36/36	50/50	36/36	170	40/40	50/50	40/40	174
		MED	39/38	50/50	39/38	200	43/42	50/50	43/42	204
		HIGH	45/44	60/50	45/44	235	48/47	60/60	49/48	239
	460-3-60	STD	18	25	17	83	19	25	19	85
		MED	19	25	18	99	20	25	20	101
		HIGH	21	25	21	116	23	30	23	118
	575-3-60	STD	14	20	14	70	18	20	18	74
		MED	16	20	16	83	20	25	20	87
		HIGH	17	20	18	97	21	25	22	101
RGH090 (2-stage cool)	208/230-3-60	STD	45/44	50/50	47/47	200	48/48	60/60	51/51	204
		MED	46/46	50/50	48/48	204	50/49	60/60	53/52	208
		HIGH	50/49	60/60	53/52	254	53/52	60/60	57/56	258
	460-3-60	STD	21	25	22	99	23	25	24	101
		MED	22	25	23	102	23	25	25	104
		HIGH	23	25	24	127	25	30	26	129
	575-3-60	STD	16	20	16	81	19	25	21	85
		MED	16	20	17	85	20	25	21	89
		HIGH	17	20	18	94	21	25	23	98
RGH102 (2-stage cool)	208/230-3-60	STD	45/45	50/50	47/47	200	49/48	60/60	52/51	204
		MED	46/46	50/50	49/48	204	50/50	60/60	53/53	208
		HIGH	50/49	60/60	53/52	254	54/53	60/60	57/56	258
	460-3-60	STD	21	25	22	99	23	25	24	101
		MED	22	25	23	102	23	25	25	104
		HIGH	23	25	24	127	25	30	26	129
	575-3-60	STD	17	20	18	81	21	25	22	85
		MED	18	20	18	85	21	25	23	89
		HIGH	19	20	20	94	22	25	24	98
RGH110 (2-stage cool)	208/230-3-60	STD	56/55	60/60	59/58	259	59/59	70/70	63/63	263
		MED	59/58	70/70	63/62	309	63/62	70/70	67/66	313
		HIGH	62/61	70/70	66/65	320	66/65	80/80	71/70	324
	460-3-60	STD	25	30	27	124	27	30	29	126
		MED	27	30	28	149	29	35	30	151
		HIGH	28	30	30	154	30	35	32	156
	575-3-60	STD	21	25	22	99	25	30	26	103
		MED	22	25	23	108	26	30	27	112
		HIGH	24	25	25	122	28	30	29	126
RGH120 (2-stage cool)	208/230-3-60	STD	54/54	60/60	57/57	284	58/58	70/70	62/61	288
		MED	58/57	70/70	62/60	334	62/61	70/70	66/65	338
		HIGH	61/60	70/70	65/64	345	65/64	80/70	69/68	349
	460-3-60	STD	26	30	28	136	28	30	30	138
		MED	28	30	29	161	30	35	32	163
		HIGH	29	35	31	166	31	35	33	168
	575-3-60	STD	21	25	22	109	25	30	26	113
		MED	22	25	23	118	26	30	27	122
		HIGH	24	25	25	132	28	30	29	136

See Legend and Notes on page 89

# ELECTRICAL INFORMATION

**Table 81 - UNIT WIRE SIZING DATA WITH FACTORY INSTALLED 2 SPEED INDOOR FAN OPTION (cont)**

UNIT	NOM.V-Ph-Hz	IFM TYPE	NO C.O. or UNPWR C.O.							
			NO P.E.				w/ P.E. (pwrd fr/ unit)			
			MCA	MAX FUSE or HACR BRKR	DISC. SIZE		MCA	MAX FUSE or HACR BRKR	DISC. SIZE	
FLA	LRA	FLA			LRA					
RGH150 (2-stage cool)	208/230-3-60	STD	58/57	70/70	60/59	337	61/61	80/70	65/64	341
		MED	60/59	70/70	63/62	361	64/63	80/80	67/66	365
		HIGH	70	80	74	376	73	80	78	380
	460-3-60	STD	25	30	26	165	27	30	28	167
		MED	26	30	27	177	28	30	29	179
		HIGH	32	40	33	184	34	40	35	186
	575-3-60	STD	22	25	23	138	26	30	27	142
		MED	22	25	23	138	26	30	27	142
		HIGH	27	30	28	150	31	35	32	154

See Legend and Notes on page 89

UNIT	NOM.V-Ph-Hz	IFM TYPE	w/ PWRD C.O.							
			NO P.E.				w/ P.E. (pwrd fr/ unit)			
			MCA	MAX FUSE or HACR BRKR	DISC. SIZE		MCA	MAX FUSE or HACR BRKR	DISC. SIZE	
FLA	LRA	FLA			LRA					
RGH150 (2-stage cool)	208/230-3-60	STD	62/62	80/80	66/65	342	66/65	80/80	70/69	346
		MED	65/64	80/80	68/67	366	68/67	80/80	73/71	370
		HIGH	74	80	79	381	78	90	84	385
	460-3-60	STD	27	30	29	167	29	35	31	169
		MED	28	30	30	179	30	35	32	181
		HIGH	34	40	36	186	36	45	38	188
	575-3-60	STD	24	25	25	140	27	30	29	144
		MED	24	25	25	140	27	30	29	144
		HIGH	29	35	30	152	33	40	34	156

See Legend and Notes on page 89

**Legend and Notes for Tables 80 and 81**

**LEGEND:**

- BRKR – Circuit breaker
- C.O. – Convenience outlet
- DD – Direct drive
- DISC. – Disconnect
- FLA – Full load amps
- IFM – Indoor fan motor
- LRA – Locked rotor amps
- MCA – Minimum circuit amps
- P.E. – Power exhaust
- Pwrd fr/ unit – Powered from unit
- PWRD C.O. – Powered convenience outlet
- UNPWR C.O. – Unpowered convenience outlet

**NOTES:**

1. In compliance with NEC requirements for multimotor and combination load equipment (refer to NEC Articles 430 and 440), the overcurrent protective device for the unit shall be fuse or HACR breaker. Canadian units may be fuse or circuit breaker.
2. For 208/230 v units, where one value is shown it is the same for either 208 or 230 volts.
3. **Unbalanced 3-Phase Supply Voltage**  
Never operate a motor where a phase imbalance in supply voltage is greater than 2%. Use the following formula to determine the percentage of voltage imbalance.

$$\% \text{ Voltage Imbalance} = 100 \times \frac{\text{max voltage deviation from average voltage}}{\text{average voltage}}$$

Example: Supply voltage is 230-3-60



- AB = 224 v
- BC = 231 v
- AC = 226 v

$$\begin{aligned} \text{Average Voltage} &= \frac{(224 + 231 + 226)}{3} = \frac{681}{3} \\ &= 227 \end{aligned}$$

Determine maximum deviation from average voltage.

- (AB) 227 – 224 = 3 v
- (BC) 231 – 227 = 4 v
- (AC) 227 – 226 = 1 v

Maximum deviation is 4 v.

Determine percent of voltage imbalance.

$$\begin{aligned} \% \text{ Voltage Imbalance} &= 100 \times \frac{4}{227} \\ &= 1.76\% \end{aligned}$$

This amount of phase imbalance is satisfactory as it is below the maximum allowable 2%.

**IMPORTANT:** If the supply voltage phase imbalance is more than 2%, contact your local electric utility company immediately.

# SEQUENCE OF OPERATION

## General

The sequence below describes the sequence of operation for an electro-mechanical unit with and without a factory installed EconoMiSer® IV and X (called “economizer” in this sequence). For information regarding a direct digital controller, see the start-up, operations, and troubleshooting manual for the applicable controller.

### **Electro-mechanical units with no economizer**

#### **Cooling (Single speed indoor fan motor) —**

When the thermostat calls for cooling, terminals G and Y1 are energized. As a result, the indoor-fan contactor (IFC) and the compressor contactor (C1) are energized, causing the indoor-fan motor (IFM), compressor #1, and outdoor fan to start. If the unit has 2 stages of cooling, the thermostat will additionally energize Y2. On two compressor units, the Y2 signal will energize compressor contactor #2 (C2), causing compressor #2 to start. On 2-Stage 073 units, the Y1 signal energizes the IFC and C1 Contactor, causing the indoor fan and outdoor fan to start and the compressor to operate at 66% capacity. The Y2 signal will energize the compressor loader plug, allowing compressor to operate at 100% capacity. Regardless of the number of stages, the outdoor-fan motor runs continuously while unit is cooling.

#### **Cooling (2-speed indoor fan motor) —**

Per ASHRAE 90.1–2013 standard section 6.4.3.10.b, during the first stage of cooling operation the VFD will adjust the fan motor to provide 66% of the total cfm established for the unit. When a call for the second stage of cooling is required, the VFD will allow the total cfm for the unit established (100%).

#### **Heating**

**NOTE:** RGH units have either 1 or 2 stages of gas heat.

When the thermostat calls for heating, power is sent to W on the Integrated Gas Controller (IGC) board. An LED (light-emitting diode) on the IGC board turns on and remains on during normal operation. A check is made to ensure that the rollout switch and limit switch are closed. If the check was successful, the induced-draft motor is energized, and when its speed is satisfactory, as proven by the flue gas pressure switch, the ignition activation period begins. The burners will ignite within 5 seconds. If the burners do not light, there is a 22-second delay before another 5-second attempt. This sequence is repeated for 15 minutes or until the burners light. If, after the 15 minutes, the burners still have not lit, heating is locked out. To reset the control, break 24-v power to the thermostat.

When ignition occurs, the IGC board will continue to monitor the condition of the rollout switch, the limit switches, the flue gas pressure switch, as well as the flame sensor. 45 seconds after ignition occurs, assuming the unit is controlled through a room thermostat set for fan auto, the indoor-fan motor will energize (and the outdoor-air dampers will open to their minimum position). If, for some reason, the over-temperature limit opens prior to the start of the indoor fan blower, the unit will shorten the 45-second delay to 5 seconds less than

the time from initiation of heat to when the limit tripped. Gas will not be interrupted to the burners and heating will continue. Once the fan-on delay has been modified, it will not change back to 45 seconds until power is reset to the control.

On units with 2 stages of heat, when additional heat is required, W2 closes and initiates power to the second stage of the main gas valve. When the thermostat is satisfied, W1 and W2 open and the gas valve closes, interrupting the flow of gas to the main burners.

If the call for W1 lasted less than 1 minute, the heating cycle will not terminate until 1 minute after W1 became active. If the unit is controlled through a room thermostat set for fan auto, the indoor-fan motor will continue to operate for an additional 45 seconds then stop. If the over-temperature limit opens after the indoor motor is stopped, but within 10 minutes of W1 becoming inactive, on the next cycle the time will be extended by 15 seconds. The maximum delay is 3 minutes. Once modified, the fan off delay will not change back to 45 seconds unless power is reset to the control. A LED indicator is provided on the IGC to monitor operation.

### **Electro-mechanical units with an economizer**

#### **Cooling —**

When free cooling is not available, the compressors will be controlled by the zone thermostat. When free cooling is available, the outdoor-air damper is modulated by the EconoMiSer IV and X control to provide a 50°F (10°C) to 55°F (13°C) mixed-air temperature into the zone. As the mixed air temperature fluctuates above 55°F (13°C) or below 50°F (10°C) dampers will be modulated (open or close) to bring the mixed-air temperature back within control. If mechanical cooling is utilized with free cooling, the outdoor-air damper will maintain its current position at the time the compressor is started. If the increase in cooling capacity causes the mixed-air temperature to drop below 45°F (7°C), then the outdoor-air damper position will be decreased to the minimum position. If the mixed-air temperature continues to fall, the outdoor-air damper will close. Control returns to normal once the mixed-air temperature rises above 48°F (9°C). The power exhaust fans will be energized and de-energized, if installed, as the outdoor-air damper opens and closes.

If field-installed accessory CO<sub>2</sub> sensors are connected to the EconoMiSer IV and X control, a demand controlled ventilation strategy will begin to operate. As the CO<sub>2</sub> level in the zone increases above the CO<sub>2</sub> setpoint, the minimum position of the damper will be increased proportionally. As the CO<sub>2</sub> level decreases because of the increase in fresh air, the outdoor-air damper will be proportionally closed. For EconoMiSer IV and X operation, there must be a thermostat call for the fan (G). If the unit is occupied and the fan is on, the damper will operate at minimum position. Otherwise, the damper will be closed.

## SEQUENCE OF OPERATION (cont.)

When the EconoMiSer® IV and X control is in the occupied mode and a call for cooling exists (Y1 on the thermostat), the control will first check for indoor fan operation. If the fan is not on, then cooling will not be activated. If the fan is on, then the control will open the EconoMiSer IV and X damper to the minimum position.

On the initial power to the EconoMiSer IV and X control, it will take the damper up to 2 1/2 minutes before it begins to position itself. After the initial power-up, further changes in damper position can take up to 30 seconds to initiate. Damper movement from full closed to full open (or vice versa) will take between 1 1/2 and 2 1/2 minutes. If free cooling can be used as determined from the appropriate changeover command (switch, dry bulb, enthalpy curve, differential dry bulb, or differential enthalpy), then the control will modulate the dampers open to maintain the mixed-air temperature setpoint at 50°F (10°C) to 55°F (13°C). If there is a further demand for cooling (cooling second stage - Y2 is energized), then the control will bring on compressor stage 1 to maintain the mixed-air temperature setpoint. The EconoMiSer IV and X damper will be open at maximum position. EconoMiSer IV and X operation is limited to a single compressor.

**2-Speed Note:** When operating in ventilation mode only, the indoor fan motor will automatically adjust to 66% of the total cfm established.

### Heating

The sequence of operation for the heating is the same as an electro-mechanical unit with no economizer. The only difference is how the economizer acts. The economizer will stay at the Economizer Minimum Position while the evaporator fan is operating. The outdoor-air damper is closed when the indoor fan is not operating.

Refer to Service and Maintenance manual for further details.

### Optional Hot Gas Re-Heat Dehumidification System

Units with the factory equipped Hot Gas Re-Heat option are capable of providing multiple modes of improved dehumidification as a variation of the normal cooling cycle. The Hot Gas Re-Heat option includes additional valves in the liquid line and discharge line of each refrigerant circuit, a small reheat condenser coil downstream of the evaporator, and Motormaster variable-speed control of some or all outdoor fans. Operation of the revised refrigerant circuit for each mode is described below.

The Hot Gas Re-Heat system provides three sub-modes of operation: Cool, Reheat1, and Reheat2.

**Cool mode** - provides a normal ratio of Sensible and Latent Cooling effect from the evaporator coil.

**Reheat1** - provides increased Latent Cooling while slightly reducing the Sensible Cooling effect.

**Reheat2** - provides normal Latent Cooling but with null or minimum Sensible Cooling effect delivered to the space.

The Reheat1 and Reheat2 modes are available when the unit is not in a Heating mode and when the Low Ambient Lockout switch is closed.

The following diagrams depict piping for Single Stage cooling units (see page 92).

## SEQUENCE OF OPERATION (cont.)

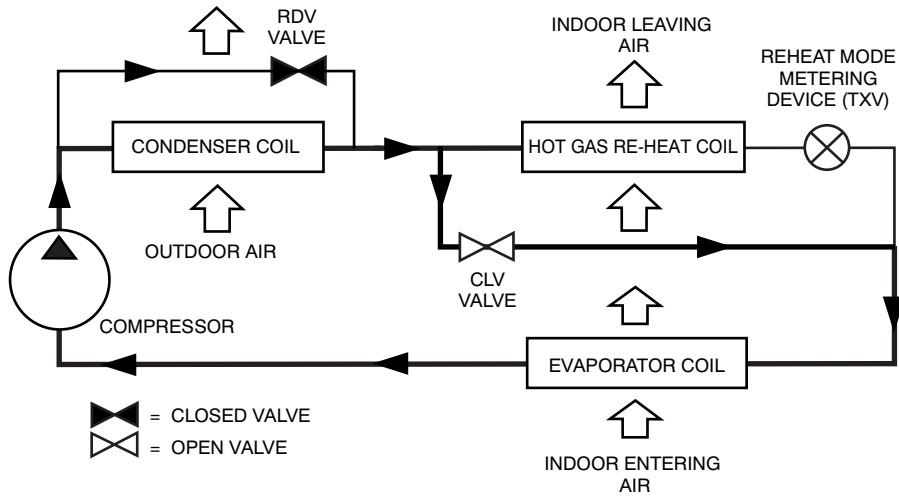

**Normal Cooling Mode - Hot Gas Re-Heat System with Single Stage Cooling**

C12702B

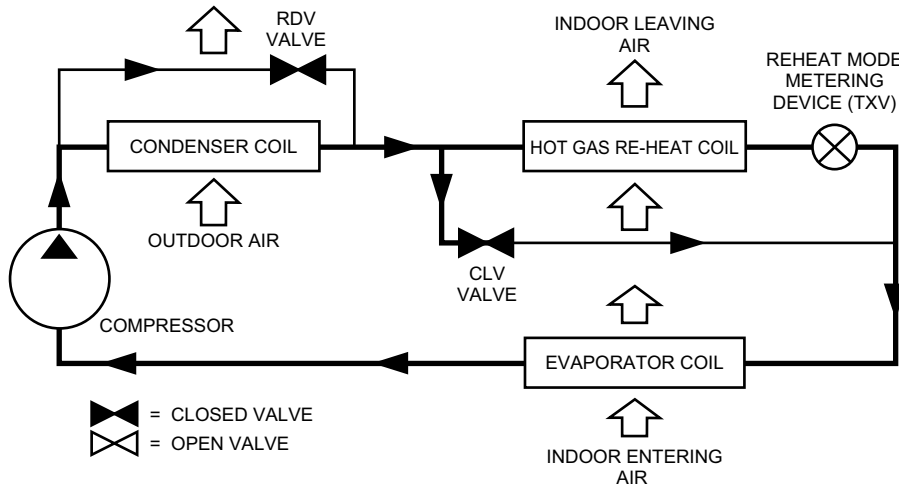

**Subcooling Mode (Reheat 1) - Hot Gas Re-Heat System with Single Stage Cooling**

C12703B

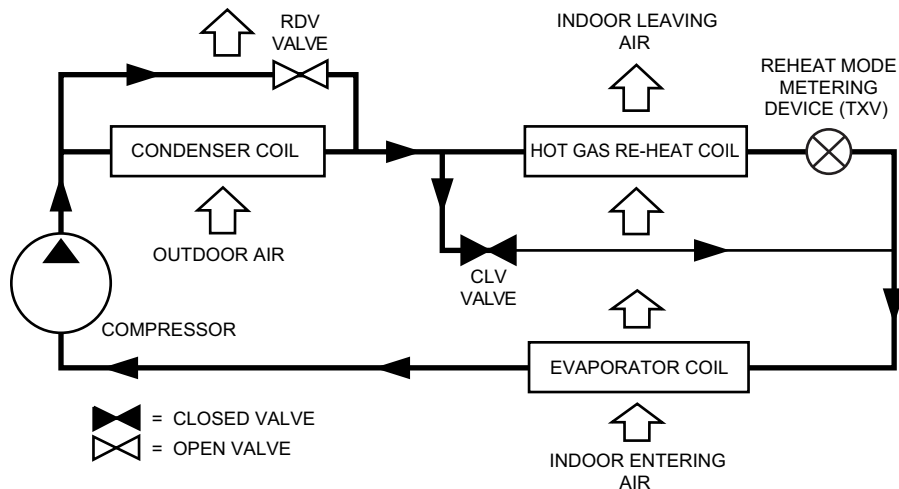

**Hot Gas Reheat Mode (Reheat2) - Hot Gas Re-Heat System with Single Stage Cooling**

C12704B

# GUIDE SPECIFICATIONS - RGH036 - 150

Note about this specification:

This specification is in the "Masterformat" as published by the Construction Specification Institute. Please feel free to copy this specification directly into your building spec.

## Gas Heat/Electric Cooling Packaged Rooftop

### HVAC Guide Specifications



#### Size Range: 3 to 12.5 Nominal Tons

Section	Description
---------	-------------

<b>23 06 80</b>	<b>Schedules for Decentralized HVAC Equipment</b>
-----------------	---

23 06 80.13	Decentralized Unitary HVAC Equipment Schedule
-------------	---

23 06 80.13.A.	Rooftop unit schedule
----------------	-----------------------

1. Schedule is per the project specification requirements.

<b>23 07 16</b>	<b>HVAC Equipment Insulation</b>
-----------------	----------------------------------

23 07 16.13	Decentralized, Rooftop Units:
-------------	-------------------------------

23 07 16.13.A.	Evaporator fan compartment:
----------------	-----------------------------

1. Interior cabinet surfaces shall be insulated with a minimum 1/2-in. thick, minimum 1 1/2 lb density, flexible fiberglass insulation bonded with a phenolic binder, neoprene coated on the air side.
2. Insulation and adhesive shall meet NFPA 90A requirements for flame spread and smoke generation.
3. Unit internal insulation linings shall be resistant to mold growth in accordance with "mold growth and humidity" test in ASTM C1338, G21, and UL 181 or comparable test method. Air stream surfaces shall be evaluated in accordance with the "Erosion Test" in UL 181, as part of ASTM C1071.

23 07 16.13.B.	Gas heat compartment:
----------------	-----------------------

1. Aluminum foil-faced fiberglass insulation shall be used.
2. Insulation and adhesive shall meet NFPA 90A requirements for flame spread and smoke generation.

<b>23 09 13</b>	<b>Instrumentation and Control Devices for HVAC</b>
-----------------	---

23 09 13.23	Sensors and Transmitters
-------------	--------------------------

23 09 13.23.A.	Thermostats
----------------	-------------

1. Thermostat must
  - a. energize both "W" and "G" when calling for heat.
  - b. have capability to energize 2 different stages of cooling, and 2 different stages of heating.
  - c. include capability for occupancy scheduling.

<b>23 09 33</b>	<b>Electric and Electronic Control System for HVAC</b>
-----------------	--

23 09 33.13	Decentralized, Rooftop Units:
-------------	-------------------------------

23 09 33.13.A.	General:
----------------	----------

1. Shall be complete with self-contained low-voltage control circuit protected by a resettable circuit breaker on the 24-v transformer side. Transformer shall have 75VA capability.
2. Shall utilize color-coded wiring.
3. Shall include a central control terminal board to conveniently and safely provide connection points for vital control functions such as: smoke detectors, phase monitor, gas controller, economizer, thermostat, DDC control options, and low and high pressure switches.
4. The heat exchanger shall be controlled by an integrated gas controller (IGC) microprocessor. See heat exchanger section of this specification.
5. Unit shall include a minimum of one 8-pin screw terminal connection board for connection of control wiring.

23 09 33.13.B.	Safeties:
----------------	-----------

1. Compressor over-temperature, over-current. High internal pressure differential.
2. Low-pressure switch.

- a. Units with 2 compressors shall have different sized connectors for the circuit 1 and circuit 2 low and high pressure switches. They shall physically prevent the cross-wiring of the safety switches between circuits 1 and 2.
  - b. Low-pressure switch shall use different color wire than the high-pressure switch. The purpose is to assist the installer and service technician to correctly wire and or troubleshoot the rooftop unit.
3. High-pressure switch.
- a. Units with 2 compressors shall have different sized connectors for the circuit 1 and circuit 2 low and high pressure switches. They shall physically prevent the cross-wiring of the safety switches between circuits 1 and 2.
  - b. High-pressure switch shall use different color wire than the low-pressure switch. The purpose is to assist the installer and service technician to correctly wire and or troubleshoot the rooftop unit.
4. Automatic reset, motor thermal overload protector.
5. Heating section shall be provided with the following minimum protections:
- a. High-temperature limit switches.
  - b. Induced draft motor speed sensor.
  - c. Flame rollout switch.
  - d. Flame proving controls.

**23 09 93 Sequence of Operations for HVAC Controls**

23 09 93.13 Decentralized, Rooftop Units:

23 09 93.13.A. INSERT SEQUENCE OF OPERATION

**23 40 13 Panel Air Filters**

23 40 13.13 Decentralized, Rooftop Units:

23 40 13.13.A. Standard filter section

- 1. Shall consist of factory-installed, low velocity, disposable 2-in. thick fiberglass filters of commercially available sizes.
- 2. Unit shall use only one filter size. Multiple sizes are not acceptable.
- 3. Filters shall be accessible through an access panel with “no-tool” removal as described in the unit cabinet section of this specification (23 81 19.13.G).

**23 81 19 Self-Contained Air Conditioners**

23 81 19.13 Small-Capacity Self-Contained Air Conditioners (RGH036-150)

23 81 19.13.A. General

- 1. Outdoor, rooftop mounted, electrically controlled, heating and cooling unit utilizing a fully hermetic scroll compressor(s) for cooling duty and gas combustion for heating duty.
- 2. Factory assembled, single-piece heating and cooling rooftop unit. Contained within the unit enclosure shall be all factory wiring, piping, controls, and special features required prior to field start-up.
- 3. Unit shall use R-410A refrigerant.
- 4. Unit shall be installed in accordance with the manufacturer’s instructions.
- 5. Unit must be selected and installed in compliance with local, state, and federal codes.

23 81 19.13.B. Quality Assurance

- 1. Unit meets ASHRAE 90.1-2013 minimum efficiency requirements.
- 2. 3-phase units are ENERGY STAR\* certified.
- 3. Unit shall be rated in accordance with AHRI Standards 210/240 and 340/360.
- 4. Unit shall be designed to conform to ASHRAE 15.
- 5. Unit shall be UL-tested and certified in accordance with ANSI Z21.47 Standards and UL or ETL-listed and certified under Canadian standards as a total package for safety requirements.
- 6. Insulation and adhesive shall meet NFPA 90A requirements for flame spread and smoke generation.
- 7. Unit internal insulation linings shall be resistant to mold growth in accordance with “mold growth and humidity” test in ASTM C1338, G21, and UL 181 or comparable test method. Air stream surfaces shall be evaluated in accordance with the “Erosion Test” in UL 181, as part of ASTM C1071.
- 8. Unit casing shall be capable of withstanding 500-hour salt spray exposure per ASTM B117 (scribed specimen).
- 9. Roof curb shall be designed to conform to NRCA Standards.

\* ENERGY STAR is a registered trademark of the U.S. Environmental Protection Agency.

10. Unit shall be subjected to a completely automated run test on the assembly line. The data for each unit will be stored at the factory, and must be available upon request.
  11. Unit shall be designed in accordance with UL Standard 1995, including tested to withstand rain.
  12. Unit shall be constructed to prevent intrusion of snow and tested to prevent snow intrusion into the control box up to 40 mph.
  13. Unit shake tested to assurance level 1, ASTM D4169 to ensure shipping reliability.
  14. High Efficient Motors listed shall meet section 313 of the Energy Independence and Security Act of 2007 (EISA 2007).
- 23 81 19.13.C. Delivery, Storage, and Handling
1. Unit shall be stored and handled per manufacturer's recommendations.
  2. Lifted by crane requires either shipping top panel or spreader bars.
  3. Unit shall only be stored or positioned in the upright position.
- 23 81 19.13.D. Project Conditions
1. As specified in the contract.
- 23 81 19.13.E. Operating Characteristics
1. Unit shall be capable of starting and running at 125°F (52°C) ambient outdoor temperature, meeting maximum load criteria of AHRI Standard 210/240 or 340/360 at ± 10% voltage.
  2. Compressor with standard controls shall be capable of operation down to 35°F (2°C), ambient outdoor temperatures. Accessory low ambient kits shall be available if operation below 35°F (2°C), is required. See below for head pressure control package or winter start kit.
  3. Unit shall discharge supply air vertically or horizontally as shown on contract drawings.
  4. Unit shall be factory configured for vertical supply & return configurations.
  5. Unit shall be field convertible from vertical to horizontal airflow on all models. No special kit required on 036-120 models. Supply duct kit required for 150 size model only.
  6. Unit shall be capable of mixed operation: vertical supply with horizontal return or horizontal supply with vertical return.
- 23 81 19.13.F. Electrical Requirements
1. Main power supply voltage, phase, and frequency must match those required by the manufacturer.
  2. Control Panel SCCR (short circuit current rating): 5kA RMS at Rated Symmetrical Voltage
- 23 81 19.13.G. Unit Cabinet
1. Unit cabinet shall be constructed of galvanized steel, and shall be bonderized and coated with a pre-painted baked enamel finish on all externally exposed surfaces.
  2. Unit cabinet exterior paint shall be: film thickness, (dry) 0.003 inches minimum, gloss (per ASTM D523, 60°F / 16°C): 60, Hardness: H-2H Pencil hardness.
  3. Evaporator fan compartment interior cabinet insulation shall conform to AHRI Standards 210/240 or 340/360 minimum exterior sweat criteria. Interior surfaces shall be insulated with a minimum 1/2-in. thick, 1 lb density, flexible fiberglass insulation, neoprene coated on the air side. Aluminum foil-faced fiberglass insulation shall be used in the gas heat compartment.
  4. Unit internal insulation linings shall be resistant to mold growth in accordance with "mold growth and humidity" test in ASTM C1338, G21, and UL 181 or comparable test method. Air stream surfaces shall be evaluated in accordance with the "Erosion Test" in UL 181, as part of ASTM C1071.
  5. Base of unit shall have a minimum of four locations for thru-the-base gas and electrical connections (factory installed or field installed), standard.
  6. Base Rail
    - a. Unit shall have base rails on a minimum of 3 sides.
    - b. Holes shall be provided in the base rails for rigging shackles to facilitate maneuvering and overhead rigging.
    - c. Holes shall be provided in the base rail for moving the rooftop by fork truck.
    - d. Base rail shall be a minimum of 16 gauge thickness.
  7. Condensate pan and connections:
    - a. Shall be an internally sloped condensate drain pan made of a non-corrosive material.
    - b. Shall comply with ASHRAE Standard 62.
    - c. Shall use a 3/4-in -14 NPT drain connection, possible either through the bottom or side of the drain pan. Connection shall be made per manufacturer's recommendations.
  8. Top panel:
    - a. Shall be a single piece top panel on 036 thru 120 sizes, two piece on 150 size.

9. Gas Connections:

- a. All gas piping connecting to unit gas valve shall enter the unit cabinet at a single location on side of unit (horizontal plane).
- b. Thru-the-base capability
  - (1.) Standard unit shall have a thru-the-base gas-line location using a raised, embossed portion of the unit basepan.
  - (2.) Optional, factory-approved, water-tight connection method must be used for thru-the-base gas connections.
  - (3.) No basepan penetration, other than those authorized by the manufacturer, is permitted.

10. Electrical Connections

- a. All unit power wiring shall enter unit cabinet at a single, factory-prepared, knockout location.
- b. Thru-the-base capability.
  - (1.) Standard unit shall have a thru-the-base electrical location (s) using a raised, embossed portion of the unit basepan.
  - (2.) Optional, factory-approved, water-tight connection method must be used for thru-the-base electrical connections.
  - (3.) No basepan penetration, other than those authorized by the manufacturer, is permitted.

11. Component access panels (standard)

- a. Cabinet panels shall be easily removable for servicing.
- b. Unit shall have one factory installed, tool-less, removable, filter access panel.
- c. Panels covering control box, indoor fan, indoor fan motor, gas components (where applicable), and compressors shall have molded composite handles.
- d. Handles shall be UV modified, composite. They shall be permanently attached, and recessed into the panel.
- e. Screws on the vertical portion of all removable access panel shall engage into heat resistant, molded composite collars.
- f. Collars shall be removable and easily replaceable using manufacturer recommended parts.

23 81 19.13.H. Gas Heat

1. General

- a. Heat exchanger shall be an induced draft design. Positive pressure heat exchanger designs shall not be allowed.
- b. Shall incorporate a direct-spark ignition system and redundant main gas valve.
- c. Gas supply pressure at the inlet to the rooftop unit gas valve must match that required by the manufacturer.

2. The heat exchanger shall be controlled by an integrated gas controller (IGC) microprocessor.

- a. IGC board shall notify users of fault using an LED (light-emitting diode).
- b. IGC board shall contain algorithms that modify evaporator-fan operation to prevent future cycling on high temperature limit switch.
- c. Unit shall be equipped with anti-cycle protection with one short cycle on unit flame rollout switch or 4 continuous short cycles on the high temperature limit switch. Fault indication shall be made using an LED.

3. Standard Heat Exchanger construction

- a. Heat exchanger shall be of the tubular-section type constructed of a minimum of 20-gauge steel coated with a nominal 1.2 mil aluminum-silicone alloy for corrosion resistance.
- b. Burners shall be of the in-shot type constructed of aluminum-coated steel.
- c. Burners shall incorporate orifices for rated heat output up to 2000 ft (610m) elevation. Additional accessory kits may be required for applications above 2000 ft (610m) elevation, depending on local gas supply conditions.
- d. Each heat exchanger tube shall contain multiple dimples for increased heating effectiveness.

4. Optional Stainless Steel Heat Exchanger construction

- a. Use energy saving, direct-spark ignition system.
- b. Use a redundant main gas valve.
- c. Burners shall be of the in-shot type constructed of aluminum-coated steel.
- d. All gas piping shall enter the unit cabinet at a single location on side of unit (horizontal plane).
- e. The optional stainless steel heat exchanger shall be of the tubular-section type, constructed of a minimum of 20-gauge type 409 stainless steel.

- f. Type 409 stainless steel shall be used in heat exchanger tubes and vestibule plate.
  - g. Complete stainless steel heat exchanger allows for greater application flexibility.
5. Optional Low NO<sub>x</sub> Heat Exchanger construction
- a. Low NO<sub>x</sub> reduction shall be provided to reduce nitrous oxide emissions to meet California's Air Quality Management District (SCAQMD) low-NO<sub>x</sub> emissions requirement of 40 nanograms per joule or less.
  - b. Primary tubes and vestibule plates on low NO<sub>x</sub> units shall be 409 stainless steel. Other components shall be aluminized steel.
6. Induced draft combustion motor and blower
- a. Shall be a direct-drive, single inlet, forward-curved centrifugal type.
  - b. Shall be made from steel with a corrosion-resistant finish.
  - c. Shall have permanently lubricated sealed bearings.
  - d. Shall have inherent thermal overload protection.
  - e. Shall have an automatic reset feature.

23 81 19.13.I. Coils

1. Standard Aluminum Fin/Copper Tube Coils:
- a. Standard evaporator and condenser coils shall have aluminum lanced plate fins mechanically bonded to seamless internally grooved copper tubes with all joints brazed.
  - b. Evaporator coils shall be leak tested to 150 psig, pressure tested to 450 psig, and qualified to UL 1995 burst test at 1775 psig.
  - c. Condenser coils shall be leak tested to 150 psig, pressure tested to 650 psig, and qualified to UL 1995 burst test at 1980 psig.
2. Optional Pre-coated aluminum-fin condenser coils (3-phase models only):
- a. Shall have a durable epoxy-phenolic coating to provide protection in mildly corrosive coastal environments.
  - b. Coating shall be applied to the aluminum fin stock prior to the fin stamping process to create an inert barrier between the aluminum fin and copper tube.
  - c. Epoxy-phenolic barrier shall minimize galvanic action between dissimilar metals.
  - d. Corrosion durability of fin stock shall be confirmed through testing to be no less than 6000 hours salt spray per ASTM B117-90.
  - e. Corrosion durability of fin stock shall be confirmed through testing to have no visible corrosion after 48 hour immersion in a room temperature solution of 5% salt, 1% acetic acid.
  - f. Fin stock coating shall pass 2000 hours of the following: one week exposure in the prohesion chamber followed by one week of accelerated ultraviolet light testing. Prohesion chamber: the solution shall contain 3.5% sodium chloride and 0.35% ammonium sulfate. The exposure cycle is one hour of salt fog application at ambient followed by one hour drying at 95°F (35°C).
3. Optional Copper-fin evaporator and condenser coils (3-phase models only) :
- a. Shall be constructed of copper fins mechanically bonded to copper tubes and copper tube sheets.
  - b. Galvanized steel tube sheets shall not be acceptable.
  - c. A polymer strip shall prevent coil assembly from contacting the sheet metal coil pan to minimize potential for galvanic corrosion between coil and pan.
4. Optional E-coated aluminum-fin evaporator and condenser coils (3-phase models only):
- a. Shall have a flexible epoxy polymer coating uniformly applied to all coil surface areas without material bridging between fins.
  - b. Coating process shall ensure complete coil encapsulation of tubes, fins and headers.
  - c. Color shall be high gloss black with gloss per ASTM D523-89.
  - d. Uniform dry film thickness from 0.8 to 1.2 mil on all surface areas including fin edges.
  - e. Superior hardness characteristics of 2H per ASTM D3363-92A and cross-hatch adhesion of 4B-5B per ASTM D3359-93.
  - f. Impact resistance shall be up to 160 in.-lb (ASTM D2794-93).
  - g. Humidity and water immersion resistance shall be up to minimum 1000 and 250 hours respectively (ASTM D2247-92 and ASTM D870-92).
  - h. Corrosion durability shall be confirmed through testing to be no less than 6000 hours salt spray per ASTM B117-90.
5. Optional E-coated aluminum-fin, aluminum tube condenser coils:

- a. Shall have a flexible epoxy polymer coating uniformly applied to all coil external surface areas without material bridging between fins or louvers.
- b. Coating process shall ensure complete coil encapsulation, including all exposed fin edges.
- c. E-coat thickness of 0.8 to 1.2 mil with top coat having a uniform dry film thickness from 1.0 to 2.0 mil on all external coil surface areas, including fin edges, shall be provided.
- d. Shall have superior hardness characteristics of 2H per ASTM D3363-00 and cross-hatch adhesion of 4B-5B per ASTM D3359-02.
- e. Shall have superior impact resistance with no cracking, chipping or peeling per NSF/ANSI 51-2002 Method 10.2.

23 81 19.13.J. Refrigerant Components

1. Refrigerant circuit shall include the following control, safety, and maintenance features:
  - a. Thermostatic Expansion Valve (TXV) shall help provide optimum performance across the entire operating range. Shall contain removable power element to allow change out of power element and bulb without removing the valve body.
  - b. Refrigerant filter drier – Solid core design.
  - c. Service gauge connections on suction and discharge lines.
  - d. Pressure gauge access through a specially designed access port in the top panel of the unit.
2. There shall be gauge line access port in the skin of the rooftop, covered by a black, removable plug.
  - a. The plug shall be easy to remove and replace.
  - b. When the plug is removed, the gauge access port shall enable maintenance personnel to route their pressure gauge lines.
  - c. This gauge access port shall facilitate correct and accurate condenser pressure readings by enabling the reading with the compressor access panel on.
  - d. The plug shall be made of a leak proof, UV-resistant, composite material.
3. Compressors
  - a. Unit shall use fully hermetic, scroll compressor for each independent refrigeration circuit.
  - b. Models shall be available with single compressor/single stage cooling designs on 036 – 072 sizes models, single compressor/2-stage cooling on 073 size, and 2 compressor/2-stage cooling models on 090 – 150 sizes.
  - c. Compressor motors shall be cooled by refrigerant gas passing through motor windings.
  - d. Compressors shall be internally protected from high discharge temperature conditions.
  - e. Compressors shall be protected from an over-temperature and over-ampereage conditions by an internal, motor overload device.
  - f. Compressor shall be factory mounted on rubber grommets.
  - g. Compressor motors shall have internal line break thermal, current overload and high pressure differential protection.
  - h. Crankcase heaters shall not be required for normal operating range, unless provided by the factory.

23 81 19.13.K. Filter Section

1. Filters access is specified in the unit cabinet section of this specification.
2. Filters shall be held in place by a pivoting filter tray, facilitating easy removal and installation.
3. Shall consist of factory-installed, low velocity, throw-away 2-in. thick fiberglass filters.
4. Filters shall be standard, commercially available sizes.
5. Only one size filter per unit is allowed.

23 81 19.13.L. Evaporator Fan and Motor

1. Evaporator fan motor:
  - a. Shall have permanently lubricated bearings.
  - b. Shall have inherent automatic-reset thermal overload protection or circuit breaker.
  - c. Shall have a maximum continuous bhp rating for continuous duty operation; no safety factors above that rating shall be required.
2. Electric Drive (Direct Drive) X13 – 5 Speed/Torque Evaporator Fan:
  - a. Multi-speed motor with easy quick adjustment settings.
  - b. Blower fan shall be double-inlet type with forward-curved blades.
  - c. Shall be constructed from steel with a corrosion resistant finish and dynamically balanced.
  - d. Standard on all 036-060 models with 208/230/1/60 operation without Hot Gas Re-Heat
  - e. Standard on all 036-060 3-phase models without Hot Gas Re-Heat, with optional belt drive.

3. Belt-driven Evaporator Fan:
  - a. Belt drive shall include an adjustable-pitch motor pulley.
  - b. Shall use sealed, permanently lubricated ball-bearing type.
  - c. Blower fan shall be double-inlet type with forward-curved blades.
  - d. Shall be constructed from steel with a corrosion resistant finish and dynamically balanced.
  - e. Standard on all 072-150 size and 036-060 with Hot Gas Re-Heat models. Optional on all 036-060 3-phase models.

23 81 19.13.M. Condenser Fans and Motors

1. Condenser fan motors:
  - a. Shall be a totally enclosed motor.
  - b. Shall use permanently lubricated bearings.
  - c. Shall have inherent thermal overload protection with an automatic reset feature.
  - d. Shall use a shaft-down design on 036 to 120 models and shaft-up on 150 size with rain shield.
2. Condenser Fans:
  - a. Shall be a direct-driven propeller type fan.
  - b. Shall have galvalum blades riveted to steel spiders that have corrosion-resistant properties and shall be dynamically balanced.

23 81 19.13.N. Special Features Options and Accessories

1. 2-Speed Indoor Fan Motor for 2-stage cooling models only:
  - a. Evaporator fan motor:
    - (1.) Shall have permanently lubricated bearings.
    - (2.) Shall have a maximum continuous bhp rating for continuous duty operation; no safety factors above that rating.
    - (3.) Shall be Variable Frequency duty and 2-speed control.
    - (4.) Shall contain motor shaft grounding ring to prevent electrical bearing fluting damage by safely diverting harmful shaft voltages and bearing currents to ground.
2. Variable Frequency Drive (VFD). Only available on 2-speed indoor fan motor option:
  - a. Factory-supplied VFDs qualify, through ABB for a 24-month warranty from date of commissioning or 30 months from date of sale, whichever occurs first.
  - b. Shall be installed inside the unit cabinet, mounted, wired and tested.
  - c. Shall contain Electromagnetic Interference (EMI) frequency protection.
  - d. Insulated Gate Bi-Polar Transistors (IGBT) used to produce the output pulse width modulated (PWM) waveform, allowing for quiet motor operation.
  - e. Self diagnostics with fault and power code LED indicator. Field accessory Display Kit available for further diagnostics and special setup applications.
  - f. RS485 capability standard.
  - g. Electronic thermal overload protection.
  - h. 5% swinging chokes for harmonic reduction and improved power factor.
  - i. All printed circuit boards shall be conformal coated.
3. Integrated EconoMiSer® IV, EconoMiSer2, and EconoMiSer X standard leak rate models. (Factory installed on 3 phase models only. Field installed on all 3 and 1 phase models)
  - a. Integrated, gear driven opposing modulating blade design type capable of simultaneous economizer and compressor operation.
  - b. Independent modules for vertical or horizontal return configuration shall be available. Vertical return modules shall be available as a factory installed option.
  - c. Damper blades shall be galvanized steel with composite gears. Plastic or composite blades on intake or return shall not be acceptable.
  - d. Shall include all hardware and controls to provide free cooling with outdoor air when temperature and/or humidity are below setpoints.
  - e. Shall be equipped with gear driven dampers for both the outdoor ventilation air and the return air for positive air stream control.
  - f. Standard leak rate shall be equipped with dampers not to exceed 2% leakage at 1 in. wg pressure differential.
  - g. Economizer controller on EconoMiSer IV models shall be the Honeywell W7212 that provides:

- (1.) Combined minimum and DCV maximum damper position potentiometers with compressor staging relay.
  - (2.) Functions with solid state analog enthalpy or dry bulb changeover control sensing.
  - (3.) Contain LED indicates for: when free cooling is available, when module is in DCV mode, when exhaust fan contact is closed.
- h. Economizer controller on EconoMiSer® X models shall be the Honeywell W7220 that provides:
- (1.) 2-line LCD interface screen for setup, configuration and troubleshooting
  - (2.) On-board Fault Detection and Diagnostics (FDD) that senses and alerts when the economizer is not operating properly, per California Title 24.
  - (3.) Sensor failure loss of communication identification
  - (4.) Automatic sensor detection
  - (5.) Capabilities for use with multiple-speed indoor fan systems
  - (6.) Utilize digital sensors: Dry bulb and Enthalpy
- i. Shall be capable of introducing up to 100% outdoor air.
- j. Shall be equipped with a barometric relief damper capable of relieving up to 100% return air and contain seals that meet ASHRAE 90.1-2013 requirements.
- k. Shall be designed to close damper(s) during loss-of-power situations with spring return built into motor.
- l. Dry bulb outdoor air temperature sensor shall be provided as standard. Enthalpy sensor is also available on factory installed only. Outdoor air sensor setpoint shall be adjustable and shall range from 40 to 100° F (4 to 38° C). Additional sensor options shall be available as accessories.
- m. The economizer controller shall also provide control of an accessory power exhaust unit function. Factory set at 100%, with a range of 0% to 100%.
- n. The economizer shall maintain minimum airflow into the building during occupied period and provide design ventilation rate for full occupancy.
- o. Dampers shall be completely closed when the unit is in the unoccupied mode.
- p. Economizer controller shall accept a 2-10 Vdc CO<sub>2</sub> sensor input for IAQ/DCV control. In this mode, dampers shall modulate the outdoor air damper to provide ventilation based on the sensor input.
- q. Compressor lockout temperature on W7220 is adjustable from -45° F to 80° F, set at a factory default of 32° F. Others shall open at 35° F (2° C) and closes at 50° F (10° C)
- r. Actuator shall be direct coupled to economizer gear. No linkage arms or control rods shall be acceptable.
- s. Economizer controller shall provide indications when in free cooling mode, in the DCV mode, or the exhaust fan contact is closed.
4. Integrated EconoMiSer 2, and EconoMiSer X Ultra Low Leak rate models. (Factory installed on 3 phase models only. Field installed on all 3 and 1 phase models)
- a. Integrated, gear driven opposing modulating blade design type capable of simultaneous economizer and compressor operation.
  - b. Independent modules for vertical or horizontal return configuration shall be available. Vertical return modules shall be available as a factory installed option.
  - c. Damper blades shall be galvanized steel with composite gears. Plastic or composite blades on intake or return shall not be acceptable.
  - d. Shall include all hardware and controls to provide free cooling with outdoor air when temperature and/or humidity are below setpoints.
  - e. Shall be equipped with gear driven dampers for both the outdoor ventilation air and the return air for positive air stream control.
  - f. Ultra Low Leak design meets California Title 24 section 140.4 and ASHRAE 90.1-2013 requirements of 4 cfm per sq. ft. on the outside air dampers and 10 cfm per sq. ft. on the return dampers.
  - g. Economizer controller on EconoMiSer X models shall be the Honeywell W7220 that provides:
    - (1.) 2-line LCD interface screen for setup, configuration and troubleshooting
    - (2.) On-board Fault Detection and Diagnostics (FDD) that senses and alerts when the economizer is not operating properly, per California Title 24.
    - (3.) Sensor failure loss of communication identification
    - (4.) Automatic sensor detection
    - (5.) Capabilities for use with multiple-speed indoor fan systems
    - (6.) Utilize digital sensors: Dry bulb and Enthalpy
  - h. Shall be capable of introducing up to 100% outdoor air.

- i. Shall be equipped with a barometric relief damper capable of relieving up to 100% return air and contain seals that meet ASHRAE 90.1-2013 requirements.
  - j. Shall be designed to close damper(s) during loss-of-power situations with spring return built into motor.
  - k. Dry bulb outdoor air temperature sensor shall be provided as standard. Enthalpy sensor is also available on factory installed only. Outdoor air sensor setpoint shall be adjustable and shall range from 40 to 100° F (4 to 38° C). Additional sensor options shall be available as accessories.
  - l. The economizer controller shall also provide control of an accessory power exhaust unit function. Factory set at 100%, with a range of 0% to 100%.
  - m. The economizer shall maintain minimum airflow into the building during occupied period and provide design ventilation rate for full occupancy.
  - n. Dampers shall be completely closed when the unit is in the unoccupied mode.
  - o. Economizer controller shall accept a 2-10 Vdc CO<sub>2</sub> sensor input for IAQ/DCV control. In this mode, dampers shall modulate the outdoor air damper to provide ventilation based on the sensor input.
  - p. Compressor lockout temperature on W7220 is adjustable from -45 F to 80° F, set at a factory default of 32° F. Others shall open at 35° F (2° C) and closes at 50° F (10° C).
  - q. Actuator shall be direct coupled to economizer gear. No linkage arms or control rods shall be acceptable.
  - r. Economizer controller shall provide indications when in free cooling mode, in the DCV mode, or the exhaust fan contact is closed.
5. Two-Position Damper (Factory installed on 3 Phase Models Only. Field installed on all 3 and 1 Phase Models)
- a. Damper shall be a Two-Position Damper. Damper travel shall be from the full closed position to the field adjustable %-open setpoint.
  - b. Damper shall include adjustable damper travel from 25% to 100% (full open).
  - c. Damper shall include single or dual blade, gear driven dampers and actuator motor.
  - d. Actuator shall be direct coupled to damper gear. No linkage arms or control rods shall be acceptable.
  - e. Damper will admit up to 100% outdoor air for applicable rooftop units.
  - f. Damper shall close upon indoor (evaporator) fan shutoff and/or loss of power.
  - g. The damper actuator shall plug into the rooftop unit's wiring harness plug. No hard wiring shall be required.
  - h. Outside air hood shall include aluminum water entrainment filter.
  - i. Not available with 2-Speed Indoor Fan Motor models.
6. Manual damper
- a. Manual damper package shall consist of damper, air inlet screen, and rain hood which can be preset to admit up to 25 or 50% outdoor air for year round ventilation.
  - b. Not available with 2-Speed Indoor Fan Motor models.
7. Hot Gas Re-Heat Adaptive Dehumidification System (3-phase models only):
- a. The Hot Gas Re-Heat Adaptive Dehumidification System shall be factory installed and shall provide greater dehumidification of the occupied space by two modes of dehumidification operations in addition to its normal design cooling mode:
    - (1.) Subcooling mode further sub cools the hot liquid refrigerant leaving the condenser coil when both temperature and humidity in the space are not satisfied.
    - (2.) Hot gas reheat mode shall mix a portion of the hot gas from the discharge of the compressor with the hot liquid refrigerant leaving the condenser coil to create a two-phase heat transfer in the system, resulting in a neutral leaving air temperature when only humidity in the space is not satisfied.
    - (3.) Includes head pressure controller.
8. Head Pressure Control Package (Motormaster<sup>®</sup>)
- a. Controller shall control coil head pressure by condenser-fan speed modulation or condenser-fan cycling and wind baffles.
  - b. Shall consist of solid-state control and condenser-coil temperature sensor to maintain condensing temperature at outdoor ambient temperatures down to -20° F (-29° C).
9. Low Ambient Controller (Factory-installed only)
- a. Controller shall control coil head pressure by condenser-fan speed modulation or condenser-fan cycling and wind baffles.
  - b. Shall consist of solid-state control and condenser-coil temperature sensor to maintain condensing temperature at outdoor ambient temperatures down to 0° F (-18° C). (Not available on 110 size models as standard unit cooling operation down to 0° F /-18° C).

10. Propane Conversion Kit
  - a. Package shall contain all the necessary hardware and instructions to convert a standard natural gas unit for use with liquefied propane, up to 2000 ft (610m) elevation.
  - b. Additional accessory kits may be required for applications above 2000 ft (610m) elevation.
11. Flue Shield (036-120 models only)
  - a. Flue shield shall provide protection from the hot sides of the gas flue hood.
12. Condenser Coil Hail Guard Assembly (Factory installed option on 3-phase models. Field installed on all 3 and 1 phase models):
  - a. Shall protect against damage from hail.
  - b. Shall be of louvered style.
13. Unit-Mounted, Non-Fused Disconnect Switch:
  - a. Switch shall be factory-installed, internally mounted.
  - b. National Electric Code (NEC) and UL or ETL approved non-fused switch shall provide unit power shutoff.
  - c. Shall be accessible from outside the unit.
  - d. Shall provide local shutdown and lockout capability.
  - e. Sized only for the unit as ordered from the factory. Does not accommodate field-installed devices.
14. Convenience Outlet:
  - a. Powered convenience outlet.
    - (1.) Outlet shall be powered from main line power to the rooftop unit.
    - (2.) Outlet shall be powered from line side or load side of disconnect by installing contractor, as required by code. If outlet is powered from load side of disconnect, unit electrical ratings shall be UL or ETL certified and rated for additional outlet amperage.
    - (3.) Outlet shall be factory-installed and internally mounted with easily accessible 115-v female receptacle.
    - (4.) Outlet shall include 15 amp GFI receptacles with independent fuse protection.
    - (5.) Voltage required to operate convenience outlet shall be provided by a factory-installed step-down transformer.
    - (6.) Outlet shall be accessible from outside the unit.
    - (7.) Outlet shall include a field-installed "Wet in Use" cover.
  - b. Non-Powered convenience outlet.
    - (1.) Outlet shall be powered from a separate 115/120v power source.
    - (2.) A transformer shall not be included.
    - (3.) Outlet shall be factory-installed and internally mounted with easily accessible 115-v female receptacle.
    - (4.) Outlet shall include 15 amp GFI receptacles with independent fuse protection.
    - (5.) Outlet shall be accessible from outside the unit.
    - (6.) Outlet shall include a field-installed "Wet in Use" cover.
15. Flue Discharge Deflector:
  - a. Flue discharge deflector shall direct unit exhaust vertically instead of horizontally.
  - b. Deflector shall be defined as a "natural draft" device by the National Fuel and Gas (NFG) code.
16. Thru-the-Base Connectors:
  - a. Kits shall provide connectors to permit gas and electrical connections to be brought to the unit through the unit basepan.
  - b. Minimum of four connection locations per unit.
17. Propeller Power Exhaust:
  - a. Power exhaust shall be used in conjunction with an integrated economizer.
  - b. Independent modules for vertical or horizontal return configurations shall be available.
  - c. Horizontal power exhaust is shall be mounted in return ductwork.
  - d. Power exhaust shall be controlled by economizer controller operation. Exhaust fans shall be energized when dampers open past the 0-100% adjustable setpoint on the economizer control.
18. Roof Curbs (Vertical):
  - a. Full perimeter roof curb with exhaust capability providing separate air streams for energy recovery from the exhaust air without supply air contamination.
  - b. Formed galvanized steel with wood nailer strip and shall be capable of supporting entire unit weight.

- c. Permits installation and securing of ductwork to curb prior to mounting unit on the curb.
19. High Altitude Gas Conversion Kit:
    - a. Package shall contain all the necessary hardware and instructions to convert a standard natural gas unit to operate from 2000–7000 ft (610 to 2134m) elevation with natural gas or from 0–7000 ft (0–2134m) elevation with liquefied propane.
  20. Outdoor Air Enthalpy Sensor:
    - a. The outdoor air enthalpy sensor shall be used to provide single enthalpy control. When used in conjunction with a return air enthalpy sensor, the unit will provide differential enthalpy control. The sensor allows the unit to determine if outside air is suitable for free cooling.
  21. Return Air Enthalpy Sensor:
    - a. The return air enthalpy sensor shall be used in conjunction with an outdoor air enthalpy sensor to provide differential enthalpy control.
  22. Indoor Air Quality (CO<sub>2</sub>) Sensor:
    - a. Shall be able to provide demand ventilation indoor air quality (IAQ) control.
    - b. The IAQ sensor shall be available in duct mount, wall mount, or wall mount with LED display. The setpoint shall have adjustment capability.
  23. Smoke detectors (factory-installed only):
    - a. Shall be a Four-Wire Controller and Detector.
    - b. Shall be environmental compensated with differential sensing for reliable, stable, and drift-free sensitivity.
    - c. Shall use magnet-activated test/reset sensor switches.
    - d. Shall have tool-less connection terminal access.
    - e. Shall have a recessed momentary switch for testing and resetting the detector.
    - f. Controller shall include:
      - (1.) One set of normally open alarm initiation contacts for connection to an initiating device circuit on a fire alarm control panel.
      - (2.) Two Form-C auxiliary alarm relays for interface with rooftop unit or other equipment.
      - (3.) One Form-C supervision (trouble) relay to control the operation of the Trouble LED on a remote test/reset station.
      - (4.) Capable of direct connection to two individual detector modules.
      - (5.) Can be wired to up to 14 other duct smoke detectors for multiple fan shutdown applications
  24. Horn/Strobe Annunciator
    - a. Provides an audible/visual signaling device for use with factory-installed option or field-installed accessory smoke detectors.
      - (1.) Requires installation of a field-supplied 24-v transformer suitable for 4.2 VA (AC) or 3.0 VA (DC) per horn/strobe accessory.
      - (2.) Requires field-supplied electrical box, North American 1-gang box, 2-in (51 mm) x 4-in (102 mm).
      - (3.) Shall have a clear colored lens.
  25. Winter start kit
    - a. Shall contain a bypass device around the low pressure switch.
    - b. Shall be required when mechanical cooling is required down to 25°F (-4°C).
    - c. Shall not be required to operate on an economizer when below an outdoor ambient of 40°F (4°C).
  26. Time Guard
    - a. Shall prevent compressor short cycling by providing a 5-minute delay (±2 minutes) before restarting a compressor after shutdown for any reason.
    - b. One device shall be required per compressor.
  27. Condensate Overflow Switch (for units with electro-mechanical controls only):
    - a. This sensor and related controller monitors the condensate level in the drain pan and shuts down compression operation when overflow conditions occur. It includes
      - (1.) Indicator light – solid red (more than 10 seconds on water contact – compressors disabled), blinking red (sensor disconnected).
      - (2.) 10 second delay to break – eliminates nuisance trips from splashing or waves in pan (sensor needs 10 seconds of constant water contact before tripping).
      - (3.) Disables the compressor(s) operation when condensate plug is detected, but still allows fans to run for Economizer.
  28. Hinged Access Panels

- a. Shall provide easy access through integrated quarter turn latches.
  - b. Shall be on major panels of – filter, control box, fan motor and compressor
29. Display Kit for Variable Frequency Drive
- a. Kit allows the ability to access the VFD controller programs to provide special setup capabilities and diagnostics.
  - b. Kit contains display module and communication cable.
  - c. Display Kit can be permanently installed in the unit or used on any 2-Speed Indoor Fan Motor system VFD controller as needed.