

INSTALLATION INSTRUCTIONS

14 SEER Single-Packaged Dual Fuel System with R-410A Refrigerant Single Phase 2-5 Nominal Tons (Sizes 24-60) Three Phase 3-5 Nominal Tons (Sizes 36-60) PDD4, PDS4 Series E and G

IMPORTANT: Effective January 1, 2015, all split system and packaged air conditioners must be installed pursuant to applicable regional efficiency standards issued by the Department of Energy.

NOTE: Read the entire instruction manual before starting the installation.

NOTE: Installer: Make sure the Owner's Manual and Service Instructions are left with the unit after installation.

TABLE OF CONTENTS

	PAGE
SAFETY CONSIDERATIONS	1
INTRODUCTION	2
RECEIVING AND INSTALLATION	2-13
Check Equipment	2
Identify Unit	2
Inspect Shipment	2
Provide Unit Support	2
Roof Curb	2
Slab Mount	6
Field Fabricate Ductwork	6
Provide Clearances	6
Rig and Place Unit	6
Connect Condensate Drain	7
Install Flue Hood	7
Install Gas Piping	7
Install Duct Connections	8
Configuring Units for Downflow (Vertical)	
Discharge	8
Install Electrical Connections	12
High-Voltage Connections	12
Special Procedures for 208-V Operation	12
Control Voltage Connections	12
Balance Point Setting Thermostat or Hybrid Heat	
Thermostat	13
Transformer Protection	13
PRE-START-UP	13
START-UP	14-19
Check for Refrigerant Leaks	14
Unit Sequence of Operation	14
Start-Up Heating and Make Adjustments	15
Checking Heating Control	15
Check Gas Input	15
Adjust Gas Input	16
Check Burner Flame	16
Start-Up Cooling and Make Adjustments	17
Checking Cooling Control Operation	17
Checking and Adjusting Refrigerant	17
Indoor Airflow and Airflow Adjustments	18
Continuous Fan Operation	19
MAINTENANCE	48-51
Air Filter	48
Indoor Blower and Motor	48
Flue Gas Passageways	49
Limit Switch	49
Burner Ignition	49
Main Burners	49
Outdoor Coil, Indoor Coil, & Condensate Drain Pan	49

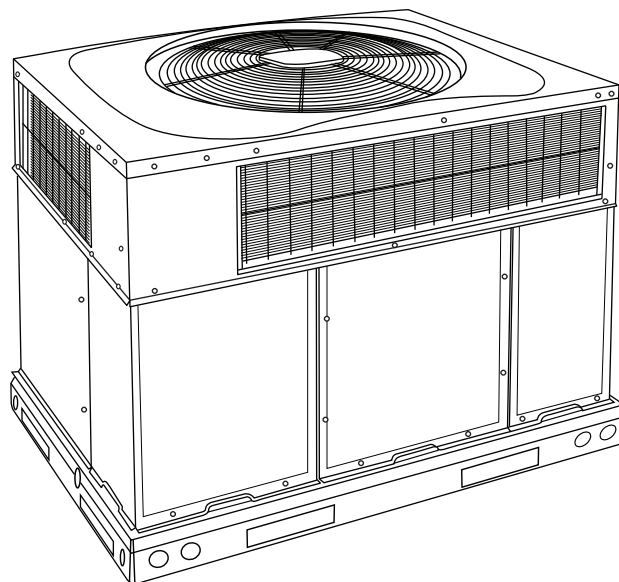

A09034

Fig. 1 - Unit PDD4, PDS4

Outdoor Fan	50
Electrical Controls and Wiring	50
Refrigerant Circuit	50
Gas Input	51
Indoor Airflow	51
Check Defrost Thermostat	51
R-410A Items	51
TROUBLESHOOTING	55
START-UP CHECKLIST	55

SAFETY CONSIDERATIONS

Improper installation, adjustment, alteration, service maintenance, or use can cause explosion, fire, electrical shock, or other conditions which may cause death, personal injury, or property damage. Consult a qualified installer, service agency, or your distributor or branch for information or assistance. The qualified installer or agency must use factory-authorized kits or accessories when modifying this product. Refer to the individual instructions packaged with the kits or accessories when installing.

Follow all safety codes. Wear safety glasses, protective clothing, and work gloves. Have a fire extinguisher available. Read these instructions thoroughly and follow all warnings or cautions included in literature and attached to the unit. Consult local building codes, the current editions of the National Fuel Gas Code (NFPA) NFPA 54/ANSI Z223.1, and the National Electrical Code (NEC) NFPA 70.

In Canada refer to the current editions of the National Standards of Canada CAN/CSA-B149.1 and .2 Natural Gas and Propane Installation codes, and Canadian Electrical Code CSA C22.1

Recognize safety information. This is the safety-alert symbol . When you see this symbol on the unit and in instructions or manuals, be alert to the potential for personal injury. Understand these signal words: DANGER, WARNING, and CAUTION. These

words are used with the safety-alert symbol. DANGER identifies the most serious hazards which **will** result in severe personal injury or death. WARNING signifies hazards which **could** result in personal injury or death. CAUTION is used to identify unsafe practices which **may** result in minor personal injury or product and property damage. NOTE is used to highlight suggestions which **will** result in enhanced installation, reliability, or operation.

⚠ WARNING

ELECTRICAL SHOCK HAZARD

Failure to follow this warning could result in personal injury or death.

Before installing or servicing system, always turn off main power to system and install lockout tag. There may be more than one disconnect switch. Turn off accessory heater power switch if applicable.

⚠ WARNING

FIRE, EXPLOSION, ELECTRICAL SHOCK AND CARBON MONOXIDE POISONING HAZARD

Failure to follow this warning could result in personal injury, death or property damage.

A qualified installer or agency must use only factory-authorized kits or accessories when modifying this product.

⚠ CAUTION

CUT HAZARD

Failure to follow this caution may result in personal injury.

When removing access panels (see Fig. 19) or performing maintenance functions inside your unit, be aware of sharp sheet metal parts and screws. Although special care is taken to reduce sharp edges to a minimum, be extremely careful and wear appropriate protective clothing, safety glasses and gloves when handling parts or reaching into the unit.

INTRODUCTION

This unit (see Fig. 1) is a fully self-contained, combination Category I gas heating/electric heating and cooling unit designed for outdoor installation (See Fig. 2 and 3 for unit dimensions). All unit sizes have return and discharge openings for both horizontal and downflow configurations, and are factory shipped with all downflow duct openings covered. Units may be installed either on a rooftop, a cement slab, or directly on the ground, if local codes permit (See Fig. 4 for roof curb dimensions).

In gas heating mode, this unit is designed for a minimum continuous return-air temperature of 55°F (13°C) db and a maximum continuous return-air temperature of 80°F (27°C) db. Failure to follow these return-air temperature limits may affect reliability of heat exchangers, motors, and other components.

Models that start with a “P” that are low Nox have a “1” in the 13th position, while units that start with a “W” have an “L” in the 11th position. These models are designed for California installations. These models meet the California maximum oxides of nitrogen (NOx) emissions requirements of 40 nanograms/joule or less as shipped from the factory and must be installed in California Air Quality Management Districts or any other regions in North America where a Low NOx rule exists.

RECEIVING AND INSTALLATION

Step 1 — Check Equipment

IDENTIFY UNIT

The unit model number and serial number are stamped on the unit information plate. Check this information against shipping papers.

INSPECT SHIPMENT

Inspect for shipping damage before removing packaging materials. If unit appears to be damaged or is torn loose from its anchorage, have it examined by transportation inspectors before removal. Forward claim papers directly to transportation company. Manufacturer is not responsible for any damage incurred in transit. Check all items against shipping list. Immediately notify the nearest equipment distribution office if any item is missing. To prevent loss or damage, leave all parts in original packages until installation.

If the unit is to be mounted on a curb in a downflow application, review Step 9 to determine which method is to be used to remove the downflow panels before rigging and lifting into place. The panel removal process may require the unit to be on the ground.

Step 2 — Provide Unit Support

For hurricane tie downs, contact distributor for details and PE (Professional Engineering) Certificate if required.

ROOF CURB

Install accessory roof curb in accordance with instructions shipped with curb (See Fig. 4). Install insulation, cant strips, roofing, and flashing. Ductwork must be attached to curb.

IMPORTANT: The gasketing of the unit to the roof curb is critical for a water tight seal. Install gasketing material supplied with the roof curb. Improperly applied gasketing also can result in air leaks and poor unit performance.

Curb should be level to within 1/4 in. (6 mm). This is necessary for unit drain to function properly. Refer to accessory roof curb installation instructions for additional information as required.

Installation on older “G” series roof curbs.

Two accessory kits are available to aid in installing a new “G” series unit on an old “G” roof curb.

1. Accessory kit number CPADCURB001A00, (small chassis) and accessory kit number CPADCURB002A00, (large chassis) includes roof curb adapter and gaskets for the perimeter seal and duct openings. No additional modifications to the curb are required when using this kit.
2. An alternative to the adapter curb is to modify the existing curb by removing the outer horizontal flange and use accessory kit number CPGSKTKIT001A00 which includes spacer blocks (for easy alignment to existing curb) and gaskets for the perimeter seal and duct openings. This kit is used when existing curb is modified by removing outer horizontal flange.

⚠ CAUTION

UNIT/STRUCTURAL DAMAGE HAZARD

Failure to follow this caution may result in property damage.

Ensure there is sufficient clearance for saw blade when cutting the outer horizontal flange of the roof curb so there is no damage to the roof or flashing.

UNIT	ELECTRICAL CHARACTERISTICS		UNIT WT.		UNIT HEIGHT		CENTER OF GRAVITY			
	LB	KG	"A"	"A"	X	Y	Z			
PDD/S14241C40/068/0/00/09/05/10/1/01	311	141.0	47-3/4	123	22-3/4	578	15-1/2	394	16-1/4	387
PDD/S14301C40/068/0/00/09/05/10/1/01	351	159.2	51-3/4	1315	22-3/4	578	15-1/2	394	16-1/4	387

UNITS	CORNER WEIGHT		"A"						
	"1"	"2"							
24	208/230	46.7	21.2	62.2	28.2	83.3	42.3	108.9	49.4
30	208/230	52.7	23.9	70.2	31.8	105.3	47.8	122.9	55.7

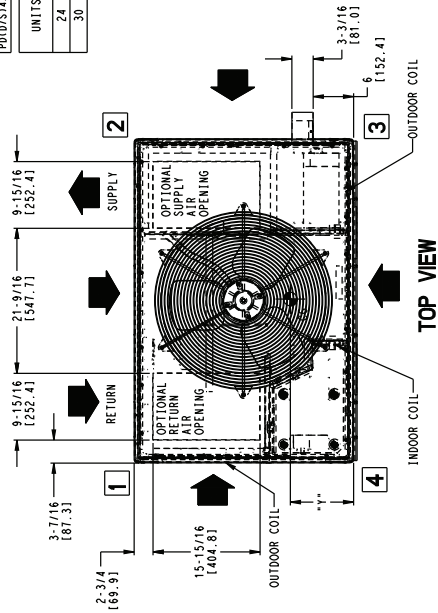

REQUIRED CLEARANCES TO COMBUSTIBLE MATL.

TOP OF UNIT.....17 [430.8]
DUCT SIDE OF UNIT.....2 [50.8]
SIDE OPPOSITE DUCTS.....14 [355.6]
BOTTOM OF UNIT.....1/2 [12.7]
FLUE PANEL.....36 [914.4]

NEC REQUIRED CLEARANCES:

BETWEEN UNITS, POWER ENTRY SIDE.....42 [1066.8]
UNIT AND INCLOSED SURFACES, ENTIRE SIDE.....36 [914.0]
UNIT AND INCLOSED SURFACES, POWER ENTRY SIDE.....42 [1066.8]

REQUIRED CLEARANCE FOR OPERATION AND SERVICING

EVAP. COIL ACCESS SIDE.....36 [914.0]
POWER ENTRY SIDE.....42 [1066.8]
(EXCEPT FOR NEC REQUIREMENTS)
UNIT TOP OPPOSITE DUCTS.....48 [1219.2]
UNIT BOTTOM OPPOSITE DUCTS.....12 [304.8]

*MINIMUM DISTANCES: IF UNIT IS PLACED LESS THAN 12 [304.8] FROM WALL SYSTEM, THEN SYSTEM PERFORMANCE MAYBE COMPROMISED.

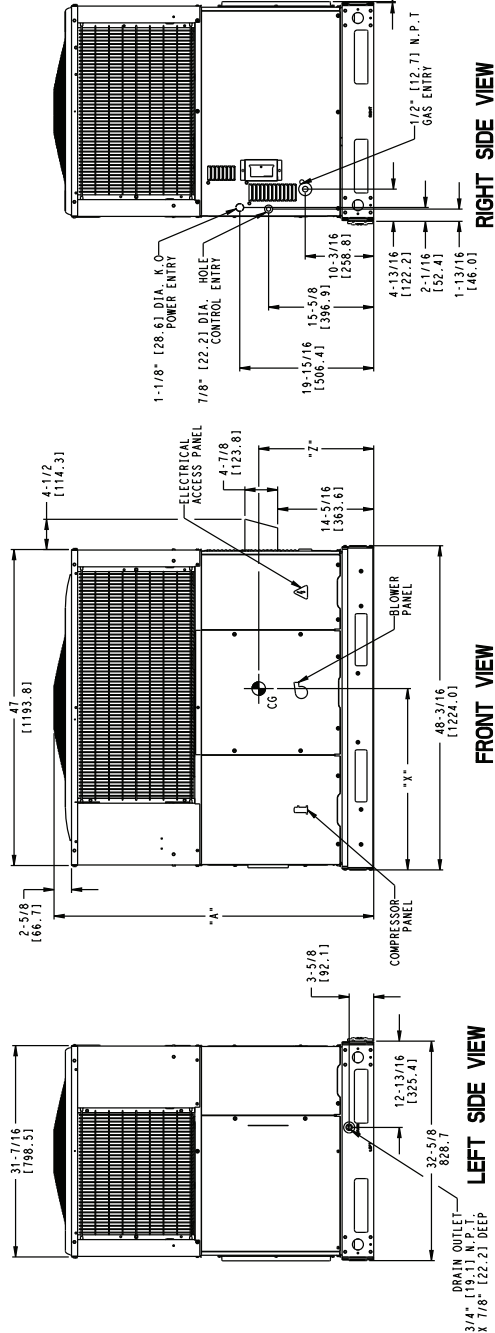

344804-4

Fig. 2 - 24-30 Unit Dimensions

A190141

UNIT	ELECTRICAL CHARACTERISTICS		UNIT WT.		UNIT HEIGHT IN/MM		CENTER OF GRAVITY IN/MM			
	LB	KG	"A"	"B"	"X"	"Z"				
PDD/S1436(060/090)K/H100/GP/GS10/1/G1	387	176.0	48-3/4	1238	22-3/4	518	18	457	17-1/8	435
PDD/S1442(060/090)K/H100/GP/GS10/1/G1	435	197.0	54-3/4	1391	22-3/4	518	18	457	17-3/8	435
PDD/S1448(090/115)130IK/H100/GP/GS10/1/G1	456	207.0	54-3/4	1391	22-3/4	518	18	457	17-3/8	435
PDD/S1460(090/115)130IK/H100/GP/GS10/1/G1	487	221.0	48-3/4	1238	22-3/4	518	18	457	17-3/4	435
PDD/S1436(060/090)K/H100/GP/GS10/1/E1	387	176.0	48-3/4	1238	22-3/4	518	18	457	17-1/8	435
PDD/S1442(060/090)K/H100/GP/GS10/1/E1	435	197.0	54-3/4	1391	22-3/4	518	18	457	17-3/8	435
PDD/S1448(090/115)130IK/H100/GP/GS10/1/E1	456	207.0	54-3/4	1391	22-3/4	518	18	457	17-3/8	435
PDD/S1460(090/115)130IK/H100/GP/GS10/1/E1	487	221.0	48-3/4	1238	22-3/4	518	18	457	17-3/4	435

UNIT	CORNER WEIGHT LB/KG								
	"1"	"2"	"3"	"4"					
36	208/230	58.1	26.3	77.4	35.1	116.1	52.7	135.5	61.4
42	208/230	65.3	29.6	87.0	39.5	130.5	59.2	152.3	69.1
48	208/230	68.4	31.0	91.2	41.4	136.8	62.1	159.6	72.4
60	208/230	73.1	33.1	97.4	44.2	146.1	66.3	170.5	77.3

REQUIRED CLEARANCES TO COMBUSTIBLE MATL.

	INCHES (MM)
TOP OF UNIT.....	14 (355.6)
DUCT SIDE OF UNIT.....	2 (50.8)
SIDE OPPOSITE DUCTS.....	14 (355.6)
BOTTOM OF UNIT.....	1/2 (12.7)
FLUE PANEL.....	36 (914.4)

NEC REQUIRED CLEARANCES

	INCHES (MM)
BETWEEN UNITS, POWER ENTRY SIDE.....	42 (1066.8)
UNIT AND UNGROUNDING SURFACES, POWER ENTRY SIDE.....	36 (914.4)
UNIT AND BLOCK OR CONCRETE WALLS AND OTHER GROUNDED SURFACES, POWER ENTRY SIDE.....	42 (1066.8)

REQUIRED CLEARANCE FOR OPERATION AND SERVICING

	INCHES (MM)
EVAP. COIL ACCESS SIDE.....	36 (914.4)
POWER ENTRY SIDE.....	42 (1066.8)
UNIT TOP FOR NEC REQUIREMENTS.....	48 (1219.2)
SIDE OPPOSITE DUCTS.....	36 (914.4)
DUCT PANEL.....	12 (304.8)

*MINIMUM DISTANCES-IF UNIT IS PLACED LESS THAN 12 (304.8) FROM WALL SYSTEM, THEN SYSTEM PERFORMANCE MAYBE COMPROMISED.

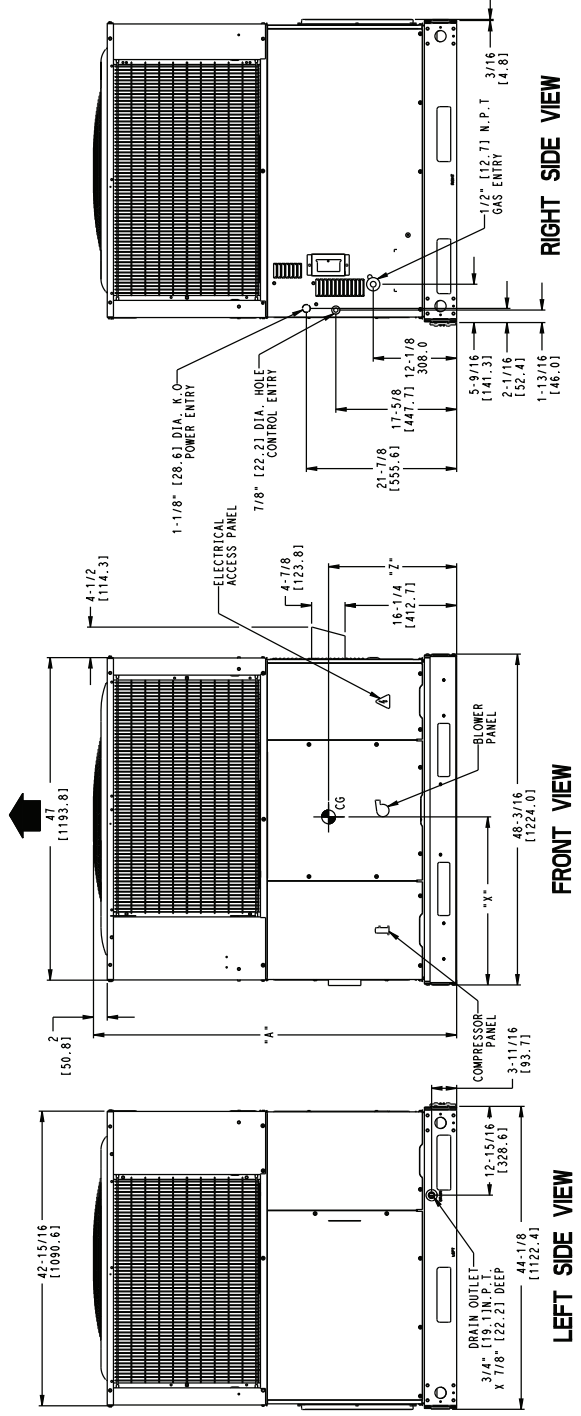
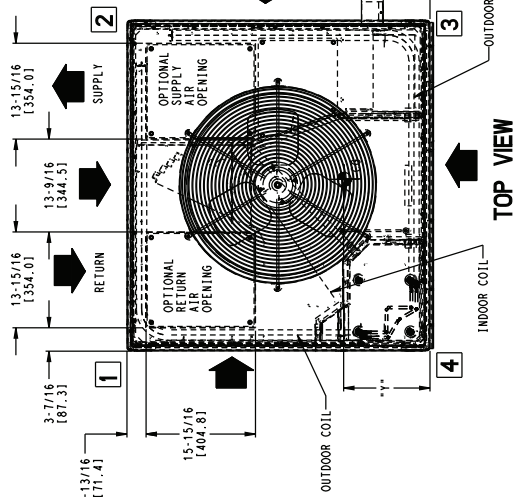

REAR VIEW

344813-4

Fig. 3 - 36-60 Unit Dimensions

A190142

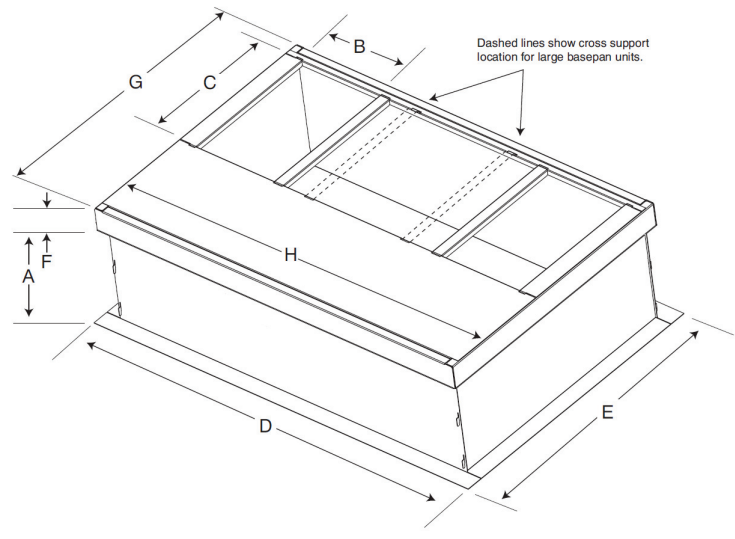
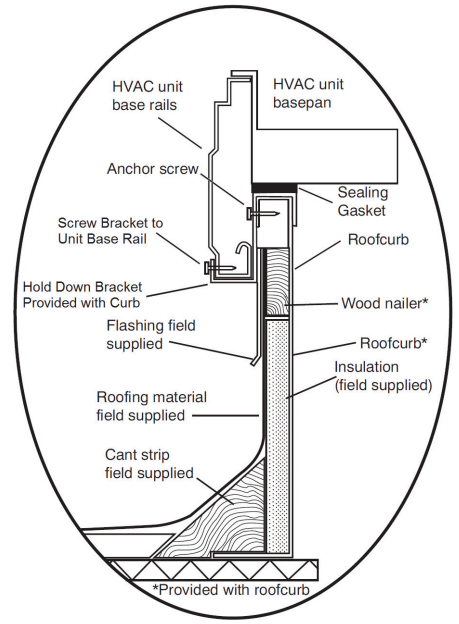

SMALL/COMMON CURB

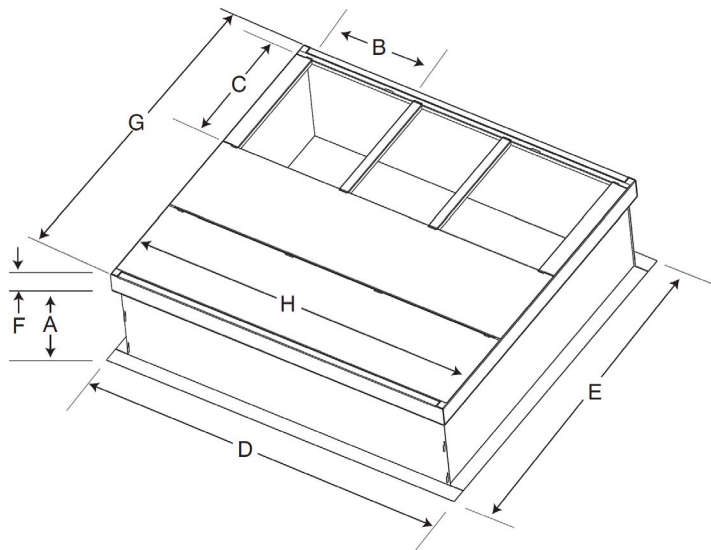

LARGE CURB

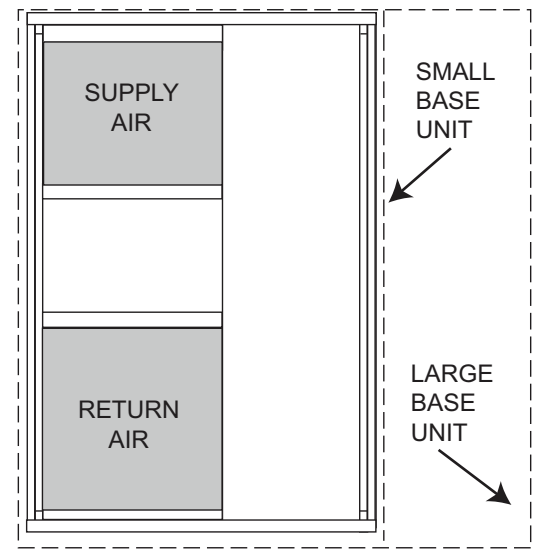

UNIT PLACEMENT ON COMMON CURB

SMALL OR LARGE BASE UNIT

A180216

UNIT SIZE	CATALOG NUMBER	A IN. (mm)	B IN. (mm)*	C IN. (mm)	D IN. (mm)	E IN. (mm)	F IN. (mm)	G IN. (mm)	H IN. (mm)
Small	CPRFCURB011B00	14 (356)	10 (254)	16 (406)	47.8 (1214)	32.4 (822)	2.7 (69)	30.6 (778)	46.1 (1170)
Large	CPRFCURB013B00	14 (356)	14 (356)			43.9 (1116)		42.2 (1072)	

NOTES:

1. Roof curb must be set up for unit being installed.
2. Seal strip must be applied, as required, to unit being installed.
3. Roof curb is made of 16-gauge steel.
4. Attach ductwork to curb (flanges of duct rest on curb).
5. Insulated panels: 1-in. (25.4 mm) thick fiberglass 1 lb. density.

IMPORTANT: Do not install large base pan HYBRID HEAT units onto the small base pan (common curb). The center of gravity on a large base pan HYBRID HEAT unit could overhang the curb causing an unsafe condition. Before installing any large base pan unit onto the common curb, check the “Y” distance in the product

literature dimensional drawing to ensure that “Y” is greater than 14 in. (356 mm). Do not install any large base pan unit onto the common curb with a “Y” dimension (center of gravity) less than 14 in. (356 mm).

Fig. 4 - Roof Curb Dimensions

⚠ CAUTION - NOTICE TO RIGGERS
⚠ PRUDENCE - AVIS AUX MANIPULATEUR

ACCESS PANELS MUST BE IN PLACE WHEN RIGGING.
 PANNEAUX D'ACCES DOIT ÊTRE EN PLACE POUR MANIPULATION.

Use top skid as spreader bar. / Utiliser la palette du haut comme barre de répartition

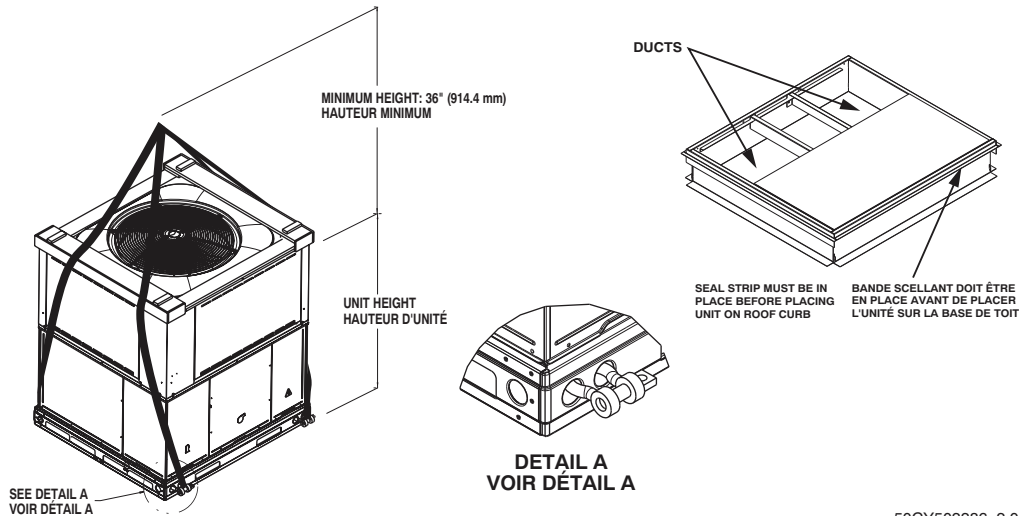

50CY502286 2.0

A09051

Unit	24		30		Unit	36		42		48		60	
	lb	kg	lb	kg		lb	kg	lb	kg	lb	kg	lb	kg
Rigging Weight	365	166	395	179	Rigging Weight	440	200	475	215	500	227	515	234

NOTE: See dimensional drawing for corner weight distribution.

Fig. 5 - Suggested Rigging

SLAB MOUNT

Place the unit on a solid, level pad that is at least 2 in. (51 mm) above grade. The pad should extend approximately 2 in. (51 mm) beyond the casing on all 4 sides of the unit. Do not secure the unit to the pad *except* when required by local codes.

Step 3 — Field Fabricate Ductwork

Secure all ducts to roof curb and building structure on vertical discharge units. Do not connect ductwork to unit. For horizontal applications, unit is provided with flanges on the horizontal openings. All ductwork should be secured to the flanges. Insulate and weatherproof all external ductwork, joints, and roof openings with counter flashing and mastic in accordance with applicable codes.

Ducts passing through an unconditioned space must be insulated and covered with a vapor barrier.

If a plenum return is used on a vertical unit, the return should be ducted through the roof deck to comply with applicable fire codes.

Read unit rating plate for any required clearances around ductwork. Cabinet return-air static shall not exceed -.25 IN. W.C.

Step 4 — Provide Clearances

The required minimum operating and service clearances are shown in Fig. 2 and 3.

IMPORTANT: Do not restrict outdoor airflow. An air restriction at either the outdoor-air inlet or the fan discharge may be detrimental to compressor life.

The condenser fan pulls air through the condenser coil and discharges it through the top grille. Be sure that the fan discharge does not recirculate to the condenser coil. Do not locate the unit in either a corner or under an overhead obstruction. The minimum clearance under a partial overhang (such as a normal house overhang) is 48-in. (1219 mm) above the unit top. The maximum horizontal extension of a partial overhang must not exceed 48-in. (1219 mm).

Do not place the unit where water, ice, or snow from an overhang or roof will damage or flood the unit. Do not install the unit on carpeting or other combustible materials. The unit may be installed on wood flooring or on Class A, B, or C roof covering materials.

Step 5 — Rig and Place Unit

⚠ WARNING

PERSONAL INJURY OR PROPERTY DAMAGE HAZARD

Failure to follow this warning could result in personal injury, death or property damage.

When installing the unit on a rooftop, be sure the roof will support the additional weight.

Rigging and handling of this equipment can be hazardous for many reasons due to the installation location (roofs, elevated structures, etc.).

Only trained, qualified crane operators and ground support staff should handle and install this equipment.

When working with this equipment, observe precautions in the literature, on tags, stickers, and labels attached to the equipment, and any other safety precautions that might apply.

Training for operators of the lifting equipment should include, but not be limited to, the following:

1. Application of the lifter to the load, and adjustment of the lifts to adapt to various sizes or kinds of loads.
2. Instruction in any special operation or precaution.
3. Condition of the load as it relates to operation of the lifting kit, such as balance, temperature, etc.

Follow all applicable safety codes. Wear safety shoes and work gloves.

Inspection

Prior to initial use, and at monthly intervals, all rigging shackles, clevis pins, and straps should be visually inspected for any damage, evidence of wear, structural deformation, or cracks. Particular attention should be paid to excessive wear at hoist hooking points and load support areas. Materials showing any kind of wear in these areas must not be used and should be discarded.

⚠ WARNING

UNIT FALLING HAZARD

Failure to follow this warning could result in personal injury or death.

Never stand beneath rigged units or lift over people.

⚠ WARNING

PROPERTY DAMAGE HAZARD

Failure to follow this warning could result in personal injury/death or property damage.

When straps are taut, the clevis should be a minimum of 36 in. (914 mm) above the unit top cover.

Rigging/Lifting of Unit (See Fig. 5)

Lifting holes are provided in base rails as shown in Fig. 2 and 3.

1. Leave top shipping skid on the unit for use as a spreader bar to prevent the rigging straps from damaging the unit. If the skid is not available, use a spreader bar of sufficient length to protect the unit from damage.
2. Attach shackles, clevis pins, and straps to the base rails of the unit. Be sure materials are rated to hold the weight of the unit (See Fig. 5).
3. Attach a clevis of sufficient strength in the middle of the straps. Adjust the clevis location to ensure unit is lifted level with the ground.

After the unit is placed on the roof curb or mounting pad, remove the top skid.

Step 6 — Connect Condensate Drain

NOTE: When installing condensate drain connection be sure to comply with local codes and restrictions.

Unit disposes of condensate water through a 3/4 in. NPT fitting which exits through the compressor access panel (See Fig. 2 and 3 for location).

Condensate water can be drained directly onto the roof in rooftop installations (where permitted) or onto a gravel apron in ground level installations. Install a field-supplied condensate trap at end of condensate connection to ensure proper drainage. Make sure that the outlet of the trap is at least 1 in. (25 mm) lower than the drain-pan condensate connection to prevent the pan from overflowing (See Fig. 6). Prime the trap with water. When using a gravel apron, make sure it slopes away from the unit.

If the installation requires draining the condensate water away from the unit, install a 2-in. (51 mm) trap at the condensate connection to ensure proper drainage (See Fig. 6). Make sure that

the outlet of the trap is at least 1 in. (25 mm) lower than the drain-pan condensate connection. This prevents the pan from overflowing.

Prime the trap with water. Connect a drain tube - using a minimum of 3/4-in. PVC or 3/4-in. copper pipe (all field-supplied) - at the outlet end of the 2-in. (51 mm) trap. Do not undersize the tube. Pitch the drain tube downward at a slope of at least 1-in. (25 mm) for every 10 ft (3 m) of horizontal run. Be sure to check the drain tube for leaks.

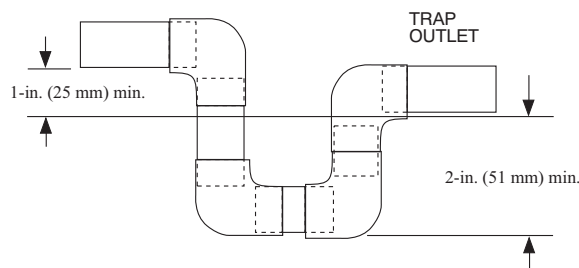

A09052

Fig. 6 - Condensate Trap

Step 7 — Install Flue Hood

The flue assembly is secured and shipped in the return air duct. Remove duct cover to locate the assembly (See Fig. 8).

NOTE: Dedicated low NOx models **MUST** be installed in California Air Quality Management Districts where a Low NOx rule exists.

These models meet the California maximum oxides of nitrogen (NOx) emissions requirements of 40 nanograms/joule or less as shipped from the factory.

NOTE: Low NOx requirements apply only to natural gas installations.

⚠ WARNING

CARBON MONOXIDE POISONING HAZARD

Failure to follow this warning could result in personal injury or death.

The venting system is designed to ensure proper venting. The flue hood assembly must be installed as indicated in this section of the unit installation instructions.

Install the flue hood as follows:

1. This installation must conform with local building codes and with the National Fuel Gas Code (NFGC) NFPA 54 / ANSI Z223.1, (in Canada, CAN/CSA B149.1, and B149.2) latest revision. Refer to Provincial and local plumbing or wastewater codes and other applicable local codes.
2. Remove flue hood from shipping location (inside the return section of the blower compartment-see Fig. 8). Remove the return duct cover to locate the flue hood. Place flue hood assembly over flue panel. Orient screw holes in flue hood with holes in the flue panel.
3. Secure flue hood to flue panel by inserting a single screw on the top flange and the bottom flange of the hood.

Step 8 — Install Gas Piping

The gas supply pipe enters the unit through the access hole provided. The gas connection to the unit is made to the 1/2-in. (12.7 mm) FPT gas inlet on the gas valve.

Install a gas supply line that runs to the heating section. Refer to Table 2 and the NFGC for gas pipe sizing. Do not use cast-iron pipe. It is recommended that a black iron pipe is used. Check the local utility for recommendations concerning existing lines. Size

PDD4, PDS4

gas supply piping for 0.5 IN. W.C. maximum pressure drop. Never use pipe smaller than the 1/2-in. (12.7 mm) FPT gas inlet on the unit gas valve.

For natural gas applications, the gas pressure at unit gas connection must not be less than 4.0 IN. W.C. or greater than 13 IN. W.C. while the unit is operating. For propane applications, the gas pressure must not be less than 11.0 IN. W.C. or greater than 13 IN. W.C. at the unit connection.

A 1/8-in. (3.2 mm) NPT plugged tapping, accessible for test gauge connection, must be installed immediately upstream of the gas supply connection to the gas valve.

When installing the gas supply line, observe local codes pertaining to gas pipe installations. Refer to the NFGC NFPA 54/ANSI Z223.1 latest edition (in Canada, CAN/CSA B149.1).

NOTE: In the state of Massachusetts:

1. Gas supply connections **MUST** be performed by a licensed plumber or gas fitter.
2. When flexible connectors are used, the maximum length shall not exceed 36 in. (915 mm).
3. When lever handle type manual equipment shutoff valves are used, they shall be T-handle valves.
4. The use of copper tubing for gas piping is **NOT** approved by the state of Massachusetts.

In the absence of local building codes, adhere to the following pertinent recommendations:

1. Avoid low spots in long runs of pipe. Grade all pipe 1/4 in. (6.35 mm) for every 15 ft (4.6 m) of length to prevent traps. Grade all horizontal runs downward to risers. Use risers to connect to heating section and to meter.
2. Protect all segments of piping system against physical and thermal damage. Support all piping with appropriate straps, hangers, etc. Use a minimum of one hanger every 6 ft (1.8 m). For pipe sizes larger than 1/2 in., (12.7 mm) follow recommendations of national codes.
3. Apply joint compound (pipe dope) sparingly and only to male threads of joint when making pipe connections. Use only pipe dope that is resistant to action of liquefied petroleum gases as specified by local and/or national codes. Never use Teflon tape.
4. Install sediment trap in riser leading to heating section (See Fig. 7). This drip leg functions as a trap for dirt and condensate.

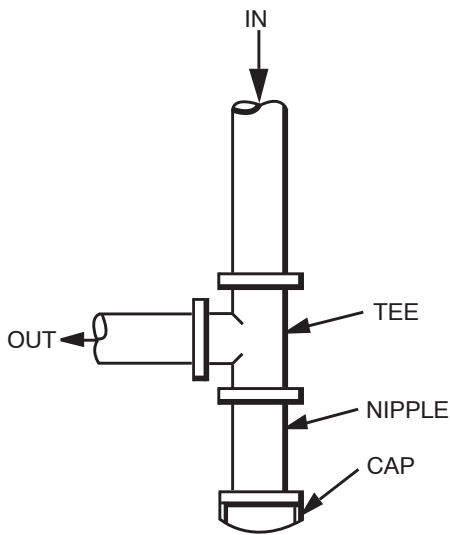

Fig. 7 - Sediment Trap

C99020

5. Install an accessible, external, manual main shutoff valve in gas supply pipe within 6 ft (1.8 m) of heating section.
6. Install ground-joint union close to heating section between unit manual shutoff and external manual main shut-off valve.
7. Pressure test all gas piping in accordance with local and national plumbing and gas codes before connecting piping to unit.

NOTE: Pressure test the gas supply system after the gas supply piping is connected to the gas valve. The supply piping must be disconnected from the gas valve during the testing of the piping systems when test pressure is in excess of 0.5 psig. Pressure test the gas supply piping system at pressures equal to or less than 0.5 psig. The unit heating section must be isolated from the gas piping system by closing the external main manual shutoff valve and slightly opening the ground-joint union.

⚠ **WARNING**

FIRE OR EXPLOSION HAZARD

Failure to follow this warning could result in personal injury, death and/or property damage.

-Connect gas pipe to unit using a backup wrench to avoid damaging gas controls.

-Never purge a gas line into a combustion chamber. Never test for gas leaks with an open flame. Use a commercially available soap solution made specifically for the detection of leaks to check all connections. A fire or explosion may result causing property damage, personal injury or loss of life.

-Use proper length of pipe to avoid stress on gas control manifold.

-If a flexible connector is required or allowed by authority having jurisdiction, black iron pipe shall be installed at furnace gas valve and extend a minimum of 2 in. (51 mm) outside furnace casing.

-If codes allow a flexible connector, always use a new connector. do not use a connector which has previously serviced another gas appliance.

8. Check for gas leaks at the field-installed and factory-installed gas lines after all piping connections have been completed. Use a commercially available soap solution made specifically for the detection of leaks (or method specified by local codes and/or regulations).

Step 9 — Install Duct Connections

The unit has duct flanges on the supply- and return-air openings on the side and bottom of the unit. For downshot applications, the ductwork connects to the roof curb (See Fig. 2 and 3 for connection sizes and locations).

Configuring Units for Downflow (Vertical) Discharge

⚠ **WARNING**

ELECTRICAL SHOCK HAZARD

Failure to follow this warning could result in personal injury or death.

Before installing or servicing system, always turn off main power to system and install lockout tag. There may be more than one disconnect switch.

1. Open all electrical disconnects before starting any service work.
2. Remove horizontal (metal) duct covers to access vertical (downflow) discharge duct knockouts in unit basepan. (See Fig. 8.)

⚠ CAUTION

PROPERTY DAMAGE HAZARD

Failure to follow this caution may result in property damage. Collect ALL screws that were removed. **Do not** leave screws on rooftop as permanent damage to the roof may occur.

3. For single-phase models only, on the discharge side only, remove the insulation covering the downshot (plastic) knockout. Insulation is held in place with aluminum tape. Please note that large chassis units have 2 pieces of insulation, and only the piece over the downshot knockout needs to be removed. Discard insulation.
4. To remove the downshot (plastic) knockouts for both supply and returns, break front and right side connecting tabs with a screwdriver and hammer. Push cover down to break rear and left side tabs. These plastic knockouts are held in place with tabs similar to an electrical knockout. Discard plastic knockout covers.
5. Set unit on roof curb.
6. Verify that the downshot ducts are aligned with the downshot knockout areas.
7. Re-install horizontal (metal) covers as needed to seal unit. Ensure openings are air and watertight.

NOTE: The design and installation of the duct system must be in accordance with the standards of the NFPA for installation of nonresidence-type air conditioning and ventilating systems, NFPA 90A or residence-type, NFPA 90B; and/or local codes and ordinances.

Adhere to the following criteria when selecting, sizing, and installing the duct system:

1. Units are shipped for horizontal duct installation (by removing duct covers).
2. Select and size ductwork, supply-air registers, and return-air grilles according to American Society of Heating, Refrigeration and Air Conditioning Engineers (ASHRAE) recommendations.
3. Use flexible transition between rigid ductwork and unit to prevent transmission of vibration. The transition may be screwed or bolted to duct flanges. Use suitable gaskets to ensure weather tight and airtight seal.
4. All units must have field-supplied filters or accessory filter rack installed in the return-air side of the unit. Recommended sizes for filters are shown in Table 1.

5. Size all ductwork for maximum required airflow (either heating or cooling) for unit being installed. Avoid abrupt duct size increases or decreases or performance may be affected.
6. Adequately insulate and weatherproof all ductwork located outdoors. Insulate ducts passing through unconditioned space, and use vapor barrier in accordance with latest issue of Sheet Metal and Air Conditioning Contractors National Association (SMACNA) and Air Conditioning Contractors of America (ACCA) minimum installation standards for heating and air conditioning systems. Secure all ducts to building structure.
7. Flash, weatherproof, and vibration-isolate all openings in building structure in accordance with local codes and good building practices.

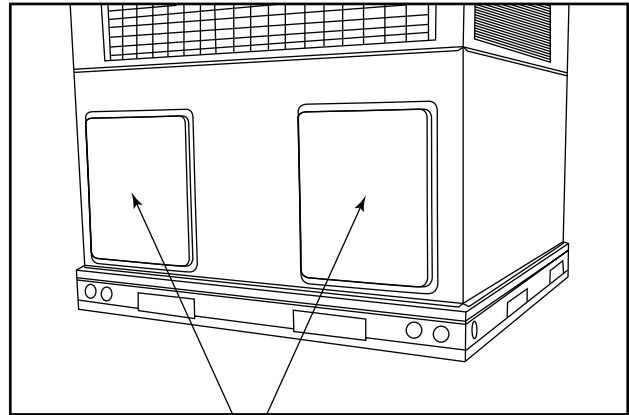

Horizontal Duct Covers

A09061

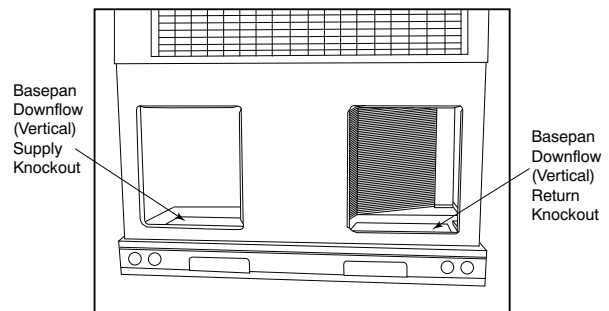

A09088

Fig. 8 - Supply and Return Duct Opening

Table 1 – Physical Data

Unit Size	24040	24060	30040	30060	36060	36090
Nominal Capacity – ton	2	2	2.5	2.5	3	3
Shipping Weight (lb) (kg)	365 166	365 166	395 179	395 179	440 200	440 200
Compressor / Quantity	Scroll / 1					
Refrigerant	R-410A					
Refrigerant Quantity (lb) Quantity (kg)	7.5 3.4	7.5 3.4	9.0 4.1	9.0 4.1	8.9 4.0	8.9 4.0
Refrigerant Metering Device	Indoor TXV, Outdoor Dual Accuraters					
Orifice OD (in) (mm)	0.032 (2) 0.81 (2)	0.032 (2) 0.81 (2)	0.035 (2) 0.89 (2)	0.035 (2) 0.89 (2)	0.040 (2) 1.02 (2)	0.040 (2) 1.02 (2)
Outdoor Coil Rows... Fins/in, face area (sq. ft.)	1...21 15.4	1...21 15.4	1...21 18.8	1...21 18.8	1...21 17.5	1...21 17.5
Outdoor Fan Nominal Airflow (cfm) Diameter (in.) Diameter (mm) Motor hp (rpm)	2500 24 610 1/12 (810)	2500 24 610 1/12 (810)	3000 24 610 1/10 (810)	3000 24 610 1/10 (810)	3500 26 660 1/5 (810)	3500 26 660 1/5 (810)
Indoor Coil Rows... Fins/in, face area (sq. ft.)	3...17 3.7	3...17 3.7	3...17 3.7	3...17 3.7	2...15 5.6	2...17 5.6
Indoor Blower Nominal Airflow (cfm) Size (in.) Size (mm) Motor hp	800 10 x 10 254 x 254 1/2	800 10 x 10 254 x 254 1/2	1000 10 x 10 254 x 254 1/2	1000 10 x 10 254 x 254 1/2	1200 11 x 10 279 x 254 1/2	1200 11 x 10 279 x 254 1/2
Furnace Section* Burner Orifice 1-Phase Natural Gas Qty...Drill Size 1-Phase Propane Gas Qty...Drill Size 3-Phase Natural Gas Qty...Drill Size 3-Phase Propane Gas Qty...Drill Size	2...44 2...55 2...44 2...55	3...44 3...55 2...38 2...53	2...44 2...55 2...44 2...55	3...44 3...55 2...38 2...53	3...44 3...55 2...38 2...53	3...38 3...53 3...38 3...53
High Pressure Switch (psig) Cutout Reset (Auto)	650 +/- 15 420 +/- 25					
Loss-of-Charge/Low Pressure Switch (psig) Cutout Reset (Auto)	20 +/- 5 45 +/- 10					
Return Air Filters†‡ disposable	2 each 20x12x1 in. 508x305x25 mm				1 each 24x16x1 in. 610x406x25 mm 24x18x1 in. 510x457x25 mm	

*Based on altitude of 0 to 2000 ft (0–610 m).

†Required filter sizes shown are based on the larger of the AHRI (Air Conditioning Heating and Refrigeration Institute) rated cooling airflow or the heating airflow velocity of 300 to 350 ft/minute for high-capacity type. Air filter pressure drop for non-standard filters must not exceed 0.08 IN. W.C.

‡ If using accessory filter rack refer to filter rack installation instructions for correct filter size and quantity.

PDD4, PDS4

Table 1 - Physical Data Cont'd

Unit Size	42060	42090	48090	48115	48130	60090	60115	60130
Nominal Capacity – ton	3.5	3.5	4	4	4	5	5	5
Shipping Weight (lb) (kg)	475 215	475 215	500 227	500 227	500 227	515 234	515 234	515 234
Compressor / Quantity	Scroll / 1							
Refrigerant	R-410A							
Refrigerant Quantity (lb) Quantity (kg)	11.2 5.1	11.2 5.1	9.9 4.5	9.9 4.5	9.9 4.5	11.9 5.4	11.9 5.4	11.9 5.4
Refrigerant Metering Device	Indoor TXV, Outdoor Dual Accuraters		Indoor Accurater, Outdoor Dual Accuraters			Indoor TXV, Outdoor Dual Accuraters		
Orifice ID (in) (mm)	N/A		0.080 (1) 2.03 (1)			N/A		
Orifice OD (in) (mm)	0.046 (2) 1.17 (2)	0.046 (2) 1.17 (2)	0.046 (2) 1.17 (2)	0.046 (2) 1.17 (2)	0.046 (2) 1.17 (2)	0.052 (2) 1.32 (2)	0.052 (2) 1.32 (2)	0.052 (2) 1.32 (2)
Outdoor Coil Rows... Fins/in, face area (sq. ft.)	1...21 23.3	1...21 23.3	1...21 23.3	1...21 23.3	1...21 23.3	2...21 17.5	2...21 17.5	2...21 17.5
Outdoor Fan Nominal Airflow (cfm) Diameter (in.) Diameter (mm) Motor hp Motor (rpm)	3500 26 660 1/5 (810)	3500 26 660 1/5 (810)	3500 26 660 1/5 (810)	3500 26 660 1/5 (810)	3500 26 660 1/5 (810)	3500 26 660 1/4 (810)	3500 26 660 1/4 (810)	3500 26 660 1/4 (810)
Indoor Coil Rows... Fins/in, face area (sq. ft.)	3...17 4.7	3...17 4.7	3...17 4.7	3...17 4.7	3...17 4.7	3...17 5.6	3...17 5.6	3...17 5.6
Indoor Blower Nominal Airflow (cfm) Size (in.) Size (mm) Motor hp	1350 11 x 10 279 x 254 1/2	1350 11 x 10 279 x 254 1/2	1600 11 x 10 279 x 254 1	1600 11 x 10 279 x 254 1	1600 11 x 10 279 x 254 1	1750 11 x 10 279 x 254 1	1750 11 x 10 279 x 254 1	1750 11 x 10 279 x 254 1
Furnace Section* Burner Orifice 1 Phase Natural Gas Qty...Drill Size 1 Phase Propane Gas Qty...Drill Size 3 Phase Natural Gas Qty...Drill Size 3 Phase Propane Gas Qty...Drill Size	3...44 3...55 2...38 2...53	3...38 3...53 3...38 3...53	3...38 3...53 3...38 3...53	3...33 3...51 3...33 3...51	3...31 3...49 3...31 3...49	3...38 3...53 3...38 3...53	3...33 3...51 3...33 3...51	3...31 3...49 3...31 3...49
High Pressure Switch (psig) Cutout Reset (Auto)	650 +/- 15 420 +/- 25							
Loss-of-Charge/Low Pressure Switch (psig) Cutout Reset (Auto)	20 +/- 5 45 +/- 10							
Return Air Filters†‡ disposable	1 each 24x14x1 (610x356x25) 24x15x1 (610x406x25)					1 each 24x16x1 (610x406x25) 24x18x1 (610x457x25)		

*Based on altitude of 0 to 2000 ft (0-610 m).

†Required filter sizes shown are based on the larger of the AHRI (Air Conditioning Heating and Refrigeration Institute) rated cooling airflow or the heating airflow velocity of 300 to 350 ft/minute for high –capacity type. Air filter pressure drop for non –standard filters must not exceed 0.08 IN. W.C.

‡ If using accessory filter rack refer to filter rack installation instructions for correct filter size and quantity.

Table 2 – Maximum Gas Flow Capacity*

NOMINAL IRON PIPE, SIZE (IN.)	INTERNAL DIAMETER (IN.)	LENGTH OF PIPE, FT (m)†													
		10 (3.0)	20 (6.1)	30 (9.1)	40 (12.2)	50 (15.2)	60 (18.3)	70 (21.3)	80 (24.4)	90 (27.4)	100 (30.5)	125 (31.1)	150 (45.7)	175 (53.3)	200 (61.0)
1/2	.622	175	120	97	82	73	66	61	57	53	50	44	40	—	—
3/4	.824	360	250	200	170	151	138	125	118	110	103	93	84	77	72
1	1.049	680	465	375	320	285	260	240	220	205	195	175	160	145	135
1 –1/4	1.380	1400	950	770	600	580	530	490	460	430	400	360	325	300	280
1 –1/2	1.610	2100	1460	1180	990	900	810	750	690	650	620	550	500	460	430

* Capacity of pipe in cu ft of gas per hr for gas pressure of 0.5 psig or less. Pressure drop of 0.5-IN. W.C. (based on a 0.60 specific gravity gas). Refer to Table 2 and the NFGC NFPA 54/ANSI Z 223.1.

† This length includes an ordinary number of fittings.

Table 3 – Heating Inputs

HEATING INPUT (BTUH)	NUMBER OF ORIFICES	GAS SUPPLY PRESSURE (IN. W.C.)				MANIFOLD PRESSURE (IN. W.C.)	
		Natural†		Propane*†		Natural†	Propane*†
		Min	Max	Min	Max		
40,000	2	4.0	13.0	11.0	13.0	3.2-3.8	10.0-11.0
60,000	3	4.0	13.0	11.0	13.0	3.2-3.8	10.0-11.0
90,000	3	4.5	13.0	11.0	13.0	3.2-3.8	10.0-11.0
115,000	3	4.5	13.0	11.0	13.0	3.2-3.8	10.0-11.0
130,000	3	4.5	13.0	11.0	13.0	3.2-3.8	10.0-11.0

*When a unit is converted to propane, different size orifices must be used. See separate, natural –to–propane conversion kit instructions.

†Based on altitudes from sea level to 2000 ft (610 m) above sea level. In the U.S.A. for altitudes above 2000 ft (610 m), reduce input rating 4 percent for each additional 1000 ft (305 m) above sea level. In Canada, from 2000 ft (610 m) above sea level to 4500 ft (1372 m) above sea level, derate the unit 10 percent.

PDD4, PDS4

Step 10 — Install Electrical Connections

WARNING

ELECTRICAL SHOCK HAZARD

Failure to follow this warning could result in personal injury or death.

The unit cabinet must have an uninterrupted, unbroken electrical ground. This ground may consist of an electrical wire connected to the unit ground screw in the control compartment, or conduit approved for electrical ground when installed in accordance with NEC, NFPA 70 National Fire Protection Association (latest edition) (in Canada, Canadian Electrical Code CSA C22.1) and local electrical codes.

CAUTION

UNIT COMPONENT DAMAGE HAZARD

Failure to follow this caution may result in damage to the unit being installed.

1. Make all electrical connections in accordance with NEC NFPA 70 (latest edition) and local electrical codes governing such wiring. In Canada, all electrical connections must be in accordance with CSA standard C22.1 Canadian Electrical Code Part 1 and applicable local codes. Refer to unit wiring diagram.
2. Use only copper conductor for connections between field-supplied electrical disconnect switch and unit. **DO NOT USE ALUMINUM WIRE.**
3. Be sure that high-voltage power to unit is within operating voltage range indicated on unit rating plate. On 3-phase units, ensure phases are balanced within 2 percent. Consult local power company for correction of improper voltage and/or phase imbalance.
4. Insulate low-voltage wires for highest voltage contained within conduit when low-voltage control wires are in same conduit as high-voltage wires.
5. Do not damage internal components when drilling through any panel to mount electrical hardware, conduit, etc.

High-Voltage Connections

When routing power leads into unit, use only copper wire between disconnect and unit. The high voltage leads should be in a conduit until they enter the duct panel; conduit termination at the duct panel must be watertight.

The unit must have a separate electrical service with a field-supplied, waterproof disconnect switch mounted at, or within sight from, the unit. Refer to the unit rating plate, NEC and local codes for maximum fuse/circuit breaker size and minimum circuit amps (ampacity) for wire sizing.

The field-supplied disconnect switch box may be mounted on the unit over the high-voltage inlet hole when the standard power and low-voltage entry points are used (See Fig. 2 and 3 for acceptable location).

NOTE: Field supplied disconnect switch box should be positioned so that it does not cover up any of the unit gas combustion supply air louvers.

See unit wiring label (Fig. 15 and 16) and Fig. 9 for reference when making high voltage connections. Proceed as follows to complete the high-voltage connections to the unit.

Single phase units:

1. Run the high-voltage (L1, L2) and ground lead into the control box.
2. Connect ground lead to chassis ground connection.

3. Locate the black and yellow wires connected to the line side of the contactor.
4. Connect field L1 to black wire on connection 11 of the compressor contactor.
5. Connect field wire L2 to yellow wire on connection 23 of the compressor contactor.

Three-phase units:

1. Run the high-voltage (L1, L2, L3) and ground lead into the control box.
2. Connect ground lead to chassis ground connection.
3. Locate the black and yellow wires connected to the line side of the contactor.
4. Connect field L1 to black wire on connection 11 of the compressor contactor.
5. Connect field wire L3 to yellow wire on connection 13 of the compressor contactor.
6. Connect field wire L2 to blue wire from compressor.

Special Procedures for 208-V Operation

WARNING

ELECTRICAL SHOCK HAZARD

Failure to follow this warning could result in personal injury or death.

Make sure the power supply to the unit is switched OFF before making any wiring changes. Tag the disconnect switch with a suitable warning label. With disconnect switch open, move black wire from transformer (3/16 in.) terminal marked 230 to terminal marked 200. This retaps transformer to primary voltage of 208 vac.

WARNING

ELECTRICAL SHOCK HAZARD

Failure to follow this warning could result in personal injury or death.

Before making any wiring changes, **make sure** the gas supply is switched off first. *Then* switch off the power supply to the unit and install lockout tag.

Control Voltage Connections

Do not use any type of power-stealing thermostat. Unit control problems may result.

Use no. 18 American Wire Gage (AWG) color-coded, insulated (35°C minimum) wires to make the control voltage connections between the thermostat and the unit. If the thermostat is located more than 100 ft (30.5 m) from the unit (as measured along the control voltage wires), use no. 16 AWG color-coded, insulated (35°C minimum) wires.

Locate the seven (eight on 3-phase) low voltage thermostat leads in 24 volt splice box. See Fig. 9 for connection diagram. Run the low-voltage leads from the thermostat, through the control wiring inlet hole grommet (Fig. 2 and 3), and into the low-voltage splice box. Provide a drip loop before running wires through panel. Secure and strain relief all wires so that they do not interfere with operation of unit. A gray wire is standard on 3-phase unit for connection to an economizer.

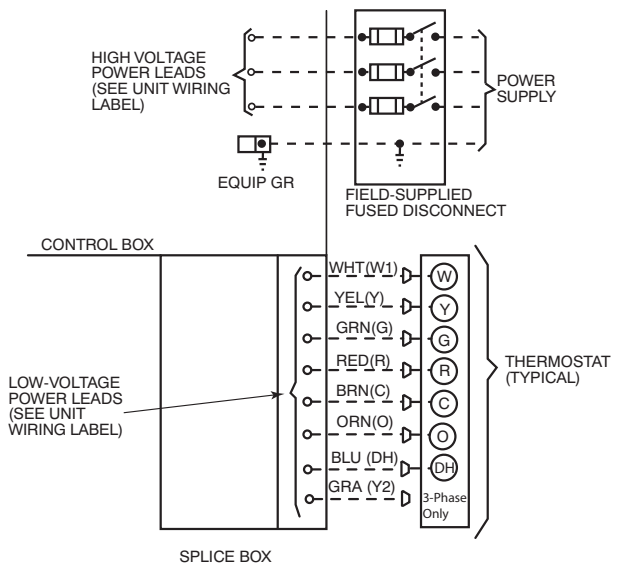

Fig. 9 - High and Control-Voltage Connections

Balance Point Setting-Thermidstat or Hybrid Thermostat

BALANCE POINT TEMPERATURE-The “balance point” temperature is a setting which affects the operation of the heating mode. This is a field-selected input temperature (range 5 to 55°F) (-15 to 12°C) where the Thermidstat or dual fuel thermostat will monitor outdoor air temperature and decide whether to enable or disable the heat pump. If the outdoor temperature is above the “balance point”, the heat pump will energize first to try to satisfy the indoor temperature demand. If the heat pump does not make a sufficient improvement within a reasonable time period (i.e. 15 minutes), then the gas furnace will come on to satisfy the indoor temperature demand. If the outdoor temperature is below the “balance point”, the heat pump will not be allowed to operate (i.e. locked out), and the gas furnace will be used to satisfy the indoor temperature. There are three separate concepts which are related to selecting the final “balance point” temperature. Read each of the following carefully to determine the best “balance point” in a hybrid installation:

1. Capacity Balance Temperature: This is a point where the heat pump cannot provide sufficient capacity to keep up with the indoor temperature demand because of declining outdoor temperature. At or below this point, the furnace is needed to maintain proper indoor temperature.
2. Economic Balance Temperature: Above this point, the heat pump is the most cost efficient to operate, and below this point the furnace is the most cost efficient to operate. This can be somewhat complicated to determine and it involves knowing the cost of gas and electricity, as well as the efficiency of the furnace and heat pump. For the most economical operation, the heat pump should operate above this temperature (assuming it has sufficient capacity) and the furnace should operate below this temperature.
3. Comfort Balance Temperature: When the heat pump is operating below this point, the indoor supply air feels uncomfortable (i.e. too cool). This is purely subjective and will depend on the homeowner’s idea of comfort. Below this temperature the gas furnace should operate in order to satisfy the desire for indoor comfort.

Transformer Protection

The transformer is of the energy-limiting type. It is set to withstand a 30-sec. overload or shorted secondary condition. If an overload or short is present, correct overload condition and check for blown fuse on gas control board or Interface Fan Board. Replace fuse as required with correct size and rating.

PRE-START-UP

⚠ WARNING

FIRE, EXPLOSION, ELECTRICAL SHOCK HAZARD

Failure to follow this warning could result in personal injury, death or property damage.

1. Follow recognized safety practices and wear protective goggles when checking or servicing refrigerant system.
2. Do not operate compressor or provide any electric power to unit unless compressor terminal cover is in place and secured.
3. Do not remove compressor terminal cover until all electrical sources are disconnected and tagged.
4. Relieve and recover all refrigerant from system before touching or disturbing anything inside terminal box if refrigerant leak is suspected around compressor terminals.
5. Never attempt to repair soldered connection while refrigerant system is under pressure.
6. Do not use torch to remove any component. System contains oil and refrigerant under pressure. To remove a component, wear protective goggles and proceed as follows:
 - a. Shut off electrical power to unit and install lockout tag.
 - b. Relieve and reclaim all refrigerant from system using both high- and low-pressure ports.
 - c. Cut component connecting tubing with tubing cutter and remove component from unit.
 - d. Carefully unsweat remaining tubing stubs when necessary. Oil can ignite when exposed to torch flame.

Proceed as follows to inspect and prepare the unit for initial start-up:

1. Remove access panels (see Fig. 19).
2. Read and follow instructions on all WARNING, CAUTION, and INFORMATION labels attached to, or shipped with, unit.
3. Make the following inspections:
 - a. Inspect for shipping and handling damages such as broken lines, loose parts, disconnected wires, etc.
 - b. Inspect all field- and factory-wiring connections. Be sure that connections are completed and tight.
 - c. Ensure wires do not touch refrigerant tubing or sharp sheet metal edges.
 - d. Inspect coil fins. If damaged during shipping and handling, carefully straighten fins with a fin comb.

PDD4, PDS4



WARNING

FIRE, EXPLOSION HAZARD

Failure to follow this warning could result in personal injury, death or property damage.

Do not purge gas supply into the combustion chamber. Do not use a match or other open flame to check for gas leaks. Use a commercially available soap solution made specifically for the detection of leaks to check all connections. A fire or explosion may result causing property damage, personal injury or loss of life.

4. Verify the following conditions:

- a. Make sure gas line is free of air. Before lighting the unit for the first time, perform the following with the gas valve in the "OFF" position:

NOTE: If the gas supply pipe was not purged before connecting the unit, it will be full of air. It is recommended that the ground joint union be loosened, and the supply line be allowed to purge until the odor of gas is detected. Never purge gas lines into a combustion chamber. Immediately upon detection of gas odor, retighten the union. Allow 5 minutes to elapse, then light unit.

- b. Make sure that condenser-fan blade is correctly positioned in fan orifice. Leading edge of condenser-fan blade should be 1/2 in. (12 mm) maximum from fan orifice.
- c. Make sure that air filter(s) is in place.
- d. Make sure that condensate drain trap is filled with water to ensure proper drainage.
- e. Make sure that all tools and miscellaneous loose parts have been removed.

START-UP

Step 1 — Check for Refrigerant Leaks



WARNING

EXPLOSION HAZARD

Failure to follow this warning could result in death, serious personal injury, and/or property damage.

Never use air or gases containing oxygen for leak testing or operating refrigerant compressors. Pressurized mixtures of air or gases containing oxygen can lead to an explosion.



Proceed as follows to locate and repair a refrigerant leak and to charge the unit:

1. Locate leak and make sure that refrigerant system pressure has been relieved and reclaimed from both high- and low-pressure ports.
2. Repair leak following Refrigerant Service procedures.

NOTE: Install a bi-flow filter drier whenever the system has been opened for repair.

3. Add a small charge of R-410A refrigerant vapor to system and leak-test unit.
4. Recover refrigerant from refrigerant system and evacuate to 500 microns if no additional leaks are not found.
5. Charge unit with R-410A refrigerant, using an electronic scale. Refer to unit rating plate for required charge.

Step 2 — Unit Sequence of Operation

a. CONTINUOUS FAN

- (1.) Thermostat closes circuit R to G energizing the blower motor for continuous fan.

b. COOLING MODE

- (1.) If indoor temperature is above temperature set point thermostat closes circuits R to G, R to Y and R to O-The unit delivers cooling airflow.

c. HEAT PUMP HEATING MODE

Outdoor temperature above balance point setpoint of thermostat.

- (1.) On a call for heating, terminals "Y" and "G" of the Hybrid thermostat are energized. The "Y" signal is sent to the Defrost Board (DB) terminal "Y". The DB has a built in five minute anti-short cycle timer which will not allow the compressor to restart before the time delay has expired.

- (2.) "T2" energizes the compressor contactor via the High Pressure Switch (HPS) and Low Pressure Switch (LPS). The compressor and outdoor fan start. Thermostat "G" energizes the Interface Fan Board terminal "G". The blower motor is energized through contacts of the IFB.

- (3.) When the thermostat removes the "Y" and "G" calls, the compressor contactor and outdoor fan are de-energized. The evaporator motor is de-energized after a 90 sec. delay.

d. GAS HEATING MODE

Outdoor temperature below balance point setpoint of thermostat.

Heating Sequence of Operation (Single Phase Models)

(See Fig. 15 and unit wiring label)

On a call for heating, terminal W of the thermostat is energized, starting the induced-draft motor for a 5 second pre-purge. When the pressure switch senses that the induced-draft motor is moving sufficient combustion air, the burner sequence begins. This function is controlled by the integrated gas unit controller (IGC). The indoor (evaporator) -fan motor is energized 30 seconds after flame is established. When the thermostat is satisfied and W is de-energized, the burners stop firing and the indoor (evaporator) fan motor shuts off after a 90 second time-off delay. Please note that the IGC has the capability to automatically reduce the indoor fan motor on delay and increase the indoor fan motor off delay in the event of high duct static and/or a partially-clogged filter.

Heating Sequence of Operation (3-Phase Models)

(See Fig. 15 and 16 and unit wiring label.)

On a call for heating, terminal W of the thermostat is energized, starting the induced-draft motor. When the pressure switch senses that the induced-draft motor is moving sufficient combustion air, the burner sequence begins. This function is performed by the integrated gas unit controller (IGC). The indoor (evaporator)-fan motor is energized 45 sec after flame is established. When the thermostat is satisfied and W is de-energized, the burners stop firing and the indoor (evaporator) fan motor shuts off after a 45-sec time-off delay. Please note that the IGC has the capability to automatically reduce the indoor fan motor on delay and increase the indoor fan motor off delay in the event of high duct static and/or partially-clogged filter.

NOTE: An LED (light-emitting diode) indicator is provided on the control board to monitor operation. The control board is located by removing the burner access panel (see Fig. 19). During normal operation, the LED is continuously on.

Step 3 — Start-up Heating and Make Adjustments

⚠ CAUTION

UNIT COMPONENT DAMAGE HAZARD

Failure to follow this caution may result in damage to the unit being installed.

Complete the required procedures given in the Pre-Start-Up section before starting the unit. Do not jumper any safety devices when operating the unit.

Complete the required procedures given in the Pre-Start-Up section before starting the unit. Do not jumper any safety devices when operating the unit. Make sure that burner orifices are properly aligned. Unstable operation may occur when the burner orifices in the manifold are misaligned.

Follow the lighting instructions on the heating section operation label (located on the inside of the control access panel) to start the heating section.

NOTE: Make sure that gas supply has been purged, and that all gas piping has been checked for leaks.

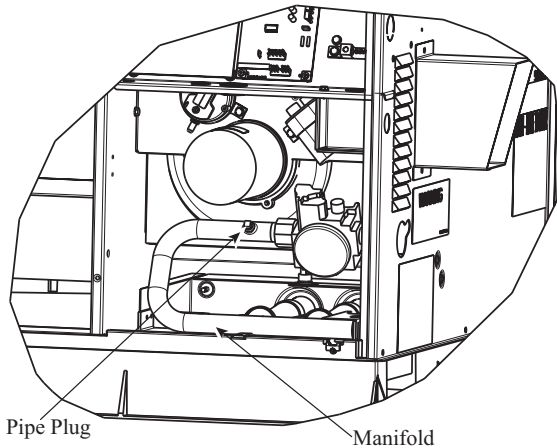

Fig. 10 - Burner Assembly

A07679

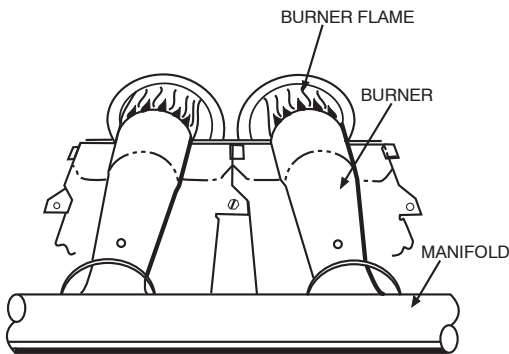

Fig. 11 - Monoport Burner

C99021

Check Heating Control

Start and check the unit for proper heating control operation as follows (see furnace lighting instructions located on the inside of the control access panel):

1. Place room thermostat SYSTEM switch in the HEAT position and the fan switch is placed in AUTO position.
2. Set the heating temperature control of the thermostat above room temperature.

3. The induced-draft motor will start.
4. On a call for heating, the main burner should light within 5 sec. of the spark being energized. If the burners do not light, there is a 22-sec. delay before another 5-sec. try. If the burners still do not light, this sequence is repeated. If the burners do not light within 15 minutes from the initial call for heat, there is a lockout. To reset the control, break the 24-v power to W.
5. The evaporator fan will turn on 45 sec. after the flame has been established. The evaporator fan will turn off 45 sec. after the thermostat has been satisfied. Please note that the integrated gas unit controller (IGC) has the capability to automatically reduce the evaporator "ON" delay and increase the evaporator "OFF" delay in the event of high duct static and/or partially-clogged filter.

Check Gas Input

Check gas input and manifold pressure after unit start-up (See Table 3). If adjustment is required proceed as follows:

- The rated gas inputs shown in Table 3 are for altitudes from sea level to 2000 ft (610 m) above sea level. These inputs are based on natural gas with a heating value of 1025 Btu/ft³ at 0.60 specific gravity, or propane gas with a heating value of 2500 Btu/ft³ at 1.5 specific gravity.

IN THE U.S.A.:

The input rating for altitudes above 2,000 ft (610 m) must be reduced by 4% for each 1,000 ft (305 m) above sea level.

For installations below 2,000 ft (610 m), refer to the unit rating plate.

For installations above 2,000 ft (610 m) multiply the input by on the rating plate by the derate multiplier in Table 4 for correct input rate.

Table 4 – Altitude Derate Multiplier for U.S.A.*

ALTITUDE FT (M)	PERCENT OF DERATE	DERATE MULTIPLIER FACTOR†
0–2000 (0–610)	0	1.00
2001–3000* (610–914)	8–12	0.90
3001–4000 (315–1219)	12–16	0.86
4001–5000 (1220–1524)	16–20	0.82
5001–6000 (1524–1829)	20–24	0.78
6001–7000 (1829–2134)	24–28	0.74
7001–8000 (2134–2438)	28–32	0.70
8001–9000 (2439–2743)	32–36	0.66
9001–10,000 (2744–3048)	36–40	0.62

* In Canada see Canadian Altitude Adjustment.

† Derate multiplier factors are based on midpoint altitude for altitude range.

IN CANADA:

The input rating for altitudes from 2,000 to 4,500 ft (610 m to 1372 m) above sea level must be derated 10% by an authorized Gas Conversion Station or Dealer.

EXAMPLE:

90,000 Btu/hr Input Furnace Installed at 4300 ft (1311 m).

Furnace Input Rate at Sea Level	X	Derate Multiplier Factor	=	Furnace Input Rate at Installation Altitude
90,000	X	0.90	=	81,000

When the gas supply being used has a different heating value or specific gravity, refer to national and local codes, or contact your distributor to determine the required orifice size.

PDD4, PDS4



CAUTION

UNIT DAMAGE HAZARD

Failure to follow this caution may result in reduced unit and/or component life.

Do Not redrill an orifice. Improper drilling (burrs, out-of-round holes, etc.) can cause excessive burner noise and misdirection of burner flame. If orifice hole appears damaged or it is suspected to have been redrilled, check orifice hole with a numbered drill bit of correct size.

Adjust Gas Input

The gas input to the unit is determined by measuring the gas flow at the meter or by measuring the manifold pressure. Measuring the gas flow at the meter is recommended for natural gas units. The manifold pressure must be measured to determine the input of propane gas units.

Measure Gas Flow (Natural Gas Units)

Minor adjustment to the gas flow can be made by changing the manifold pressure. The manifold pressure must be maintained between 3.2 and 3.8 IN. W.C.

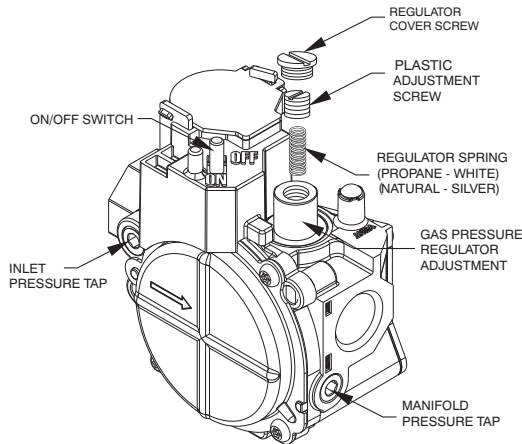

A07751

Fig. 12 - Single-Stage Gas Valve

If larger adjustments are required, change main burner orifices following the recommendations of national and local codes.

NOTE: All other appliances that use the same meter must be turned off when gas flow is measured at the meter.

Proceed as follows:

1. Turn off gas supply to unit.
2. Remove pipe plug on manifold (See Fig. 10) and connect manometer. Turn on gas supply to unit.
3. Record number of seconds for gas meter test dial to make one revolution.
4. Divide number of seconds in Step 3 into 3600 (number of seconds in one hr).
5. Multiply result of Step 4 by the number of cubic feet (cu ft) shown for one revolution of test dial to obtain cubic feet (cu ft) of gas flow per hour.
6. Multiply result of Step 5 by Btu heating value of gas to obtain total measured input in Btuh. Compare this value with heating input shown in Table 3 (Consult the local gas supplier if the heating value of gas is not known).

EXAMPLE: Assume that the size of test dial is 1 cu ft, one revolution takes 32 sec, and the heating value of the gas is 1050 Btu/ft³. Proceed as follows:

1. 32 sec. to complete one revolution.
2. $3600 \div 32 = 112.5$.
3. $112.5 \times 1 = 112.5 \text{ ft}^3 \text{ of gas flow/hr.}$
4. $112.5 \times 1050 = 118,125 \text{ Btuh input.}$

If the desired gas input is 115,000 Btuh, only a minor change in the manifold pressure is required.

Observe manifold pressure and proceed as follows to adjust gas input:

1. Remove regulator cover screw over plastic adjustment screw on gas valve (See Fig. 12).
2. Turn plastic adjustment screw clockwise to increase gas input, or turn plastic adjustment screw counterclockwise to decrease input (See Fig. 12). Manifold pressure must be between 3.2 and 3.8 IN. W.C.



WARNING

FIRE AND UNIT DAMAGE HAZARD

Failure to follow this warning could result in personal injury or death and/or property damage.

Unsafe operation of the unit may result if manifold pressure is outside this range.

3. Replace regulator cover screw on gas valve (See Fig. 12).
4. Turn off gas supply to unit. Remove manometer from pressure tap and replace pipe plug on gas valve. (See Fig. 10.) Turn on gas to unit and check for leaks.

Measure Manifold Pressure (Propane Units)

Refer to propane kit installation instructions for properly checking gas input.

NOTE: For installations below 2,000 ft (610 m), refer to the unit rating plate for proper propane conversion kit. For installations above 2,000 ft (610 m), contact your distributor for proper propane conversion kit.

Check Burner Flame

With control access panel (see Fig. 19) removed, observe the unit heating operation. Watch the burner flames to see if they are light blue and soft in appearance, and that the flames are approximately the same for each burner. Propane will have blue flame (See Fig. 12). Refer to the Maintenance section for information on burner removal.

Normal Operation

An LED (light-emitting diode) indicator is provided on the integrated gas unit controller (IGC) to monitor operation. The IGC is located by removing the control access panel (see Fig. 19). During normal operation, the LED is continuously on (See Table 5 for error codes).

Airflow and Temperature Rise

The heating section for each size unit is designed and approved for heating operation within the temperature-rise range stamped on the unit rating plate.

Table 7, 8 and 9 show the approved temperature rise range for each heating input, and the air delivery cfm at various temperature rises for a given external static pressure. The heating operation airflow must produce a temperature rise that falls within the approved range. For single phase units only, "High" blower speed is for high static cooling only and must not be used for gas heating.

Refer to Indoor Airflow and Airflow Adjustments section to adjust heating airflow when required.

Limit Switches

Normally closed limit switch (LS) completes the control circuit. Should the leaving-air temperature rise above the maximum allowable temperature, the limit switch opens and the control circuit "breaks." Any interruption in the control circuit instantly closes the gas valve and stops gas flow to the burners. The blower motor continues to run until LS resets.

When the air temperature at the limit switch drops to the low-temperature setting of the limit switch, the switch closes and completes the control circuit. The direct-spark ignition system cycles and the unit returns to normal heating operation.

Table 5 – LED Indications

STATUS CODE	LED INDICATION
Normal Operation ²	On
No Power Hardware Failure	Off
Check fuse, low voltage circuit	1 Flash
Limit Switch Fault	2 Flashes
Flame Sense Fault	3 Flashes
Four Consecutive Limit Switch Faults	4 Flashes
Ignition Lockout Fault	5 Flashes
Pressure Switch Fault	6 Flashes
Rollout Switch Fault	7 Flashes
Internal Control Fault	8 Flashes
Temporary 1 hr auto reset ¹	9 Flashes

NOTES:

1. This code indicates an internal processor fault that will reset itself in one hr. Fault can be caused by stray RF signals in the structure or nearby. This is a UL requirement.
2. LED indicates acceptable operation. Do not change ignition control board.
3. When W is energized the burners will remain on for a minimum of 60 sec.
4. If more than one error mode exists they will be displayed on the LED in sequence.

Rollout Switch

The function of the rollout switch is to close the main gas valve in the event of flame rollout. The switch is located above the main burners. When the temperature at the rollout switch reaches the maximum allowable temperature, the control circuit trips, closing the gas valve and stopping gas flow to the burners. The indoor (evaporator) fan motor (IFM) and induced draft motor continue to run until switch is reset. The IGC LED will display FAULT CODE 7.

Step 4 — Start-up Cooling and Make Adjustments

Complete the required procedures given in the Pre-Start-Up section before starting the unit. Do not jumper any safety devices when operating the unit. Do not operate the compressor when the outdoor temperature is below 40°F (4.4°C) (unless accessory low-ambient kit is installed). Do not rapid-cycle the compressor. Allow 5 minutes between on cycles to prevent compressor damage.

Checking Cooling Control Operation

Start and check the unit for proper cooling control operation as follows:

1. Place room thermostat SYSTEM switch in OFF position. Observe that blower motor starts when FAN switch is placed in ON position and shuts down when FAN switch is placed in AUTO position.
2. Place SYSTEM switch in COOL position and FAN switch in AUTO position. Set cooling control below room temperature. Observe that compressor, condenser fan, and evaporator blower motors start. Observe that cooling cycle shuts down when control setting is satisfied. The evaporator fan will continue to run for 90 sec.

IMPORTANT: Three-phase, scroll compressors units are direction oriented. Unit must be checked to ensure proper compressor 3-phase power lead orientation. If not corrected within 5 minutes, the internal protector will shut off the compressor. The 3-phase power leads to the unit must be reversed to correct rotation. When turning backwards, the difference between compressor suction and discharge pressures will be near zero.

Checking and Adjusting Refrigerant Charge

The refrigerant system is fully charged with R-410A refrigerant and is tested and factory sealed. Allow system to operate a minimum of 15 minutes before checking or adjusting charge.

WARNING

EXPLOSION HAZARD

Failure to follow this warning could result in death, serious personal injury, and/or property damage.

Never use air or gases containing oxygen for leak testing or operating refrigerant compressors. Pressurized mixtures of air or gases containing oxygen can lead to an explosion.

NOTE: Adjustment of the refrigerant charge is not required unless the unit is suspected of not having the proper R-410A charge.

NOTE: Some units have fixed orifice refrigerant metering devices. There is a different charging procedure for both expansion devices. Refer to the correct procedure for your unit.

The charging label and the tables shown refer to system temperatures and pressures in cooling mode only. A refrigerant charging label is attached to the inside of the compressor access panel. (See Fig. 17 Subcool chart for units with TXV and superheat chart for units with fixed orifice.) The chart includes the required liquid line temperature at given discharge line pressures and outdoor ambient temperatures.

A superheat chart is attached to the inside of the compressor access panel for the unit with fixed metering device. Refer to the charging procedure on the label.

An accurate thermocouple- or thermistor-type thermometer, and a gauge manifold are required when using the subcooling charging method for evaluating the unit charge. Do not use mercury or small dial-type thermometers because they are not adequate for this type of measurement.

CAUTION

UNIT DAMAGE HAZARD

Failure to follow this caution may result in unit damage.

When evaluating the refrigerant charge, an indicated adjustment to the specified factory charge must always be very minimal. If a substantial adjustment is indicated, an abnormal condition exists somewhere in the cooling system, such as insufficient airflow across either coil or both coils.

Proceed as follows:

1. Remove caps from low- and high-pressure service fittings.
2. Using hoses with valve core depressors, attach low- and high-pressure gauge hoses to low- and high-pressure service fittings, respectively.
3. Start unit in Cooling Mode and let unit run until system pressures stabilize.
4. Measure and record the following:
 - a. Outdoor ambient-air temperature (°F (°C) db).
 - b. Liquid line temperature (°F (°C)).
 - c. Discharge (high-side) pressure (psig).
 - d. Suction (low-side) pressure (psig) (for reference only).
5. Using “Cooling Charging Charts,” compare outdoor-air temperature(°F (°C) db) with the discharge line pressure

PDD4, PDS4

(psig) to determine desired system operating liquid line temperature (See Fig. 17).

6. Compare actual liquid line temperature with desired liquid line temperature. Using a tolerance of $\pm 2^{\circ}\text{F}$ ($\pm 1.1^{\circ}\text{C}$), add refrigerant if actual temperature is more than 2°F (1.1°C) higher than proper liquid line temperature, or remove refrigerant if actual temperature is more than 2°F (1.1°C) lower than required liquid line temperature.

NOTE: If the problem causing the inaccurate readings is a refrigerant leak, refer to the Check for Refrigerant Leaks section.

Indoor Airflow and Airflow Adjustments

⚠ CAUTION

UNIT OPERATION HAZARD

Failure to follow this caution may result in unit damage.

For cooling operation, the recommended airflow is 350 to 450 cfm for each 12,000 Btuh of rated cooling capacity. For heating operation, the airflow must produce a temperature rise that falls within the range stamped on the unit rating plate.

NOTE: Be sure that all supply-and return-air grilles are open, free from obstructions, and adjusted properly.

⚠ WARNING

ELECTRICAL SHOCK HAZARD

Failure to follow this warning could result in personal injury or death.

Before making any indoor wiring adjustments, shut off gas supply. Then disconnect electrical power to the unit and install lockout tag before changing blower speed.

This unit has independent fan speeds for gas heating and cooling modes. Single phase units also have a dedicated continuous fan speed. All models (1 phase and 3 phase), have a field-selectable capability to run two different cooling speeds: A normal cooling fan speed (350-450 CFM/Ton) and an enhanced dehumidification fan speed (As low as 320 CFM/Ton) for use with either a dehumidistat or a thermostat that supports dehumidification.

This unit is factory-set for use with a single cooling fan speed. For single phase models, the cooling speed is marked "COOL" on the IGC (See Fig. 13). For 3-phase models, the cooling speed is marked "LOW" on the interface board (IFB) (See Fig. 14). The factory-shipped settings are noted in Tables 7 and 8. There are up to 3 additional speed tap wires available for use in either gas heating mode, cooling mode, or continuous fan mode (For color coding on the indoor fan motor leads, see Table 6). For single phase models, one of the additional speed tap wires is connected to the continuous fan, with the other 2 wires shipped loose in the control box near the IGC. For three phase models, the additional 3 speed tap wires are shipped loose with vinyl caps and are located in the control box near the interface fan board (IFB) (See Fig. 14).

Gas Heating Fan Speed Set-up (Single Phase Models):

To change the gas heating speed:

1. Remove existing speed tap wire from the "HEAT" terminal on the IGC.
2. Connect the desired speed tap wire on the "HEAT" terminal on the IGC board. "High" speed is for high static cooling only and must not be used for gas heating speed. Make sure that the speed chosen delivers temperature rise within the rise range listed on the unit.

Gas Heating Fan Speed Set-up (3-Phase Models)

To change the gas heating speed:

1. Remove the vinyl cap off of the desired speed tap wire (Refer to Table 6 for color coding). Table 8 and 9 show the temperature rise associated with each fan speed for a given static pressure. Make sure that the speed chosen delivers a temperature rise within the rise range listed on the unit rating plate.
2. Remove the current speed tap wire from the "GAS HEAT" terminal on the interface fan board (IFB) (Fig. 14) and place vinyl cap over the connector on the wire.
3. Connect the desired speed tap wire to the "GAS HEAT" terminal on the interface fan board (IFB).

Cooling Fan Speed Set-up (Dehumidification feature not used) (Single Phase Models):

To change cooling speed:

1. Remove existing speed tap wire from the "COOL" terminal on the IGC board. Add the wet coil pressure drop in Table 10 to the system static to determine the correct cooling airflow speed in Table 7 that will deliver the nominal cooling airflow listed in Table 1 for each size.
2. Connect the desired speed tap wire on the "COOL" terminal on the IGC board.

Single Cooling Fan Speed Set-up (Dehumidification feature not used) (3-Phase Models)

To change cooling speed:

1. Remove the vinyl cap off of the desired speed tap wire (Refer to Table 6 for color coding). Add the wet coil pressure drop in Table 10 to the system static to determine the correct cooling airflow speed in Table 8 or 9 that will deliver the nominal cooling airflow as listed in Table 1 for each size.
2. Remove the current speed tap wire from the "LOW" terminal on the interface fan board (IFB) (Fig. 14) and place vinyl cap over the connector on the wire.
3. Connect the desired speed tap wire to the "LOW" terminal on the interface fan board (IFB).

Dehumidification Cooling Fan Speed Set-up (Single Phase Models):

IMPORTANT: Dehumidification control must open control circuit on humidity rise above set point.

Use of the dehumidification cooling fan speed requires use of either a 24 VAC dehumidistat or a thermostat which includes control of a 24 VAC dehumidistat connection. In either case, the dehumidification control must open the control circuit on humidity rise above the dehumidification set point.

1. Move shunt jumper on IGC board to "DH" (See Fig. 13).
2. Refer to airflow table (Table 7) to determine allowable speeds for the dehumidification cooling fan speed. Speeds that are not allowed are shaded in Table 7.
3. Connect selected speed tap wire to "DHUM" terminal on the IGC board. Verify that static pressure is in the acceptable range for the speed tap to be used for dehumidification cooling.

Two Cooling Fan Speeds Set-up (Dehumidification feature used) (3-Phase Models)

IMPORTANT: Dehumidification control must open control circuit on humidity rise above set point.

Use of the dehumidification cooling fan speed requires use of either a 24 VAC dehumidistat or a thermostat which includes control of a 24 VAC dehumidistat connection. In either case, the dehumidification control must open the control circuit on humidity rise above the dehumidification set point.

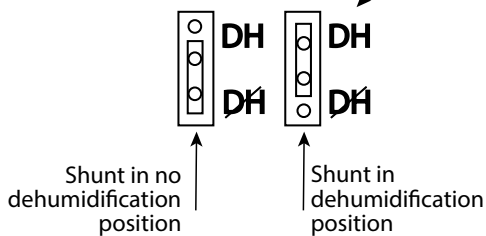
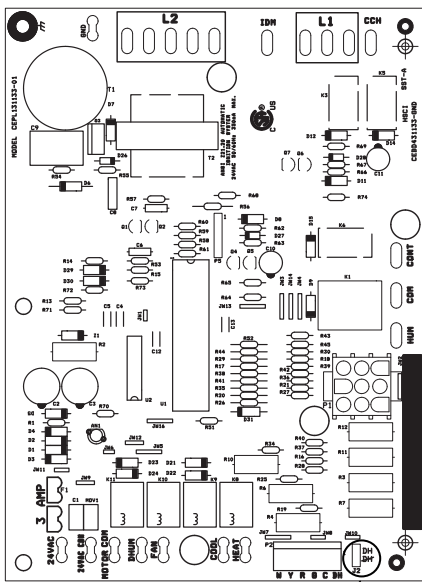

A14399

Fig. 13 - Single Phase IGC Board

1. Remove fan speed tap wire from the “LOW” terminal on the interface fan board (IFB) (Fig. 14).
2. Determine correct normal cooling fan speed for unit and application. Add the wet coil pressure drop in Table 10 to the system static to determine the correct cooling airflow speed in Table 8 or 9 that will deliver the nominal cooling airflow as listed in Table 1 for each size.
3. Remove the vinyl cap off of the desired speed tap wire (Refer to Table 6 for color coding) for the normal cooling fan speed and place desired speed tap wire on “HIGH” on the interface board.
4. Refer to airflow tables (Table 8 or 9) to determine allowable speeds for the dehumidification cooling fan speed. In Table 8 or 9, speeds that are not allowed for dehumidification cooling are shaded.
5. Remove the vinyl cap off of the desired speed tap wire (Refer to Table 6 for color coding) for the dehumidification cooling fan speed and place desired speed tap wire on the “LOW” connection on the interface board (IFB). Verify that static pressure is in the acceptable range for the speed tap to be used for dehumidification cooling.
6. Use any spare vinyl plugs to cap any unused speed tap wires.

NOTE: For heat pump operation, the recommended airflow is 350 to 450 CFM for each 12,000 Btuh of rated cooling capacity.

Continuous Fan Speed Set-up (Single Phase Models):

To change continuous fan speed:

1. Remove existing speed tap wire from the “FAN” terminal on the IGC.
2. Connect the desired speed tap wire on the “FAN” terminal on the IGC board.

Continuous Fan Operation (3-Phase Models)

When the DEHUM feature is not used, the continuous fan speed will be the same as cooling fan speed. When the DEHUM feature

is used, the continuous fan will operate on IFB “LOW” speed when the DH control lead is not energized, or IFB “HIGH” speed when the DH lead is energized (see Fig. 14).

Table 6 – Color Coding for Indoor Fan Motor Leads

Black = High Speed
Orange = Med-High Speed
Red = Med Speed
Pink = Med-Low Speed
Blue = Low Speed

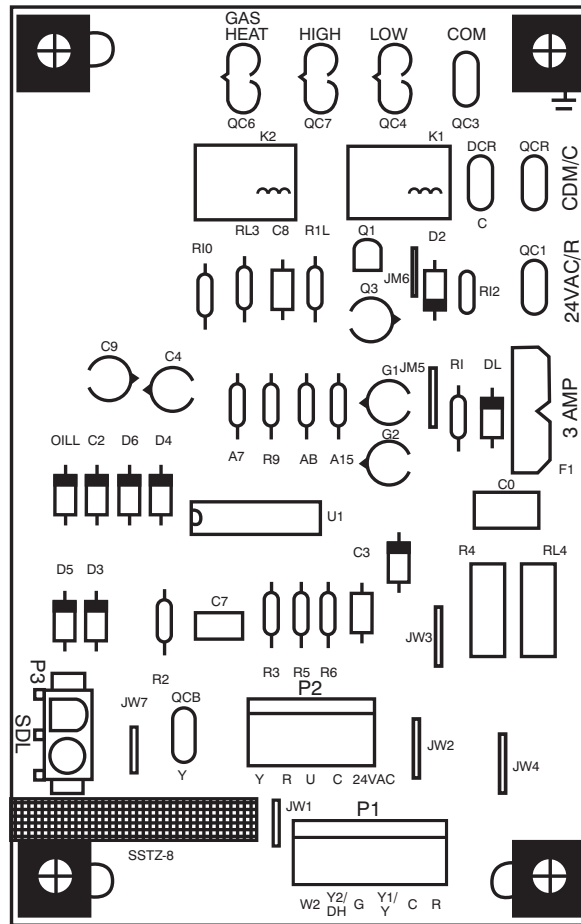

A09058

Fig. 14 - Interface Fan Board (IFB)

Step 5 — Defrost Control

Defrost Control

The defrost control is used in all R-410A heat pump models. Its features include selectable defrost intervals of 30, 60, 90 minutes, and standard defrost speed up capability. This section describes the sequence of operation and trouble shooting methods for this control.

Defrost Sequence

The defrost control is a time/temperature control that has field selectable settings of 30, 60, and 90 minutes. These represent the amount of time that must pass after closure of the defrost thermostat before the defrost sequence begins.

The defrost thermostat senses coil temperature throughout the heating cycle. When the coil temperature reaches the defrost thermostat setting, it will close, which energizes the DFT terminal and begins the defrost timing sequence. When the DTF has been energized for the selected time, the defrost cycle begins, and the control shifts the reversing valve into cooling position, and turns the outdoor fan off. This shifts hot gas flow into the outdoor coil which melts the frost from the coil. The defrost cycle is terminated when defrost thermostat opens, or automatically after 10 minutes.

PDD4, PDS4

Table 7 – Dry Coil Air Delivery* - Horizontal and Downflow Discharge - Sizes 24-60 230VAC 1-Phase

Unit Size	Heating Rise of (°C)	Motor Speed	Tap	Allowable Functions	ESP (in. W.C.)												
					0.1	0.2	0.3	0.4	0.5	0.6	0.7	0.8	0.9	1			
24040	25 – 55 (14 – 31)	Low ³	Blue	Alternate Gas Heating	CFM	654	552	454	338	x	x	x	x	x	x	x	
					BHP	0.09	0.10	0.10	0.11	x	x	x	x	x	x	x	
		Med – Low ¹	Pink	Gas Heating Alternate Cooling	Gas Heat Rise (°F)	45	54	NA	NA	NA	NA	NA	NA	NA	NA	NA	NA
					Gas Heat Rise (°C)	25	30	NA	NA	NA	NA	NA	NA	NA	NA	NA	NA
		Medium ²	Red	Cooling Alternate Gas Heating	CFM	840	759	677	600	505	411	293	x	x	x	x	x
					BHP	0.14	0.15	0.16	0.16	0.17	0.17	0.18	0.18	0.18	0.18	0.18	0.18
	High	Black	High Static Cooling Only	CFM	888	818	750	679	606	511	425	320	238	166	104	66	
				BHP	0.18	0.18	0.19	0.19	0.20	0.20	0.21	0.21	0.21	0.22	0.22		
	24060	25 – 55 (14 – 31)	Med – High	Orange	Alternate Cooling Alternate Gas Heating	Gas Heat Rise (°F)	34	36	40	44	49	NA	NA	NA	NA	NA	NA
						Gas Heat Rise (°C)	19	20	22	24	27	NA	NA	NA	NA	NA	NA
			High	Black	High Static Cooling Only	CFM	1133	1069	995	930	854	784	701	628	549	464	
						BHP	0.26	0.27	0.28	0.29	0.30	0.30	0.31	0.31	0.31	0.32	0.33
Low ³			Blue	Alternate Cooling	Gas Heat Rise (°F)	26	28	30	32	35	38	42	47	54	NA		
					Gas Heat Rise (°C)	15	15	17	18	19	21	24	26	30	NA		
Med – Low		Pink	Alternate Cooling Alternate Gas Heating	CFM	1291	1241	1190	1131	1081	1028	949	854	742	616			
				BHP	0.41	0.42	0.43	0.43	0.44	0.45	0.44	0.44	0.42	0.40	0.38		
Medium ²		Red	Cooling Alternate Gas Heating	CFM	654	552	454	338	x	x	x	x	x	x			
				BHP	0.09	0.10	0.10	0.11	x	x	x	x	x	x	x		
High		Black	High Static Cooling Only	Gas Heat Rise (°F)	NA	NA	NA	NA	NA	NA	NA	NA	NA	NA			
				Gas Heat Rise (°C)	NA	NA	NA	NA	NA	NA	NA	NA	NA	NA	NA		
24060	25 – 55 (14 – 31)	Med – Low	Pink	Alternate Cooling Alternate Gas Heating	CFM	840	759	677	600	505	411	293	x	x	x		
					BHP	0.14	0.15	0.16	0.16	0.17	0.17	0.18	0.18	0.18	0.18	0.18	
		Medium ²	Red	Cooling Alternate Gas Heating	Gas Heat Rise (°F)	53	NA	NA	NA	NA	NA	NA	NA	NA	NA		
					Gas Heat Rise (°C)	30	NA	NA	NA	NA	NA	NA	NA	NA	NA	NA	
		High	Black	High Static Cooling Only	CFM	888	818	750	679	606	511	425	320	238	166		
					BHP	0.18	0.18	0.19	0.19	0.20	0.20	0.21	0.21	0.21	0.22	0.22	
	Med – High ¹	Orange	Gas Heating Alternate Cooling	CFM	1133	1069	995	930	854	784	701	628	549	464			
				BHP	0.26	0.27	0.28	0.29	0.30	0.30	0.31	0.31	0.31	0.32	0.33		
	High	Black	High Static Cooling Only	Gas Heat Rise (°F)	40	42	45	48	53	NA	NA	NA	NA	NA			
				Gas Heat Rise (°C)	22	23	25	27	29	NA	NA	NA	NA	NA	NA		
	High	Black	High Static Cooling Only	CFM	1291	1241	1190	1131	1081	1028	949	854	742	616			
				BHP	0.41	0.42	0.43	0.43	0.44	0.45	0.44	0.42	0.40	0.38			

*Air delivery values are without air filter and are for dry coil (See Wet Coil Pressure Drop table).

"High Static Cooling" = Only to be used for cooling function (Not allowed for gas heating function)

¹ Factory-shipped gas heating speed

² Factory-shipped cooling speed

³ Factory-shipped continuous fan speed

"NA" = Not allowed for gas heating speed

NOTE: Duct field-supplied air filter pressure drop and wet coil pressure drop to obtain static pressure available for ducting. Shaded areas indicate speed/static combinations that are not permitted for dehumidification speed.

Table 7 - Dry Coil Air Delivery* - Horizontal and Downflow Discharge - Sizes 24-60 230VAC 1-Phase (Cont)

Unit Size	Heating Rise of (°C)	Motor Speed	Tap	Allowable Functions	ESP (in. W.C.)												
					0.1	0.2	0.3	0.4	0.5	0.6	0.7	0.8	0.9	1			
30040	25 - 55 (14 - 31)	Low ³	Blue	Alternate Gas Heating	CFM	654	552	454	338	x	x	x	x	x	x	x	
					BHP	0.09	0.10	0.10	0.11	x	x	x	x	x	x	x	
		Med-Low ¹	Pink	Gas Heating Alternate Cooling	Gas Heat Rise (°F)	45	54	NA	NA	NA	NA	NA	NA	NA	NA	NA	NA
					Gas Heat Rise (°C)	25	30	NA	NA	NA	NA	NA	NA	NA	NA	NA	NA
		Medium ²	Red	Cooling Alternate Gas Heating	CFM	840	759	677	600	505	411	293	x	x	x	x	x
					BHP	0.14	0.15	0.16	0.16	0.17	0.17	0.18	0.18	0.18	0.18	0.18	0.18
	High	Black	High Static Cooling Only	CFM	1104	1038	979	915	844	782	712	639	532	452	361		
				BHP	0.26	0.27	0.28	0.28	0.29	0.30	0.30	0.30	0.31	0.31	0.32		
	30060	25 - 55 (14 - 31)	Low ³	Blue	Alternate Cooling Alternate Gas Heating	CFM	654	552	454	338	x	x	x	x	x	x	x
						BHP	0.09	0.10	0.10	0.11	x	x	x	x	x	x	x
			Med-Low	Pink	Gas Heating Alternate Cooling	Gas Heat Rise (°F)	NA	NA	NA	NA	NA	NA	NA	NA	NA	NA	NA
						Gas Heat Rise (°C)	NA	NA	NA	NA	NA	NA	NA	NA	NA	NA	NA
Medium ²			Red	Cooling Alternate Gas Heating	CFM	840	759	677	600	505	411	293	x	x	x		
					BHP	0.14	0.15	0.16	0.16	0.17	0.17	0.18	0.18	0.18	0.18	0.18	
High		Black	High Static Cooling Only	CFM	1291	1241	1190	1131	1081	1028	949	854	742	616			
				BHP	0.41	0.42	0.43	0.43	0.44	0.45	0.45	0.44	0.42	0.40	0.38		
30060		25 - 55 (14 - 31)	Low ³	Blue	Alternate Cooling Alternate Gas Heating	CFM	654	552	454	338	x	x	x	x	x	x	
						BHP	0.09	0.10	0.10	0.11	x	x	x	x	x	x	
			Med-Low	Pink	Gas Heating Alternate Cooling	Gas Heat Rise (°F)	NA	NA	NA	NA	NA	NA	NA	NA	NA	NA	
						Gas Heat Rise (°C)	NA	NA	NA	NA	NA	NA	NA	NA	NA	NA	NA
	High		Black	High Static Cooling Only	CFM	840	759	677	600	505	411	293	x	x	x		
					BHP	0.14	0.15	0.16	0.16	0.17	0.17	0.18	0.18	0.18	0.18	0.18	

*Air delivery values are without air filter and are for dry coil (See Wet Coil Pressure Drop table).

"High Static Cooling" = Only to be used for cooling function (Not allowed for gas heating function)

¹ Factory-shipped gas heating speed

² Factory-shipped cooling speed

³ Factory-shipped continuous fan speed

"NA" = Not allowed for gas heating speed

NOTE: Duct field-supplied air filter pressure drop and wet coil pressure drop to obtain static pressure available for ducting.

Shaded areas indicate speed/static combinations that are not permitted for dehumidification speed.

Table 7 - Dry Coil Air Delivery* - Horizontal and Downflow Discharge - Sizes 24-60 230VAC 1-Phase (Cont)

Unit Size	Heating Rise of (°C)	Motor Speed	Tap	Allowable Functions	ESP (in. W.C.)											
					0.1	0.2	0.3	0.4	0.5	0.6	0.7	0.8	0.9	1		
36060	25 - 55 (14 - 31)	Low ³	Blue	Alternate Cooling Alternate Gas Heating	CFM	1117	1042	969	893	869	802	741	677	590	582	
					BHP	0.17	0.18	0.19	0.19	0.21	0.21	0.22	0.23	0.24	0.25	
		Med-Low ¹	Pink	Gas Heating Alternate Cooling	Gas Heat Rise (°F)	40	43	46	50	52	NA	NA	NA	NA	NA	NA
					Gas Heat Rise (°C)	22	24	26	28	29	NA	NA	NA	NA	NA	NA
		Medium ²	Red	Cooling Alternate Gas Heating	CFM	1170	1094	1027	955	883	870	810	748	680	591	
					BHP	0.19	0.20	0.21	0.22	0.23	0.24	0.24	0.25	0.26	0.26	
		Med-High	Orange	Alternate Cooling Alternate Gas Heating	Gas Heat Rise (°F)	38	41	44	47	51	52	NA	NA	NA	NA	
					Gas Heat Rise (°C)	21	23	24	26	28	29	31	NA	NA	NA	
		High	Black	High Static Cooling Only	CFM	1292	1246	1183	1124	1059	995	924	877	856	819	
					BHP	0.25	0.26	0.28	0.29	0.30	0.31	0.32	0.33	0.33	0.34	
36090	35 - 65 (19 - 36)	Low ³	Blue	Alternate Cooling Alternate Gas Heating	CFM	1311	1225	1199	1145	1081	1015	952	902	885	843	
					BHP	0.26	0.27	0.28	0.30	0.31	0.32	0.33	0.33	0.35		
		Med-Low	Pink	Alternate Cooling Alternate Gas Heating	Gas Heat Rise (°F)	35	36	38	40	42	45	49	51	52	55	
					Gas Heat Rise (°C)	19	20	21	22	24	25	27	28	29	30	
		Medium ²	Red	Cooling Alternate Gas Heating	CFM	1311	1225	1199	1145	1081	1015	952	902	885	843	
					BHP	0.26	0.27	0.28	0.30	0.31	0.32	0.33	0.33	0.35		
		High	Black	High Static Cooling Only	Gas Heat Rise (°F)	34	37	37	39	41	44	47	50	51	53	
					Gas Heat Rise (°C)	19	20	21	22	23	25	26	28	28	30	
		High	Black	High Static Cooling Only	CFM	1602	1535	1469	1404	1333	1260	1246	1192	1191	1131	
					BHP	0.26	0.27	0.28	0.30	0.31	0.32	0.33	0.33	0.35		
High	Black	High Static Cooling Only	CFM	1117	1042	969	893	869	802	741	677	590	582			
			BHP	0.17	0.18	0.19	0.19	0.21	0.21	0.22	0.23	0.24				
Med-Low	Pink	Alternate Cooling Alternate Gas Heating	Gas Heat Rise (°F)	61	65	NA	NA	NA	NA	NA	NA	NA	NA			
			Gas Heat Rise (°C)	34	36	NA	NA	NA	NA	NA	NA	NA	NA			
High	Black	High Static Cooling Only	CFM	1170	1094	1027	955	883	870	810	748	680	591			
			BHP	0.19	0.20	0.21	0.22	0.23	0.24	0.24	0.25	0.26				
High	Black	High Static Cooling Only	CFM	1292	1246	1183	1124	1059	995	924	877	856	819			
			BHP	0.25	0.26	0.28	0.29	0.30	0.31	0.32	0.33	0.34				
High	Black	High Static Cooling Only	Gas Heat Rise (°F)	52	54	57	60	64	NA	NA	NA	NA	NA			
			Gas Heat Rise (°C)	29	30	32	33	35	NA	NA	NA	NA				
High	Black	High Static Cooling Only	CFM	1311	1225	1199	1145	1081	1015	952	902	885	843			
			BHP	0.26	0.27	0.28	0.30	0.31	0.32	0.33	0.33	0.35				
High	Black	High Static Cooling Only	Gas Heat Rise (°F)	52	55	56	59	63	NA	NA	NA	NA	NA			
			Gas Heat Rise (°C)	29	31	31	33	35	NA	NA	NA	NA				
High	Black	High Static Cooling Only	CFM	1602	1535	1469	1404	1333	1260	1246	1192	1191	1131			
			BHP	0.26	0.27	0.28	0.30	0.31	0.32	0.33	0.33	0.35				

*Air delivery values are without air filter and are for dry coil (See Wet Coil Pressure Drop table).
 "High Static Cooling" = Only to be used for cooling function (Not allowed for gas heating function)
 1 Factory-shipped gas heating speed
 2 Factory-shipped cooling speed
 3 Factory-shipped continuous fan speed
 "NA" = Not allowed for gas heating speed

NOTE: Ductwork field-supplied air filter pressure drop and wet coil pressure drop to obtain static pressure available for ducting.
 Shaded areas indicate speed/static combinations that are not permitted for dehumidification speed.

Table 7 - Dry Coil Air Delivery* - Horizontal and Downflow Discharge - Sizes 24-60 230VAC 1-Phase (Cont)

Unit Size	Heating Rise of (°C)	Motor Speed	Tap	Allowable Functions	ESP (in. W.C.)											
					0.1	0.2	0.3	0.4	0.5	0.6	0.7	0.8	0.9	1		
42060	25 - 55 (14 - 31)	Low ³	Blue	Alternate Gas Heating	CFM	1001	902	833	777	717	650	575	527	466	419	
					BHP	0.13	0.13	0.14	0.14	0.15	0.16	0.17	0.18	0.19	0.20	
		Med-Low ¹	Pink	Gas Heating	Gas Heat Rise (°F)	45	50	54	NA	NA	NA	NA	NA	NA	NA	NA
					Gas Heat Rise (°C)	25	28	30	NA	NA	NA	NA	NA	NA	NA	NA
		35 - 65 (19 - 36)	Med-High	Orange	Alternate Gas Heating	CFM	1016	950	902	842	783	721	655	590	541	480
						BHP	0.13	0.14	0.15	0.16	0.17	0.18	0.19	0.20	0.21	0.22
	High		Black	High Static Cooling Only	Gas Heat Rise (°F)	32	33	34	35	37	38	40	42	44	47	
					Gas Heat Rise (°C)	18	18	19	20	20	21	22	23	25	26	
	Med-Low		Pink	Cooling Alternate Gas Heating	CFM	1461	1411	1367	1327	1275	1220	1174	1127	1074	1022	
					BHP	0.32	0.33	0.35	0.36	0.37	0.38	0.39	0.40	0.41	0.42	
	High	Black	High Static Cooling Only	Gas Heat Rise (°F)	31	32	33	34	35	37	38	40	42	44		
				Gas Heat Rise (°C)	17	18	18	19	20	20	21	22	23	24		
42090	35 - 65 (19 - 36)	Low ³	Blue	Alternate Gas Heating	CFM	1575	1528	1488	1447	1406	1360	1314	1264	1213	1159	
					BHP	0.40	0.42	0.43	0.44	0.45	0.46	0.47	0.48	0.49	0.50	
		Med-Low	Pink	Cooling Alternate Gas Heating	CFM	1001	902	833	777	717	650	575	527	466	419	
					BHP	0.13	0.13	0.14	0.14	0.15	0.16	0.17	0.18	0.19	0.20	
		High	Black	High Static Cooling Only	Gas Heat Rise (°F)	NA	NA	NA	NA	NA	NA	NA	NA	NA	NA	
					Gas Heat Rise (°C)	NA	NA	NA	NA	NA	NA	NA	NA	NA	NA	
	35 - 65 (19 - 36)	Med-High ¹	Orange	Gas Heating Alternate Cooling	CFM	1403	1358	1316	1265	1217	1167	1116	1067	1012	956	
					BHP	0.29	0.30	0.31	0.33	0.34	0.35	0.36	0.37	0.38	0.39	
		High	Black	High Static Cooling Only	Gas Heat Rise (°F)	48	50	51	53	56	58	61	63	66	69	
					Gas Heat Rise (°C)	27	28	29	30	31	32	34	35	36	37	
		High	Black	High Static Cooling Only	CFM	1461	1411	1367	1327	1275	1220	1174	1127	1074	1022	
					BHP	0.32	0.33	0.35	0.36	0.37	0.38	0.39	0.40	0.41	0.42	
High	Black	High Static Cooling Only	Gas Heat Rise (°F)	46	48	49	51	53	55	58	60	63	66			
			Gas Heat Rise (°C)	26	27	27	28	29	31	32	33	35	36			
High	Black	High Static Cooling Only	CFM	1575	1528	1488	1447	1406	1360	1314	1264	1213	1159			
			BHP	0.40	0.42	0.43	0.44	0.45	0.46	0.47	0.48	0.49	0.50			

*Air delivery values are without air filter and are for dry coil (See Wet Coil Pressure Drop table).
 "High Static Cooling" = Only to be used for cooling function (Not allowed for gas heating function)
 1 Factory-shipped gas heating speed
 2 Factory-shipped cooling speed
 3 Factory-shipped continuous fan speed
 "NA" = Not allowed for gas heating speed
 NOTE: Duct field-supplied air filter pressure drop and wet coil pressure drop to obtain static pressure available for ducting.
 Shaded areas indicate speed/static combinations that are not permitted for dehumidification speed.

Table 7 - Dry Coil Air Delivery* - Horizontal and Downflow Discharge - Sizes 24-60 230VAC 1-Phase (Cont)

Unit Size	Heating Rise of (°C)	Motor Speed	Tap	Allowable Functions	ESP (in. W.C.)												
					0.1	0.2	0.3	0.4	0.5	0.6	0.7	0.8	0.9	1			
48090	35 - 65 (19 - 36)	Low ³	Blue	Gas Heating Alternate Cooling	CFM	644	552	461	376	301	235	x	x	x	x		
					BHP	0.06	0.07	0.07	0.08	0.08	0.09	x	x	x	x		
					Gas Heat Rise (°F)	NA	NA	NA	NA	NA	NA	NA	NA	NA	NA	NA	NA
					Gas Heat Rise (°C)	NA	NA	NA	NA	NA	NA	NA	NA	NA	NA	NA	NA
					CFM	1430	1386	1347	1302	1258	1208	1160	1114	1065	1014		
					BHP	0.26	0.27	0.28	0.29	0.30	0.30	0.32	0.33	0.34	0.35		
	Med-Low ¹	Gas Heating Alternate Cooling	Gas Heat Rise (°F)	47	49	50	52	54	56	58	61	64	NA	NA			
			Gas Heat Rise (°C)	26	27	28	29	30	31	32	34	35	NA	NA			
			CFM	1658	1622	1585	1549	1512	1476	1442	1402	1360	1322				
			BHP	0.39	0.40	0.41	0.42	0.44	0.45	0.46	0.47	0.48	0.49				
			Gas Heat Rise (°F)	41	42	43	44	45	46	47	48	50	51				
			Gas Heat Rise (°C)	23	23	24	24	25	25	26	27	28	28				
48115	30 - 60 (17 - 33)	Med-High	Orange	Alternate Cooling	CFM	1945	1913	1867	1829	1792	1758	1717	1688	1645	1603		
					BHP	0.58	0.59	0.61	0.63	0.64	0.65	0.67	0.68	0.69	0.71		
					Gas Heat Rise (°F)	NA	NA	NA	NA	NA	NA	NA	NA	NA	NA	NA	
					Gas Heat Rise (°C)	NA	NA	NA	NA	NA	NA	NA	NA	NA	NA	NA	
					CFM	2201	2172	2138	2108	2074	2041	1970	1867	1764	1634		
					BHP	0.83	0.84	0.87	0.88	0.89	0.91	0.89	0.83	0.79	0.74		
	High	High Static Cooling Only	CFM	644	552	461	376	301	235	x	x	x	x				
			BHP	0.06	0.07	0.07	0.08	0.08	0.09	x	x	x	x				
			Gas Heat Rise (°F)	NA	NA	NA	NA	NA	NA	NA	NA	NA	NA	NA			
			Gas Heat Rise (°C)	NA	NA	NA	NA	NA	NA	NA	NA	NA	NA	NA			
			CFM	1430	1386	1347	1302	1258	1208	1160	1114	1065	1014				
			BHP	0.26	0.27	0.28	0.29	0.30	0.30	0.32	0.33	0.34	0.35				
48115	30 - 60 (17 - 33)	Med-Low	Pink	Alternate Cooling Alternate Gas Heating	CFM	1658	1622	1585	1549	1512	1476	1442	1402	1360	1322		
					BHP	0.39	0.40	0.41	0.42	0.44	0.45	0.46	0.47	0.48	0.49		
					Gas Heat Rise (°F)	52	53	55	56	57	59	60	NA	NA	NA		
					Gas Heat Rise (°C)	29	30	30	31	32	33	33	NA	NA	NA		
					CFM	1945	1913	1867	1829	1792	1758	1717	1688	1645	1603		
					BHP	0.58	0.59	0.61	0.63	0.64	0.65	0.67	0.68	0.69	0.71		
	High	High Static Cooling Only	Gas Heat Rise (°F)	44	45	46	47	48	49	50	51	53	54				
			Gas Heat Rise (°C)	25	25	26	26	27	27	28	28	29	30				
			CFM	2201	2172	2138	2108	2074	2041	1970	1867	1764	1634				
			BHP	0.83	0.84	0.87	0.88	0.89	0.91	0.89	0.83	0.79	0.74				

*Air delivery values are without air filter and are for dry coil (See Wet Coil Pressure Drop table).

"High Static Cooling" = Only to be used for cooling function (Not allowed for gas heating function)

¹ Factory-shipped gas heating speed

² Factory-shipped cooling speed

³ Factory-shipped continuous fan speed

"NA" = Not allowed for gas heating speed

NOTE: Duct field-supplied air filter pressure drop and wet coil pressure drop to obtain static pressure available for ducting.

Shaded areas indicate speed/static combinations that are not permitted for dehumidification speed.

Table 7 - Dry Coil Air Delivery* - Horizontal and Downflow Discharge - Sizes 24-60 230VAC 1-Phase (Cont)

Unit Size	Heating Rise of (°C)	Motor Speed	Tap	Allowable Functions	ESP (in. W.C.)											
					0.1	0.2	0.3	0.4	0.5	0.6	0.7	0.8	0.9	1		
48130		Low ³	Blue		CFM	644	552	461	376	301	235	x	x	x	x	
					BHP	0.06	0.07	0.07	0.08	0.08	0.09	x	x	x	x	
					Gas Heat Rise (°F)	NA	NA	NA	NA	NA	NA	NA	NA	NA	NA	NA
					Gas Heat Rise (°C)	NA	NA	NA	NA	NA	NA	NA	NA	NA	NA	NA
					CFM	1430	1386	1347	1302	1258	1208	1160	1114	1065	1014	
					BHP	0.26	0.27	0.28	0.29	0.30	0.30	0.32	0.33	0.34	0.35	
	35 - 65 (19 - 36)	Alternate Cooling	Med-Low	Pink		Gas Heat Rise (°F)	NA	NA	NA	NA	NA	NA	NA	NA	NA	NA
						Gas Heat Rise (°C)	NA	NA	NA	NA	NA	NA	NA	NA	NA	
						CFM	1658	1622	1585	1549	1512	1476	1442	1402	1360	1322
						BHP	0.39	0.40	0.41	0.42	0.44	0.45	0.46	0.47	0.48	0.49
						Gas Heat Rise (°F)	58	59	61	62	63	65	NA	NA	NA	NA
						Gas Heat Rise (°C)	32	33	34	34	35	36	NA	NA	NA	NA
60090	35 - 65 (19 - 36)	Med-High ¹	Orange	Gas Heating Alternate Cooling	CFM	1945	1913	1867	1829	1792	1758	1717	1688	1645	1603	
					BHP	0.58	0.59	0.61	0.63	0.64	0.65	0.67	0.68	0.69	0.71	
					Gas Heat Rise (°F)	49	50	51	52	54	55	56	57	58	60	
					Gas Heat Rise (°C)	27	28	29	29	30	30	31	32	32	33	
					CFM	2201	2172	2138	2108	2074	2041	1970	1867	1764	1634	
					BHP	0.83	0.84	0.87	0.88	0.89	0.91	0.89	0.83	0.79	0.74	
			Low ³	Blue		CFM	839	768	697	625	551	486	422	360	306	x
						BHP	0.09	0.10	0.10	0.11	0.12	0.12	0.13	0.14	0.14	x
						Gas Heat Rise (°F)	NA	NA	NA	NA	NA	NA	NA	NA	NA	NA
						Gas Heat Rise (°C)	NA	NA	NA	NA	NA	NA	NA	NA	NA	NA
						CFM	1403	1361	1320	1276	1236	1192	1145	1099	1054	1012
						BHP	0.28	0.29	0.30	0.31	0.31	0.33	0.34	0.35	0.36	0.37
60090	35 - 65 (19 - 36)	Med-Low ¹	Pink	Gas Heating	Gas Heat Rise (°F)	48	50	51	53	55	57	59	62	64	NA	
					Gas Heat Rise (°C)	27	28	28	29	30	32	33	34	36	NA	
					CFM	1822	1788	1757	1726	1690	1657	1623	1589	1553	1518	
					BHP	0.54	0.55	0.56	0.57	0.59	0.60	0.61	0.62	0.63	0.64	
					Gas Heat Rise (°F)	37	38	39	39	40	41	42	43	44	45	
					Gas Heat Rise (°C)	21	21	21	22	22	23	23	24	24	25	
			Med-High	Orange	Alternate Cooling	CFM	1982	1940	1900	1859	1816	1775	1739	1701	1655	1596
						BHP	0.61	0.62	0.63	0.65	0.66	0.67	0.69	0.70	0.71	0.73
						Gas Heat Rise (°F)	NA	NA	NA	NA	NA	NA	NA	NA	NA	NA
						Gas Heat Rise (°C)	NA	NA	NA	NA	NA	NA	NA	NA	NA	NA
						CFM	2271	2241	2206	2171	2134	2080	1973	1857	1746	1596
						BHP	0.90	0.91	0.93	0.95	0.96	0.95	0.90	0.84	0.78	0.73

*Air delivery values are without air filter and are for dry coil (See Wet Coil Pressure Drop table).

"High Static Cooling" = Only to be used for cooling function (Not allowed for gas heating function)

¹ Factory-shipped gas heating speed

² Factory-shipped cooling speed

³ Factory-shipped continuous fan speed

"NA" = Not allowed for gas heating speed

NOTE: Ductwork field-supplied air filter pressure drop and wet coil pressure drop to obtain static pressure available for ducting.

Shaded areas indicate speed/static combinations that are not permitted for dehumidification speed.

Table 7 - Dry Coil Air Delivery* - Horizontal and Downflow Discharge - Sizes 24-60 230VAC 1-Phase (Cont)

Unit Size	Heating Rise of (°C)	Motor Speed	Tap	Allowable Functions	ESP (in. W.C.)											
					0.1	0.2	0.3	0.4	0.5	0.6	0.7	0.8	0.9	1		
60115	30 - 60 (17 - 33)	Low ³	Blue		CFM	839	768	697	625	551	486	422	360	306	x	
					BHP	0.09	0.10	0.10	0.11	0.12	0.12	0.13	0.14	0.14	x	
					Gas Heat Rise (°F)	NA	NA	NA	NA	NA	NA	NA	NA	NA	NA	NA
					Gas Heat Rise (°C)	NA	NA	NA	NA	NA	NA	NA	NA	NA	NA	NA
					CFM	1403	1361	1320	1276	1236	1192	1145	1099	1054	1012	
					BHP	0.28	0.29	0.30	0.31	0.31	0.33	0.34	0.35	0.36	0.37	
	60130	35 - 65 (19 - 36)	Med - Low	Pink		Gas Heat Rise (°F)	NA	NA	NA	NA	NA	NA	NA	NA	NA	NA
						Gas Heat Rise (°C)	NA	NA	NA	NA	NA	NA	NA	NA	NA	
						CFM	1822	1788	1757	1726	1690	1657	1623	1589	1553	1518
						BHP	0.54	0.55	0.56	0.57	0.59	0.60	0.61	0.62	0.63	0.64
						Gas Heat Rise (°F)	53	54	55	56	57	58	59	60	62	63
						Gas Heat Rise (°C)	29	30	30	31	32	32	33	34	34	35
60130	35 - 65 (19 - 36)	Med - High ¹	Orange	Gas Heating Alternate Cooling	CFM	1982	1940	1900	1859	1816	1775	1739	1701	1655	1596	
					BHP	0.61	0.62	0.63	0.65	0.66	0.67	0.69	0.70	0.71	0.73	
					Gas Heat Rise (°F)	44	45	45	46	48	49	50	51	52	54	
					Gas Heat Rise (°C)	24	25	25	26	26	27	28	28	29	30	
					CFM	2271	2241	2206	2171	2134	2080	1973	1857	1746	1596	
					BHP	0.90	0.91	0.93	0.95	0.96	0.95	0.90	0.84	0.78	0.73	
	60130	35 - 65 (19 - 36)	High	Black	High Static Cooling Only	CFM	839	768	697	625	551	486	422	360	306	x
						BHP	0.09	0.10	0.10	0.11	0.12	0.12	0.13	0.14	0.14	x
						Gas Heat Rise (°F)	NA	NA	NA	NA	NA	NA	NA	NA	NA	NA
						Gas Heat Rise (°C)	NA	NA	NA	NA	NA	NA	NA	NA	NA	NA
						CFM	1403	1361	1320	1276	1236	1192	1145	1099	1054	1012
						BHP	0.28	0.29	0.30	0.31	0.31	0.33	0.34	0.35	0.36	0.37
60130	35 - 65 (19 - 36)	Med - Low	Pink	Cooling Alternate Gas Heating	CFM	1822	1788	1757	1726	1690	1657	1623	1589	1553	1518	
					BHP	0.54	0.55	0.56	0.57	0.59	0.60	0.61	0.62	0.63	0.64	
					Gas Heat Rise (°F)	53	54	55	56	57	58	59	60	62	63	
					Gas Heat Rise (°C)	29	30	30	31	32	32	33	34	34	35	
					CFM	1982	1940	1900	1859	1816	1775	1739	1701	1655	1596	
					BHP	0.61	0.62	0.63	0.65	0.66	0.67	0.69	0.70	0.71	0.73	
	60130	35 - 65 (19 - 36)	High	Black	High Static Cooling Only	Gas Heat Rise (°F)	48	49	50	52	53	54	55	56	58	60
						Gas Heat Rise (°C)	27	27	28	29	29	30	31	31	32	33
						CFM	2271	2241	2206	2171	2134	2080	1973	1857	1746	1596
						BHP	0.90	0.91	0.93	0.95	0.96	0.95	0.90	0.84	0.78	0.73

*Air delivery values are without air filter and are for dry coil (See Wet Coil Pressure Drop table).

"High Static Cooling" = Only to be used for cooling function (Not allowed for gas heating function)

¹ Factory-shipped gas heating speed

² Factory-shipped cooling speed

³ Factory-shipped continuous fan speed

"NA" = Not allowed for gas heating speed

NOTE: Duct field-supplied air filter pressure drop and wet coil pressure drop to obtain static pressure available for ducting.

Shaded areas indicate speed/static combinations that are not permitted for dehumidification speed.

Table 8 – Dry Coil Air Delivery CFM* – Horizontal Discharge – Sizes 36–60 3 Phase Models Only

Unit	Heating Rise Range	Motor Speed	Wire Color		External Static Pressure (IN. W.C.)										
					0.1	0.2	0.3	0.4	0.5	0.6	0.7	0.8	0.9		
36060	25 – 55°F (14 – 31°C)	Low	Blue	CFM	983	848	764	693	612	542	509	450	374		
				Heating Rise (°F)	44	51	NA	NA	NA	NA	NA	NA	NA	NA	NA
				Heating Rise (°C)	25	28	NA	NA	NA	NA	NA	NA	NA	NA	NA
		Med – Low ¹	Pink	CFM	1008	901	838	757	693	618	550	532	471		
				Heating Rise (°F)	43	48	52	NA	NA	NA	NA	NA	NA	NA	
				Heating Rise (°C)	24	27	29	NA	NA	NA	NA	NA	NA	NA	
	Medium ²	Red	CFM	1222	1236	1195	1148	1101	1052	1004	957	916			
			Heating Rise (°F)	35	35	36	38	39	41	43	45	47			
			Heating Rise (°C)	20	19	20	21	22	23	24	25	26			
	36090	35 – 65°F (19 – 36°C)	Med – High	Orange	CFM	1311	1242	1219	1161	1098	1032	969	907	841	
					Heating Rise (°F)	33	35	36	37	39	42	45	48	52	
					Heating Rise (°C)	18	19	20	21	22	23	25	27	29	
High			Black	CFM	1536	1470	1405	1333	1263	1204	1239	1181	1122		
				Heating Rise (°F)	28	29	31	33	34	36	35	37	39		
				Heating Rise (°C)	16	16	17	18	19	20	19	20	21		
Low	Blue	CFM	983	848	764	693	612	542	509	450	374				
		Heating Rise (°F)	NA	NA	NA	NA	NA	NA	NA	NA	NA				
		Heating Rise (°C)	NA	NA	NA	NA	NA	NA	NA	NA	NA				
36090	35 – 65°F (19 – 36°C)	Med – Low	Pink	CFM	1008	901	838	757	693	618	550	532	471		
				Heating Rise (°F)	NA	NA	NA	NA	NA	NA	NA	NA	NA		
				Heating Rise (°C)	NA	NA	NA	NA	NA	NA	NA	NA	NA		
		Medium ²	Red	CFM	1222	1236	1195	1148	1101	1052	1004	957	916		
				Heating Rise (°F)	55	54	56	58	61	64	64	64	64		
				Heating Rise (°C)	30	30	31	32	34	35	35	35	35		
Med – High ¹	Orange	CFM	1311	1242	1219	1161	1098	1032	969	907	841				
		Heating Rise (°F)	51	54	55	58	61	65	65	65	65				
		Heating Rise (°C)	28	30	30	32	34	36	36	36	36				
High ¹	Black	CFM	1536	1470	1405	1333	1263	1204	1239	1181	1122				
		Heating Rise (°F)	44	46	48	50	53	56	54	57	60				
		Heating Rise (°C)	24	25	26	28	29	31	31	30	33				

Table 8 - Dry Coil Air Delivery CFM* - Horizontal Discharge - Sizes 36-60 3-Phase Models Only (Cont)

Unit	Heating Rise Range	Motor Speed	Wire Color		External Static Pressure (IN. W.C.)									
					0.1	0.2	0.3	0.4	0.5	0.6	0.7	0.8	0.9	
42060	25 – 55°F (14 – 31°C)	Low	Blue	CFM	952	882	806	746	671	605	530	551	486	
				Heating Rise (°F)	46	49	54	NA	NA	NA	NA	NA	NA	
				Heating Rise (°C)	25	27	30	NA	NA	NA	NA	NA	NA	
		Med – Low ¹	Pink	CFM	1002	936	875	821	748	687	613	554	565	
				Heating Rise (°F)	43	46	50	53	NA	NA	NA	NA	NA	
				Heating Rise (°C)	24	26	28	29	NA	NA	NA	NA	NA	
	Med – High ²	Red	Medium	CFM	1255	1210	1145	1074	1008	940	878	895	838	
				Heating Rise (°F)	35	36	38	40	43	46	49	48	52	
				Heating Rise (°C)	19	20	21	22	24	26	27	27	29	
		Orange	High	CFM	1335	1267	1246	1176	1109	1049	988	926	872	
				Heating Rise (°F)	32	34	35	37	39	41	44	47	50	
				Heating Rise (°C)	18	19	19	20	22	23	24	26	28	
42090	35 – 65°F (19 – 36°C)	Low	Blue	CFM	1472	1401	1326	1251	1275	1198	1139	1085	1023	
				Heating Rise (°F)	29	31	33	35	34	36	38	40	42	
				Heating Rise (°C)	16	17	18	19	19	20	21	22	24	
		Med – Low	Pink	CFM	952	882	806	746	671	605	530	551	486	
				Heating Rise (°F)	NA	NA	NA	NA	NA	NA	NA	NA	NA	
				Heating Rise (°C)	NA	NA	NA	NA	NA	NA	NA	NA	NA	
	Med – High ²	Red	Medium ¹	CFM	1002	936	875	821	748	687	613	554	565	
				Heating Rise (°F)	NA	NA	NA	NA	NA	NA	NA	NA	NA	
				Heating Rise (°C)	NA	NA	NA	NA	NA	NA	NA	NA	NA	
		Orange	High	CFM	1255	1210	1145	1074	1008	940	878	895	838	
				Heating Rise (°F)	53	55	58	62	NA	NA	NA	NA	NA	
				Heating Rise (°C)	30	31	32	35	NA	NA	NA	NA	NA	
42090	35 – 65°F (19 – 36°C)	Med – High ²	Orange	CFM	1335	1267	1246	1176	1109	1049	988	926	872	
				Heating Rise (°F)	50	53	54	57	60	64	NA	NA	NA	
				Heating Rise (°C)	28	29	30	32	34	35	NA	NA	NA	
		Black	High	CFM	1472	1401	1326	1251	1275	1198	1139	1085	1023	
				Heating Rise (°F)	45	48	50	53	52	56	59	62	65	
				Heating Rise (°C)	25	27	28	30	29	31	33	34	36	

Table 8 - Dry Coil Air Delivery CFM* - Horizontal Discharge - Sizes 36-60 3-Phase Models Only (Cont)

Unit	Heating Rise Range	Motor Speed	Wire Color	CFM	External Static Pressure (IN. W.C.)									
					0.1	0.2	0.3	0.4	0.5	0.6	0.7	0.8	0.9	
48090	35 – 65°F (19 – 36°C)	Low ¹	Blue	CFM	1402	1351	1311	1283	1224	1172	1136	1080	1041	
				Heating Rise (°F)	48	50	51	53	55	57	59	62	64	
		Med – Low	Pink	CFM	27	28	28	29	30	32	33	34	36	
				Heating Rise (°C)	1457	1404	1367	1318	1284	1233	1197	1144	1104	
		Medium ²	Red	Heating Rise (°F)	46	48	49	51	52	54	56	58	61	
				Heating Rise (°C)	2736	1695	1642	1601	1553	1512	1465	1427	1381	
		Med – High	Orange	Heating Rise (°F)	39	39	41	42	43	44	46	47	48	
				Heating Rise (°C)	21	22	23	23	24	25	25	26	27	
		High	Black	CFM	2149	2111	2062	2026	1980	1945	1905	1864	1793	
				Heating Rise (°F)	NA	NA	NA	NA	NA	NA	NA	NA	NA	
Low	Blue	Heating Rise (°C)	NA	NA	NA	NA	NA	NA	NA	NA	NA			
		CFM	2344	2306	2259	2203	2141	2070	1991	1902	1803			
Med – Low	Pink	Heating Rise (°F)	NA	NA	NA	NA	NA	NA	NA	NA	NA			
		Heating Rise (°C)	1402	1351	1311	1263	1224	1172	1136	1080	1041			
Medium ²	Red	CFM	1402	1351	1311	1263	1224	1172	1136	1080	1041			
		Heating Rise (°F)	NA	NA	NA	NA	NA	NA	NA	NA	NA			
Med – High ¹	Orange	Heating Rise (°C)	NA	NA	NA	NA	NA	NA	NA	NA	NA			
		CFM	1457	1404	1367	1318	1284	1233	1197	1144	1104			
High	Black	Heating Rise (°F)	58	NA	NA	NA	NA	NA	NA	NA	NA			
		Heating Rise (°C)	32	NA	NA	NA	NA	NA	NA	NA	NA			
48115	30 – 60°F (17 – 33°C)	Low	Blue	CFM	1736	1695	1642	1601	1553	1512	1465	1427	1381	
				Heating Rise (°F)	49	50	52	53	55	56	58	60	NA	
		Med – Low	Pink	Heating Rise (°C)	27	28	29	30	30	31	32	33	NA	
				CFM	2149	2111	2062	2026	1980	1945	1905	1864	1793	
		Medium ²	Red	Heating Rise (°F)	40	40	41	42	43	44	45	46	48	
				Heating Rise (°C)	22	22	23	23	24	24	25	25	26	
		Med – High ¹	Orange	CFM	2344	2306	2259	2203	2141	2070	1991	1902	1803	
				Heating Rise (°F)	36	37	38	39	40	41	43	45	47	
		High	Black	Heating Rise (°C)	20	21	21	21	22	23	24	25	26	

Table 8 - Dry Coil Air Delivery CFM* - Horizontal Discharge - Sizes 36-60 3-Phase Models Only (Cont)

Unit	Heating Rise Range	Motor Speed	Wire Color	CFM	External Static Pressure (IN. W.C.)										
					0.1	0.2	0.3	0.4	0.5	0.6	0.7	0.8	0.9		
48130	35 – 65°F (19 – 36°C)	Low	Blue	CFM	1402	1351	1311	1263	1224	1172	1136	1080	1041		
				Heating Rise (°F)	NA	NA	NA	NA	NA	NA	NA	NA	NA	NA	
		Med – Low	Pink	CFM	1457	1404	1367	1318	1284	1233	1197	1144	1104		
				Heating Rise (°F)	65	NA	NA	NA	NA	NA	NA	NA	NA	NA	
		Medium ²	Red	CFM	1736	1695	1642	1601	1553	1512	1465	1427	1381		
				Heating Rise (°F)	55	56	58	59	61	63	65	NA	NA		
		Med – High ¹	Orange	CFM	2149	2111	2062	2026	1980	1945	1905	1864	1793		
				Heating Rise (°F)	44	45	46	47	48	49	50	51	53		
		60090	35 – 65°F (19 – 36°C)	High	Black	CFM	2344	2306	2259	2203	2141	2070	1991	1902	1803
						Heating Rise (°F)	41	41	42	43	44	46	48	50	53
Low ¹	Blue			CFM	1445	1389	1341	1281	1236	1189	1139	1072	1027		
				Heating Rise (°F)	46	48	50	52	54	56	59	62	65		
Med – Low	Pink			CFM	1678	1635	1602	1558	1513	1474	1438	1404	1349		
				Heating Rise (°F)	40	41	42	43	44	45	47	48	50		
Medium ²	Red			CFM	1962	1915	1880	1843	1794	1753	1711	1675	1628		
				Heating Rise (°F)	NA	35	36	36	37	38	39	40	41		
Med – High	Orange			CFM	2131	2088	2065	2013	1982	1941	1888	1860	1785		
				Heating Rise (°F)	NA	NA	NA	NA	NA	NA	35	36	37		
High	Black	CFM	2461	2409	2339	2286	2192	2140	2062	1968	1874				
		Heating Rise (°F)	NA	NA	NA	NA	NA	NA	NA	NA	36				
				Heating Rise (°C)	NA	NA	NA	NA	NA	NA	NA	NA			

Table 8 - Dry Coil Air Delivery CFM* - Horizontal Discharge - Sizes 36-60 3-Phase Models Only (Cont)

Unit	Heating Rise Range	Motor Speed	Wire Color		External Static Pressure (IN. W.C.)									
					0.1	0.2	0.3	0.4	0.5	0.6	0.7	0.8	0.9	
60115	CFM	Low	Blue		1445	1389	1341	1281	1236	1189	1139	1072	1027	
					Heating Rise (°F)	59	NA	NA	NA	NA	NA	NA	NA	NA
	CFM	Med-Low	Pink		1678	1635	1602	1558	1513	1474	1438	1404	1349	
					Heating Rise (°F)	51	52	53	55	56	58	59	NA	NA
	CFM	Medium ²	Red		1962	1915	1880	1843	1794	1753	1711	1675	1628	
					Heating Rise (°F)	43	44	45	46	47	49	50	51	52
	CFM	Med-High ¹	Orange		2131	2088	2065	2013	1982	1941	1888	1860	1785	
					Heating Rise (°F)	40	41	41	42	43	44	45	46	48
	60130	CFM	High	Black		2461	2409	2339	2286	2192	2140	2062	1968	1874
						Heating Rise (°F)	35	35	36	37	39	40	41	43
CFM		Low	Blue		1445	1389	1341	1281	1236	1189	1139	1072	1027	
					Heating Rise (°F)	NA	NA	NA	NA	NA	NA	NA	NA	NA
CFM		Med-Low	Pink		1678	1635	1602	1558	1513	1474	1438	1404	1349	
					Heating Rise (°F)	57	58	59	61	63	65	NA	NA	NA
CFM		Medium ²	Red		1962	1915	1880	1843	1794	1753	1711	1675	1628	
					Heating Rise (°F)	49	50	51	52	53	54	56	57	58
CFM		Med-High ¹	Orange		2131	2088	2065	2013	1982	1941	1888	1860	1785	
					Heating Rise (°F)	45	46	46	47	48	49	50	51	53
CFM	High	Black		2461	2409	2339	2286	2192	2140	2062	1968	1874		
				Heating Rise (°F)	39	40	41	42	43	44	46	48	51	
					21	22	23	23	24	25	26	27	28	

* Air delivery values are without air filter and are for dry coil (See Wet Coil Pressure Drop table).

1 Factory-shipped heating speed

2 Factory-shipped cooling speed

NA - Not allowed for heating speed

Note: Ductwork field-supplied air filter pressure drop and wet coil pressure drop to obtain external static pressure available for ducting.

Shaded areas indicate speed/static combinations that are not permitted for dehumidification speed.

Table 9 – Dry Coil Air Delivery CFM* - Downflow Discharge - 3 Phase Only

Unit	Heating Rise Range	Motor Speed	Wire Color	External Static Pressure (IN. W.C.)											
				0.1	0.2	0.3	0.4	0.5	0.6	0.7	0.8	0.9	1.0		
36060	25 – 55°F (14 – 31°C)	Low	Blue	CFM	983	848	764	693	612	542	509	450	374	---	
				WATTS	115	107	113	123	128	138	144	154	159	---	
				BHP	0.12	0.11	0.12	0.13	0.14	0.15	0.15	0.17	0.17	---	
				Heating Rise (°F)	44	51	NA	NA	NA	NA	NA	NA	NA	NA	
				Heating Rise (°C)	24	28	NA	NA	NA	NA	NA	NA	NA	NA	
				CFM	1008	901	888	757	693	618	550	532	471	402	
				WATTS	123	121	132	137	148	154	164	170	181	185	
				BHP	0.13	0.13	0.14	0.15	0.16	0.17	0.18	0.18	0.19	0.20	
				Heating Rise (°F)	43	48	52	NA	NA	NA	NA	NA	NA	NA	
				Heating Rise (°C)	24	27	29	NA	NA	NA	NA	NA	NA	NA	
	Med – Low ¹	Pink	Medium ²	Red	CFM	1222	1236	1195	1148	1101	1052	1004	957	916	868
					WATTS	233	221	232	244	251	264	275	285	291	304
					BHP	0.25	0.24	0.25	0.26	0.27	0.28	0.29	0.31	0.31	0.33
					Heating Rise (°F)	35	35	36	38	39	41	43	45	47	50
					Heating Rise (°C)	20	19	20	21	22	23	24	25	26	28
					CFM	1311	1242	1219	1161	1098	1032	969	907	841	859
					WATTS	256	270	283	289	301	313	320	331	343	349
					BHP	0.27	0.29	0.30	0.31	0.32	0.34	0.34	0.35	0.37	0.37
					Heating Rise (°F)	33	35	36	37	39	42	45	48	51	50
					Heating Rise (°C)	18	19	20	21	22	23	25	27	29	28
Med – High	Orange	High	Black	CFM	1536	1470	1405	1333	1263	1204	1239	1181	1122	1055	
				WATTS	411	423	429	441	453	464	473	477	488	489	
				BHP	0.44	0.45	0.46	0.47	0.49	0.50	0.51	0.51	0.52	0.52	
				Heating Rise (°F)	NA	NA	31	32	34	36	35	37	39	41	
				Heating Rise (°C)	NA	NA	17	18	19	20	19	20	21	23	

Table 9 - Dry Coil Air Delivery CFM* - Downflow Discharge - 3 Phase Only (Cont)

Unit	Heating Rise Range	Motor Speed	Wire Color	External Static Pressure (IN. W.C.)										
				0.1	0.2	0.3	0.4	0.5	0.6	0.7	0.8	0.9	1.0	
36090	35 - 65°F (19 - 36°C)	Low	Blue	CFM	983	848	764	693	612	542	509	450	374	---
				WATTS	115	107	113	123	128	138	144	154	159	---
				BHP	0.12	0.11	0.12	0.13	0.14	0.15	0.15	0.17	0.17	---
				Heating Rise (°F)	NA	NA	NA	NA	NA	NA	NA	NA	NA	NA
				Heating Rise (°C)	NA	NA	NA	NA	NA	NA	NA	NA	NA	NA
				CFM	1008	901	838	757	693	618	550	532	471	402
				WATTS	123	121	132	137	148	154	164	170	181	185
				BHP	0.13	0.13	0.14	0.15	0.16	0.17	0.18	0.18	0.19	0.20
				Heating Rise (°F)	NA	NA	NA	NA	NA	NA	NA	NA	NA	NA
				Heating Rise (°C)	NA	NA	NA	NA	NA	NA	NA	NA	NA	NA
	Med - Low	Pink	Med - Low	CFM	1222	1236	1195	1148	1101	1052	1004	957	916	868
				WATTS	256	270	283	289	301	313	320	331	343	349
				BHP	0.27	0.29	0.30	0.31	0.32	0.34	0.34	0.35	0.37	0.37
				Heating Rise (°F)	55	54	56	58	61	64	NA	NA	NA	NA
				Heating Rise (°C)	30	30	31	32	34	35	NA	NA	NA	NA
				CFM	1311	1242	1219	1161	1098	1032	969	907	841	859
				WATTS	256	270	283	289	301	313	320	331	343	349
				BHP	0.27	0.29	0.30	0.31	0.32	0.34	0.34	0.35	0.37	0.37
				Heating Rise (°F)	51	54	55	58	61	65	NA	NA	NA	NA
				Heating Rise (°C)	28	30	30	32	34	36	NA	NA	NA	NA
Med - High ¹	Orange	Med - High ¹	CFM	1536	1470	1405	1333	1263	1204	1239	1181	1122	1055	
			WATTS	411	423	429	441	453	464	473	477	488	489	
			BHP	0.44	0.45	0.46	0.47	0.49	0.50	0.51	0.51	0.52	0.52	
			Heating Rise (°F)	44	46	48	50	53	56	54	57	60	63	
			Heating Rise (°C)	24	25	26	28	29	31	30	31	33	35	

Table 9 - Dry Coil Air Delivery CFM* - Downflow Discharge - 3 Phase Only (Cont)

Unit	Heating Rise Range	Motor Speed	Wire Color	External Static Pressure (IN. W.C.)										
				0.1	0.2	0.3	0.4	0.5	0.6	0.7	0.8	0.9	1.0	
42060	25 - 55°F (14 - 31°C)	Low	Blue	CFM	952	882	806	746	671	605	530	551	486	435
				WATTS	124	134	140	150	156	166	171	182	188	198
				BHP	0.13	0.14	0.15	0.16	0.17	0.18	0.18	0.20	0.20	0.21
				Heating Rise (°F)	45	49	54	NA	NA	NA	NA	NA	NA	NA
				Heating Rise (°C)	25	27	30	NA	NA	NA	NA	NA	NA	NA
				CFM	1002	936	875	821	748	687	613	554	565	518
				WATTS	144	155	161	171	176	187	193	203	209	220
				BHP	0.15	0.17	0.17	0.18	0.19	0.20	0.21	0.22	0.22	0.24
				Heating Rise (°F)	43	46	49	53	NA	NA	NA	NA	NA	NA
				Heating Rise (°C)	24	26	27	29	NA	NA	NA	NA	NA	NA
				CFM	1255	1210	1145	1074	1008	940	878	895	838	785
				WATTS	249	272	284	292	305	319	320	329	336	347
				BHP	0.27	0.29	0.30	0.31	0.33	0.34	0.34	0.35	0.36	0.37
				Heating Rise (°F)	35	36	38	40	43	46	49	48	52	55
				Heating Rise (°C)	19	20	21	22	24	26	27	27	29	31
				CFM	1335	1267	1246	1176	1109	1049	988	926	872	891
				WATTS	311	323	330	342	356	367	378	385	395	403
				BHP	0.33	0.35	0.35	0.37	0.38	0.39	0.41	0.41	0.42	0.43
				Heating Rise (°F)	32	34	35	37	39	41	44	47	50	49
				Heating Rise (°C)	18	19	19	20	22	23	24	26	28	27
CFM	1472	1401	1326	1251	1275	1198	1139	1085	1023	961				
WATTS	401	414	426	440	471	462	473	478	486	491				
BHP	0.43	0.44	0.46	0.47	0.51	0.50	0.51	0.51	0.52	0.53				
Heating Rise (°F)	29	31	33	35	34	36	38	40	42	45				
Heating Rise (°C)	16	17	18	19	19	20	21	22	24	25				

Table 9 - Dry Coil Air Delivery CFM* - Downflow Discharge - 3 Phase Only (Cont)

Unit	Heating Rise Range	Motor Speed	Wire Color	External Static Pressure (IN. W.C.)											
				0.1	0.2	0.3	0.4	0.5	0.6	0.7	0.8	0.9	1.0		
42090	35 - 65°F (19 - 36°C)	Low	Blue	CFM	952	882	806	746	671	605	530	551	486	435	
				WATTS	124	134	140	150	156	166	171	182	188	198	
				BHP	0.13	0.14	0.15	0.16	0.17	0.18	0.18	0.20	0.20	0.21	
				Heating Rise (°F)	NA	NA	NA	NA	NA	NA	NA	NA	NA	NA	NA
				Heating Rise (°C)	NA	NA	NA	NA	NA	NA	NA	NA	NA	NA	NA
				CFM	1002	936	875	821	748	687	613	554	565	518	
				WATTS	144	155	161	171	176	187	193	203	209	220	
				BHP	0.15	0.17	0.17	0.18	0.19	0.20	0.21	0.22	0.22	0.24	
				Heating Rise (°F)	NA	NA	NA	NA	NA	NA	NA	NA	NA	NA	
				Heating Rise (°C)	NA	NA	NA	NA	NA	NA	NA	NA	NA	NA	
				CFM	1255	1210	1145	1074	1008	940	878	895	838	785	
				WATTS	249	272	284	292	305	319	320	329	336	347	
				BHP	0.27	0.29	0.30	0.31	0.33	0.34	0.34	0.35	0.36	0.37	
				Heating Rise (°F)	53	55	58	62	NA	NA	NA	NA	NA	NA	
				Heating Rise (°C)	30	31	32	35	NA	NA	NA	NA	NA	NA	
				CFM	1335	1267	1246	1176	1109	1049	988	926	872	891	
				WATTS	311	323	330	342	356	367	378	385	395	403	
				BHP	0.33	0.35	0.35	0.37	0.38	0.39	0.41	0.41	0.42	0.43	
				Heating Rise (°F)	50	53	54	57	60	64	NA	NA	NA	NA	
				Heating Rise (°C)	28	29	30	32	34	35	NA	NA	NA	NA	
CFM	1472	1401	1326	1251	1275	1198	1139	1085	1023	961					
WATTS	401	414	426	440	471	462	473	478	486	491					
BHP	0.43	0.44	0.46	0.47	0.51	0.50	0.51	0.51	0.52	0.53					
Heating Rise (°F)	45	48	50	53	52	56	59	62	65	NA					
Heating Rise (°C)	25	27	28	30	29	31	33	34	36	NA					

Table 9 - Dry Coil Air Delivery CFM* - Downflow Discharge - 3 Phase Only (Cont)

Unit	Heating Rise Range	Motor Speed	Wire Color	External Static Pressure (IN. W.C.)														
				0.1	0.2	0.3	0.4	0.5	0.6	0.7	0.8	0.9	1.0					
48090	35 - 65°F (19 - 36°C)	Low ¹	Blue	CFM	1503	1457	1423	1374	1330	1287	1241	1199	1153	1111				
				WATTS	225	233	246	254	269	282	292	307	314	329				
				BHP	0.24	0.25	0.26	0.27	0.29	0.30	0.31	0.33	0.34	0.35				
				Heating Rise (°F)	45	46	47	49	50	52	54	56	58	60				
				Heating Rise (°C)	25	26	26	27	28	29	30	31	32	33				
				CFM	1556	1508	1461	1432	1388	1346	1302	1256	1221	1168				
				WATTS	244	261	268	281	290	305	319	330	345	353				
				BHP	0.26	0.28	0.29	0.30	0.31	0.33	0.34	0.35	0.37	0.38				
				Heating Rise (°F)	43	44	46	47	48	50	51	53	55	57				
				Heating Rise (°C)	24	25	25	26	27	28	29	30	30	32				
	Med - Low	Pink	Med - Low	Pink	CFM	1861	1822	1786	1758	1716	1688	1660	1619	1583	1539			
					WATTS	400	417	426	441	452	467	482	492	507	519			
					BHP	0.43	0.45	0.46	0.47	0.48	0.50	0.52	0.53	0.54	0.56			
					Heating Rise (°F)	36	37	37	38	39	40	40	41	42	43			
					Heating Rise (°C)	20	20	21	21	22	22	22	23	23	24			
					CFM	2319	2291	2255	2230	2193	2166	2118	2057	1992	1887			
					WATTS	758	769	787	799	808	823	822	805	780	737			
					BHP	0.81	0.82	0.84	0.86	0.87	0.88	0.88	0.86	0.84	0.79			
					Heating Rise (°F)	NA	NA	NA	NA	NA	NA	NA	NA	NA	35			
					Heating Rise (°C)	NA	NA	NA	NA	NA	NA	NA	NA	NA	20			
Med - High	Orange	Med - High	Orange	CFM	2532	2487	2444	2391	2330	2259	2179	2111	2033	1949				
				WATTS	1014	1022	1015	994	965	935	898	858	823	786				
				BHP	1.09	1.10	1.09	1.07	1.03	1.00	0.96	0.92	0.88	0.84				
				Heating Rise (°F)	NA	NA	NA	NA	NA	NA	NA	NA	NA	NA				
				Heating Rise (°C)	NA	NA	NA	NA	NA	NA	NA	NA	NA	NA				
				High	Black	High	Black	CFM	1503	1457	1423	1374	1330	1287	1241	1199	1153	1111
								WATTS	225	233	246	254	269	282	292	307	314	329
								BHP	0.24	0.25	0.26	0.27	0.29	0.30	0.31	0.33	0.34	0.35
								Heating Rise (°F)	45	46	47	49	50	52	54	56	58	60
								Heating Rise (°C)	25	26	26	27	28	29	30	31	32	33
CFM	1556	1508	1461					1432	1388	1346	1302	1256	1221	1168				
WATTS	244	261	268					281	290	305	319	330	345	353				
BHP	0.26	0.28	0.29					0.30	0.31	0.33	0.34	0.35	0.37	0.38				
Heating Rise (°F)	43	44	46					47	48	50	51	53	55	57				
Heating Rise (°C)	24	25	25					26	27	28	29	30	30	32				

Table 9 - Dry Coil Air Delivery CFM* - Downflow Discharge - 3 Phase Only (Cont)

Unit	Heating Rise Range	Motor Speed	Wire Color	External Static Pressure (IN. W.C.)											
				0.1	0.2	0.3	0.4	0.5	0.6	0.7	0.8	0.9	1.0		
48115	30 - 60°F (17 - 33°C)	Low	Blue	CFM	1503	1457	1423	1374	1330	1287	1241	1199	1153	1111	
				WATTS	225	233	246	254	269	282	292	307	314	329	
				BHP	0.24	0.25	0.26	0.27	0.29	0.30	0.31	0.33	0.34	0.35	
				Heating Rise (°F)	57	58	60	NA	NA	NA	NA	NA	NA	NA	NA
				Heating Rise (°C)	31	32	33	NA	NA	NA	NA	NA	NA	NA	NA
				CFM	1556	1508	1461	1432	1388	1346	1302	1256	1221	1168	
		WATTS	244	261	268	281	290	305	319	330	345	353			
		BHP	0.26	0.28	0.29	0.30	0.31	0.33	0.34	0.35	0.37	0.38			
		Heating Rise (°F)	55	56	58	59	NA	NA	NA	NA	NA	NA			
		Heating Rise (°C)	30	31	32	33	NA	NA	NA	NA	NA	NA			
		CFM	1861	1822	1786	1758	1716	1688	1660	1619	1583	1539			
		WATTS	400	417	426	441	452	467	482	492	507	519			
		BHP	0.43	0.45	0.46	0.47	0.48	0.50	0.52	0.53	0.54	0.56			
		Heating Rise (°F)	46	47	48	48	50	50	51	53	54	55			
		Heating Rise (°C)	25	26	26	27	28	28	29	29	30	31			
		CFM	2319	2291	2255	2230	2193	2166	2118	2057	1992	1887			
		WATTS	758	769	787	799	808	823	822	805	780	737			
		BHP	0.81	0.82	0.84	0.86	0.87	0.88	0.88	0.86	0.84	0.79			
Heating Rise (°F)	37	37	38	38	39	39	40	41	43	45					
Heating Rise (°C)	20	21	21	21	22	22	22	23	24	25					
CFM	2532	2487	2444	2391	2330	2259	2179	2111	2033	1949					
WATTS	1014	1022	1015	994	965	935	898	858	823	786					
BHP	1.09	1.10	1.09	1.07	1.03	1.00	0.96	0.92	0.88	0.84					
Heating Rise (°F)	34	34	35	36	37	38	39	40	42	44					
Heating Rise (°C)	19	19	19	20	20	21	22	22	23	24					

Table 9 - Dry Coil Air Delivery CFM* - Downflow Discharge - 3 Phase Only (Cont)

Unit	Heating Rise Range	Motor Speed	Wire Color	External Static Pressure (IN. W.C.)											
				0.1	0.2	0.3	0.4	0.5	0.6	0.7	0.8	0.9	1.0		
48130	35 - 65°F (19 - 36°C)	Low	Blue	CFM	1503	1457	1423	1374	1330	1287	1241	1199	1153	1111	
				WATTS	225	233	246	254	269	282	292	307	314	329	
				BHP	0.24	0.25	0.26	0.27	0.29	0.30	0.31	0.33	0.34	0.35	
				Heating Rise (°F)	63	65	NA	NA	NA	NA	NA	NA	NA	NA	NA
				Heating Rise (°C)	35	36	NA	NA	NA	NA	NA	NA	NA	NA	NA
		Med-Low	Pink	CFM	1556	1508	1461	1432	1388	1346	1302	1256	1221	1168	
				WATTS	244	261	268	281	290	305	319	330	345	353	
				BHP	0.26	0.28	0.29	0.30	0.31	0.33	0.34	0.35	0.37	0.38	
				Heating Rise (°F)	61	63	65	NA	NA	NA	NA	NA	NA	NA	
				Heating Rise (°C)	34	35	36	NA	NA	NA	NA	NA	NA	NA	
	Medium ²	Red	CFM	1861	1822	1786	1758	1716	1688	1660	1619	1583	1539		
			WATTS	400	417	426	441	452	467	482	492	507	519		
			BHP	0.43	0.45	0.46	0.47	0.48	0.50	0.52	0.53	0.54	0.56		
			Heating Rise (°F)	51	52	53	54	55	56	57	59	60	62		
			Heating Rise (°C)	28	29	30	30	31	31	32	33	33	34		
			Med-High ¹	Orange	CFM	2319	2291	2255	2230	2193	2166	2118	2057	1992	1887
					WATTS	758	769	787	799	808	823	822	805	780	737
					BHP	0.81	0.82	0.84	0.86	0.87	0.88	0.88	0.86	0.84	0.79
					Heating Rise (°F)	41	42	42	43	43	44	45	46	48	50
					Heating Rise (°C)	23	23	23	24	24	24	25	26	27	28
High	Black	CFM	2532	2487	2444	2391	2330	2259	2179	2111	2033	1949			
		WATTS	1014	1022	1015	994	965	935	898	858	823	786			
		BHP	1.09	1.10	1.09	1.07	1.03	1.00	0.96	0.92	0.88	0.84			
		Heating Rise (°F)	38	38	39	40	41	42	44	45	47	49			
		Heating Rise (°C)	21	21	22	22	23	23	24	25	26	27			

Table 9 - Dry Coil Air Delivery CFM* - Downflow Discharge - 3 Phase Only (Cont)

Unit	Heating Rise Range	Motor Speed	Wire Color	External Static Pressure (IN. W.C.)														
				0.1	0.2	0.3	0.4	0.5	0.6	0.7	0.8	0.9	1.0					
60090	35 - 65°F (19 - 36°C)	Low ¹	Blue	CFM	1479	1436	1387	1346	1298	1253	1206	1160	1114	1061				
				WATTS	224	239	247	262	270	284	300	307	319	330				
				BHP	0.24	0.26	0.26	0.28	0.29	0.30	0.32	0.33	0.34	0.35				
				Heating Rise (°F)	46	47	49	51	52	54	56	59	61	64				
				Heating Rise (°C)	26	26	27	28	29	30	31	33	34	36				
				CFM	1841	1796	1761	1724	1690	1651	1616	1578	1527	1478				
				WATTS	425	434	453	460	476	485	501	508	525	542				
				BHP	0.46	0.47	0.49	0.49	0.51	0.52	0.54	0.54	0.56	0.58				
				Heating Rise (°F)	36	37	38	39	40	41	41	42	44	45				
				Heating Rise (°C)	20	21	21	22	22	23	23	24	24	25				
	Med - Low	Pink	Med - Low	Pink	CFM	1944	1913	1872	1838	1801	1771	1731	1698	1655	1613			
					WATTS	486	501	511	529	537	554	565	578	595	603			
					BHP	0.52	0.54	0.55	0.57	0.58	0.59	0.61	0.62	0.64	0.65			
					Heating Rise (°F)	34	35	36	36	37	38	39	39	40	41			
					Heating Rise (°C)	19	19	20	20	21	21	21	22	22	23			
					CFM	2178	2148	2105	2073	2036	2002	1967	1919	1845	1751			
					WATTS	674	691	703	717	733	743	758	754	734	701			
					BHP	0.72	0.74	0.75	0.77	0.79	0.80	0.81	0.81	0.79	0.75			
					Heating Rise (°F)	NA	NA	NA	NA	NA	NA	NA	NA	35	36	38		
					Heating Rise (°C)	NA	NA	NA	NA	NA	NA	NA	NA	19	20	21		
Med - High	Orange	Med - High	Orange	CFM	2480	2432	2375	2322	2236	2161	2085	2006	1917	1808				
				WATTS	1029	1012	995	975	941	908	869	836	796	751				
				BHP	1.10	1.09	1.07	1.05	1.01	0.97	0.93	0.90	0.85	0.81				
				Heating Rise (°F)	NA	NA	NA	NA	NA	NA	NA	NA	NA	35	37			
				Heating Rise (°C)	NA	NA	NA	NA	NA	NA	NA	NA	NA	19	21			
				High	Black	High	Black	CFM	1479	1436	1387	1346	1298	1253	1206	1160	1114	1061
								WATTS	224	239	247	262	270	284	300	307	319	330
								BHP	0.24	0.26	0.26	0.28	0.29	0.30	0.32	0.33	0.34	0.35
								Heating Rise (°F)	46	47	49	51	52	54	56	59	61	64
								Heating Rise (°C)	26	26	27	28	29	30	31	33	34	36
CFM	1841	1796	1761					1724	1690	1651	1616	1578	1527	1478				
WATTS	425	434	453					460	476	485	501	508	525	542				
BHP	0.46	0.47	0.49					0.49	0.51	0.52	0.54	0.54	0.56	0.58				
Heating Rise (°F)	36	37	38					39	40	41	41	42	44	45				
Heating Rise (°C)	20	21	21					22	22	23	23	24	24	25				

Table 9 - Dry Coil Air Delivery CFM* - Downflow Discharge - 3 Phase Only (Cont)

Unit	Heating Rise Range	Motor Speed	Wire Color	External Static Pressure (IN. W.C.)											
				0.1	0.2	0.3	0.4	0.5	0.6	0.7	0.8	0.9	1.0		
60115	30 - 60°F (17 - 33°C)	Low	Blue	CFM	1479	1436	1387	1346	1298	1253	1206	1160	1114	1061	
				WATTS	224	239	247	262	270	284	300	307	319	330	
				BHP	0.24	0.26	0.26	0.28	0.29	0.30	0.32	0.33	0.34	0.35	
				Heating Rise (°F)	58	59	NA	NA	NA	NA	NA	NA	NA	NA	NA
				Heating Rise (°C)	32	33	NA	NA	NA	NA	NA	NA	NA	NA	NA
				CFM	1841	1796	1761	1724	1690	1651	1616	1578	1527	1478	
		WATTS	425	434	453	460	476	485	501	508	525	542			
		BHP	0.46	0.47	0.49	0.49	0.51	0.52	0.54	0.54	0.56	0.58			
		Heating Rise (°F)	46	47	48	49	50	52	53	54	56	58			
		Heating Rise (°C)	26	26	27	27	28	29	29	30	31	32			
		CFM	1944	1913	1872	1838	1801	1771	1731	1698	1655	1613			
		WATTS	486	501	511	529	537	554	565	578	595	603			
		BHP	0.52	0.54	0.55	0.57	0.58	0.59	0.61	0.62	0.64	0.65			
		Heating Rise (°F)	44	45	46	46	47	48	49	50	51	53			
		Heating Rise (°C)	24	25	25	26	26	27	27	28	29	29			
		CFM	2178	2148	2105	2073	2036	2002	1967	1919	1845	1751			
		WATTS	674	691	703	717	733	743	758	754	734	701			
		BHP	0.72	0.74	0.75	0.77	0.79	0.80	0.81	0.81	0.79	0.75			
Heating Rise (°F)	39	40	40	41	42	43	43	44	46	49					
Heating Rise (°C)	22	22	22	23	23	24	24	25	26	27					
CFM	2480	2432	2375	2322	2236	2161	2085	2006	1917	1808					
WATTS	1029	1012	995	975	941	908	869	836	796	751					
BHP	1.10	1.09	1.07	1.05	1.01	0.97	0.93	0.90	0.85	0.81					
Heating Rise (°F)	NA	35	36	37	38	39	41	42	44	47					
Heating Rise (°C)	NA	19	20	20	21	22	23	24	25	26					

Table 9 - Dry Coil Air Delivery CFM* - Downflow Discharge - 3 Phase Only (Cont)

Unit	Heating Rise Range	Motor Speed	Wire Color	External Static Pressure (IN. W.C.)										
				0.1	0.2	0.3	0.4	0.5	0.6	0.7	0.8	0.9	1.0	
60130	35 - 65°F (19 - 36°C)	Low	Blue	CFM	1479	1436	1387	1346	1298	1253	1206	1160	1114	1061
				WATTS	224	239	247	262	270	284	300	307	319	330
				BHP	0.24	0.26	0.26	0.28	0.29	0.30	0.32	0.33	0.34	0.35
				Heating Rise (°F)	64	NA	NA	NA	NA	NA	NA	NA	NA	NA
		Heating Rise (°C)	36	NA	NA	NA	NA	NA	NA	NA	NA	NA	NA	
		CFM	1841	1796	1761	1724	1690	1651	1616	1578	1527	1478		
		WATTS	425	434	453	460	476	485	501	508	525	542		
		BHP	0.46	0.47	0.49	0.49	0.51	0.52	0.54	0.54	0.56	0.58		
		Heating Rise (°F)	52	53	54	55	56	58	59	60	62	64		
		Heating Rise (°C)	29	29	30	31	31	32	33	34	35	36		
		CFM	1944	1913	1872	1838	1801	1771	1731	1698	1655	1613		
		WATTS	486	501	511	529	537	554	565	578	595	603		
		BHP	0.52	0.54	0.55	0.57	0.58	0.59	0.61	0.62	0.64	0.65		
		Heating Rise (°F)	49	50	51	52	53	54	55	56	58	59		
		Heating Rise (°C)	27	28	28	29	29	30	31	31	32	33		
		CFM	2178	2148	2105	2073	2036	2002	1967	1919	1845	1751		
WATTS	674	691	703	717	733	743	758	754	734	701				
BHP	0.72	0.74	0.75	0.77	0.79	0.80	0.81	0.81	0.79	0.75				
Heating Rise (°F)	44	44	45	46	47	48	48	50	52	54				
Heating Rise (°C)	24	25	25	26	26	26	27	28	29	30				
CFM	2480	2432	2375	2322	2236	2161	2085	2006	1917	1808				
WATTS	1029	1012	995	975	941	908	869	836	796	751				
BHP	1.10	1.09	1.07	1.05	1.01	0.97	0.93	0.90	0.85	0.81				
Heating Rise (°F)	38	39	40	41	43	44	46	47	50	53				
Heating Rise (°C)	21	22	22	23	24	24	25	26	28	29				

* Air delivery values are without air filter and are for dry coil (See Wet Coil Pressure Drop table).

1 Factory-shipped heating speed

2 Factory-shipped cooling speed

NA - Not allowed for heating speed

Note: Ductwork field-supplied air filter pressure drop and wet coil pressure drop to obtain external static pressure available for ducting.

Note: Ductwork field-supplied air filter pressure drop and wet coil pressure drop to obtain external static pressure available for ducting. Shaded areas indicate speed/static combinations that are not permitted for dehumidification speed.

Table 10 – Filter Pressure Drop Table (IN. W.C.)

FILTER SIZE IN. (MM)	COOLING TONS	STANDARD CFM (SCFM)																
		600	700	800	900	1000	1100	1200	1300	1400	1500	1600	1700	1800	1900	2000	2100	2200
600-1400 CFM 12x20x1 + 12x20x1 (305x508x25 + 305x508x25)	2.0,	0.03	0.04	0.05	0.06	0.06	0.07	0.07	0.08	0.08	-	-	-	-	-	-	-	-
	2.5,																	
	3.0																	
1200-1800 CFM 16x24x1 + 14x24x1 (406x610x25 + 356x610x25)	3.5,	-	-	-	-	0.04	0.05	0.06	0.07	0.08	0.09	0.10	0.11	0.12	0.12	-	-	-
	4.0																	
1500-2200 CFM 16x24x1 + 18x24x1 (406x610x25 + 457x356x25)	5.0	-	-	-	-	-	-	-	-	-	0.04	0.06	0.08	0.10	0.11	0.13	0.14	0.15

Table 11 – Wet Coil Pressure Drop (IN. W.C.)

UNIT SIZE	STANDARD CFM (SCFM)																
	600	700	800	900	1000	1100	1200	1300	1400	1500	1600	1700	1800	1900	2000	2100	2200
24	0.03	0.04	0.04	0.05	0.06	0.06	0.08	0.11									
30				0.05	0.06	0.07	0.08	0.11									
36				0.06	0.06	0.09	0.10	0.11	0.14								
42					0.05	0.05	0.06	0.07	0.08	0.08	0.09	0.09	0.11				
48							0.04	0.06	0.09	0.10	0.10	0.11	0.12	0.13	0.14		
60										0.06	0.07	0.01	0.08	0.09	0.10	0.12	0.13

Table 12 – Economizer with 1-in. Filter Pressure Drop (IN. W.C.)

FILTER SIZE IN. (MM)	COOLING TONS	STANDARD CFM (SCFM)																
		600	700	800	900	1000	1100	1200	1300	1400	1500	1600	1700	1800	1900	2000	2100	2200
600-1400 CFM 12x20x1 + 12x20x1 (305x508x25 + 305x508x25)	2.0,	-	-	0.08	0.09	0.10	0.11	0.11	0.13	0.14	-	-	-	-	-	-	-	-
	2.5,																	
	3.0																	
1200-1800 CFM 16x24x1 + 14x24x1 (406x610x25 + 356x610x25)	3.5,	-	-	-	-	-	0.09	0.09	0.10	0.12	0.13	0.15	0.17	0.17	0.19	0.21	-	-
	4.0																	
1500-2200 CFM 16x24x1 + 18x24x1 (406x610x25 + 457x356x25)	5.0	-	-	-	-	-	-	-	-	-	0.15	0.17	0.18	0.20	0.21	0.22	0.23	0.23

CONNECTION WIRING DIAGRAM

DANGER: ELECTRICAL SHOCK HAZARD DISCONNECT POWER BEFORE SERVICING

SCHEMATIC 208/230-1-60

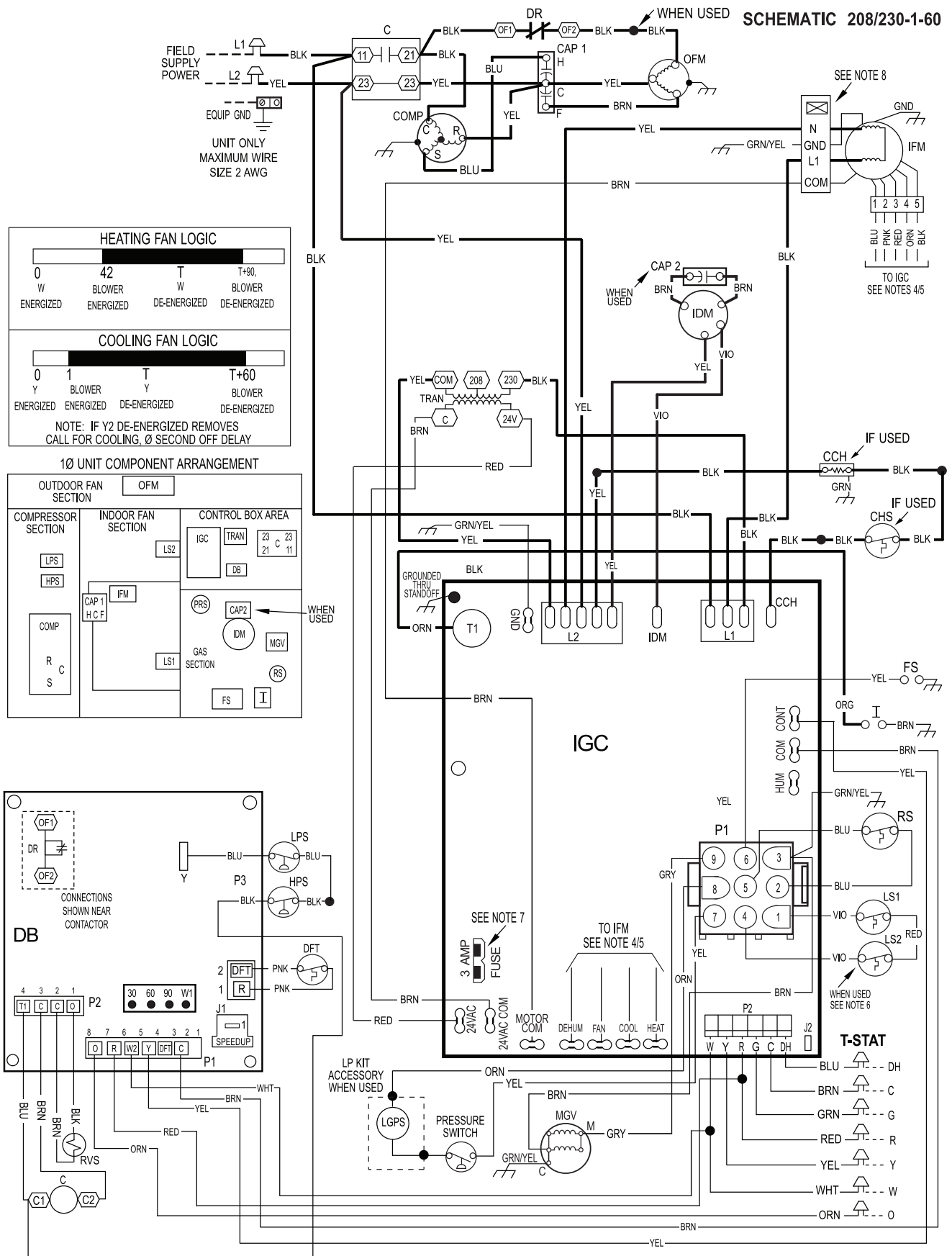

Fig. 15 - 208/230-1-60 Connection Wiring Diagram

A150506

PDD4. PDS4

LADDER WIRING DIAGRAM

DANGER: ELECTRICAL SHOCK HAZARD DISCONNECT POWER BEFORE SERVICING

LEGEND

△	FIELD SPLICE	DFT	DEFROST TEMPERATURE SWITCH
○	TERMINAL (MARKED)	DR	DEFROST RELAY (SEE DB)
○	TERMINAL (UNMARKED)	EQUIP	EQUIPMENT
●	SPLICE	FS	FLAME SENSOR
○	SPLICE (MARKED)	GND	GROUND
—	FACTORY HI VOLTAGE	HPS	HIGH PRESSURE SWITCH
---	FIELD CONTROL WIRING	IGN	IGNITOR
---	FIELD POWER WIRING	IDM	INDUCED DRAFT MOTOR
---	ACCESSORY OR OPTIONAL WIRING	IDR	INDUCER RELAY
---	FACTORY HI VOLTAGE WIRING	IFM	INDOOR FAN MOTOR
---	FIELD CONTROL WIRING	IGC	INTERGRATED GAS UNIT CONTROLLER
---	FIELD POWER WIRING	LGPS	LOW GAS PRESSURE SWITCH (WHEN USED)
---	ACCESSORY OR OPTIONAL WIRING	LPS	LOW PRESSURE SWITCH
---	FACTORY HI VOLTAGE WIRING	LS1	PRIMARY LIMIT SWITCH
C	CONTACTOR	LS2	SECONDARY LIMIT SWITCH
CAP1	CAPACITOR, COMP	MGV	MAIN GAS VALVE
CAP2	CAPACITOR, INDUCER	OFM	OUTDOOR FAN MOTOR
CCH	CRANKCASE HEATER	OT	QUADRUPLE TERMINAL
COMP	COMPRESSOR MOTOR	RS	ROLLOUT SWITCH
DB	DEFROST BOARD	TRAN	TRANSFORMER
		T-STAT	THERMOSTAT

DEFROST TIMING SELECTION

FIELD SELECTABLE OPTIONS FOR TIME PERIOD BETWEEN DEFROST CYCLES (MINUTES). FACTORY DEFROST SETTING IS 60 MIN.

SPEED UP JUMPERED TEST PINS (USE METAL OBJECT) FIELD SPEED-UP CYCLE

1. DFT MUST BE CLOSED TO INITIATE DEFROST CYCLE. IF NECESSARY, REMOVE DFT CONNECTION BEFORE PLACING JUMPER ACROSS DFT PINS.
 2. AT THE SAME TIME DFT CLOSED, JUMPER "SPEED UP" PINS WITH SMALL SCREW DRIVER UNTIL DEFROST IS INITIATED. THEN REMOVE SCREW DRIVER.
 3. SHORTED "SPEED UP" PINS WILL SPEED UP TIMER BY A FACTOR OF 256.

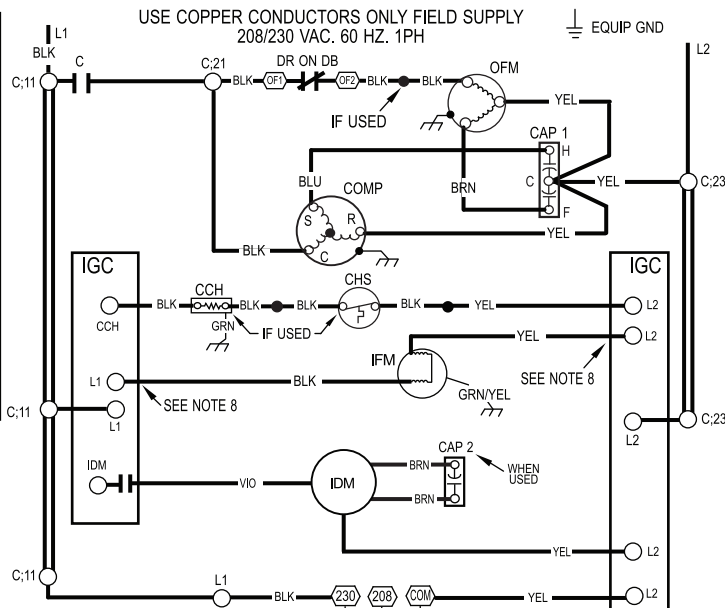

T-STAT

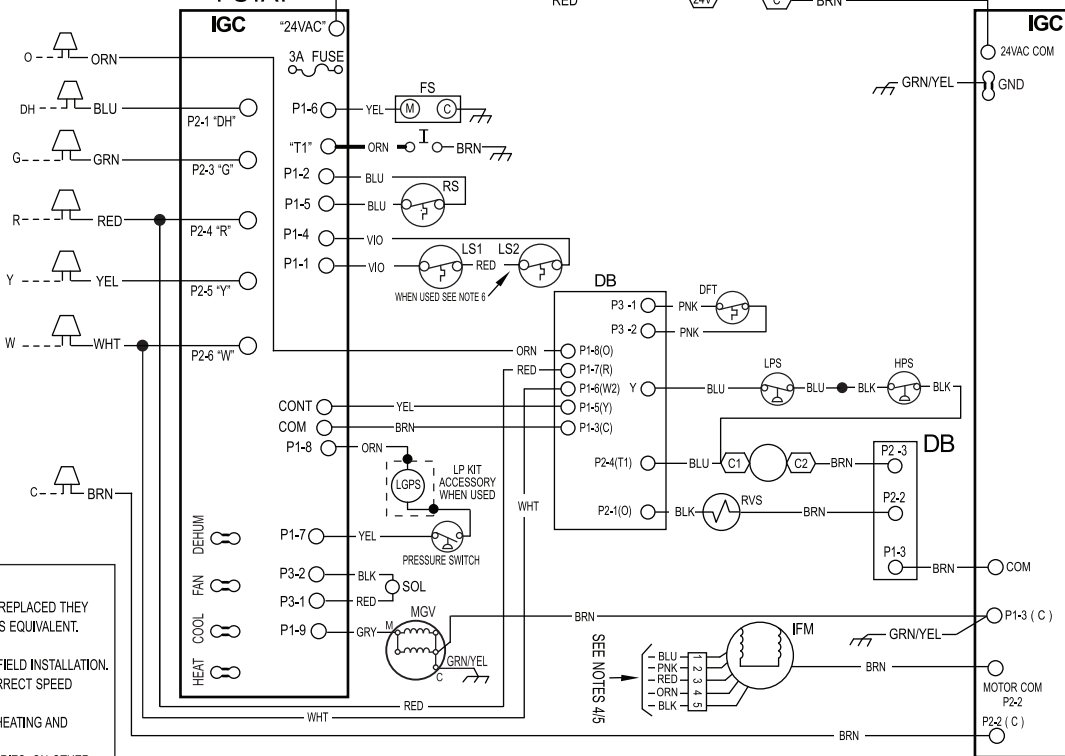

- NOTES:**
- IF ANY OF THE ORIGINAL WIRES FURNISHED ARE REPLACED THEY MUST BE REPLACED WITH THE SAME WIRE OR ITS EQUIVALENT.
 - SEE PRE-SALE LITERATURE FOR THERMOSTATS.
 - USE 75 DEGREES C COPPER CONDUCTORS FOR FIELD INSTALLATION.
 - REFER TO INSTALLATION INSTRUCTIONS FOR CORRECT SPEED SELECTION FOR IFM.
 - SEE INSTALLATION INSTRUCTIONS FOR PROPER HEATING AND COOLING CONNECTIONS FOR YOUR UNIT.
 - ON SOME MODELS LS1 AND LS2 ARE WIRED IN SERIES. ON OTHER MODELS ONLY LS1 IS USED.
 - THIS FUSE IS MANUFACTURED BY LITTLE FUSE, P/N 287003.
 - DO NOT DISCONNECT PLUG UNDER LOAD.
 - N.E.C. CLASS 2, 24V.



48VT500138 REV. -

A150516

Fig. 15 Cont. - 208/230-1-60 Ladder Wiring Diagram

PDD4. PDS4

CONNECTION WIRING DIAGRAM

DANGER: ELECTRICAL SHOCK HAZARD DISCONNECT POWER BEFORE SERVICING

SCHEMATIC
208/230-3-60

NOTES:

- IF ANY OF THE ORIGINAL WIRES FURNISHED ARE REPLACED, THEY MUST BE REPLACED WITH THE SAME WIRE OR ITS EQUIVALENT.
- SEE PRE-SALE LITERATURE FOR THERMOSTATS.
- USE 75 DEG. COPPER CONDUCTORS FOR FIELD INSTALLATION.
- SEE INSTALLATION INSTRUCTIONS FOR PROPER HEATING AND COOLING CONNECTIONS FOR YOUR UNIT. INDOOR FAN MOTOR PLUGS - "DO NOT DISCONNECT UNDER LOAD"
- THIS FUSE IS MANUFACTURED BY LITTEL FUSE, P/N 287003.
- THIS FUSE IS MANUFACTURED BY LITTEL FUSE, P/N 287005.
- INDUCER CAPACITOR AND WIRING ON CERTAIN MODELS ONLY. IF CAP2 IS PRESENT, YELLOW WIRES FROM IGC AND IDM CONNECT ON SAME SIDE OF CAP2.
- REMOVE YELLOW SPlice WIRE WHEN ECONOMIZER AND ECONOMIZER RELAYS ARE USED AND CONNECT TO RELAY R1 AS SHOWN.
- WHEN ECONOMIZER AND ECONOMIZER RELAYS ARE USED, CONNECT THE YELLOW AND BLACK WIRES TO RELAY R AS SHOWN. RELAY KIT REQUIRED WITH ECONOMIZER AND HEAT PUMP/DUAL FUEL UNITS.
- WHEN ECONOMIZER AND ECONOMIZER RELAYS ARE USED, INSTALL WIRES AS SHOWN ONTO THE COILS OF RELAY R AND RELAY R1.
- DEHUMIDIFICATION FEATURE CANNOT BE USED WHEN ECONOMIZER IS INSTALLED.
- N.E.C. CLASS 2 24 V

LEGEND

- | | | | |
|---|------------------------------|--------|-------------------------------------|
| ○ | FIELD SPlice | ECON | ECONOMIZER |
| ○ | TERMINAL (MARKED) | EQUIP | EQUIPMENT |
| ○ | TERMINAL (UNMARKED) | GND | GROUND |
| ○ | SPlice (IF USED) | HPS | HIGH PRESSURE SWITCH |
| ○ | SPlice (MARKED) | I | IGNITOR |
| ○ | FACTORY WIRING | IGC | INTEGRATED GAS UNIT CONTROLLER |
| ○ | FIELD CONTROL WIRING | IFB | INDOOR FAN BOARD |
| ○ | FIELD POWER WIRING | IDM | INDUCED DRAFT MOTOR |
| ○ | ACCESSORY OR OPTIONAL WIRING | IFM | INDOOR FAN MOTOR |
| ○ | | LGPS | LOW GAS PRESSURE SWITCH (WHEN USED) |
| ○ | | LPS | LOW PRESSURE SWITCH |
| ○ | | LS1 | PRIMARY LIMIT SWITCH |
| ○ | | LS2 | SECONDARY LIMIT SWITCH |
| ○ | | MGV | MAIN GAS VALVE |
| ○ | | OMV | OUTDOOR FAN MOTOR |
| ○ | | PRS | PRESSURE SWITCH |
| ○ | | RS | ROLLOUT SWITCH |
| ○ | | RVS | REVERSING VALVE |
| ○ | | SAT | SUPPLY AIR TEMPERATURE |
| ○ | | TRAN | TRANSFORMER |
| ○ | | T-STAT | THERMOSTAT |
| ○ | | R | ECON RELAY |
| ○ | | R1 | ECON RELAY |

- | | |
|-------|------------------------------|
| C | CONTACTOR |
| CAP 1 | CAPACITOR, COMP |
| CAP 2 | CAPACITOR, INDUCER |
| CCH | CRANK CASE HEATER |
| COMP | COMPRESSOR MOTOR |
| CR | COMBUSTION RELAY |
| DB | DEFROST BOARD |
| DFT | DEFROST TEMPERATURE SWITCH |
| DH | DEHUMIDIFICATION MODE SWITCH |
| DR | DEFROST BOARD RELAY |

- COLOR CODE
- | | |
|----|--------|
| BK | BLACK |
| BL | BLUE |
| BR | BROWN |
| GY | GRAY |
| GR | GREEN |
| OR | ORANGE |
| PK | PINK |
| RD | RED |
| VT | VIOLET |
| WH | WHITE |
| YL | YELLOW |

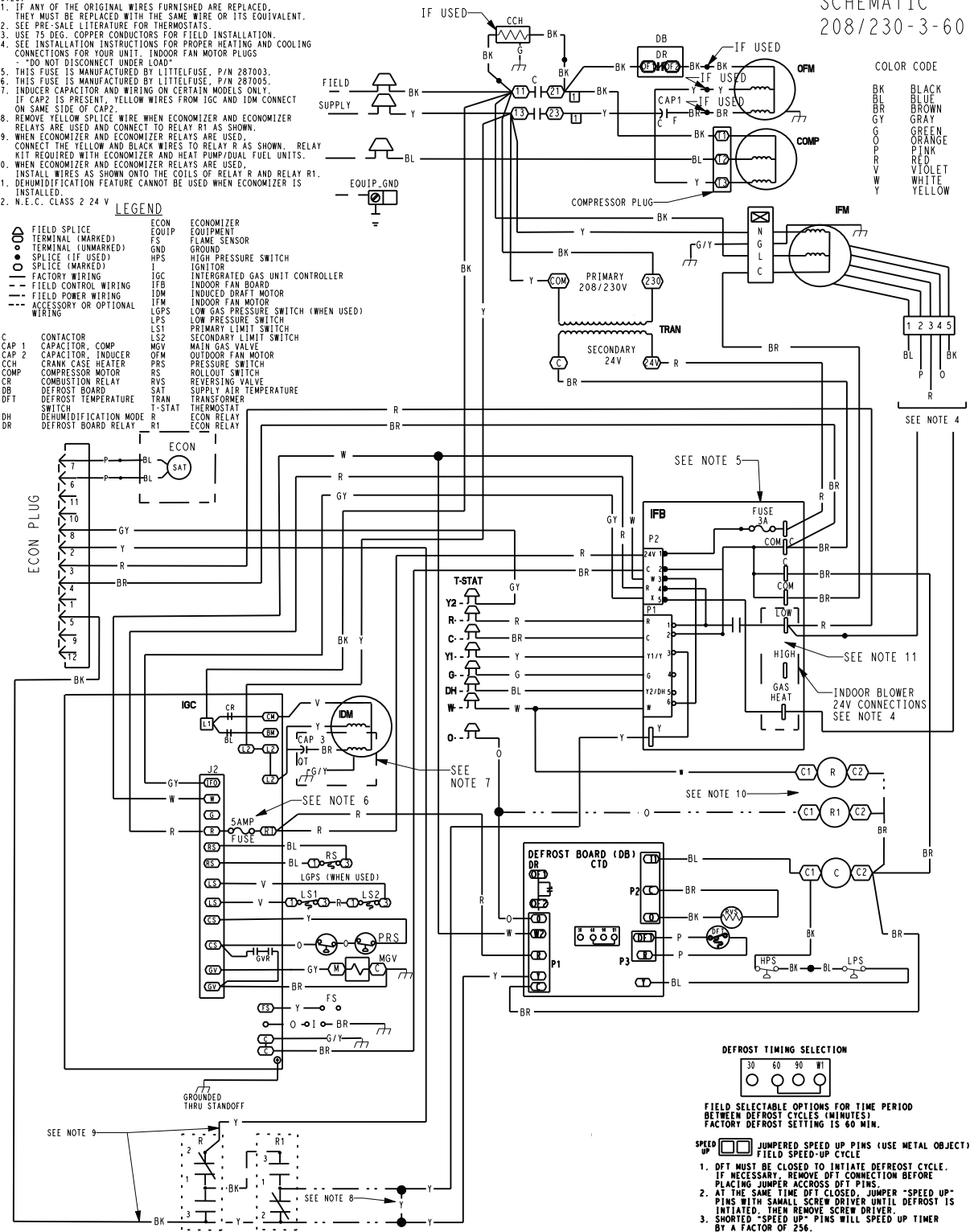

Fig. 16 - 208/230-3-60 Connection Wiring Diagram

A150597

PDD4. PDS4

LADDER WIRING DIAGRAM

DANGER: ELECTRICAL SHOCK HAZARD DISCONNECT POWER BEFORE SERVICING

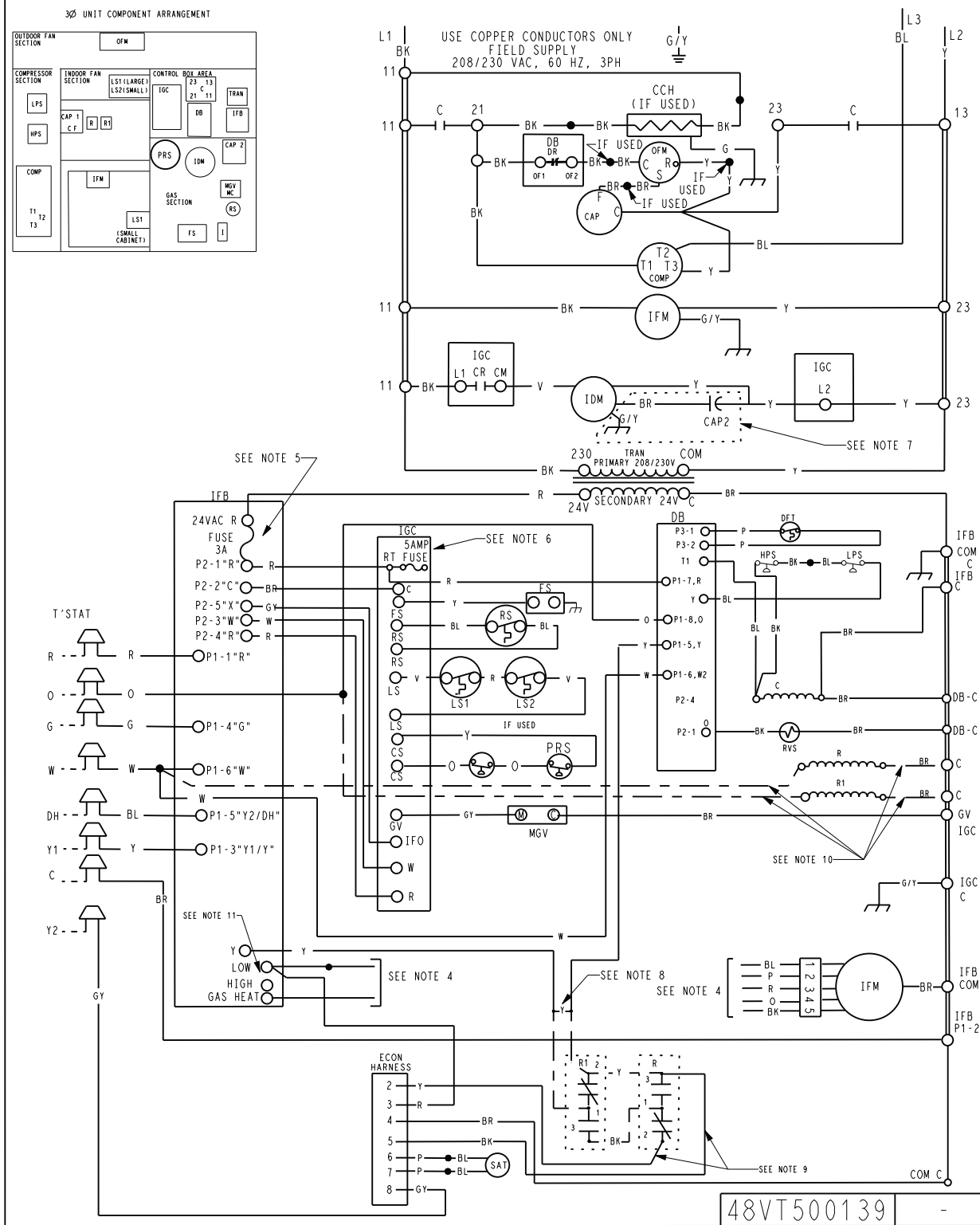

Fig. 16 Cont. - 208/230-3-60 Ladder Wiring Diagram

A150517

PDD4. PDS4

MAINTENANCE

To ensure continuing high performance and to minimize the possibility of premature equipment failure, periodic maintenance must be performed on this equipment. This combination heating/cooling unit should be inspected at least once each year by a qualified service person. To troubleshoot cooling or heating of units, refer to Tables 13, 14, and 15.

NOTE: Consult your local dealer about the availability of a maintenance contract.

⚠ WARNING

PERSONAL INJURY AND UNIT DAMAGE HAZARD

Failure to follow this warning could result in personal injury or death and unit component damage.

The ability to properly perform maintenance on this equipment requires certain expertise, mechanical skills, tools and equipment. If you do not possess these, do not attempt to perform any maintenance on this equipment, other than those procedures recommended in the Owner's Manual.

⚠ WARNING

ELECTRICAL SHOCK HAZARD

Failure to follow these warnings could result in personal injury or death:

1. Turn off electrical power to the unit and install a lockout tag before performing any maintenance or service on this unit.
2. Use extreme caution when removing panels and parts.
3. Never place anything combustible either on or in contact with the unit.
4. Should overheating occur or the gas supply fail to shut off, turn off external main manual gas valve to the unit. Then shut off electrical supply.

⚠ CAUTION

UNIT OPERATION HAZARD

Failure to follow this caution may result in improper operation.

Errors made when reconnecting wires may cause improper and dangerous operation. Label all wires prior to disconnecting when servicing.

The minimum maintenance requirements for this equipment are as follows:

1. Inspect air filter(s) each month. Clean or replace when necessary. Certain geographical locations may require more frequent inspections.
2. Inspect indoor coil, outdoor coil, drain pan, and condensate drain each cooling season for cleanliness. Clean when necessary.
3. Inspect blower motor and wheel for cleanliness at the beginning of each heating and cooling season. Clean when necessary. For first heating and cooling season, inspect blower wheel bi-monthly to determine proper cleaning frequency.
4. Check electrical connections for tightness and controls for proper operation each heating and cooling season. Service when necessary. Ensure electrical wiring is not in contact with refrigerant tubing or sharp metal edges.

5. Check and inspect heating section before each heating season. Clean and adjust when necessary.

6. Check flue hood and remove any obstructions, if necessary.

Air Filter

IMPORTANT: Never operate the unit without a suitable air filter in the return-air duct system. Always replace the filter with the same dimensional size and type as originally installed. (See Table 1 for recommended filter sizes.)

Inspect air filter(s) at least once each month and replace (throwaway-type) or clean (cleanable-type) at least twice during each heating and cooling season or whenever the filter(s) becomes clogged with dust and/or lint.

Indoor Blower and Motor

NOTE: All motors are prelubricated. Do not attempt to lubricate these motors.

For longer life, operating economy, and continuing efficiency, clean accumulated dirt and grease from the blower wheel and motor annually.

⚠ WARNING

ELECTRICAL SHOCK HAZARD

Failure to follow this warning could result in personal injury or death.

Disconnect and install a lockout tag on electrical power to the unit before cleaning the blower motor and wheel.

Cleaning the Blower Motor and Wheel

1. Remove and disassemble blower assembly as follows:
 - a. Remove blower access panel (see Fig. 19).
 - b. Disconnect 5 pin plug and 4 pin plug from indoor blower motor. Remove capacitor if required.
 - c. On all units, remove blower assembly from unit. Remove screws securing blower to blower partition and slide assembly out. Be careful not to tear insulation in blower compartment.
 - d. Ensure proper reassembly by marking blower wheel and motor in relation to blower housing before disassembly.
 - e. Loosen setscrew(s) that secures wheel to motor shaft. Remove screws that secure motor mount brackets to housing, and slide motor and motor mount out of housing.
2. Remove and clean blower wheel as follows:
 - a. Ensure proper reassembly by marking wheel orientation.
 - b. Lift wheel from housing. When handling and/or cleaning blower wheel, be sure not to disturb balance weights (clips) on blower wheel vanes.
 - c. Remove caked-on dirt from wheel and housing with a brush. Remove lint and/or dirt accumulations from wheel and housing with vacuum cleaner, using soft brush attachment. Remove grease and oil with mild solvent.
 - d. Reassemble wheel into housing.
 - e. Reassemble motor into housing. Be sure setscrews are tightened on motor shaft flats and not on round part of shaft. Reinstall blower into unit. Reinstall capacitor.
 - f. Connect 5 pin plug and 4 pin plug to indoor blower motor.
 - g. Reinstall blower access panel (see Fig. 19).
3. Restore electrical power to unit. Start unit and check for proper blower rotation and motor speeds during heating and cooling cycles.

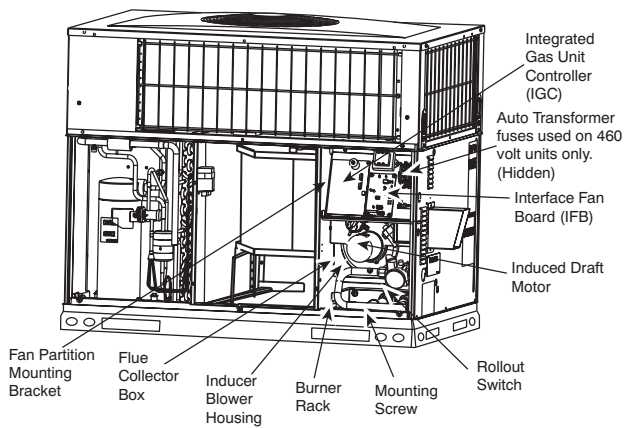

A09193

Fig. 18 - Blower Housing and Flue Collector Box

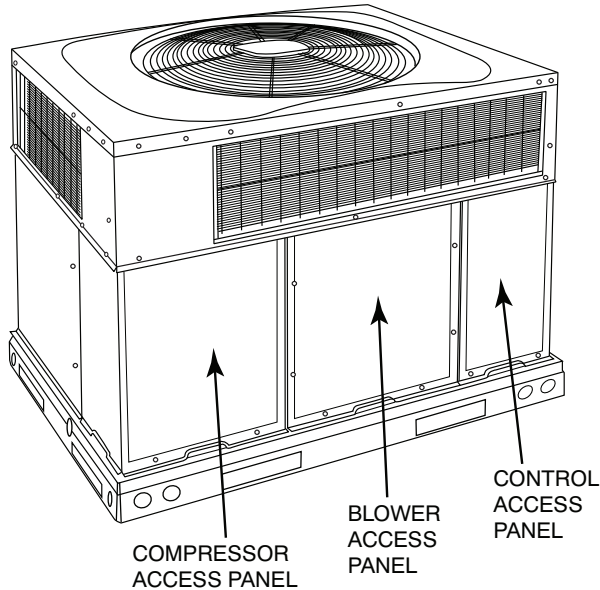

A09207

Fig. 19 - Unit Access Panels

Induced Draft (combustion air) Blower Assembly

The induced-draft blower assembly consists of the inducer motor, the blower housing, and the induced-draft blower wheel.

Clean periodically to assure proper airflow and heating efficiency. Inspect blower wheel every fall and periodically during the heating season. For the first heating season, inspect blower wheel bimonthly to determine proper cleaning frequency.

To inspect blower wheel, remove draft hood assembly. Shine a flashlight into opening to inspect wheel. If cleaning is required, remove induced-draft blower assembly as follows:

1. Remove control access panel (See Fig. 19).
2. Remove the 5 screws that attach induced-draft blower assembly to the flue collector box cover.
3. Slide the assembly out of the unit. (See Fig. 20). Clean the blower wheel. If additional cleaning is required, continue with Steps 4 and 5.
4. To remove blower wheel, remove 2 setscrews.
5. To remove inducer motor, remove screws that hold the inducer motor to the blower housing.
6. To reinstall, reverse the procedure outlined above.

Flue Gas Passageways

To inspect the flue collector box and upper areas of the heat exchanger:

1. Remove the induced draft blower assembly according to directions in the Induced Draft Blower Assembly section.
2. Remove the 11 screws holding the flue collector box cover

(See Fig. 18) to the heat exchanger assembly. Inspect the heat exchangers.

3. Clean all surfaces, as required, using a wire brush.

Limit Switch

Remove blower access panel (see Fig. 19). Limit switch is located on the fan partition.

Burner Ignition

Unit is equipped with a direct spark ignition 100 percent lockout system. Ignition module (IGC) is located in the control box (See Fig. 18). Module contains a self-diagnostic LED. During servicing, refer to label diagram or Table 5 in these instructions for LED interpretation.

If lockout occurs, unit may be reset by either momentarily interrupting power supply to unit or by turning selector switch to OFF position at the thermostat.

Main Burners

At the beginning of each heating season, inspect for deterioration or blockage due to corrosion or other causes. Observe the main burner flames and adjust, if necessary.

Removal of Gas Train

To remove the gas train for servicing:

1. Shut off main gas valve.
2. Shut off power to unit and install lockout tag.
3. Remove control access panel (See Fig. 19).
4. Disconnect gas piping at unit gas valve.
5. Remove fan partition mounting bracket (2 screws located on the left side of control compartment on the fan partition panel). Slide bracket forward, bottom first to remove. (See Fig. 18).
6. Remove wires connected to gas valve. Mark each wire.
7. Remove ignitor and sensor wires at the ignitor module.
8. Remove the mounting screw that attaches the burner rack to the unit base (See Fig. 18).
9. Slide the burner rack out of the unit (See Fig. 18 and 21).
10. To reinstall, reverse the procedure outlined above.
11. Check all connections for leaks.

⚠ WARNING

FIRE, EXPLOSION HAZARD

Failure to follow this warning could result in personal injury, death or property damage.

Do not purge gas supply into the combustion chamber. Do not use a match or other open flame to check for gas leaks. Use a commercially available soap solution made specifically for the detection of leaks to check all connections. A fire or explosion may result causing property damage, personal injury or loss of life.

Outdoor Coil, Indoor Coil, and Condensate Drain Pan

Inspect the outdoor coil, indoor coil, and condensate drain pan at least once each year. The coils are easily cleaned when dry; therefore, inspect and clean the coils either before or after each cooling season. Remove all obstructions, including weeds and shrubs, that interfere with the airflow through the condenser coil.

Straighten bent fins with a fin comb. If coated with dirt or lint, clean the coils with a vacuum cleaner, using the soft brush attachment. Be careful not to bend the fins. If coated with oil or grease, clean the coils with a mild detergent-and-water solution. Rinse coils with clear water, using a garden hose. Be careful not to splash water on motors, insulation, wiring, or air filter(s). For best results, spray outdoor coil fins from inside to outside the unit. On units with an outer and inner condenser coil, be sure to clean

between the coils. Be sure to flush all dirt and debris from the unit base.

Inspect the drain pan and condensate drain line when inspecting the coils. Clean the drain pan and condensate drain by removing all foreign matter from the pan. Flush the pan and drain tube with clear water. Do not splash water on the insulation, motor, wiring, or air filter(s). If the drain tube is restricted, clear it with a “plumbers snake” or similar probe device. Ensure that the auxiliary drain port above the drain tube is also clear.

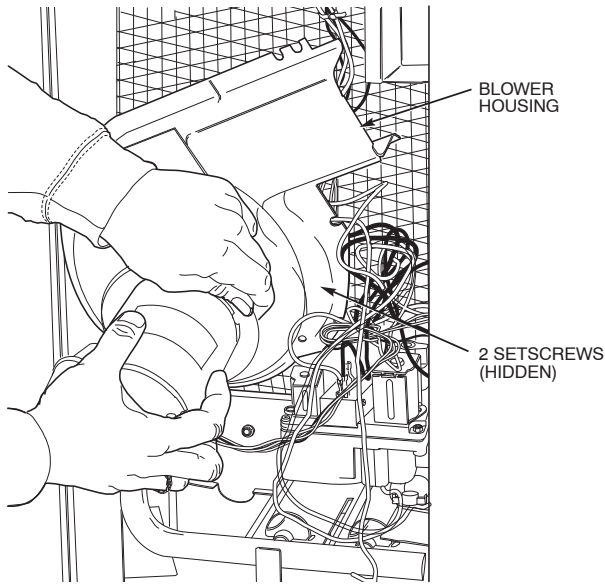

Fig. 20 - Removal of Motor and Blower Wheel

C99085

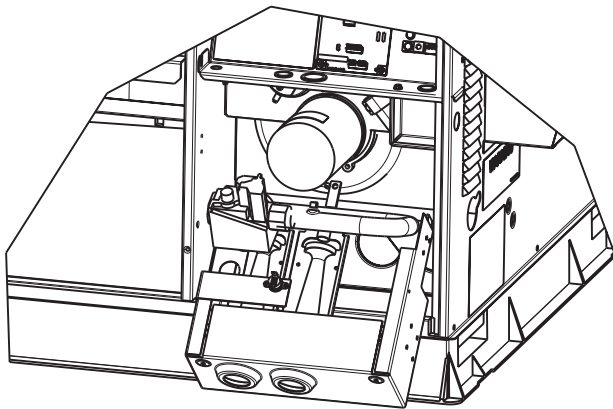

Fig. 21 - Burner Rack Removed

A07680

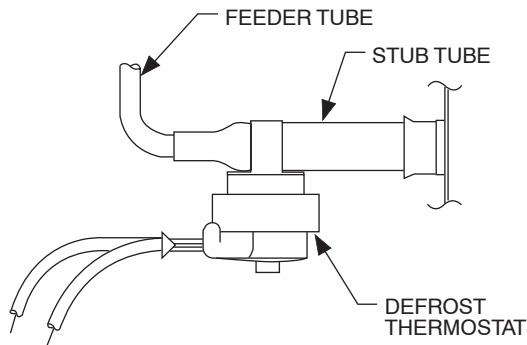

Fig. 22 - Defrost Thermostat Location

C99029

Outdoor Fan



CAUTION

UNIT OPERATION HAZARD

Failure to follow this caution may result in damage to unit components.

Keep the outdoor fan free from all obstructions to ensure proper cooling operation. Never place articles on top of the unit.

1. Remove 6 screws holding outdoor grille and motor to top cover.
2. Turn motor/grille assembly upside down on top cover to expose the fan blade.
3. Inspect the fan blades for cracks or bends.
4. If fan needs to be removed, loosen the setscrew and slide the fan off the motor shaft.
5. When replacing fan blade, position blade back to the same position as before.
6. Ensure that setscrew engages the flat area on the motor shaft when tightening.
7. Replace grille.

Electrical Controls and Wiring

Inspect and check the electrical controls and wiring annually. Be sure to turn off the gas supply, and then the electrical power to the unit.

Remove access panels (see Fig. 19) to locate all the electrical controls and wiring. Check all electrical connections for tightness. Tighten all screw connections. If any discolored or burned connections are noticed, disassemble the connection, clean all the parts, re-strip the wire end and reassemble the connection properly and securely.

After inspecting the electrical controls and wiring, replace the access panels (see Fig. 19). Start the unit, and observe at least one complete heating cycle and one complete cooling cycle to ensure proper operation. If discrepancies are observed in any operating cycle, or if a suspected malfunction has occurred, check each electrical component with the proper electrical instrumentation. Refer to the unit wiring label when making these checkouts.

NOTE: Refer to the heating and/or cooling sequence of operation in this publication as an aid in determining proper control operation.

Refrigerant Circuit

Annually inspect all refrigerant tubing connections.



WARNING

EXPLOSION, PERSONAL INJURY AND ENVIRONMENTAL HAZARD

Failure to follow this warning could result in personal injury, death or property damage.

System under pressure. Relieve pressure and recover all refrigerant before system repair or final unit disposal. Use all service ports and open all flow-control devices, including solenoid valves.

If low cooling performance is suspected, leak-test all refrigerant tubing using an electronic leak-detector, halide torch, or liquid-soap solution. If a refrigerant leak is detected, refer to the Check for Refrigerant Leaks section.

If no refrigerant leaks are found and low cooling performance is suspected, refer to the Checking and Adjusting Refrigerant Charge section.

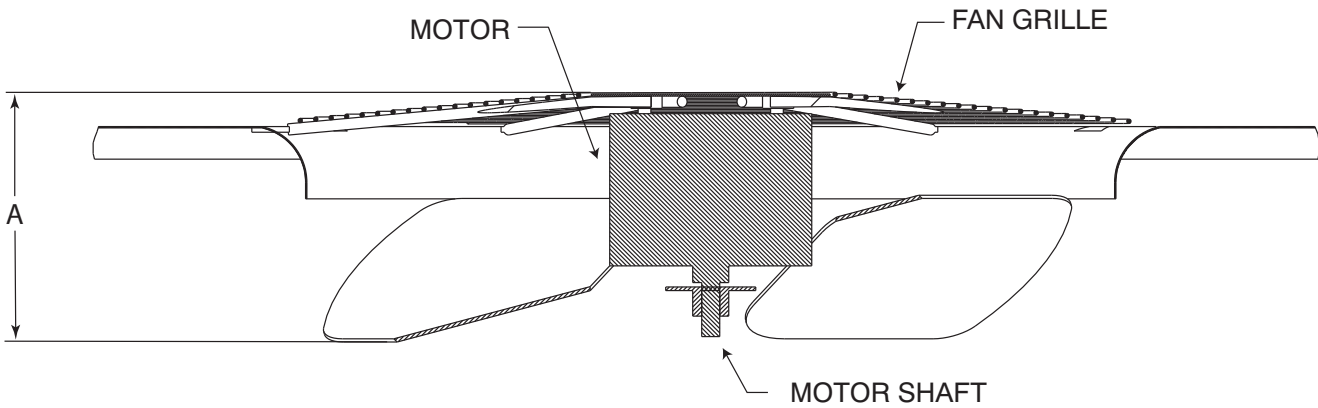

A08505

MAX DISTANCE BETWEEN TOP OF FAN GRILLE AND BOTTOM OF FAN BLADE

SIZE	"A"	
	IN.	MM
24	9.0	228
30	7.1	180
36	7.6	193
42	7.6	193
48	7.6	193
60	7.6	193

Fig. 23 - Fan Blade Position

PDD4. PDS4

Gas Input

The gas input does not require checking unless improper heating performance is suspected. If a problem exists, refer to the Start-Up section.

Indoor Airflow

The heating and/or cooling airflow does not require checking unless improper performance is suspected. If a problem exists, be sure that all supply- and return-air grilles are open and free from obstructions, and that the air filter is clean. When necessary, refer to the Indoor Airflow and Airflow Adjustments section to check the system airflow.

Check Defrost Thermostat

The defrost thermostat is usually located on the lowest liquid leaving circuit of the left condenser coil (see Fig. 22). The thermostat closes at 32°F (0°C) and opens at 65°F (18°C).

R-410A Items

Metering Device (Thermostatic Expansion Valve & Piston)

This unit uses both a hard shutoff, balance port TXV in the indoor coil and a piston in each side of the outdoor coil. The TXV maintains a constant superheat at the evaporator coil exit (cooling mode) resulting in higher overall system efficiency.

Pressure Switches

Pressure switches are protective devices wired into control circuit (low voltage). They shut off compressor if abnormally high or low pressures are present in the refrigeration circuit. These pressure switches are specifically designed to operate with R-410A systems. R-22 pressure switches must not be used as replacements for the R-410A system.

Loss of Charge Switch

This switch is located on the liquid line and protects against low suction pressures caused by such events as loss of charge, low airflow across indoor coil, dirty filters, etc. It opens on a pressure drop at about 20 psig. If system pressure is above this, switch should be closed. To check switch:

1. Turn off all power to unit.
2. Disconnect leads on switch.

3. Apply ohm meter leads across switch. You should have continuity on a good switch.

NOTE: Because these switches are attached to refrigeration system under pressure, it is not advisable to remove this device for troubleshooting unless you are reasonably certain that a problem exists. If switch must be removed, remove and recover all system charge so that pressure gauges read 0 psig. Never open system without breaking vacuum with dry nitrogen.

High-Pressure Switch

The high-pressure switch is located in the discharge line and protects against excessive condenser coil pressure. It opens at 650 psig.

High pressure may be caused by a dirty outdoor coil, failed fan motor, or outdoor air recirculation. To check switch:

1. Turn off all power to unit.
2. Disconnect leads on switch.
3. Apply ohm meter leads across switch. You should have continuity on a good switch.

Copeland Scroll Compressor (R-410A Refrigerant)

The compressor used in this product is specifically designed to operate with R-410A refrigerant and cannot be interchanged.

The compressor is an electrical (as well as mechanical) device. Exercise extreme caution when working near compressors. Power should be shut off, if possible, for most troubleshooting techniques. Refrigerants present additional safety hazards.



WARNING

EXPLOSION HAZARD

Failure to follow this warning could result in personal injury or death and/or property damage.

Wear safety glasses and gloves when handling refrigerants. Keep torches and other ignition sources away from refrigerants and oils.



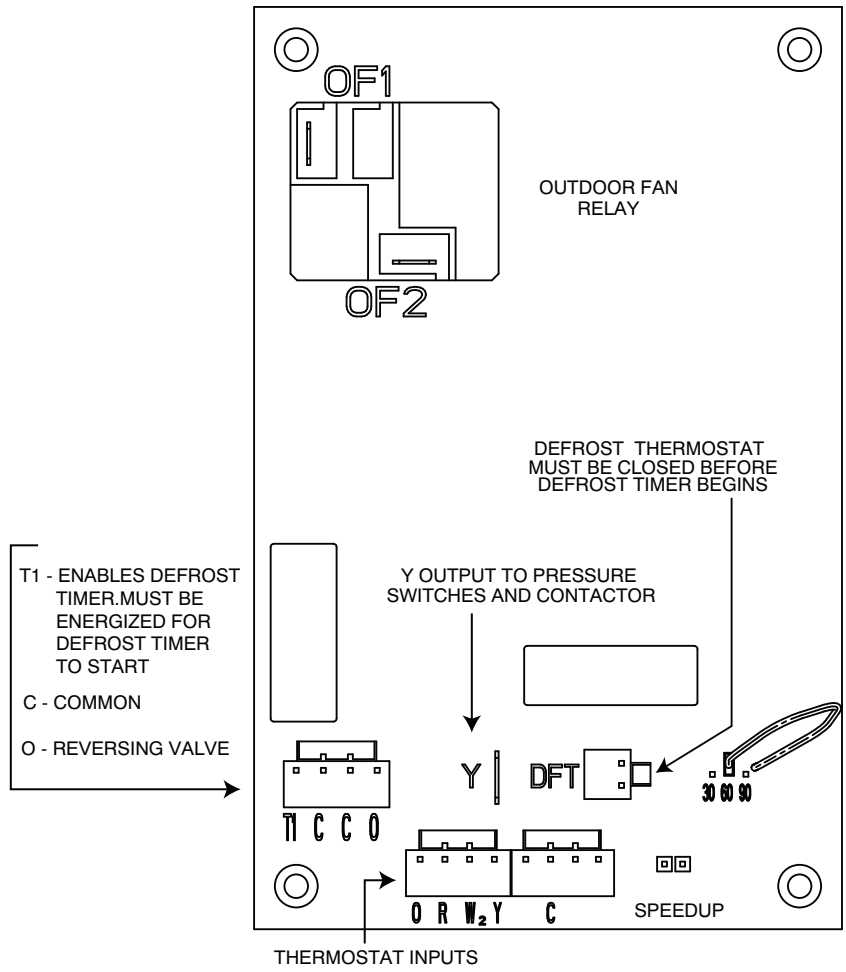

Fig. 24 - Defrost Control

A150622

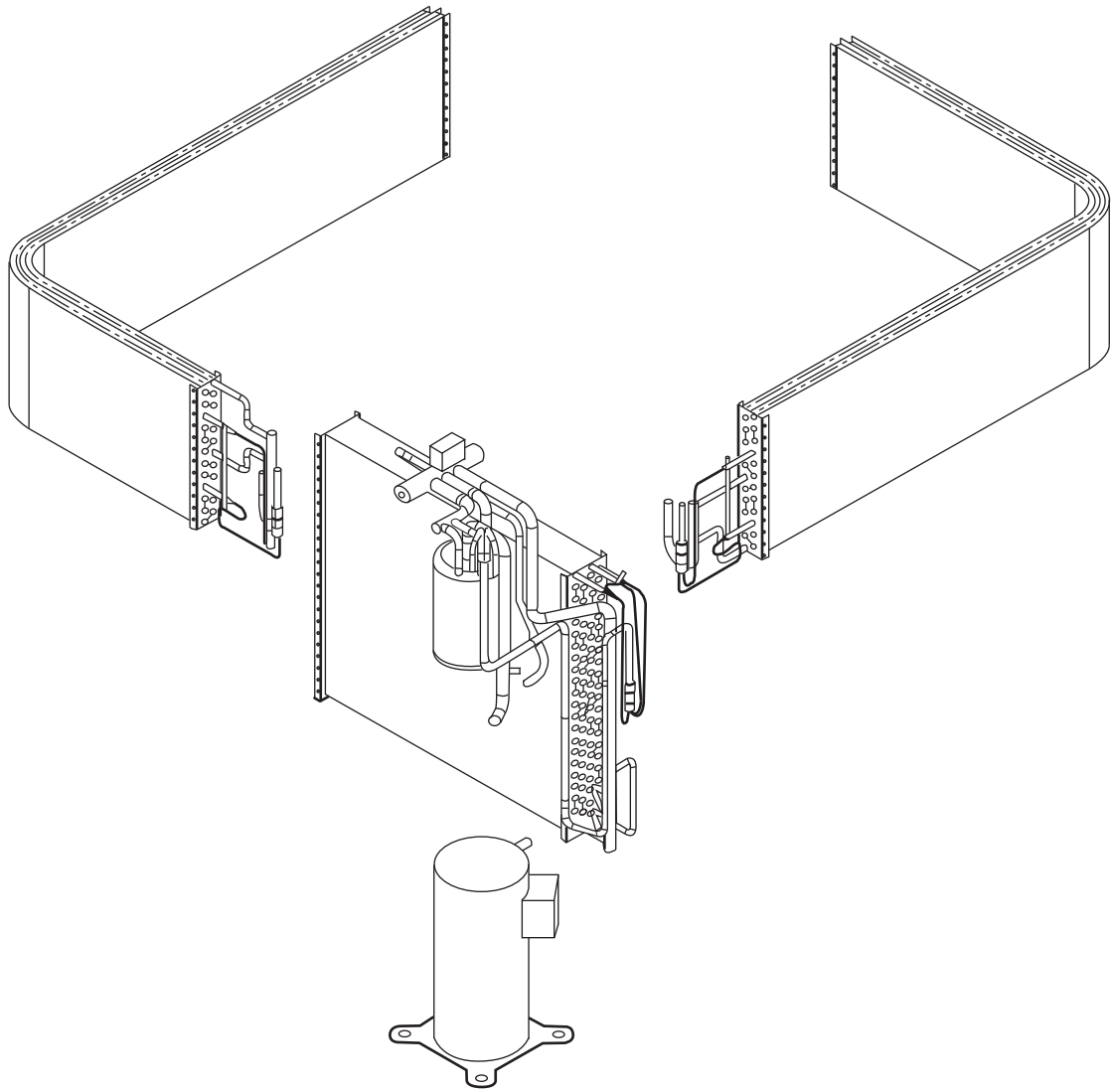

Fig. 25 - Refrigerant Circuit

C99097

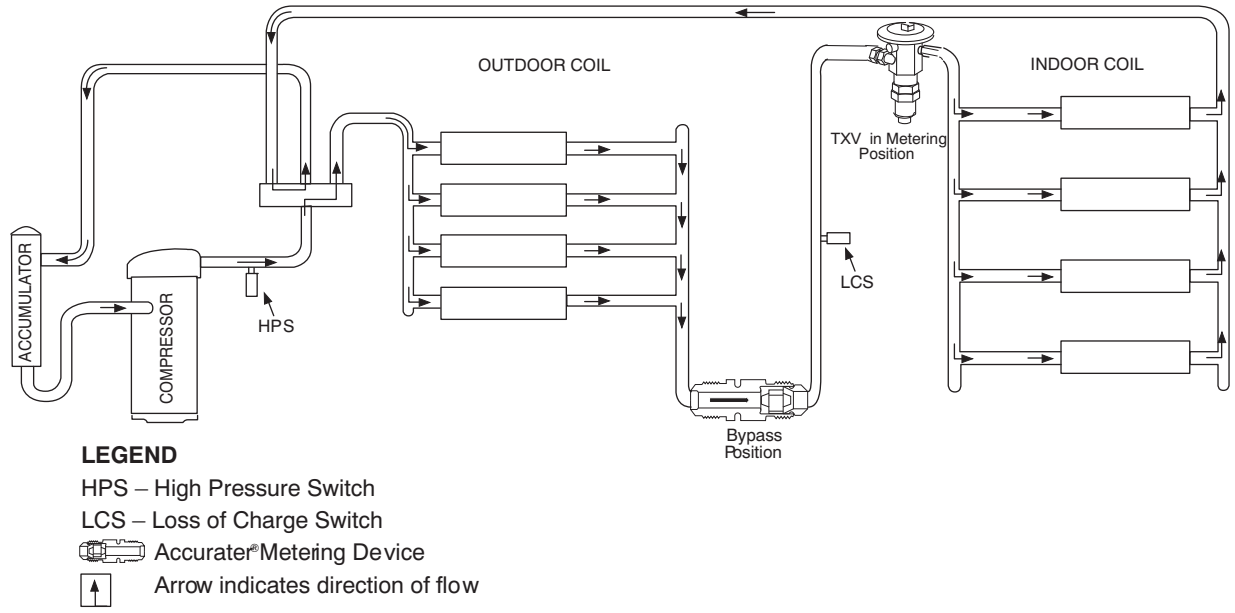
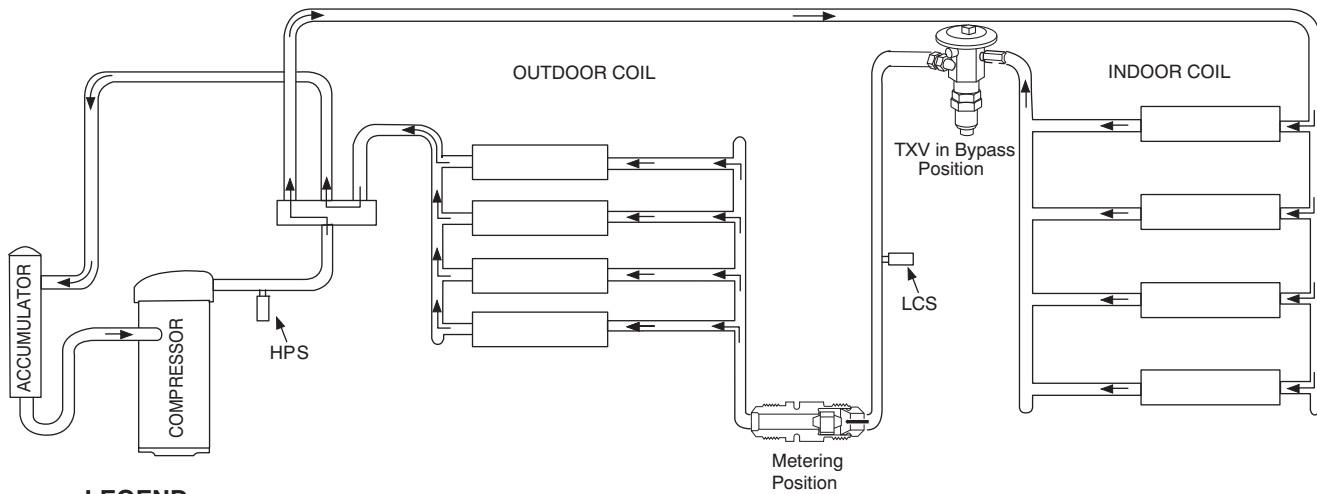

Fig. 26 - Typical Heat Pump Operation, Cooling Mode

C03011



LEGEND



- HPS – High Pressure Switch
- LCS – Loss of Charge Switch
-  Accurater® Metering Device
-  Arrow indicates direction of flow

Fig. 27 - Typical Heat Pump Operation, Heating Mode

C03012

The scroll compressor pumps refrigerant throughout the system by the interaction of a stationary and an orbiting scroll. The scroll compressor has no dynamic suction or discharge valves, and it is more tolerant of stresses caused by debris, liquid slugging, and flooded starts. The compressor is equipped with an internal pressure relief port. The pressure relief port is a safety device, designed to protect against extreme high pressure. The relief port has an operating range between 550 and 625 psig differential pressure.

⚠ WARNING

UNIT OPERATION AND SAFETY HAZARD

Failure to follow this warning could result in personal injury or equipment damage.

This system uses R-410A refrigerant which has higher operating pressures than R-22 and other refrigerants. No other refrigerant may be used in this system. Gauge set, hoses, and recovery system must be designed to handle R-410A. If you are unsure, consult the equipment manufacturer.

Refrigerant System

This information covers the refrigerant system including the compressor oil needed, servicing systems on roofs containing synthetic materials, the filter drier and refrigerant charging.

Compressor Oil

If additional oil is needed use Uniqema RL32-3MAF. If this oil is not available, use Copeland Ultra 32CC or Mobil Artic EAL22CC. This oil is extremely hygroscopic, meaning it absorbs water readily. POE oils can absorb 15 times as much water as other oils designed for HCFC and CFC refrigerants. Take all necessary precautions to avoid exposure of the oil to the atmosphere.

Servicing Systems on Roofs and with Synthetic materials

POE (polyolester) compressor lubricants are known to cause long term damage to some synthetic roofing materials.

Exposure, even if immediately cleaned up, may cause embrittlement (leading to cracking) to occur in one year or more. When performing any service that may risk exposure of compressor oil to the roof, take appropriate precautions to protect roofing. Procedures which risk oil leakage include, but are not

limited to, compressor replacement, repairing refrigerant leaks, replacing refrigerant components such as filter drier, pressure switch, metering device, coil, accumulator, or reversing valve.

Synthetic Roof Precautionary Procedure

1. Cover extended roof working area with an impermeable polyethylene (plastic) drip cloth or tarp. Cover an approximate 10x10 ft (3x3 m) area.
2. Cover area in front of the unit service panel with a terry cloth shop towel to absorb lubricant spills and prevent run-offs, and protect drop cloth from tears caused by tools or components.
3. Place terry cloth shop towel inside unit immediately under component(s) to be serviced and prevent lubricant run-offs through the louvered openings in the unit base.
4. Perform required service.
5. Remove and dispose of any oil contaminated material per local codes.

Liquid Line Filter Drier

This filter drier is specifically designed to operate with R-410A. Use only factory-authorized components. Filter drier must be replaced whenever the refrigerant system is opened. When removing a filter drier, use a tubing cutter to cut the drier from the system. Do not unsweat a filter drier from the system. Heat from unsweating will release moisture and contaminants from drier into system.

R-410A Refrigerant Charging

Refer to unit information plate and charging chart. Some R-410A refrigerant cylinders contain a dip tube to allow liquid refrigerant to flow from cylinder in upright position. For cylinders equipped with a dip tube, charge R-410A units with cylinder in upright position and a commercial metering device in manifold hose. Charge refrigerant into suction-line.

Check Defrost Thermostat

The defrost thermostat is usually located on the lowest liquid leaving circuit of the left condenser coil (see Fig. 28). The thermostat closes at 32°F (0°C) and opens at 65°F (18°C).

The defrost thermostat signals heat pump that conditions are right for defrost or that conditions have changed to terminate defrost. It is a thermally actuated switch clamped to outdoor coil to sense its

temperature. Normal temperature range is closed at $32^{\circ} \pm 3^{\circ}\text{F}$ ($0 \pm 1.7^{\circ}\text{C}$) and open at $65^{\circ} \pm 5^{\circ}\text{F}$ ($18 \pm 2.8^{\circ}\text{C}$).

NOTE: The defrost thermostat must be located on the liquid side of the outdoor coil on the bottom circuit and as close to the coil as possible. The factor location is on the left/back coil.

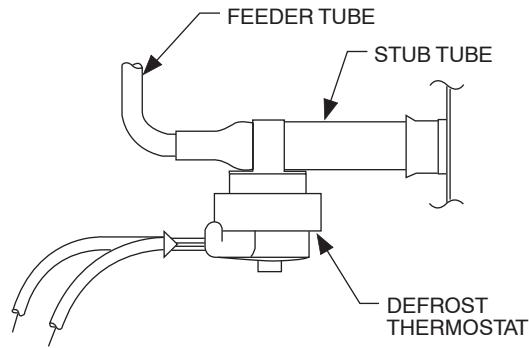

Fig. 28 - Defrost Thermostat

C99029

TROUBLESHOOTING

Use the Troubleshooting Guides (See Tables 13-15) if problems occur with these units.

START-UP CHECKLIST

Use Start-Up checklist to ensure proper start-up procedures are followed.

R-410A QUICK REFERENCE GUIDE

- R-410A refrigerant operates at 50-70 percent higher pressures than R-22. Be sure that servicing equipment and replacement components are designed to operate with R-410A
- R-410A refrigerant cylinders are rose colored.
- Recovery cylinder service pressure rating must be 400 psig, DOT 4BA400 or DOT BW400.
- R-410A systems should be charged with liquid refrigerant. Use a commercial type metering device in the manifold hose when charging into suction line with compressor operating
- Manifold sets should be minimum 700 psig high side and 180 psig low side with 550 psig low-side retard.
- Use hoses with minimum 700 psig service pressure rating.
- Leak detectors should be designed to detect HFC refrigerant.
- R-410A, as with other HFCs, is only compatible with POE oils.
- Vacuum pumps will not remove moisture from oil.
- Do not use liquid-line filter driers with rated working pressures less than 600 psig.
- Do not leave R-410A suction line filter driers in line longer than 72 hrs.
- Do not install a suction-line filter drier in liquid line.
- POE oils absorb moisture rapidly. Do not expose oil to atmosphere.
- POE oils may cause damage to certain plastics and roofing materials.
- Wrap all filter driers and service valves with wet cloth when brazing.
- A factory approved liquid-line filter drier is required on every unit.
- Do NOT use an R-22 TXV.
- Never open system to atmosphere while it is under a vacuum.
- When system must be opened for service, recover refrigerant, evacuate then break vacuum with dry nitrogen and replace filter driers. Evacuate to 500 microns prior to recharging.
- Do not vent R-410A into the atmosphere.
- Observe all **warnings**, **cautions**, and **bold** text.
- All indoor coils must be installed with a hard shutoff R-410A TXV metering device.

Table 13 – Troubleshooting Guide - Cooling or Heat Pump Heating Mode

SYMPTOM	CAUSE	REMEDY	
Compressor and Outdoor fan will not start.	Power Failure	Call power company.	
	Fuse blown or circuit breaker tripped	Replace fuse or reset circuit breaker.	
	Defective thermostat, contactor, transformer, or control relay	Replace component.	
	Insufficient line voltage	Determine cause and correct.	
	Incorrect or faulty wiring	Check wiring diagram and rewire correctly.	
Compressor will not start but Outdoor fan runs.	Thermostat setting too high	Lower thermostat setting below room temperature.	
	Faulty wiring or loose connections in compressor circuit	Check wiring and repair or replace.	
	Compressor motor burned out, seized, or internal overload open	Determine cause Replace compressor.	
	Defective run/start capacitor, overload, start relay	Determine cause and replace.	
Three-phase scroll compressor makes excessive noise, and there may be a low pressure differential.	One leg of 3-phase power dead	Replace fuse or reset circuit breaker. Determine cause.	
	Scroll compressor is rotating in the wrong direction	Correct the direction of rotation by reversing the 3-phase power leads to the unit.	
Compressor cycles (other than normally satisfying thermostat).	Refrigerant overcharge or undercharge	Recover refrigerant, evacuate system, and recharge to capacities shown on nameplate.	
	Defective compressor	Replace and determine cause.	
	Insufficient line voltage	Determine cause and correct.	
	Blocked Outdoor	Determine cause and correct.	
	Defective run/start capacitor, overload or start relay	Determine cause and replace.	
	Defective thermostat	Replace thermostat.	
	Faulty Outdoor – fan motor or capacitor	Replace.	
	Damaged reversing valve	Determine cause and correct	
	Restriction in refrigerant system	Locate restriction and remove.	
	Compressor operates continuously.	Dirty air filter	Replace filter.
Unit undersized for load		Decrease load or increase unit size.	
Thermostat set too low		Reset thermostat.	
Low refrigerant charge		Locate leak, repair, and recharge.	
Mechanical damage in compressor.		Replace compressor.	
Air in system		Recover refrigerant, evacuate system, and recharge.	
Frosted coil with incorrect defrost operation		Check defrost time settings, Reset as necessary Check defrost temperature switch, Replace as necessary	
Outdoor coil dirty or restricted		Clean coil or remove restriction .	
Excessive head pressure.		Dirty air filter	Replace filter.
		Dirty Indoor or Outdoor coil	Clean coil.
	Refrigerant overcharged	Recover excess refrigerant.	
	Air in system	Recover refrigerant, evacuate system, and recharge.	
	Indoor or Outdoor air restricted or air short – cycling	Determine cause and correct.	
Head pressure too low.	Low refrigerant charge	Check for leaks, repair, and recharge.	
	Compressor IPR leaking	Replace compressor.	
	Restriction in liquid tube	Remove restriction.	
Excessive suction pressure.	High heat load	Check for source and eliminate.	
	Compressor IPR leaking	Replace compressor.	
	Refrigerant overcharged	Recover excess refrigerant.	
	Reversing valve hung up or leaking internally	Replace valve	
Suction pressure too low.	Dirty air filter	Replace Filter.	
	Low refrigerant charge	Check for leaks, repair, and recharge.	
	Metering device or low side restricted	Remove source of restriction.	
	Insufficient Indoor airflow	Increase air quantity. Check filter — replace if necessary.	
	Temperature too low in conditioned area	Reset thermostat.	
	Outdoor ambient below 55°F (12.8°C)	Install low-ambient kit.	
	Field – installed filter – drier restricted	Replace.	
	(Heat) Outdoor coil frosted	Move timer on control board to 30 minutes between defrost cycles	
Compressor runs but outdoor fan does not	NC (normally closed) contacts on defrost board open	Check condition of relay on board Replace if necessary	

PDD4. PDS4

Table 14 – Troubleshooting Guide–Heating

SYMPTOM	CAUSE	REMEDY
Burners will not ignite	Water in gas line	Drain. Install drip leg.
	No power to furnace	Check power supply fuses, wiring or circuit breaker.
	No 24-v power supply to control circuit	Check transformer. NOTE: Some transformers have internal over-current protection that requires a cool-down period to reset.
	Mis-wired or loose connections	Check all wiring and wire nut connections
	Misaligned spark electrodes	Check flame ignition and sense electrode positioning. Adjust as necessary.
	No gas at main burners	1. Check gas line for air. Purge as necessary. NOTE: After purging gas line of air, wait at least 5 minutes for any gas to dissipate before attempting to light unit. 2. Check gas valve.
Inadequate heating	Dirty air filter	Clean or replace filter as necessary
	Gas input to furnace too low	Check gas pressure at manifold match with that on unit nameplate
	Unit undersized for application	Replace with proper unit or add additional unit
	Restricted airflow	Clean or replace filter. Remove any restriction.
	Limit switch cycles main burners	Check rotation of blower, temperature rise of unit. Adjust as necessary.
Poor flame characteristics	Incomplete combustion results in: Aldehyde odors, carbon monoxide, sooting flame, floating flame	1. Tighten all screws around burner compartment 2. Cracked heat exchanger. Replace. 3. Unit over-fired. Reduce input (change orifices or adjust gas line or manifold pressure). 4. Check burner alignment. 5. Inspect heat exchanger for blockage. Clean as necessary.

Table 15 – Troubleshooting Guide–LED Status Codes

SYMPTOM	CAUSE	REMEDY
No Power Hardware failure (LED OFF)	Loss of power to control module (IGC)*.	Check 5-amp fuse on IGC*, power to unit, 24-v circuit breaker, and transformer. Units without a 24-v circuit breaker have an internal overload in the 24-v transformer. If the overload trips, allow 10 minutes for automatic reset.
Check fuse, low voltage circuit (LED 1 flash)	Fuse is blown or missing or short circuit in secondary (24VAC) wiring.	Replace fuse if needed. Verify no short circuit in low voltage (24 VAC wiring).
Limit switch faults (LED 2 flashes)	High temperature limit switch is open.	Check the operation of the indoor (evaporator) fan motor. Ensure that the supply-air temperature rise is in accordance with the range on the unit nameplate. Clean or replace filters.
Flame sense fault (LED 3 flashes)	The IGC* sensed flame that should not be present.	Reset unit. If problem persists, replace control board.
4 consecutive limit switch faults (LED 4 flashes)	Inadequate airflow to unit.	Check the operation of the indoor (evaporator) fan motor and that supply-air temperature rise agrees with range on unit nameplate information.
Ignition lockout (LED 5 flashes)	Unit unsuccessfully attempted ignition for 15 minutes.	Check ignitor and flame sensor electrode spacing, gaps, etc. Ensure that flame sense and ignition wires are properly terminated. Verify that unit is obtaining proper amount of gas.
Pressure Switch motor fault (LED 6 flashes)	Open pressure switch.	Verify wiring connections to pressure switch and inducer motor. Verify pressure switch hose is tightly connected to both inducer housing and pressure switch. Verify inducer wheel is properly attached to inducer motor shaft. Verify inducer motor shaft is turning.
Rollout switch fault (LED 7 flashes)	Rollout switch has opened.	Rollout switch will automatically reset, but IGC* will continue to lockout unit. Check gas valve operation. Ensure that induced-draft blower wheel is properly secured to motor shaft. Inspect heat exchanger. Reset unit at unit disconnect.
Internal control fault (LED 8 flashes)	Microprocessor has sensed an error in the software or hardware.	If error code is not cleared by resetting unit power, replace the IGC*.
Temporary 1 hr auto reset (LED 9 flashes)	Electrical interference impeding IGC software	Reset 24-v. to control board or turn thermostat off, then on again. Fault will automatically reset itself in one (1) hour.

IMPORTANT: Refer to Table 14–Troubleshooting Guide–Heating for additional troubleshooting analysis.

LEGEND

IGC—Integrated Gas Unit Controller

LED—Light–Emitting Diode

▲ CAUTION

ELECTROSTATIC DISCHARGE (ESD) PRECAUTIONS PROCEDURE RELIABILITY HAZARD

Failure to follow this caution may result in unit component damage.

Electrostatic discharge can affect electronic components. Take precautions during furnace installation and servicing to protect the furnace electronic control. Precautions will prevent electrostatic discharges from personnel and hand tools which are held during the procedure. These precautions will help to avoid exposing the control to electrostatic discharge by putting the furnace, the control, and the person at the same electrostatic potential.

START-UP CHECKLIST

(Remove and Store in Job Files)

I. PRELIMINARY INFORMATION

MODEL NO.: _____

SERIAL NO.: _____

DATE: _____

TECHNICIAN: _____

II. PRESTART-UP (Insert check mark in box as each item is completed)

- VERIFY THAT ALL PACKING MATERIALS HAVE BEEN REMOVED FROM UNIT
- REMOVE ALL SHIPPING HOLD DOWN BOLTS AND BRACKETS PER INSTALLATION INSTRUCTIONS
- CHECK ALL ELECTRICAL CONNECTIONS AND TERMINALS FOR TIGHTNESS
- CHECK GAS PIPING FOR LEAKS (WHERE APPLICABLE)
- CHECK THAT INDOOR (EVAPORATOR) AIR FILTER IS CLEAN AND IN PLACE
- VERIFY THAT UNIT INSTALLATION IS LEVEL
- CHECK FAN WHEEL, AND PROPELLER FOR LOCATION IN HOUSING/ORIFICE AND SETSCREW TIGHTNESS

III. START-UP

ELECTRICAL

SUPPLY VOLTAGE _____

COMPRESSOR AMPS _____

INDOOR (EVAPORATOR) FAN AMPS _____

TEMPERATURES

OUTDOOR (CONDENSER) AIR TEMPERATURE _____ DB

RETURN-AIR TEMPERATURE _____ DB _____ WB

COOLING SUPPLY AIR _____ DB _____ WB

HEAT PUMP SUPPLY AIR _____

GAS HEAT SUPPLY AIR _____

PRESSURES

GAS INLET PRESSURE _____ IN. W.C.

GAS MANIFOLD PRESSURE _____ IN. W.C.

REFRIGERANT SUCTION _____ PSIG, SUCTION LINE TEMP* _____

REFRIGERANT DISCHARGE _____ PSIG, LIQUID TEMP† _____

- VERIFY REFRIGERANT CHARGE USING CHARGING CHARTS

GAS HEAT TEMPERATURE RISE

TEMPERATURE RISE (See Literature) RANGE _____

MEASURED TEMPERATURE RISE _____

* Measured at suction inlet to compressor

† Measured at liquid line leaving condenser.