



14 SEER R-410A PACKAGE AIR CONDITIONER UNIT 23 to 58 MBTU/h

Two-Stage Electric Cooling

REFRIGERATION CIRCUIT

- All models are equipped with high efficiency two-stage Copeland UltraTech scroll compressor.
- Thermostatic Expansion Valve (TXV) on select models to control refrigerant flow.
- Variable Speed GE ECM 2.3 indoor motor with electronic speed controller on all models.
- High and Low Pressure Switches for excellent compressor protection.

BUILT TO LAST

- Galvanized-painted cabinet. One piece weather resistant top. Access panels for easy service. Side by side supply and return. Heavy gauge base rails.
- Triple-coated steel, consisting of a Polyester top coat, a urethane primer coat preceded by an oxide pretreatment.
- Integral base rails with fork-lift access on three sides. Holes provided for lifting lugs makes rooftop installation easier.
- The condenser coil has a sturdy wire inlet grille and UV rated vinyl mesh installed on the surface of the coil for additional protection.
- Advanced Air Management System for quieter operation.

EASY TO INSTALL AND SERVICE

- Combination electric cooling and electric heat, self contained for year-round comfort. Systems install on rooftop or ground level. The unit is shipped in the horizontal position and can easily be converted to downflow.
- Externally-mounted gauge ports allow for more accurate reading of operating conditions while servicing.
- Electrical controls located behind one exterior panel for easier maintenance.
- Dehumidification mode in cooling.
- Comfort Alert™ UltraTech™ Diagnostics device on all models.

ELECTRIC HEAT

- Slip in electrical heat from 5 to 20 kw, available as accessory.

WARRANTY

- 7 year No Hassle replacement limited warranty
- 10 year compressor limited warranty
- 7 year coil limited warranty
- 5 year parts limited warranty



This product has been designed and manufactured to meet ENERGY STAR criteria for energy efficiency. However, proper refrigerant charge and proper air flow are critical to achieve rated capacity and efficiency. Installation of this product should follow the manufacturer's refrigerant charging and air flow instructions. Failure to confirm proper charge and airflow may reduce energy efficiency and shorten equipment life.

No hassle

REPLACEMENT WARRANTY
see warranty certificate for details

UNIT PERFORMANCE DATA

Model Number	COOLING		Voltage - Phase - Hz	Unit Dimensions H x W x L*	Operating Weight
	Nominal Capacity BTUH	S.E.E.R			
PAX424000K00A	23,000	14.5	208/230-1-60	32-1/2 X 47-5/16 X 47-5/16	392
PAX430000K00A	29,000	14.5	208/230-1-60	32-1/2 X 47-5/16 X 47-5/16	392
PAX436000K00A	34,400	14.5	208/230-1-60	36 X 47-5/16 X 73	424
PAX442000K00A	41,000	14.5	208/230-1-60	36 X 47-5/16 X 73	550
PAX448000K00A	46,000	14.5	208/230-1-60	42 X 47-5/16 X 73	581
PAX460000K00A	58,000	14.5	208/230-1-60	42 X 47-5/16 X 73	606

* See unit dimensional drawings for mm.

UNIT SPECIFICATIONS

MODEL NUMBER	Electrical Data 208/230-1-60		Condenser Data									Sound Ratings (dBA)
			Coil			Fan Motor			Fan			
	Maximum HACR Breaker or Fuse	Minimum Circuit Ampacity	Total Face Area (Ft ²)	Fins Per Inch / Rows	Tube Diameter (Inch)	Horse Power	Full Load Amps	Locked Rotor Amps	Size Diameter (Inches)	RPM (Max.)	CFM (Design)	
PAX424000K00A	25 amps	18.1	11.40	18 / 2	3/8	1/8	0.9	1.6	20	825	2100	71
PAX430000K00A	35 amps	22.8	11.46	18 / 2	3/8	1/8	0.9	1.6	20	825	2100	71
PAX436000K00A	40 amps	26.1	12.99	18 / 2	3/8	1/8	0.9	1.7	20	1100	2600	73
PAX442000K00A	45 amps	28.6	17.12	18 / 2	3/8	1/8	0.9	1.7	22	1100	3100	78
PAX448000K00A	50 amps	34.7	20.14	18 / 2	3/8	1/4	1.4	3.2	22	1100	3400	77
PAX460000K00A	60 amps	42.5	20.14	18 / 2	3/8	1/4	1.4	3.2	22	1100	3400	77

MODEL NUMBER	Evaporator Coil								Scroll Compressor		Factory Refrigerant Charge R-410 (lbs)	Ship Weight (lbs)
	Coil			Motor		Blower			Rated Load Amps	Locked Rotor Amps		
	Total Face Area (Ft ²)	Fins Per Inch / Rows	Tube Diam. (Inch)	Horse Power	Full Load Amps	Size	RPM (Max)	CFM Rated				
PAX424000K00A	3.56	14 / 4	3/8	1/2	4.3	10 x 8	1260	800	10.3	52.0	10.30	402
PAX430000K00A	3.56	14 / 4	3/8	1/2	4.3	10 x 8	1260	875	14.1	70.0	10.55	402
PAX436000K00A	6.17	14 / 3	3/8	1/2	4.3	11 x 9	1260	1200	16.7	82.0	11.55	134
PAX442000K00A	6.17	14 / 3	3/8	3/4	6.8	11 x 9	1260	1400	16.7	96.0	14.30	560
PAX448000K00A	6.17	14 / 3	3/8	3/4	6.8	11 x 10	1260	1600	21.2	96.0	14.80	591
PAX460000K00A	9.76	14 / 3	3/8	1.0	9.1	11 x 10	1260	1750	25.6	118.0	15.80	616

PERFORMANCE DATA: COOLING

MODEL NUMBER	Rated Capacity ¹ BTUH	S / T Ratio	S.E.E.R.	E.E.R.	Evaporator Rated Airflow (SCFM)
PAX424000K00A	23,000	.76	14.5	11	800
PAX430000K00A	29,000	.79	14.5	11	1000
PAX436000K00A	34,400	.76	14.5	11	1200
PAX442000K00A	41,000	.76	14.5	11	1400
PAX448000K00A	46,000	.76	14.5	11	1600
PAX460000K00A	58,000	.76	14.5	11	1750

1. Rated Capacity @ ARI standard conditions, 95° Amb, 80° DB/67° WB, 230 Volts. For applications at 208 volts deduct 1000 BTUH.

ELECTRIC HEATER USAGE CHART

EHBA Heater Model No's (Example: EHBA05KN)								
Without Circuit Breakers	05KN		07KN		10KN			
With Circuit Breakers	05KB		07KB		10KB		15KB	20KB
Unit kW	5kW		7.5kW		10kW		15kW	20kW
PAX4	USED ON							
24	X	X	X	X	X	X		
30	X	X	X	X	X	X	X	
36	X	X	X	X	x	X	X	
42	X	X	X	X	x	X	X	X
48	X	X	X	X	x	X	X	X
60	X	X	X	X		X	X	X

PAX4 - ELECTRICAL DATA: ELECTRIC HEAT ACCESSORY

HEATER MODEL	Used With	Supply Voltage	kW Rating	Nominal Heating BTU/h	Supply Circuit No.	Heater Amps	Minimum Circuit Ampacity	Maximum Overcurrent Protective Device (Amps)
EHBA05KB	2 to 5 Ton	240-1-60	5.0	17,065	L3 - L4	20.8	26.0	30
EHBA05KN		208-1-60	3.75	12,798	L3 - L4	18.0	22.5	25
EHBA07KB	2 to 5 Ton	240-1-60	7.5	25,598	L3-L4	31.3	39.1	40
EHBA07KN		208-1-60	5.6	19,113	L3-L4	27.1	33.9	35
EHBA10KB	2 to 5 Ton	240-1-60	10.0	34,130	L3 - L4	41.7	52.1	60
		208-1-60	7.5	25,598	L3 - L4	36.2	45.3	45
EHBA10KN	2 to 4Ton	240-1-60	10.0	34,130	L3 - L4	41.7	52.1	60
		208-1-60	7.5	25,598	L3 - L4	36.2	45.3	45
EHBA15KB	2½ to 5 Ton	240-1-60	15.0	51,195	L3 - L4	41.7	52.1	60
					L5 - L6	20.8	26.0	30
		208-1-60	11.25	38,567	L3 - L4	36.2	45.3	45
					L5 - L6	18.0	22.5	25
EHBA20KB	3½ to 5 Ton	240-1-60	20	68,260	L3 - L4	41.7	52.1	60
					L5 - L6	41.7	52.1	60
		208-1-60	15.0	51,195	L3 - L4	36.2	45.3	45
					L5 - L6	36.2	45.3	45

AIRFLOW CHART

MODEL SIZE	COOLING												ELECTRIC HEAT				
	1st Stage						2nd Stage						5 kW	7.5 kW	10kW	15 kW	20 kW
	Rated SCFM			Dehum mode SCFM			Rated SCFM			Dehum mode SCFM							
	Low	Nominal	High	Low	Nominal	High	Low	Nominal	High	Low	Nominal	High					
24	504	560	616	403	448	493	720	800	880	576	640	704	850	850	850	-	-
30	585	650	715	468	520	572	788	875	963	630	700	770	850	850	850	1150	-
36	765	850	935	612	680	748	1080	1200	1320	864	960	1056	850	850	850	1150	-
42	878	975	1073	702	780	858	1260	1400	1540	1008	1120	1232	850	850	850	1150	1550
48	990	1100	1210	792	880	968	1440	1600	1760	1152	1280	1408	850	850	850	1150	1550
60	1170	1300	1430	936	1040	1144	1575	1750	1925	1260	1400	1540	850	850	850	1150	1550

EXPANDED PERFORMANCE DATA

SPECIFICATIONS SUBJECT TO CHANGE WITHOUT NOTICE

		P*X424 (High Stage Cooling)																								
		Outdoor Ambient Temperature - Degrees F, Dry Bulb																								
		75					85					95					105					115				
		Entering Indoor Temperature - Degrees F, Wet Bulb																								
CFM		57	62	63††	67	72	57	62	63††	67	72	57	62	63††	67	72	57	62	63††	67	72	57	62	63††	67	72
720	MBh†	22.16	22.85	23.34	25.10	27.60	21.30	21.75	22.21	23.90	26.28	20.38	20.61	21.03	22.63	24.90	19.41	19.42	19.78	21.30	23.45	18.36	18.36	18.46	19.89	21.91
	S/T‡	1.00	0.86	0.69	0.67	0.49	1.00	0.89	0.71	0.68	0.50	1.00	0.91	0.72	0.70	0.51	1.00	1.00	0.74	0.72	0.52	1.00	1.00	0.77	0.74	0.53
	AMPS*	7.00	7.04	7.06	7.17	7.32	7.89	7.92	7.94	8.06	8.21	8.85	8.87	8.90	9.01	9.17	9.90	9.90	9.93	10.05	10.21	11.03	11.03	11.04	11.16	11.33
	HI PR	282	284	285	288	293	325	326	327	331	336	372	373	374	378	384	424	424	425	430	435	481	481	482	486	491
	LO PR	129	133	135	145	159	132	135	137	147	161	136	137	139	150	164	139	139	141	152	166	144	144	144	154	168
800	MBh†	22.99	23.33	23.79	25.57	28.09	22.08	22.20	22.62	24.32	26.73	21.11	21.11	21.39	23.00	25.29	20.08	20.08	20.10	21.63	23.79	18.97	18.97	18.74	20.17	22.20
	S/T‡	1.00	0.90	0.72	0.69	0.51	1.00	0.92	0.73	0.71	0.51	1.00	1.00	0.75	0.72	0.52	1.00	1.00	0.77	0.75	0.54	1.00	1.00	0.80	0.77	0.55
	AMPS*	7.09	7.11	7.14	7.25	7.39	7.99	7.99	8.02	8.13	8.28	8.95	8.95	8.97	9.09	9.25	10.00	10.00	10.00	10.12	10.29	11.13	11.13	11.11	11.23	11.40
	HI PR	284	285	286	289	294	327	327	328	332	337	374	374	375	379	385	426	426	426	431	436	483	483	483	487	492
	LO PR	134	136	138	148	162	137	138	140	150	164	141	141	142	152	166	144	144	144	154	169	148	148	146	157	171
880	MBh†	23.72	23.77	24.15	25.95	28.50	22.76	22.76	22.95	24.66	27.09	21.74	21.74	21.68	23.30	25.61	20.66	20.66	20.36	21.89	24.07	19.50	19.50	18.96	20.40	22.44
	S/T‡	1.00	0.99	0.74	0.71	0.52	1.00	1.00	0.76	0.73	0.53	1.00	1.00	0.78	0.75	0.54	1.00	1.00	0.80	0.78	0.55	1.00	1.00	0.83	0.81	0.57
	AMPS*	7.19	7.19	7.21	7.32	7.46	8.08	8.08	8.09	8.20	8.36	9.05	9.05	9.04	9.16	9.32	10.10	10.10	10.07	10.19	10.36	11.23	11.23	11.18	11.30	11.47
	HI PR	286	286	287	290	295	329	329	329	333	338	376	376	376	380	386	428	428	427	431	437	485	485	483	488	493
	LO PR	138	139	140	151	165	142	142	142	153	167	145	145	144	155	169	149	149	146	157	171	152	152	148	159	173
		P*X424 (Low Stage Cooling)																								
		Outdoor Ambient Temperature - Degrees F, Dry Bulb																								
		75					85					95					105					115				
		Entering Indoor Temperature - Degrees F, Wet Bulb																								
CFM		57	62	63††	67	72	57	62	63††	67	72	57	62	63††	67	72	57	62	63††	67	72	57	62	63††	67	72
500	MBh†	15.83	16.66	17.10	18.61	20.78	15.15	15.75	16.17	17.64	19.75	14.45	14.82	15.22	16.65	18.70	13.74	13.88	14.26	15.64	17.62	13.03	13.03	13.30	14.62	16.52
	S/T‡	1.00	0.85	0.69	0.65	0.49	1.00	0.87	0.70	0.67	0.50	1.00	0.90	0.72	0.68	0.50	1.00	0.93	0.74	0.70	0.51	1.00	1.00	0.76	0.72	0.52
	AMPS*	4.88	4.91	4.92	4.96	5.01	5.57	5.60	5.62	5.68	5.75	6.34	6.37	6.39	6.48	6.58	7.22	7.23	7.27	7.39	7.52	8.24	8.24	8.27	8.42	8.59
	HI PR	271	273	274	278	282	313	315	316	320	325	360	361	363	367	372	413	413	414	419	425	471	471	472	477	483
	LO PR	127	132	135	144	157	131	135	137	147	160	135	137	140	149	163	139	140	142	152	165	143	143	145	154	168
550	MBh†	16.48	17.06	17.49	19.04	21.24	15.76	16.11	16.53	18.03	20.17	15.03	15.16	15.55	17.00	19.08	14.29	14.29	14.55	15.95	17.97	13.54	13.54	13.56	14.89	16.82
	S/T‡	1.00	0.88	0.70	0.67	0.50	1.00	0.91	0.72	0.69	0.51	1.00	0.94	0.74	0.71	0.51	1.00	1.00	0.76	0.73	0.52	1.00	1.00	0.79	0.75	0.53
	AMPS*	4.94	4.96	4.97	5.01	5.05	5.64	5.66	5.67	5.73	5.79	6.42	6.43	6.45	6.54	6.63	7.31	7.31	7.33	7.45	7.58	8.34	8.34	8.34	8.49	8.65
	HI PR	273	274	275	279	283	315	316	317	321	326	362	363	364	368	373	415	415	415	420	426	473	473	473	478	484
	LO PR	132	135	138	147	161	135	137	140	150	163	139	140	142	152	165	143	143	144	154	168	147	147	147	157	170
600	MBh†	17.07	17.40	17.83	19.39	21.63	16.32	16.44	16.83	18.35	20.52	15.56	15.56	15.82	17.29	19.40	14.78	14.78	14.80	16.22	18.26	13.99	13.99	13.77	15.13	17.08
	S/T‡	1.00	0.91	0.72	0.69	0.51	1.00	0.94	0.74	0.71	0.52	1.00	1.00	0.76	0.73	0.52	1.00	1.00	0.79	0.75	0.54	1.00	1.00	0.81	0.78	0.55
	AMPS*	5.00	5.01	5.02	5.06	5.09	5.70	5.71	5.73	5.78	5.84	6.50	6.50	6.51	6.59	6.68	7.40	7.40	7.39	7.51	7.63	8.44	8.44	8.41	8.55	8.71
	HI PR	274	275	276	279	284	317	317	318	322	327	364	364	365	369	374	416	416	416	421	427	475	475	474	479	485
	LO PR	136	138	140	150	163	139	140	142	152	165	143	143	144	154	168	147	147	146	156	170	151	151	149	159	172

† Total capacities are net (I.D blower heat subtracted).

* System amps are total of indoor and outdoor amps

‡ S/T are based on 80° F db entering air at the coil. For sensible capacities at other than 80° F db, deduct 835 BTU/h per 1000 cfm of indoor coil air from (MBh x S/T) for each degree below 80° F, or add 835 BTU/h per 1000 cfm of indoor coil air to (MBh x S/T) for each degree above 80° F

†† At TVA rating indoor condition (75° F db/ 63° F wb), All other indoor air temperatures are at 80° F db

EXPANDED PERFORMANCE DATA

		P*X430 (High Stage Cooling)																								
		Outdoor Ambient Temperature - Degrees F, Dry Bulb																								
		75					85					95					105					115				
		Entering Indoor Temperature - Degrees F, Wet Bulb																								
CFM		57	62	63††	67	72	57	62	63††	67	72	57	62	63††	67	72	57	62	63††	67	72	57	62	63††	67	72
787	MBh†	27.07	28.40	29.01	31.13	34.12	26.05	27.07	27.65	29.67	32.51	24.95	25.67	26.21	28.12	30.82	23.78	24.19	24.68	26.48	29.03	22.50	22.62	23.05	24.73	27.11
	S/T‡	1.00	0.86	0.70	0.67	0.50	1.00	0.88	0.71	0.68	0.51	1.00	0.90	0.72	0.69	0.52	1.00	0.93	0.74	0.71	0.52	1.00	0.96	0.76	0.73	0.54
	AMPS*	8.88	8.96	8.99	9.13	9.31	9.86	9.93	9.96	10.10	10.30	10.94	11.00	11.04	11.18	11.39	12.16	12.20	12.23	12.39	12.60	13.54	13.55	13.58	13.74	13.96
	HI PR	296	300	301	306	313	340	343	345	350	357	389	391	392	398	406	442	443	444	450	458	499	500	501	507	515
	LO PR	121	127	129	139	153	124	129	131	141	155	127	131	133	144	157	131	133	136	146	160	135	136	138	149	163
875	MBh†	28.11	29.01	29.60	31.74	34.76	27.02	27.62	28.17	30.21	33.09	25.85	26.17	26.67	29.00	31.32	24.60	24.66	25.08	26.90	29.46	23.25	23.25	23.39	25.08	27.48
	S/T‡	1.00	0.89	0.72	0.69	0.51	1.00	0.91	0.73	0.70	0.52	1.00	0.94	0.75	0.72	0.53	1.00	0.99	0.77	0.74	0.54	1.00	1.00	0.79	0.77	0.55
	AMPS*	9.02	9.08	9.11	9.25	9.44	10.01	10.05	10.08	10.22	10.42	11.10	11.12	11.15	11.30	11.51	12.32	12.32	12.35	12.51	12.72	13.70	13.69	13.70	13.86	14.08
	HI PR	299	301	302	308	315	343	345	346	352	359	392	393	394	400	407	445	445	446	452	460	502	502	502	508	516
	LO PR	126	130	132	142	156	129	132	134	144	158	132	134	136	146	160	136	137	138	149	163	140	140	141	151	165
962	MBh†	29.01	29.51	30.07	32.23	35.27	27.86	28.10	28.59	30.64	33.54	26.63	26.64	27.04	28.98	31.72	25.31	25.31	25.40	27.22	29.80	23.89	23.89	23.66	25.36	27.77
	S/T‡	1.00	0.93	0.74	0.71	0.52	1.00	0.95	0.75	0.73	0.53	1.00	1.00	0.77	0.75	0.54	1.00	1.00	0.80	0.77	0.55	1.00	1.00	0.82	0.80	0.57
	AMPS*	9.16	9.19	9.22	9.36	9.55	10.15	10.16	10.19	10.34	10.54	11.24	11.24	11.27	11.42	11.62	12.46	12.46	12.46	12.62	12.84	13.84	13.84	13.81	13.97	14.19
	HI PR	301	303	304	309	316	346	346	347	353	361	394	394	395	401	409	447	447	447	453	461	505	505	504	509	517
	LO PR	130	133	135	145	159	134	135	137	147	161	137	137	139	149	163	141	141	141	151	165	145	145	143	153	168
		P*X430 (Low Stage Cooling)																								
		Outdoor Ambient Temperature - Degrees F, Dry Bulb																								
		75					85					95					105					115				
		Entering Indoor Temperature - Degrees F, Wet Bulb																								
CFM		57	62	63††	67	72	57	62	63††	67	72	57	62	63††	67	72	57	62	63††	67	72	57	62	63††	67	72
580	MBh†	18.92	20.33	20.85	22.65	25.21	18.22	19.37	19.87	21.60	24.06	17.45	18.34	18.81	20.46	22.82	16.62	17.22	17.67	19.24	21.49	15.72	16.03	16.45	17.94	20.07
	S/T‡	1.00	0.90	0.73	0.70	0.53	1.00	0.92	0.75	0.71	0.54	1.00	0.94	0.76	0.73	0.54	1.00	0.97	0.78	0.74	0.55	1.00	1.01	0.80	0.76	0.56
	AMPS*	6.07	6.14	6.16	6.25	6.38	6.88	6.94	6.97	7.06	7.19	7.82	7.87	7.90	8.00	8.13	8.92	8.96	8.98	9.09	9.22	10.21	10.23	10.26	10.37	10.51
	HI PR	280	284	285	290	296	323	326	328	333	340	370	373	375	380	388	422	424	426	432	439	479	481	482	488	496
	LO PR	119	126	129	138	150	122	128	131	140	153	126	131	133	143	156	130	134	136	146	159	135	136	139	148	162
650	MBh†	19.87	20.94	21.47	23.31	25.94	19.12	19.93	20.43	22.20	24.71	18.30	18.84	19.31	21.00	23.40	17.41	17.68	18.11	19.72	22.01	16.44	16.46	16.83	18.35	20.51
	S/T‡	1.00	0.93	0.75	0.72	0.54	1.00	0.96	0.77	0.73	0.55	1.00	0.98	0.78	0.75	0.55	1.00	1.01	0.81	0.77	0.56	1.00	1.00	0.83	0.80	0.58
	AMPS*	6.17	6.22	6.24	6.34	6.46	6.98	7.03	7.05	7.15	7.27	7.92	7.96	7.98	8.08	8.21	9.02	9.04	9.07	9.17	9.31	10.32	10.32	10.34	10.45	10.59
	HI PR	283	285	287	292	298	326	328	329	335	342	373	375	376	382	390	425	426	428	433	441	483	483	484	490	498
	LO PR	124	130	132	141	154	127	132	134	144	157	131	134	136	146	159	135	137	139	149	162	139	140	142	151	165
715	MBh†	20.67	21.43	21.94	23.82	26.49	19.86	20.37	20.86	22.66	25.21	18.99	19.25	19.69	21.41	23.85	18.05	18.07	18.45	20.08	22.39	17.03	17.03	17.12	18.66	20.85
	S/T‡	1.00	0.96	0.77	0.74	0.55	1.00	0.99	0.79	0.76	0.56	1.00	1.02	0.81	0.77	0.57	1.00	1.00	0.83	0.80	0.58	1.00	1.00	0.86	0.82	0.59
	AMPS*	6.25	6.29	6.32	6.41	6.54	7.07	7.10	7.12	7.22	7.35	8.01	8.03	8.05	8.15	8.29	9.11	9.11	9.14	9.24	9.38	10.41	10.41	10.41	10.52	10.66
	HI PR	285	287	288	293	300	328	330	331	336	344	376	376	378	383	391	428	428	429	435	443	485	485	485	491	499
	LO PR	129	132	135	144	157	132	134	137	146	160	135	137	139	149	162	139	139	141	151	165	144	144	144	154	167

† Total capacities are net (I.D blower heat subtracted).

* System amps are total of indoor and outdoor amps

‡ S/T are based on 80° F db entering air at the indoor coil. For sensible capacities at other than 80° F db, deduct 835 BTU/h per 1000 cfm of indoor coil air from (MBh x S/T) for each degree below 80° F, or add 835 BTU/h per 1000 cfm of indoor coil air to (MBh x S/T) for each degree above 80° F

†† At TVA rating indoor condition (75° F db/ 63° F wb), All other indoor air temperatures are at 80° F db

5

SPECIFICATIONS SUBJECT TO CHANGE WITHOUT NOTICE

EXPANDED PERFORMANCE DATA

SPECIFICATIONS SUBJECT TO CHANGE WITHOUT NOTICE

		P*X436 (High Stage Cooling)																								
		Outdoor Ambient Temperature - Degrees F, Dry Bulb																								
		75					85					95					105					115				
		Entering Indoor Temperature - Degrees F, Wet Bulb																								
CFM		57	62	63††	67	72	57	62	63††	67	72	57	62	63††	67	72	57	62	63††	67	72	57	62	63††	67	72
1080	MBh†	33.33	34.47	35.23	38.02	41.96	31.95	32.69	33.40	36.07	39.85	30.49	30.85	31.49	34.04	37.65	28.95	28.98	29.50	31.92	35.36	27.31	27.31	27.41	29.69	32.94
	S/T‡	1.00	0.86	0.69	0.66	0.49	1.00	0.88	0.70	0.68	0.50	1.00	0.91	0.72	0.69	0.51	1.00	1.00	0.74	0.71	0.52	1.00	1.00	0.77	0.74	0.53
	AMPS*	10.59	10.62	10.64	10.72	10.82	11.94	11.96	11.98	12.07	12.18	13.41	13.43	13.45	13.54	13.66	15.03	15.03	15.05	15.15	15.28	16.79	16.79	16.79	16.90	17.04
	HI PR	281	283	284	287	292	324	325	326	330	335	371	372	373	377	382	423	423	424	428	434	480	480	481	485	490
	LO PR	127	130	133	143	156	130	133	135	145	158	134	135	137	147	161	138	138	140	150	163	142	142	142	152	166
1200	MBh†	34.59	35.19	35.91	38.73	42.73	33.12	33.37	34.00	36.71	40.54	31.58	31.57	32.02	34.40	38.25	29.96	29.96	29.97	32.41	35.88	28.23	28.23	27.81	30.11	33.39
	S/T‡	1.00	0.89	0.71	0.68	0.50	1.00	0.92	0.73	0.70	0.51	1.00	1.00	0.75	0.72	0.52	1.00	1.00	0.77	0.74	0.53	1.00	1.00	0.80	0.77	0.55
	AMPS*	10.74	10.76	10.78	10.85	10.95	12.09	12.10	12.12	12.20	12.31	13.57	13.57	13.58	13.67	13.79	15.19	15.19	15.19	15.29	15.41	16.95	16.95	16.93	17.04	17.17
	HI PR	283	284	285	288	293	326	326	327	331	336	373	373	374	378	383	425	425	425	429	435	482	482	481	486	491
	LO PR	131	133	135	145	159	135	136	138	148	161	138	138	140	150	163	142	142	142	152	166	147	147	144	155	168
1320	MBh†	35.70	35.85	36.45	39.31	43.36	34.15	34.15	34.49	37.22	41.10	32.53	32.53	32.46	35.05	38.74	30.83	30.83	30.35	32.80	36.30	29.02	29.02	28.14	30.45	33.74
	S/T‡	1.00	0.93	0.73	0.71	0.51	1.00	1.00	0.75	0.73	0.52	1.00	1.00	0.78	0.75	0.54	1.00	1.00	0.80	0.77	0.55	1.00	1.00	0.83	0.80	0.56
	AMPS*	10.89	10.89	10.91	10.98	11.08	12.24	12.24	12.25	12.33	12.44	13.72	13.72	13.72	13.81	13.92	15.34	15.34	15.32	15.42	15.54	17.11	17.11	17.06	17.17	17.30
	HI PR	284	285	285	289	294	328	328	328	332	337	375	375	375	379	384	427	427	426	430	436	484	484	482	486	492
	LO PR	136	136	138	148	161	139	139	140	150	163	143	143	142	152	166	146	146	144	154	168	151	151	146	157	170

		P*X436 (Low Stage Cooling)																								
		Outdoor Ambient Temperature - Degrees F, Dry Bulb																								
		75					85					95					105					115				
		Entering Indoor Temperature - Degrees F, Wet Bulb																								
CFM		57	62	63††	67	72	57	62	63††	67	72	57	62	63††	67	72	57	62	63††	67	72	57	62	63††	67	72
770	MBh†	23.90	24.67	25.29	27.48	30.64	22.75	23.18	23.75	25.84	28.85	21.57	21.67	22.18	24.17	27.05	20.35	20.35	20.57	22.46	25.19	19.08	19.08	18.92	20.69	23.26
	S/T‡	1.00	0.89	0.71	0.68	0.51	1.00	0.92	0.73	0.70	0.51	1.00	0.95	0.75	0.72	0.52	1.00	1.00	0.78	0.75	0.54	1.00	1.00	0.81	0.78	0.55
	AMPS*	6.27	6.09	5.96	5.43	4.69	7.66	7.57	7.45	6.96	6.27	9.19	9.17	9.07	8.60	7.95	10.87	10.87	10.84	10.40	9.77	12.75	12.75	12.81	12.40	11.81
	HI PR	272	273	274	276	279	316	316	317	320	324	363	363	364	367	371	417	417	417	420	424	477	477	476	480	484
	LO PR	131	135	137	147	160	135	137	140	149	163	140	140	142	152	166	144	144	145	155	168	149	149	148	158	171
850	MBh†	24.83	25.22	25.80	28.04	31.26	23.61	23.69	24.20	26.33	29.41	22.37	22.37	22.58	24.60	27.53	21.08	21.08	20.92	22.83	25.60	19.74	19.74	19.21	21.01	23.62
	S/T‡	1.00	0.93	0.74	0.70	0.52	1.00	0.99	0.76	0.72	0.53	1.00	1.00	0.78	0.75	0.54	1.00	1.00	0.81	0.78	0.55	1.00	1.00	0.85	0.81	0.57
	AMPS*	6.11	6.02	5.89	5.35	4.60	7.52	7.50	7.40	6.90	6.19	9.06	9.06	9.03	8.56	7.88	10.76	10.76	10.82	10.37	9.73	12.66	12.66	12.80	12.38	11.78
	HI PR	274	274	275	277	280	317	317	318	321	324	365	365	365	368	372	418	418	418	421	425	478	478	477	480	484
	LO PR	136	137	140	150	163	140	140	142	152	166	144	144	145	155	168	148	148	147	157	171	153	153	150	160	174
940	MBh†	25.76	25.79	26.28	28.56	31.84	24.48	24.48	24.62	26.79	29.92	23.16	23.16	22.95	25.00	27.97	21.81	21.81	21.24	23.18	25.98	20.39	20.39	19.49	21.30	23.94
	S/T‡	1.00	1.00	0.76	0.73	0.53	1.00	1.00	0.78	0.75	0.54	1.00	1.00	0.81	0.78	0.55	1.00	1.00	0.84	0.81	0.57	1.00	1.00	0.88	0.85	0.59
	AMPS*	5.94	5.94	5.84	5.28	4.52	7.38	7.38	7.37	6.85	6.13	8.94	8.94	9.01	8.52	7.84	10.66	10.66	10.81	10.35	9.69	12.57	12.57	12.80	12.37	11.76
	HI PR	275	275	275	277	280	318	318	318	321	325	366	366	366	369	373	419	419	418	422	426	479	479	478	481	485
	LO PR	140	140	142	152	166	144	144	144	155	168	148	148	147	157	171	152	152	149	159	173	157	157	152	162	176

6

† Total capacities are net (I.D blower heat subtracted).

* System amps are total of indoor and outdoor amps

‡ S/T are based on 80° F db entering air at the coil. For sensible capacities at other than 80° F db, deduct 835 BTU/h per 1000 cfm of indoor coil air from (MBh x S/T) for each degree below 80° F, or add 835 BTU/h per 1000 cfm of indoor coil air to (MBh x S/T) for each degree above 80° F

†† At TVA rating indoor condition (75° F db/ 63° F wb), All other indoor air temperatures are at 80° F db

EXPANDED PERFORMANCE DATA

		P*X442 (High Stage Cooling)																								
		Outdoor Ambient Temperature - Degrees F, Dry Bulb																								
		75					85					95					105					115				
		Entering Indoor Temperature - Degrees F, Wet Bulb																								
CFM		57	62	63††	67	72	57	62	63††	67	72	57	62	63††	67	72	57	62	63††	67	72	57	62	63††	67	72
1260	MBh†	38.35	39.47	40.31	43.44	47.86	36.97	37.72	38.49	41.49	45.73	35.47	35.85	36.55	39.41	43.45	33.85	33.90	34.46	37.17	41.01	32.07	32.07	32.20	34.75	38.37
	S/T‡	1.00	0.86	0.69	0.67	0.49	1.00	0.88	0.71	0.68	0.50	1.00	0.91	0.72	0.69	0.51	1.00	0.99	0.74	0.71	0.52	1.00	1.00	0.76	0.74	0.53
	AMPS*	12.77	12.83	12.86	13.03	13.25	14.02	14.06	14.10	14.27	14.50	15.39	15.41	15.44	15.62	15.85	16.89	16.89	16.92	17.10	17.35	18.57	18.57	18.57	18.75	19.00
	HI PR	286	287	288	293	299	329	330	331	336	342	376	377	378	383	390	428	428	429	434	441	485	485	485	490	497
	LO PR	126	129	132	141	154	129	131	133	143	156	132	133	135	145	159	136	136	137	147	161	140	140	140	150	163
1400	MBh†	39.73	40.27	41.02	44.19	48.68	38.26	38.47	39.13	42.16	46.46	36.68	36.66	37.11	41.00	44.09	34.96	34.96	34.96	37.69	41.56	33.08	33.08	32.64	35.20	38.84
	S/T‡	1.00	0.90	0.72	0.69	0.51	1.00	0.92	0.73	0.70	0.51	1.00	1.00	0.75	0.72	0.52	1.00	1.00	0.77	0.74	0.53	1.00	1.00	0.80	0.77	0.55
	AMPS*	13.00	13.02	13.06	13.22	13.45	14.25	14.26	14.29	14.46	14.69	15.61	15.61	15.63	15.81	16.05	17.12	17.12	17.11	17.29	17.54	18.80	18.80	18.76	18.94	19.19
	HI PR	288	289	289	294	300	331	332	332	337	344	379	379	379	384	391	431	431	430	436	443	487	487	486	492	498
	LO PR	131	132	134	144	157	133	134	136	146	159	137	137	138	148	161	140	140	140	150	163	144	144	142	152	166
1540	MBh†	40.94	41.01	41.59	44.80	49.33	39.39	39.39	39.64	42.70	47.04	37.72	37.72	37.57	40.48	44.60	35.92	35.92	35.36	38.10	42.00	33.95	33.95	32.98	35.56	39.20
	S/T‡	1.00	0.93	0.74	0.71	0.52	1.00	1.00	0.76	0.73	0.53	1.00	1.00	0.77	0.75	0.54	1.00	1.00	0.80	0.77	0.55	1.00	1.00	0.83	0.80	0.56
	AMPS*	13.21	13.22	13.24	13.41	13.64	14.47	14.47	14.47	14.65	14.88	15.83	15.83	15.82	15.99	16.24	17.34	17.34	17.29	17.48	17.72	19.02	19.02	18.94	19.12	19.37
	HI PR	290	290	290	295	301	333	333	333	338	345	381	381	380	385	392	433	433	431	437	444	489	489	487	492	499
	LO PR	135	135	136	146	160	138	138	138	148	162	141	141	140	150	163	144	144	142	152	165	148	148	144	154	168
		P*X442 (Low Stage Cooling)																								
		Outdoor Ambient Temperature - Degrees F, Dry Bulb																								
		75					85					95					105					115				
		Entering Indoor Temperature - Degrees F, Wet Bulb																								
CFM		57	62	63††	67	72	57	62	63††	67	72	57	62	63††	67	72	57	62	63††	67	72	57	62	63††	67	72
880	MBh†	27.85	28.86	29.57	32.11	35.76	26.83	27.53	28.19	30.64	34.15	25.73	26.10	26.71	29.06	32.43	24.53	24.59	25.12	27.36	30.58	23.21	23.21	23.40	25.52	28.58
	S/T‡	1.00	0.91	0.73	0.69	0.52	1.00	0.93	0.74	0.71	0.52	1.00	0.95	0.76	0.72	0.53	1.00	0.99	0.78	0.74	0.54	1.00	1.00	0.80	0.77	0.55
	AMPS*	8.67	8.66	8.65	8.63	8.61	9.64	9.63	9.62	9.58	9.54	10.73	10.72	10.71	10.65	10.59	11.98	11.98	11.97	11.89	11.80	13.45	13.45	13.45	13.35	13.24
	HI PR	272	274	275	279	284	315	316	317	321	327	362	363	364	368	374	414	414	415	420	426	472	472	472	477	483
	LO PR	129	133	135	145	158	132	135	137	147	160	135	137	139	149	162	139	139	141	151	165	143	143	144	154	167
975	MBh†	28.96	29.51	30.18	32.78	36.50	27.88	28.14	28.75	31.25	34.83	26.71	26.70	27.22	29.60	33.03	25.44	25.44	25.57	27.84	31.11	24.05	24.05	23.78	25.93	29.04
	S/T‡	1.00	0.94	0.75	0.72	0.53	1.00	0.96	0.76	0.73	0.53	1.00	1.00	0.78	0.75	0.54	1.00	1.00	0.81	0.77	0.55	1.00	1.00	0.83	0.80	0.57
	AMPS*	8.74	8.74	8.73	8.71	8.69	9.70	9.70	9.69	9.65	9.61	10.79	10.79	10.78	10.72	10.66	12.03	12.03	12.03	11.96	11.87	13.49	13.49	13.51	13.42	13.30
	HI PR	274	275	276	280	285	317	317	318	322	328	364	364	365	369	375	416	416	416	421	427	474	474	473	478	484
	LO PR	134	136	138	148	161	137	138	140	149	163	140	140	142	151	165	143	143	144	154	167	148	148	146	156	170
1075	MBh†	30.00	30.13	30.72	33.36	37.15	28.86	28.86	29.24	31.77	35.41	27.62	27.62	27.65	30.07	33.55	26.28	26.28	25.95	28.25	31.56	24.82	24.82	24.12	26.29	29.43
	S/T‡	1.00	0.98	0.77	0.74	0.54	1.00	1.00	0.79	0.76	0.55	1.00	1.00	0.81	0.78	0.56	1.00	1.00	0.84	0.80	0.57	1.00	1.00	0.87	0.83	0.59
	AMPS*	8.82	8.82	8.81	8.79	8.77	9.78	9.78	9.77	9.73	9.69	10.85	10.85	10.85	10.80	10.74	12.09	12.09	12.11	12.03	11.95	13.54	13.54	13.58	13.49	13.37
	HI PR	276	276	277	281	286	319	319	319	323	329	366	366	366	370	376	418	418	417	422	428	476	476	474	479	485
	LO PR	138	138	140	150	163	141	141	142	152	165	144	144	144	154	167	148	148	146	156	169	152	152	148	158	172

† Total capacities are net (I.D blower heat subtracted).

* System amps are total of indoor and outdoor amps

‡ S/T are based on 80° F db entering air at the indoor coil. For sensible capacities at other than 80° F db, deduct 835 BTU/h per 1000 cfm of indoor coil air from (MBh x S/T) for each degree below 80° F, or add 835 BTU/h per 1000 cfm of indoor coil air to (MBh x S/T) for each degree above 80° F

†† At TVA rating indoor condition (75° F db/ 63° F wb), All other indoor air temperatures are at 80° F db

7 SPECIFICATIONS SUBJECT TO CHANGE WITHOUT NOTICE

EXPANDED PERFORMANCE DATA

SPECIFICATIONS SUBJECT TO CHANGE WITHOUT NOTICE

		P*X448 (High Stage Cooling)																								
		Outdoor Ambient Temperature - Degrees F, Dry Bulb																								
		75					85					95					105					115				
		Entering Indoor Temperature - Degrees F, Wet Bulb																								
CFM		57	62	63††	67	72	57	62	63††	67	72	57	62	63††	67	72	57	62	63††	67	72	57	62	63††	67	72
1440	MBh†	44.14	45.41	46.32	49.97	55.13	42.56	43.42	44.24	47.74	52.67	40.84	41.29	42.01	45.34	50.05	38.97	39.05	39.60	42.76	47.22	36.91	36.91	37.01	39.98	44.18
	S/T‡	1.00	0.87	0.69	0.67	0.49	1.00	0.88	0.71	0.68	0.50	1.00	0.91	0.72	0.69	0.51	1.00	0.93	0.74	0.71	0.52	1.00	1.00	0.76	0.74	0.53
	AMPS*	14.79	14.86	14.90	15.09	15.35	16.17	16.22	16.26	16.46	16.72	17.68	17.70	17.74	17.94	18.22	19.33	19.34	19.37	19.58	19.87	21.18	21.18	21.18	21.39	21.69
	HI PR	288	290	291	296	302	331	333	334	339	346	379	380	381	386	393	431	431	432	437	445	487	487	487	493	500
	LO PR	127	130	132	142	155	130	132	134	144	157	133	135	136	146	160	137	137	139	149	162	141	141	141	151	165
1600	MBh†	45.70	46.32	47.11	50.81	56.03	44.02	44.30	44.95	48.49	53.49	42.20	42.16	42.64	46.00	50.77	40.22	40.22	40.16	43.34	47.84	38.05	38.05	37.49	40.48	44.70
	S/T‡	1.00	0.90	0.72	0.69	0.51	1.00	0.92	0.73	0.70	0.51	1.00	1.00	0.75	0.72	0.52	1.00	1.00	0.77	0.74	0.53	1.00	1.00	0.80	0.77	0.55
	AMPS*	15.07	15.10	15.14	15.33	15.60	16.45	16.47	16.50	16.70	16.97	17.96	17.96	17.98	18.18	18.46	19.62	19.62	19.61	19.82	20.11	21.46	21.46	21.42	21.63	21.93
	HI PR	290	291	292	297	303	334	334	335	340	347	381	381	382	387	395	433	433	433	439	446	490	490	489	494	502
	LO PR	131	133	135	145	158	134	135	137	147	160	138	138	139	149	162	142	141	141	151	165	146	146	143	153	167
1760	MBh†	47.06	47.19	47.74	51.48	56.76	45.29	45.28	45.52	49.08	54.14	43.38	43.37	43.15	46.53	51.33	41.30	41.30	40.61	43.81	48.33	39.03	39.03	37.88	40.88	45.10
	S/T‡	1.00	0.93	0.74	0.71	0.52	1.00	1.00	0.75	0.73	0.53	1.00	1.00	0.77	0.75	0.54	1.00	1.00	0.80	0.77	0.55	1.00	1.00	0.83	0.80	0.56
	AMPS*	15.34	15.35	15.37	15.57	15.84	16.72	16.72	16.73	16.93	17.21	18.23	18.23	18.21	18.42	18.70	19.89	19.89	19.84	20.05	20.34	21.74	21.74	21.65	21.86	22.16
	HI PR	292	292	293	298	304	336	336	336	341	348	384	384	383	388	396	435	435	434	440	447	492	492	490	495	503
	LO PR	135	136	137	147	160	138	138	139	149	162	142	142	141	151	164	145	145	143	153	167	149	149	145	155	169
		P*X448 (Low Stage Cooling)																								
		Outdoor Ambient Temperature - Degrees F, Dry Bulb																								
		75					85					95					105					115				
		Entering Indoor Temperature - Degrees F, Wet Bulb																								
CFM		57	62	63††	67	72	57	62	63††	67	72	57	62	63††	67	72	57	62	63††	67	72	57	62	63††	67	72
1000	MBh†	30.91	32.03	32.78	35.65	39.76	29.79	30.56	31.26	34.02	37.97	28.57	28.99	29.62	32.26	36.05	27.23	27.32	27.85	30.37	33.99	25.76	25.76	25.94	28.32	31.75
	S/T‡	1.00	0.91	0.73	0.70	0.52	1.00	0.93	0.74	0.71	0.52	1.00	0.95	0.76	0.73	0.53	1.00	0.98	0.78	0.75	0.54	1.00	1.00	0.80	0.77	0.55
	AMPS*	9.66	9.65	9.64	9.62	9.61	10.79	10.78	10.77	10.73	10.69	12.06	12.05	12.04	11.98	11.91	13.52	13.52	13.50	13.42	13.33	15.22	15.22	15.22	15.12	14.99
	HI PR	273	275	276	280	285	316	317	318	323	328	363	364	365	369	376	415	415	416	421	427	472	472	472	477	484
	LO PR	129	133	135	145	157	132	135	137	147	160	136	137	139	149	162	139	140	142	151	165	144	144	144	154	168
1100	MBh†	32.04	32.70	33.40	36.32	40.51	30.85	31.19	31.82	34.62	38.65	29.56	29.62	30.12	32.80	36.66	28.15	28.15	28.29	30.85	34.52	26.61	26.61	26.32	28.73	32.21
	S/T‡	1.00	0.94	0.75	0.72	0.53	1.00	0.96	0.76	0.73	0.53	1.00	0.99	0.78	0.75	0.54	1.00	1.00	0.81	0.77	0.55	1.00	1.00	0.83	0.80	0.57
	AMPS*	9.76	9.76	9.75	9.74	9.72	10.89	10.88	10.88	10.84	10.80	12.15	12.15	12.14	12.08	12.02	13.60	13.60	13.60	13.52	13.43	15.30	15.30	15.31	15.21	15.09
	HI PR	275	276	277	281	286	318	319	324	330	336	365	365	366	370	377	417	417	417	422	428	474	474	473	478	485
	LO PR	133	135	137	147	160	136	138	139	149	162	140	140	141	151	165	144	144	144	154	167	148	148	146	156	170
1200	MBh†	33.06	33.31	33.91	36.88	41.14	31.81	31.82	32.28	35.13	39.21	30.45	30.45	30.54	33.25	37.16	28.97	28.97	28.66	31.24	34.95	27.36	27.36	26.64	29.08	32.58
	S/T‡	1.00	0.97	0.77	0.74	0.54	1.00	1.00	0.79	0.75	0.55	1.00	1.00	0.81	0.77	0.56	1.00	1.00	0.83	0.80	0.57	1.00	1.00	0.86	0.83	0.58
	AMPS*	9.87	9.87	9.87	9.85	9.84	10.99	10.98	10.98	10.95	10.91	12.24	12.24	12.24	12.19	12.13	13.69	13.69	13.70	13.63	13.54	15.38	15.38	15.41	15.31	15.19
	HI PR	277	277	278	282	287	320	319	320	325	331	367	367	367	371	378	419	419	418	423	429	476	476	474	479	486
	LO PR	137	138	139	149	162	140	141	141	151	165	143	143	143	153	167	147	147	146	156	169	151	151	148	158	172

8

† Total capacities are net (I.D blower heat subtracted).

* System amps are total of indoor and outdoor amps

‡ S/T are based on 80° F db entering air at the coil. For sensible capacities at other than 80° F db, deduct 835 BTU/h per 1000 cfm of indoor coil air from (MBh x S/T) for each degree below 80° F, or add 835 BTU/h per 1000 cfm of indoor coil air to (MBh x S/T) for each degree above 80° F

†† At TVA rating indoor condition (75° F db/ 63° F wb), All other indoor air temperatures are at 80° F db

EXPANDED PERFORMANCE DATA

		P*X460 (High Stage Cooling)																								
		Outdoor Ambient Temperature - Degrees F, Dry Bulb																								
		75					85					95					105					115				
		Entering Indoor Temperature - Degrees F, Wet Bulb																								
CFM		57	62	63††	67	72	57	62	63††	67	72	57	62	63††	67	72	57	62	63††	67	72	57	62	63††	67	72
1575	MBh†	53.72	56.33	57.55	61.78	67.72	51.82	53.85	55.01	59.04	64.71	49.75	51.20	52.29	56.12	61.50	47.50	48.36	49.36	52.97	58.05	45.03	45.31	46.18	49.57	54.30
	S/T‡	1.00	0.86	0.70	0.67	0.50	1.00	0.88	0.71	0.68	0.51	1.00	0.90	0.72	0.69	0.52	1.00	0.93	0.74	0.71	0.52	1.00	0.96	0.76	0.73	0.54
	AMPS*	17.81	17.98	18.05	18.33	18.73	19.67	19.81	19.89	20.17	20.58	21.70	21.82	21.89	22.19	22.61	23.96	24.03	24.10	24.41	24.84	26.46	26.48	26.55	26.86	27.30
	HI PR	302	305	307	312	320	347	350	351	357	365	396	399	400	406	414	450	451	453	459	468	508	509	510	516	525
	LO PR	122	128	130	140	154	125	130	132	142	156	128	132	134	144	158	132	134	137	147	161	136	137	139	149	163
1750	MBh†	55.71	57.45	58.64	62.91	68.92	53.67	54.87	55.98	60.05	65.78	51.47	52.13	53.14	58.00	62.43	49.08	49.24	50.09	53.73	58.85	46.47	46.47	46.81	50.21	54.96
	S/T‡	1.00	0.90	0.72	0.69	0.51	1.00	0.92	0.73	0.70	0.52	1.00	0.94	0.75	0.72	0.53	1.00	0.97	0.77	0.74	0.54	1.00	1.00	0.79	0.76	0.55
	AMPS*	18.20	18.32	18.39	18.67	19.07	20.06	20.15	20.22	20.51	20.92	22.10	22.15	22.22	22.53	22.95	24.36	24.37	24.43	24.74	25.18	26.86	26.86	26.88	27.19	27.63
	HI PR	305	307	308	314	321	350	352	353	359	367	399	400	402	408	416	453	453	455	461	469	511	511	512	518	526
	LO PR	127	131	133	143	157	130	133	135	145	159	133	135	137	147	161	137	137	139	150	164	141	141	142	152	166
1925	MBh†	57.44	58.39	59.50	63.81	69.87	55.29	55.76	56.74	60.84	66.62	52.97	53.01	53.81	57.69	63.16	50.45	50.45	50.67	54.32	59.46	47.69	47.69	47.29	50.70	55.46
	S/T‡	1.00	0.93	0.74	0.71	0.53	1.00	0.95	0.76	0.73	0.53	1.00	1.00	0.77	0.75	0.54	1.00	1.00	0.80	0.77	0.55	1.00	1.00	0.82	0.80	0.57
	AMPS*	18.58	18.64	18.71	19.00	19.40	20.44	20.48	20.54	20.84	21.25	22.49	22.49	22.54	22.85	23.27	24.74	24.74	24.75	25.06	25.50	27.24	27.24	27.19	27.51	27.95
	HI PR	307	309	310	315	323	353	353	355	360	368	402	402	403	409	418	456	456	456	462	471	514	514	513	519	528
	LO PR	131	134	136	146	160	134	136	137	148	162	138	138	139	150	164	141	141	141	152	166	145	145	144	154	169
		P*X460 (Low Stage Cooling)																								
		Outdoor Ambient Temperature - Degrees F, Dry Bulb																								
		75					85					95					105					115				
		Entering Indoor Temperature - Degrees F, Wet Bulb																								
CFM		57	62	63††	67	72	57	62	63††	67	72	57	62	63††	67	72	57	62	63††	67	72	57	62	63††	67	72
1175	MBh†	38.90	40.54	41.49	44.80	49.51	37.56	38.79	39.69	42.87	47.41	36.09	36.89	37.75	40.79	45.14	34.50	34.86	35.65	38.56	42.71	32.76	32.77	33.40	36.15	40.10
	S/T‡	1.00	0.90	0.72	0.69	0.52	1.00	0.92	0.74	0.71	0.52	1.00	0.94	0.75	0.72	0.53	1.00	0.97	0.77	0.74	0.54	1.00	1.00	0.79	0.76	0.55
	AMPS*	11.80	11.78	11.77	11.73	11.69	13.33	13.30	13.29	13.22	13.15	15.06	15.03	15.01	14.92	14.81	17.05	17.03	17.01	16.88	16.73	19.37	19.37	19.35	19.18	18.97
	HI PR	280	282	283	287	292	323	325	326	330	336	371	372	373	378	384	423	424	425	430	436	481	482	482	487	493
	LO PR	128	133	135	145	159	131	135	137	147	161	134	137	139	149	163	138	139	141	152	165	142	142	144	154	168
1300	MBh†	40.38	41.39	42.32	45.67	50.46	38.95	39.56	40.43	43.66	48.27	37.40	37.62	38.41	41.50	45.91	35.71	35.72	36.24	39.19	43.39	33.88	33.88	33.91	36.70	40.68
	S/T‡	1.00	0.94	0.75	0.72	0.53	1.00	0.96	0.76	0.73	0.54	1.00	0.98	0.78	0.75	0.54	1.00	1.00	0.80	0.77	0.55	1.00	1.00	0.82	0.79	0.57
	AMPS*	11.92	11.91	11.90	11.86	11.82	13.44	13.43	13.41	13.35	13.28	15.15	15.15	15.13	15.03	14.93	17.13	17.13	17.12	16.99	16.84	19.44	19.44	19.45	19.28	19.08
	HI PR	282	283	284	288	293	325	326	327	331	337	373	373	374	379	385	426	426	426	431	437	484	484	484	488	495
	LO PR	133	136	138	148	162	136	138	140	150	164	139	140	142	152	166	142	142	144	154	168	146	146	146	156	171
1425	MBh†	41.69	42.12	42.99	46.38	51.23	40.19	40.28	41.04	44.31	48.96	38.55	38.55	38.96	42.08	46.53	36.78	36.78	36.72	39.69	43.93	34.86	34.86	34.32	37.13	41.15
	S/T‡	1.00	0.97	0.77	0.74	0.54	1.00	0.99	0.79	0.76	0.55	1.00	1.00	0.80	0.77	0.56	1.00	1.00	0.83	0.80	0.57	1.00	1.00	0.86	0.82	0.58
	AMPS*	12.04	12.04	12.03	11.99	11.96	13.55	13.55	13.54	13.47	13.41	15.26	15.26	15.25	15.16	15.05	17.22	17.22	17.23	17.10	16.96	19.51	19.51	19.56	19.39	19.19
	HI PR	283	284	285	289	294	327	327	328	332	338	375	375	375	380	386	428	428	427	432	438	486	486	485	489	496
	LO PR	137	138	141	151	165	140	140	142	152	166	143	143	144	154	168	147	147	146	156	171	151	151	151	148	159

† Total capacities are net (I.D blower heat subtracted).

* System amps are total of indoor and outdoor amps

‡ S/T are based on 80° F db entering air at the indoor coil. For sensible capacities at other than 80° F db, deduct 835 BTU/h per 1000 cfm of indoor coil air from (MBh x S/T) for each degree below 80° F, or add 835 BTU/h per 1000 cfm of indoor coil air to (MBh x S/T) for each degree above 80° F

†† At TVA rating indoor condition (75° F db/ 63° F wb), All other indoor air temperatures are at 80° F db

ACCESSORIES

ROOF CURBS

Model Number	Height (K) – inches (mm)	Use With Model Size
AXB020CLA	8" (203.2)	24, 30
AXB020CMA	14" (355.6)	
AXB020CHA	24" (609.6)	
AXB030CLA	8" (203.2)	36, 42, 48, 60
AXB030CMA	14" (355.6)	
AXB030CHA	24" (609.6)	

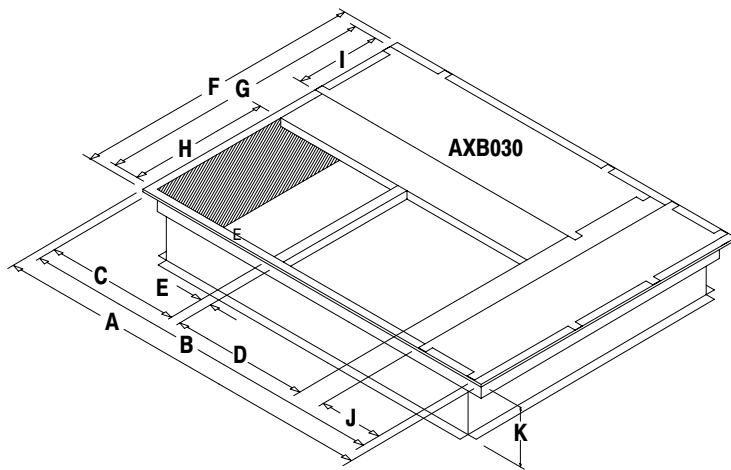
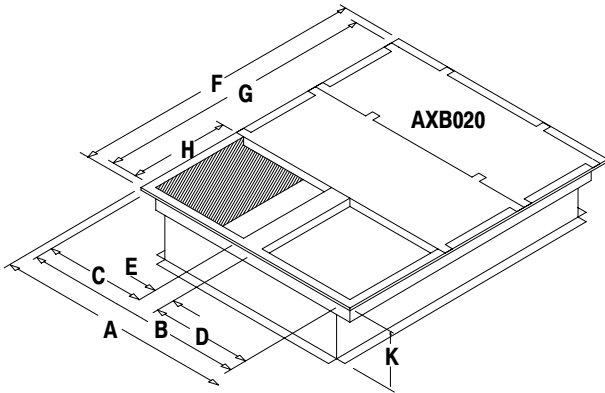

ROOF CURB DIMENSIONS inches (mm)

Model Number	A	B	C	D	E	F	G	H	I	J	K (LA)	K (MA)	K (HA)
AXB020(L,M,H)A	42-3/4 (1086)	39-3/4 (1010)	18 (457)	18 (457)	3-3/4 (95)	42-3/4 (1086)	39-3/4 (1010)	18 (457)	-	-	8 (210)	14 (356)	24 (610)
AXB030(L,M,H)A	67-3/4 (1721)	64-3/4 (1721)	23 (584)	23 (584)	2-1/2 (63.5)	42-3/4 (1086)	39-3/4 (1010)	23 (584)	12 (305)	12 (305)	8 (210)	14 (356)	24 (610)

SQUARE to ROUND TRANSITION inches (mm)

Model Number	Round Size	Use With Roof Curb	Use With Model Size
AXB020CTA	16" (406)	AXB020CLA, AXB020CMA, AXB020CHA	24, 30
AXB030CTA	18" (457)	AXB030CLA, AXB030CMA, AXB030CHA	36, 42, 48, 60

CONCENTRIC GRILLE – FLUSH MOUNT

Model Number	Use With Roof Curb	Use With Model Size
AXB020CFA	AXB020CLA, AXB020CMA, AXB020CHA	24, 30
AXB030CFA	AXB030CLA, AXB030CMA, AXB030CHA	36, 42, 48, 60

CONCENTRIC GRILLE – STEP DOWN

Model Number	Use With Roof Curb	Use With Model Size
AXB020CSA	AXB020CLA, AXB020CMA, AXB020CHA	24, 30
AXB030CSA	AXB030CLA, AXB030CMA, AXB030CHA	36, 42, 48, 60

ACCESSORIES

ECONOMIZERS (ALL FULLY MODULATING)*

Part Number	Application	Motion	Control	Use With Model Size
AXB020HED	Horizontal	Fully Modulating w/ Return Air Damper w/ Relief Damper	Enthalpy	24, 30
AXB030HED				36, 42, 48, 60
AXB020EMD	Downflow			24, 30
AXB030EME				36, 42, 48, 60
AXB020HPE	Horizontal	Fully Modulating w/ Return Air Damper w/ Relief Damper	Dry Bulb Only	24, 30
AXB030HPE				36, 42, 48, 60
AXB020EPE	Downflow			24, 30
AXB030EPF				36, 42, 48, 60

- * Three position economizers no longer available.
 Economizers for model sizes 24 & 30 include Filters and Filter Racks.
 Economizers for model sizes 36, 42, 48, and 60 do NOT include Filters (Filter Racks shipped with unit).

0% - 25% FRESH AIR DAMPERS (use in DOWNFLOW application only) *

Model Number	Control	Use With Model Size
AXB020FAC	Manual	24, 30
AXB030FAC		36, 42, 48, 60
AXB020FMC	Motorized	24, 30
AXB030FMC		36, 42, 48, 60

- * Unit must have internal filters to protect evaporator coil when Fresh Air Damper is installed.
 Model sizes 24 & 30 shipped WITHOUT Filter Racks or Filters.
 Model sizes 36, 42, 48, and 60 shipped WITH Internal Filter Racks, but WITHOUT Filters.

FILTER RACK and FILTER * inches (mm)

Model Number	Application	Filter Location	Filter Size	Use With Model Size
AXB020FKA	Downflow	Internal	18 x 25 x 1 (457 x 635 x 25)	24, 30
AXB020FHC	Horizontal	External	20 x 25 x 1 (508 x 635 x 25)	

- * Model sizes 24, 30 shipped WITHOUT Filter Racks or Filters.
 Model sizes 36, 42, 48, and 60 shipped WITH Internal Filter Racks, but WITHOUT Filters.

LOW AMBIENT CONTROL

Model Number	FAST Part Number	Description	Use With Model Size
ALA14CU0A	n/a	Pressure switch cycles condenser fan	ALL
n/a	1148232	Freeze 'stat, opens 30° F, closes 50° F	ALL

COIL PROTECTION

FAST Part Number	Description	Use With Model Size
1149485	Coil Guard, black, two-piece	24, 30
1068133	Hail Guard, black, two-piece	24, 30
1149486	Coil Guard, black, three-piece	36, 42, 48, 60
1068134	Hail Guard, black, three-piece	36, 42, 48, 60

OUTDOOR THERMOSTAT

Model Number	Description	Use With Model Size
AMF002OTA	2 Stage, Electronic	ALL

UNIT DIMENSIONS

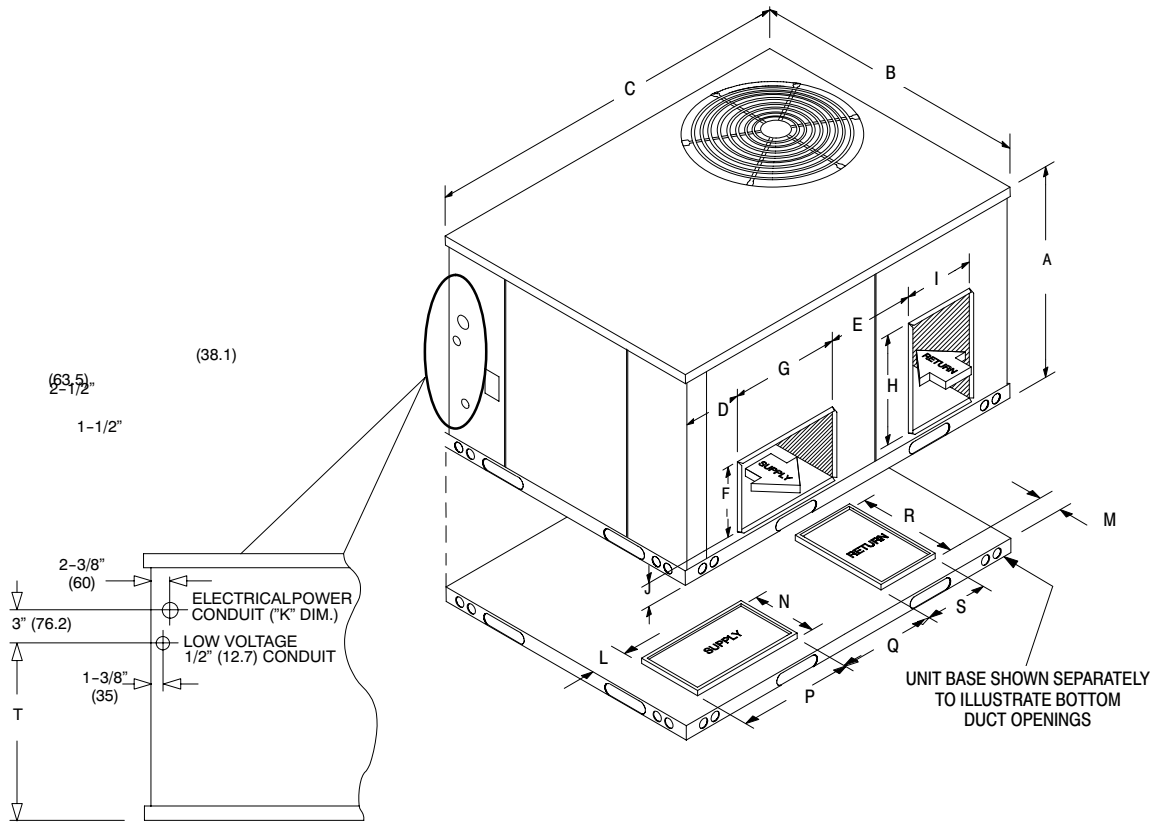

ALL DIMENSIONS IN INCHES

Model Size (Ton)	A	B	C	D	E	F	G	H	I	J	K	L	M	N**	P**	Q	R	S	T	Bottom L x W* Inside Base Rail
2, 2½	32-1/2 (825)	47-3/8 (1203)	47-3/8 (1203)	3-1/8 (79)	11-1/8 (283)	12 (305)	14-1/4 (362)	14-1/4 (362)	12 (305)	4 (102)	3/4 & 1 (19 & 25)	4-1/4 (108)	4-3/8 (111)	14-1/2 (368)	12-1/4 (311)	12-1/8 (308)	14-1/4 (362)	12-1/4 (311)	21-1/2 (546)	43-1/8 x 43-1/8 (1095 x 1095)
3, 3½	36 (914)	47-3/8 (1203)	73 (1854)	4-5/8 (117)	15 (381)	12 (305)	18-3/4 (476)	18-3/4 (476)	12 (305)	4 (102)	1 & 1-1/4 (25 & 32)	4-1/4 (108)	5-1/4 (133)	12-1/4 (311)	19 (483)	15 (381)	19 (483)	12-1/4 (311)	25-1/16 (637)	68-3/4 x 43-1/8 (1746 x 1095)
4, 5	42 (1067)	47-3/8 (1203)	73 (1854)	4-5/8 (117)	15 (381)	12 (305)	18-3/4 (476)	18-3/4 (476)	12 (305)	4 (102)	1 & 1-1/4 (25 & 32)	4-1/4 (108)	5-1/4 (133)	12-1/4 (311)	19 (483)	15 (381)	19 (483)	12-1/4 (311)	31-1/16 (789)	68-3/4 x 43-1/8 (1746 x 1095)

** The supply opening in the drawing is shown for the orientation in the 3 to 5 Ton units. The opening for the 2 to 2-1/2 Ton units is rotated 90°, so the N and P dimensions are correct.

MODEL NUMBER IDENTIFICATION GUIDE

Product Family	SEER	Nominal Cooling Capacity BTU/h	Heating Input BTU/h	Voltage	Option Code	Design Code	Eng. Rev. Code
PAX - Package Air Conditioner, R-410A	4 = 14	24 = 24,000	000 = N/A (electric heaters available as accessories)	K = 208/230-1-60	00 = N/A	A	1
		30 = 30,000					
		36 = 36,000					
		42 = 42,000					
		48 = 48,000					
60 = 60,000							
Example: PAX	4	24	000	K	00	A	1

GUIDE SPECIFICATIONS

CABINET

The cabinet is made of G-90 galvanized steel, phosphate coated with a tough acrylic finish coat for long lasting weatherproof construction. The base rails are 18 gauge steel with fork lift slots and holes provided for lifting shackles. The unit is designed with convertible airflow for either horizontal or downflow applications with conversion accomplished by relocating two panels. Indoor blower compartment interior cabinet surfaces are insulated with a minimum 3/4" thick, flexible glass fiber insulation, coated on the air side. Aluminum foil faced glass fiber insulation is used in the furnace compartment.

COOLING SECTION

The unit is factory charged and operationally ready upon delivery. The unit refrigerant circuit has a high efficiency fully hermetic compressor with internal overload protection, and copper tube / aluminum fin evaporator and condenser coils. The unit is designed for cooling operation to 40° F and will be capable of being wired for field installed economizer type accessories.

COILS

The evaporator and condenser coils are fabricated with aluminum fins mechanically bonded to copper tubing. Both coils are pressure tested prior to assembly into the unit and electronically leak tested after assembly into the unit.

CONDENSER FAN

The unit has a single direct-drive propeller-fan / motor assembly. The assembly is mounted directly to a vertical-discharge grille that is easily removed for service. Motors are 1100 RPM with sleeve or ball bearings and internal overload protection.

EVAPORATOR BLOWER

All units have a direct-drive high efficiency brushless DC evaporator blower motor as a standard. The direct-drive evaporator blower motor has sleeve bearings and internal overload protection.

INSTALLATION CLEARANCES

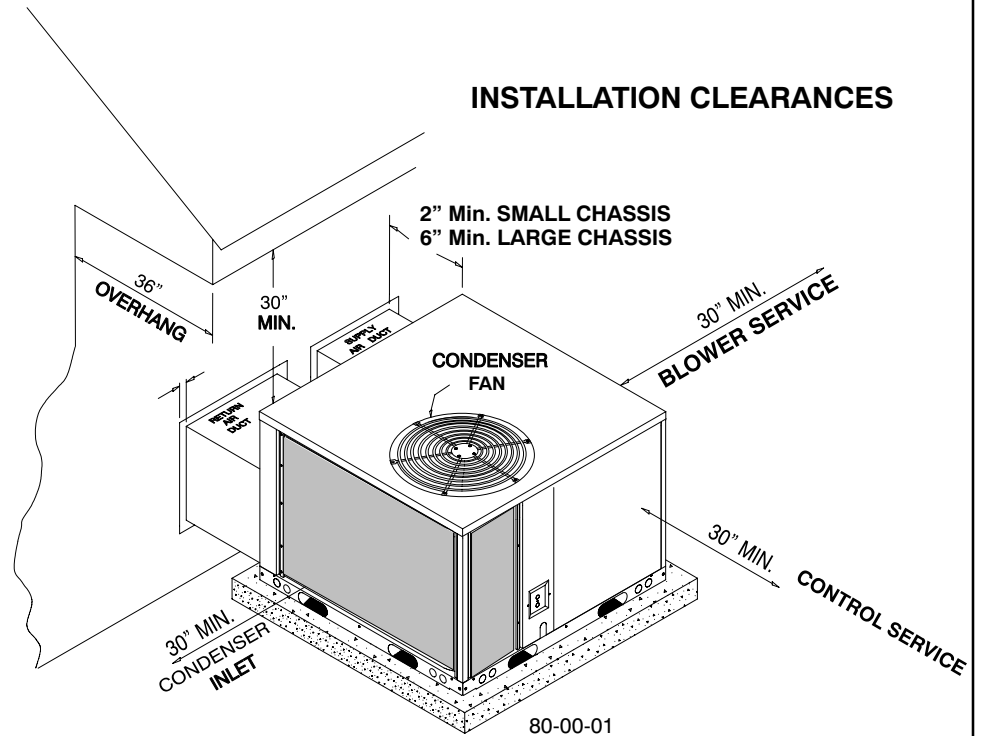

RIGGING DETAILS

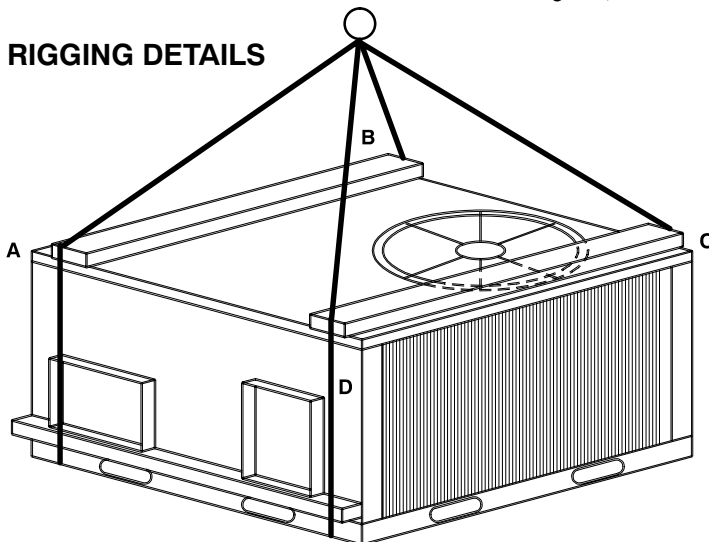

CORNER WEIGHTS (LBS)

MODEL	A	B	C	D	OPERATING WEIGHT TOTAL
PAX424	78	109	118	87	392
PAX430	78	109	118	87	392
PAX436	87	119	127	90	424
PAX442	113	155	165	117	550
PAX448	130	154	166	131	581
PAX460	125	168	176	138	606