

**SMALL PACKAGED PRODUCT (3 - 5 TONS)
VERTICAL ECONOMIZER ACCESSORY
INCLUDING 3 TON 14 SEER HP & DUAL FUEL MODELS**

**Part Number:
CPECOMZR008A00 & CPECOMZR009A00**

Installation Instructions

Read these instructions completely before attempting to install the Vertical Economizer Accessory.

CONTENTS

SAFETY CONSIDERATIONS 1
GENERAL 1,2
ACCESSORIES LIST 2
INSTALLATION 2-6
CONFIGURATION 6-10
ECONOMIZER CONTROL MODES 6
OPERATION 10
SEQUENCE OF OPERATION 10
PERFORMANCE DATA 11
TROUBLESHOOTING 12-13
WIRING DIAGRAMS 14-15

SAFETY CONSIDERATIONS

Installation and servicing of air-conditioning equipment can be hazardous due to system pressure and electrical components. Only trained and qualified service personnel should install, repair, or service air-conditioning equipment.

Untrained personnel can perform the basic maintenance functions of replacing filters. All other operations should be performed by trained service personnel. When working on air-conditioning equipment, observe precautions in the literature, tags, and labels attached to the unit, and other safety precautions that may apply.



Recognize safety information. This is the safety-alert symbol. When you see this symbol on the unit and in instructions or manuals, be alert to the potential for personal injury. Understand these signal words; DANGER, WARNING, and CAUTION. These words are used with the safety-alert symbol. DANGER identifies the most serious hazards which will result in severe personal injury or death. WARNING signifies hazards which could result in personal injury or death. CAUTION is used to identify unsafe practices which may result in minor personal injury or product and property damage. NOTE is used to highlight suggestions which will result in enhanced installation, reliability, or operation.

Follow all safety codes. Wear safety glasses and work gloves. Have a fire extinguisher available.

⚠ WARNING

ELECTRICAL SHOCK HAZARD

Electrical shock can cause injury or death. Disconnect power supply and install lockout tag before attempting to install accessory.

⚠ CAUTION

UNIT PERFORMANCE AND COMPONENT HAZARD

Failure to follow this caution may result in unit damage. For cooling operation, the recommended airflow is 350 to 450 cfm for each 12,000 Btuh of rated cooling capacity. For heating operation, the airflow must produce a temperature rise that falls within the range stamped on the unit rating plate.

GENERAL

Economizers are recommended for only commercial packaged products that have X13 high static motors. The Economizer system utilizes the latest technology available for integrating the use of free cooling with mechanical cooling for rooftop units. The solid state control system optimizes energy consumption, zone comfort, and equipment cycling by operating the compressors when the outdoor-air temperature is too warm, integrating the compressor with outdoor air when free cooling is available, and locking out the compressor when outdoor-air temperature is too cold. Demand ventilation is supported.

The Economizer system utilizes gear-drive technology with a direct-mount spring return actuator that will close upon loss of power. The Economizer system comes standard with an outdoor air temperature sensor, a supply air temperature sensor, and low temperature compressor lockout switch. Return-air temperature, indoor enthalpy, and outdoor enthalpy sensors are available for field installation. Field-installed CO₂ sensors are available.

Barometric relief dampers provide natural building pressurization control. Barometric relief dampers are built into the design and are standard. See Table 1 for package contents. See Table 2 for sensor usage.

Table 1 - Filter Sizes

Economizer PN	Filter QTY and Sizes
CPECOMZR011A00	(1) 14x24 (355.6x609.6 mm) (1) 16x24 (406.4x609.6 mm)
CPECOMZR012A00	(1) 16x24 (406.4x609.6 mm) (1) 18x24 (457.2x609.6 mm)

Package Contents

PACKAGE NO.	QTY	CONTENTS
CPECOMZR011A00 & CPECOMZR012A00	1	Hood Top and Sides
	1	Hood Divider
	1	Aluminum Filter
	11	#10 Self-Drilling Screws w/ Washers
	4	#10 x 1/2" Blunt End Screws
	1	#10 x 1" Self Drilling Screw
	1	Economizer Assembly
	1	Supply Air Temperature Sensor With Bracket
	2	1" (25.4mm) Throw Away Filters
	1	Top Filter Rack
	1	Bottom Filter Rack
	1	Replacement Return Chamber Panel
	1	Compressor Cover Panel
	1	Extension Harness With Plug
	2	Wiring Dia. Labels

Table 2 - Economizer Sensor Usage			
APPLICATION	ECONOMIZER WITH OUTDOOR AIR DRY BULB SENSOR		
	Accessories Required		
Outdoor Air Dry Bulb	None. The outdoor air dry bulb sensor is factory installed.		
Differential Dry Bulb	CRTEMPSN002A00*		
Single Enthalpy	HH57AC078		
Differential Enthalpy	HH57AC078 and CRENTDIF004A00*		
CO2 for DCV Control Using a Wall-Mounted CO2 Sensor	33ZCSENCO2 or CGCDXSEN004A00		
CO2 for DCV Control Using a Duct-Mounted CO2 Sensor	33ZCSENCO2 or CGCDXSEN004A00† and 33ZCASPCO2 or CGCDXASP00100**		CRCBDIOX005A00††

*CRENTDIF004A00 and CRTEMPSN002A00 accessories are used on many different base units. As such, these kits may contain parts that will not be needed for installation.
 †33ZCSENCO2 and CGCDXSEN004A00 are accessory CO2 sensors.
 **33ZCASPCO2 and CGCDXASP00100 are accessory aspirator boxes required for duct-mounted applications.
 ††CRCBDIOX005A00 is an accessory that contains both 33ZCSENCO2 and 33ZVASPCO2 accessories.

ACCESSORIES LIST

The economizer has several field-installed accessories available to optimize performance. Refer to Table 3 for authorized parts.

Table 3 - Economizer Field-Installed Accessories	
DESCRIPTION	PART NUMBER
Return Air Temperature Sensor	CRTEMPSN002A00
Outdoor Air Enthalpy Sensor	HH57AC078
Indoor Air Enthalpy Sensor	CRENTDIF004A00
Return Air CO2 Sensor (4-20 mA)	CRCBDIOX005A00
CO2 Room Sensor (4-20 mA)	33ZCASPCO2 or CGCDXSEN004A00
Aspirator Box for Duct Mount CO2 Sensor (4-20 mA)	33ZCASPCO2 or CGCDXASP001A00
Space Temperature and CO2 Room Sensor with Override (4-20mA)	33ZCT55CO2
Space Temperature and CO2 Room Sensor with Override and Set Point (4-20mA)	33ZCT56CO2
Heat Pump Relay Package	CPRLYKIT001A00

INSTALLATION

Economizer - See Fig. 2 for Economizer component locations. To install the vertical Economizer perform the following procedure:

1. Turn off unit power supply and install lockout tag.

WARNING

ELECTRICAL SHOCK HAZARD

Failure to follow this warning could result in personal injury or death.

Before installing or servicing system, always turn off main power to system and tag. There may be more than one disconnect switch. Turn off accessory heater power switch if applicable.

2. Remove the side panel shipped on the HVAC unit. See Fig. 3.
3. Make sure the panel covering the bottom return air duct opening has been removed, allowing for unobstructed vertical return.

4. Install the top filter rack in the HVAC unit next to the indoor coil. Lift rack to the very top of the chamber, and screw into both the left and right side of the coil FRAME, using #10 x 1/2" Blunt End screws. Be careful not to insert screws where coil damage could occur. If using 2" (50.8mm) filters, the filter spacer must be removed. See Fig. 1.

5. Install the bottom filter in the HVAC unit next to the indoor coil. Filter rack will rest on the HVAC base and screw into both the left and right sides of coil FRAME, using #10 x 1/2" Blunt End Screws. Be careful not to insert screws where coil damage could occur.

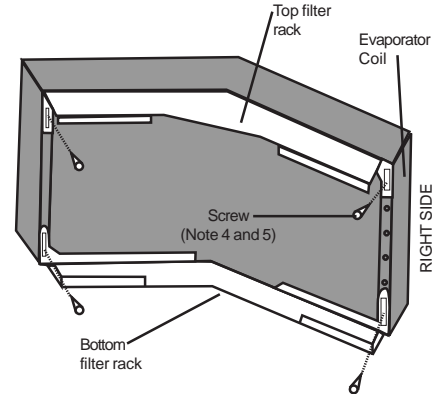

Fig. 1A - Filter Rack Installation (Bent Coil)

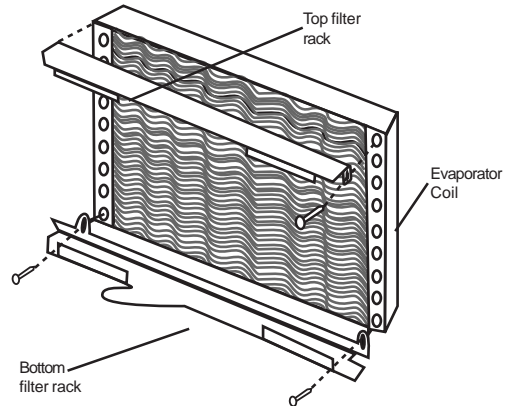

Fig. 1B - Filter Rack Installation (Straight Coil)

6. Most new 3 Phase HVAC units will have an economizer plug in the return air chamber, which runs back to the control box. If the unit has the economizer harness / plug, first remove the jumper plug from the end of the harness to allow the plug from the economizer to be connected.

NOTE: The jumper plug should be saved for future use in the event that the economizer is removed from the unit. The jumper plug is not needed as long as the economizer is installed.

In the event that your HVAC unit does not have a factory installed harness for the economizer, the extension harness shipped with the economizer must be installed in the unit. Route the extension harness through the HVAC unit as shown in Fig. 9. The plug end of the harness extension will connect to the economizer plug in the return chamber and the other end will be routed to and connect in the control box.

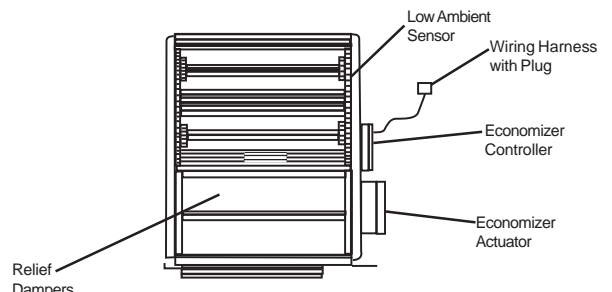

Fig. 2 - Component Locations

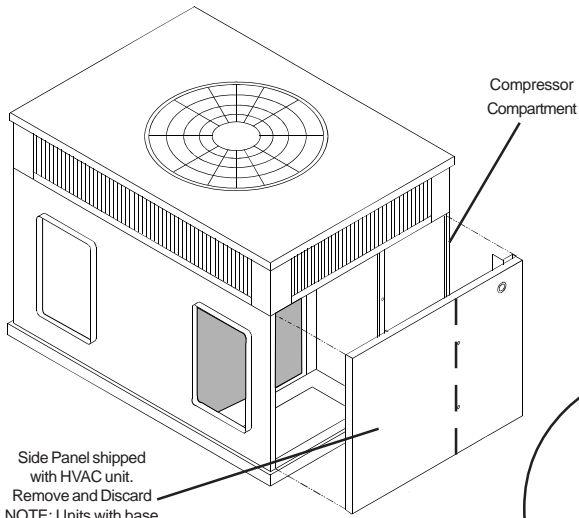

Fig. 3 - Panel Removal

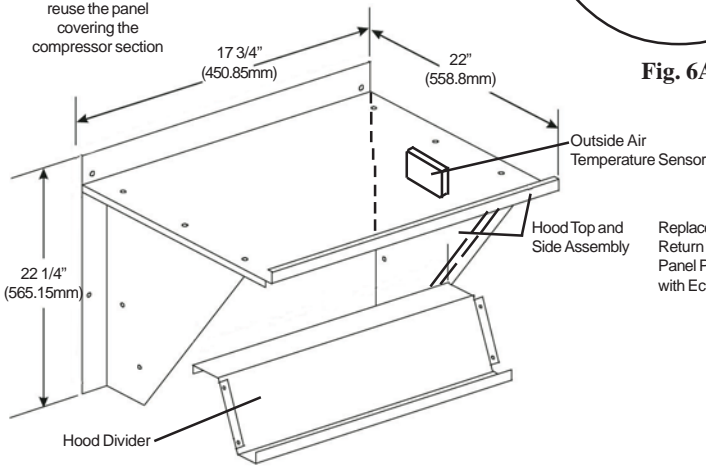

Fig. 4 - Hood Assembly

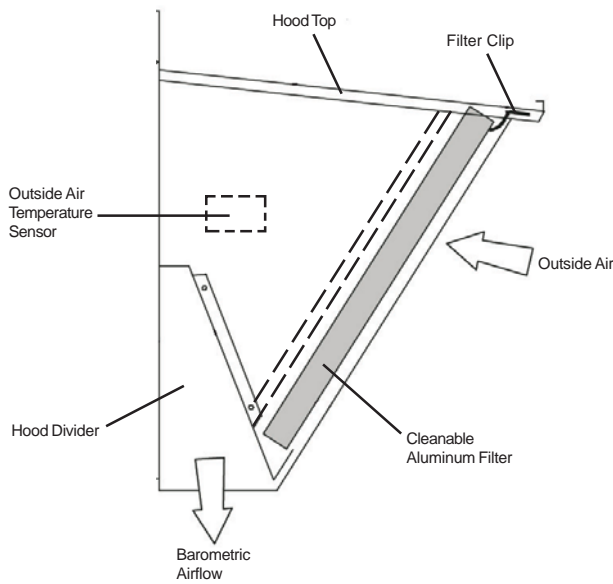

Fig. 5 - Filter Installation

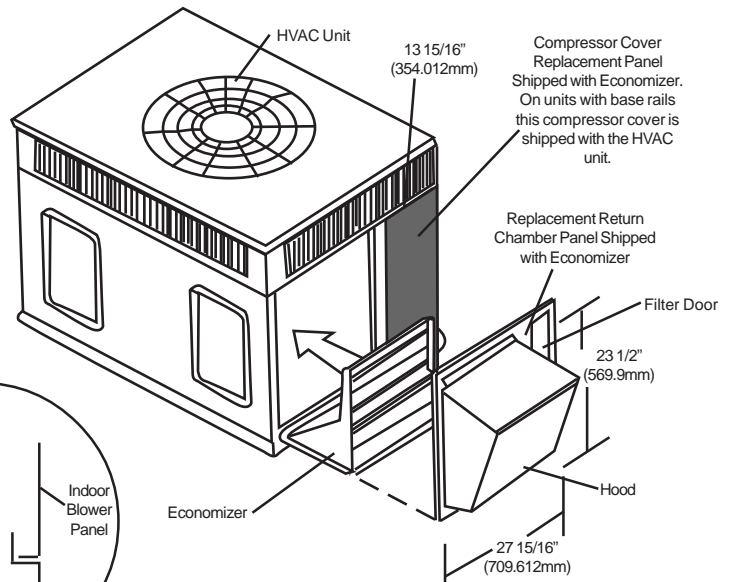

Fig. 6 - Economizer Installation

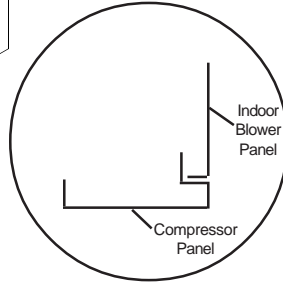

Fig. 6A

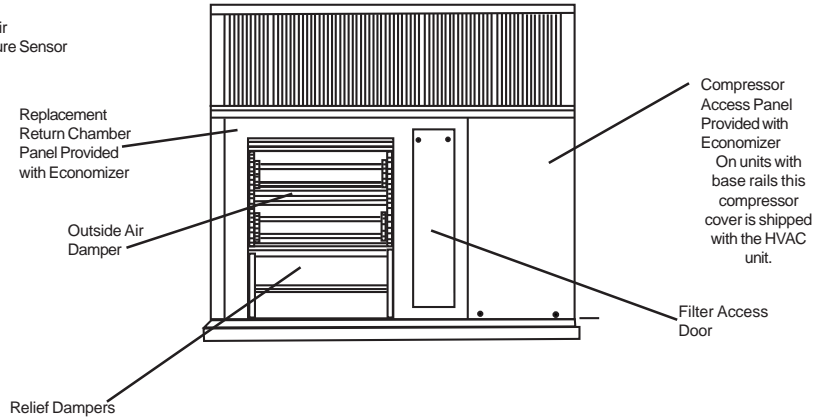

Fig. 7 - Economizer Installed in HVAC Unit

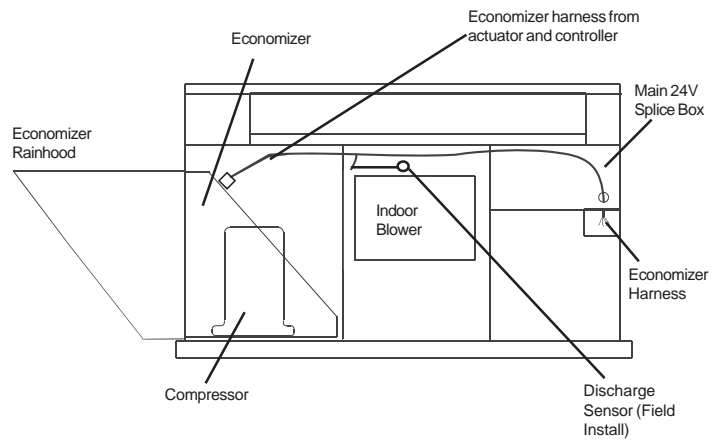
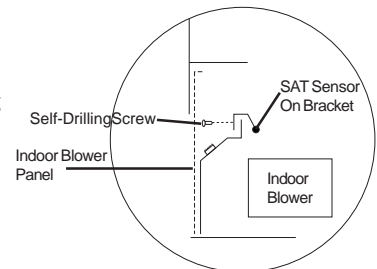

Fig. 8 - Routing Harness Extension and Mounting SAT Sensor

Fig. 8A - SAT Mounting For Units With Upper Block Off Panel



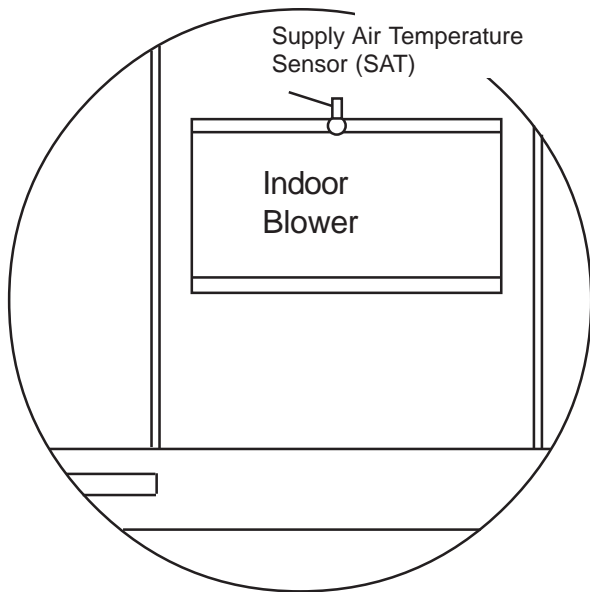

Fig. 8B - SAT Location For Units Without Block Off Panel

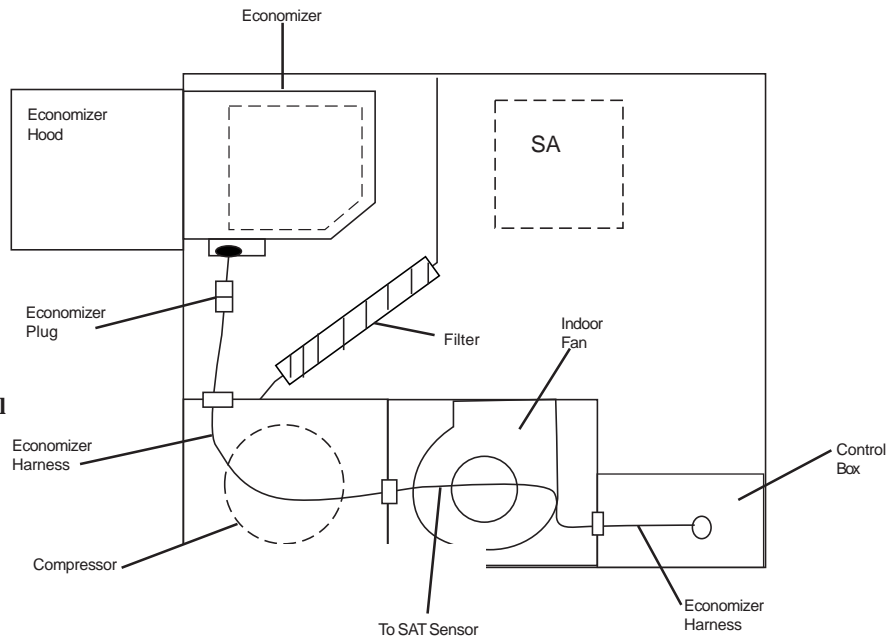

Fig. 9 - Routing Harness (Top View)

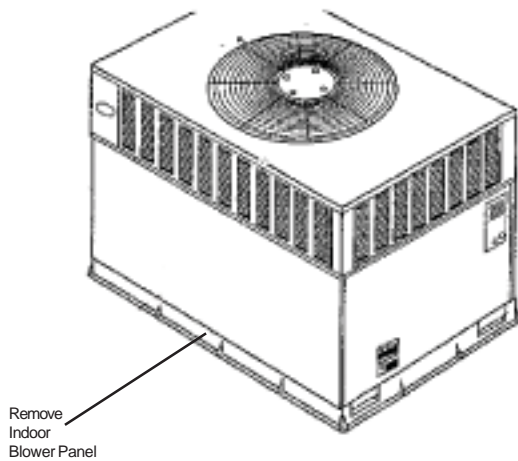

Fig. 10 - Indoor Blower Panel

7. Remove the panel on the HVAC unit covering the indoor blower. The (provided) Supply Air Temperature (SAT) sensor, which looks like an eyelet terminal, must be installed in the blower section. Attach the (2) pink wires from the economizer harness (or extension harness) to the SAT.

The SAT sensor is shipped attached to a small bracket. If the HVAC unit has an upper blank off panel, attach the sensor / bracket as shown in Fig. 8A using a self-drilling screw. If the unit does not have an upper block off panel, remove the bracket from the SAT and screw the SAT to the side of the indoor blower, using a self-drilling screw, as shown in Fig. 8B.

8. Replace the panel covering the indoor air blower.

NOTE: For heat pump units, an additional relay package, Factory kit part number CPRLYKIT001A00, or field provided relays must be installed in the blower section. See heat pump diagram for details.

Installation Of Heat Pump Relays

When this economizer is used on a heat pump HVAC units, relays must be added for proper operation.

The relays, which are shown on the attached diagrams, can be field supplied, or relay kit CPRLYKIT001A00 can be ordered. Field provided relays must be:

- SPDT, one pole normally open and one normally closed. Same polarity.
- Minimum 124 VA inrush.

Acceptable relays include:

- Honeywell: R822B117.
- Honeywell: R422B1124.
- White Rodgers: 91-103001-13002.
- White Rodgers: 91-102006-13302.

Relay Installation:

A. If the optional relay package CPRLYKIT001A00 is used, it will mount underneath the indoor blower as shown in Fig. 11 & 12. Follow instructions sent with the package.

B. If relays are field provided and installed, they can be mounted above the upper blank off panel, as shown in Fig. 11, which will eliminate the need for harness extensions. Use caution to ensure screws to do not interfere with blower operation, Blunt end screws are recommended.

C. If no upper block off panel is present mount relays on compressor partition below indoor blower on left as shown in Fig. 11.

D. Wire the relays per diagrams in this instruction.

Fig. 11

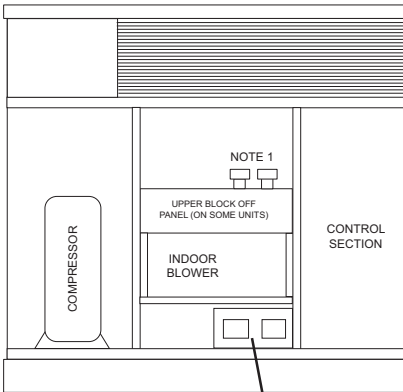

NOTE 1: Field provided relays can be mounted on top of upper block off panel, if applicable

Location for heat pump relay package number CPRLYKIT001A00.

Fig. 12

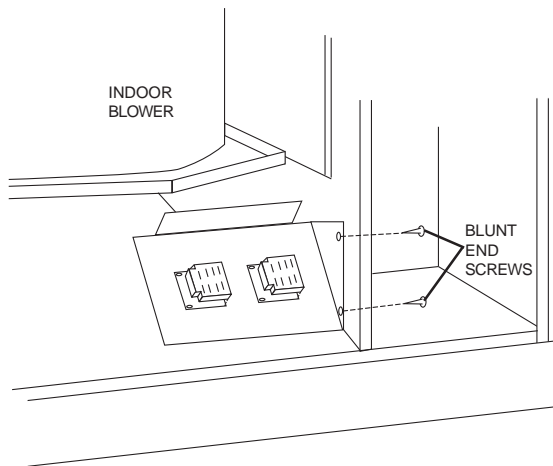

9. Install the compressor access panel provided with the economizer. Screw to HVAC unit per Fig. 6 and 7. NOTE: Units with base rails will have compressor panel shipped with unit.

10. Install the economizer assembly into the return air chamber, making sure the economizer completely covers the bottom return air opening. See Fig. 6. Remove the red shipping tape holding the relief dampers closed.

NOTE: The hole in the center of the bottom of the economizer will line up with the mating hole in the HVAC base - however do not insert screw yet.

11. Install the replacement return chamber panel over the economizer assembly and underneath the drip flange on the HVAC unit. Line up the bottom center hole on the panel with the hole in the bottom of the economizer and the mating hole in the base of the HVAC unit. Insert screw, which will hold all parts in place. Insert screws on bottom, left, and right of panel and on panel right side as well. See Fig. 6.

12. Remove the hood parts from the economizer package. Assemble as shown in Fig. 4 by screwing together with provided #10 sheet metal screws.

13. Caulk or gasket the back side of the hood mating flanges. Install assembled hood over the economizer opening in the replacement return chamber panel. Screw in place through pre-punched holes. Make sure all seams are watertight.

14. The outside air temperature sensor (OAT) is factory mounted to the side of the hood, see Fig. 4. Connect the sensor to the economizer harness per wiring diagram.

15. Open the filter clips on the inside of the hood top. Insert the aluminum filter into the hood and close the clips to hold in place. See Fig. 5.

16. Remove the filter access panel (IMPORTANT: On the CPECOMZR009A00 filter rack, the 18 x 24 (457.2mm x 609.6mm) filter must be installed through the filter access door first. Then install the 16 x 24 (406.4mm x 609.6mm) filter.) and install disposable filters in filter rack.

NOTE: The economizer control settings and the filters are accessible through the filter access door.

17. Through the filter access door, adjust the settings on the economizer controller. Review the settings in the Operation section:

- (1) The standard economizer controller has a factory setting of “C” for the outdoor air temperature changeover and 55°F (12.8°C) for the supply air (mixed air) temperature sensor. The outdoor air temperature sensor setting can be adjusted at the controller.
- (2) The low ambient compressor lockout switch setting is fixed at 42°F (5.6°C).
- (3) The minimum position for the outdoor air damper can be configured at the controller.
- (4) Settings for the optional return air temperature sensor, outdoor enthalpy sensor, indoor enthalpy sensor, and CO₂ sensor can also be configured at the controller.

18. Replace the filter access panel. Screw in place.

19. Install all economizer accessories then power HVAC unit and test cycle economizer.

CONFIGURATION

Economizer Standard Sensors

OUTDOOR AIR TEMPERATURE (OAT) SENSOR— The outdoor air temperature sensor (HH57AC074) is a 10 to 20mA device used to measure the outdoor-air temperature. The outdoor-air temperature is used to determine when the Economizer can be used for free cooling. The operating range of temperature measurement is 40° to 100°F (4.4° to 37.8°C).

SUPPLY AIR TEMPERATURE (SAT) SENSOR—The supply air temperature sensor is a 3 K thermistor located at the inlet of the indoor fan. See Fig. 8 and 9. This sensor is field installed. The operating range of temperature measurement is 0° to 158°F (-17.8° to 70°C). See Table 4 for sensor temperature/resistance values.

The temperature sensor looks like an eyelet terminal with wires running to it. The sensor is located in the “crimp end” and is sealed from moisture.

LOW TEMPERATURE COMPRESSOR LOCKOUT SWITCH

SWITCH—The Economizer is equipped with a low ambient temperature lockout switch located in the outdoor airstream which is used to lock out the compressors below a 42°F (5.6°C) ambient temperature.

TEMPERATURE (F)	CELSIUS (C)	RESISTANCE (ohms)
-22	-30	53,010
-4	-20	29,091
14	-10	16,590
32	0	9,795
50	10	5,970
68	20	3,747
77	25	3,000
86	30	2,416
104	40	1,597
122	50	1,080
140	60	746
158	70	525

Economizer Control Modes— Determine the Economizer control mode before set up of the control. Some modes of operation may require different sensors. Refer to Table 3. The Economizer is supplied from the factory with a supply air temperature sensor, a low temperature compressor lockout switch, and an outdoor air temperature sensor. This allows for operation of the Economizer with outdoor air dry bulb changeover control. Additional accessories can be added to allow for different types of changeover control and operation of the Economizer and unit.

OUTDOOR DRY BULB CHANGEOVER— The standard controller is shipped from the factory configured for outdoor dry bulb changeover control. The outdoor air and supply air temperature sensors are included as standard.

For this control mode, the outdoor temperature is compared to an adjustable set point selected on the control. If the outdoor-air temperature is above the set point, the Economizer will adjust the outdoor air dampers to minimum position. If the outdoor-air temperature is below the set point, the position of the outdoor-air dampers will be controlled to provide free cooling using outdoor air. When in this mode, the LED next to the free cooling set point potentiometer will be on. The changeover temperature set point is controlled by the free cooling set point potentiometer located on the control. See Fig. 13. The scale on the potentiometer is A, B, C, and D. See Fig. 14 for the corresponding temperature changeover values.

DIFFERENTIAL DRY BULB CONTROL— For differential dry bulb control the standard outdoor dry bulb sensor is used in conjunction with an additional accessory return air sensor (part number CRTEMPSN002A00). The accessory sensor must be mounted in the return airstream. See Fig. 15.

In this mode of operation, the outdoor-air temperature is compared to the return-air temperature and the lower temperature airstream is used for cooling. When using this mode of changeover control, turn the free cooling/enthalpy set point potentiometer fully clockwise to the D setting. See Fig. 14.

OUTDOOR ENTHALPY CHANGEOVER—For enthalpy control, accessory enthalpy sensor (part number HH57AC078) is required. Replace the standard outdoor dry bulb temperature sensor with the accessory enthalpy sensor in the same mounting location.

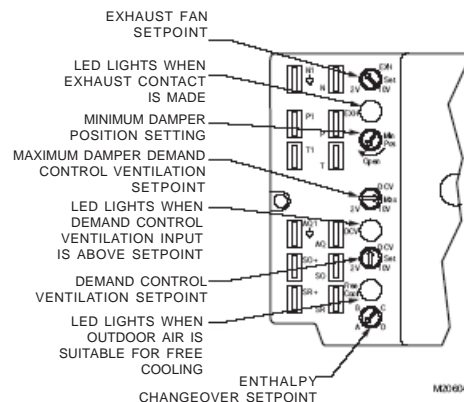

Fig. 13 - Economizer Controller Potentiometer and LED Locations

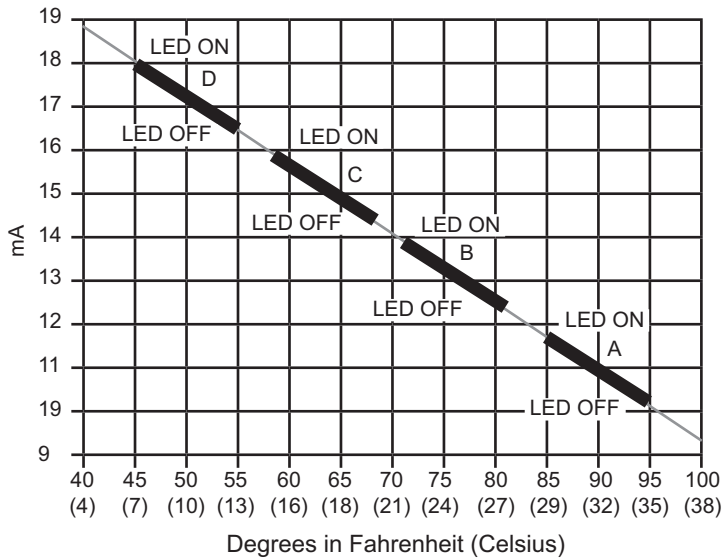

Fig. 14 - Outdoor Air Temperature Changeover Set Points

INDOOR AIR QUALITY (IAQ) SENSOR INPUT —The IAQ input can be used for demand control ventilation control based on the level of CO₂ measured in the space or return air duct.

Mount the accessory IAQ sensor according to manufacturer specifications. The IAQ sensor should be wired to the AQ and AQ1 terminals of the controller. Adjust the DCV potentiometers to correspond to the DCV voltage output of the indoor air quality sensor at the user-determined set point. See Fig. 18.

If a separate field-supplied transformer is used to power the IAQ sensor, the sensor must not be grounded or the Economizer control board will be damaged.

When the outdoor air enthalpy rises above the outdoor enthalpy changeover set point, the outdoor-air damper moves to its minimum position. The outdoor enthalpy changeover set point is set with the outdoor enthalpy set point potentiometer on the Economizer controller. The set points are A, B, C, and D. See Fig. 14. The factory-installed 620-ohm jumper must be in place across terminals SR and SR+ on the Economizer controller. See Wiring Diagram Page 14 & 15.

DIFFERENTIAL ENTHALPY CONTROL — For differential enthalpy control, the Economizer controller uses two enthalpy sensors (HH57AC078 and CRENTDIF004A00), one in the outside air and one in the return airstream. The Economizer controller compares the outdoor air enthalpy to the return air enthalpy to determine Economizer use. The controller selects the lower enthalpy air (return or outdoor) for cooling. For example, when the outdoor air has a lower enthalpy than the return air and is below the set point, the Economizer opens to bring in outdoor air for free cooling.

Replace the standard outside air dry bulb temperature sensor with the accessory enthalpy sensor in the same mounting location. Mount the return air enthalpy sensor in the return air duct. See Fig. 15. When using this mode of changeover control, turn the enthalpy set point potentiometer fully clockwise to the D setting.

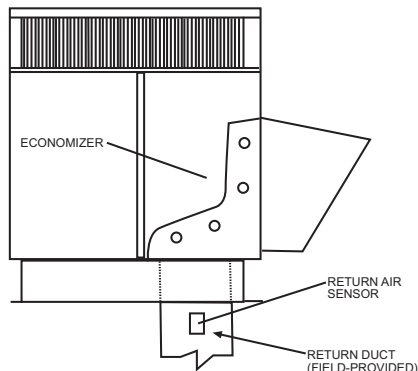

Fig. 15 - Return Air Temperature or Enthalpy Sensor Mounting Location

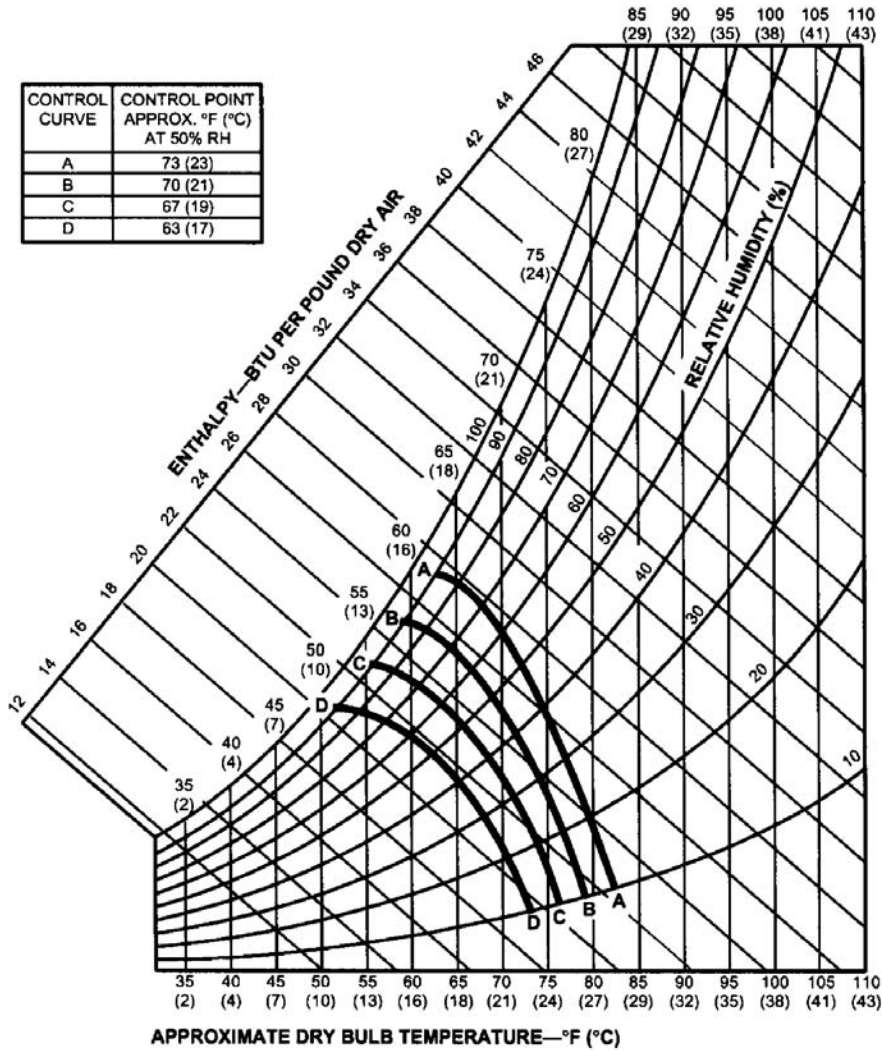

Fig. 16 - Enthalpy Changeover Setpoints

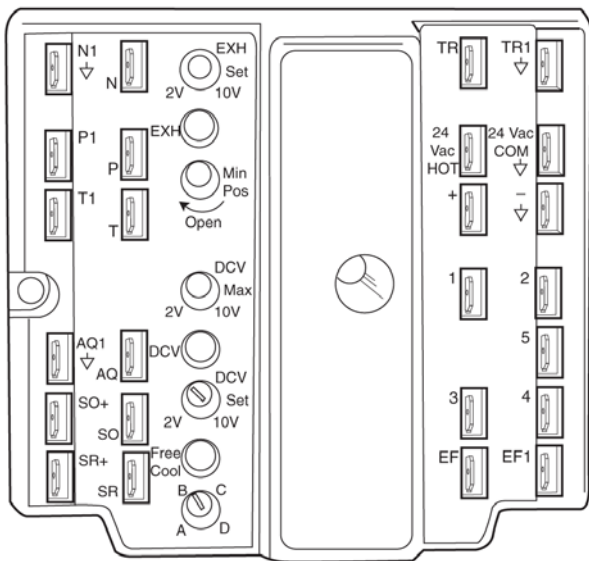

Fig. 17 - Economizer Controller

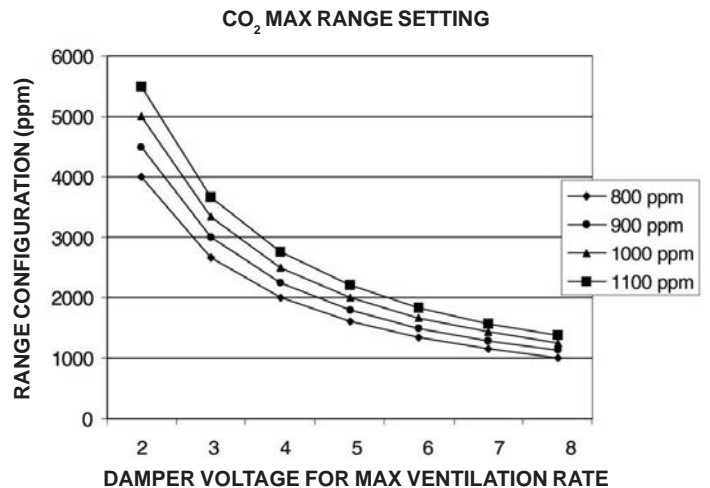

Fig. 18 - CO₂ Sensor Maximum Range Setting

EXHAUST SET POINT ADJUSTMENT—The exhaust set point will determine when the exhaust fan runs based on damper position (if power exhaust is installed). The set point is modified with the Exhaust Fan Set Point (EXH SET) potentiometer. See Page 14 & 15 Wiring Diagram. The set point represents the damper position above which the exhaust fans will be turned on. When there is a call for exhaust, the Economizer controller provides a 45 ± 15 second delay before exhaust fan activation to allow the dampers to open. This delay allows the damper to reach the appropriate position to avoid unnecessary fan overload.

MINIMUM POSITION CONTROL — There is a minimum damper position potentiometer on the Economizer controller. See Fig. 13 and Wiring Diagram Page 14 & 15. The minimum damper position maintains the minimum airflow into the building during the occupied period.

When using demand ventilation, the minimum damper position represents the minimum ventilation position for VOC (volatile organic compound) ventilation requirements. The maximum demand ventilation position is used for fully occupied ventilation.

When demand ventilation control is not being used, the minimum position potentiometer should be used to set the occupied ventilation position. The maximum demand ventilation position should be turned fully clockwise.

Adjust the minimum position potentiometer to allow the minimum amount of outdoor air, as required by local codes, to enter the building. Make minimum position adjustments with at least 10°F (12.2°C) temperature difference between the outdoor and return-air temperatures.

To determine the minimum position setting, perform the following procedure:

1. Calculate the appropriate mixed air temperature using the following formula:

$$(T_o \times OA/100) + (T_r \times RA/100) = T_m$$

T_o = Outdoor-Air Temperature

OA = Percent of Outdoor Air

T_r = Return-Air Temperature

RA = Percent of Return Air

T_m = Mixed-Air Temperature

As an example, if local codes require 10% outdoor air during occupied conditions, outdoor-air temperature is 60°F (15.6°C), and return-air temperature is 75°F (23.9°C).

$$(60 \times .10) + (75 \times .90) = 73.5^\circ\text{F} (23.1^\circ\text{C})$$

2. Disconnect the supply air sensor from terminals T and T1.
3. Ensure that the factory-installed jumper is in place across terminals P and P1. If remote damper positioning is being used, make sure that the terminals are wired according to Fig. 9 and that the minimum position potentiometer is turned fully clockwise.
4. Connect 24 vac across terminals TR and TR1.
5. Carefully adjust the minimum position potentiometer until the measured mixed-air temperature matches the calculated value.
6. Reconnect the supply air sensor to terminals T and T1.

Remote control of the Economizer damper is desirable when requiring additional temporary ventilation. If a field-supplied remote potentiometer (Honeywell part number S963B1128) is wired to the Economizer controller, the minimum position of the damper can be controlled from a remote location.

To control the minimum damper position remotely, remove the factory-installed jumper on the P and P1 terminals on the Economizer controller. Wire the field-supplied potentiometer to the P and P1 terminals on the Economizer controller. See Wiring Diagram Page 14 & 15.

DAMPER MOVEMENT — Damper movement from full open to full closed (or vice versa) takes 2 1/2 minutes.

THERMOSTATS — The Economizer control works with conventional thermostats that have a Y1 (cool stage 1), Y2 (cool stage 2), W1 (heat stage 1), W2 (heat stage 2), and G (fan). The Economizer control does not support space temperature sensors. Connections are made at the thermostat terminal connection board located in the main control box.

OCCUPANCY CONTROL — The factory default configuration for the Economizer control is occupied mode. Occupied status is provided by the black jumper from terminal TR to terminal N. When unoccupied mode is desired, install a field supplied timeclock function in place of the jumper between TR and N. See Page 14 & 15 Wiring Diagram. When the timeclock contacts are closed, the Economizer control will be in occupied mode. When the timeclock contacts are open (removing the 24-v signal from terminal N), the Economizer will be in unoccupied mode.

DEMAND CONTROLLED VENTILATION (DCV)—When using the Economizer for demand controlled ventilation, there are some equipment selection criteria which should be considered. When selecting the heat capacity and cool capacity of the equipment, the maximum ventilation rate must be evaluated for design conditions. The maximum damper position must be calculated to provide the desired fresh air.

Typically the maximum ventilation rate will be about 5 to 10% more than the typical cfm required per person, using normal outside air design criteria.

An exponential anticipatory strategy should be taken with the following conditions: a zone with a large area, varied occupancy, and equipment that cannot exceed the required ventilation rate at design conditions.

Exceeding the required ventilation rate means the equipment can condition air at a maximum ventilation rate that is greater than the required ventilation rate for maximum occupancy. An exponential-anticipatory strategy will cause the fresh air supplied to increase as the room CO₂ level increases even though the CO₂ set point has not been reached. By the time the CO₂ level reaches the set point, the damper will be at maximum ventilation and should maintain the set point.

In order to have the CO₂ sensor control the economizer damper in this manner, first determine the damper voltage output for minimum or base ventilation. Base ventilation is the ventilation required to remove contaminants during unoccupied periods. The following equation may be used to determine the percent of outside-air entering the building for a given damper position. For best results there should be at least a 10 degree F (12.2°C) difference in outside and return-air temperatures.

$$(T_o \times OA/100) + (T_r \times RA/100) = T_m$$

T_o = Outdoor-Air Temperature

OA = Percent of Outdoor Air

T_r = Return-Air Temperature

RA = Percent of Return Air

T_m = Mixed-Air Temperature

Once base ventilation has been determined, set the minimum damper position potentiometer to the correct position.

The same equation can be used to determine the occupied or maximum ventilation rate to the building. For example, an output of 3.6 volts to the actuator provides a base ventilation rate of 5% and an output of 6.7 volts provides the maximum ventilation rate of 20% (or base plus 15 cfm per person). Use Fig. 18 to determine the maximum setting of the CO₂ sensor. For example, a 1100 ppm set point relates to a 15 cfm per person design. Use the 1100 ppm curve on Fig. 17 to find the point when the CO₂ sensor output will be 6.7 volts. Line up the point on the graph with the left side of the chart to determine that the range configuration for the CO₂ sensor should be 1800 ppm. The Economizer controller will output the 6.7 volts from the CO₂ sensor to the actuator when the CO₂ concentration in the space is at 1100 ppm.

The DCV set point may be left at 2 volts since the CO₂ sensor voltage will be ignored by the Economizer controller until it rises above the 3.6 volt setting of the minimum position potentiometer.

Once the fully occupied damper position has been determined, set the maximum damper demand control ventilation potentiometer to this position. Do not set to the maximum position as this can result in overventilation to the space and potential high-humidity levels.

CO₂ SENSOR CONFIGURATION — The CO₂ sensor has preset standard voltage settings that can be selected anytime after the sensor is powered up. See Table 5.

Use setting 1 or 2 for equipment. See Table 5.

1. Press Clear and Mode buttons. Hold at least 5 seconds until the sensor enters the Edit mode.
2. Press Mode twice. The STDSET Menu will appear.
3. Use the Up/Down button to select the preset number. See Table 5.
4. Press Enter to lock in the selection.
5. Press Mode to exit and resume normal operation.

The custom settings of the CO₂ sensor can be changed anytime after the sensor is energized. Follow the steps below to change the nonstandard settings:

1. Press Clear and Mode buttons. Hold at least 5 seconds until the sensor enters the Edit mode.
2. Press Mode twice. The STDSET Menu will appear.
3. Use the Up/Down button to toggle to the NONSTD menu and press Enter.
4. Use the Up/Down button to toggle through each of the nine variables, starting with Altitude, until the desired setting is reached.
5. Press Mode to move through the variables.
6. Press Enter to lock in the selection, then press Mode to continue to the next variable.

DEHUMIDIFICATION OF FRESH AIR WITH DCV CONTROL— Information from ASHRAE indicates that the largest humidity load on any zone is the fresh air introduced. For some applications, an energy recovery unit can be added to reduce the moisture content of the fresh air being brought into the building when the enthalpy is high. In most cases, the normal heating and cooling processes are more than adequate to remove the humidity loads for most commercial applications.

If normal rooftop heating and cooling operation is not adequate for the outdoor humidity level, an energy recovery unit and/or a dehumidification option should be considered.

OPERATION

Sequence of Operation—When free cooling is not available, the compressor will be controlled by the thermostat. When free cooling is available, the outdoor-air damper is modulated by the Economizer control to provide a 50 to 55°F (10° to 12.8°C) supply-air temperature into the zone. As the supply-air temperature fluctuates above 55° (12.8°C) or below 50°F (10°C), the dampers will be modulated (open or close) to bring the supply-air temperature back within the set points.

For Economizer operation, there must be a thermostat call for the fan (G). This will move the damper to its minimum position during the occupied mode.

Above 50°F (10°C) supply-air temperature, the dampers will modulate from 100% open to the minimum open position. From 50°F to 45°F (10° to 7.2°C) supply-air temperature, the dampers will maintain at the minimum open position. Below 45°F (7.2°C), the dampers will be completely shut. As the supply-air temperature rises, the dampers will come back open to the minimum open position once the supply-air temperature rises to 48°F (8.9°C).

If power exhaust is installed, as the outdoor-air damper opens and closes, the power exhaust fans will be energized and deenergized.

If field-installed accessory CO₂ sensors are connected to the Economizer control, a demand controlled ventilation strategy will begin to operate. As the CO₂ level in the zone increases above the CO₂ set point, the minimum position of the damper will be increased proportionally. As the CO₂ level decreases because of the increase in fresh air, the outdoor-air damper will be proportionally closed. Damper position will follow the higher demand condition from DCV mode or free cooling mode. Damper movement from full closed to full open (or vice versa) will take between 1 1/2 and 2 1/2 minutes.

If free cooling can be used as determined from the appropriate changeover command (switch, dry bulb, enthalpy curve, differential dry bulb, or differential enthalpy), a call for cooling (Y1 closes at the thermostat) will cause the control to modulate the dampers open to maintain the supply air temperature set point at 50° to 55° F (10° to 12.8° C).

As the supply air temperature drops below the set point range of 50° to 55° F (10° to 12.8° C), the control will modulate the outdoor-air dampers closed to maintain the proper supply-air temperature.

Table 5 - CO₂ Sensor Standard Settings

SETTING	EQUIPMENT	OUTPUT	VENTILATION RATE (cfm/Person)	ANALOG OUTPUT	CO ₂ CONTROL RANGE (ppm)	OPTIONAL RELAY SETPOINT (ppm)	RELAY HYSTERESIS (ppm)
1	Interface w/Standard Building Control System	Proportional	Any	0-10V 4-20 mA	0-2000	1000	50
2		Proportional	Any	2-10v 7-20mA	0-2000	1000	50
3		Exponential	Any	0-10V 4-20mA	0-2000	1100	50
4	Economizer	Proportional	15	0-10V 4-20mA	0-1100	1100	50
5		Proportional	20	0-10V 4-20mA	0-900	900	50
6		Exponential	15	0-10V 4-20mA	0-1100	1100	50
7		Exponential	20	0-10V 4-20mA	0-900	900	50
8	Health & Safety	Proportional	--	0-10V 4-20mA	0-9999	5000	500
9	Parking/ Air Intakes/ Loading Docks	Proportional	--	0-10V 4-20mA	0-2000	700	50

Airflow data in downflow configuration with economizer, wet coil and 1 in (25.4mm) filter

Model Capacity	Unit Base	Motor Speed	Wire Color		External Static Pressure (in W.C.)									
					0.1	0.2	0.3	0.4	0.5	0.6	0.7	0.8	0.9	1.0
36*	Composite	High	Black	SCFM	1612	1569	1527	1481	1451	1393	1351	1317	1278	1242
36*	Base Rail	High	Black	SCFM	1612	1569	1527	1481	1451	1393	1351	1317	1278	1242
42	Composite	High	Black	SCFM	1612	1569	1527	1481	1451	1393	1351	1317	1278	1242
42	Base Rail	High	Black	SCFM	1612	1569	1527	1481	1451	1393	1351	1317	1278	1242
48	Composite	High	Black	SCFM	2298	2239	2180	2110	2044	1951	1862	1777	1697	1591
48	Base Rail	High	Black	SCFM	2166	2085	2002	1919	1798	1709	1582	1467	1270	988
48*	Base Rail	High	Black	SCFM	2298	2239	2180	2110	2044	1951	1862	1777	1697	1591
60	Composite	High	Black	SCFM	2000	1926	1825	1820	1759	1705	1634	1496	1412	1328
60	Base Rail	High	Black	SCFM	2298	2239	2180	2110	2044	1951	1862	1777	1697	1591

***14 SEER Heat Pump and Dual Fuel Models Only**

TROUBLESHOOTING

See Table 6 for Economizer logic.

An Economizer simulator program is available to help with Economizer training and troubleshooting.

Economizer Preparation —This procedure is used to prepare the Economizer for troubleshooting. No troubleshooting or testing is done by performing the following procedure.

NOTE: This procedure requires a 9-v battery, 1.2 kilo-ohm resistor, and a 5.6 kilo-ohm resistor which are not supplied with the Economizer.

1. Disconnect power at TR and TR1. All LEDs should be off. Exhaust fan contacts should be open.
2. Disconnect device at P and P1.
3. Jumper P to P1.
4. Disconnect wires at T and T1. Place 5.6 kilo-ohm resistor across T and T1.
5. Jumper TR to 1.
6. Jumper TR to N.
7. If connected, remove sensor from terminals S_o and +. Connect 1.2 kilo-ohm 4074EJM checkout resistor across terminals S_o and +.
8. Put 620-ohm resistor across terminals SR and +.
9. Set minimum position, DCV set point, and exhaust potentiometers fully CCW (counterclockwise).
10. Set DCV maximum position potentiometer fully CW (clockwise).
11. Set enthalpy potentiometer to D.
12. Apply power (24 vac) to terminals TR and TR1.

Differential Enthalpy — To check differential enthalpy:

1. Make sure Economizer preparation procedure has been performed.
2. Place 620-ohm resistor across S_o and +.
3. Place 1.2 kilo-ohm resistor across S_r and +. The Free Cool LED should be lit.
4. Remove 620-ohm resistor across S_o and +. The Free Cool LED should turn off.
5. Return Economizer settings and wiring to normal after completing troubleshooting.

Single Enthalpy—To check single enthalpy:

1. Make sure Economizer preparation procedure has been performed.
2. Set the enthalpy potentiometer to A (fully CCW). The Free Cool LED should be lit.
3. Set the enthalpy potentiometer to D (fully CW). The Free Cool LED should turn off.
4. Return Economizer settings and wiring to normal after completing troubleshooting.

DCV (Demand Controlled Ventilation) and Power Exhaust—To check DCV and Power Exhaust:

1. Make sure Economizer IV preparation procedure has been performed.
2. Ensure terminals AQ and AQ1 are open. The LED for both DCV and Exhaust should be off. The actuator should be fully closed.
3. Connect a 9-v battery to AQ (positive node) and AQ1 (negative node). The LED for both DCV and Exhaust should turn on. The actuator should drive to between 90 and 95% open.
4. Turn the Exhaust potentiometer CW until the Exhaust LED turns off. The LED should turn off when the potentiometer is approximately 90%. The actuator should remain in position.
5. Turn the DCV set point potentiometer CW until the DCV LED turns off. The DCV LED should turn off when the potentiometer is approximately 9-v. The actuator should drive fully closed.
6. Turn the DCV and Exhaust potentiometers CCW until the

Exhaust LED turns on. The exhaust contacts will close 30 to 120 seconds after the Exhaust LED turns on.

7. Return Economizer settings and wiring to normal after completing troubleshooting.

DCV Minimum and Maximum Position —To check the DCV minimum and maximum position:

1. Make sure Economizer preparation procedure has been performed.
2. Connect a 9-v battery to AQ (positive node) and AQ1 (negative node). The DCV LED should turn on. The actuator should drive to between 90 and 95% open.
3. Turn the DCV Maximum Position potentiometer to midpoint. The actuator should drive to between 20 and 80% open.
4. Turn the DCV Maximum Position potentiometer to fully CCW. The actuator should drive fully closed.
5. Turn the Minimum Position potentiometer to midpoint. The actuator should drive to between 20 and 80% open.
6. Turn the Minimum Position Potentiometer fully CW. The actuator should drive fully open.
7. Remove the jumper from TR and N. The actuator should drive fully closed.
8. Return Economizer settings and wiring to normal after completing troubleshooting.

Supply-Air Input—To check supply-air input:

1. Make sure Economizer preparation procedure has been performed.
2. Set the Enthalpy potentiometer to A. The Free Cool LED turns on. The actuator should drive to between 20 and 80% open.
3. Remove the 5.6 kilo-ohm resistor and jumper T to T1. The actuator should drive fully open.
4. Remove the jumper across T and T1. The actuator should drive fully closed.
5. Return Economizer settings and wiring to normal after completing troubleshooting.

Economizer Troubleshooting Completion —

This procedure is used to return the Economizer to operation. No troubleshooting or testing is done by performing the following procedure.

1. Disconnect power at TR and TR1.
2. Set enthalpy potentiometer to previous setting.
3. Set DCV maximum position potentiometer to previous setting.
4. Set minimum position, DCV set point, and exhaust potentiometers to previous settings.
5. Remove 620-ohm resistor from terminals SR and +.
6. Remove 1.2 kilo-ohm checkout resistor from terminals S_o and +. If used, reconnect sensor from terminals S_o and +.
7. Remove jumper from TR to N.
8. Remove jumper from TR to 1.
9. Remove 5.6 kilo-ohm resistor from T and T1. Reconnect wires at T and T1.
10. Remove jumper from P to P1. Reconnect device at P and P1.
11. Apply power (24 vac) to terminals TR and TR1.

Table 6 - Economizer Input/Output Logic

Demand Control Ventilation (DCV)	INPUTS				OUTPUTS			
	Enthalpy		Y1	Y2	Compressor		N Terminal	
	Outdoor	Return			Stage 1	Stage 2	Occupied	Unoccupied
Below set (DCV LED Off)	High (Free Cooling LED Off)	Low	On	On	On	On	Minimum position	Closed
			On	Off	On	Off		
			Off	Off	Off	Off		
	Low (Free Cooling LED On)	High	On	On	On	Off	Modulating** (between min. position and full-open)	Modulating** (between closed and full-open)
			On	Off	Off	Off		
			Off	Off	Off	Off		
Above set (DCV LED On)	High (Free Cooling LED Off)	Low	On	On	On	On	Modulating†† (between min. position and DCV maximum)	Modulating†† (between closed and DCV maximum)
			On	Off	On	Off		
			Off	Off	Off	Off		
	Low (Free Cooling LED On)	High	On	On	On	Off	Modulating***	Modulating†††
			On	Off	Off	Off		
			Off	Off	Off	Off		

*For single enthalpy control, the module compares outdoor enthalpy to the ABCD set point.

†Power at N terminal determines Occupied/Unoccupied setting: 24 vac (Occupied), now power (Unoccupied).

**Modulating is based on the supply-air sensor signal.

††Modulation is based on the DCV signal.

***Modulation is based on the greater of DCV and supply-air sensor signals, between minimum position and either maximum position (DCV) or fully open (supply-air signal).

†††Modulating is based on the greater of DCV and supply-air sensor signals, between closed and wither maximum position (DCV) or fully open (supply-air signal).

WIRING FOR AC AND GAS/ELECTRIC MODELS

POTENTIOMETER DEFAULT SETTINGS:

- POWER EXHAUST MIDDLE
- MINIMUM POS. FULLY CLOSED
- DCV MAX. MIDDLE
- DCV SET. MIDDLE
- ENTHALPY C SETTING

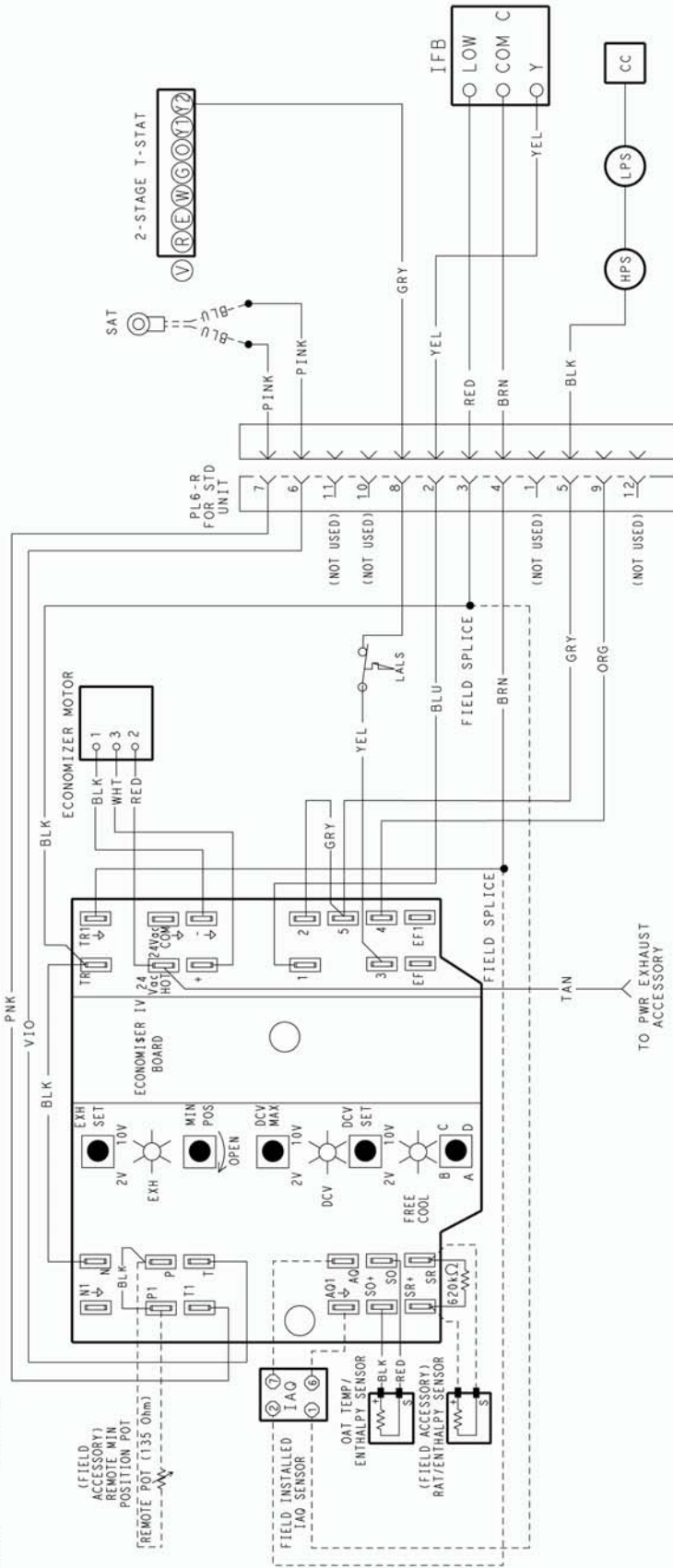

LEGEND

- SPLICE
- FACTORY WIRING
- FIELD OR ACCESSORY CONTROL WIRING
- CC COMPRESSOR CONTACTOR
- DVC DEMAND CONTROLLED VENTILATION
- HPS HIGH PRESSURE SWITCH
- IAQ INDOOR AIR QUALITY SENSORS
- IFB INDOOR FAN BOARD
- LALS LOW TEMPERATURE COMPRESSOR LOCKOUT SWITCH
- LPS LOW PRESSURE SWITCH
- OAT OUTDOOR AIR TEMPERATURE SENSOR
- POT POTENTIOMETER
- RAT RETURN AIR TEMPERATURE SENSOR

- NOTES:
1. 620 OHM, 1 WATT 5% RESISTOR SHOULD BE REMOVED ONLY WHEN USING DIFFERENTIAL ENTHALPY OR DRY BULB.
 2. IF A SEPARATE FIELD SUPPLIED 24V TRANSFORMER IS USED FOR THE TRANSFORMER GROUND, IT CANNOT HAVE THE SECONDARY OF THE TRANSFORMER GROUND.
 3. FOR FIELD INSTALLED REMOTE MINIMUM POSITION POT, REMOVE BLACK WIRE JUMPER BETWEEN P AND P1 AND SET CONTROL MINIMUM POSITION POT TO THE MINIMUM POSITION.

WIRING FOR HEAT PUMP AND DUAL FUEL MODELS

POTENTIOMETER DEFAULT SETTINGS:

- POWER EXHAUST MIDDLE
- MINIMUM POS. FULLY CLOSED
- DCV MAX. MIDDLE
- DCV MIN. MIDDLE
- ENTHALPY C SETTING

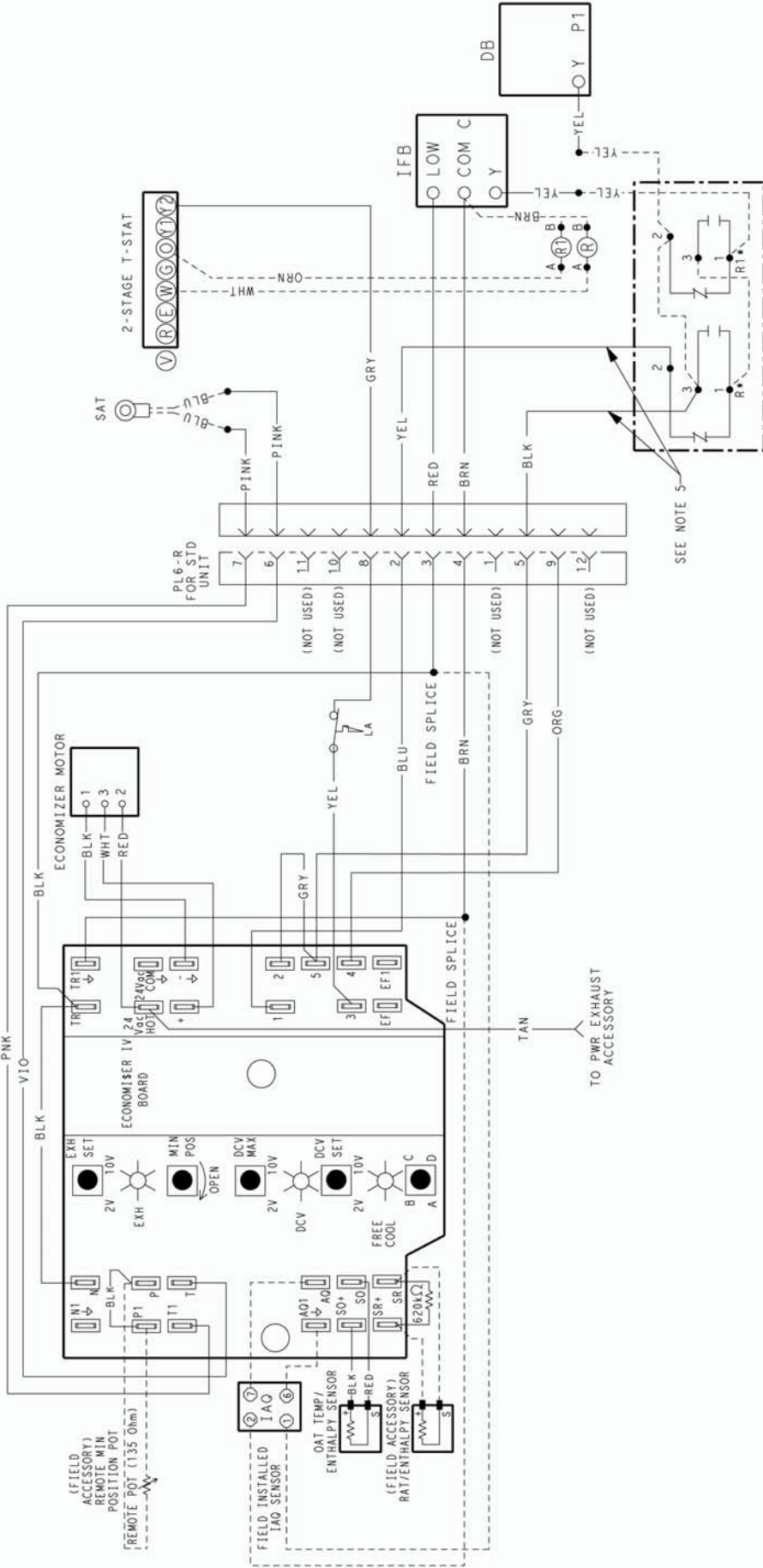

LEGEND

- SPLICE
- FACTORY WIRING
- FIELD OR ACCESSORY CONTROL WIRING
- DB DEFROST BOARD
- HPS HIGH PRESSURE SWITCH
- IAQ INDOOR AIR QUALITY SENSORS
- IFB INDOOR FAN BOARD
- LA LOW AMBIENT LOCKOUT
- LPS LOW PRESSURE SWITCH
- OAT OUTDOOR AIR TEMPERATURE SENSOR
- POT POTENTIOMETER
- R RELAY (FOR HPS)
- R1 RELAY (FOR HPS)
- RAT RETURN AIR TEMPERATURE SENSOR
- SAT SUPPLY AIR TEMPERATURE SENSOR

*R AND R1 RELAYS ARE PART OF THE AVAILABLE CPRLK1001A00 RELAY KIT OR CAN BE FIELD PROVIDED AND INSTALLED.

ACCEPTABLE RELAYS INCLUDE:
 HONEYWELL - R5252B1174
 HONEYWELL - R5252B1174
 WHITE RODGERS - 91-1030001-13002
 WHITE RODGERS - 91-1020006-13302

- NOTES:
1. 620 OHM, 1 WATT 5% RESISTOR SHOULD BE REMOVED ONLY WHEN USING DIFFERENTIAL ENTHALPY OR DRY BULB.
 2. IF A SEPARATE FIELD SUPPLIED 24V TRANSFORMER IS USED FOR THE TRANSFORMER GROUNDED.
 3. FOR FIELD INSTALLED REMOTE MINIMUM POSITION POT, REMOVE BLACK WIRE JUMPER BETWEEN P AND P1 AND SET CONTROL MINIMUM POSITION POT TO THE MINIMUM POSITION.
 4. FOR HEAT PUMP UNITS THE AVAILABLE RELAY PACKAGE CPRLK1001A00 CAN BE ORDERED AND FIELD INSTALLED. CONTRACTOR MAY PROVIDE RELAYS AND WIRE ACCORDING TO THIS DIAGRAM. RELAYS MUST BE:
 - CLOSED - SAME POLARITY - MINIMUM T2SVA INRUSH.
 5. WIRING FACTORY INSTALLED. FIELD CONNECTION TO AVAILABLE RELAY KIT OR FIELD SUPPLIED RELAYS REQUIRED.

