

INSTALLATION INSTRUCTIONS

Accessory Hail Guard

CA(DA)LVHLGD001A00, CA(DA)LVHLGD002A00, CA(DA)LVHLGD003A00,

CA(DA)LVHLGD004A00, CA(DA)LVHLGD005A00, CA(DA)LVHLGD006A00,

CA(DA)LVHLGD010A00, CALVHLGD011A00, CALVHLGD012A00

6 to 12.5 Ton Split Cooling Unit, 6 to 10 Ton Split Heat Pump Unit

These instructions must be read and understood completely before attempting installation

Safety Labeling and Signal Words

DANGER, WARNING, CAUTION, and NOTE

The signal words **DANGER**, **WARNING**, **CAUTION**, and **NOTE** are used to identify levels of hazard seriousness. The signal word **DANGER** is only used on product labels to signify an immediate hazard. The signal words **WARNING**, **CAUTION**, and **NOTE** will be used on product labels and throughout this manual and other manual that may apply to the product.

DANGER – Immediate hazards which will result in severe personal injury or death.

WARNING – Hazards or unsafe practices which could result in severe personal injury or death.

CAUTION – Hazards or unsafe practices which may result in minor personal injury or product or property damage.

NOTE – Used to highlight suggestions which will result in enhanced installation, reliability, or operation.

Signal Words in Manuals

The signal word **WARNING** is used throughout this manual in the following manner:

 **WARNING**

The signal word **CAUTION** is used throughout this manual in the following manner:

 **CAUTION**

Signal Words on Product Labeling

Signal words are used in combination with colors and/or pictures or product labels.

PACKAGE USAGE

Hail Guard Number	Coil Type	CAS	CHS
CALVHLGD001A00 DALVHLGD001A00	MCHX	072	NA
CALVHLGD002A00 DALVHLGD002A00	MCHX	091	NA
CALVHLGD003A00 DALVHLGD003A00	MCHX	120, 121	NA
CALVHLGD004A00 DALVHLGD004A00	MCHX	150, 151	NA
CALVHLGD005A00 DALVHLGD005A00	RTPF	072	072
CALVHLGD006A00 DALVHLGD006A00	RTPF	090, 091	091
CALVHLGD010A00 DALVHLGD010A00	RTPF	NA	121
CALVHLGD011A00	RTPF	120, 121	NA
CALVHLGD012A00	RTPF	150, 151	NA

SAFETY CONSIDERATIONS

Installation and servicing of this equipment can be hazardous due to mechanical and electrical components. Only trained and qualified personnel should install, repair, or service this equipment.

Untrained personnel can perform basic maintenance functions such as cleaning and replacing air filters. All other operations must be performed by trained service personnel. When working on this equipment, observe precautions in the literature, on tags, and on labels attached to or shipped with the unit and other safety precautions that may apply.

Follow all safety codes. Wear safety glasses, protective clothing, and work gloves. Use quenching cloth for brazing operations. Have fire extinguisher available. Read these instructions thoroughly and follow all warnings or cautions included in literature and attached to the unit. Consult local building codes, the current editions of the National Electrical Code (NEC) NFPA 70. In Canada refer to the current editions of the Canadian Electrical Code CSA C22.1.

Recognize safety information. This is the safety-alert symbol . When you see this symbol on the unit and in instructions or manuals, be alert to the potential for personal injury. Understand these signal words: DANGER, WARNING, and CAUTION. These words are used with the safety-alert symbol. DANGER identifies the most serious hazards which **will** result in severe personal injury or death. WARNING signifies hazards which **could** result in personal injury or death. CAUTION is used to identify unsafe practices which **may** result in minor personal injury or product and property damage. NOTE is used to highlight suggestions which **will** result in enhanced installation, reliability, or operation.

 <h3 style="margin: 0;">WARNING</h3>
<p>ELECTRICAL SHOCK HAZARD</p> <p>Failure to follow this warning could cause personal injury or death.</p> <p>Before beginning any modification on unit, always turn off main power switch to unit and install lockout tag. Unit may have more than one power switch.</p>

 <h3 style="margin: 0;">CAUTION</h3>
<p>CUT HAZARD</p> <p>Failure to follow this caution may result in personal injury.</p> <p>Sheet metal parts may have sharp edges or burrs. Use care and wear appropriate clothing.</p>

PACKAGE CONTENTS AND USAGE

HAIL GUARD PKG PART NO.	PACKAGE CONTENTS	PANEL USE LOCATION
CALVHLGD001A00 DALVHLGD001A00	(2) Hail Guards:	----
	(1) – 37.4 x 41.6	BACK
	(1) – 37.4 x 32.6	LEFT SIDE
	(6) #10 x 1/2 Screws	----
CALVHLGD002A00 DALVHLGD002A00	(4) Grommets	----
	(2) Hail Guards:	----
	(1) – 37.4 x 41.6	BACK
	(1) – 37.4 x 44.6	LEFT SIDE
CALVHLGD003A00 DALVHLGD003A00	(6) #10 x 1/2 Screws	----
	(4) Grommets	----
	(2) Hail Guards:	----
	(1) – 45.4 x 41.6	BACK
CALVHLGD004A00 DALVHLGD004A00	(1) – 45.4 x 44.6	LEFT SIDE
	(6) #10 x 1/2 Screws	----
	(4) Grommets	----
	(3) Hail Guards:	----
CALVHLGD005A00 DALVHLGD005A00	(1) – 45.4 x 42.4	BACK
	(1) – 45.4 x 44.6	LEFT SIDE
	(1) – 45.4 x 24.9	RIGHT SIDE
	(8) #10 x 1/2 Screws	----
CALVHLGD006A00 DALVHLGD006A00	(8) Grommets	----
	(2) Hail Guards:	----
	(1) – 37.4 x 41.6	BACK
	(1) – 37.4 x 30.6	LEFT SIDE
CALVHLGD007A00 DALVHLGD007A00	(6) #10 x 1/2 Screws	----
	(4) Grommets	----
	(3) Hail Guards:	----
	(1) – 37.4 x 42.4	BACK
CALVHLGD008A00 DALVHLGD008A00	(1) – 37.4 x 30.6	LEFT SIDE
	(1) – 37.4 x 26.5	RIGHT SIDE
	(8) #10 x 1/2 Screws	----
	(8) Grommets	----
CALVHLGD009A00 DALVHLGD009A00	(3) Hail Guards:	----
	(1) – 45.4 x 42.4	BACK
	(1) – 45.4 x 30.6	LEFT SIDE
	(1) – 45.4 x 26.5	RIGHT SIDE
CALVHLGD010A00 DALVHLGD010A00	(8) #10 x 1/2 Screws	----
	(8) Grommets	----
	(3) Hail Guards:	----
	(1) – 45.4 x 42.4	BACK
CALVHLGD011A00	(1) – 45.4 x 30.6	LEFT SIDE
	(1) – 45.4 x 26.5	RIGHT SIDE
	(8) #10 x 1/2 Screws	----
	(8) Grommets	----
CALVHLGD0011A00	TBA	TBA
CALVHLGD012A00	TBA	TBA

GENERAL

Louvered hail guard packages are designed to protect the unit condenser coil from hail and general contact damage. Excessive damage to unit outdoor coils can result in diminished performance due to reduced air flow over the heat transfer surfaces.

IMPORTANT: Never drill or use screws through the top cover to secure hail guards. Coil damage could occur.

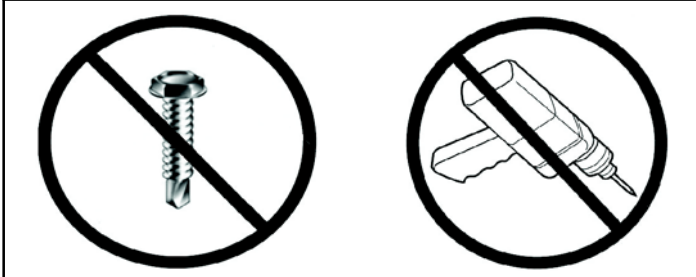

INSTALLATION

1. Verify the correct hail guard sizes are provided for the desired unit size. See Package Usage section above.
2. Hold each hail guard panel in place and remove the screws at the base of the outdoor coil and the vertical side of the coil that line up with each of the hail guard panel holes to be installed. Save the screws.
3. Insert plastic grommets in the square holes of each corner post as shown in Fig. 3.
4. Align the hail guard panel with the respective section of the outdoor coil and insert the top edge of the hail guard panel under the lip of the top cover. (See Fig. 1, 2, and 4.)
5. Reinstall screws removed from Step 2. Using screws provided with kit, fasten panel at corner post ends through panel and into the installed grommets.

FIGURE 1 Typical 2 - Panel Hail Guard Installation

Uses 4 grommets at one corner

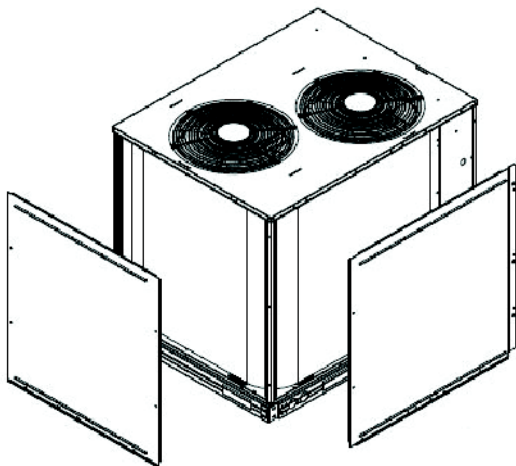

FIGURE 2 Typical Third Panel hail Guard Installation

Uses 8 grommets, four each of two corner posts.

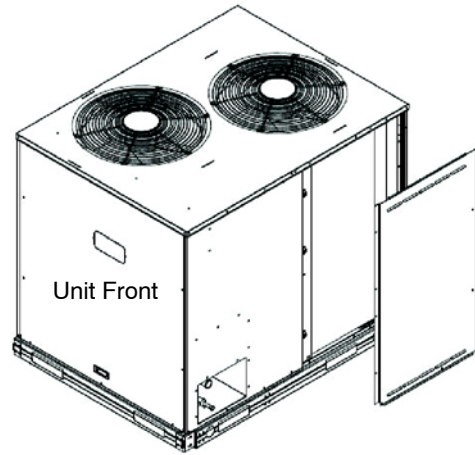

FIGURE 3 Grommets in Corner Post

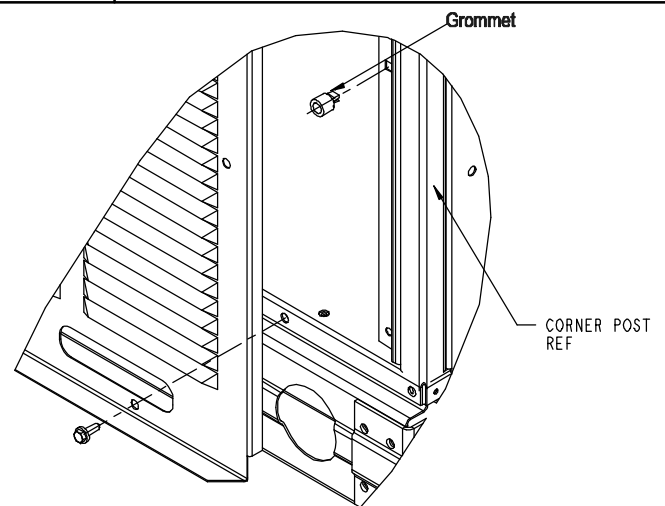

FIGURE 4 Hail Guard Panel into Top Cover (Use no screws)

Important: Never drill or use screws through the top cover to secure hail guards. Coil damage could occur.

