

**RGH/RAH/RHH/RGS/RAS/RHS  
SINGLE PACKAGE ROOFTOP UNITS  
3 to 27.5 Nominal Tons**

**FACTORY INSTALLED ECONOMIZERS  
Economizer Supplement Related To  
California Title 24**

**California's new Title 24 is effective July 1, 2014 and requires several new economizer features.**

**This supplement details these economizer updates and is to be used in conjunction with the base unit installation instructions for the following 3 to 27.5 nominal ton models: RGH/RAH/RHH/RGS/RAS/RHS.**

**Supplement Index:**

- Economiser X Title 24 electro-mechanical offerings and definitions . . . . . Pages 2-21  
This includes set up, start up and menu structure information.

*Title 24 Note: Because the economizer factory-installed in the unit is Title 24 listed by the California Energy Commission (CEC), field economizer commissioning is not required.*

## Title 24 Economizer X Supplement ELECTRO-MECHANICAL CONTROLS

The economizer factory-installed in this rooftop unit meets some parts or all of the requirements of the new California Title 24 economizer standards.

There are (2) significant parts to the economizer section of Title 24:

- **Mandatory section 120.2** Economizer Fault Detection and Diagnostics (FDD). This section’s intent is to allow only California Energy Commission (CEC) listed economizer controllers to be used to properly determine when an economizer control system fails and identifying the specific failure. Bryant offers the Economizer X control system, using the W7220 Honeywell controller, that meet the mandatory section 120.2 FDD requirements:
- **Prescriptive section 140.4** deals with several economizer related issues including minimal damper leakage, damper life cycle testing, 5 year economizer warranty, etc. Because section 140.4 is “prescriptive” they may not be required on some jobs. When an economizer with “Ultra Low Leak” dampers is ordered, it meets the section 140.4 requirements.

**NOTE:** These economizers also meet ASHRAE 90.1 requirements.

Factory-installed economizers that meet some or all of Title 24 are:

<i><b>ECONOMIZER TYPE</b></i>	<i><b>CONTROLLER</b></i>	<i><b>DAMPER</b></i>	<i><b>MEETS TITLE 24</b></i>
<i>Economizer X</i>	<i>Honeywell W7220</i>	<i>Ultra Low Leak</i>	<i>Section 120.2 and 140.4</i>
<i>Economizer X</i>	<i>Honeywell W7220</i>	<i>Standard Leak</i>	<i>Section 120.2</i>

The Economizer X W7220 controller is factory set for either a 1 speed or 2 speed unit, depending upon the unit ordered.

The following section provides general information and typical wiring diagrams for the W7220 controller.

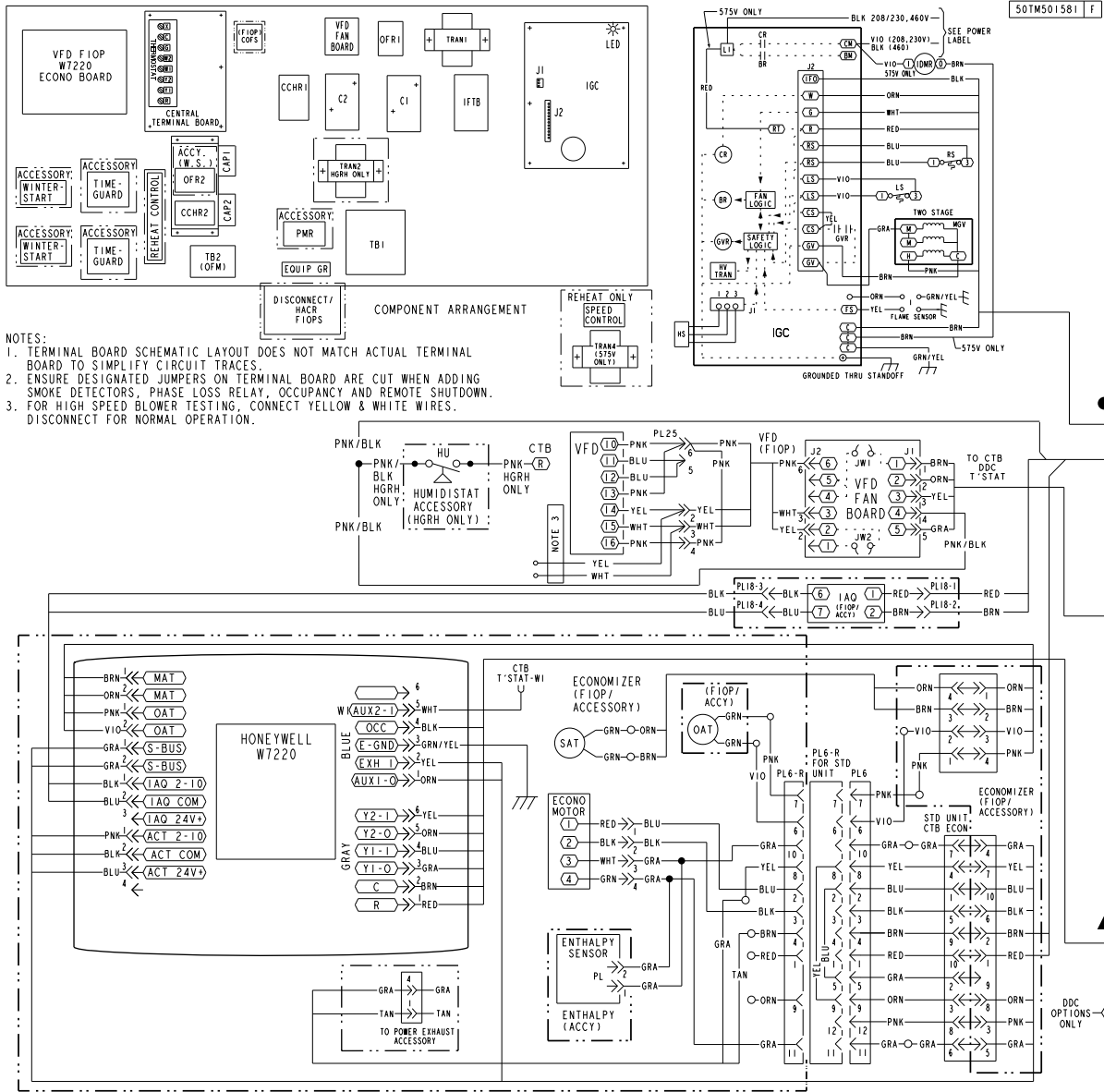

**Fig. 1 – Example of an Economizer X Wiring Diagram for a 2 Speed Unit –**  
**NOTE: For details pertaining to a specific unit, see the Wiring Diagram label on the unit.**

C14153

## SAFETY CONSIDERATIONS

Improper installation, adjustment, alteration, service, maintenance, or use can cause explosion, fire, electrical shock or other conditions which may cause personal injury or property damage. Consult a qualified installer, service agency, or your distributor or branch for information or assistance. The qualified installer or agency must use factory-authorized kits or accessories when modifying this product. Refer to the individual instructions packaged with the kits or accessories when installing.

Follow all safety codes. Wear safety glasses and work gloves. Use quenching cloths for brazing operations and have a fire extinguisher available. Read these instructions thoroughly and follow all warnings or cautions attached to the unit. Consult local building codes and appropriate national electrical codes (in USA, ANSI/NFPA70, National Electrical Code (NEC); in Canada, CSA C22.1) for special requirements.

It is important to recognize safety information. This is the safety-alert symbol . When you see this symbol on the unit and in instructions or manuals, be alert to the potential for personal injury.

Understand the signal words DANGER, WARNING, CAUTION, and NOTE. These words are used with the safety-alert symbol.

DANGER identifies the most serious hazards which **will** result in severe personal injury or death. WARNING signifies hazards which **could** result in personal injury or death.

CAUTION is used to identify unsafe practices, which **may** result in minor personal injury or product and property damage.

NOTE is used to highlight suggestions which **will** result in enhanced installation, reliability, or operation.

## WARNING

### ELECTRICAL SHOCK HAZARD

Failure to follow this warning could cause personal injury or death.

Before performing service or maintenance operations on unit, always turn off main power switch to unit and install lock(s) and lockout tag(s). Unit may have more than one power switch. Ensure electrical service to rooftop unit agrees with voltage and amperage listed on the unit rating plate.

## CAUTION

### CUT HAZARD

Failure to follow this caution may result in personal injury.

Sheet metal parts may have sharp edges or burrs. Use care and wear appropriate protective clothing, safety glasses and gloves when handling parts and servicing air conditioning equipment.

# W7220 ECONOMIZER MODULE



**Fig. 2 – W7220 Economizer Module**

C14154

## Product Description

This economizer system is an expandable economizer control system, which includes a W7220 Economizer Module (controller) with an LCD and keypad. The W7220 can be configured with optional sensors.

The W7220 Economizer Module can be used as a stand-alone economizer module wired directly to a commercial set-back space thermostat and sensors to provide Outside Air dry-bulb economizer control.

The W7220 Economizer Module can be connected to optional sensors for single or differential enthalpy control. The W7220 Economizer Module provides power and communications for the sensors.

The W7220 Economizer Module automatically detects sensors by polling to determine which sensors are present. If a sensor loses communications after it has been detected, the W7220 Economizer indicates a device fail error on its LCD.

## System Components

The Economizer X system includes an Economizer module, 20k mixed air sensor, damper actuator, and either a 20k outdoor air temperature sensor or S-Bus enthalpy sensors.

## Economizer Module

This is the core of the Economizer X System, is mounted in the unit's control box, and includes the user interface for the system. The W7220 Economizer Module provides the basic inputs and outputs to provide simple economizer control. When used with the optional sensors, the Economizer Module provides more advanced economizer functionality.

## S-Bus Enthalpy Control Sensors

The S-bus enthalpy control sensor is a combination temperature and humidity sensor which is powered by and communicates on the S-Bus. Up to three sensors may be configured with the W7220 Economizer Module. See page 8 for details.

## CO<sub>2</sub> Sensor (optional)

A CO<sub>2</sub> sensor can be added for Demand Control Ventilation (DCV).



C14159



C14160



E4436

C14161

# SPECIFICATIONS

## W7220 Economizer Module

The module is designed for use with 2 to 10Vdc or bus communicating actuator. The module includes terminals for CO<sub>2</sub> sensor, Mixed Air sensor, and an Outdoor Dry Bulb sensor. Enthalpy and other options are available with bus sensors.

**User Interface:** Provides status for normal operation, setup parameters, checkout tests, and alarm and error conditions with a 2-line 16 character LCD display and four button keypad.

### Electrical

**Rated Voltage:** 20 to 30 Vac RMS, 50/60 Hz  
Transformer: 100 va maximum system input

**Nominal Power Consumption (at 24 Vac, 60 Hz):**  
11.5 VA without sensors or actuators

**Relay Digital Output Rating at 30 Vac (maximum power from Class 2 input only):** 1.5A run:  
3.5A inrush @ 0.45PF (200,000 cycles) or  
7.5A inrush @ 0.45PF (100,000 cycles)

**External Sensors Power Output:** 21 Vdc ± 5% @ 48mA

**IMPORTANT:** All inputs and outputs must be Class 2 wiring.

### Inputs

#### SENSORS:

**NOTE:** A Mixed Air (MA) analog sensor is required on all W7220 units; either an Outdoor Air (OA) sensor for dry bulb change over or an OA bus sensor for outdoor enthalpy change over is required in addition to the MA sensor. An additional Return Air (RA) bus sensor can be added to the system for differential enthalpy or dry bulb changeover. For differential dry bulb changeover a 20k ohm sensor is required in the OA and a bus sensor in the RA. Dip switch on RA bus sensor must be set in the RA position.

#### Dry Bulb Temperature (optional) and Mixed Air (required), C7250A:

2-wire (18 to 22 AWG);  
Temperature range -40 to 150°F (-40 to 65°C).  
Temperature accuracy -0°F/+2°F

#### Temperature and Humidity, C7400S1000 (optional):

S-Bus; 2-wire (18 to 22 AWG)  
Temperature: range -40 to 150°F (-40 to 65°C)  
Temperature accuracy -0°F/+2°F  
Humidity: range 0 to 100% RH with 5% accuracy.

**NOTE:** Up to three (3) S-Bus sensors may be connected to the W7220 Economizer module. For outdoor air (OA), return air (RA) and discharge (supply) air (DA).

#### 4 Binary inputs:

1-wire 24 Vac + common GND (see page 8 for wiring details). 24 Vac power supply: 20 to 30 Vac 50/60Hz; 100 VA Class 2 transformer.

### Outputs

**Actuator signal:** 2-10 Vdc; minimum actuator impedance is 2k ohm; bus two-wire output for bus communicating actuators.

#### Exhaust fan, Y1, Y2 and AUX1 O:

All Relay Outputs (at 30 Vac):  
Running: 1.5A maximum  
Inrush: 7.5A maximum

### Environmental

**Operating Temperature:** -40 to 150°F (-40 to 65°C). Exception of display operation down to -4°F with full recovery at -4°F from exposure to -40°F

**Storage Temperature:** -40 to 150°F (-40 to 65°C)

**Shipping Temperature:** -40 to 150°F (-40 to 65°C)

**Relative Humidity:** 5% to 95% RH non-condensing

**Dimensions (see Fig. 3, below):**

Height: 4.98 inches (126.4 mm)

Width: 6.3 inches (160 mm)

Depth: 1.34 inches (34 mm)

**Weight:** 0.58 lb. (0.265 kg)

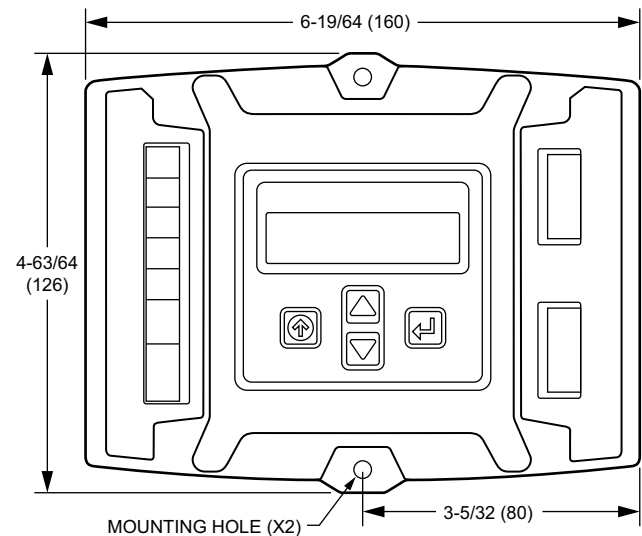

Fig. 3 - Dimensions for Mounting Holes in Inches (mm)

C14155

## BEFORE INSTALLATION

Review the "SPECIFICATIONS" (above) before installing the W7220A economizer module.

### When Installing This Product

1. Read these instructions carefully. Failure to follow them could damage the product or cause a hazardous condition.
2. Check ratings given in instructions and on the product to ensure the product is suitable for your application.
3. Installer must be a trained, experienced service technician.
4. After installation is complete, check out product operation as provided in these instructions.

**NOTE:** The W7220 will be in the "set up" mode for the first 60 minutes after powered. If a sensor for OA air or bus device (sensor, actuator) is disconnected during the set up mode, the W7220 will not alarm that failure. The MA sensor is a system "critical" sensor, if the MA sensor is removed during the set up mode, the W7220 will alarm. After 60 minutes the W7220 controller will change to operation mode and all components removed or failed will alarm in the operation mode.

## INSTALLATION AND SETUP

The following installation procedures should be performed in the order listed:

1. Mounting — see Fig. 3 (on page 6).
2. Wiring — see page 3.
3. Interface and Programming overview — see page 8.
4. Setup and Configuration — see page 9
5. Checkout — see page 20.

Troubleshooting and Alarms—see page 21.

### Economizer Module Wiring Details

The wiring connection terminals for each module/sensor are:

- "W7220 Economizer Module Wiring" on pages 7–8.
- "S–Bus Sensor Wiring" on page 8

### W7220 Economizer Module Wiring

Use Fig. 4 and Tables 1 and 2 to locate the wiring terminals for the Economizer module.

**NOTE:** The four terminal blocks are removable. You can slide out each terminal block, wire it, and then slide it back into place.

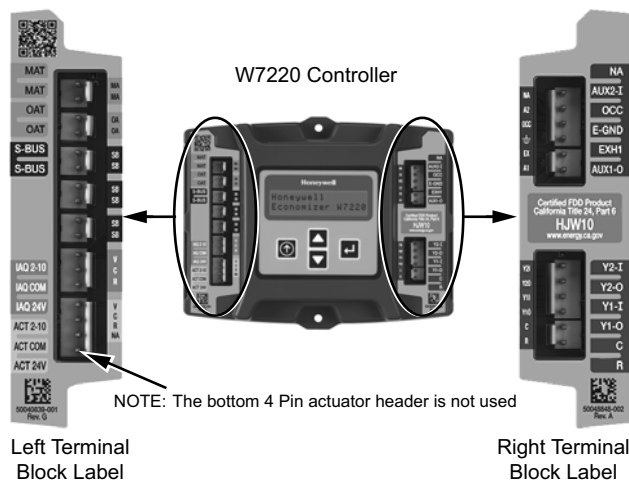

**Fig. 4 – W7220 Economizer Module Terminal Connection Labels.**

**Table 1 – Economizer Module – Left Hand Terminal Blocks**

Label	Type	Description
<b>Top Left Terminal Block</b>		
MAT MAT	20k NTC and COM	Supply Air Temperature Sensor (polarity insensitive connection)
OAT OAT	20k NTC and COM	Outdoor Air Temperature Sensor (polarity insensitive connection)
S–BUS S–BUS	S–Bus (Sylk Bus)	Enthalpy Control Sensor (polarity insensitive connection)
<b>Bottom Left Terminal Block</b>		
IAQ 2–10	2–10 Vdc	Air Quality Sensor Input (e.g. CO <sub>2</sub> sensor)
IAQ COM	COM	Air Quality Sensor Common
IAQ 24V	24 Vac	Air Quality Sensor 24 Vac Source
ACT 2–10	2–10 Vdc	Damper Actuator Output (2–10 Vdc)
ACT COM	COM	Damper Actuator Output Common
ACT 24V	24 Vac	Damper Actuator 24 Vac Source
	n/a	The bottom pin is not used.

**Table 2 – Economizer Module – Right Hand Terminal Blocks**

Label	Type	Description
<b>Top Right Terminal Block</b>		
	n/a	The first pin is not used
AUX2 I	24 Vac IN	Shut Down (SD) or Heat (W) Conventional only or Heat Pump Changeover (O/B) in Heat Pump mode.
OCC	24 Vac IN	Occupied / Unoccupied Input
E–GND	E–GND	Earth Ground – System Required
EXH1	24 Vac OUT	Exhaust Fan 1 Output
AUX1 O	24 Vac OUT	Programmable: Exhaust fan 2 output or System Alarm output
<b>Bottom Right Terminal Block</b>		
Y2–I	24 Vac IN	Y2 in – Cooling Stage 2 Input from space thermostat
Y2–O	24 Vac OUT	Y2 out – Cooling Stage 2 Output to stage 2 mechanical cooling
Y1–I	24 Vac IN	Y1 in – Cooling Stage 1 Input from space thermostat
Y1–O	24 Vac OUT	Y1 out – Cooling Stage 1 Output to stage 1 mechanical cooling
C	COM	24 Vac Common
R	24 Vac	24 Vac Power (Hot)

C14156

## S-Bus Sensor Wiring

The labels on the sensors and controller are color coded for ease of installation. Orange labeled sensors can only be wired to orange terminals on the controller. Brown labeled sensors can only be wired to S-bus (brown) terminals. Use Fig. 5 and Table 3 to locate the wiring terminals for each S-Bus sensor.

Use Fig. 5 and Table 4 to set the DIP switches for the desired used of the sensor.

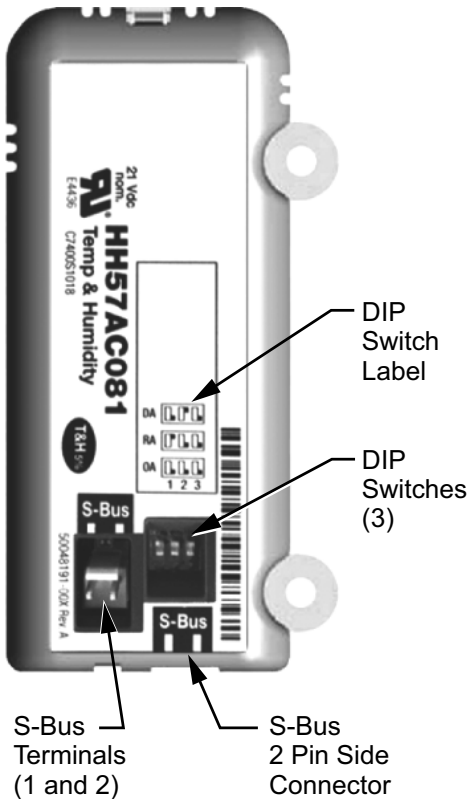

Fig. 5 – S-Bus Sensor DIP Switches

C14178

Table 3 – Enthalpy Control Sensor Wiring Terminations<sup>a</sup>

Terminal		Type	Description
Nbr	Label		
1	S-BUS	S-BUS	S-Bus Communications (Enthalpy Control Sensor Bus)
2	S-BUS	S-BUS	S-Bus Communications (Enthalpy Control Sensor Bus)

<sup>a</sup> Terminals are polarity insensitive.

Table 4 – Enthalpy Control Sensor DIP Switch Settings

Use	DIP Switch Positions for Switches 1, 2, & 3		
	1	2	3
DA <sup>a</sup>	OFF	ON	OFF
RA <sup>b</sup>	ON	OFF	OFF
OA <sup>c</sup>	OFF	OFF	OFF

<sup>a</sup> DA = Discharge Air

<sup>b</sup> RA = Return Air

<sup>c</sup> OA = Outside Air

**NOTE:** When a S-bus sensor is connected to an existing network, it will take 60 minutes for the network to recognize and auto-configure itself to use the new sensor. During the 60 minute setup period, no alarms for sensor failures (except SAT) will be issued and no economizing function will be available.

## CO<sub>2</sub> Sensor Wiring

When using a CO<sub>2</sub> sensor the black and brown common wires are internally connected and only one is connected to "IAQ COM" on the W7220. Use the power from the W7220 to power the CO<sub>2</sub> sensor OR make sure the ground for the power supplies are common. See Fig. 6 for CO<sub>2</sub> sensor wiring.

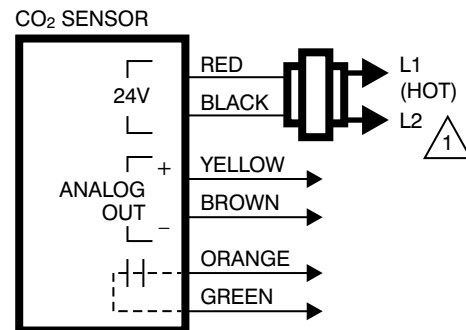

**1** POWER SUPPLY. PROVIDE DISCONNECT MEANS AND OVERLOAD PROTECTION AS REQUIRED.

Fig. 6 – Wiring for CO<sub>2</sub> Sensor

C14158

## INTERFACE OVERVIEW

This section describes how to use the Economizer's user interface for:

- Keypad and menu navigation
- Settings and parameter changes
- Menu structure and selection

## User Interface

The user interface consists of a 2-line LCD display and a 4-button keypad on the front of the economizer controller.

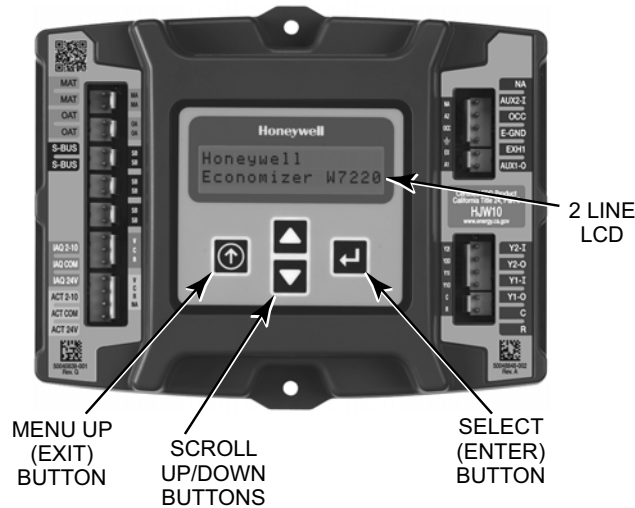

Fig. 7 – W7220 Controller

C14026

## Keypad

The four navigation buttons (see Fig. 7) are used to scroll through the menus and menu items, select menu items, and to change parameter and configuration settings.

### Using the Keypad with Menus

To use the keypad when working with menus:

- Press the ▲ (Up arrow) button to move to the previous menu.
- Press the ▼ (Down arrow) button to move to the next menu.
- Press the ↵ (Enter) button to display the first item in the currently displayed menu.
- Press the ⏪ (Menu Up/Exit) button to exit a menu's item and return to the list of menus.

### Using the Keypad with Settings and Parameters

To use the keypad when working with Setpoints, System and Advanced Settings, Checkout tests and Alarms:

1. Navigate to the desired menu.
2. Press the ↵ (Enter) button to display the first item in the currently displayed menu.
3. Use the ▲ and ▼ buttons to scroll to the desired parameter.
4. Press the ↵ (Enter) button to display the value of the currently displayed item.
5. Press the ▲ button to increase (change) the displayed parameter value.
6. Press the ▼ button to decrease (change) the displayed parameter value.

**NOTE:** When values are displayed, pressing and holding the ▲ or ▼ button causes the display to automatically increment.

7. Press the ↵ (Enter) button to accept the displayed value and store it in nonvolatile RAM.
8. "CHANGE STORED" displays.
9. Press the ↵ (Enter) button to return to the current menu parameter.
10. Press the ⏪ (Menu Up/Exit) button to return to the previous menu.

## Menu Structure

Table 5, starting on page 10, illustrates the complete hierarchy of menus and parameters for the Economizer X system.

The Menus in display order are:

- STATUS
- SETPOINTS
- SYSTEM SETUP
- ADVANCED SETUP
- CHECKOUT
- ALARMS

**IMPORTANT:** Table 5 illustrates the complete hierarchy. Your menu parameters may be different depending on your configuration.

For example if you do not have a DCV (CO<sub>2</sub>) sensor, then none of the DCV parameters appear and only MIN POS will display. If you have a CO<sub>2</sub> sensor, the DCV MIN and DCV MAX will appear AND if you have 2 speed fan DCV MIN (high and low speed) and DCV MAX (high and low speed will appear).

**NOTE:** Some parameters in the menu use the letters MA or MAT, indicating a mixed air temperature sensor location before the cooling coil. This unit application has the control sensor located after the cooling coil, in the fan section, where it is designated as (Cooling) Supply Air Temperature or SAT sensor.

## SETUP AND CONFIGURATION

Before being placed into service, the W7220 Economizer module must be setup and configured for the installed system.

**IMPORTANT:** During setup, the Economizer module is live at all times.

The setup process uses a hierarchical menu structure that is easy to use. You press the ▲ and ▼ arrow buttons to move forward and backward through the menus and press the ↵ button to select and confirm setup item changes.

### Time-out and Screensaver

When no buttons have been pressed for 10 minutes, the LCD displays a screen saver, which cycles through the Status items. Each Status items displays in turn and cycles to the next item after 5 seconds.

**Table 5 – Menu Structure<sup>a</sup>**

Menu	Parameter	Parameter Default Value	Parameter Range and Increment <sup>b</sup>	EXPANDED PARAMETER NAME Notes
STATUS	ECON AVAIL	NO	YES/NO	ECONOMIZING AVAILBLE YES = economizing available; the system can use outside air for free cooling when required
	ECONOMIZING	NO	YES/NO	ECONOMIZING ACTIVE YES = Outside air being used for 1 <sup>st</sup> stage cooling. NO = Economizing not active
	OCCUPIED	NO	YES/NO	OCCUPIED YES = OCC signal received from space thermostat or unitary controller. YES = 24 Vac on terminal OCC. NO = 0 Vac on terminal OCC.
	HEAT PUMP	n/a <sup>c</sup>	COOL HEAT	HEAT PUMP MODE Displays COOL or HEAT when system is set to heat pump (non-conventional)
	COOL Y1-IN	OFF	ON/OFF	FIRST STAGE COOLING DEMAND (Y1-IN) Y1-I signal from space thermostat or unitary controller for Cooling Stage 1. ON = 24 Vac on terminal Y1-I OFF = 0Vac on terminal Y1-I
	COOL Y1-OUT	OFF	ON/OFF	FIRST STAGE COOLING RELAY OUTPUT Cool Stage 1 Relay Output to mechanical cooling (Y1-OUT terminal).
	COOL Y2-IN	OFF	ON/OFF	SECOND STAVE COOLING DEMAND (Y2-IN) Y2-I signal from space thermostat or unitary controller for Cooling Stage 2. ON = 24 Vac on terminal Y2-I OFF = 0 Vac on terminal Y2-I
	COOL Y2-OUT	OFF	ON/OFF	SECOND STAGE COOLING RELAY OUTPUT Cool Stage 2 Relay Output to mechanical cooling (Y2-OUT terminal).
	MA TEMP	___°F (or ___°C)	-40 to 150°F (-18 to 60°C)	SUPPLY AIR TEMPERATRUE, Cooling Mode Displays value of measured mixed/cooled air from SAT sensor in fan section. Displays --- if not connected, short or out-of-range. See Menu Note 2
	DA TEMP	___°F (or ___°C)	-40 to 150°F (-18 to 60°C)	DISCHARGE AIR TEMPERATRUE, after Heating section (Accessory sensor required) Displays when Discharge Air sensor is connected and displays measured discharge temperature. Displays ---°F if sensor sends invalid value, if not connected, short or out-of-range.
	OA TEMP	___°F (or ___°C)	-40 to 140°F (-40 to 60°C)	OUTSIDE AIR TEMPERATRUE Displays measured value of outdoor air temperature. Displays ---°F if sensor sends invalid value, if not connected, short or out-of-range.
	OA HUM	__%	0 to 100%	OUTSIDE AIR RELATIVE HUMIDITY Displays measured value of outdoor humidity from OA enthalpy sensor.
	RA TEMP	___°F (or ___°C)	0 to 140°F (-18 to 60°C)	RETURN AIR TEMPERATRUE (Accessory sensor required) Displays measured value of return air temperature from RAT sensor. Displays ---°F if sensor sends invalid value, if not connected, short or out-of-range.
	RA HUM	__%	0 to 100%	RETURN AIR RELATIVE HUMIDITY (Accessory enthalpy sensor required) Displays measured value of return air humidity from RA sensor. Displays ---% if sensor sends invalid value, if not connected, short or out-of-range.
	IN CO2	___ ppm	0 to 2000 ppm	SPACE/RETURN AIR CO2 (CO <sub>2</sub> sensor required, accessory or factory option) Displays value of measured CO <sub>2</sub> from CO <sub>2</sub> sensor. Invalid if not connected, short or out-of-range. May be adjusted in Advanced menu by Zero offset and Span.
	DCV STATUS	n/a	ON/OFF	DEMAND CONTROL VENTILATION STATUS (CO <sub>2</sub> sensor required, accessory or factory option) Displays ON if IN CO2 value above setpoint DCV SET and OFF if below setpoint DCV SET.
	DAMPER OUT	2.0V	2.0 to 10.0V	Displays output voltage or position to the damper actuator. <sup>d</sup>
	ACT POS	n/a	0 to 100%	Displays actual position of outdoor air damper actuator
	ACT COUNT	n/a	1 to 65535	Displays number of times actuator has cycled. 1 Cycle equals accrued 180° of actuator movement in any direction
	ACTUATOR	n/a	OK/Alarm (on Alarm menu)	Displays Error if voltage or torque is below actuator range
EXH1 OUT	OFF	ON/OFF	EXHAUST STAGE 1 RELAY OUTPUT Output of EXH1 terminal. Displays On when damper position reaches programmed percentage setpoint. ON = 24 Vac Output; OFF = No Output.	

**Table 5 – Menu Structure<sup>a</sup> (cont)**

Menu	Parameter	Parameter Default Value	Parameter Range and Increment <sup>b</sup>	EXPANDED PARAMETER NAME Notes	
<b>STATUS (cont)</b>	EXH2 OUT	OFF	ON/OFF	EXHAUST STAGE 2 RELAY OUTPUT Output of AUX1 O terminal Displays ON when damper position reaches programmed percentage setpoint ON = 24 Vac Output, OFF = No Output; displays only if AUX1 O = EXH2	
	MECH COOL ON or HEAT STAGES ON	0	0, 1, or 2	Displays stage of mechanical cooling that is active. Displays the stage of heat pump heating that is active	
	FAN SPEED	n/a	LOW or HIGH	SUPPLY FAN SPEED Displays speed setting of fan on a 2–speed fan unit.	
	W (HEAT ON)	n/a	ON/OFF	HEAT DEMAND STATUS Displays status of heat demand on a 2–speed fan unit.	
<b>SETPOINTS</b>	MAT SET	53°F (12°C)	38 to 70°F; (3 to 21°C) increment by 1	SUPPLY AIR SETPOINT Setpoint determines where the economizer will modulate the OA damper to maintain the mixed air temperature. See Menu Note 2.	
	LOW T LOCK	32°F (0°C)	–45 to 80°F; (–43 to 27°C) increment by 1	COMPRESSOR LOW TEMPERATURE LOCKOUT Setpoint determines outdoor temperature when the mechanical cooling cannot be turned on. Commonly referred to as the Compressor lockout. At or below the setpoint the Y1–O and Y2–O will not be energized on the controller.	
	DRYBLB SET	63°F (17°C)	48 to 80°F (9 to 27°C) increment by 1	OA DRY BULB TEMPERATURE CHANGEOVER SETPOINT Setpoint determines where the economizer will assume outdoor air temperature is good for free cooling; e.g.: at 63°F (17°C), unit will economize at 62°F (16.7°C) and below and not economize at 64°F (17.8°C) and above. There is a 2°F (1.1°C) deadband. See Menu Note 3	
	ENTH CURVE	ES3	ES1, ES2, ES3, ES4, or ES5	ENTHALPY CHANGEOVER CURVE (Requires enthalpy sensor option) Enthalpy boundary “curves” for economizing using single enthalpy. See page 19 for description of enthalpy curves.	
	DCV SET	1100ppm	500 to 2000 ppm; increment by 100	DEMAND CONTROL VENTILATION SETPOINT Displays only if CO <sub>2</sub> sensor is connected. Setpoint for Demand Control Ventilation of space. Above the setpoint, the OA dampers will modulate open to bring in additional OA to maintain a space ppm level below the setpoint.	
	MIN POS	2.8 V	2 to 10 Vdc	VENTILATION MINIMUM POSITION Displays ONLY if a CO <sub>2</sub> sensor is NOT connected.	
				With 2–speed fan units MIN POS L (low speed fan) and MIN POS H (high speed fan) settings are required. Default for MIN POS L is 3.2V and MIN POS H is 2.8V.	
	VENTMAX	2.8 V	2 to 10 Vdc	DCV MAXIMUM DAMPER POSITION Displays only if a CO <sub>2</sub> sensor is connected. Used for Vbz (ventilation max cfm) setpoint. VENTMAX is the same setting as MIN POS would be if you did not have the CO <sub>2</sub> sensor.	
				100 to 9990 cfm increment by 10	If OA, MA RA and CO <sub>2</sub> sensors are connected and DCV CAL ENABLE is set to AUTO mode, the OA dampers are controlled by CFM and displays from 100 to 9990 cfm.
				2 to 10 Vdc	With 2–speed fan units VENTMAX L (low speed fan) and VENTMAX H (high speed fan) settings are required. Default for VENTMAX L is 3.2V and VENTMAX H is 2.8V.
	VENTMIN	2.25 V	2 to 10 Vdc	DCV MINIMUM DAMPER POSITION Displays only if CO <sub>2</sub> sensor is connected. Used for Va (ventilation min cfm) setpoint. This is the ventilation requirement for less than maximum occupancy of the space.	
100 to 9990 cfm increment by 10				If OA, MA RA and CO <sub>2</sub> sensors are connected and DCV CAL ENABLE is set to AUTO mode, the OA dampers are controlled by CFM and displays from 100 to 9990 cfm.	
2 to 10 Vdc				With 2–speed fan units VENTMIN L (low speed fan) and VENTMIN H (high speed fan) settings are required. Default for VENTMIN L is 2.5V and VENTMIN H is 2.25V.	
EXH1 SET	50%	0 to 100%; Increment by 1	EXHAUST FAN STAGE 1 SETPOINT Setpoint for OA damper position when exhaust fan 1 is powered by the economizer. With 2–speed fan units Exh1 L (low speed fan) and Exh1 H (high speed fan) settings are required. Default for Exh1 L is 65% and Exh1 H is 50%		

**Table 5 – Menu Structure<sup>a</sup> (cont)**

Menu	Parameter	Parameter Default Value	Parameter Range and Increment <sup>b</sup>	EXPANDED PARAMETER NAME Notes
<b>SETPOINTS (cont)</b>	EXH2 SET	75%	0 to 100%; Increment by 1	EXHAUST FAN STAGE 2 SETPOINT Setpoint for OA damper position when exhaust fan 2 is powered by the economizer. Only used when AUX1 O is set to EHX2. With 2–speed fan units Exh2 L (low speed fan) and Exh2 H (high speed fan) settings are required. Default for Exh2 L is 80% and Exh2 H is 75%
<b>SYSTEM SETUP</b>	INSTALL	01/01/10		Display order = MM/DD/YY Setting order = DD, MM, then YY.
	UNITS DEG	°F	°F or °C	Sets economizer controller in degrees Fahrenheit or Celsius.
	EQUIPMENT	CONV	Conventional or HP	CONV = conventional; HP O/B = Enable Heat Pump mode. Use AUX2 I for Heat Pump input from thermostat or controller. See Menu Note 4
	AUX2 IN	n/a	Shutdown (SD) Heat (W1) HP (O) HP (B)	In CONV mode: SD = Enables configuration of shutdown (default); W = Informs controller that system is in heating mode. <b>NOTE: If using 2–speed fan mode, you must program CONV mode for W. Shutdown is not available in 2–speed fan mode.</b> <b>See Menu Note 4.</b> In HP O/B mode: HP(O) = energize heat pump on Cool (default); HP(B) = energize heat pump on Heat.
	FAN SPEED	1speed	1 speed/ 2 speed	Sets economizer controller for operation of 1 speed or 2 speed supply fan. The controller does not control the fan but positions the OA and RA dampers to the heating or cooling mode. See page 23 for modes and position. <b>NOTE: 2–speed fan option also needs Heat (W1) programmed in AUX 2 In. See Menu Note 4.</b>
	FAN CFM	5000cfm	100 to 15000 cfm; increment by 100	UNIT DESIGN AIRFLOW (CFM) Enter ONLY if using DCVCAL ENA = AUTO The value is found the nameplate label for the specific RTU.
	AUX1 OUT	NONE	NONE EXH2 SYS	Select OUTPUT for AUX1 O relay NONE = not configured (output is not used) EXH2 = second damper position 24 Vac out for second exhaust fan SYS = use output as an alarm signal
	OCC	INPUT	INPUT or ALWAYS	OCCUPIED MODE BY EXTERNAL SIGNAL When using a setback thermostat with occupancy out (24 Vac), the 24 Vac is input "INPUT" to the OCC terminal. If no occupancy output from the thermostat then change program to "ALWAYS" OR add a jumper from terminal R to OCC terminal. See Menu Note 2.
FACTORY DEFAULT	NO	NO or YES	Resets all set points to factory defaults when set to YES. LCD will briefly flash YES and change to NO but all parameters will change to the factory default values. <b>NOTE: RECHECK AUX2 IN and FANTYPE for required 2–speed values.</b>	
<b>ADVANCED SETUP</b>	MA LO SET	45°F (7°C)	35 to 65°F; (2 to 18°C) Incremented by 1°	SUPPLY AIR TEMPERATURE LOW LIMIT Temperature to activate Freeze Protection (close damper and alarm if temperature falls below setup value)
	FREEZE POS	CLO	CLO or MIN	FREEZE PROTECTION DAMPER POSITION Damper position when freeze protection is active CLO = closed MIN = MIN POS or VENTMAX
	CO2 ZERO	0ppm	0 to 500 ppm; Increment by 10	CO <sub>2</sub> ppm level to match CO <sub>2</sub> sensor start level.
	CO2 SPAN	2000ppm	1000 to 3000 ppm; Increment by 50	CO <sub>2</sub> ppm span to match CO <sub>2</sub> sensor. e.g.; 500–1500 sensor output would be 500 CO <sub>2</sub> zero and 1000 CO <sub>2</sub> span.
	STG3 DLY	2.0h	0 min, 5 min, 15 min, then 15 min intervals. Up to 4 h or OFF	COOLING STAGE 3 DELAY Delay after stage 2 for cool has been active. Turns on 2nd stage of mechanical cooling when economizer is 1st stage call and mechanical cooling is 2nd stage call. Allows three stages of cooling, 1 economizer and 2 mechanical. OFF = no Stage 3 cooling.
	SD DMPR POS	CLO	CLO or OPN	Indicates shutdown signal from space thermostat or unitary controller. When controller receives 24 Vac input on the SD terminal in conventional mode, the OA damper will open if programmed for OPN and OA damper will close if programmed for CLO. All other controls, e.g., Y1–O, Y2–O, EXH1, etc. will shut off. <b>NOTE: Function NOT AVAILABLE with 2–speed mode</b>
	DA LO ALM	45°F (7°C)	NONE 70 to 180°F; (2 to 18°C) Incremented by 5°	Used for alarm for when the DA air temperature is too low. Set lower range of alarm, below this temperature the alarm will show on the display.

**Table 5 – Menu Structure<sup>a</sup> (cont)**

Menu	Parameter	Parameter Default Value	Parameter Range and Increment <sup>b</sup>	EXPANDED PARAMETER NAME Notes
<b>ADVANCED SETUP (cont)</b>	DA HI ALM	80°F (27°C)	NONE 35 to 65°F; (21 to 82°C) Incremented by 5°	Used for alarm for when the DA air temperature is too high. Set high range of alarm, above this temperature the alarm will show on the display
	DCVCAL ENA	MAN	MAN (manual) AUTO	Turns on the DCV automatic control of the dampers. Resets ventilation based on the RA, OA and MA sensor conditions. Requires all sensors (RA, OA, MA and CO <sub>2</sub> ). <b>NOTE: This operation is not operable with a 2-speed fan unit.</b>
	MAT T CAL	0.0°F (or C)	+/-2.5°F (+/-1.4°C)	SUPPLY AIR TEMPERATURE CALIBRATION Allows for the operator to adjust for an out of calibration supply air temperature (SAT) sensor
	OAS T CAL	1.0°F (or C)	+/-2.5°F (+/-1.4°C)	OUTSIDE AIR TEMPERATURE CALIBRATION Allows for the operator to adjust for an out of calibration outside air temperature (OAT) sensor
	OAS H CAL	0% RH	+/-10% RH	COURTSIDE AIR HUMIDITY CALIBRATION Allows for the operator to adjust for an out of outside air enthalpy sensor
	RA T CAL	0.0°F (or C)	+/-2.5°F (+/-1.4°C)	RETURN AIR TEMPERATURE CALIBRATION Allows for the operator to adjust for an out of calibration return air temperature (RA) sensor
	RA H CAL	0% RH	+/-10% RH	RETURN AIR HUMIDITY CALIBRATION Allows for the operator to adjust for an out of calibration return air enthalpy sensor
	DA T CAL	0.0°F (or C)	+/-2.5°F (+/-1.4°C)	DISCHARGE AIR TEMPERATURE CALIBRATION Allows for the operator to adjust for an out of calibration discharge air temperature (DAT) sensor
	2SP FAN DELAY	5 Minutes	0 to 20 minutes in 1 minute increments	TIME DELAY ON 2 <sup>nd</sup> STAGE ECONOMIZING When in economizing mode this is the delay for the high speed fan to try to satisfy the call for second stage cooling before the first stage mechanical cooling is enabled.
<b>CHECKOUT<sup>e</sup></b>	DAMPER MINIMUM POSITION	n/a	n/a	The checkout for the damper minimum positions is based on the system. See Table 6.
	DAMPER OPEN	n/a	n/a	Positions damper to the full open position. Exhaust fan contacts enable during the DAMPER OPEN test. Make sure you pause in this mode to allow for exhaust contacts to energize due to the delay in the system.
	DAMPER CLOSE	n/a	n/a	Positions damper to the fully closed position
	CONNECT Y1-O	n/a	n/a	Closes the Y1-O relay (Y1-O). See <b>CAUTION</b> on page 20.
	CONNECT Y2-O	n/a	n/a	Closes the Y2-O relay (Y2-O) See <b>CAUTION</b> on page 20.
	CONNECT AUX1-O	n/a	n/a	Energizes the AUX1-O output. If AUX1-O setting is: • NONE – not action taken • SYS – 24 Vac out. Issues a system alarm.
	CONNECT EXH1	n/a	n/a	Closes the power exhaust fan 1 relay (EXH1)

**Table 5 – Menu Structure<sup>a</sup> (cont)**

Menu	Parameter	Parameter Default Value	Parameter Range and Increment <sup>b</sup>	EXPANDED PARAMETER NAME Notes
ALARMS(#)				Alarms display only when they are active. The menu title "ALARMS(#)" includes the number of active alarms in parenthesis ( ). When using S–bus sensors, "SYLK" will appear on the screen, and when using 20k OA temperature sensors, "SENS T" will appear on the screen.
	MA T SENS ERR	n/a	n/a	SUPPLY AIR TEMPERATURE SENSOR ERROR Supply air sensor has failed or become disconnected – check wiring then replace sensor if the alarm continues
	CO2 SENS ERR	n/a	n/a	CO <sub>2</sub> SENSOR ERROR CO <sub>2</sub> sensor has failed, gone out of range or become disconnected – check wiring then replace sensor if the alarm continues
	OA SYLK T ERR	n/a	n/a	OUTSIDE AIR S–BUS SENSOR ERROR Outside air enthalpy sensor has failed or become disconnected – check wiring then replace sensor if the alarm continues
	OA SYLK H ERR	n/a	n/a	
	RA SYLK T ERR	n/a	n/a	RETURN AIR S–BUS SENSOR ERROR Return air enthalpy sensor has failed or become disconnected – check wiring then replace sensor if the alarm continues
	RA SYLK H ERR	n/a	n/a	
	DA SYLK T ERR	n/a	n/a	DISCHARGE AIR S–BUS SENSOR ERROR Discharge air sensor has failed or become disconnected – check wiring then replace sensor if the alarm continues
	OA SENS T ERR	n/a	n/a	OUTSIDE AIR TEMPERATURE SENSOR ERROR Outside air temperature sensor has failed or become disconnected – check wiring then replace sensor if the alarm continues
	ACT ERROR	n/a	n/a	ACTUATOR ERROR Actuator has failed or become disconnected – check for stall, over voltage, under voltage and actuator count. Replace actuator if damper is moveable and supply voltage is between 21.6 V and 26.4 V. Check actuator count on STATUS menu.
	FREEZE ALARM	n/a	n/a	Check if outdoor temperature is below the LOW Temp Lockout on setpoint menu. Check if Mixed air temperature on STATUS menu is below the Lo Setpoint on Advanced setup menu. When conditions are back in normal range then the alarm will go away.
	SHUTDOWN ACTIVE	n/a	n/a	AUX2 IN is programmed for SHUTDOWN and 24 V has been applied to AUX 2IN terminal
	DMP CAL RUNNING	n/a	n/a	DAMPER CALIBRATION ROUTINE RUNNING If DCV Auto enable has been programmed, when the w7220 is completing a calibration on the dampers, this alarm will display. Wait until the calibration is completed and the alarm will go away. Must have OA, MA and RA sensors for DCV calibration; set up is in the Advanced setup menu.
	DA SENS ALM	n/a	n/a	DISCHARGE AIR TEMPERATURE SENSOR ALARM Discharge air temperature is out of the range set in the ADVANCED SETUP Menu. Check the temperature of the discharge air.
	SYS ALARM	n/a	n/a	When AUX1–O is set to SYS and there is any alarm (e.g., failed sensors, etc.), the AUX1–O terminal has 24 Vac out.
	ACT UNDER V	n/a	n/a	ACTUATOR VOLTAGE LOW Voltage received at actuator is below expected range
	ACT OVER V	n/a	n/a	ACTUATOR VOLTAGE HIGH Voltage received at actuator is above expected range
	ACT STALLED	n/a	n/a	ACTUATOR STALLED Actuator stopped before reaching commanded position

<sup>a</sup> Table 5 illustrates the complete hierarchy, your menu parameters may be different depending on your configuration.

For example if you do not have a DCV (CO<sub>2</sub>) sensor, then none of the DCV parameters appear.

<sup>b</sup> When values are displayed, pressing and holding the ▲ or ▼ button causes the display to automatically increment.

<sup>c</sup> n/a = not applicable

<sup>d</sup> When used with communicating actuator the damper out is reported in XX.X% open verses XX.X Vdc.

<sup>e</sup> After 10 minutes without a command or mode change, the controller will change to normal operation.

**Menu Notes**

1 **STATUS –> OCCUPIED** – The factory-standard Occupancy signal originates with a thermostat or other controller call for indoor fan operation at CTB terminal G. This signal passes through the Central Terminal Board's OCCUPIED jumper JMP1 to the ECONO connector and to the W7220's OCC input terminal. An external timeclock or relay is required to implement an Occupancy schedule on the economizer damper position.

2 **STATUS -> MA TEMP, SETPOINTS -> MAT SET** – The W7220 menu parameters and labels include designations MA, MAT and Mixed Air for the economizer cooling control sensor. On these rooftop units, the economizer control sensor is located downstream of the evaporator/indoor coil in the supply fan section where this sensor is designated as Supply Air Temperature (SAT) sensor.

3 **SETPOINTS -> DRYBLB SET** – This point is not displayed if a Return Air (differential) temperature sensor or an Outdoor Air enthalpy sensor is connected.

4 **SYSTEM SETUP** parameters must be configured as noted for 2-Speed unit operation:

**EQUIPMENT** = CONV

**AUX2 I** = W

**FAN TYPE** = 2SPEED

**Table 6 – Damper Minimum Position Settings and Readings on Checkout Menu**

Fan Speed	Demand Control Ventilation (CO2 Sensor)	Setpoints	Checkout
1	NO	MIN POS	VMAX–HS
1	NO	N/A	N/A
2	NO	MIN POS H	VMAX–HS
2	NO	MIN POS L	VMAX–LS
1	YES	VENT MIN	VMIN–HS
1	YES	VENT MAX	VMAX–HS
2	YES	VENT MIN H	VMIN–HS
2	YES	VENT MAX H	VMAX–LS
2	YES	VENT MINL	N/A
2	YES	VENT MAX L	N/A

## SEQUENCE OF OPERATION

**Table 7 – Dry Bulb Operation No DCV (CO<sub>2</sub> Sensor) – 1 Speed Fan**

Demand Control Ventilation (DCV)	Outside Air – Good to economize?	Y1-I	Y2-I	Fan Speed	Y1-O	Y2-O	Occupied	Unoccupied
None	No	Off	Off	High	0-v/Off	0-v/Off	MIN POS	Closed
		On	Off	High	24-v/On	0-v/Off	MIN POS	Closed
		On	On	High	24-v/On	24-v/On	MIN POS	Closed
None	Yes	Off	Off	High	0-v/Off	0-v/Off	MIN POS	Closed
		On	Off	High	0-v/Off	0-v/Off	MIN POS to Full- Open	Closed to Full-Open
		On	On	High	24-v/On	0-v/Off <sup>a</sup>	MIN POS to Full- Open	Closed to Full-Open

<sup>a</sup> With stage 3 delay (STG3 DLY) in Advanced setup menu can turn on 2nd stage of mechanical cooling Y2 –O after the delay if the call for Y1–I and Y2–I have not been satisfied.

**Table 8 – Dry Bulb Operation With DCV (CO<sub>2</sub> Sensor) – 1 Speed Fan**

Demand Control Ventilation (DCV)	Outside Air – Good to economize?	Y1-I	Y2-I	Fan Speed	Y1-O	Y2-O	Occupied	Unoccupied
Below CO <sub>2</sub> set	No	Off	Off	High	0-v/Off	0-v/Off	VENTMIN	Closed
		On	Off	High	24-v/On	0-v/Off	VENTMIN	Closed
		On	On	High	24-v/On	24-v/On	VENTMIN	Closed
	Yes	Off	Off	High	0-v/Off	0-v/Off	VENTMIN	Closed
		On	Off	High	0-v/Off	0-v/Off	VENTMIN to Full- Open	Closed to Full-Open
		On	On	High	24-v/On	0-v/Off <sup>a</sup>	VENTMIN to Full- Open	Closed to Full-Open
Above CO <sub>2</sub> set	No	Off	Off	High	0-v/Off	0-v/Off	VENTMIN to VENTMAX	Closed
		On	Off	High	24-v/On	0-v/Off	VENTMIN to VENTMAX	Closed
		On	On	High	24-v/On	24-v/On	VENTMIN to VENTMAX	Closed
	Yes	Off	Off	High	0-v/Off	0-v/Off	VENTMIN to VENTMAX	Closed
		On	Off	High	0-v/Off	0-v/Off	VENTMIN to Full- Open	Closed to Full-Open
		On	On	High	24-v/On	0-v/Off <sup>a</sup>	VENTMIN to Full- Open	Closed to Full-Open

<sup>a</sup> With stage 3 delay (STG3 DLY) in Advanced setup menu can turn on 2nd stage of mechanical cooling Y2 –O after the delay if the call for Y1–I and Y2–I have not been satisfied.

**Table 9 – Enthalpy Operation No DCV (CO<sub>2</sub> Sensor) – 1 Speed Fan**

Demand Control Ventilation (DCV)	Outside Air – Good to economize?	Y1-I	Y2-I	Fan Speed	Y1-O	Y2-O	Occupied	Unoccupied
None	No	Off	Off	High	0-v/Off	0-v/Off	MIN POS	Closed
		On	Off	High	24-v/On	0-v/Off	MIN POS	Closed
		On	On	High	24-v/On	24-v/On	MIN POS	Closed
None	Yes	Off	Off	High	0-v/Off	0-v/Off	MIN POS	Closed
		On	Off	High	0-v/Off	0-v/Off	MIN POS to Full- Open	Closed to Full-Open
		On	On	High	24-v/On	0-v/Off <sup>a</sup>	MIN POS to Full- Open	Closed to Full-Open

<sup>a</sup> With stage 3 delay (STG3 DLY) in Advanced setup menu can turn on 2nd stage of mechanical cooling Y2 –O after the delay if the call for Y1–I and Y2–I have not been satisfied.

**Table 10 – Enthalpy Operation No DCV (CO<sub>2</sub> Sensor) – 1 Speed Fan**

Demand Control Ventilation (DCV)	Outside Air – Good to economize?	Y1-I	Y2-I	Fan Speed	Y1-O	Y2-O	Occupied	Unoccupied
Below set	No	Off	Off	High	0-v/Off	0-v/Off	VENTMIN	Closed
		On	Off	High	24-v/On	0-v/Off	VENTMIN	Closed
		On	On	High	24-v/On	24-v/On	VENTMIN	Closed
	Yes	Off	Off	High	0-v/Off	0-v/Off	VENTMIN	Closed
		On	Off	High	0-v/Off	0-v/Off	VENTMIN to Full- Open	Closed to Full-Open
		On	On	High	24-v/On	0-v/Off <sup>a</sup>	VENTMIN to Full- Open	Closed to Full-Open
Above set	No	Off	Off	High	0-v/Off	0-v/Off	VENTMIN to VENTMAX	Closed
		On	Off	High	24-v/On	0-v/Off	VENTMIN L to VENTMAX	Closed
		On	On	High	24-v/On	24-v/On	VENTMIN H to VENTMAX	Closed
	Yes	Off	Off	High	0-v/Off	0-v/Off	VENTMIN L to VENTMAX	Closed
		On	Off	High	0-v/Off	0-v/Off	VENTMIN to Full- Open	Closed to Full-Open
		On	On	High	DELAY <sup>b</sup> 24-v/On	0-v/Off <sup>a</sup>	VENTMIN to Full- Open	Closed to Full-Open

<sup>a</sup> With stage 3 delay (STG3 DLY) in Advanced setup menu can turn on 2nd stage of mechanical cooling Y2 –O after the delay if the call for Y1–I and Y2–I have not been satisfied.

<sup>b</sup> With 2SP FAN DELAY (Advanced Setup Menu) when in the economizing mode there is a delay for the high speed fan to try to satisfy the call for second stage cooling by turning on the fan to high and opening the OA damper 100% before the first stage mechanical cooling is enabled.

**Table 11 – Dry Bulb Operation No DCV (CO<sub>2</sub> Sensor) – 2 Speed Fan**

Demand Control Ventilation (DCV)	Outside Air – Good to economize?	Y1-I	Y2-I	Fan Speed	Y1-O	Y2-O	Occupied	Unoccupied
None	No	Off	Off	Low	0-v/Off	0-v/Off	MIN POS L	Closed
		On	Off	Low	24-v/On	0-v/Off	MIN POS L	Closed
		On	On	High	24-v/On	24-v/On	MIN POS H	Closed
None	Yes	Off	Off	Low	0-v/Off	0-v/Off	MIN POS L	Closed
		On	Off	Low	0-v/Off	0-v/Off	MIN POS L to Full- Open	Closed to Full-Open
		On	On	High	DELAY <sup>b</sup> 24-v/On	0-v/Off <sup>a</sup>	MIN POS H to Full- Open	Closed to Full-Open

<sup>a</sup> With stage 3 delay (STG3 DLY) in Advanced setup menu can turn on 2nd stage of mechanical cooling Y2 –O after the delay if the call for Y1 –I and Y2 –I have not been satisfied.

<sup>b</sup> With 2SP FAN DELAY (Advanced Setup Menu) when in the economizing mode there is a delay for the high speed fan to try to satisfy the call for second stage cooling by turning on the fan to high and opening the OA damper 100% before the first stage mechanical cooling is enabled.

**Table 12 – Dry Bulb Operation With DCV (CO<sub>2</sub> Sensor) – 2 Speed Fan**

Demand Control Ventilation (DCV)	Outside Air – Good to economize?	Y1-I	Y2-I	Fan Speed	Y1-O	Y2-O	Occupied	Unoccupied
Below set	No	Off	Off	Low	0-v/Off	0-v/Off	VENTMIN L	Closed
		On	Off	Low	24-v/On	0-v/Off	VENTMIN L	Closed
		On	On	High	24-v/On	24-v/On	VENTMIN H	Closed
	Yes	Off	Off	Low	0-v/Off	0-v/Off	VENTMIN L	Closed
		On	Off	Low	0-v/Off	0-v/Off	VENTMIN L to Full- Open	Closed to Full-Open
		On	On	High	24-v/On	0-v/Off <sup>a</sup>	VENTMIN H to Full- Open	Closed to Full-Open
Above set	No	Off	Off	Low	0-v/Off	0-v/Off	VENTMIN L to VENTMAX	Closed
		On	Off	Low	24-v/On	0-v/Off	VENTMIN L to VENTMAX	Closed
		On	On	High	24-v/On	24-v/On	VENTMIN H to VENTMAX	Closed
	Yes	Off	Off	Low	0-v/Off	0-v/Off	VENTMIN L to VENTMAX	Closed
		On	Off	Low	0-v/Off	0-v/Off	VENTMIN L to Full- Open	Closed to Full-Open
		On	On	High	DELAY <sup>b</sup> 24-v/On	0-v/Off <sup>a</sup>	VENTMIN H to Full- Open	Closed to Full-Open

<sup>a</sup> With stage 3 delay (STG3 DLY) in Advanced setup menu can turn on 2nd stage of mechanical cooling Y2 –O after the delay if the call for Y1 –I and Y2 –I have not been satisfied.

<sup>b</sup> With 2SP FAN DELAY (Advanced Setup Menu) when in the economizing mode there is a delay for the high speed fan to try to satisfy the call for second stage cooling by turning on the fan to high and opening the OA damper 100% before the first stage mechanical cooling is enabled.

**Table 13 – Enthalpy Operation No DCV (CO<sub>2</sub> Sensor) – 2 Speed Fan**

Demand Control Ventilation (DCV)	Outside Air – Good to economize?	Y1-I	Y2-I	Fan Speed	Y1-O	Y2-O	Occupied	Unoccupied
NO CO <sub>2</sub> SENSOR	No	Off	Off	Low	0-v/Off	0-v/Off	MIN POS L	Closed
		On	Off	Low	24-v/On	0-v/Off	MIN POS L	Closed
		On	On	High	24-v/On	24-v/On	MIN POS H	Closed
	Yes	Off	Off	Low	0-v/Off	0-v/Off	MIN POS L	Closed
		On	Off	Low	0-v/Off	0-v/Off	MIN POS L to Full- Open	Closed to Full-Open
		On	On	High	DELAY <sup>b</sup> 24-v/On	0-v/Off <sup>a</sup>	MIN POS H to Full- Open	Closed to Full-Open

<sup>a</sup> With stage 3 delay (STG3 DLY) in Advanced setup menu can turn on 2nd stage of mechanical cooling Y2 –O after the delay if the call for Y1 –I and Y2 –I have not been satisfied.

<sup>b</sup> With 2SP FAN DELAY (Advanced Setup Menu) when in the economizing mode there is a delay for the high speed fan to try to satisfy the call for second stage cooling by turning on the fan to high and opening the OA damper 100% before the first stage mechanical cooling is enabled.

**Table 14 – Enthalpy Operation With DCV (CO<sub>2</sub> Sensor) – 2 Speed Fan**

Demand Control Ventilation (DCV)	Outside Air – Good to economize?	Y1-I	Y2-I	Fan Speed	Y1-O	Y2-O	Occupied	Unoccupied
Below set	No	Off	Off	Low	0-v/Off	0-v/Off	VENTMIN L	Closed
		On	Off	Low	24-v/On	0-v/Off	VENTMIN L	Closed
		On	On	High	24-v/On	24-v/On	VENTMIN H	Closed
	Yes	Off	Off	Low	0-v/Off	0-v/Off	VENTMIN L	Closed
		On	Off	Low	0-v/Off	0-v/Off	VENTMIN L to Full- Open	Closed to Full-Open
		On	On	High	24-v/On	0-v/Off <sup>a</sup>	VENTMIN H to Full- Open	Closed to Full-Open
Above set	No	Off	Off	Low	0-v/Off	0-v/Off	VENTMIN L to VENTMAX	Closed
		On	Off	Low	24-v/On	0-v/Off	VENTMIN L to VENTMAX	Closed
		On	On	High	24-v/On	24-v/On	VENTMIN H to VENTMAX	Closed
	Yes	Off	Off	Low	0-v/Off	0-v/Off	VENTMIN L to VENTMAX	Closed
		On	Off	Low	0-v/Off	0-v/Off	VENTMIN L to Full- Open	Closed to Full-Open
		On	On	High	DELAY <sup>b</sup> 24-v/On	0-v/Off <sup>a</sup>	VENTMIN H to Full- Open	Closed to Full-Open

<sup>a</sup> With stage 3 delay (STG3 DLY) in Advanced setup menu can turn on 2nd stage of mechanical cooling Y2 –O after the delay if the call for Y1 –I and Y2 –I have not been satisfied.

<sup>b</sup> With 2SP FAN DELAY (Advanced Setup Menu) when in the economizing mode there is a delay for the high speed fan to try to satisfy the call for second stage cooling by turning on the fan to high and opening the OA damper 100% before the first stage mechanical cooling is enabled.

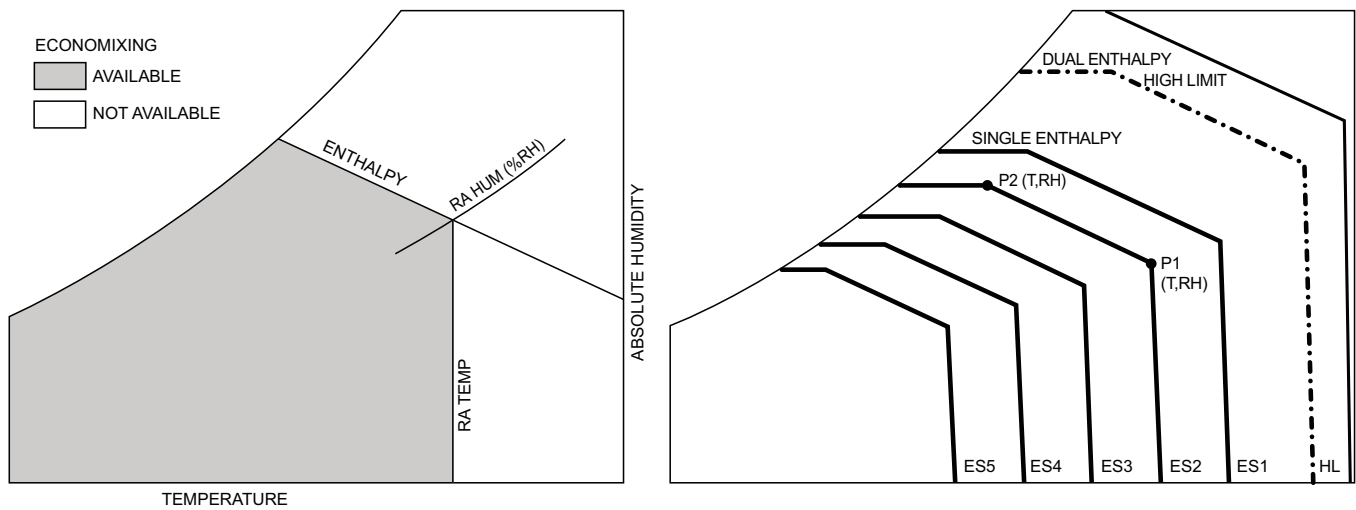

**Fig. 8 – Single Enthalpy Curve and Boundaries**

C12015

**Table 15 – Single Enthalpy and Dual Enthalpy High Limit Curves (EN Units)**

Enthalpy Curve	Temp. Dry-Bulb (°F)	Temp. Dewpoint (°F)	Enthalpy (btu/lb/da)	Point P1		Point P2	
				Temp. (°F)	Humidity %RH	Temp. (°F)	Humidity %RH
ES1	80.0	60.0	28.0	80.0	36.8	66.3	80.1
ES2	75.0	57.0	26.0	75.0	39.6	63.3	80.0
ES3	70.0	54.0	24.0	70.0	42.3	59.7	81.4
ES4	65.0	51.0	22.0	65.0	44.8	55.7	84.2
ES5	60.0	48.0	20.0	60.0	46.9	51.3	88.5
HL	86.0	66.0	32.4	86.0	38.9	72.4	80.3

## Enthalpy Settings

When the OA temperature, enthalpy and dew point are below the respective setpoints, the Outdoor Air can be used for economizing. Fig. 8 shows the new single enthalpy boundaries in the W7220. There are 5 boundaries (setpoints ES1 through ES5), which are defined by dry bulb temperature, enthalpy and dew point.

Refer to Table 15 for ENTH CURVE setpoint values.

The W7220 calculates the enthalpy and dew point using the OA temperature and humidity input from the OA enthalpy sensor. When the OA temperature, OA humidity and OA dew point are all below the selected boundary, the economizer sets the economizing mode to YES, economizing is available.

When all of the OA conditions are above the selected boundary, the conditions are not good to economize and the mode is set to NO.

Fig. 8 shows the 5 current boundaries. There is also a high limit boundary for differential enthalpy. The high limit boundary is ES1 when there are no stages of mechanical cooling energized and HL (high limit) when a compressor stage is energized.

Table 15 provides the values for each boundary limit.

## Two-Speed Fan Operation

The W7220 controller has the capability to work with a system using a 2-speed supply fan. The W7220 does not control the supply directly but uses the following input status to determine the speed of the supply fan and controls the OA damper to the required position.

State	Fan Speed
OCC	Low
Y1	Low
Y2	High
W	High

The W (heating mode) is not controlled by the W7220 but it requires the status to know where to position the OA damper for minimum position for the fan speed.

The 2 speed fan delay is available when the system is programmed for 2 speed fan (in the System Setup menu item). The 2 speed fan delay is defaulted to 5 minutes and can be changed in the Advanced Setup menu item. When the unit has a call for Y1 In and in the free cooling mode and there is a call for Y2 In, the 2-speed fan delay starts and the OA damper will modulate 100% open, the supply fan should be set to high speed by the unit controller. After the delay one of two actions will happen:

- The Y2 In call will be satisfied with the damper 100% open and fan on high speed and the call will turn off

OR

- If the call for additional cooling in the space has not been satisfied then the first stage of mechanical cooling will be enabled through Y1 Out or Y2 Out.

## CHECKOUT

Inspect all wiring connections at the Economizer module's terminals, and verify compliance with the installation wiring diagrams.

For checkout, review the Status of each configured parameter and perform the Checkout tests.

**NOTE:** See "Interface Overview" on page 8. for information about menu navigation and use of the keypad.

**⚠ WARNING**

**ELECTRICAL SHOCK HAZARD**

Failure to follow this warning could cause personal injury, death or property damage.

Before performing service or maintenance operations on unit, always turn off main power switch to unit and install lock(s) and lockout tag(s). Unit may have more than one power switch. Ensure electrical service to rooftop unit agrees with voltage and amperage listed on the unit rating plate.

If any wiring changes are required, first be sure to remove power from the Economizer module before starting work. Pay particular attention to verifying the power connection (24 Vac).

### Power Up

After the W7220 module is mounted and wired, apply power.

### Initial Menu Display

On initial start up, **Honeywell** displays on the first line and **Economizer W7220** on the second line. After a brief pause, the revision of the software appears on the first line and the second line will be blank.

## Power Loss (Outage or Brownout)

All setpoints and advanced settings are restored<sup>a</sup> after any power loss or interruption.

<sup>a</sup> All settings are stored in non-volatile flash memory.

## Status

Use the Status menu (see Table 5) to check the parameter values for the various devices and sensors configured.

**NOTE:** See "Interface Overview" on page 8. for information about menu navigation and use of the keypad.

## Checkout Tests

Use the Checkout menu (on page 13) to test the damper operation and any configured outputs. Only items that are configured are shown in the Checkout menu.

**NOTE:** See "Interface Overview" on page 8. for information about menu navigation and use of the keypad.

To perform a Checkout test:

1. Scroll to the desired test in the Checkout menu using the the ▲ and ▼ buttons.
2. Press the ↵ button to select the item.
3. RUN? appears.
4. Press the ↵ button to start the test.
5. The unit pauses and then displays IN PROGRESS.
6. When the test is complete, DONE appears.
7. When all desired parameters have been tested, press the ⏴ (Menu up) button to end the test.

The Checkout tests can all be performed at the time of installation or at any time during the operation of the system as a test that the system is operable.

**⚠ CAUTION**

**EQUIPMENT DAMAGE HAZARD**

Failure to follow this caution may result in equipment damage.

Be sure to allow enough time for compressor startup and shutdown between checkout tests so that you do not short-cycle the compressors.

# TROUBLESHOOTING

## Alarms

The Economizer module provides alarm messages that display on the 2-line LCD.

**NOTE:** Upon power up, the module waits 60 minutes before checking for alarms. This allows time for all the configured devices (e.g. sensors, actuator) to become operational. The exception is the SAT sensor which will alarm immediately.



If one or more alarms are present and there has been no keypad activity for at least 5 minutes, the Alarms menu displays and cycles through the active alarms.

You can also navigate to the Alarms menu at any time.

## Clearing Alarms

Once the alarm has been identified and the cause has been removed (e.g. replaced faulty sensor), the alarm can be cleared from the display.

To clear an alarm, perform the following:

1. Navigate to the desired alarm.
2. Press the  button.
3. ERASE? displays.
4. Press the  button.
5. ALARM ERASED displays.
6. Press the  (Menu up/Exit) button to complete the action and return to the previous menu.

**NOTE:** If the alarm still exists after you clear it, it is redisplayed within 5 seconds.