

# PGE SERIES

7-<sup>1</sup>/<sub>2</sub> to 12-<sup>1</sup>/<sub>2</sub> Ton

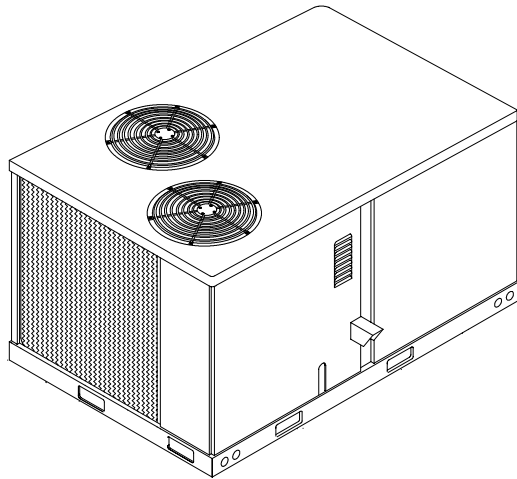

**PGE090, 120, 150**

## Commercial Package Gas/Electric Units

### Meets Ashrae 90.1 Standards

#### FEATURES:

- Exclusive integrated gas control board with diagnostics
- Induced-draft fan for gas combustion
- Tubular, dimpled heat exchangers
- Pre-painted galvanized steel cabinet for long life and quality appearance
- Commercial strength base rails with built-in rigging capability
- Convertible design for vertical or horizontal supply/return
- Non-corrosive, sloped condensate drain pan, meets ASHRAE 62
- Two-inch return-air filters
- High and low (loss-of-charge) pressure switches and freestat
- Direct-spark ignition systems
- Refrigerant filter drier
- Part load operation using two stages of cooling
- Quiet and efficient operation is provided by belt driven evaporator fans
- Thru-the-bottom utility connection capability allow power, control wiring, and gas to be routed through unit base pan, minimizing roof penetrations.
- Warranty: 10 year Heat Exchanger, 5 year compressor, 1 year parts



RESIDENTIAL AND COMMERCIAL SYSTEMS • SPLIT SYSTEMS • PACKAGED AIR CONDITIONERS • COMBINATION GAS / ELECTRIC UNITS • HEAT PUMPS • AIR HANDLERS • MANUFACTURED HOME AIR CONDITIONERS • GAS, OIL AND ELECTRIC FURNACES

International Comfort Products  
650 Heil-Quaker Avenue, Lewisburg, TN 37091

509 56 2101 05

6/23/03

# Table of Contents

	Page
Features/Benefits .....	1
Model Number Nomenclature .....	2
Unit Specifications .....	3-4
Dimensions .....	5
Performance Data .....	6-11
Typical Installation .....	12
Accessories .....	13-16
Controls .....	17
Guide Specs .....	18

MODEL NUMBER IDENTIFICATION GUIDE							
<b>MODEL NUMBER</b>	P	G	E	090	H	224	A
<b>PRODUCT FAMILY</b> Package Units						Sales Code	
<b>TYPE</b> H= Heat Pump A = Air Conditioner	G = Gas/Electric			<b>GAS HEATING OPTIONS (BTUH)</b> 224 = 224,000    250 = 250,000			
<b>DESIGN SERIES</b>					<b>VOLTAGE / PHASE / HERTZ</b> H = 208/230-3-60 L = 460-3-60    S = 575-3-60		
				<b>COOLING CAPACITY (NOMINAL BTUH)</b> 090 = 7-1/2    120 = 10 Ton 150 = 12-1/2 Ton			



UNIT SPECIFICATIONS (Legend on Next Page)				MODELS					
COOLING	PGE090H	PGE090L	PGE090S	PGE120H	PGE120L	PGE120S	PGE150H	PGE150L	PGE150S
ARI Rated Capacity Btuh (Net)	87,000			112,000			136,000		
Nominal Tons	7-1/2			10			12-1/2		
Standard CFM	2800			4000			4500		
EER	10.1			10.1			9.5		
IPLV	10.4			10.9			10.2		
Sound Rating (Bels)	8.7			8.8			8.7		
Unit Weight (lbs. / kg)	870 / 395			1035 / 469			1050 / 476		
ELECTRICAL	PGE090H	PGE090L	PGE090S	PGE120H	PGE120L	PGE120S	PGE150H	PGE150L	PGE150S
Volts/ 3 Phase/ 60Hertz	208/230	460	575	208/230	460	575	208/230	460	575
Voltage Range Min/Max	187 / 254	414 / 508	518 / 632	187 / 254	414 / 508	518 / 632	187 / 254	414 / 508	518 / 632
Power Supply MCA	40.1 / 40.1	18.4	14.9	44.2 / 44.2	21.8	18.9	60.6 / 60.6	29.1	23.7
Power Supply MOCP*	45 / 45	20	20	50 / 50	25	25	70 / 70	40	30
COMPRESSOR	RECIPROCATING			SCROLL			SCROLL		
Quantity...Model	2....CR46K6			2....SR582AE			2....ZR68KC		
Oil (Oz.)	42 ea			54 ea			60 ea		
RLA / LRA	14.0 / 91.0	6.4 / 42.0	5.2 / 39.0	15.8 / 130	7.9 / 64.0	6.6 / 52.0	19 / 156.0	9.0 / 70.0	7.4 / 54.0
REFRIGERANT TYPE	R-22								
Expansion Device	Fixed Orifice Metering Device								
Operating Charge....lb. oz....Circuit 1	7 - 6			7 - 3			9 - 8		
.....Circuit 2	8 - 1			7 - 13			9 - 5		
CONDENSER FAN	Propeller Type								
Nominal CFM	6400			7000			7000		
Quantity..Diameter (In.)	2...22			2...22			2...22		
Motor Hp...RPM	1/4...1100			1/4...1100			1/4...1100		
Watts Input (Total)	600			600			650		
FLA	1.4	0.7	0.7	1.4	0.7	0.7	1.4	0.7	0.7
CONDENSER COIL	Enhanced Copper Tubes, Aluminum Lanced fins								
Rows...Fin/In.	2...17			2...17			2...17		
Total Face Area (Sq. Ft.)	20.50			20.47			25.0		
EVAPORATOR COIL	Enhanced Copper Tubes, Aluminum Double Wavy Fins								
Rows...Fins/Inch	3...15			3...15			4...15		
Total Face Aea (sq. ft.)	8.9			10.0			11.1		
EVAPORATOR FAN	Centrifugal Type								
Quantity...Size (in.)	1...15 x 15			1...15 x 15			1...15 x 15		
Type Drive	Belt			Belt			Belt		
Nominal CFM	3000			4000			5000		
Max. Continuous Bhp	2.4			2.4			5.25		
FLA-208-230/460/575V	5.8/2.6/2.6			5.8/2.6/2.6			15.0/7.4/7.4		
Motor Frame Size	56			56			56		
Fan RPM Range	590-840			685-935			900-1260		
Motor Bearing	Ball			Ball			Ball		
Maximum Allowable RPM	2100			2100			2100		
Motor Pulley Pitch / Diameter Min/Max. (in.)	2.4 / 3.4			2.8 / 3.8			2.8 / 3.8		
Motor Shaft Diameter (in.)	5/8			5/8			7/8		
Fan Pulley Pitch Diam (in)	7.0			7.0			8.0		
Belt, Quantity...Type... Length (in.)	1...A...49			1...A...49			1...A...52		
Pulley Center Line Distance (in)	16.75-19.25			15.85-17.50			15.85-17.50		
Speed Change per Full Turn of Movable Pulley Flange (RPM)	50			50			60		
Pulley Max. full Turns From Closed Postion	5			5			6		
Factory Setting	5			5			5		
Factory Speed Setting RPM	590			685			960		
Fan Shaft Diam. at Pulley	1			1			1		

UNIT SPECIFICATIONS (CONT)		MODELS		
FURNACE SECTION		PGE090	PGE120	PGE150
Rollout Switch Cutout Temp (F)		195	195	195
Burner Orifice Diameter (in. .drill size)				
Natural Gas		120...31	129...30	129...30
Liquid Propane		096...41	102...38	102...38
Thermostat Heat Anticipator Setting (amps)				
208/230 v and 575v	Stage 1	14	14	14
208/230 v and 575v	Stage 2	20	20	20
460 v	Stage 1	14	14	14
460 v	Stage 2	20	20	20
Gas Input (Btuh)				
Stage 2 / Stage 1		224,000 / 180,000	250,000 / 200,000	250,000 / 200,000
Output Capacity (Btuh)		179,200	200,000	200,000
Efficiency (Steady State) (%) AFUE		80	80	80
Temperature Rise Range		45-75	40-70	40-70
Manifold Pressure (in. wg)				
Natural Gas		3.5	3.5	3.5
Liquid Propane		3.5	3.5	3.5
Gas Valve Quantity		1	1	1
Gas Valve Pressure Range		Psig	0.180-0.487	0.180-0.487
		in. wg	5.0-13.5	5.0-13.5
Field Gas Connection Size (in.)		3/4	3/4	3/4
<b>HIGH-PRESSURE SWITCH (psig)</b>				
Standard Compressor		450 +/- 50	450 +/- 50	450 +/- 50
Internal Relief (Differential) Cutout		428	428	428
Reset (Auto.)		320	320	320
<b>LOSS-OF-CHARGE SWITCH (psig) (LOW-PRESS.)</b>				
Cutout		7 +/- 3	7 +/- 3	7 +/- 3
Reset (Auto.)		22 +/- 7	22 +/- 7	22 +/- 7
<b>FREEZE PROTECTION THERMOSTAT (F)</b>				
Opens		30 +/- 5	30 +/- 5	30 +/- 5
Closes		45 +/- 5	45 +/- 5	45 +/- 5
<b>RETURN-AIR FILTERS (THROWAWAY)</b>				
Quantity...Size (in.)		4...16 x 20 x 2	4...20 x 20 x 2	4...20 x 20 x 2

### LEGENDS AND NOTES

Bhp = Brake Horsepower

#### Legend

Bels	-	Sound Levels
EER	-	Energy Efficiency Ratio
IPLV	-	Integrated Part Load Values
MCA	-	Minimum Circuit Amps
MOCP	-	Maximum Over-current Protection
FLA	-	Full Load Amps
LRA	-	Locked Rotor Amps
*	-	Fuse or HACR circuit breaker
RLA	-	Rated Load Amps

#### NOTES:

1. In compliance with NEC requirements for multimotor and combination load equipment (refer to NEC Articles 430 and 440), the over-current protective device for the unit shall be fuse or HACR breaker. Canadian units may be fuse or circuit breaker.

#### 2. Unbalanced 3-Phase Supply Voltage

Never operate a motor where a phase imbalance in supply voltage is greater than 2%. Use the following formula to determine the percent voltage imbalance.

% Voltage Imbalance

$$= 100 \times \frac{\text{max voltage deviation from average voltage}}{\text{average voltage}}$$

- NOTES: 1. Rated in accordance with ARI Standards 210/240, latest revision (for sizes 090 & 120) or 360, latest revision (for size 150).  
 2. ARI ratings are net values, reflecting the effects of circulating fan heat.  
 3. Ratings are based on:  
 Cooling Standard: 80F db, 67F wb indoor entering air temperature and 95F db air entering outdoor unit.  
 IPLV Standard: 80F db, 67F wb indoor entering air temperature and 80F db entering air temperature.

EXAMPLE: Supply voltage is 460-3-60.

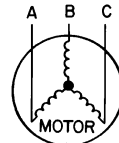

$$\begin{aligned} AB &= 452 \text{ v} & \text{Average Voltage} &= \frac{452 + 464 + 455}{3} \\ BC &= 464 \text{ v} & &= \frac{1371}{3} \\ AC &= 455 \text{ v} & &= 457 \end{aligned}$$

Determine maximum deviation from average voltage.

$$\begin{aligned} (AB) &457 - 452 = 5 \text{ V} \\ (BC) &464 - 457 = 7 \text{ V} \\ (AC) &457 - 455 = 2 \text{ V} \end{aligned}$$

Maximum deviation is 7 v.

Determine percent voltage imbalance.

$$\% \text{ Voltage Imbalance} = 100 \times \frac{7}{457} = 1.53\%$$

This amount of phase imbalance is satisfactory as it is below the maximum allowable 2%.

**IMPORTANT:** If the supply voltage phase imbalance is more than 2%, contact your local electric utility company immediately.

**BASE UNIT DIMENSIONS PGE090-150**

Unit	Total		Corner A		Corner B		Corner C		Corner D		Dim A		Dim B		Dim C	
	lb	kg	lb	kg	lb	kg	lb	kg	lb	kg	ft-in	mm	ft-in	mm	ft-in	mm
PGE090	870	395	189	86	161	73	239	109	280	127	1-2 <sup>7</sup> / <sub>8</sub>	378	3-5 <sup>5</sup> / <sub>16</sub>	1050	2-9 <sup>11</sup> / <sub>16</sub>	856
PGE120	1035	489	225	102	192	87	285	129	333	151	2-5 <sup>7</sup> / <sub>8</sub>	759	4-1 <sup>15</sup> / <sub>16</sub>	1253	3- <sup>3</sup> / <sub>8</sub>	924
PGE150	1050	476	228	103	195	88	289	131	338	153	1-2 <sup>7</sup> / <sub>8</sub>	378	4-1 <sup>15</sup> / <sub>16</sub>	1253	3- <sup>3</sup> / <sub>8</sub>	924

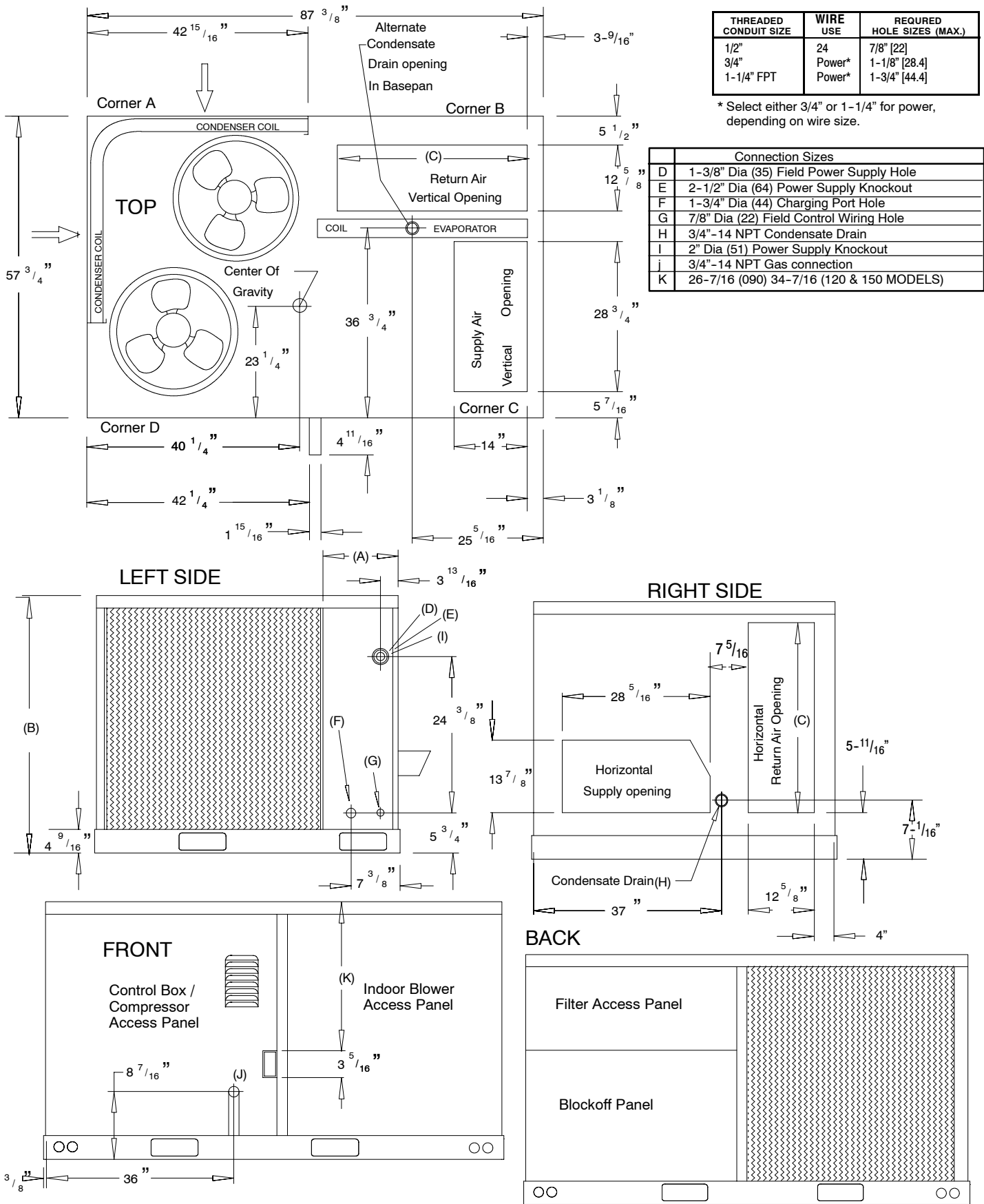

**EXPANDED PERFORMANCE DATA (COOLING) 7-1/2 Ton (GROSS Capacity)**

Airflow CFM IDB (BF)			Outdoor Ambient Temperature - Degrees F, Dry Bulb														
			75			85			95			105			115		
			Entering Indoor Air Temperature - Degrees F, Wet Bulb														
			62	67	72	62	67	72	62	67	72	62	67	72	62	67	72
80	3750 (0.14)	MBH	94.0	102.0	109.6	90.0	97.2	105.0	85.5	91.6	99.8	80.9	85.7	94.2	76.3	79.7	87.9
		S/T	0.99	0.76	0.53	1.00	0.79	0.54	1.00	0.82	0.56	1.00	0.85	0.58	1.00	0.89	0.60
		KW	6.00	6.28	6.52	6.47	6.71	6.98	6.92	7.13	7.43	7.36	7.55	7.85	7.82	7.96	8.29
	3000 (0.11)	MBH	91.2	99.4	106.8	86.3	94.8	103.0	81.5	89.4	98.0	76.3	83.7	92.0	71.3	77.7	85.9
		S/T	0.93	0.71	0.50	0.95	0.73	0.51	0.97	0.75	0.53	0.99	0.78	0.54	1.00	0.81	0.56
		KW	5.87	6.15	6.40	6.31	6.59	6.87	6.73	7.03	7.34	7.17	7.43	7.75	7.62	7.83	8.16
	2800 (0.11)	MBH	90.4	98.6	106.2	85.5	94.0	102.2	80.3	88.7	97.4	74.9	83.1	91.4	69.9	77.1	85.5
		S/T	0.91	0.69	0.50	0.93	0.71	0.51	0.97	0.73	0.52	0.99	0.76	0.53	1.00	0.79	0.54
		KW	5.84	6.10	6.36	6.28	6.56	6.84	6.68	6.99	7.31	7.12	7.40	7.69	7.55	7.80	8.13
	2250 (0.10)	MBH	86.5	95.2	103.2	81.9	90.6	98.6	76.9	85.5	94.2	71.1	80.1	88.7	66.3	74.1	83.1
		S/T	0.85	0.65	0.48	0.87	0.67	0.49	0.90	0.68	0.49	0.93	0.70	0.50	0.96	0.73	0.51
		KW	5.68	5.96	6.24	6.12	6.42	6.70	6.54	6.85	7.15	6.98	7.26	7.59	7.36	7.68	8.01

**FORMULAS AND NOTES FOR USING EXPANDED PERFORMANCE DATA**

To find leaving wet bulb and dry bulb from the expanded performance charts, use the following formulas.

- Direct interpolation is permissible. Do not extrapolate.
- The following formulas may be used:
  - $t/db = t\ edb - \text{sensible capacity Btuh} / (1.10 \times \text{cfm})$
  - $t/wb = \text{Wet bulb temp. corresponding to enthalpy of air leaving evaporator coil (h/wb)}$
  - $h/wb = h\ ewb - \text{total capacity Btuh} / (4.5 \times \text{cfm})$   
where h ewb = Enthalpy of air entering evap. coil
- The SHC is based on 80F edb of air entering evap coil. Below 80F edb, subtract (corr factor x cfm) from SHC. Above 80F edb, add (corr factor x cfm) to SHC.

**LEGEND**

---

MBH = Total Capacity (Gross)  
 S/T = Sensible to Total Ratio  
 KW = Compressor Motor Power Input.  
 IDB = Indoor Dry Bulb  
 edb = Entering Dry Bulb  
 ewb = Entering Wet Bulb  
 t/db = Leaving Dry Bulb  
 t/wb = Leaving Wet Bulb  
 h/wb = Enthalpy of Leaving Wet Bulb  
 SHC = Sensible Heat Capacity

BYPASS FACTOR (BF)	ENTERING AIR DRY BULB						Use formulas shown below
	79	78	77	76	75	under 75	
	81	82	83	84	85	over 85	
Correction Factor							
.05	1.04	2.07	3.11	4.14	5.18		
.10	0.98	1.96	2.94	3.92	4.90		
.20	0.87	1.74	2.62	3.49	4.36		
.30	0.76	1.53	2.29	3.05	3.82		

Correction Factor = 1.10 x (1-BF) x (edb-80).

**EXPANDED PERFORMANCE DATA (COOLING) 10 Ton (GROSS Capacity)**

Airflow CFM IDB (BF)			Outdoor Ambient Temperature - Degrees F, Dry Bulb														
			75			85			95			105			115		
			Entering Indoor Air Temperature - Degrees F, Wet Bulb														
			62	67	72	62	67	72	62	67	72	62	67	72	62	67	72
80	4500 (0.15)	MBH	120.6	131.2	143.1	115.6	125.3	136.7	109.5	119.3	129.9	102.3	112.4	123.2	97.2	105.8	120.2
		S/T	0.97	0.75	0.53	0.98	0.76	0.54	0.99	0.79	0.55	1.00	0.82	0.56	1.00	0.85	0.57
		KW	7.66	7.93	8.27	8.21	8.48	8.82	8.79	9.07	9.38	9.45	9.68	10.00	9.75	9.94	10.28
	4000 (0.125)	MBH	118.7	129.4	141.1	113.4	123.8	134.7	105.9	117.8	128.3	97.6	110.8	121.6	92.5	102.8	118.9
		S/T	0.94	0.72	0.51	0.96	0.73	0.52	0.99	0.76	0.53	1.00	0.78	0.55	1.00	0.82	0.55
		KW	7.60	7.88	8.20	8.15	8.43	8.75	8.71	9.01	9.33	9.35	9.62	9.94	9.66	9.88	10.23
	3500 (0.095)	MBH	114.8	126.5	137.8	108.2	121.2	131.8	100.9	115.2	125.6	92.3	107.2	119.3	88.0	100.0	116.4
		S/T	0.91	0.69	0.50	0.93	0.70	0.51	0.96	0.72	0.52	0.98	0.75	0.53	1.00	0.78	0.53
		KW	7.53	7.79	8.10	8.07	8.34	8.64	8.62	8.92	9.23	9.23	9.53	9.86	9.50	9.79	10.14

**FORMULAS AND NOTES FOR USING EXPANDED PERFORMANCE DATA**

To find leaving wet bulb and dry bulb from the expanded performance charts, use the following formulas.

- Direct interpolation is permissible. Do not extrapolate.
- The following formulas may be used:  
 $t/db = t\ edb - \text{sensible capacity Btuh} / (1.10 \times \text{cfm})$   
 $t/wb = \text{Wet bulb temp. corresponding to enthalpy of air leaving evaporator coil (h/wb)}$   
 $h/wb = h\ ewb - \text{total capacity Btuh} / (4.5 \times \text{cfm})$   
 where h ewb = Enthalpy of air entering evap. coil
- The SHC is based on 80F edb of air entering evap coil. Below 80F edb, subtract (corr factor x cfm) from SHC. Above 80F edb, add (corr factor x cfm) to SHC.

LEGEND	
MBH	= Total Capacity (Gross)
S/T	= Sensible to Total Ratio
KW	= Compressor Motor Power Input.
IDB	= Indoor Dry Bulb
edb	= Entering Dry Bulb
ewb	= Entering Wet Bulb
t/db	= Leaving Dry Bulb
t/wb	= Leaving Wet Bulb
h/wb	= Enthalpy of Leaving Wet Bulb
SHC	= Sensible Heat Capacity

BYPASS FACTOR (BF)	ENTERING AIR DRY BULB					
	79	78	77	76	75	under 75
	81	82	83	84	85	over 85
Correction Factor						
.05	1.04	2.07	3.11	4.14	5.18	Use formulas shown below
.10	0.98	1.96	2.94	3.92	4.90	
.20	0.87	1.74	2.62	3.49	4.36	
.30	0.76	1.53	2.29	3.05	3.82	

Correction Factor = 1.10 x (1-BF) x (edb-80).

**EXPANDED PERFORMANCE DATA (COOLING) 12-1/2 Ton (GROSS Capacity)**

Airflow CFM IDB (BF)			Outdoor Ambient Temperature - Degrees F, Dry Bulb														
			75			85			95			105			115		
			Entering Indoor Air Temperature - Degrees F, Wet Bulb														
			62	67	72	62	67	72	62	67	72	62	67	72	62	67	72
80	6250 (0.12)	MBH	151.0	162.0	173.9	147.1	156.8	169.5	142.3	150.9	164.0	136.7	143.7	156.4	128.1	133.2	148.4
		S/T	1.00	0.79	0.56	1.00	0.81	0.57	1.00	0.83	0.58	1.00	0.86	0.59	1.00	0.90	0.61
		KW	9.03	9.29	9.53	10.06	10.27	10.59	11.18	11.39	11.69	12.33	12.53	12.77	13.49	13.65	13.94
	5000 (0.10)	MBH	146.2	158.2	170.9	141.3	153.0	166.3	134.5	147.6	159.9	136.4	140.4	153.3	117.1	127.5	145.5
		S/T	0.96	0.73	0.52	0.97	0.75	0.53	0.99	0.76	0.54	0.93	0.79	0.55	1.00	0.83	0.56
		KW	8.93	9.19	9.46	9.96	10.17	10.51	11.03	11.30	11.57	12.14	12.43	12.72	13.30	13.52	13.84
	4500 (0.09)	MBH	142.6	155.3	167.3	137.4	150.2	162.6	129.3	144.6	157.2	119.1	137.2	150.7	109.1	11.9	142.1
		S/T	0.92	0.70	0.51	0.93	0.71	0.51	0.96	0.72	0.52	0.99	0.74	0.53	1.00	8.14	0.54
		KW	8.87	9.12	9.36	9.87	10.12	10.39	10.93	11.22	11.51	12.02	12.33	12.64	13.15	13.44	13.73
	3750 (0.08)	MBH	139.9	152.0	164.6	133.6	147.1	159.9	124.4	141.5	154.2	114.0	134.2	147.8	102.8	120.4	139.7
		S/T	0.87	0.67	0.49	0.89	0.68	0.50	0.92	0.69	0.51	0.96	0.71	0.51	1.00	0.75	0.52
		KW	8.82	9.04	9.30	9.82	10.03	10.33	10.84	11.13	11.43	11.91	12.23	12.57	13.02	13.35	13.64

**FORMULAS AND NOTES FOR USING EXPANDED PERFORMANCE DATA**

To find leaving wet bulb and dry bulb from the expanded performance charts, use the following formulas.

1. Direct interpolation is permissible. Do not extrapolate.

2. The following formulas may be used:

$$t/db = t\ edb - \text{sensible capacity Btuh} / (1.10 \times \text{cfm})$$

$$t/wb = \text{Wet bulb temp. corresponding to enthalpy of air leaving evaporator coil (h/wb)}$$

$$h/wb = h\ ewb - \text{total capacity Btuh} / (4.5 \times \text{cfm})$$

where h ewb = Enthalpy of air entering evap. coil

3. The SHC is based on 80F edb of air entering evap coil.  
Below 80F edb, subtract (corr factor x cfm) from SHC.  
Above 80F edb, add (corr factor x cfm) to SHC.

LEGEND	
MBH	= Total Capacity (Gross)
S/T	= Sensible to Total Ratio
KW	= Compressor Motor Power Input.
IDB	= Indoor Dry Bulb
edb	= Entering Dry Bulb
ewb	= Entering Wet Bulb
t/db	= Leaving Dry Bulb
t/wb	= Leaving Wet Bulb
h/wb	= Enthalpy of Leaving Wet Bulb
SHC	= Sensible Heat Capacity

BYPASS FACTOR (BF)	ENTERING AIR DRY BULB					
	79	78	77	76	75	under 75
	81	82	83	84	85	over 85
Correction Factor						
.05	1.04	2.07	3.11	4.14	5.18	Use formulas shown below
.10	0.98	1.96	2.94	3.92	4.90	
.20	0.87	1.74	2.62	3.49	4.36	
.30	0.76	1.53	2.29	3.05	3.82	

$$\text{Correction Factor} = 1.10 \times (1 - \text{BF}) \times (\text{edb} - 80).$$



**PERFORMANCE DATA**

**CIRCULATING BLOWER PERFORMANCE - 7-1/2 TON UNITS (2.4 BHP Standard Motor w/590-840 rpm Drive Pkg)**

CFM	EXTERNAL STATIC PRESSURE IN INCHES WATER COLUMN - DRY COIL WITH FILTER															
	0.3		0.5		0.7		0.9		1.1		1.3		1.5		1.7	
	RPM	W	RPM	W	RPM	W	RPM	W	RPM	W	RPM	W	RPM	W	RPM	W
2500	<b>551</b>	<b>669</b>	626	859	693	1056	753	1275	808	1499	859	1735	912	2050	963	2470
2750	590	807	663	1019	726	1237	783	1474	837	1722	886	1971	933	2228	980	2529
3000	630	973	699	1207	759	1447	815	1700	866	1971	915	2240	961	2504	1003	2767
3250	671	1174	737	1426	794	1701	<b>848</b>	<b>1967</b>	898	2244	944	2529	989	2807	1034	3085
3500	712	1413	774	1683	830	1971	881	2257	930	2546	976	2831				

- NOTES: 1) Maximum motor Watts is 2120 for standard 2.4 HP motor.  
 2) Maximum blower wheel speed is 1026 rpm.  
 3) Motor drive range is 590 to 840 rpm.  
 4) Air flow data based on dry coil with filters. Deduct 0.08 inches for wet coil performance.  
 5) Operation in shaded areas requires accessory high static motor and drive kit sold separately.  
 6) Boldface indicates field-supplied drive is required.

**CIRCULATING BLOWER PERFORMANCE - 10 TON UNITS (2.4 BHP Standard Motor w/685-935 rpm Drive Pkg)**

CFM	EXTERNAL STATIC PRESSURE IN INCHES WATER COLUMN - DRY COIL WITH FILTER															
	0.3		0.5		0.7		0.9		1.1		1.3		1.5		1.7	
	RPM	W	RPM	W	RPM	W	RPM	W	RPM	W	RPM	W	RPM	W	RPM	W
3500	<b>669</b>	<b>1039</b>	733	1207	786	1361	838	1526	888	1691	933	1858	<b>976</b>	<b>2074</b>	1020	2238
3750	708	1233	767	1413	821	1600	869	1753	918	1945	963	2174	1004	2349	1044	2528
4000	747	1456	801	1639	857	1858	902	2032	948	2265	993	2469	1034	2670	1072	2866
4250	786	1718	839	1928	893	2170	936	2393	979	2574	1022	2801	1066	3028		
4500	826	2006	876	2273	927	2505	973	2744	1012	2952						

- NOTES: 1) Maximum motor Watts is 2120 for standard 2.4 HP motor.  
 2) Maximum blower wheel speed is 1026 rpm.  
 3) Motor drive range is 685-935 rpm.  
 4) Air flow data based on dry coil with filters. Deduct 0.08 inches for wet coil performance.  
 5) Operation in shaded areas requires accessory high static motor and drive kit sold separately.  
 6) Boldface indicates field-supplied drive is required.

**CIRCULATING BLOWER PERFORMANCE - 12-1/2 TONS (5.25 BHP Standard Motor w/900-1260 rpm Drive Pkg)**

CFM	EXTERNAL STATIC PRESSURE IN INCHES WATER COLUMN - DRY COIL WITH FILTER															
	0.3		0.5		0.7		0.9		1.1		1.3		1.5		1.7	
	RPM	W	RPM	W	RPM	W	RPM	W	RPM	W	RPM	W	RPM	W	RPM	W
4000					889	2990	941	3213	991	3453	1040	3783	1089	4076	1137	4334
4500			914	2884	962	3151	1010	3382	1056	3613	1101	3925	1144	4245	1188	4530
5000	942	2768	993	3035	1039	3320	1080	3551	1125	3783	1166	4085	1207	4423		
5500	1027	2928	1073	3204	1118	3489	1157	3729								
6000	1111	3088														

- NOTES: 1) Maximum motor Watts is 4,673 for standard 5.25 HP motor.  
 2) Maximum blower wheel speed is 1280 rpm.  
 3) Motor drive range is 900 to 1260 rpm.  
 4) Air flow data based on dry coil with filters. Deduct 0.08 inches for wet coil performance.  
 5) Operation in shaded areas requires accessory high static drive kit sold separately.  
 6) Boldface indicates field-supplied drive is required.

**PERFORMANCE DATA (cont)  
AIR QUANTITY LIMITS**

UNIT PGE	MINIMUM CFM	MAXIMUM CFM
090	2250	3750
120	3000	5000
150	3750	6250

**SOUND POWER (TOTAL UNIT)**

UNIT PGE	SOUND RATING 60 Hz	A-WEIGHTED (dB)	OCTAVE BANDS							
			63	125	250	500	1000	2000	4000	8000
090	87 dB	86.4	83.2	87.4	83.5	82.8	83.0	77.7	71.8	67.0
120	88 dB	87.6	97.6	90.4	85.7	84.8	83.9	77.5	71.3	65.8
150	86 dB	86.0	63.7	69.9	72.5	78.2	81.1	77.3	73.3	66.8

**FAN RPM AT MOTOR PULLEY SETTINGS\***

UNIT PGE	MOTOR PULLEY TURNS OPEN												
	0	1/2	1	1 1/2	2	2 1/2	3	3 1/2	4	4 1/2	5	5 1/2	6
090 <sup>1</sup>	840	815	790	765	740	715	690	655	635	615	590	-	-
090 <sup>2</sup>	1080	1025	1007	988	970	952	933	915	897	878	860	-	-
120 <sup>1</sup>	935	910	885	860	835	810	785	760	735	710	685	-	-
120 <sup>2</sup>	1130	1112	1087	1062	1037	1012	987	962	937	912	887	862	830
150 <sup>1</sup>	1260	1220	1185	1155	1130	1100	1075	1045	1015	990	960	930	900

\* Approximate fan rpm shown.

1 - Indicates standard motor and drive package.

2 - Indicates optional high static motor and drive package.

**PERFORMANCE DATA (CONT.)**

<b>Evaporator-Fan Motor Efficiency</b>		<b>Altitude Derating Factor*</b>	
PGE	Motor Efficiency (%)	Elevation (ft.)	Maximum Heating Value (Btu/ft <sup>3</sup> )
090-120	80	0 -2000	1100
150	87	2001 - 3000	1050
		3001 - 4000	1000
		4001 - 5000	950
		5001 - 6000	900

\* Derating of the unit is not required unless the heating value of the gas exceeds the values listed in the table above, or if the elevation exceeds 6000 ft. Derating conditions must be 4% per thousand ft. above sea level. For example at 4000 ft. If the heating value of the gas exceeds 1000 Btu/ft<sup>3</sup>, the unit will require a 16% derating. For elevations above 6000 ft., the same formula applies. For example, at 7000 ft., the unit will require a 28% derating of the maximum heating value per the National Fuel Gas Code.

**EVAPORATOR-FAN MOTOR PERFORMANCE**

Unit PGE	Evaporator-Fan Motor	Unit Voltage	Max. Acceptable Continuous BHP*	Max. Acceptable Operating Watts	Max. AMP Draw
090	Standard	208/230	2.40	2120	6.7
		460			3.0
		575			3.0
	Optional High Static	208/230	3.70	3313	12.2
		460			5.5
		575			5.5
120	Standard	208/230	2.40	2120	6.7
		460			3.0
		575			3.0
	Optional High Static	208/230	5.25	4400	17.3
		460			8.5
		575			8.5
150	Standard	208/230	5.25	4400	17.3
		460			8.5
		575			8.5

**LEGEND**

BHP = Brake Horsepower

\* Extensive motor and electrical testing on these units ensures that the full horsepower range of the motors can be utilized with confidence. Using your fan motors up to the horsepower ratings shown in this table will not result in nuisance tripping or premature motor failure. Unit Warranty will not be affected.

All indoor-fan motors 5 hp and larger meet the minimum efficiency requirements as established by the Energy Policy Act of 1992 (EPACT) effective October 24, 1997.

**TYPICAL INSTALLATIONS**

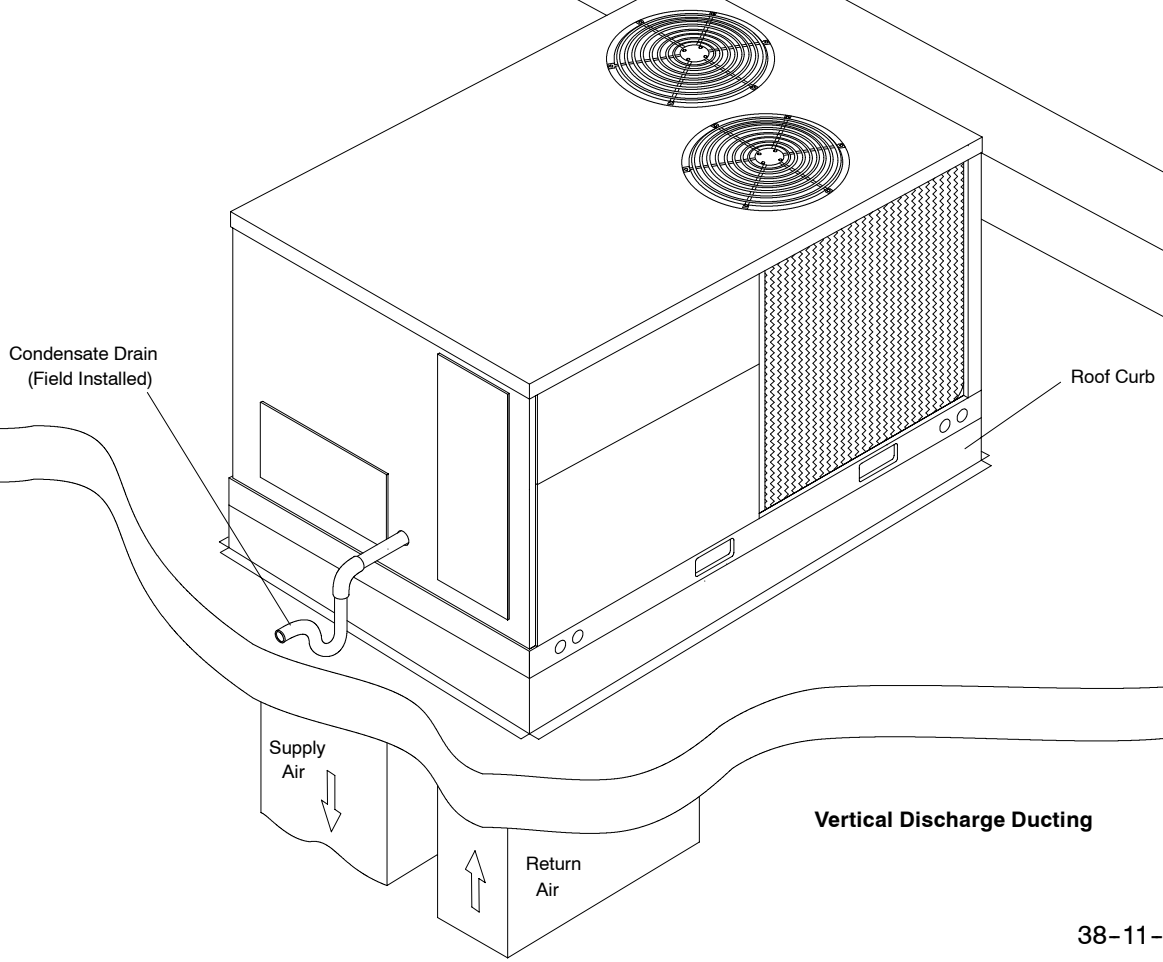
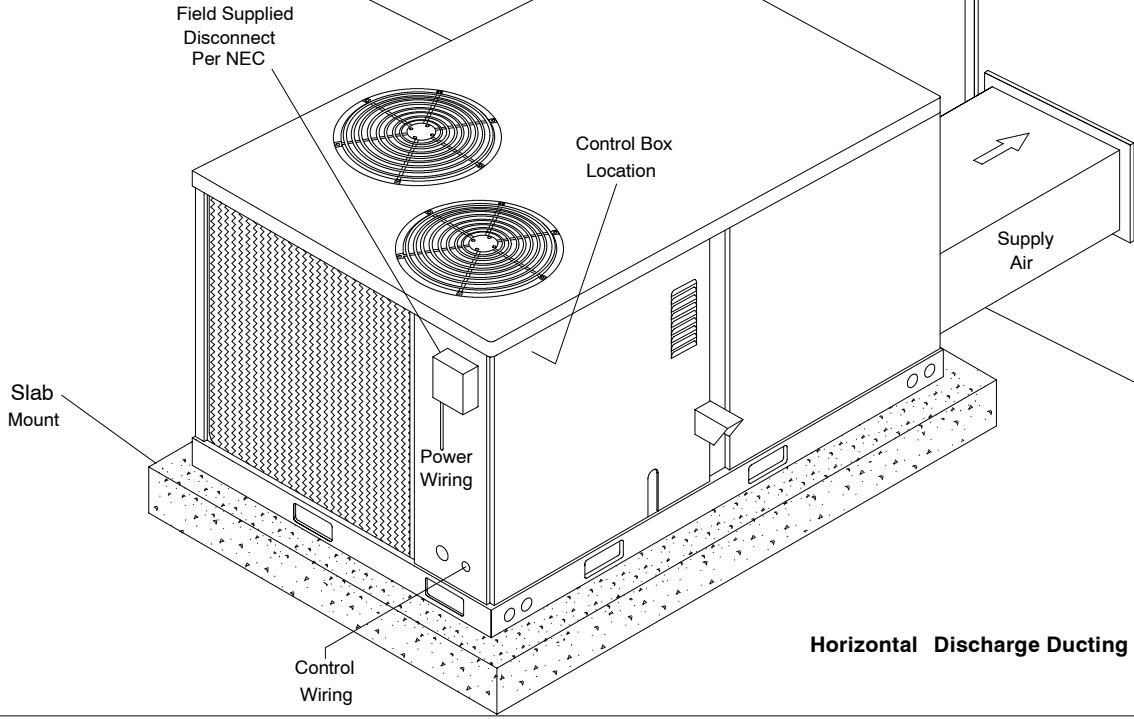

38-11-37

# ACCESSORIES

## ROOF CURBS

Description	Model Number	Where Used
8" High *	AXB045CLA	090, 120, 150
14" High *	AXB045CMA	090, 120, 150
24" High *	AXB045CHA	090, 120, 150

\* A Dimension

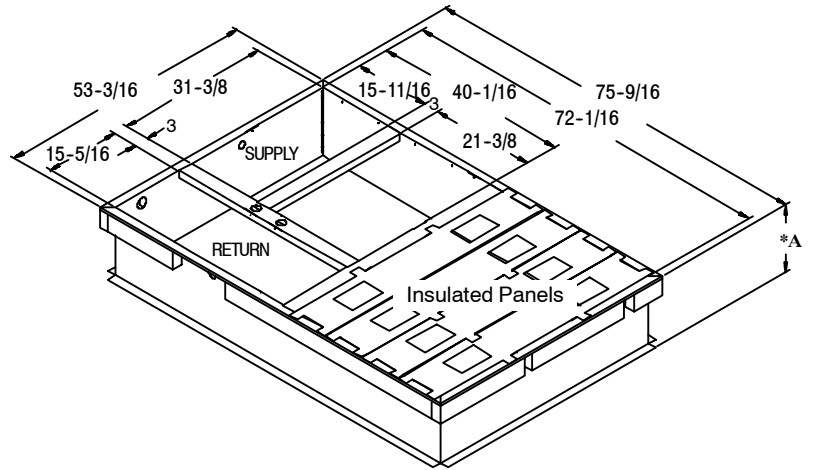

## ECONOMIZER - DOWNFLOW

Description	Model Number	A Dimension	B Dimension	Where Used
Fully Modulating	AXB145EMA	13-3/4"	12-3/4"	90
	AXB245EMA	16-1/2"	17-3/4"	120, 150
Three Position	AXB145EPA	13-3/4"	12-3/4"	90
	AXB245EPA	16-1/2"	17-3/4"	120, 150

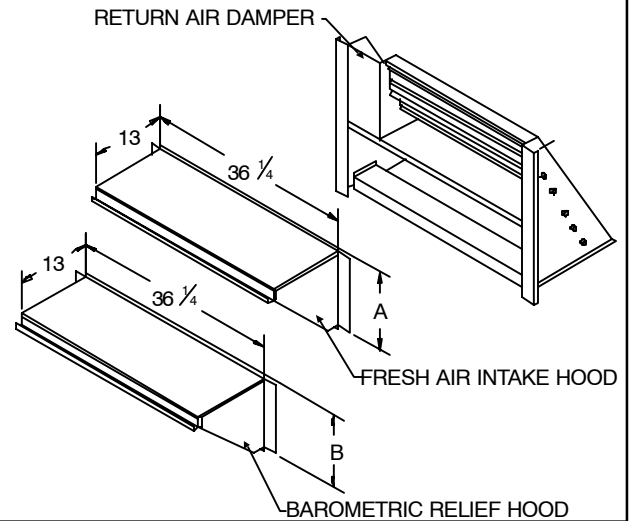

## ECONOMIZER - HORIZONTAL

Description	Model Number	Where Used
Fully Modulating	AXB145HEA	90
	AXB245HEA	120, 150
Three Position	AXB145HPA	90
	AXB245HPA	120, 150

**ECONOMIZER ADAPTOR**  
The height of the economizer adapter opening is the only difference between the AXB145 & AXB245.  
(SHIPPED ATTACHED TO THE ECONOMIZER)

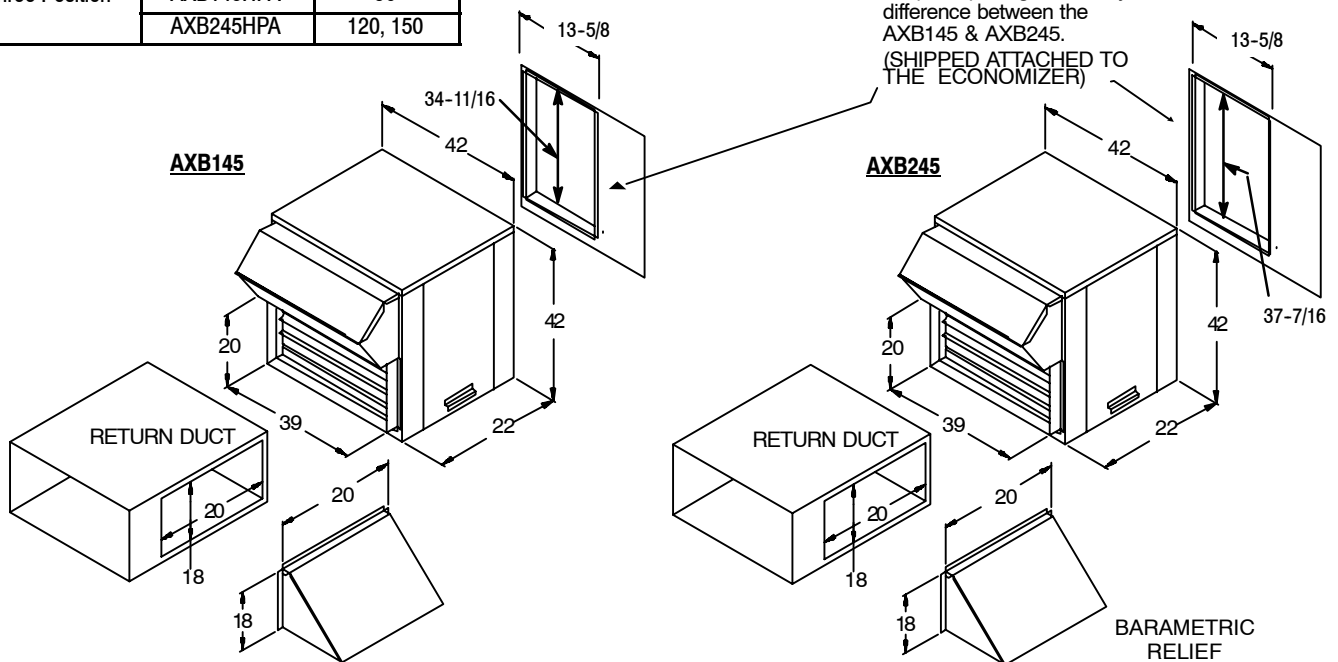

## ACCESSORIES (CONT.)

### FRESH AIR DAMPER

Description	Model Number	A Dimension	Where Used
Manual	AXB145FAA	27-15/16	90
	AXB245FAA	32-1/2	120, 150
Motorized	AXB145FMA	27-15/16	90
	AXB245FMA	32-1/2	120, 150

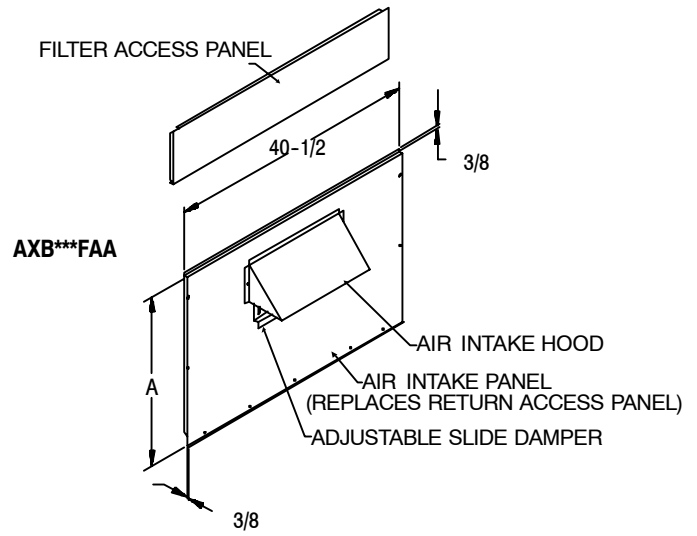
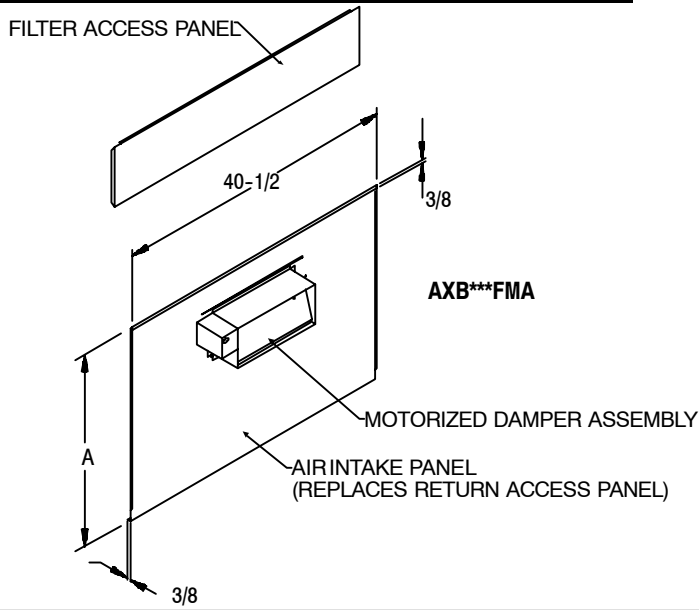

### COIL PROTECTION

### DIMENSIONS

Description	Model Number	Where Used	A	B
Coil Guard	AXB145CGA	90	44	37
	AXB245CGA	120, 150	45-3/8	45
Hail Guard	AXB145HGA	90	42	36
	AXB245HGA	120, 150	43-3/8	44

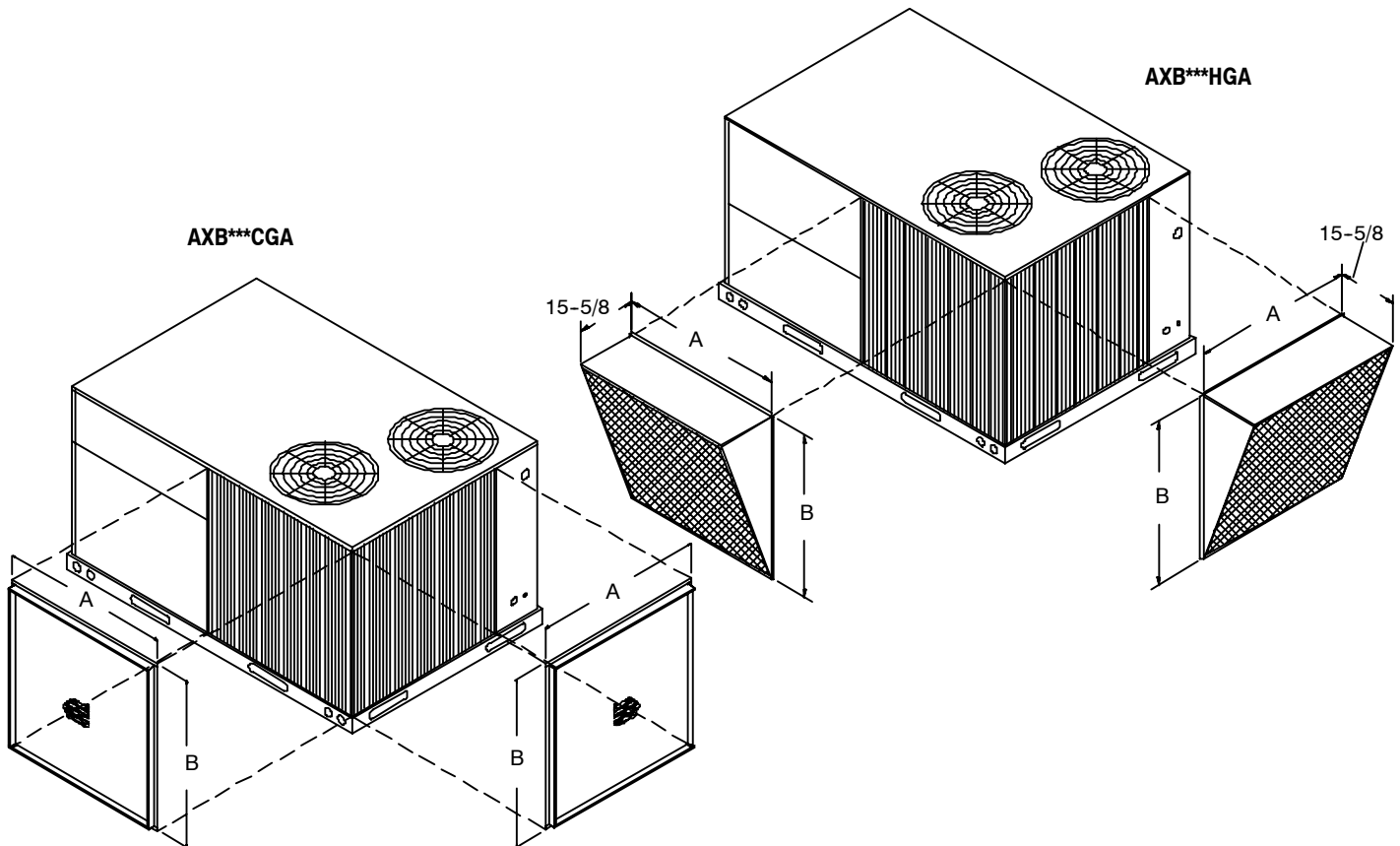

## ACCESSORIES (CONT.)

### CONCENTRIC DUCT KIT

Description	Model Number	Where Used
20" Round	AXB445CTA	090
18" x 28" Rect.	AXB545CTA	120
18" x 32" Rect.	AXB645CTA	150

AXB445CTA  
SHOWN

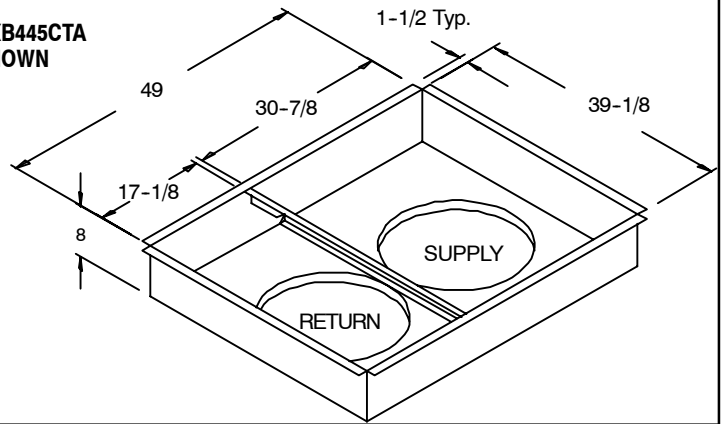

### PERFORMANCE DATA ON NEXT PAGE

### CONCENTRIC DIFFUSER

Description	Model Number	Used With
Flush Mount	AXB040CFA	AXB445CTA
Flush Mount	AXB045CFA	AXB545CTA
Flush Mount	AXB050CFA	AXB645CTA
Step Down	AXB040CSA	AXB445CTA
Step Down	AXB045CSA	AXB545CTA
Step Down	AXB050CSA	AXB645CTA

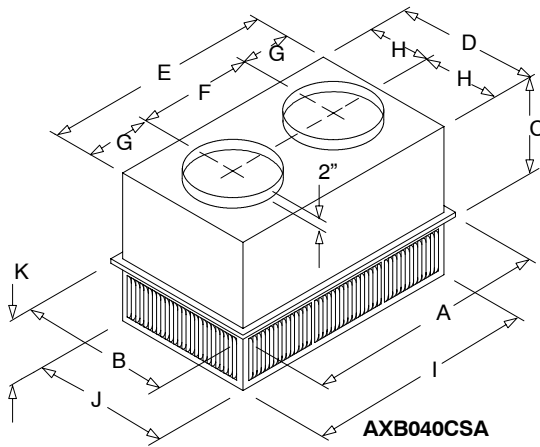

ANTI-SWEAT  
GASKET

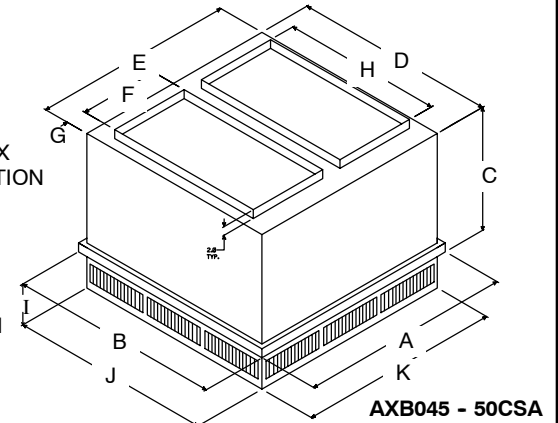
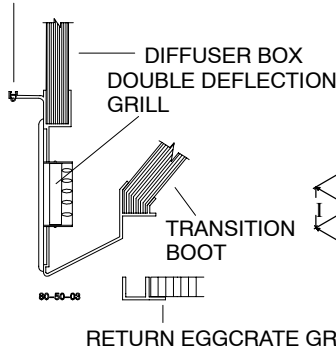

AXB045 - 50CSA

### CONCENTRIC DIFFUSER (Step Down)

Model Number	A	B	C	D	E	F	G	H	I	J	K	Duct Size
AXB040CSA	47-5/8	23-5/8	14-3/8	27-1/2	45-1/2	22-1/2	11-1/2	13-3/4	45-1/2	27-1/2	8-1/8	20" RD
AXB045CSA	47-5/8	35-5/8	20-5/8	33-1/2	45-1/2	18	2-1/2	28	9-1/8	33-1/2	45-1/2	18 x 28
AXB050CSA	47-5/8	41-5/8	25-7/8	45-1/2	45-1/2	18	2-1/2	32	9-1/8	39-1/2	45-1/2	18 x 32

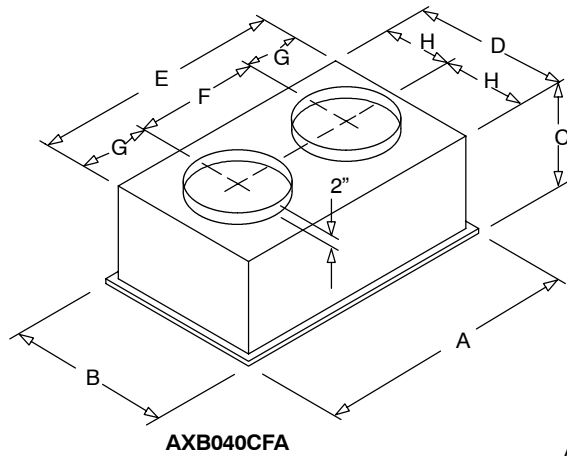

AXB040CFA

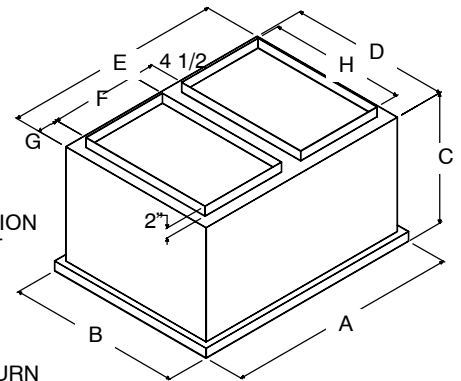
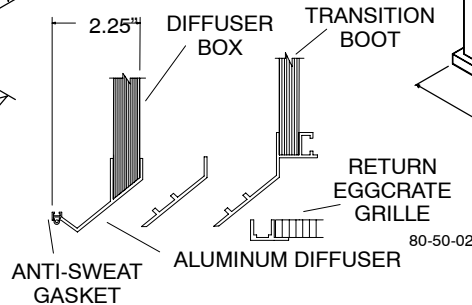

AXB045 - 50CFA

### CONCENTRIC DIFFUSER (Flush Mount)

Model Number	A	B	C	D	E	F	G	H	Duct Size
AXB040CFA	47-5/8	29-5/8	16-5/8	27	45	22-1/2	11-1/4	13-1/2	20" RD
AXB045CFA	47-5/8	35-5/8	21-3/4	33	45	18	2-1/4	28	18 x 28
AXB050CFA	47-5/8	41-5/8	29-1/4	39	45	18	2-1/4	32	18 x 32

## ACCESSORIES (CONT.)

### CSA SERIES STEP-DOWN PERFORMANCE

Part No. AXB	CFM	Static Pressure In. WC	Throw Feet	Neck / Jet Velocity FPM	db Sound Levels
040CSA	2600	.17	24-29	669	20
	2800	.20	25-30	720	25
	3000	.25	27-33	772	25
	3200	.31	28-35	823	25
	3400	.37	30-37	874	30
045CSA	3600	.17	25-33	851	30
	3800	.18	27-35	898	30
	4000	.21	29-37	946	30
	4200	.24	32-40	993	30
	4400	.27	34-42	1040	30
050CSA	4400	.29	25-30	733	30
	4600	.31	26-31	767	30
	4800	.32	27-32	800	30
	5000	.34	28-33	833	30
	5200	.36	28-34	867	30
	5400	.39	29-35	900	30

### CFA SERIES FLUSH MOUNT PERFORMANCE

Part No. AXB	CFM	Static Pressure In. WC	Throw Feet	Neck Velocity FPM	Jet Velocity FPM	db Sound Level
040CFA	2600	.17	19-24	663	1294	30
	2800	.20	20-28	714	1393	35
	3000	.25	21-29	765	1492	35
	3200	.31	22-29	816	1592	40
	3400	.37	22-30	867	1692	40
	045CFA	3600	.17	22-29	844	1646
3800		.18	22-30	891	1737	40
4000		.21	24-33	938	1829	40
4200		.24	26-35	985	1920	40
4400		.27	28-37	1032	2011	40
050CFA		4600	.31	25-34	922	1795
	4800	.32	26-35	962	1873	40
	5000	.34	27-36	1002	1951	40
	5200	.36	30-39	1043	2029	45
	5400	.39	32-41	1083	2107	45

#### CSA/CFA NOTES:

1. All data is based on the Air Diffusion Council guidelines.
2. Throw data is based on Terminal Velocities of 75 FPM using isothermal air.
3. Throw is based on diffuser blades being directed in a straight pattern.
4. Actual sound levels are less than those shown.
5. Minimum height 9' above floor.

### NATURAL TO LP CONVERSION KIT

Model Number	Used With
AXB345LPA	090, 150
<b>LOW AMBIENT KIT</b>	
Model Number	Used With
AXB045LAA	090, 150
<b>THRU-THE-BASE POWER KIT</b>	
Model Number	Used With
AXB045PKA	090, 150
With 1-1/4" Power and 3/4" Gas Connections.	

### PART NUMBERS FOR APPROVED HIGH STATIC CONVERSIONS\*

Unit Size	Voltage	Motor	Motor Pulley	Blower Pulley	Belt	Circuit Breaker	Circuit Breaker Bracket
7-1/2 Ton	All Voltages	1171340	1171423	1171415	1171514	N/A	N/A
10 Ton	208/230	1171312	1171424	1171417	1171512	1171080	1171063
10 Ton	460 & 575	1171312	1171424	1171417	1171512	1171079	1171063
12-1/2 Ton	All Voltages	N/A	N/A	N/A	N/A	N/A	N/A

\* Available thru service parts only.



## ACCESSORIES (CONT.)

### POWER EXHAUST

Description	Model Number	Where Used
208/230 Volt	AXB145PEH	090
460 Volt	AXB145PEL	090
575 Volt	AXB145PES	090
208/230 Volt	AXB245PEH	120, 150
460 Volt	AXB245PEL	120, 150
575 Volt	AXB245PES	120, 150

### POWER EXHAUST PERFORMANCE DATA

Model	Volt/Phase/ Hertz	Motor				Unit									
		Qty	HP	RPM	Cir. Qty	LRA	FLA	MCA	Fuse Size	@0.0		@0.1	@0.3		
										CFM	RPM	CFM	CFM	RPM	
AXB145PEH	208-230/1/60	1	1/2	1725	1	10.2	4.3	5.4	8	2400	1725	N/A	2100	1725	
AXB145PEL	460/1/60	1	1/2	1625	1	4.1	1.7	2.2	5	2300	1625	N/A	2000	1625	
AXB145PES	575/1/60	1	1/2	1625	1	4.1	1.7	2.2	5	2300	1625	N/A	2000	1625	
AXB245PEH	208-230/1/60	1	3/4	1075	1	24.9	5.0	6.3	10	N/A	N/A	4800	N/A	N/A	
AXB245PEL	460/1/60	1	3/4	1075	1	N/A	2.2	2.8	5	N/A	N/A	4800	N/A	N/A	
AXB245PES	575/1/60	1	3/4	1050	1	N/A	1.5	1.9	4	N/A	N/A	4800	N/A	N/A	

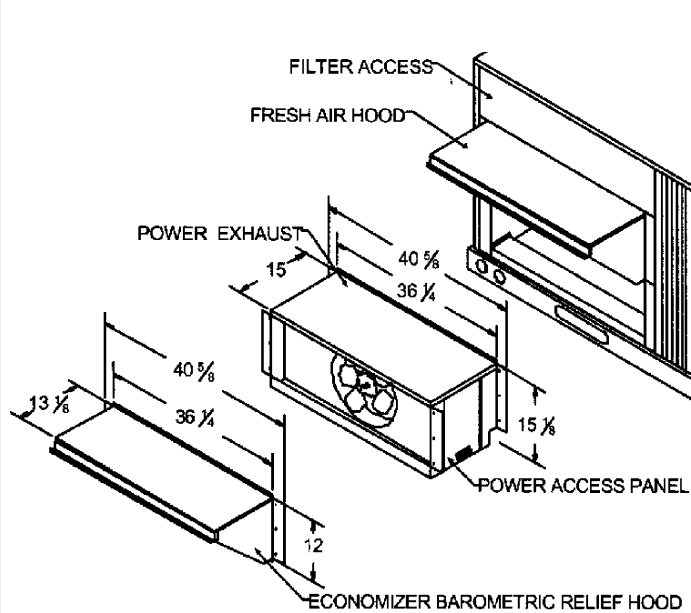

POWER EXHAUST DOWNFLOW, MODEL AXB145\*\*\*

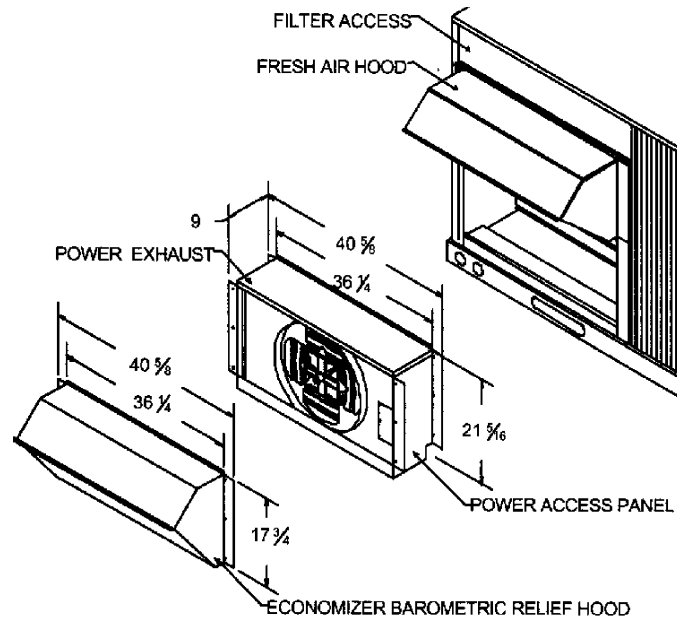

POWER EXHAUST DOWNFLOW, MODEL AXB245\*\*\*

## CONTROLS

### OPERATING SEQUENCE

**Cooling, Units Without Economizer** When thermostat calls for cooling, terminals G and Y1 are energized. The indoor (evaporator) fan contactor (IFC), compressor contactor no. 1 (C1) and outdoor-fan contactor (OFC) are energized, and evaporator-fan motor, compressor no. 1, and both condenser fans start. The condenser-fan motors run continuously while unit is cooling. If the thermostat calls for a second stage of cooling by energizing Y2, compressor contactor no. 2 (C2) is energized and compressor no. 2 starts.

When the thermostat is satisfied, C1 and C2 are deenergized and the compressors and outdoor (condenser) fan motors (OFM) shut off. After a 30-second delay, the indoor (evaporator) fan motor (IFM) shuts off. If the thermostat fan selector switch is in the ON position, the evaporator-fan motor will run continuously.

**Heating, Units Without Economizer** When the thermostat calls for heating, terminal W1 is energized. In order to prevent thermostat short-cycling, the unit is locked into the Heating mode for at least 1 minute when W1 is energized. The induced-draft motor (IDM) is then energized and the burner ignition sequence begins. The indoor (evaporator) fan motor (IFM) is energized 45 seconds after a flame is ignited. On units equipped for two stages of heat, when additional heat is needed, W2 is energized and the high-fire solenoid on the main gas valve (MGV) is energized. When the thermostat is satisfied and W1 and W2 are deenergized, the IFM stops after a 45-second time-off delay.

## APPLICATION DATA

- 1. DUCTWORK** Secure vertical discharge ductwork to roof curb. For horizontal discharge applications, attach ductwork to unit, or field-supplied flanges can be attached to horizontal discharge openings and all ductwork attached to flanges.
- 2. THRU-THE-BOTTOM UTILITY CONNECTIONS** An accessory kit is required for proper installation of thru-the-bottom connections.
- 3. THERMOSTAT** Use of 2-stage cooling thermostat is recommended for all units.
- 4. HEATING-TO-COOLING CHANGEOVER** All units are automatic changeover from heating to cooling when automatic changeover thermostat and subbase are used.
- 5. AIRFLOW** Units are draw-thru on cooling and blow-thru on heating.
- 6. MAXIMUM AIRFLOW** To minimize the possibility of condensate blow-off from evaporator, airflow through units should not exceed 500 cfm/ton.
- 7. MINIMUM AIRFLOW** The minimum airflow for cooling is 300 cfm/ton.
- 8. MINIMUM AMBIENT COOLING OPERATION TEMPERATURE** The cooling temperature for size all units is 25 F.
- 9. MAXIMUM OPERATING OUTDOOR-AIR TEMPERATURE** For cooling, this temperature is 115 F.
- 10. HIGH ALTITUDE** A change to the gas orifice may be required at high altitudes. Refer to Altitude Compensation charts.
- 11. MINIMUM TEMPERATURE** Air entering the heat exchanger in heating must be a minimum of 50 F continuous and 45 F intermittent.
- 12. INTERNAL UNIT DESIGN** Due to the PGS internal unit design (draw-thru over the motor), air path, and specially designed motors, the full horsepower (maximum continuous bhp) listed in the Physical Data table and the notes following each Fan Performance table can be utilized with extreme confidence. Using PGS motors with the values listed in the Physical and Fan Performance Data tables will not result in nuisance tripping or premature motor failure. The unit warranty will not be affected.

## GUIDE SPECIFICATIONS: PGE090-150

### **CABINET:**

The cabinet shall be made of sturdy baked enamel coated galvanized steel. Base rails shall be 16 gauge steel and have fork lift slots and holes provided for lifting shackles. Unit shall be designed with convertible airflow and shipped ready for downflow applications with conversion to horizontal air flow accomplished by relocating two panels.

Return air compartments shall be insulated with not less than 1/2" of water resistant coated glass fiber and not less than 1/2" of aluminum foil faced glass fiber in the furnace/supply compartments.

### **COOLING SECTION:**

Units shall be factory charged and operationally ready. Each refrigeration circuit shall have a compressor, with internal overload protection, high and low pressure switches, filter drier and copper tube/aluminum fin evaporator and condenser coils.

Units shall be capable of cooling operation down to 25°F as shipped from the factory.

### **COILS:**

The evaporator and condenser coils shall be fabricated with aluminum fins mechanically bonded to copper tubing. Both coils shall be pressure tested prior to assembly into the unit and electronically leak tested after assembly onto the unit. The evaporator coil shall be protected from dust and debris on the return air side by factory installed 2" air filters.

### **CONDENSER FAN:**

The unit shall have a single direct drive propeller fan/motor assembly mounted directly to a vertical-discharge grille panel that is easily removable. Motors shall have permanently lubricated sleeve bearings and inherent overload protection.

### **EVAPORATOR BLOWER:**

The units shall have a single belt driven evaporator blower. The motor shall have permanently lubricated ball bearings and internal overload protection. An adjustable motor drive sheave for matching air flow requirements shall be standard. Additionally high static accessory kits shall be available for air flows above the standard requirement.

### **HEATING SECTION:**

The units shall have aluminized steel tubular heat exchangers located on the discharge side of the evaporator blower and equipped with a two-stage gas valve. The units shall have in-shot burners that are ignited by an electronic spark with flame proving feature and protected by both a limit switch and flame roll-out switch.