



PAN5

Product Specifications

15 SEER, PACKAGE AIR CONDITIONING UNITS, 2 – 5 TONS

Single Phase, 208/230 V, 60 Hz

REFRIGERATION CIRCUIT

- Environmentally sound R-410A refrigerant
- Copper tube/aluminum fin condenser and evaporator coils
- Two stage scroll compressors standard on all models

EASY TO INSTALL AND SERVICE

- Installs easily on a rooftop or at ground level
- Easy single-panel accessibility for maintenance and installation
- Easily converts to down discharge applications

BUILT TO LAST

- Wire grille
- Pre-painted steel cabinet
- High efficiency X-13 indoor blower motor on all models
- Vertical condenser fan discharge
- Rust-proof base with integral sloping drain
- High and low pressure switches provide added reliability for the compressor

WARRANTY*

- 5 year compressor limited warranty
- 5 year parts limited warranty (including compressor and coils)
 - With timely registration, an additional 5 year parts limited warranty (including compressor and coils)

*Applies to original purchaser/homeowner, some limitations may apply. See warranty certificate for complete details.



As an Energy Star® Partner, International Comfort Products has determined that this product meets the ENERGY STAR® guidelines for energy efficiency.



UNIT PERFORMANCE DATA						
Model Number	COOLING				Unit Dimensions Height x Width x Depth Inches (mm)	Operating Weight lbs / kg
	Net Capacity BTU/h High / Low Stage	Standard CFM High / Low Stage	S.E.E.R	E.E.R.		
PAN524000K00A	22,600 / 17,600	800 / 600	15.5	11.4	41x48x33 (1041x1226x831)	363 (165)
PAN536000K00A	34,600 / 24,400	1200 / 800	15.0	12.0	45x48x44 (1093x1226x1123)	447 (203)
PAN548000K00A	46,000 / 33,400	1600 / 1100	15.0	11.0	47x48x44 (1193x1226x1123)	475 (215)
PAN560000K00A	57,000 / 40,500	1750 / 1200	14.5	11.0	51x48x44 (1295x1226x1123)	526 (239)

UNIT SPECIFICATIONS				
UNIT SIZE	PAN524	PAN536	PAN548	PAN560
NOMINAL COOLING CAPACITY (ton)	2	3	4	5
OPERATING WEIGHT (lb/kg)	363 / 165	447 / 203	475 / 215	526 / 239
COMPRESSOR	Two-Stage Scroll			
REFRIGERANT (R-410A) QUANTITY (lb/kg)	10.1/4.6	9.5/4.3	15.3/6.9	15.8/7.2
REFRIGERANT METERING DEVICE	TXV			
Size	2 Ton	3 Ton	4 Ton	5 Ton
Part Number	EA36YD129	EA36YD139	EA36YD149	EA36YD159
OUTDOOR FAN				
Nominal CFM	2700	2800	3300	3300
Diameter (in./mm)	22/559	22/559	22/559	22/559
Motor HP (RPM)	1/8 (825)	1/8 (825)	1/4 (1100)	1/3 (1110)
OUTDOOR COIL				
Rows...Fins/in	2...21	2...21	2...21	2...21
Face Area (sq. ft.)	13.6	17.5	19.4	23.3
INDOOR COIL				
Rows...Fins/in	3...17	3...17	3...17	4...17
Face Area (sq. ft.)	3.7	4.7	5.7	5.7
INDOOR BLOWER				
Nominal Low Stage Airflow (CFM)	600	800	1100	1200
Nominal High Stage Airflow (CFM)	800	1200	1600	1750
Blower Wheel Size (in. x in.)	10x10	11x10	11x10	11x10
Blower Wheel Size (mm x mm)	254x254	279x254	279x254	279x254
Motor HP (RPM)	1/2	3/4	1	1
HIGH-PRESSURE SWITCH (psig)				
Cutout	670+/-10			
Reset (Auto)	470+/-25			
HIGH-PRESSURE SWITCH 2 (psig) (Compressor Solenoid)				
Cutout	565+/-15			
Reset (Auto)	455+/-15			
LOSS-OF-CHARGE/LOW-PRESSURE SWITCH (Liquid Line) (psig)				
Cutout	23+/-5			
Reset (Auto)	55+/-5			
RETURN-AIR FILTERS (in.) Throwaway*	20x20x1	24x30x1	24x36x1	24x36x1
RETURN-AIR FILTERS (mm) Throwaway*	508x508x25	610x762x25	610x914x25	610x914x25

* Recommended filter sizes for field-installed air filter grilles mounted on the wall or ceiling of the conditioned structure. Required filter sizes shown are based on the ARI (Air Conditioning and Refrigeration Institute) rated high stage cooling airflow and a maximum face velocity of 300 ft/minute for throwaway filters or 450 ft/minute for permanent filters. Air filter pressure drop for non-standard filters must not exceed .08 inches water column.

Dry Coil Air Delivery* – Horizontal and Downflow Discharge – Unit PAN524–60

Unit (Voltage)	Motor Speed	Wire Color		External Static Pressure (IN. W.C.)									
				0.1	0.2	0.3	0.4	0.5	0.6	0.7	0.8	0.9	
PAN524 (208/230-1-60)	Low ¹	Blue	CFM	659	551	440	335	---	---	---	---	---	---
	Med-Low	Pink	CFM	726	625	537	407	---	---	---	---	---	---
	Medium ²	Red	CFM	907	837	759	679	588	474	343	---	---	---
	Med-High	Orange	CFM	953	870	807	718	652	528	443	---	---	---
	High	Black	CFM	1179	1118	1061	996	942	864	794	718	619	---
PAN536 (208/230-1-60)	Low ¹	Blue	CFM	921	740	448	---	---	---	---	---	---	---
	Med-Low	Pink	CFM	1019	849	603	479	---	---	---	---	---	---
	Medium	Red	CFM	1272	1203	1150	1097	1054	996	937	881	841	---
	Med-High ²	Orange	CFM	1321	1258	1212	1168	1114	1075	1009	856	904	---
	High	Black	CFM	1478	1426	1387	1334	1292	1247	1212	1148	1108	---
PAN548 (208/230-1-60)	Low ¹	Blue	CFM	1201	1159	1101	1062	1004	957	897	852	793	---
	Med-Low	Pink	CFM	1419	1364	1318	1258	1214	1160	1118	1053	1009	---
	Medium ²	Red	CFM	1678	1635	1602	1558	1513	1474	1438	1404	1349	---
	Med-High	Orange	CFM	1916	1881	1846	1810	1761	1722	1681	1647	1600	---
	High	Black	CFM	2093	2051	2024	1967	1947	1907	1854	1826	1749	---
PAN560 (208/230-1-60)	Low ¹	Blue	CFM	1320	1256	1211	1142	1096	1028	973	903	835	---
	Med-Low	Pink	CFM	1351	1295	1258	1212	1170	1124	1080	1036	992	---
	Medium ²	Red	CFM	1824	1782	1742	1711	1673	1641	1607	1563	1490	---
	Med-High	Orange	CFM	2001	1958	1923	1883	1831	1776	1705	1624	1538	---
	High	Black	CFM	2292	2238	2158	2049	1935	1840	1732	1635	1513	---

* Air delivery values are without air filter and are for dry coil (See PAN5 Wet Coil Pressure Drop Table).

¹ Factory-shipped low stage cooling speed

² Factory-shipped high stage cooling speed

NOTE: Deduct field-supplied air filter pressure drop and wet coil pressure drop to obtain external static pressure available for ducting.

FILTER PRESSURE DROP

FILTER SIZE	CFM																			
	500	600	700	800	900	1000	1100	1200	1300	1400	1500	1600	1700	1800	1900	2000	2100	2200	2300	
	Pressure Drop (inches water column)																			
20 x 24 x 1	---	---	---	---	0.09	0.1	0.11	0.13	0.14	0.15	0.16	---	---	---	---	---	---	---	---	---
24 x 30 x 1	---	---	---	---	---	---	---	0.07	0.08	0.09	0.1	0.11	0.12	0.13	0.14	0.15	0.16	0.17	0.18	0.18
24 x 36 x 1	---	---	---	---	---	---	---	0.06	0.07	0.07	0.08	0.09	0.09	0.10	0.11	0.12	0.13	0.14	0.14	0.14

Minimum Filter Requirements:

20 x 24 x 1 = PAN524

24 x 30 x 1 = PAN536

24 x 36 x 1 = PAN548, PAN560

WET COIL PRESSURE DROP (in wc)

Unit Size	STANDARD CFM (SCFM)															
	600	700	800	900	1000	1100	1200	1300	1400	1500	1600	1700	1800	1900	2000	2100
24	0.005	0.007	0.010	0.012	0.015	-	-	-	-	-	-	-	-	-	-	-
36	-	-	-	0.019	0.023	0.027	0.032	0.037	0.042	0.047	-	-	-	-	-	-
48	-	-	-	-	-	-	0.027	0.032	0.036	0.041	0.046	0.052	0.057	0.063	0.068	-
60	-	-	-	-	-	-	-	-	-	0.029	0.032	0.036	0.040	0.045	0.049	0.053

Electric Heat Pressure Drop Table (in wc) – Small Cabinet: 24 cfm

	500	600	700	800	900	1000	1100	1200	1300	1400	1500	1600
5kw	0.00	0.00	0.00	0.00	0.00	0.00	0.00	0.00	0.02	0.04	0.06	0.07
7.2 kw	0.00	0.00	0.00	0.00	0.00	0.00	0.02	0.03	0.05	0.07	0.08	0.09
10 kw	0.00	0.00	0.00	0.00	0.00	0.02	0.04	0.06	0.07	0.09	0.10	0.11
15 kw	0.00	0.00	0.00	0.02	0.04	0.06	0.08	0.10	0.12	0.14	0.16	0.18

Electric Heat Pressure Drop Table (in wc) – Large Cabinet 36–60 cfm

	1100	1200	1300	1400	1500	1600	1700	1800	1900	2000	2100	2200	2300	2400	2500
5kw	0.00	0.00	0.00	0.01	0.02	0.03	0.04	0.05	0.06	0.07	0.08	0.09	0.10	0.11	0.12
7.2 kw	0.00	0.00	0.01	0.02	0.03	0.04	0.05	0.06	0.07	0.08	0.09	0.10	0.11	0.12	0.13
10 kw	0.00	0.00	0.01	0.02	0.03	0.04	0.05	0.06	0.07	0.08	0.09	0.10	0.11	0.12	0.13
15 kw	0.00	0.02	0.03	0.04	0.05	0.06	0.07	0.08	0.09	0.10	0.11	0.12	0.13	0.14	0.15
20 kw	0.02	0.03	0.04	0.05	0.06	0.07	0.08	0.09	0.10	0.11	0.12	0.13	0.14	0.15	0.16

ELECTRIC HEATER USAGE, 208/230-1-60

Electric Heater Model Number	Nominal Capacity (kW)	Fuses	Used With PAN5 Model Sizes			
			24	36	48	60
EHNA05K0N	5.0	0	✓	✓	✓	✓
EHNA05K4F	5.0	4	✓	✓	✓	✓
EHNA07K0N	7.5	0	✓	✓	✓	✓
EHNA07K4F	7.5	4	✓	✓	✓	✓
EHNA10K0N	10.0	0	✓	✓		
EHNA10K4F	10.0	4	✓	✓	✓	✓
EHNA15K6F	15.0	6		✓	✓	✓
EHNA20K6F	20.0	6			✓	✓

ELECTRICAL DATA

Unit	Nominal V-PH-HZ	Voltage Range		Compressor		OFM	IFM	Electric Heat		Single Point Power Supply	
		Min.	Max.	RLA	LRA	FLA	FLA	Nominal kW*	FLA	MCA	MOCPP
PAN524	208/230-1-60	187	253	10.3	52	0.9	4.3	-/-	-/-	18.0/18.0	25/25
								3.8/5.0	18.1/20.8	27.9/31.4	30/35
								5.4/7.2	26.0/30.0	37.9/42.9	40/45
								7.5/10.0	36.1/41.7	50.5/57.5	60/60
PAN536	208/230-1-60	187	253	16.7	82	0.9	6.8	-/-	-/-	28.5/28.2	45/45
								3.8/5.0	18.1/20.8	31.1/34.5	45/45
								5.4/7.2	26.0/30.0	41.0/46.0	45/50
								7.5/10.0	36.1/41.7	53.6/60.6	60/70
PAN548	208/230-1-60	187	253	21.2	96	1.5	6.8	-/-	-/-	34.7/34.7	50/50
								3.8/5.0	18.1/20.8	34.7/34.7	50/50
								5.4/7.2	26.0/30.0	41.0/46.0	50/50
								7.5/10.0	36.1/41.7	53.6/60.6	60/70
PAN560	208/230-1-60	187	253	25.6	118	1.9	9.1	-/-	-/-	43.1/43.1	60/60
								3.8/5.0	18.1/20.8	43.1/43.1	60/60
								5.4/7.2	26.0/30.0	43.9/48.9	60/60
								7.5/10.0	36.1/41.7	56.5/63.5	60/70
								11.3/15.0	54.2/62.5	79.1/89.5	80/90
								15.0/20.0	72.2/83.3	101.6/115.5	110/125

LEGEND

- FLA -- Full Load Amps
- LRA -- Locked Rotor Amps
- MCA -- Minimum Circuit Amps
- MOCPP -- Maximum Overcurrent Protection
- RLA -- Rated Load Amps



EXAMPLE: Supply voltage is 230-3-60.

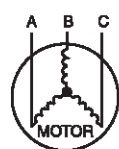

- AB = 228 v
- BC = 231 v
- AC = 227 v

$$\text{Average Voltage} = \frac{228 + 231 + 227}{3} = \frac{686}{3} = 229$$

Determine maximum deviation from average voltage.

- (AB) 229 - 228 = 1 v
- (BC) 231 - 229 = 2 v
- (AC) 229 - 227 = 2 v

Maximum deviation is 2 v.

Determine percent of voltage imbalance

$$\% \text{ Voltage Imbalance} = 100 \times \frac{2}{229} = 0.8\%$$

This amount of phase imbalance is satisfactory as it is below the maximum allowable 2%.

IMPORTANT: If the supply voltage phase imbalance is more than 2%, contact your local electric utility company immediately.

NOTES:

1. In compliance with NEC (National Electrical Code) requirements for multimotor and combination load equipment (refer to NEC Articles 430 and 440), the overcurrent protective device for the unit shall be Power Supply fuse. The CGA (Canadian Gas Association) units may be fuse or circuit breaker.
2. Minimum wire size is based on 60 C copper wire. If other than 60 C wire is used, or if length exceeds wire length in table, determine size from NEC.
3. Unbalanced 3-Phase Supply Voltage
Never operate a motor where a phase imbalance in supply voltage is greater than 2%. Use the following formula to determine the percentage of voltage imbalance

$$\% \text{ Voltage imbalance} = 100 \times \frac{\text{max voltage deviation from average voltage}}{\text{average voltage}}$$

PAN524 EXTENDED COOLING PERFORMANCE – HIGH COOL																							
EVAPORATOR AIR				CONDENSER ENTERING AIR TEMPERATURES deg F																			
				75 (23.8°C)				85 (29.4°C)				95 (35°C)				105 (40.5°C)				115 (46.1°C)			
CFM	EWB	Capacity MBtuh		Total System KW	Capacity MBtuh		Total System KW	Capacity MBtuh		Total System KW	Capacity MBtuh		Total System KW	Capacity MBtuh		Total System KW	Capacity MBtuh		Total System KW				
		Total	Sens		Total	Sens		Total	Sens		Total	Sens		Total	Sens		Total	Sens		Total	Sens		
700	57	21.77	21.77	1.61	20.88	20.88	1.79	19.95	19.95	2.00	18.94	18.94	2.23	17.86	17.86	2.48	16.66	16.66	2.77				
	62	22.40	18.69	1.61	21.29	18.21	1.80	20.13	17.70	2.00	18.95	18.95	2.23	17.86	17.86	2.48	16.66	16.66	2.77				
	63	22.85	15.18	1.62	21.71	14.70	1.80	20.52	14.21	2.01	19.25	13.70	2.23	17.90	13.16	2.48	16.42	12.58	2.77				
	67	24.66	15.72	1.64	23.44	15.24	1.83	22.15	14.75	2.03	20.79	14.24	2.26	19.34	13.70	2.51	17.74	13.12	2.79				
	72	27.16	12.75	1.67	25.83	12.28	1.86	24.42	11.80	2.06	22.94	11.29	2.29	21.33	10.76	2.54	19.57	10.18	2.83				
800	57	22.76	22.76	1.64	21.81	21.81	1.82	20.81	20.81	2.03	19.74	19.74	2.26	18.58	18.58	2.51	17.29	17.29	2.80				
	62	22.97	20.16	1.64	21.84	21.76	1.82	20.81	20.81	2.03	19.74	19.74	2.26	18.58	18.58	2.51	17.29	17.29	2.80				
	63	23.39	16.20	1.64	22.19	15.71	1.83	20.94	15.21	2.03	19.62	14.69	2.26	18.22	14.14	2.51	16.69	13.54	2.79				
	67	25.22	16.81	1.67	23.94	16.32	1.85	22.60	15.82	2.05	21.18	15.30	2.28	19.67	14.74	2.53	18.01	14.14	2.82				
	72	27.77	13.43	1.70	26.37	12.96	1.88	24.90	12.48	2.09	23.35	11.95	2.31	21.66	11.41	2.57	20.60	11.05	2.57				

PAN524 EXTENDED COOLING PERFORMANCE – LOW COOL																							
EVAPORATOR AIR				CONDENSER ENTERING AIR TEMPERATURES deg F																			
				75 (23.8°C)				85 (29.4°C)				95 (35°C)				105 (40.5°C)				115 (46.1°C)			
CFM	EWB	Capacity MBtuh		Total System KW	Capacity MBtuh		Total System KW	Capacity MBtuh		Total System KW	Capacity MBtuh		Total System KW	Capacity MBtuh		Total System KW	Capacity MBtuh		Total System KW				
		Total	Sens		Total	Sens		Total	Sens		Total	Sens		Total	Sens		Total	Sens		Total	Sens		
525	57	16.65	16.65	1.05	15.95	15.95	1.20	15.21	15.21	1.37	14.40	14.40	1.57	13.52	13.52	1.80	12.55	12.55	2.07				
	62	17.20	14.47	1.06	16.29	14.07	1.21	15.34	13.65	1.37	14.40	14.40	1.57	13.52	13.52	1.80	12.55	12.55	2.07				
	63	17.61	11.75	1.06	16.69	11.36	1.21	15.70	10.96	1.38	14.64	10.53	1.57	13.50	10.07	1.80	12.27	9.58	2.06				
	67	19.23	12.26	1.08	18.23	11.87	1.22	17.18	11.47	1.39	16.05	11.03	1.58	14.83	10.58	1.81	13.50	10.09	2.07				
	72	21.48	10.05	1.09	20.41	9.66	1.24	19.26	9.26	1.41	18.02	8.84	1.60	16.69	8.39	1.83	15.24	7.90	2.09				
600	57	17.52	17.52	1.08	16.77	16.77	1.23	15.96	15.96	1.39	15.10	15.10	1.59	14.15	14.15	1.82	13.11	13.11	2.09				
	62	17.71	15.66	1.08	16.78	16.75	1.23	15.96	15.96	1.39	15.10	15.10	1.59	14.15	14.15	1.82	13.12	13.12	2.09				
	63	18.10	12.58	1.08	17.12	12.18	1.23	16.09	11.76	1.39	14.98	11.32	1.59	13.80	10.85	1.81	12.51	10.35	2.08				
	67	19.75	13.14	1.09	18.71	12.74	1.24	17.60	12.32	1.41	16.41	11.88	1.60	15.14	11.41	1.83	13.76	10.91	2.09				
	72	22.06	10.61	1.11	20.93	10.21	1.26	19.72	9.80	1.43	18.41	9.36	1.62	17.03	8.91	1.85	15.51	8.41	2.11				

SPECIFICATIONS SUBJECT TO CHANGE WITHOUT NOTICE

PAN536 EXTENDED COOLING PERFORMANCE – HIGH COOL

EVAPORATOR AIR		CONDENSER ENTERING AIR TEMPERATURES deg F																	
		75 (23.8°C)			85 (29.4°C)			95 (35°C)			105 (40.5°C)			115 (46.1°C)			125 (51.6°C)		
CFM	EWB	Capacity MBtuh		Total System KW	Capacity MBtuh		Total System KW	Capacity MBtuh		Total System KW	Capacity MBtuh		Total System KW	Capacity MBtuh		Total System KW	Capacity MBtuh		Total System KW
		Total	Sens		Total	Sens		Total	Sens		Total	Sens		Total	Sens		Total	Sens	
1050	57	33.64	33.64	2.28	32.32	32.32	2.53	30.90	30.90	2.81	29.36	29.36	3.11	27.65	27.65	3.46	25.71	25.71	3.84
	62	34.47	28.72	2.29	32.83	28.00	2.54	31.11	27.24	2.81	29.36	29.36	3.11	27.65	27.65	3.46	25.71	25.71	3.84
	63	35.12	23.25	2.29	33.44	22.56	2.54	31.65	21.83	2.81	29.73	21.07	3.12	27.64	20.25	3.45	25.33	19.35	3.83
	67	37.76	24.04	2.32	35.94	23.34	2.57	34.00	22.61	2.84	31.91	21.83	3.15	29.65	21.00	3.49	27.14	20.10	3.87
	73	42.16	18.41	2.37	40.12	17.73	2.62	37.93	17.01	2.90	35.58	16.24	3.20	33.02	15.43	3.54	30.21	14.53	3.92
1200	57	35.06	35.06	2.32	33.64	33.64	2.58	32.12	32.12	2.85	30.46	30.46	3.16	28.63	28.63	3.50	26.56	26.56	3.89
	62	35.29	30.91	2.33	33.64	33.64	2.58	32.12	32.12	2.85	30.46	30.46	3.16	28.63	28.63	3.50	26.56	26.56	3.89
	63	35.86	24.79	2.33	34.09	24.08	2.58	32.22	23.34	2.85	30.23	22.56	3.15	28.05	21.71	3.49	25.66	20.78	3.87
	67	38.52	25.68	2.36	36.62	24.97	2.61	34.60	24.22	2.88	32.43	23.43	3.19	30.06	22.57	3.53	27.47	21.64	3.90
	73	42.99	19.31	2.41	40.85	18.61	2.66	38.57	17.87	2.93	36.13	17.09	3.24	33.48	16.25	3.58	30.56	15.35	3.96

PAN536 EXTENDED COOLING PERFORMANCE – LOW COOL

EVAPORATOR AIR		CONDENSER ENTERING AIR TEMPERATURES deg F																	
		75 (23.8°C)			85 (29.4°C)			95 (35°C)			105 (40.5°C)			115 (46.1°C)			125 (51.6°C)		
CFM	EWB	Capacity MBtuh		Total System KW	Capacity MBtuh		Total System KW	Capacity MBtuh		Total System KW	Capacity MBtuh		Total System KW	Capacity MBtuh		Total System KW	Capacity MBtuh		Total System KW
		Total	Sens		Total	Sens		Total	Sens		Total	Sens		Total	Sens		Total	Sens	
745	57	23.27	23.27	1.46	22.34	22.34	1.65	21.31	21.31	1.87	20.19	20.19	2.12	18.95	18.95	2.41	17.58	17.58	2.76
	62	23.91	20.06	1.46	22.70	19.54	1.65	21.41	18.97	1.87	20.19	20.19	2.12	18.95	18.95	2.41	17.58	17.58	2.76
	63	24.46	16.28	1.47	23.21	15.77	1.66	21.87	15.23	1.87	20.42	14.65	2.12	18.85	14.03	2.41	17.14	13.36	2.75
	67	26.63	16.96	1.48	25.29	16.45	1.67	23.85	15.90	1.89	22.28	15.32	2.14	20.58	14.69	2.43	18.72	14.02	2.77
	72	29.67	13.86	1.51	28.20	13.35	1.70	26.61	12.81	1.91	24.89	12.23	2.16	23.01	11.60	2.45	20.96	10.93	2.79
850	57	24.45	24.45	1.48	23.43	23.43	1.67	22.33	22.33	1.89	21.11	21.11	2.14	19.80	19.80	2.44	18.32	18.32	2.78
	62	24.61	21.68	1.48	23.43	23.43	1.67	22.33	22.33	1.89	21.12	21.12	2.14	19.80	19.80	2.44	18.32	18.32	2.78
	63	25.11	17.42	1.49	23.80	16.89	1.68	22.39	16.34	1.89	20.88	15.74	2.14	19.24	15.10	2.43	17.46	14.42	2.77
	67	27.33	18.17	1.50	25.92	17.64	1.69	24.40	17.08	1.91	22.76	16.48	2.15	20.99	15.84	2.44	19.06	15.15	2.78
	72	30.44	14.64	1.53	28.89	14.12	1.71	27.21	13.55	1.93	25.40	12.96	2.17	23.45	12.33	2.46	21.30	11.65	2.80

6

519 56 1901 02

PAN548 EXTENDED COOLING PERFORMANCE – HIGH COOL

EVAPORATOR AIR		CONDENSER ENTERING AIR TEMPERATURES deg F																	
		75 (23.8°C)			85 (29.4°C)			95 (35°C)			105 (40.5°C)			115 (46.1°C)			125 (51.6°C)		
CFM	EWB	Capacity MBtuh		Total System KW	Capacity MBtuh		Total System KW	Capacity MBtuh		Total System KW	Capacity MBtuh		Total System KW	Capacity MBtuh		Total System KW	Capacity MBtuh		Total System KW
		Total	Sens		Total	Sens		Total	Sens		Total	Sens		Total	Sens		Total	Sens	
1400	57	44.39	44.39	3.40	42.70	42.70	3.71	40.87	40.87	4.05	38.88	38.88	4.43	36.67	36.67	4.84	34.16	34.16	5.30
	62	45.43	38.20	3.41	43.33	37.29	3.72	41.11	36.31	4.05	38.87	38.87	4.43	36.67	36.67	4.84	35.30	35.30	4.84
	63	46.29	30.85	3.42	44.11	29.95	3.73	41.79	29.00	4.06	39.28	28.00	4.43	36.54	26.91	4.84	33.51	25.73	5.29
	67	50.04	32.01	3.46	47.71	31.11	3.77	45.21	30.16	4.11	42.50	29.14	4.48	41.00	28.60	4.43	36.24	26.85	5.34
	72	55.24	25.88	3.53	52.68	24.98	3.84	49.93	24.04	4.18	46.96	23.04	4.55	45.43	22.53	4.52	40.04	20.75	5.41
1600	57	46.32	46.32	3.48	44.10	44.10	3.79	42.54	42.54	4.13	40.41	40.41	4.51	38.04	38.04	4.92	36.62	36.62	4.93
	62	46.57	41.09	3.48	44.43	44.43	3.79	42.54	42.54	4.13	41.40	41.40	4.51	38.04	38.04	4.92	36.61	36.61	4.93
	63	47.25	32.81	3.49	44.97	31.89	3.80	42.55	30.92	4.13	39.95	29.90	4.50	37.11	28.80	4.91	33.97	27.59	5.36
	67	51.07	34.10	3.53	48.62	33.18	3.84	46.00	32.20	4.18	43.19	31.17	4.55	40.12	30.06	4.96	38.36	29.43	4.97
	72	56.36	27.17	3.60	53.67	26.25	3.91	50.80	25.29	4.25	47.69	24.26	4.62	44.30	23.15	5.03	42.55	22.59	5.06

PAN548 EXTENDED COOLING PERFORMANCE – LOW COOL

EVAPORATOR AIR		CONDENSER ENTERING AIR TEMPERATURES deg F																	
		75 (23.8°C)			85 (29.4°C)			95 (35°C)			105 (40.5°C)			115 (46.1°C)			125 (51.6°C)		
CFM	EWB	Capacity MBtuh		Total System KW	Capacity MBtuh		Total System KW	Capacity MBtuh		Total System KW	Capacity MBtuh		Total System KW	Capacity MBtuh		Total System KW	Capacity MBtuh		Total System KW
		Total	Sens		Total	Sens		Total	Sens		Total	Sens		Total	Sens		Total	Sens	
965	57	31.49	31.49	2.22	30.30	30.30	2.49	29.02	29.02	2.78	27.63	27.63	3.12	26.10	26.10	3.51	24.40	24.40	3.96
	62	32.49	27.41	2.21	30.96	26.74	2.48	29.34	26.03	2.78	27.64	27.57	3.12	26.10	26.10	3.51	24.40	24.40	3.97
	63	33.19	22.28	2.21	31.62	21.62	2.48	29.95	20.92	2.78	28.14	20.18	3.12	26.19	19.39	3.52	24.04	18.53	3.97
	67	36.14	23.21	2.21	34.45	22.54	2.47	32.65	21.84	2.77	30.72	21.10	3.10	28.62	20.30	3.49	26.31	19.44	3.94
	72	40.19	19.02	2.21	38.34	18.36	2.46	36.37	17.67	2.75	34.25	16.93	3.08	31.95	16.14	3.46	29.40	15.29	3.90
1100	57	33.04	33.04	2.24	31.76	31.76	2.50	30.39	30.39	2.80	28.90	28.90	3.13	27.27	27.27	3.52	25.45	25.45	3.97
	62	33.42	29.57	2.23	31.85	28.86	2.50	30.39	30.39	2.80	28.90	28.90	3.13	27.27	27.27	3.52	25.45	25.45	3.97
	63	34.05	23.76	2.23	32.40	23.08	2.50	30.64	22.37	2.80	28.77	21.61	3.14	26.73	20.81	3.53	24.50	19.92	3.99
	67	37.06	24.78	2.23	35.29	24.10	2.49	33.40	23.38	2.78	31.39	22.62	3.12	29.20	21.81	3.51	26.79	20.93	3.95
	72	41.21	20.03	2.23	39.26	19.35	2.48	37.19	18.64	2.77	34.96	17.88	3.10	32.54	17.07	3.48	29.89	16.19	3.92

PAN560 EXTENDED COOLING PERFORMANCE – HIGH COOL

EVAPORATOR AIR		CONDENSER ENTERING AIR TEMPERATURES deg F																	
		75 (23.8°C)			85 (29.4°C)			95 (35°C)			105 (40.5°C)			115 (46.1°C)			125 (51.6°C)		
CFM	EWB	Capacity MBtuh		Total System KW	Capacity MBtuh		Total System KW	Capacity MBtuh		Total System KW	Capacity MBtuh		Total System KW	Capacity MBtuh		Total System KW	Capacity MBtuh		Total System KW
		Total	Sens		Total	Sens		Total	Sens		Total	Sens		Total	Sens		Total	Sens	
2000	57	58.24	58.24	4.41	55.10	55.10	4.84	54.80	54.80	4.69	52.40	52.40	5.23	46.70	46.70	6.40	42.90	42.90	7.02
	62	58.46	54.46	4.42	55.79	55.79	4.84	55.36	55.36	4.69	52.73	52.73	5.23	46.94	46.94	6.40	43.20	43.20	7.02
	63	59.23	43.33	4.42	56.27	42.07	4.85	55.68	41.83	4.69	52.48	40.49	5.22	45.80	37.74	6.37	41.56	36.02	6.97
	67	63.56	44.86	4.50	60.35	43.59	4.92	56.88	42.24	5.38	56.62	42.14	5.33	48.97	39.21	6.44	44.37	37.49	7.05
	72	69.55	35.33	4.59	66.01	34.07	5.02	62.20	32.73	5.48	58.07	31.30	5.99	53.51	29.74	6.54	48.46	28.03	7.15
1750	57	56.01	56.01	4.29	53.76	53.76	4.72	51.30	51.30	5.19	50.80	50.80	5.08	45.20	45.20	6.27	41.70	41.70	6.89
	62	57.19	50.62	4.31	54.45	49.37	4.73	51.51	48.01	5.19	50.93	47.74	5.08	45.50	45.50	6.27	41.99	41.99	6.89
	63	58.18	40.75	4.32	55.35	39.51	4.74	52.28	38.20	5.20	51.66	37.95	5.10	45.27	35.27	6.26	41.16	33.59	6.87
	67	62.48	42.11	4.39	59.41	40.86	4.81	57.00	39.90	5.18	55.71	39.39	5.21	48.47	36.58	6.34	44.00	34.88	6.94
	72	68.41	33.69	4.48	65.01	32.46	4.91	61.35	31.14	5.37	57.37	29.72	5.88	52.97	28.19	6.44	48.09	26.53	7.04

PAN560 EXTENDED COOLING PERFORMANCE – LOW COOL

EVAPORATOR AIR		CONDENSER ENTERING AIR TEMPERATURES deg F																	
		75 (23.8°C)			85 (29.4°C)			95 (35°C)			105 (40.5°C)			115 (46.1°C)			125 (51.6°C)		
CFM	EWB	Capacity MBtuh		Total System KW	Capacity MBtuh		Total System KW	Capacity MBtuh		Total System KW	Capacity MBtuh		Total System KW	Capacity MBtuh		Total System KW	Capacity MBtuh		Total System KW
		Total	Sens		Total	Sens		Total	Sens		Total	Sens		Total	Sens		Total	Sens	
1200	57	39.88	39.88	2.70	38.34	38.34	3.04	36.64	36.64	3.43	34.74	34.74	3.87	31.90	31.90	4.37	29.70	29.70	4.94
	62	40.94	35.96	2.69	39.01	35.09	3.04	36.90	34.14	3.43	34.90	34.90	3.87	32.60	32.60	4.37	30.16	30.16	4.94
	63	41.76	29.14	2.69	39.78	28.27	3.04	37.61	27.34	3.42	35.23	26.33	3.87	32.61	25.22	4.37	29.69	24.04	4.96
	67	45.04	30.17	2.68	42.87	29.29	3.02	40.50	28.35	3.40	37.91	27.31	3.84	35.04	26.21	4.33	31.84	25.00	4.90
	72	49.59	24.40	2.68	47.18	23.52	3.01	44.52	22.56	3.38	41.68	21.55	3.80	38.47	20.43	4.28	34.93	19.21	4.84
1370	57	41.69	41.69	2.72	40.00	40.00	3.07	37.90	37.90	3.45	35.45	35.45	3.89	33.62	33.62	4.38	30.90	30.90	4.95
	62	41.98	38.83	2.72	40.02	40.02	3.07	38.18	38.18	3.45	36.13	36.13	3.89	33.82	33.82	4.38	31.19	31.19	4.95
	63	42.72	31.09	2.72	40.63	30.20	3.07	38.35	29.24	3.45	35.86	28.21	3.89	33.13	27.09	4.40	30.10	25.87	4.98
	67	46.03	32.23	2.72	43.75	31.34	3.05	41.27	30.36	3.43	38.55	29.32	3.86	35.56	28.18	4.36	32.25	26.93	4.92
	72	50.62	25.68	2.71	48.09	24.78	3.04	45.37	23.83	3.41	42.32	22.77	3.83	39.01	21.64	4.31	35.34	20.40	4.86

* 63°F Ewb is at 75°F entering dry bulb – Tennessee Valley Authority [TVA] rating conditions; all others at 80°F entering dry bulb.

LEGEND: BF — Bypass Factor Ewb — Entering Wet Bulb kW — Total Unit Power Input SHC — Sensible Heat Capacity (x1000 Btuh) TC — Total Capacity (x1000 Btuh) (net)

NOTES:

1. Ratings are net; they account for the effects of the evaporator fan motor power and heat.
2. Direct interpolation is permissible. Do not extrapolate.
3. The following formulas may be used:

$$t_{Ldb} = t_{Edb} - \frac{\text{Sensible Capacity (BTU/h)}}{1.10 \times \text{cfm}} \qquad h_{Lwb} = h_{Ewb} - \frac{\text{Total Capacity (BTU/h)}}{4.5 \times \text{cfm}}$$

Where: h_{Ewb} = Enthalpy of air entering evaporator coil

t_{Lwb} = Wet bulb temperature corresponding to enthalpy of air leaving evaporator coil (h_{Lwb})

4. The SHC is based on 80°F Edb temperature of air entering evaporator coil.
 Below 80°F Edb, subtract (corr factor x cfm) from SHC.
 Above 80°F Edb, add (corr factor x cfm) to SHC. Correction Factor = $1.10 \times (1 + BF) \times (Edb + 80)$.

ACCESSORIES

ROOF CURBS

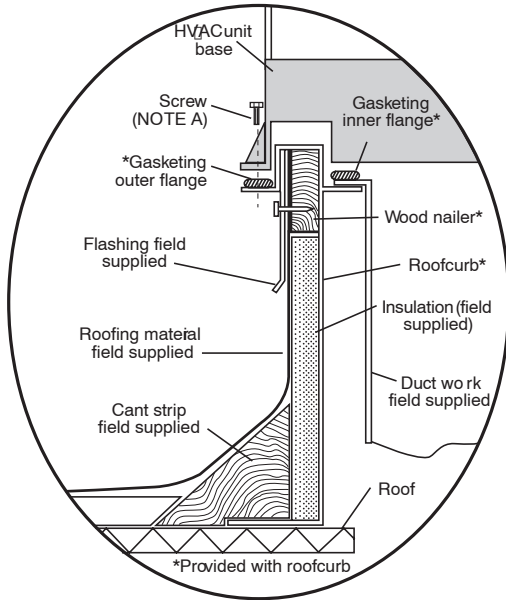

Roof Curb for Small Cabinet

Note A: When unit mounting screw is used, retainer bracket must also be used.

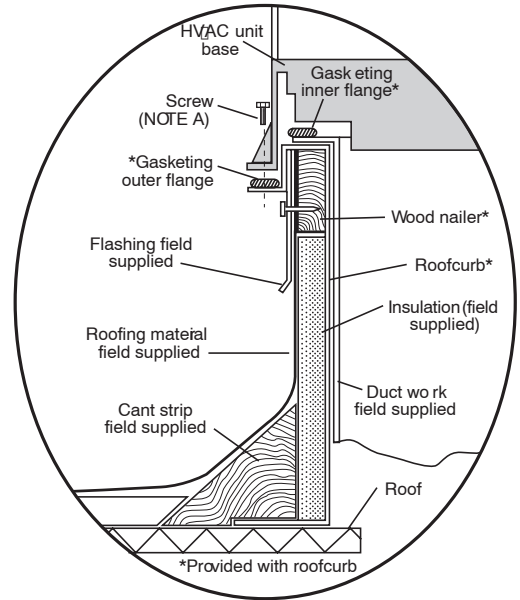

Roof Curb for Large Cabinet

Note A: When unit mounting screw is used, retainer bracket must also be used.

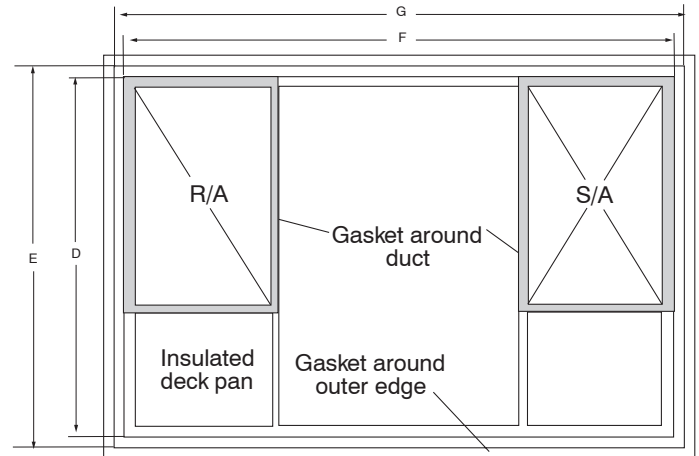
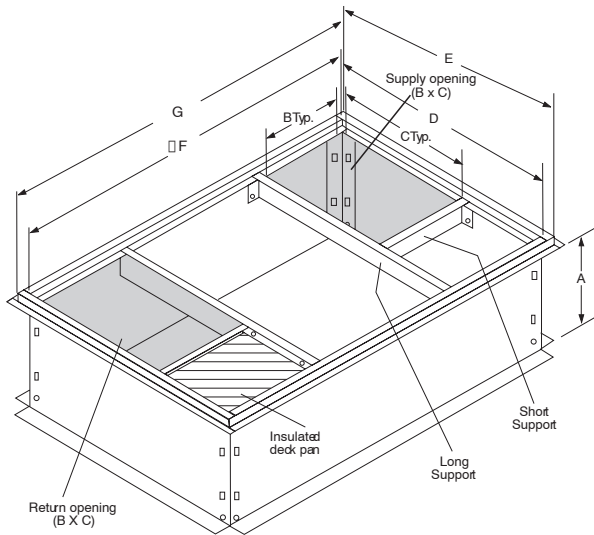

UNIT SIZE	MODEL NUMBER	A IN. [MM]	B IN. [MM]	C IN. [MM]	D IN. [MM]	E IN. [MM]	F IN. [MM]	G IN. [MM]
24	NPRFCURB006A00	8 [203]	11 [279]	16-1/2 [419]	28-3/4 [730]	30-3/8 [771]	44-5/16 [1126]	45-15/16 [1167]
	NPRFCURB007A00	14 [356]	11 [279]	16-1/2 [419]	28-3/4 [730]	30-3/8 [771]	44-5/16 [1126]	45-15/16 [1167]
36-60	NPRFCURB008A00	8 [203]	16-3/16 [411]	17-3/8 [441]	40-1/4 [1022]	41-15/16 [1065]	44-7/16 [1129]	46-1/16 [1169]
	NPRFCURB009A00	14 [356]	16-3/16 [411]	17-3/8 [441]	40-1/4 [1022]	41-15/16 [1065]	44-7/16 [1129]	46-1/16 [1169]

Notes:

1. Seal strip must be applied as required to unit being installed.
2. Roof curb is made of 16 gauge steel.
3. Attach ductwork to curb (flanges of duct rest on curb).
4. Insulated panels: 1-in. thick fiberglass 1 lb. density.
5. When unit mounting screw is used (see Note A), a retainer bracket must be used as well. This bracket must also be used when required by code for hurricane or seismic conditions. This bracket is available through Micrometl.

ACCESSORIES (continued)

ROOF CURBS

Model Number	Description	Use With Model Size
NPRFCURB006A00	8" High Roof Curb	24, 30, 36
NPRFCURB007A00	14" High Roof Curb	24, 30, 36
NPRFCURB008A00	8" High Roof Curb	42, 48, 60
NPRFCURB009A00	14" High Roof Curb	42, 48, 60

ECONOMIZERS

Model Number	Description	Use With Model Size
NPECOMZR003A00	Vertical or Horizontal, internal with solid state controller, fully modulating damper, up to 50% barometric relief *, supply and dry bulb outdoor air sensors, filter rack with 1-inch filters.**	24, 30, 36
NPECOMZR004A00		42
NPECOMZR006A00		48, 60
AXB078ENT	Outdoor Enthalpy Control	ALL

* Barometric relief only works in the down discharge application

** Outdoor enthalpy available as field installed accessory

MANUAL FRESH AIR DAMPERS

Model Number	Description	Use With Model Size
NPMANDPR004A00	Manual Outside Air Damper – External w/ filter rack and 1" filter	24, 30, 36
NPMANDPR005A00		42
NPMANDPR006A00		48, 60

INTERNAL FILTER RACK and FILTER (shipped with 1" filters)

Model Number	Description	Filter Size	Use With Model Size
NPFILTRK004A00	Horizontal or Downflow Internal Filter Rack	12" x 20" x 1" (quan. 2) or 12" x 20" x 2" (quan. 1) PLUS 10" x 20" x 2" (quan.1)	24, 30, 36
NPFILTRK005A00		12" x 24" x 1" or 2" (3 required)	42
NPFILTRK006A00		12" x 24" x 1" or 2" (3 required)	48, 60

CONCENTRIC DIFFUSER & DUCT TRANSITIONS

Model Number	Description	Use With Model Size
AXB030CSA	STEP DOWN – Fits 2' x 4' Ceiling Grid (Adpats round 18" duct)	ALL
AXB030CFA	FLUSH MOUNT – Fits 2' x 4' Ceiling Grid (Adapts round 18" duct)	ALL
NPDUCLG002A00	Square (14" x 16") to Round (14") – 1 set of 2, use with curb	30, 36, 42, 48

HIGH AND LOW PRESSURE SWITCH KIT, LOW AMBIENT, ANTI-CYCLE TIMER, COMPRESSOR START ASSIST

Model Number	Description	Use With Model Size
AXB035LAA	Low ambient Control – enables cooling system to operate down to 0 Deg. F by cycling condenser fan on and off	ALL
NRTIMEGD001A00	5 minute anti-cycle timer (Note: many thermostats have inherent anti-cycle timer logic)	ALL
NPHSTART001A00	PTC type compressor start assist	ALL

LIFTING / RIGGING KIT

Model Number	Description	Use With Model Size
NPLIFTBK003A10	For Rooftop Applications (Set of 10)	ALL

UNIT DIMENSIONS, model sizes 24

UNIT	ELECTRICAL CHARACTERISTICS	UNIT WT. LBS. KG.	UNIT HEIGHT "A" "A"	CENTER OF GRAVITY MM/IN		
				X	Y	Z
PAN524	218/230-1-80	353 154.5	1041, 91(41, 02)	508(20, 0)	489, 5(19, 3)	447, 0(17, 6)

REQUIRED CLEARANCES TO COMBUSTIBLE MATL.

TOP OF UNIT.....	INCHES [MM]
DUCT SIDE OF UNIT.....	14.00 [355.6]
SIDE OPPOSITE DUCT.....	2.00 [50.8]
BOTTOM OF UNIT.....	14.00 [355.6]
FLUE PANEL.....	0.00 [0.0]
.....	36.00 [914.4]

NEC. REQUIRED CLEARANCES

BETWEEN UNITS, POWER ENTRY SIDE.....	INCHES [MM]
UNIT AND UNGROUNDED SURFACES, POWER ENTRY SIDE.....	42.00 [1066.8]
UNIT AND UNGROUNDED SURFACES, POWER ENTRY SIDE.....	36.00 [914.0]
UNITS, POWER ENTRY SIDE AND OTHER GROUNDED SURFACES, POWER ENTRY SIDE.....	42.00 [1066.8]

REQUIRED CLEARANCE FOR OPERATION AND SERVICING

EWP, COIL ACCESS SIDE.....	INCHES [MM]
POWER ENTRY SIDE.....	42.00 [1066.8]
(EXCEPT FOR NEC REQUIREMENTS)	42.00 [1066.8]
UNIT TOP.....	48.00 [1219.2]
SIDE OPPOSITE DUCTS.....	36.00 [914.0]
DUCT PANEL.....	12.00 [304.8]

*MINIMUM DISTANCES: IF UNIT IS PLACED LESS THAN 12.00 [304.8] FROM WALL SYSTEM, THEN SYSTEM PERFORMANCE MAYBE COMPROMISED.

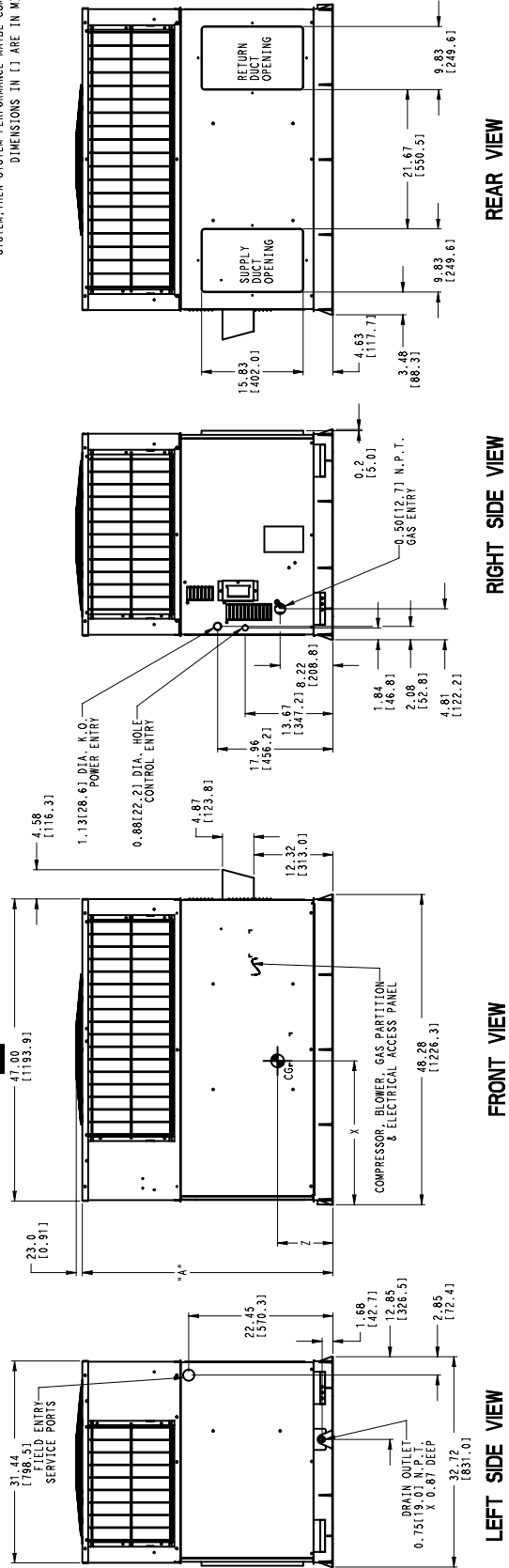

UNIT DIMENSIONS, model sizes 36, 48, 60

UNIT	ELECTRICAL CHARACTERISTICS		UNIT WGT.		UNIT HEIGHT		CENTER OF GRAVITY MM/IN		
	208/230-1-90	208/230-1-90	LOG.	KG.	H.	X	Z	Y	
PAN536	208/230-1-90	208/230-1-90	447	202.8	1142.5(44.58)	533.4(21.0)	527.7(20.75)	421.8(16.6)	7
PAN548	208/230-1-90	208/230-1-90	475	215.4	1153.3(45.38)	485.3(19.1)	538.8(21.2)	457.2(18.0)	
PAN560	208/230-1-90	208/230-1-90	528	238.5	1254.8(49.38)	533.4(21.0)	506.0(20.0)	447.5(17.6)	

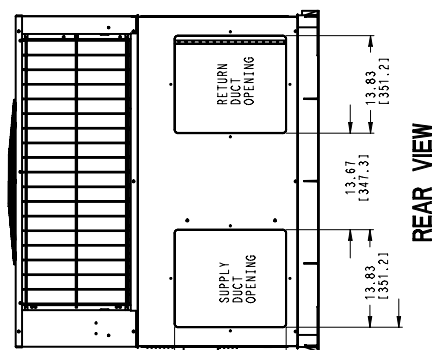
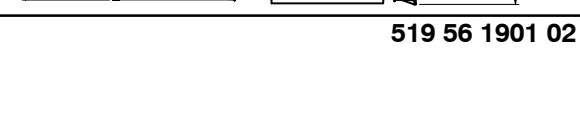
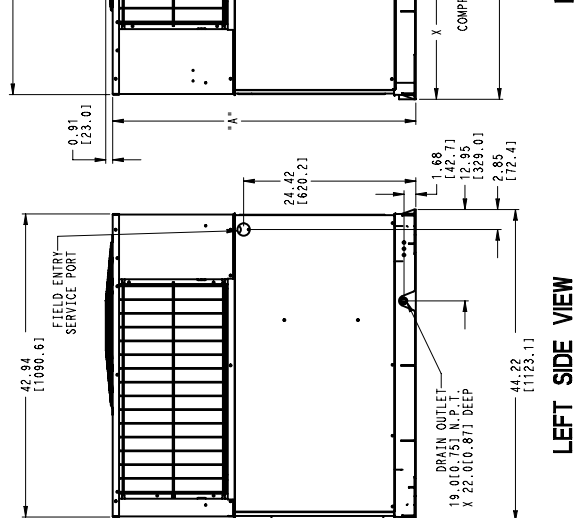
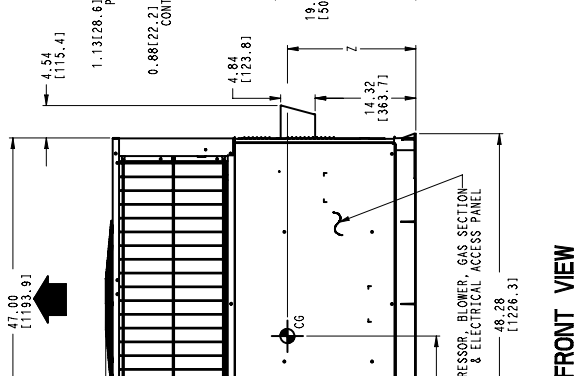
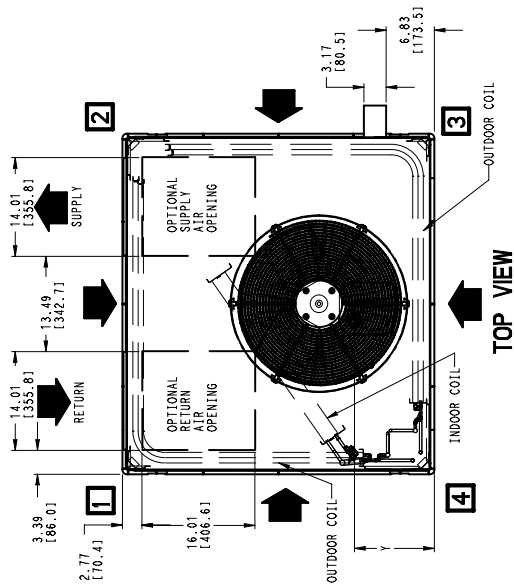

REQUIRED CLEARANCES TO COMBUSTIBLE MATL.

INCHES [MM]

TOP OF UNIT.....14.00 [355.6]

DUCT SIDE OF.....2.00 [50.8]

SIDE OPPOSITE DUCT.....14.00 [355.6]

BOTTOM OF UNIT.....6.00 [152.4]

FLUE PANEL.....36.00 [914.4]

NEC. REQUIRED CLEARANCES.

INCHES [MM]

BETWEEN UNITS, POWER ENTRY SIDE.....42.00 [1066.8]

AND UNBURNED SURFACES, POWER ENTRY SIDE.....36.00 [914.0]

UNIT AND UNBURNED SURFACES, RETURN SIDE.....42.00 [1066.8]

UNIT AND UNBURNED SURFACES, OTHER.....42.00 [1066.8]

GROUND SURFACES, POWER ENTRY SIDE.....42.00 [1066.8]

REQUIRED CLEARANCE FOR OPERATION AND SERVICING

INCHES [MM]

EVAP. COIL ACCESS SIDE.....0.00 [0.0]

POWER ENTRY SIDE.....42.00 [1066.8]

(EXCEPT FOR NEC REQUIREMENTS)

UNIT TOP.....48.00 [1219.2]

SIDE OPPOSITE DUCTS.....36.00 [914.0]

DUCT PANEL.....12.00 [304.8]

MINIMUM DISTANCES: IF UNIT IS PLACED LESS THAN 12.00 [304.8] FROM WALL SYSTEM, THEN SYSTEM PERFORMANCE MAYBE COMPROMISED.

DIMENSIONS IN [] ARE IN MILLIMETERS

GUIDE SPECIFICATIONS

CABINET

Unit cabinet shall be constructed of phosphated, zinc-coated, pre-painted steel capable of with-standing 500 hours in salt spray. Normal service shall be through a single removable cabinet panel. The unit shall be constructed on a rust proof unit base that has an externally trapped, integrated sloped drain.

Evaporator fan compartment top surface shall be insulated with a minimum 1/2-in. thick, flexible fiberglass insulation, coated on the air side and retained by adhesive and mechanical means. The evaporator wall sections will be insulated with a minimum semi-rigid foil-faced board capable of being wiped clean. Aluminum foil-faced fiberglass insulation shall be used in the entire indoor air cavity section.

COOLING SECTION

The unit is factory charged and operationally ready upon delivery. The unit refrigerant circuit has a high efficiency scroll compressor with internal overload protection, and copper tube / aluminum fin evaporator and condenser coils. The unit is designed for cooling operation to 40° F and will be capable of being wired for field installed economizer type accessories.

COILS

The evaporator and condenser coils are fabricated with aluminum fins mechanically bonded to copper tubing. Both coils are pressure tested prior to assembly into the unit and electronically leak tested after assembly into the unit.

CONDENSER FAN

The unit has a single direct-drive propeller-fan / motor assembly. The assembly is mounted directly to a vertical-discharge grille that is easily removed for service. Motors are 825 - 1100 RPM with sleeve or ball bearings and internal overload protection.

EVAPORATOR BLOWER

All units have a direct-drive X-13 evaporator blower motor as a standard. The direct-drive evaporator blower motor has sleeve bearings and internal overload protection.

CORNER WEIGHTS and RIGGING DETAILS

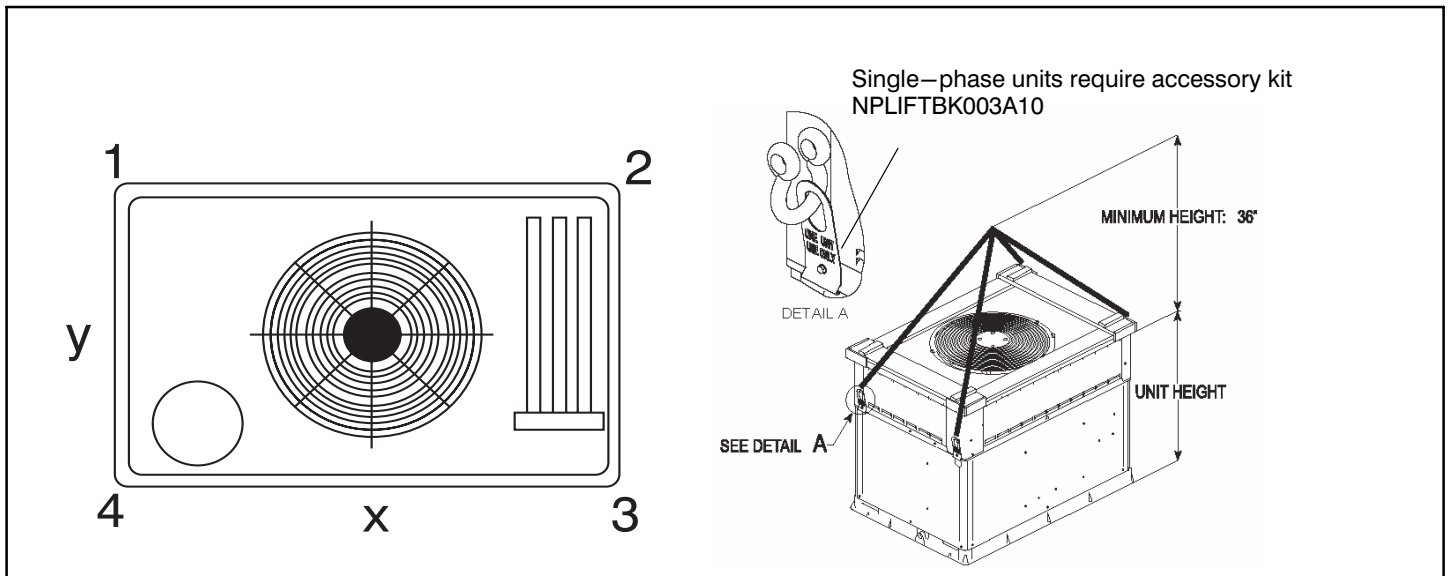

Cabinet	MODEL NUMBER	Rigging Weight		1		2		3		4	
		lb	kg	lb	kg	lb	kg	lb	kg	lb	kg
Small	PAN524	382	173	75	34	57	26	91	41	158	72
Large	PAN536	469	213	93	42	71	32	113	51	192	87
	PAN548	497	225	104	47	63	29	136	62	193	88
	PAN560	548	249	117	53	75	34	149	68	207	94

MODEL NOMENCLATURE

MODEL SERIES	P	A	N	5	36	000	K	00	A	1
P = Package										
A = Air Conditioner										
N = R-410A										
5 = 15				SEER						
24 = 24,000 BTUH = 2 Tons										
36 = 36,000 BTUH = 3 Tons										
48 = 48,000 BTUH = 4 Tons										
60 = 60,000 BTUH = 5 Tons					NOMINAL COOLING BTUH					
000 = No heat						NOMINAL HEATING BTUH				
K = 208/230-1-60							VOLTAGE			
00 = No Options								FACTORY INSTALLED OPTIONS		
Sales Model Digit										
Engineering Digit										