

**CRBTMPWR005A00  
CRBTMPWR006A00  
CRBTMPWR007A00**

**ACCESSORY THRU-THE-BOTTOM  
SERVICE CONNECTION  
FOR SELECT 7.5 TO 15 TON MODELS**

## Installation Instructions

**IMPORTANT:** Read and become familiar with all instructions before beginning installation.

### PACKAGE CONTENTS

QTY	CONTENTS
4	Cover Plates
2	Gaskets
4	Bulkhead Fittings
1	Bracket, Gas Pipe Supports
1	Bag of Screws

### PACKAGE USAGE

PACKAGE	POWER CONDUIT SIZE
CRBTMPWR005A00	1 <sup>1</sup> / <sub>4</sub> "
CRBTMPWR006A00	1 <sup>1</sup> / <sub>2</sub> "
CRBTMPWR007A00	2"

**NOTE:** See page 5 for Models and Sizes covered.

### SAFETY CONSIDERATIONS

Improper installation, adjustment, alteration, service, maintenance, or use can cause explosion, fire, electrical shock or other conditions which may cause personal injury or property damage. Consult a qualified installer, service agency, or your distributor or branch for information or assistance. The qualified installer or agency must use factory-authorized kits or accessories when modifying this product. Refer to the individual instructions packaged with the kits or accessories when installing.

Follow all safety codes. Wear safety glasses and work gloves. Use quenching cloths for brazing operations and have a fire extinguisher available. Read these instructions thoroughly and follow all warnings or cautions attached to the unit. Consult local building codes and appropriate national electrical codes (in USA, ANSI/NFPA70, National Electrical Code (NEC); in Canada, CSA C22.1) for special requirements.

It is important to recognize safety information. This is the safety-alert symbol . When you see this symbol on the unit and in instructions or manuals, be alert to the potential for personal injury.

Understand the signal words DANGER, WARNING, and CAUTION. These words are used with the safety-alert symbol. DANGER identifies the most serious hazards which **will** result in severe personal injury or death. WARNING signifies a hazard which **could** result in personal injury or death. CAUTION is used to identify unsafe practices which **may** result in minor personal injury or product and property damage. NOTE is used to highlight suggestions which **will** result in enhanced installation, reliability, or operation.

### **DANGER**

#### **FIRE AND EXPLOSION HAZARD**

Failure to follow these instructions will likely result in personal injury or death.

Before performing service or maintenance operations on or near a gas fired units' gas hardware or controls, always turn off the gas supply and install lockout tag.

### **WARNING**

#### **ELECTRICAL SHOCK HAZARD**

Failure to follow this warning could result in personal injury and/or death.

Before performing service or maintenance operations on the unit, always turn off main power switch(es) to unit and install lockout tag(s). Unit may have more than one power switch.

# ⚠ CAUTION

## CUT HAZARD

Failure to follow this caution may result in personal injury.

Sheet metal parts may have sharp edges or burrs. Use care and wear appropriate protective clothing, safety glasses and gloves when handling parts and servicing roof top units.

## GENERAL

Since the kits vary by only one digit of the part number they will hereafter be referred to by a three digit subset of their full part number containing that digit ("005", "006" "007").

Thru-the-bottom, power connection accessory packages reduce the number of penetrations in the roof. They provide a watertight way to connect power wiring, control wiring and the gas supply line through the base of the unit in the condenser section. The 3 thru-the-bottom power accessory packages vary only in the size of the main power conduit connection. They contain multiple cover plates and fittings from which you select the correct combination for your unit, as well as extra gaskets and screws. (See Fig. 1.) They are installed by replacing the existing solid cover plate in the outdoor section of the unit under the control panel. (See Fig. 2.) This cover plate may be replaced before or after unit installation on the roof.

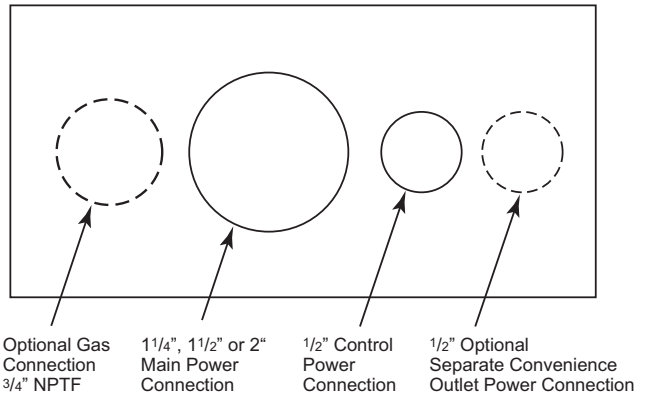

**Fig. 1 - Cover Plate Configuration (Not to Scale)**

C10386

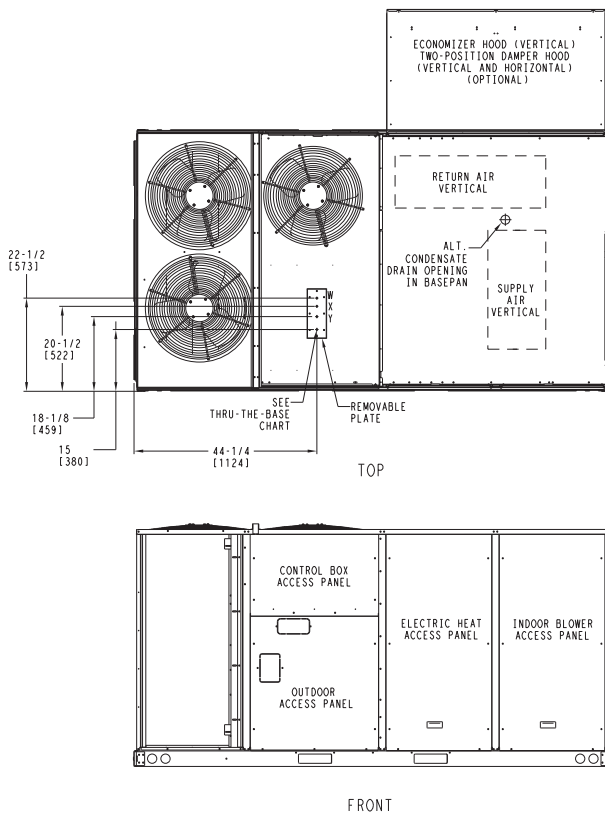

NOTE:  
DIMENSIONS ARE IN INCHES. DIMENSIONS IN [ ] ARE IN MILLIMETERS.

THRU-THE-BASE CHART THESE HOLES REQUIRED FOR USE CRBTMPWR005A00, 006A00, 007A00				
ACCESSORY NO.		THREADED CONDUIT SIZE	WIRE USE	REQ'D HOLE SIZES (MAX.)
005	W	1/2"	ACC.	7/8" [22.2]
	X	1/2"	24V	7/8" [22.2]
	Y	1 1/4"	POWER	1 1/2" [38.1]
006	W	1/2"	ACC.	7/8" [22.2]
	X	1/2"	24V	7/8" [22.2]
	Y	1 1/2"	POWER	2" [50.8]
007	W	1/2"	ACC.	7/8" [22.2]
	X	1/2"	24V	7/8" [22.2]
	Y	2"	POWER	2 1/2" [63.5]

FOR "THRU-THE-BASEPAN" FACTORY OPTION, FITTINGS FOR X & Y ARE PROVIDED AS SPECIFIED ON "006".

**Fig. 2 - Thru the Base Connections, Access and Position**

C10388

CRBTMPWR

## INSTALLATION

1. Turn off all electric power (and gas if applicable) to the unit and/or its future installation location, and follow appropriate lock-out/tag-out procedures.
2. Before installing the roof top unit on its curb or base, run as much wiring and piping as is more convenient to do prior to unit installation.
3. Install the unit on its curb or base per applicable instructions. Optionally, the thru-the-bottom service connection may be installed on the unit before the unit is installed onto the roof, in which case this step moves back to between steps 8 and 9.
4. Select the appropriate cover plate and fittings for your unit's requirements for gas and electricity.
5. Install the fittings on the cover plate together with their associated gaskets and seals on each side of their openings.

**NOTE:** The 007 kit's 2" conduit fitting will not fit thru the basepan hole if it is first installed on the hole's cover plate (the fitting halves can be cocked and angled thru the hole by themselves). The halves of the 2" fitting must be installed together into the cover plate after the plate is screwed in place on the basepan.

**NOTE:** If the conduit connections and wiring is not going to occur right away, tape or otherwise cover the fitting holes so moisture does not get into the building or conduit if it rains in the interim.

6. Remove the outdoor and control box access panels.
7. Remove the existing solid cover plate, gasket and screws.
8. Install the new one with a fresh gasket.

**NOTE:** Heat pump units have a factory installed thru-the-bottom connection available, consisting of a 1/2 in electrical bulkhead connector for control wiring and a 1 1/2 in electrical bulkhead connector for power wiring. This is shown in Fig. 3. Steps 9 - 12 apply to it as well.

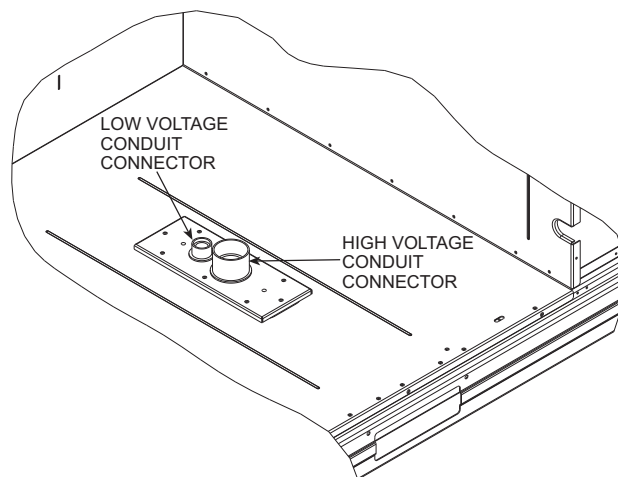

**Fig. 3 - Thru-Base Connection Fittings**

9. Connect field-supplied and field-installed conduit to the fittings on the bottom of the cover plate that you just screwed down to the base pan. If you have a 007 kit, you will need to finish installing the 2" bulkhead fitting now. Also connect gas piping if applicable.
10. Connect field-supplied and field-installed Sealite (or equivalent) conduit to the top of the cover fittings on the basepan. Connect the power conduit to the internal disconnect (if unit is so equipped) or to the external disconnect. For the external disconnect you can use two of the existing holes (conduit out and back in) or cut new one(s) as convenient. Remove one of the two knockouts located on the bottom left side of the unit control box and use this hole for the control conduit. Run separate power conduit to the convenience outlet if applicable.
11. Pull correctly rated high voltage and low voltage wire through appropriate conduits and connect per the unit wiring schematics and installation instructions. Use copper conductors only when splice connectors are used. When installing units, provide a disconnect per NEC. All field wiring must comply with NEC and local requirements. In Canada, electrical connections must be in accordance with CSA (Canadian Standards Association) C22.1 Canadian Electrical Code Part 1.
12. All units except 208/230V units are factory wired for the voltage shown on the nameplate. If the 208/230V unit is to be connected to a 208V power supply, the transformer must be rewired by moving the black wire from the 230V orange wire on the transformer and connecting it to the 200V red wire from the transformer. The end of the orange wire must then be insulated. Refer to unit label diagram for additional information.

13. For gas fired units, all piping and valves are field supplied. Unit is equipped for use with type of gas shown on nameplate. Size gas supply piping for 0.5inWg maximum pressure drop. Do not use supply pipe smaller than unit gas connection. Pipe the gas out thru the left knockout slot in the outdoor access panel, supporting it with the included gas pipe support bracket. Install a drip leg and shut-off valve, then rout the pipe back thru the right slot to the gas control valve as shown in Fig. 4. Refer to local building codes, or in the absence of local codes, to ANSI (American National Standards Institute) Z223.1 latest year and Addendum Z223.1A latest year entitled NFGC (National Fuel Gas Code). In Canada, installation must be in accordance with the CAN1.B149.1 and CAN1.B149.2 installation codes for gas appliances. For natural gas applications, gas pressure at unit gas connection must not be less than 4.0 inWg or greater than 13.0 inWg while unit is operating. For liquid propane and high heat applications, the gas pressure must not be less than 5.0 inWg or greater than 13.0 inWg at the unit connection.

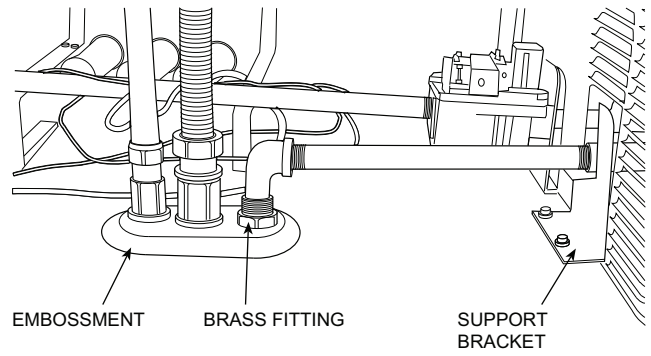

C10392

**Fig. 4 - Gas Line Piping, Typical**

14. Leak-check all gas piping and fittings.
15. After completing all other work, reinstall the outdoor and control box access panels.
16. Reverse lock-out/tag-out procedure and apply power and gas to the unit.

## MODELS AND SIZES

MODEL	SIZE
48LC	08-12
50LC	08-12
48TC	16
50TC	16
48HC	14
50HC	14
50TCQ	14
50HCQ	12
580J	16
558J	16
581J	14
551J	14
548J	14
549J	12
RGS	180
RAS	180
RGH	150
RAH	150
RHS	150
RHH	120

CRBTMPWR

