

Up to 16 SEER, Up to 12.5 EER, PACKAGE GAS / ELECTRIC UNIT, 2 to 5 TONS

208/230- 1 - 60, Single phase

208/230- 3 - 60, Three phase

REFRIGERATION CIRCUIT

- Environmentally balanced R- 410A refrigerant
- Copper tube/aluminum fin condenser and evaporator coils
- Tin- plated copper evaporator coil standard (single- phase only)
- Two stage scroll compressors standard on all models
- Two stage gas valve and two speed inducer motor on all models

EASY TO INSTALL AND SERVICE

- Installs easily on a rooftop or at ground level
- Easy three- panel accessibility for maintenance and installation
- Easily converts to down discharge applications
- Combination two- stage gas heating and electric cooling
- Low NOx units are designed for California installations and meet 40 ng/J NOx emissions. Can be installed in air quality management districts with a 40 ng/J NOx emissions requirement.

BUILT TO LAST

- Hail guard (3/8" spacing) wire grilles standard
 - Induced- draft combustion and venting
 - High efficiency ECM blower motor on all models
 - High efficiency two- speed inducer motor on single phase models
 - Pre- painted steel cabinet
 - Direct spark ignition
 - Stainless Steel tubular heat exchanger standard
 - Vertical condenser fan discharge
 - Full perimeter steel base rails
 - Crankcase heaters on select models
 - High and low pressure switches provide added reliability for the compressor
 - Cabinet air leakage of 2.0% or less at .5 in. W.C. when tested in accordance with ASHRAE standard 193
- Models with factory installed options are identified with letters in the 11th and 12th positions in the model number
- Single phase models with factory installed tin- plated copper evaporator main tubes PGR5 (GP),
 - 3- phase models with standard evaporator tubes PGR5 (GS)
 - Single and 3- phase models with factory installed option for low cabinet air leakage and tin- plated copper evaporator main tubes PGR5 (GC)

LIMITED WARRANTY*

- 1 Phase PGR5 Models
 - 5 year No Hassle Replacement™ limited warranty
 - 10 year parts limited warranty (including compressor and coils) and lifetime heat exchanger limited warranty with timely registration
 - 5 year parts limited warranty and 20 year heat exchanger limited warranty if not registered within 90 days of original installation.
- 3 Phase PGR5 Models
- 10 year heat exchanger limited warranty
 - 5 year compressor limited warranty
 - 1 year parts limited warranty

* See warranty certificate for complete details and restrictions



Use of the AHRI Certified TM Mark indicates a manufacturer's participation in the program. For verification of certification for individual products, go to www.ahrirectory.org.



As an Energy Star® Partner, International Comfort Products has determined that this product meets the ENERGY STAR® guidelines for energy efficiency.



UNIT PERFORMANCE DATA									
Model Number	COOLING			HEATING			Unit Dimensions Height x Width x Depth inches (mm)	Operating Weight lbs (kg)	
	Net Capacity BTU/h High Stage	SEER	EER	Input BTU/h High/Low	Efficiency AFUE %			1Ø	3Ø
					1Ø	3Ø			
PGR524040K**	23,000	15.0	12.0	40,000/26,000	81.0	-	44- 1/8 x 47 x 31- 7/16 (1121 x 1194 x 799)	342 (155)	-
PGR524060K**	23,000	15.0	12.0	60,000/39,000	81.0	-		376 (170)	376 (170)
PGR530040‡**	29,000	15.0	12.0	40,000/26,000	81.0	78.0			
PGR530060‡**	29,000	15.0	12.0	60,000/39,000	81.0	78.6	44- 3/4 x 47 x 42- 15/16 (1137 x 1194 x 1091)	463 (210)	463 (210)
PGR536060‡**	35,400	16.0	12.5	60,000/39,000	81.0	78.6			
PGR536090‡**	35,400	16.0	12.5	90,000/58,500	81.0	79.2			
PGR542060‡**	42,000	16.0	12.5	60,000/39,000	81.0	78.6	50- 3/4 x 47 x 42- 15/16 (1289 x 1194 x 1091)	481 (218)	481 (218)
PGR542090‡**	42,000	16.0	12.5	90,000/58,500	81.0	79.2			
PGR548090‡**	47,500	16.0	12.3	90,000/58,500	81.0	79.2			
PGR548115‡**	47,500	16.0	12.3	115,000/75,000	81.0	80.1	52- 3/4 x 47 x 42- 15/16 (1340 x 1194 x 1091)	509 (231)	509 (231)
PGR548130K**	47,500	16.0	12.3	127,000/84,500	81.0	-			
PGR548130H**	47,500	16.0	12.3	130,000/84,500	-	80.0			
PGR560090‡**	57,000	16.0	12.3	90,000/58,500	81.0	79.2			
PGR560115‡**	57,000	16.0	12.3	115,000/75,000	81.0	80.1			
PGR560130K**	57,000	16.0	12.3	127,000/84,500	81.0	-			
PGR560130H**	57,000	16.0	12.3	130,000/84,500	-	80.0			

‡ K = 208/230- 1 - 60, H = 208/230- 3 - 60

** GC = Low cabinet air leakage plus Tin- Plated Copper Evaporator Main Tubes, GP = Tin- Plated Evaporator Main Tubes (single phase), GS = Stainless Heat Exchanger (3- phase)

^ 0 = Standard, 1 = Low NOx

MODEL NOMENCLATURE										
	1	2	3,4	5,6	7,8,9	10	11,12	13	14	15
MODEL SERIES	P	G	R5	36	090	K	GS	0	C	1
TYPE P = Package A = Air Conditioner H = Heat Pump G = Gas/Electric										
TIER R5 = Mainline										
NOMINAL CLG CAPACITY 24 = 24,000 BTUH = 2 Tons 36 = 36,000 BTUH = 3 Tons 48 = 48,000 BTUH = 4 Tons 60 = 60,000 BTUH = 5 Tons										
NOMINAL HTG BTUH (input) 000 = no factory heat 040 = 40,000 BTU/hr 060 = 60,000 BTU/hr 090 = 90,000 BTU/hr 115 = 115,000 BTU/hr 130 = 127,000 or 130,000 BTU/hr										
VOLTAGE K = 208/230- 1- 60 H = 208/230- 3- 60										
FACTORY INSTALLED OPTIONS GC = Low Cabinet Air Leakage plus Tin Coated Copper Evap Main Tubes GP = Tin Coated Copper Evap Main Tubes plus Stainless Steel Heat Exchanger GS = Stainless Steel Heat Exchanger										
FEATURE CODE 0 = Standard 1 = Low NOx										
Sales Model Digit										
Engineering Digit										

For California Residents:

For installation in SCAQMD only: This furnace does not meet the SCAQMD Rule 1111 14 ng/J NOx emission limit, and thus is subject to a mitigation fee of up to \$450. This furnace is not eligible for the Clean Air Furnace Rebate Program: www.CleanAirFurnaceRebate.com

AHRI* CAPACITIES

Cooling Capacities and Efficiencies

Unit Size	Nominal Tons	Standard CFM (High / Low Stage)	Net Cooling Capacities - Btuh (High Stage)	EER @A**	SEER†
24	2	800 / 600	23000	12.0	15.0
30	2-1/2	1000 / 750	29000	12.0	15.0
36	3	1200 / 900	35400	12.5	16.0
42	3-1/2	1400 / 1050	42000	12.5	16.0
48	4	1600 / 1200	47500	12.3	16.0
60	5	1750 / 1200	57000	12.3	16.0

LEGEND

dB- Sound Levels (decibels)

db—Dry Bulb

SEER—Seasonal Energy Efficiency Ratio

wb—Wet Bulb

COP- Coefficient of Performance

* Air Conditioning, Heating & Refrigeration Institute.

**At "A" conditions- 80°F (26.7°C) indoor db/67°F (19.4°C) indoor wb & 95°F (35°C) outdoor db.

† Rated in accordance with U.S. Government DOE Department of Energy) test procedures and/or AHRI Standards 210/240.

Notes:

1. Ratings are net values, reflecting the effects of circulating fan heat.

Ratings are based on:

Cooling Standard: 80°F (26.7°C) db, 67°F wb (19.4°C) indoor entering- air temperature and 95°F db (35°C) outdoor entering- air temperature.

2. Before purchasing this appliance, read important energy cost and efficiency information available from AHRIdirectory.org.

Heating Capacities and Efficiencies 208/230 VAC Models Single Phase

UNIT SIZE	HEATING INPUT (BTUH) HIGH/LOW	OUTPUT CAPACITY (BTUH) HIGH / LOW	TEMPERATURE RISE RANGE HIGH °F (°C)	TEMPERATURE RISE RANGE LOW °F (°C)	AFUE (%)
24040 30040	40,000 / 26,000	33,000 / 22,000	25-55 (14-31)	25-55 (14-31)	81.0
24060 30060 36060 42060	60,000 / 39,000	49,000 / 32,000	25-55 (14-31)	25-55 (14-31)	81.0
36090 42090 48090 60090	90,000 / 58,500	74,000 / 48,000	35-65 (19-36)	35-65 (19-36)	81.0
48115 60115	115,000 / 75,000	94,000 / 62,000	30-60 (17-33)	30-60 (17-33)	81.0
48130 60130	127,000 / 84,500	104,000 / 70,000	35-65 (19-36)	35-65 (19-36)	81.0

LEGEND

AFUE - Annual Fuel Utilization Efficiency

NOTE: Before purchasing this appliance, read important energy cost and efficiency information available from AHRIdirectory.org.

208/230 VAC Models 3- Phase

UNIT SIZE	HEATING INPUT (BTUH) HIGH/LOW	OUTPUT CAPACITY (BTUH) HIGH / LOW	TEMPERATURE RISE RANGE HIGH °F (°C)	TEMPERATURE RISE RANGE LOW °F (°C)	AFUE (%)
24040 30040	40,000 / 26,000	32,000 / 21,000	20-50 (11-28)	15-45 (8-25)	78.0
24060 30060 36060 42060	60,000 / 39,000	49,000 / 31,000	25-55 (14-31)	25-55 (14-31)	78.6
36090 42090 48090 60090	90,000 / 58,500	74,000 / 47,000	35-65 (19-36)	35-65 (19-36)	79.2
48115 60115	115,000 / 75,000	93,000 / 61,000	30-60 (17-33)	30-60 (17-33)	80.1
48130 60130	130,000 / 84,500	103,000 / 68,000	35-65 (19-36)	35-65 (19-36)	80.0

LEGEND

AFUE - Annual Fuel Utilization Efficiency

NOTE: Before purchasing this appliance, read important energy cost and efficiency information available from AHRIdirectory.org.

A-Weighted Sound Power Level (dBA)

Unit Size	Sound Ratings (dBA)	TYPICAL OCTAVE BAND SPECTRUM (dBA without tone adjustment)						
		125	250	500	1000	2000	4000	8000
24	73	60.0	62.5	68.5	68.5	64.0	60.0	53.0
30	77	57.5	67.0	73.5	72.0	67.0	61.0	52.5
36	73	62.5	65.5	67.5	68.0	65.5	60.0	52.5
42	73	60.5	63.5	68.0	68.0	66.0	60.5	53.0
48	72	60.0	63.5	66.0	67.0	63.5	58.5	49.5
60	75	69.0	67.0	69.0	68.0	65.0	61.5	54.0

NOTE: Tested in accordance with AHRI Standard 270- 1995 (not listed in AHRI).

PHYSICAL DATA

UNIT SIZE	24040	24060	30040	30060	36060	36090	42060	42090
NOMINAL CAPACITY (ton)	2	2	2- 1/2	2- 1/2	3	3	3- 1/2	3- 1/2
SHIPPING WEIGHT** lb.	352	352	359	359	455	455	455	455
SHIPPING WEIGHT** (kg)	160	160	163	163	206	206	206	206
COMPRESSORS	2- Stage Scroll							
Quantity	1							
REFRIGERANT (R- 410A)								
Quantity lb.	6.4	6.4	8.3	8.3	8.1	8.1	8.7	8.7
Quantity (kg)	2.9	2.9	3.8	3.8	3.7	3.7	3.9	3.9
REFRIGERANT METERING DEVICE	TXV							
OUTDOOR COIL								
Rows...Fins/in.	1...21	1...21	2...21	2...21	2...21	2...21	2...21	2...21
Face Area (sq ft)	13.6	13.6	13.6	13.6	13.6	13.6	13.6	13.6
OUTDOOR FAN								
Nominal CFM	2500	2500	2700	2700	3000	3000	3000	3000
Diameter in.	24	24	24	24	26	26	26	26
Diameter (mm)	609.6	609.6	609.6	609.6	600.4	600.4	660.4	660.4
Motor Hp (Rpm)	1/10 (810)	1/10 (810)	1/5 (810)	1/5 (810)	1/5 (810)	1/5 (810)	1/5 (810)	1/5 (810)
INDOOR COIL								
Rows...Fins/in.	3...17	3...17	3...17	3...17	3...17	3...17	3...17	3...17
Face Area (sq ft)	3.7	3.7	3.7	3.7	4.7	4.7	4.7	4.7
INDOOR BLOWER								
Nominal Low Stage Cooling Airflow (Cfm)	600	600	750	750	900	900	1050	1050
Nominal High Stage Cooling Airflow (Cfm)	800	800	1000	1000	1200	1200	1400	1400
Size in.	10x10	10x10	10x10	10x10	11x10	11x10	11x10	11x10
Size (mm.)	254x254	254x254	254x254	254x254	279.4x254	279.4x254	279.4x254	279.4x254
Motor HP (RPM)	1/2 (1050)	1/2 (1050)	1/2 (1050)	1/2 (1050)	3/4 (1000)	3/4 (1000)	3/4 (1075)	3/4 (1075)
FURNACE SECTION*								
Burner Orifice No. (Qty...Drill Size)	2...44	3...44	2...44	3...44	3...44	3...38	3...44	3...38
Natural Gas (Factory Installed)	2...55	3...55	2...55	3...55	3...55	3...53	3...55	3...53
Propane Gas								
HIGH- PRESSURE SWITCH (psig) Cut- out Reset (Auto)	650 +/- 15 420 +/- 25							
LOSS- OF- CHARGE / LOW- PRESSURE SWITCH (psig) cut- out Reset (auto)	50 +/- 7 95 +/- 7							
DUCT RETURN- AIR FILTERS†‡								
Throwaway Size in. (mm)	20x20x1 508x508x25	20x24x1 508x610x25			24x30x1 610x762x25			

UNIT SIZE	48090	48115	48130	60090	60115	60130
NOMINAL CAPACITY (ton)	4	4	4	5	5	5
SHIPPING WEIGHT lb	500	500	500	520	520	520
SHIPPING WEIGHT kg	227	227	227	236	236	236
COMPRESSORS	2- Stage Scroll					
Quantity	1					
REFRIGERANT (R- 410A)						
Quantity lb	10.8	10.8	10.8	12.1	12.1	12.1
Quantity (kg.)	4.9	4.9	4.9	5.5	5.5	5.5
REFRIGERANT METERING DEVICE	TXV					
OUTDOOR COIL						
Rows...Fins/in.	2...21	2...21	2...21	2...21	2...21	2...21
Face Area (sq ft)	19.4	19.4	19.4	21.4	21.4	21.4
OUTDOOR FAN						
Nominal Cfm	3300	3300	3300	3600	3600	3600
Diameter in.	26	26	26	26	26	26
Diameter (mm)	660.4	660.4	660.4	660.4	660.4	660.4
Motor Hp (Rpm)	1/5 (810)	1/5 (810)	1/5 (810)	1/5 (810)	1/5 (810)	1/5 (810)
INDOOR COIL						
Rows...Fins/in.	3...17	3...17	3...17	3...17	3...17	3...17
Face Area (sq ft)	5.7	5.7	5.7	5.7	5.7	5.7
INDOOR BLOWER						
Nominal Low Stage Cooling Airflow (Cfm)	1200	1200	1200	1200	1200	1200
Nominal High Stage Cooling Airflow (Cfm)	1600	1600	1600	1750	1750	1750
Size in.	11x10	11x10	11x10	11x10	11x10	11x10
Size (mm)	279.4x254	279.4x254	279.4x254	279.4x254	279.4x254	279.4x254
Motor HP (RPM)	1.0 (1075)	1.0 (1075)	1.0 (1075)	1.0 (1075)	1.0 (1075)	1.0 (1075)
FURNACE SECTION*						
Burner Orifice No. (Qty...Drill Size)						
Natural Gas (Factory Installed)	3...38	3...33	3...31	3...38	3...33	3...31
Propane Gas	3...53	3...51	3...49	3...53	3...51	3...49
HIGH- PRESSURE SWITCH (psig) Cut- out Reset (Auto)	650 +/- 15 420 +/- 25					
LOSS- OF- CHARGE / LOW- PRESSURE SWITCH (psig) cut- out Reset (auto)	50 +/- 7 95 +/- 7					
DUCT RETURN- AIR FILTERS Thro- away†‡ in. (mm)	24x36x1 610x914x25					

*Based on altitude of 0 to 2000 ft (0- 610 m).

† Required filter sizes shown are based on the larger of the AHRI (Air Conditioning Heating and Refrigeration Institute) rated cooling airflow or the heating airflow velocity of 300 ft/minute for throwaway type. Air filter pressure drop for non- standard filters must not exceed 0.08 IN. W.C.

‡ If using accessory filter rack refer to the filter rack installation instructions for correct filter sizes and quantity.

OPTIONS AND ACCESSORIES

ITEM	DESCRIPTION	FACTORY INSTALLED OPTION	FIELD INSTALLED ACCESSORY
Coil Options	Base unit with tin plated indoor coil hairpins	X	
Compressor Start Kit	Compressor Start Kit assists compressor start- up by providing additional starting torque on sing phase units only.		X
Corporate Thermostats	Thermostats provide control for the system heating and cooling functions.		X
Crankcase Heater	Crankcase Heater provides anti- floodback protection for low- load cooling applications.		X*
Economizer	Vertical Economizer with Jade Honeywell W7220 Controller, Honeywell communicating actuator, and dry bulb sensor. (Contact MicroMetl Customer Service at 1- 800- 662- 4822 to order.)		X
	Horizontal Economizer with Jade Honeywell W7220 Controller, Honeywell communicating actuator, and dry bulb sensor. (Contact MicroMetl Customer Service at 1- 800- 662- 4822 to order.)		X
Filter Rack	Filter Rack features easy installation, serviceability, and high- filtering performance for vertical applications. Includes 1- in. filter.	X	X
Flat Roof Curb	14- in. (356 mm) Flat Roof Curb is available for roof mounted applications.		X
Flue Discharge Deflector	Directs flue gas exhaust 90 degrees upward from current discharge.		X
Heat Exchanger	Stainless Steel Heat Exchanger	X	
High Altitude Propane Conversion Kit	High Altitude Propane Conversion Kit is for use at 2001 to 6000 ft. (611- 1829 m) above sea level. Kit consists of propane gas orifices that compensate for gas heat operation at high altitude.		X
Low Ambient Kit	Low Ambient Kit (Motormaster II Control) allows the use of mechanical cooling down to outdoor temperatures as low as 0°F (- 18°C) when properly installed.		X
Manual Outside Air Damper	Manual Outside Air Damper includes hood and filter rack with adjustable damper blade for up to 25% outdoor air.		X
Natural to Propane Gas Conversion Kit	Natural to Propane Gas Conversion Kit allows for conversion from natural gas to propane gas (0- 2000 ft) (0- 610 m)		X
Propane to Natural Gas Conversion Kit	Propane to Natural Gas Conversion Kit allows for conversion from propane to natural gas for altitudes of 0- 2000 ft (0- 610 m)		X
Low Cabinet Air Leakage	Cabinet air leakage of 2.0% or less at .5 in. W.C. when tested in accordance with ASHRAE standard 193.	X	
Square- to- Round Duct Transition Kit	Square- to- Round Duct Transition Kit enable 24- 48 size units to be fitted to 14 in. (356 mm) round ductwork.		X

UNIT DIMENSIONS - 30 (THREE PHASE)

UNIT	ELECTRICAL CHARACTERISTICS	UNIT WT.		UNIT HEIGHT		CENTER OF GRAVITY	
		LB	KG	"-1"	"-1"	X	Z
PGRBS0(040/060)HGVA1	208/230-3-60	331	159.3	44-1/8	1121	22-13/16	579.4 15-5/16 388.9 16-5/8 422.3

UNIT	VOLTAGE	CORNER WEIGHT	
		LB/KG	"-4"
PGRBS0(040/060)HGVA1	208/230	89.7 40.7	79.0 35.8 85.8 38.9 96.5 43.8

NOTE: ALL TABLE DATA RELEVANT FOR ALL FACTORY INSTALLED OPTIONS EXCEPT ECONOMIZER

REQUIRED CLEARANCES TO COMBUSTIBLE MATL.

	INCHES (MM)
TOP OF UNIT	14 (355.6)
DUCT SIDE OF UNIT	2 (50.8)
SIDE OPPOSITE DUCTS	14 (355.6)
POWER ENTRY	12 (304.8)
FLUE PANEL	36 (914.4)

REC. REQUIRED CLEARANCES

	INCHES (MM)
BETWEEN UNITS, POWER ENTRY SIDE	42 (1066.8)
UNIT AND GROUNDED SURFACES, POWER ENTRY SIDE	36 (914.4)
UNIT AND BLOCK OR CONCRETE WALLS AND OTHER GROUNDED SURFACES, POWER ENTRY SIDE	42 (1066.8)

REQUIRED CLEARANCE FOR OPERATION AND SERVICING

	INCHES (MM)
EVAP. COIL ACCESS SIDE	36 (914.4)
POWER ENTRY SIDE	42 (1066.8)
EXCEPT FOR REC REQUIREMENTS	48 (1219.2)
UNIT TOP	36 (914.4)
DUCT SIDE OPPOSITE DUCTS	12 (304.8)
DUCT PANEL	36 (914.4)

*MINIMUM DISTANCES IF UNIT IS PLACED LESS THAN 12 (304.8) FROM WALL SYSTEM, THEN SYSTEM PERFORMANCE MAY BE COMPROMISED.

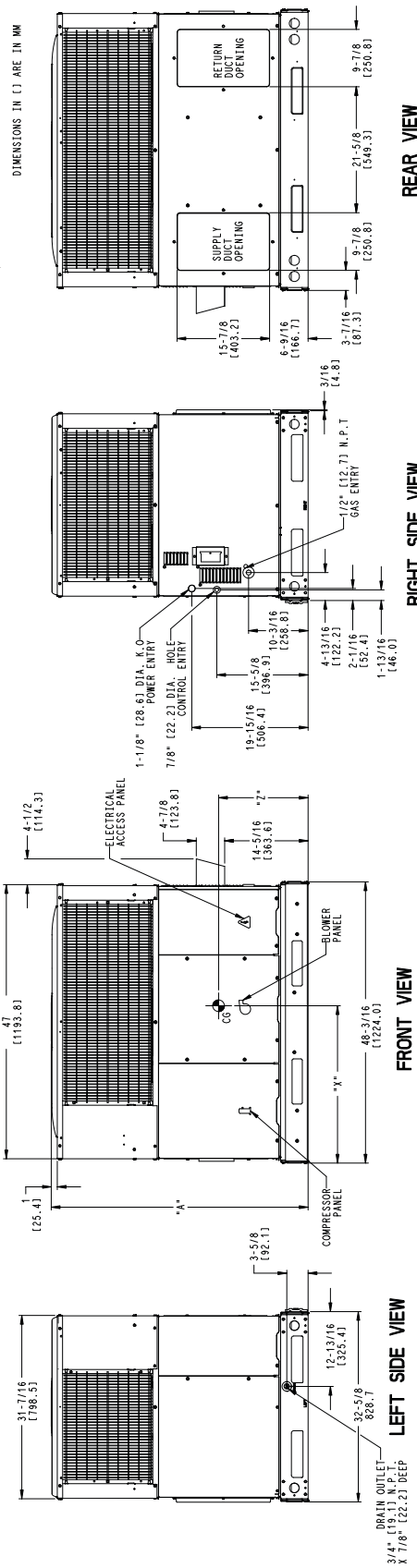

UNIT DIMENSIONS - 36-60 (THREE PHASE)

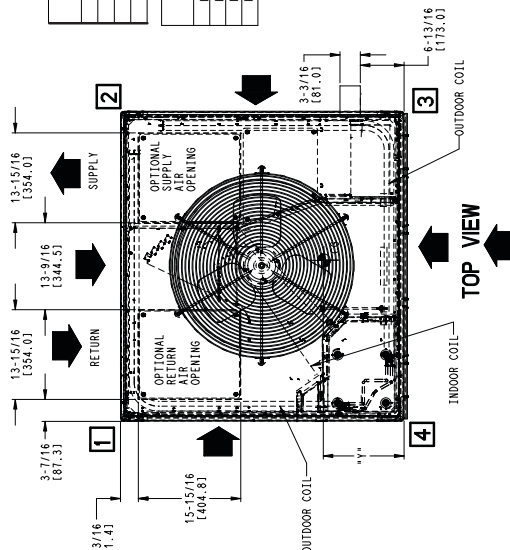

UNIT	ELECTRICAL CHARACTERISTICS		UNIT WT.		UNIT HEIGHT IN/AM		CENTER OF GRAVITY IN/AM					
	208/230-3-60	208/230-3-60	LB	KG	"A"	"X"	"Y"	"Z"				
PGR560(090/115/130)HG/A01	208/230-3-60	208/230-3-60	447	202.8	44-3/4	1137	22-13/16	579.4	18	457.2	17-1/8	435.0
PGR542(090/115/130)HG/A01	208/230-3-60	208/230-3-60	447	202.8	44-3/4	1137	22-13/16	579.4	18	457.2	17-1/8	435.0
PGR548(090/115/130)HG/A01	208/230-3-60	208/230-3-60	492	223.2	50-3/4	1289	22-13/16	579.4	18	457.2	17-3/8	441.3
PGR560(090/115/130)HG/A01	208/230-3-60	208/230-3-60	512	232.2	52-3/4	1340	22-13/16	579.4	18	457.2	17-5/8	447.7

UNIT	CORNER WEIGHT LB/KG	
	"1"	"4"
PGR560(090/115/130)HG/A01	121.2	54.4
PGR542(090/115/130)HG/A01	121.2	54.4
PGR548(090/115/130)HG/A01	139.2	63.4
PGR560(090/115/130)HG/A01	142.2	64.5

NOTE: ALL TABLE DATA RELEVANT FOR ALL FACTORY INSTALLED OPTIONS EXCEPT ECONOMIZER

- REQUIRED CLEARANCES TO COMBUSTIBLE UNIT**
- TOP OF UNIT.....14 [355.6]
 DUCT SIDE OF UNIT.....2 [50.8]
 SIDE OPPOSITE DUCTS.....14 [355.6]
 UNIT.....12 [304.8]
 FLUE PANEL.....36 [914.4]
- MIN. REQUIRED CLEARANCES**
- BETWEEN UNITS, POWER ENTRY SIDE.....42 [1066.8]
 UNIT AND UNGROUND SURFACES, POWER ENTRY SIDE.....36 [914.0]
 BETWEEN UNITS, GROUND SURFACES, POWER ENTRY SIDE.....42 [1066.8]
 GROUND SURFACES, POWER ENTRY SIDE.....42 [1066.8]
- REQUIRED CLEARANCE FOR OPERATION AND SERVICING**
- EVAP. COIL ACCESS SIDE.....36 [914.0]
 POWER ENTRY SIDE.....42 [1066.8]
 UNIT CLEARANCE FOR REC. REQUIREMENTS.....48 [1219.2]
 UNIT TOP FOR REC. REQUIREMENTS.....36 [914.0]
 SIDE OPPOSITE DUCTS.....12 [304.8]
 DUCT PANEL.....12 [304.8]
- *MINIMUM DISTANCES: IF UNIT IS PLACED LESS THAN 12 [304.8] FROM WALL SYSTEM, THEN SYSTEM PERFORMANCE MAY BE COMPROMISED.

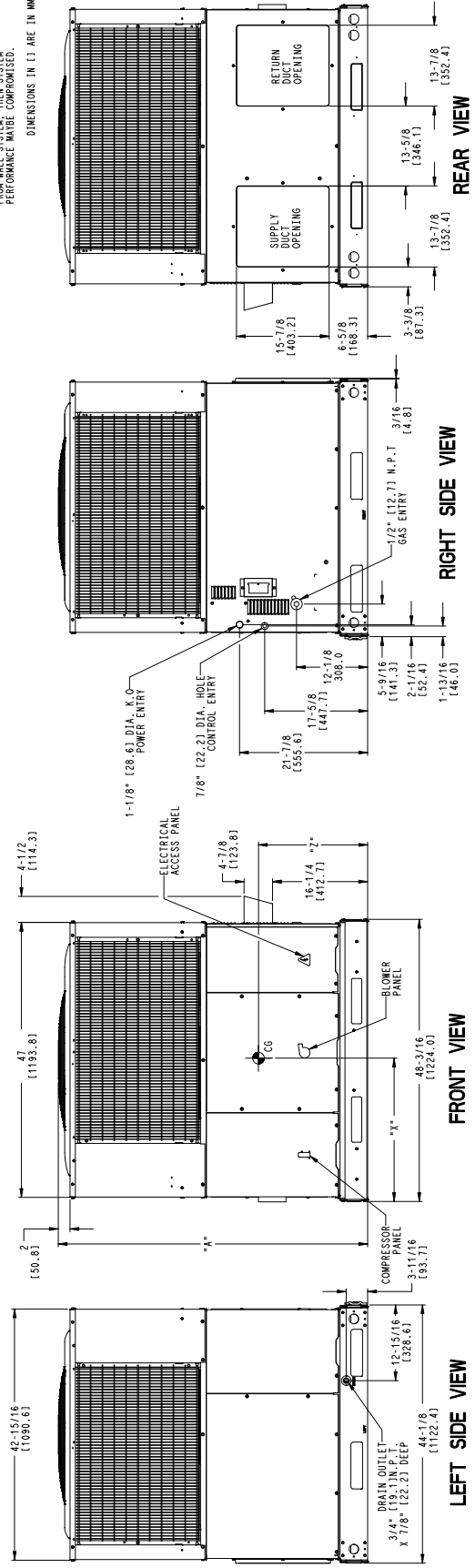

UNIT DIMENSIONS - 24-30 (SINGLE PHASE)

UNIT	ELECTRICAL CHARACTERISTICS	UNIT WT.		UNIT HEIGHT		CENTER OF GRAVITY					
		LB.	KG.	"A"	"X"	Y	Z				
FG8524(040/060)KGP(07)B1	208/230-1-60	344	156.1	44-1/8	1121	22-13/16	519.4	15-5/16	388.9	15-13/16	401.6
FG8530(040/060)KGP(07)B1	208/230-1-60	351	159.3	44-1/8	1121	22-13/16	519.4	15-5/16	388.9	16-5/8	422.3

UNIT	VOLTAGE		CORNER WEIGHT						
	"1"	"2"	LB/AG	"4"					
FG8524(040/060)KGP(07)B1	208/230	87.9	39.9	77.6	35.2	84.1	38.2	94.4	42.8
FG8530(040/060)KGP(07)B1	208/230	89.7	40.7	79.0	35.8	85.8	38.9	96.5	43.8

NOTE: ALL TABLE DATA RELEVANT FOR ALL FACTORY INSTALLED OPTIONS EXCEPT ECONOMIZER

REQUIRED CLEARANCES TO COMBUSTIBLE MATL.

	INCHES (MM)
TOP OF UNIT	4 (102.0)
TOP SIDE OF UNIT	2 (50.8)
SIDE OPPOSITE DUCTS	14 (355.6)
BOTTOM OF UNIT	12 (304.8)
FLUE PANEL	36 (914.4)

NEC REQUIRED CLEARANCES

	INCHES (MM)
BETWEEN UNITS, POWER ENTRY SIDE	42 (1066.8)
BETWEEN UNITS, POWER ENTRY SIDE, UNIT AND BLOCK OR CONCRETE WALLS AND OTHER GROUNDED SURFACES, POWER ENTRY SIDE	36 (914.4)
42 (1066.8)	

REQUIRED CLEARANCE FOR OPERATION AND SERVICING

	INCHES (MM)
EVAP. COIL ACCESS SIDE	36 (914.0)
POWER ENTRY SIDE	42 (1066.8)
UNITS FOR NEC REQUIREMENTS	42 (1066.8)
UNITS FOR NEC REQUIREMENTS	48 (1219.2)
SIDE OPPOSITE DUCTS	36 (914.0)
DUCT PANEL	12 (304.8)*

*MINIMUM DISTANCES: IF UNIT IS PLACED LESS THAN 12 (304.8) FROM WALL SYSTEM, THEN SYSTEM PERFORMANCE MAYBE COMPROMISED.

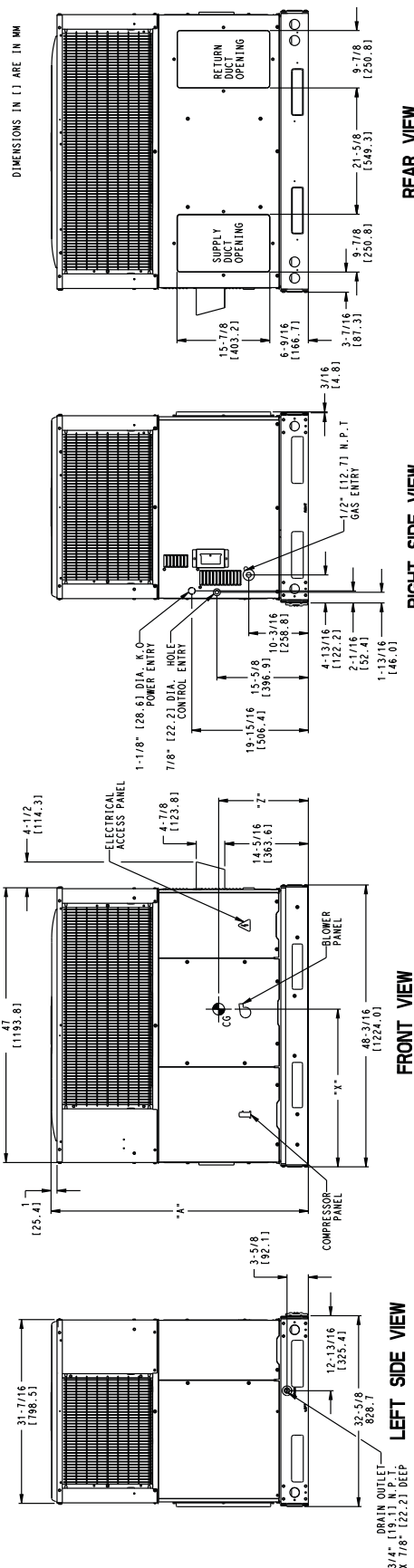

50CY502821
REV -

ACCESSORY DIMENSIONS

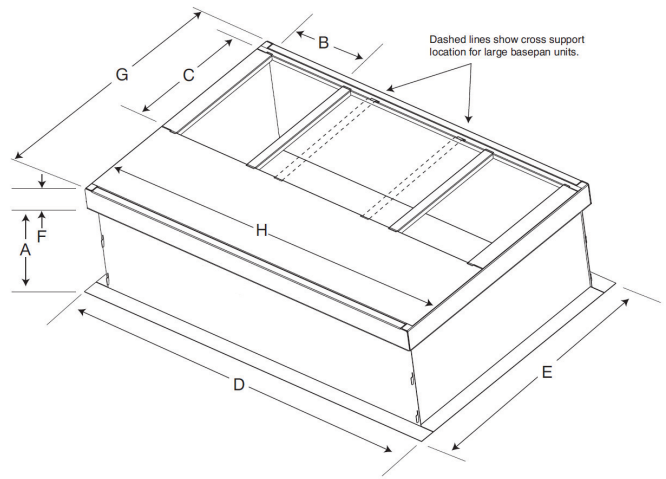
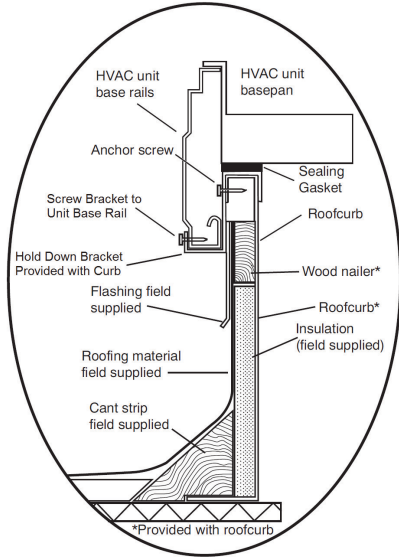

SMALL/COMMON CURB

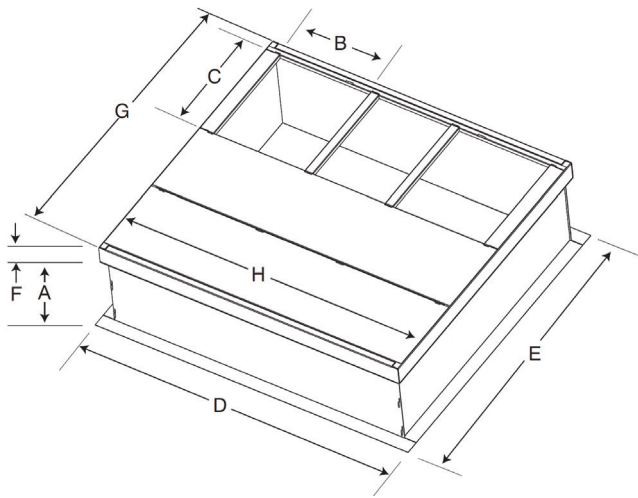

LARGE CURB

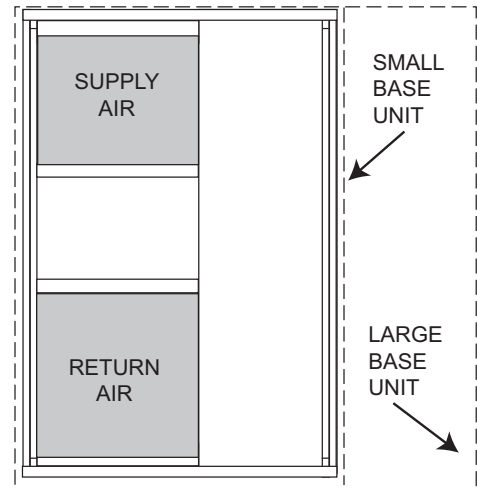

UNIT PLACEMENT ON COMMON CURB

SMALL OR LARGE BASE UNIT

A180216

UNIT SIZE	CATALOG NUMBER	A IN. (mm)	B (small / common base) IN. (mm)*	B (large base) IN. (mm)*	C IN. (mm)	D IN. (mm)	E IN. (mm)	F IN. (mm)	G IN. (mm)	H IN. (mm)
Small or Large	CPRFCURB011B00	14 (356)	10 (254)	14 (356)	16 (406)	47.8 (1214)	32.4 (822)	2.7 (69)	30.6 (778)	46.1 (1170)
Large	CPRFCURB013B00	14 (356)	14 (356)				43.9 (1116)			

* Part Number CPRFCURB011B00 can be used on both small and large basepan units. The cross supports must be located based on whether the unit is a small basepan or a large basepan.

NOTES:

1. Roof curb must be set up for unit being installed.
2. Seal strip must be applied, as required, to unit being installed.
3. Roof curb is made of 16- gauge steel.
4. Attach ductwork to curb (flanges of duct rest on curb).
5. Insulated panels: 1- in. (25.4 mm) thick fiberglass 1 lb. density.

SELECTION PROCEDURE (WITH EXAMPLE)

1. Determine cooling and heating requirements at design conditions:

Given:

Required Cooling Capacity (TC) 34,000 Btuh
Sensible Heat Capacity (SHC) 25,000 Btuh
Required Heating Capacity 60,000 Btuh
Condenser Entering Air Temperature . . 95°F (35°C)
Indoor- Air Temperature 80°F (26°C)edb 67°F (19°C)ewb
Evaporator Air Quantity 1200 CFM
External Static Pressure 0.100 IN. W.C.
Electrical Characteristics 208- 1- 60

2. Select unit based on required cooling capacity.

Enter Net Cooling Capacities table at condenser entering temperature of 95°F (35°C). Unit 036 at 1200 cfm and 67°F (19°C) ewb (entering wet bulb) will provide a total capacity of 34,200 Btuh and a SHC of 27,400 Btuh. Calculate SHC correction, if required, using Note 4 under Cooling Capacities tables.

3. Select heating capacity of unit to provide design condition requirement.

In the Heating Capacities and Efficiencies table, note that the unit 036090 (208/230 VAC) will provide 74,000 Btuh with an input of 90,000 Btuh in high stage and will provide 48,000 Btuh of heating in low stage.

4. Determine fan speed and power requirements at design conditions.

Before entering the air delivery tables, calculate the total static pressure required. From the given example, the Wet Coil Pressure Drop Table, and the Filter Pressure Drop Table:

External Static Pressure	0.100 IN. W.C
Filter	0.07 IN. W.C
Wet Coil Pressure Drop	<u>0.180</u> IN. W.C
Total Static Pressure	0.287 IN. W.C

Enter the table for Dry Coil Air Delivery—Horizontal and Downflow Discharge. At .287 IN. W.C. ESP, the closest speed to 1200 CFM is Med- Hi (orange wire), which delivers 1267 CFM at .3 in ESP.

5. Select unit that corresponds to power source available.

The Electrical Data Table shows that the unit is designed to operate at 208- 1- 60.

PERFORMANCE DATA

24 Low Cool

EVAPORATOR AIR		CONDENSER ENTERING AIR TEMPERATURES °F (°C)																		
		75 (23.9)			85 (29.4)			95 (35)			105 (40.6)			115 (46.1)			125 (51.7)			
		Capacity MBtuh		Total Syst KW	Capacity MBtuh		Total Syst KW	Capacity MBtuh		Total Syst KW	Capacity MBtuh		Total Syst KW	Capacity MBtuh		Total Syst KW	Capacity MBtuh		Total Syst KW	
CFM	EWB °F (°C)	Total	Sens	Total	Sens	Total	Sens	Total	Sens	Total	Sens	Total	Sens	Total	Sens	Total	Sens	Total	Sens	
		525	57(13.8)	17.82	17.82	16.44	16.44	1.24	15.06	15.06	1.41	13.67	13.67	1.60	12.27	12.27	1.81	10.86	10.86	2.04
62(16.6)	18.21		16.78	15.16	15.16	1.24	15.05	15.05	1.41	13.69	13.69	1.60	12.28	12.28	1.81	10.88	10.88	2.04	2.04	
63*(17.2)	18.58		13.61	12.24	12.24	1.23	15.39	10.90	1.41	13.80	9.59	1.60	12.20	8.32	1.82	10.62	7.10	2.05	2.05	
67(19.4)	19.95		14.13	10.4	18.24	12.71	1.21	16.54	11.34	1.39	14.83	10.00	1.58	13.13	8.69	1.80	11.44	7.44	2.03	2.03
72(22.2)	21.87		11.42	10.1	20.00	10.22	1.18	18.14	9.05	1.36	16.28	7.92	1.56	14.42	6.82	1.78	12.59	5.78	2.01	2.01
57(13.8)	18.60		18.60	17.14	17.14	1.24	15.68	15.68	1.42	14.21	14.21	1.61	12.73	12.73	1.82	11.25	11.25	2.05	2.05	
600	62(16.6)	18.65	18.61	17.17	17.17	1.24	15.71	15.71	1.42	14.23	14.23	1.61	12.75	12.75	1.82	11.27	11.27	2.05	2.05	
	63*(17.2)	18.96	14.57	10.8	17.31	13.11	1.24	15.67	11.69	1.42	14.03	10.31	1.61	12.39	8.97	1.83	10.77	7.67	2.06	2.06
	67(19.4)	20.34	15.15	10.5	18.58	13.66	1.22	16.82	12.20	1.40	15.06	10.77	1.60	13.31	9.39	1.81	11.59	8.05	2.04	2.04
	72(22.2)	22.29	12.08	10.2	20.35	10.81	1.19	18.43	9.59	1.37	16.52	8.40	1.57	14.61	7.26	1.79	12.73	6.17	2.02	2.02
	57(13.8)	19.26	19.26	17.73	17.73	1.25	16.20	16.20	1.42	14.66	14.66	1.62	13.11	13.11	1.83	11.57	11.57	2.06	2.06	
	62(16.6)	19.29	19.29	17.75	17.75	1.25	16.22	16.22	1.42	14.68	14.68	1.62	13.13	13.13	1.83	11.59	11.59	2.06	2.06	
675	63*(17.2)	19.25	15.50	10.9	17.56	13.97	1.25	15.88	12.47	1.43	14.21	11.01	1.63	12.53	9.59	1.84	10.89	8.21	2.07	2.07
	67(19.4)	20.64	16.16	10.6	18.83	14.58	1.23	17.03	13.03	1.41	15.24	11.53	1.61	13.45	10.06	1.82	11.70	8.65	2.05	2.05
	72(22.2)	22.59	12.71	10.3	20.61	11.39	1.20	18.64	10.12	1.39	16.69	8.88	1.58	14.74	7.68	1.80	12.83	6.55	2.03	2.03

24 High Cool

EVAPORATOR AIR		CONDENSER ENTERING AIR TEMPERATURES °F (°C)																		
		75 (23.9)			85 (29.4)			95 (35)			105 (40.6)			115 (46.1)			125 (51.7)			
		Capacity MBtuh		Total Syst KW	Capacity MBtuh		Total Syst KW	Capacity MBtuh		Total Syst KW	Capacity MBtuh		Total Syst KW	Capacity MBtuh		Total Syst KW	Capacity MBtuh		Total Syst KW	
CFM	EWB °F (°C)	Total	Sens	Total	Sens	Total	Sens	Total	Sens	Total	Sens	Total	Sens	Total	Sens	Total	Sens	Total	Sens	
		700	57(13.8)	23.89	23.89	22.22	22.22	1.70	20.54	20.54	1.87	18.86	18.86	2.05	17.17	17.17	2.26	15.50	15.50	2.48
62(16.6)	24.55		21.58	15.5	22.62	20.64	1.71	20.72	19.69	1.87	18.89	18.89	2.05	17.20	17.20	2.26	15.52	15.52	2.48	2.48
63*(17.2)	25.02		17.56	15.6	23.05	16.72	1.71	21.08	15.86	1.87	19.13	15.01	2.06	17.19	14.15	2.26	15.30	13.30	2.48	2.48
67(19.4)	26.85		18.20	15.7	24.72	17.34	1.73	22.61	16.48	1.89	20.50	15.61	2.07	18.42	14.75	2.27	16.39	13.89	2.49	2.49
72(22.2)	29.38		14.76	16.0	27.04	13.97	1.75	24.71	13.17	1.92	22.42	12.98	2.10	20.14	11.59	2.30	17.91	10.81	2.52	2.52
57(13.8)	24.94		24.94	23.16	23.16	1.73	21.38	21.38	1.90	19.59	19.59	2.08	17.81	17.81	2.28	16.04	16.04	2.51	2.51	
800	62(16.6)	25.14	23.30	15.8	23.20	23.20	1.73	21.41	21.41	1.90	19.62	19.62	2.08	17.83	17.83	2.28	16.06	16.06	2.51	2.51
	63*(17.2)	25.56	18.77	15.8	23.51	17.89	1.73	21.48	17.00	1.90	19.46	16.11	2.08	17.46	15.22	2.28	15.51	14.34	2.50	2.50
	67(19.4)	27.40	19.50	16.0	25.19	18.60	1.75	23.00	17.70	1.92	20.83	16.80	2.10	18.68	15.89	2.30	16.60	15.00	2.52	2.52
	72(22.2)	29.94	15.58	16.2	27.52	14.76	1.78	25.12	13.94	1.95	22.74	13.12	2.13	20.40	12.31	2.33	18.12	11.50	2.54	2.54
	57(13.8)	25.82	25.82	16.0	23.95	23.95	1.76	22.08	22.08	1.92	20.20	20.20	2.11	18.33	18.33	2.31	16.48	16.48	2.53	2.53
	62(16.6)	25.86	25.86	16.0	23.98	23.98	1.76	22.11	22.11	1.92	20.23	20.23	2.11	18.35	18.35	2.31	16.50	16.50	2.53	2.53
900	63*(17.2)	25.97	19.95	16.0	23.86	19.03	1.75	21.77	18.11	1.92	19.70	17.18	2.10	17.66	16.25	2.30	15.68	15.32	2.52	2.52
	67(19.4)	27.81	20.76	16.2	25.54	19.83	1.77	23.30	18.89	1.94	21.07	17.95	2.12	18.88	17.01	2.32	16.76	16.07	2.54	2.54
	72(22.2)	30.37	16.37	16.4	27.89	15.53	1.80	25.42	14.69	1.97	22.99	13.85	2.15	20.59	13.01	2.35	18.26	12.18	2.56	2.56

See Legend and Notes on Page 18.

PERFORMANCE DATA (CONT)

30 Low Cool EVAPORATOR AIR		CONDENSER ENTERING AIR TEMPERATURES °F (°C)																		
		75 (23.9)			85 (29.4)			95 (35)			105 (40.6)			115 (46.1)			125 (51.7)			
		Capacity MBtuh		Total Syst KW	Capacity MBtuh		Total Syst KW	Capacity MBtuh		Total Syst KW	Capacity MBtuh		Total Syst KW	Capacity MBtuh		Total Syst KW	Capacity MBtuh		Total Syst KW	
CFM	EWB °F (°C)	Total	Sens	Total	Sens	Total	Sens	Total	Sens	Total	Sens	Total	Sens	Total	Sens	Total	Sens	Total	Sens	
			57(13.8)	22.30	22.30	20.19	20.19	1.43	1.43	18.10	18.10	1.53	1.53	16.02	16.02	13.97	13.97	1.59	1.59	11.95
	62(16.6)	22.91	20.51	17.72	14.35	1.43	1.48	18.23	15.01	1.53	1.53	16.05	16.05	13.99	13.99	1.59	1.59	11.97	11.97	1.60
655	63*(17.2)	23.36	16.69	14.35	10.72	1.43	1.48	18.55	12.60	1.53	1.53	16.21	9.92	13.91	7.86	1.59	1.59	11.68	5.91	1.60
	67(19.4)	25.19	17.36	14.93	10.72	1.46	1.46	19.99	12.60	1.51	1.51	17.47	10.36	15.00	8.21	1.58	1.58	12.60	6.19	1.59
	72(22.2)	27.74	14.14	12.08	8.24	1.38	1.44	22.00	10.11	1.49	1.49	19.22	8.24	16.51	6.47	1.57	1.57	13.88	4.82	1.58
	57(13.8)	23.33	23.33	21.08	18.87	1.45	1.50	18.87	18.87	1.54	1.54	16.68	16.68	14.51	14.51	1.60	1.60	12.38	12.38	1.61
	62(16.6)	23.49	22.18	21.12	18.90	1.45	1.50	18.90	18.90	1.54	1.54	16.70	16.70	14.53	14.53	1.60	1.60	12.39	12.39	1.61
750	63*(17.2)	23.87	17.87	15.38	10.72	1.45	1.45	21.36	15.38	1.50	1.50	18.90	10.67	14.12	8.46	1.61	1.61	11.84	6.38	1.61
	67(19.4)	25.72	18.62	16.04	10.72	1.43	1.43	23.00	16.04	1.48	1.48	20.35	13.55	17.75	11.16	1.57	1.57	12.76	6.70	1.60
	72(22.2)	28.29	14.94	12.78	8.24	1.40	1.40	25.30	12.78	1.46	1.46	22.37	10.72	19.51	8.75	1.55	1.55	14.03	5.14	1.59
	57(13.8)	24.14	24.14	21.79	19.48	1.47	1.47	21.79	19.48	1.52	1.52	19.48	19.48	17.18	17.18	14.92	14.92	12.71	12.71	1.62
	62(16.6)	24.18	24.18	21.82	19.50	1.46	1.46	21.82	19.50	1.52	1.52	19.50	19.50	17.21	17.21	1.59	1.59	14.94	14.94	1.62
840	63*(17.2)	24.24	18.95	16.32	10.72	1.47	1.47	21.66	16.32	1.52	1.52	19.15	11.35	16.00	14.28	1.60	1.60	11.96	6.80	1.63
	67(19.4)	26.09	19.78	17.06	10.72	1.45	1.45	23.31	17.06	1.50	1.50	20.60	14.43	17.95	11.90	1.59	1.59	15.36	9.47	1.62
	72(22.2)	28.69	15.67	13.42	8.24	1.42	1.42	25.62	13.42	1.48	1.48	22.63	11.27	19.71	9.21	1.57	1.57	16.86	7.26	1.60

30 High Cool EVAPORATOR AIR		CONDENSER ENTERING AIR TEMPERATURES °F (°C)																		
		75 (23.9)			85 (29.4)			95 (35)			105 (40.6)			115 (46.1)			125 (51.7)			
		Capacity MBtuh		Total Syst KW	Capacity MBtuh		Total Syst KW	Capacity MBtuh		Total Syst KW	Capacity MBtuh		Total Syst KW	Capacity MBtuh		Total Syst KW	Capacity MBtuh		Total Syst KW	
CFM	EWB °F (°C)	Total	Sens	Total	Sens	Total	Sens	Total	Sens	Total	Sens	Total	Sens	Total	Sens	Total	Sens	Total	Sens	
			57(13.8)	30.54	30.54	28.11	28.11	1.97	1.97	25.68	25.68	2.35	2.35	23.24	23.24	20.78	20.78	2.83	2.83	18.33
	62(16.6)	31.60	26.39	24.96	21.16	1.98	1.98	26.06	23.52	2.35	2.35	23.34	23.16	20.81	20.81	2.83	2.83	18.36	18.36	3.12
875	63*(17.2)	32.20	21.56	20.29	17.75	1.98	1.98	26.51	19.02	2.36	2.36	23.69	17.75	20.88	16.46	2.83	2.83	18.12	15.18	3.11
	67(19.4)	34.66	22.38	21.07	19.77	2.01	2.19	28.49	19.77	2.38	2.38	25.45	18.47	22.42	17.16	2.85	2.85	19.45	15.86	3.13
	72(22.2)	38.04	18.28	17.09	15.91	2.02	2.22	31.23	15.91	2.42	2.42	27.87	14.73	24.55	13.55	2.89	2.89	21.31	12.39	3.16
	57(13.8)	31.92	31.92	29.32	26.74	2.01	2.19	26.74	26.74	2.39	2.39	24.16	24.16	21.55	21.55	2.87	2.87	18.97	18.97	3.15
	62(16.6)	32.39	28.44	26.89	23.52	2.01	2.19	26.78	26.78	2.39	2.39	24.19	24.19	21.58	21.58	2.87	2.87	18.99	18.99	3.15
1000	63*(17.2)	32.92	23.02	22.57	20.35	2.02	2.19	27.01	20.35	2.39	2.39	24.10	19.02	21.21	17.67	2.86	2.86	18.37	16.33	3.14
	67(19.4)	35.39	23.93	22.57	21.20	2.04	2.22	29.00	21.20	2.42	2.42	25.86	19.84	22.74	18.46	2.88	2.88	19.70	17.10	3.16
	72(22.2)	38.82	19.27	18.03	16.81	2.06	2.26	31.76	16.81	2.46	2.46	28.30	15.59	24.87	14.37	2.92	2.92	21.55	13.17	3.19
	57(13.8)	33.07	33.07	30.34	27.63	2.05	2.23	27.63	27.63	2.43	2.43	24.91	24.91	22.18	22.18	2.90	2.90	19.49	19.49	3.19
	62(16.6)	33.13	33.13	30.38	27.67	2.05	2.23	27.67	27.67	2.43	2.43	24.94	24.94	22.21	22.21	2.90	2.90	19.51	19.51	3.19
1125	63*(17.2)	33.47	24.42	23.02	21.64	2.05	2.23	27.40	21.64	2.42	2.42	24.41	20.24	21.46	18.84	2.89	2.89	18.57	17.42	3.17
	67(19.4)	35.96	25.44	24.00	22.58	2.08	2.25	29.39	22.58	2.45	2.45	26.17	21.16	22.98	19.72	2.91	2.91	19.90	18.28	3.19
	72(22.2)	39.41	20.21	18.94	17.68	2.12	2.29	32.16	17.68	2.49	2.49	28.60	16.42	25.11	15.17	2.95	2.95	21.72	13.93	3.22

See Legend and Notes on Page 18.

PERFORMANCE DATA (CONT)

36 Low Cool

EVAPORATOR AIR		CONDENSER ENTERING AIR TEMPERATURES °F (°C)																		
		75 (23.9)			85 (29.4)			95 (35)			105 (40.6)			115 (46.1)			125 (51.7)			
		Capacity MBtuh	Total Syst KW	Total Capacity MBtuh	Total Syst KW	Total Capacity MBtuh	Total Syst KW	Total Capacity MBtuh	Total Syst KW	Total Capacity MBtuh	Total Syst KW	Total Capacity MBtuh	Total Syst KW	Total Capacity MBtuh	Total Syst KW	Total Capacity MBtuh	Total Syst KW			
785	EWB °F (°C)	25.86	25.86	23.52	23.52	21.19	21.19	1.74	1.74	18.89	18.89	16.59	16.59	1.93	1.93	14.33	14.33	2.02	2.02	
		26.33	24.60	23.73	22.02	21.23	21.23	1.74	1.74	18.92	18.92	16.62	16.62	1.93	1.93	14.35	14.35	2.02	2.02	
		26.84	19.92	24.16	17.75	21.53	15.63	1.74	1.74	18.93	13.59	16.37	11.61	1.94	1.94	13.88	9.71	2.03	2.03	
		28.92	20.73	26.02	18.48	23.18	16.30	1.72	1.72	20.39	14.19	17.65	12.15	1.92	1.92	14.97	10.19	2.02	2.02	
		31.81	16.77	1.48	28.62	14.85	1.59	25.50	13.00	1.70	22.43	11.22	1.80	19.42	9.51	1.90	16.49	7.89	2.00	2.00
900	EWB °F (°C)	27.03	27.03	24.55	24.55	22.09	22.09	1.75	1.75	19.65	19.65	17.23	17.23	1.94	1.94	14.84	14.84	2.03	2.03	
		27.07	27.07	24.59	24.59	22.12	22.12	1.75	1.75	19.68	19.68	17.25	17.25	1.94	1.94	14.86	14.86	2.03	2.03	
		27.41	21.37	1.55	24.64	19.06	1.65	21.93	16.82	1.75	19.25	14.64	1.85	16.63	12.53	1.95	14.08	10.51	2.04	2.04
		29.51	22.28	1.53	26.52	19.89	1.63	23.59	17.58	1.74	20.72	15.32	1.84	17.90	13.15	1.94	15.16	11.05	2.03	2.03
		32.43	17.75	1.50	29.14	15.74	1.61	25.92	13.80	1.71	22.76	11.93	1.82	19.67	10.14	1.92	16.67	8.43	2.01	2.01
1010	EWB °F (°C)	27.98	27.98	25.37	25.37	22.80	22.80	1.76	1.76	20.25	20.25	17.72	17.72	1.95	1.95	15.24	15.24	2.04	2.04	
		28.02	28.02	25.41	25.41	22.83	22.83	1.76	1.76	20.28	20.28	17.75	17.75	1.95	1.95	15.25	15.25	2.04	2.04	
		27.84	22.71	1.56	24.99	20.28	1.67	22.22	17.92	1.77	19.49	15.62	1.87	16.82	13.38	1.96	14.28	14.28	2.05	2.05
		29.94	23.73	1.54	26.88	21.21	1.65	23.89	18.76	1.75	20.96	16.38	1.85	18.09	14.07	1.95	15.32	11.82	2.04	2.04
		32.87	18.66	1.51	29.50	16.57	1.62	26.21	14.55	1.73	22.99	12.60	1.83	19.84	10.73	1.93	16.79	8.94	2.02	2.02

36 High Cool

EVAPORATOR AIR		CONDENSER ENTERING AIR TEMPERATURES °F (°C)																		
		75 (23.9)			85 (29.4)			95 (35)			105 (40.6)			115 (46.1)			125 (51.7)			
		Capacity MBtuh	Total Syst KW	Total Capacity MBtuh	Total Syst KW	Total Capacity MBtuh	Total Syst KW	Total Capacity MBtuh	Total Syst KW	Total Capacity MBtuh	Total Syst KW	Total Capacity MBtuh	Total Syst KW	Total Capacity MBtuh	Total Syst KW	Total Capacity MBtuh	Total Syst KW			
1050	EWB °F (°C)	35.86	35.86	33.72	33.72	31.52	31.52	2.76	2.76	29.26	29.26	26.89	26.89	3.34	3.34	24.47	24.47	3.69	3.69	
		36.94	33.14	2.30	34.42	31.53	2.52	29.88	27.76	29.31	26.93	24.51	26.93	3.34	3.34	24.51	24.51	3.69	3.69	
		37.62	27.02	2.31	35.04	25.57	2.53	32.41	24.12	2.77	29.71	22.66	3.03	26.94	21.18	3.34	24.13	19.71	3.69	3.69
		40.43	28.03	2.34	37.63	26.55	2.56	34.79	25.07	2.80	31.86	23.58	3.07	28.87	22.07	3.37	25.86	20.58	3.71	3.71
		44.31	22.80	2.39	41.22	21.45	2.61	38.07	20.10	2.85	34.86	18.73	3.11	31.58	17.37	3.41	28.28	16.02	3.75	3.75
1200	EWB °F (°C)	37.44	37.44	35.15	35.15	32.81	32.81	2.80	2.80	30.39	30.39	27.88	27.88	3.38	3.38	25.31	25.31	3.73	3.73	
		37.84	35.72	2.34	35.28	35.09	2.56	32.85	32.85	2.80	30.43	30.43	3.07	27.92	27.92	3.38	25.34	25.34	3.73	3.73
		38.44	28.86	2.34	35.75	27.35	2.56	33.01	25.83	2.80	30.22	24.30	3.07	27.35	22.75	3.37	24.48	21.21	3.71	3.71
		41.27	30.00	2.38	38.37	28.45	2.59	35.40	26.90	2.83	32.38	25.34	3.10	29.29	23.77	3.40	26.20	22.20	3.74	3.74
		45.20	24.05	2.43	41.98	22.65	2.64	38.71	21.25	2.88	35.39	19.85	3.15	32.00	18.44	3.45	28.62	17.05	3.79	3.79
1350	EWB °F (°C)	38.77	38.77	36.36	36.36	33.88	33.88	2.84	2.84	31.33	31.33	28.69	28.69	3.42	3.42	26.00	26.00	3.76	3.76	
		38.82	38.82	36.40	36.40	33.92	33.92	2.84	2.84	31.37	31.37	28.72	28.72	3.42	3.42	26.03	26.03	3.76	3.76	
		39.08	30.63	2.38	36.30	29.05	2.59	33.49	27.48	2.83	30.61	25.88	3.10	27.68	24.26	3.40	24.75	22.63	3.74	3.74
		41.92	31.90	2.41	38.92	30.29	2.63	35.87	28.67	2.86	32.77	27.04	3.13	29.62	25.40	3.43	26.47	23.74	3.77	3.77
		45.86	25.24	2.46	42.55	23.81	2.68	39.20	22.37	2.92	35.78	20.92	3.18	32.32	19.48	3.48	28.86	18.05	3.81	3.81

See Legend and Notes on Page 18.

PERFORMANCE DATA (CONT)

42 Low Cool EVAPORATOR AIR		CONDENSER ENTERING AIR TEMPERATURES °F (°C)																	
		75 (23.9)			85 (29.4)			95 (35)			105 (40.6)			115 (46.1)			125 (51.7)		
		Capacity MBtuh	Total Syst KW	Total Sens	Capacity MBtuh	Total Syst KW	Total Sens	Capacity MBtuh	Total Syst KW	Total Sens	Capacity MBtuh	Total Syst KW	Total Sens	Capacity MBtuh	Total Syst KW	Total Sens	Capacity MBtuh	Total Syst KW	Total Sens
915	57(13.8)	30.96	30.96	28.67	28.67	1.98	26.33	26.33	2.01	23.93	23.93	2.04	21.48	21.48	2.05	19.01	19.01	2.03	
	62(16.6)	31.67	29.10	26.30	1.97	26.44	26.27	2.01	23.97	23.97	2.04	21.51	21.51	2.05	19.03	19.03	2.03	2.03	
	63*(17.2)	32.30	29.63	21.25	1.97	26.89	18.92	2.01	24.12	16.63	2.04	21.31	14.41	2.05	18.51	12.28	2.04	2.04	
	67(19.4)	34.88	24.60	31.98	22.15	1.94	29.02	19.73	1.98	26.03	17.38	2.01	23.01	15.09	2.03	20.00	12.89	2.02	2.02
	72(22.2)	38.48	20.01	35.25	17.89	1.91	31.99	15.82	1.95	28.70	13.81	1.98	25.38	11.87	1.99	22.08	10.03	1.98	1.98
1050	57(13.8)	32.40	32.40	29.96	29.96	2.00	27.47	27.47	2.03	24.92	24.92	2.05	22.32	22.32	2.06	19.70	19.70	2.04	2.04
	62(16.6)	32.52	32.36	30.01	30.01	1.99	27.51	27.51	2.03	24.96	24.96	2.05	22.35	22.35	2.06	19.73	19.73	2.04	2.04
	63*(17.2)	33.02	25.34	30.24	22.82	1.99	27.41	20.34	2.03	24.54	17.91	2.06	21.65	15.55	2.07	18.77	13.28	2.06	2.06
	67(19.4)	35.63	26.44	32.61	23.83	1.97	29.55	21.26	2.01	26.46	18.75	2.03	23.35	16.31	2.04	20.26	13.96	2.03	2.03
	72(22.2)	39.26	21.17	35.92	18.95	1.93	32.54	16.78	1.97	29.14	14.67	2.00	25.72	12.64	2.01	22.33	10.70	1.99	1.99
1180	57(13.8)	33.57	33.57	31.00	31.00	2.01	28.38	28.38	2.05	25.70	25.70	2.07	22.99	22.99	2.07	20.25	20.25	2.05	2.05
	62(16.6)	33.62	33.62	31.04	31.04	2.01	28.42	28.42	2.05	25.74	25.74	2.07	23.02	23.02	2.07	20.27	20.27	2.05	2.05
	63*(17.2)	33.55	26.93	30.68	24.28	2.02	27.77	21.66	2.05	24.85	19.10	2.08	21.90	16.60	2.09	18.99	18.84	2.07	2.07
	67(19.4)	36.17	28.15	33.07	25.40	1.99	29.92	22.69	2.03	26.76	20.04	2.05	23.60	17.46	2.06	20.46	14.94	2.05	2.05
	72(22.2)	39.84	22.25	36.39	19.94	1.96	32.92	17.68	1.99	29.44	15.49	2.02	25.95	13.37	2.02	22.49	11.34	2.01	2.01

42 High Cool EVAPORATOR AIR		CONDENSER ENTERING AIR TEMPERATURES °F (°C)																	
		75 (23.9)			85 (29.4)			95 (35)			105 (40.6)			115 (46.1)			125 (51.7)		
		Capacity MBtuh	Total Syst KW	Total Sens	Capacity MBtuh	Total Syst KW	Total Sens	Capacity MBtuh	Total Syst KW	Total Sens	Capacity MBtuh	Total Syst KW	Total Sens	Capacity MBtuh	Total Syst KW	Total Sens	Capacity MBtuh	Total Syst KW	Total Sens
1225	57(13.8)	44.10	44.10	40.87	40.87	2.95	37.59	37.59	3.27	34.28	34.28	3.63	30.95	30.95	4.03	27.68	27.68	4.47	4.47
	62(16.6)	45.47	38.57	36.75	2.96	38.02	34.87	3.28	34.34	34.34	3.63	31.00	31.00	4.03	27.72	27.72	4.47	4.47	
	63*(17.2)	46.30	31.46	29.82	2.97	38.64	28.16	3.28	34.81	26.49	3.64	31.02	24.81	4.03	27.34	23.17	4.46	4.46	
	67(19.4)	49.63	32.58	27.1	45.48	30.90	3.00	41.33	29.20	3.32	37.21	27.50	3.67	33.12	25.80	4.06	29.18	24.14	4.49
	72(22.2)	54.17	26.44	27.5	49.61	24.90	3.04	45.06	23.34	3.36	40.53	21.79	3.72	36.05	20.23	4.11	31.74	18.73	4.54
1400	57(13.8)	45.98	45.98	42.52	42.52	3.01	39.03	39.03	3.33	35.52	35.52	3.69	32.01	32.01	4.08	28.56	28.56	4.52	4.52
	62(16.6)	46.52	41.52	42.71	42.37	3.01	39.08	39.08	3.33	35.57	35.57	3.69	32.04	32.04	4.08	28.59	28.59	4.52	4.52
	63*(17.2)	47.25	33.56	43.28	31.84	3.01	39.30	30.11	3.33	35.35	28.36	3.68	31.44	26.61	4.07	27.67	24.89	4.50	4.50
	67(19.4)	50.58	34.83	27.6	46.29	33.07	3.04	42.00	31.30	3.36	37.75	29.52	3.72	33.55	27.75	4.11	29.50	26.00	4.54
	72(22.2)	55.17	27.86	27.9	50.45	26.89	3.05	45.74	24.65	3.41	41.08	23.05	3.76	36.47	21.45	4.16	32.06	19.90	4.59
1575	57(13.8)	47.54	47.54	43.89	43.89	3.05	40.22	40.22	3.38	36.54	36.54	3.74	32.86	32.86	4.13	29.26	29.26	4.57	4.57
	62(16.6)	47.60	47.60	43.95	43.95	3.05	40.27	40.27	3.38	36.59	36.59	3.74	32.90	32.90	4.14	29.29	29.29	4.57	4.57
	63*(17.2)	47.97	35.58	43.88	33.79	3.05	39.80	31.99	3.37	35.76	30.17	3.72	31.76	28.34	4.12	27.94	26.51	4.55	4.55
	67(19.4)	51.31	37.00	46.89	35.17	3.08	42.50	33.33	3.40	38.15	31.48	3.76	33.86	29.62	4.15	29.75	27.77	4.58	4.58
	72(22.2)	55.92	29.22	28.4	51.07	27.57	3.12	46.25	25.93	3.45	41.47	24.28	3.81	36.77	22.64	4.20	32.27	21.05	4.63

See Legend and Notes on Page 18.

PERFORMANCE DATA (CONT)

48 Low Cool

EVAPORATOR AIR		CONDENSER ENTERING AIR TEMPERATURES °F (°C)																	
		75 (23.9)			85 (29.4)			95 (35)			105 (40.6)			115 (46.1)			125 (51.7)		
		CFM	EWB °F (°C)	Capacity MBtuh	Total Syst KW	Capacity MBtuh	Total Syst KW	Capacity MBtuh	Total Syst KW	Capacity MBtuh	Total Syst KW	Capacity MBtuh	Total Syst KW	Capacity MBtuh	Total Syst KW	Capacity MBtuh	Total Syst KW	Capacity MBtuh	Total Syst KW
1050	57(13.8)	35.18	35.18	2.15	32.65	32.65	2.21	30.08	30.08	2.26	27.45	27.45	2.29	24.76	24.76	2.29	22.01	22.01	2.26
	62(16.6)	35.89	33.38	2.14	32.99	30.42	2.21	30.13	30.13	2.26	27.49	27.49	2.29	24.80	24.80	2.29	22.04	22.04	2.25
	63*(17.2)	36.62	27.06	2.14	33.64	24.54	2.21	30.61	22.07	2.26	27.55	19.66	2.29	24.45	17.30	2.29	21.33	15.03	2.26
	67(19.4)	39.58	28.19	2.11	36.35	25.60	2.19	33.07	23.05	2.24	29.78	20.56	2.28	26.42	18.13	2.28	23.06	15.78	2.25
	72(22.2)	43.68	22.88	2.08	40.10	20.63	2.16	36.50	18.44	2.22	32.85	16.30	2.26	29.17	14.23	2.26	25.49	12.25	2.24
1200	57(13.8)	36.76	36.76	2.18	34.07	34.07	2.25	31.32	31.32	2.29	28.53	28.53	2.32	25.68	25.68	2.32	22.77	22.77	2.28
	62(16.6)	36.82	36.82	2.18	34.12	34.12	2.25	31.37	31.37	2.29	28.58	28.58	2.32	25.71	25.71	2.32	22.80	22.80	2.28
	63*(17.2)	37.37	28.96	2.18	34.28	26.30	2.25	31.15	23.69	2.30	27.99	21.13	2.32	24.79	18.64	2.32	21.59	16.21	2.29
	67(19.4)	40.36	30.24	2.15	37.01	27.49	2.23	33.63	24.79	2.28	30.21	22.14	2.31	26.77	19.57	2.31	23.32	17.07	2.28
	72(22.2)	44.51	24.17	2.12	40.80	21.82	2.20	37.07	19.52	2.26	33.30	17.29	2.29	29.52	15.13	2.29	25.74	13.06	2.26
1310	57(13.8)	37.76	37.76	2.21	34.95	34.95	2.27	32.10	32.10	2.32	29.20	29.20	2.34	26.23	26.23	2.34	23.23	23.23	2.30
	62(16.6)	37.81	37.81	2.21	35.00	35.00	2.27	32.15	32.15	2.32	29.24	29.24	2.34	26.27	26.27	2.34	23.26	23.26	2.30
	63*(17.2)	37.81	30.32	2.21	34.64	27.55	2.28	31.45	24.84	2.32	28.23	22.18	2.35	24.98	19.58	2.34	21.76	21.62	2.31
	67(19.4)	40.80	31.70	2.19	37.39	28.84	2.26	33.93	26.03	2.31	30.46	23.28	2.33	26.96	20.59	2.33	23.47	17.97	2.29
	72(22.2)	44.98	25.09	2.15	41.19	22.67	2.23	37.37	20.30	2.28	33.55	18.00	2.31	29.70	15.77	2.32	25.85	13.64	2.28

48 High Cool

EVAPORATOR AIR		CONDENSER ENTERING AIR TEMPERATURES °F (°C)																	
		75 (23.9)			85 (29.4)			95 (35)			105 (40.6)			115 (46.1)			125 (51.7)		
		CFM	EWB	Capacity MBtuh	Total Syst KW	Capacity MBtuh	Total Syst KW	Capacity MBtuh	Total Syst KW	Capacity MBtuh	Total Syst KW	Capacity MBtuh	Total Syst KW	Capacity MBtuh	Total Syst KW	Capacity MBtuh	Total Syst KW	Capacity MBtuh	Total Syst KW
1400	57(13.8)	48.89	48.89	3.11	45.66	45.66	3.41	42.38	42.38	3.75	39.05	39.05	4.13	35.68	35.68	4.55	32.30	32.30	4.99
	62(16.6)	50.28	43.47	3.12	46.51	41.71	3.42	42.75	39.90	3.76	39.11	39.11	4.13	35.73	35.73	4.55	32.34	32.34	4.99
	63*(17.2)	51.23	35.39	3.13	47.37	33.80	3.43	43.48	32.17	3.77	39.57	30.53	4.14	35.65	28.86	4.54	31.78	27.20	4.98
	67(19.4)	55.12	36.75	3.16	50.93	35.12	3.46	46.72	33.47	3.80	42.50	31.80	4.17	38.27	30.11	4.58	34.10	28.42	5.02
	72(22.2)	60.49	29.87	3.21	55.87	28.34	3.51	51.22	26.80	3.84	46.58	25.25	4.22	41.93	23.68	4.62	37.37	22.12	5.06
1600	57(13.8)	51.01	51.01	3.18	47.56	47.56	3.48	44.07	44.07	3.83	40.53	40.53	4.20	36.95	36.95	4.62	33.37	33.37	5.06
	62(16.6)	51.47	46.83	3.18	47.65	47.65	3.49	44.13	44.13	3.83	40.59	40.59	4.20	37.00	37.00	4.62	33.41	33.41	5.06
	63*(17.2)	52.30	37.79	3.19	48.28	36.13	3.49	44.24	34.44	3.83	40.20	32.73	4.20	36.15	30.99	4.60	32.18	29.26	5.04
	67(19.4)	56.21	39.32	3.23	51.86	37.62	3.53	47.50	35.90	3.86	43.13	34.16	4.23	38.77	32.40	4.64	34.50	30.65	5.07
	72(22.2)	61.65	31.49	3.27	56.85	29.91	3.57	52.04	28.32	3.91	47.24	26.72	4.28	42.45	25.11	4.68	37.76	23.52	5.11
1750	57(13.8)	52.37	52.37	3.23	48.78	48.78	3.54	45.15	45.15	3.88	41.47	41.47	4.25	37.75	37.75	4.68	34.04	34.04	5.11
	62(16.6)	52.45	52.45	3.23	48.85	48.85	3.54	45.21	45.21	3.88	41.52	41.52	4.26	37.79	37.79	4.66	34.08	34.08	5.11
	63*(17.2)	52.92	39.53	3.24	48.81	37.82	3.54	44.68	36.08	3.87	40.56	34.32	4.24	36.44	32.53	4.65	32.42	30.72	5.08
	67(19.4)	56.86	41.19	3.27	52.41	39.44	3.57	47.95	37.67	3.91	43.50	35.88	4.28	39.06	34.07	4.68	34.73	32.25	5.12
	72(22.2)	62.33	32.67	3.32	57.41	31.06	3.62	52.50	29.43	3.95	47.61	27.80	4.32	42.73	26.16	4.72	37.97	24.55	5.15

See Legend and Notes on Page 18.

PERFORMANCE DATA (CONT)

60 Low Cool EVAPORATOR AIR		CONDENSER ENTERING AIR TEMPERATURES °F (°C)																	
		75 (23.9)			85 (29.4)			95 (35)			105 (40.6)			115 (46.1)			125 (51.7)		
		Capacity MBtuh	Total Syst KW	Capacity MBtuh	Total Syst KW	Capacity MBtuh	Total Syst KW	Capacity MBtuh	Total Syst KW	Capacity MBtuh	Total Syst KW	Capacity MBtuh	Total Syst KW	Capacity MBtuh	Total Syst KW	Capacity MBtuh	Total Syst KW		
CFM	EWB °F (°C)	Total	Sens	Total	Sens	Total	Sens	Total	Sens	Total	Sens	Total	Sens	Total	Sens	Total	Sens		
1200	57(13.8)	42.50	42.50	41.54	2.61	41.54	41.54	2.64	40.36	40.36	38.87	38.87	2.59	37.03	37.03	2.49	34.82	34.82	
	62(16.6)	43.53	40.01	38.49	2.61	42.15	38.49	2.64	40.55	40.24	38.94	38.94	2.59	37.09	37.09	2.49	34.87	34.87	
	63*(17.2)	44.37	32.51	31.12	2.63	42.92	31.12	2.63	41.20	29.70	28.21	28.21	2.59	36.69	26.66	2.49	33.85	29.05	
	67(19.4)	47.96	33.87	32.46	2.59	46.38	32.46	2.62	44.50	31.00	29.49	29.49	2.58	39.65	27.93	2.49	36.60	26.30	
	72(22.2)	52.94	27.58	26.23	2.56	51.15	26.23	2.60	49.07	24.86	24.63	23.45	2.57	43.75	21.98	2.48	40.44	20.47	
	57(13.8)	44.36	44.36	43.29	2.67	43.29	43.29	2.69	41.98	41.98	2.68	40.36	40.36	2.63	38.36	38.36	2.53	35.98	35.98
1370	62(16.6)	44.59	44.18	43.36	2.67	43.36	43.36	2.69	42.05	42.05	2.68	40.42	40.42	2.63	38.42	38.42	2.53	36.03	36.03
	63*(17.2)	45.25	34.73	33.28	2.67	43.69	33.28	2.69	41.88	31.80	30.26	2.63	37.17	28.64	2.53	34.23	26.95		
	67(19.4)	48.88	36.25	34.77	2.65	47.18	34.77	2.68	45.19	33.26	31.70	2.62	42.87	30.07	2.53	36.99	28.37		
	72(22.2)	53.90	29.08	27.69	2.62	52.00	27.69	2.65	49.80	26.28	24.83	2.61	44.23	23.32	2.52	40.79	21.77		
	57(13.8)	45.96	45.96	44.78	2.73	44.78	44.78	2.75	43.35	43.35	2.73	41.59	41.59	2.67	39.46	39.46	2.57	36.92	36.92
	62(16.6)	46.03	46.03	44.84	2.73	44.84	44.84	2.75	43.41	43.41	2.73	41.65	41.65	2.67	39.51	39.51	2.57	36.97	36.97
1545	63*(17.2)	45.92	36.92	35.42	2.73	44.29	35.42	2.75	42.38	33.88	32.27	2.68	37.53	30.58	2.57	34.57	34.35		
	67(19.4)	49.57	38.62	37.08	2.71	47.78	37.08	2.73	45.71	35.51	33.88	2.67	40.48	32.18	2.57	37.28	30.36		
	72(22.2)	54.62	30.56	29.14	2.71	50.31	29.14	2.71	47.64	26.20	26.20	2.66	44.54	24.66	2.56	40.98	23.08		
	57(13.8)	48.88	48.88	47.18	2.65	47.18	47.18	2.68	45.19	33.26	31.70	2.62	42.87	30.07	2.53	36.99	28.37		
	62(16.6)	49.85	49.85	48.15	2.65	48.15	48.15	2.68	46.16	34.23	32.67	2.61	43.88	31.12	2.52	38.42	30.07		
	67(19.4)	53.90	45.96	44.78	2.73	44.78	44.78	2.75	43.35	43.35	2.73	41.59	41.59	2.67	39.46	39.46	2.57	36.92	36.92
60 High Cool EVAPORATOR AIR	57(13.8)	58.66	58.66	55.57	3.81	55.57	55.57	4.17	52.33	52.33	48.92	48.92	5.04	45.32	45.32	5.57	41.58	41.58	
	62(16.6)	59.85	53.13	51.25	3.82	56.20	51.25	4.17	52.51	52.25	48.99	48.99	5.05	45.37	45.37	5.57	41.63	41.63	
	63*(17.2)	60.83	43.11	41.43	3.82	57.05	41.43	4.18	53.16	39.70	37.91	37.91	5.04	44.88	36.06	5.56	40.58	34.17	
	67(19.4)	65.32	44.77	43.05	3.86	61.22	43.05	4.22	57.00	41.30	39.48	39.48	5.10	48.03	37.60	5.62	43.40	35.70	
	72(22.2)	71.52	36.12	34.50	3.90	67.01	34.50	4.27	62.34	32.84	31.12	31.12	5.17	52.44	29.35	5.70	47.35	27.57	
	57(13.8)	60.99	60.99	57.68	3.90	57.68	57.68	4.26	54.22	54.22	4.68	50.58	50.58	5.15	46.74	46.74	5.68	42.79	42.79
1750	62(16.6)	61.23	60.84	57.75	3.90	57.75	57.75	4.26	54.29	54.29	4.68	50.64	50.64	5.15	46.80	46.80	5.68	42.83	42.83
	63*(17.2)	61.92	45.99	44.25	3.91	57.99	44.25	4.26	53.95	42.45	40.60	40.60	5.13	45.40	38.65	5.65	41.00	36.66	
	67(19.4)	66.43	47.87	46.10	3.94	62.19	46.10	4.30	57.80	44.27	42.39	42.39	5.19	48.55	40.42	5.71	43.81	38.42	
	72(22.2)	72.71	38.07	36.40	3.98	68.00	36.40	4.35	63.17	34.70	32.94	32.94	5.26	52.95	31.12	5.78	47.73	29.31	
	57(13.8)	62.91	62.91	59.42	3.99	59.42	59.42	4.35	55.76	55.76	4.77	51.93	51.93	5.25	47.89	47.89	5.78	43.74	43.74
	62(16.6)	62.99	62.99	59.49	3.99	59.49	59.49	4.36	55.83	55.83	4.77	51.99	51.99	5.25	47.94	47.94	5.78	43.79	43.79
2000	63*(17.2)	62.73	48.75	46.95	3.99	58.69	46.95	4.35	54.54	45.08	43.14	43.14	5.22	45.80	41.08	5.73	41.35	38.84	
	67(19.4)	67.27	50.85	49.01	4.02	62.89	49.01	4.39	58.40	47.12	45.15	45.15	5.27	48.94	43.08	5.80	44.15	40.88	
	72(22.2)	73.56	39.95	38.24	4.06	68.73	38.24	4.43	63.76	36.50	34.70	34.70	5.34	53.29	32.85	5.87	47.96	31.01	
	57(13.8)	60.99	60.99	57.68	3.90	57.68	57.68	4.26	54.22	54.22	4.68	50.58	50.58	5.15	46.74	46.74	5.68	42.79	42.79
	62(16.6)	61.23	60.84	57.75	3.90	57.75	57.75	4.26	54.29	54.29	4.68	50.64	50.64	5.15	46.80	46.80	5.68	42.83	42.83
	63*(17.2)	61.92	45.99	44.25	3.91	57.99	44.25	4.26	53.95	42.45	40.60	40.60	5.13	45.40	38.65	5.65	41.00	36.66	
2250	67(19.4)	66.43	47.87	46.10	3.94	62.19	46.10	4.30	57.80	44.27	42.39	42.39	5.19	48.55	40.42	5.71	43.81	38.42	
	72(22.2)	72.71	38.07	36.40	3.98	68.00	36.40	4.35	63.17	34.70	32.94	32.94	5.26	52.95	31.12	5.78	47.73	29.31	
	57(13.8)	62.91	62.91	59.42	3.99	59.42	59.42	4.35	55.76	55.76	4.77	51.93	51.93	5.25	47.89	47.89	5.78	43.74	43.74
	62(16.6)	62.99	62.99	59.49	3.99	59.49	59.49	4.36	55.83	55.83	4.77	51.99	51.99	5.25	47.94	47.94	5.78	43.79	43.79
	63*(17.2)	62.73	48.75	46.95	3.99	58.69	46.95	4.35	54.54	45.08	43.14	43.14	5.22	45.80	41.08	5.73	41.35	38.84	
	67(19.4)	67.27	50.85	49.01	4.02	62.89	49.01	4.39	58.40	47.12	45.15	45.15	5.27	48.94	43.08	5.80	44.15	40.88	

See Legend and Notes on Page 18.

PERFORMANCE DATA (CONT)

* At 75°F (24°C) entering dry bulb- Tennessee Valley Authority (TVA) rating conditions; all others at 80°F (27°C) dry bulb.

LEGEND

BF— Bypass Factor
 edb— Entering Dry- Bulb
 Ewb— Entering Wet- Bulb
 kW — Total Unit Power Input
 SHC— Sensible Heat Capacity (1000 Btuh)
 TC — Total Capacity (1000 Btuh) (net)
 rh—Relative Humidity

COOLING NOTES:

1. Ratings are net; they account for the effects of the evaporator-fan motor power and heat.
2. Direct interpolation is permissible. Do not extrapolate.
3. The following formulas may be used:

$$t_{db} = t_{edb} - \frac{\text{Sensible capacity (Btuh)}}{1,10 \times \text{cfm}}$$

$$t_{lwb} = \text{Wet- bulb temperature corresponding to enthalpy air leaving evaporator coil (} t_{lwb} \text{)} \quad h_{lwb} = h_{ewb} - \frac{\text{total capacity (Btuh)}}{4.5 \times \text{cfm}}$$

Where: h_{ewb} = Enthalpy of air entering evaporator coil

4. The SHC is based on 805 F (26.6°C) edb temperature of air entering evaporator coil. Below 80° F (26.6°C) edb, subtract (corr factor x cfm) from SHC. Above 80° F (26.6°C) edb, add (corr factor x cfm) to SHC.

Correction Factor = $1,10 \times (1 + BF) \times (edb - 80)$.

5. Integrated capacity is maximum (instantaneous) capacity less the effect of frost on the outdoor coil and the heat required to defrost it.

PERFORMANCE DATA (CONT)

GAS ADJUSTMENT

Natural Gas Orifice Sizes and Manifold Pressure

208/230VAC Models

Nameplate Input, High Stage (Btu/hr)		ALTITUDE OF INSTALLATION (FT. [m] ABOVE SEA LEVEL) U.S.A.*				
		0 to 2000 [0 to 610]	2001 to 3000* [610 to 914]	3001 to 4000 [915 to 1219]	4001 to 5000 [1220 to 1524]	5001 to 6000 [1524 to 1829]
40000	Orifice No. (Qty)	44 (2)	45 (2)†	48 (2)†	48 (2)†	48 (2)†
	Manifold Press. High / Low (in. W.C.)	3.2 / 1.4	3.2 / 1.4	3.8 / 1.6	3.5 / 1.5	3.2 / 1.4
60000	Orifice No. (Qty)	44 (3)	45 (3)†	48 (3)†	48 (3)†	48 (3)†
	Manifold Press. High / Low (in. W.C.)	3.2 / 1.4	3.2 / 1.4	3.8 / 1.6	3.5 / 1.5	3.2 / 1.4
90000	Orifice No. (Qty)	38 (3)	41 (3)†	41 (3)†	42 (3)†	42 (3)†
	Manifold Press. High / Low (in. W.C.)	3.6 / 1.6	3.8 / 1.6	3.4 / 1.5	3.4 / 1.5	3.2 / 1.4
115000	Orifice No. (Qty)	33 (3)	36 (3)†	36 (3)†	36 (3)†	38 (3)†
	Manifold Press. High / Low (in. W.C.)	3.8 / 1.7	3.8 / 1.7	3.6 / 1.6	3.3 / 1.4	3.6 / 1.5
127000 (1- Phase)	Orifice No. (Qty)	31 (3)	31 (3)	33 (3)†	33 (3)†	34 (3)†
	Manifold Press. High / Low (in. W.C.)	3.7 / 1.7	3.2 / 1.4	3.5 / 1.6	3.2 / 1.4	3.2 / 1.4
130000 (3- Phase)	Orifice No. (Qty)	31 (3)	31 (3)	33 (3)†	33 (3)†	34 (3)†
	Manifold Press. High / Low (in. W.C.)	3.8 / 1.7	3.2 / 1.4	3.7 / 1.6	3.4 / 1.4	3.3 / 1.4

Propane Gas Orifice Sizes and Manifold Pressure

208/230VAC Models

Nameplate Input, High Stage (Btu/hr)		ALTITUDE OF INSTALLATION (FT. ABOVE SEA LEVEL) U.S.A.*†				
		0 to 2000 [0 to 610]	2001 to 3000* [610 to 914]	3001 to 4000 [915 to 1219]	4001 to 5000 [1220 to 1524]	5001 to 6000 [1524 to 1829]
40000	Orifice No. (Qty)	55 (2)	56 (2)	56 (2)	56 (2)	56 (2)
	Manifold Press. High / Low (in. W.C.)	10.0/5.0	11.0/6.0	11.0/5.5	11.0/5.0	10.7/4.8
60000	Orifice No. (Qty)	55 (3)	56 (3)	56 (3)	56 (3)	56 (3)
	Manifold Press. High / Low (in. W.C.)	10.0/5.0	11.0/6.0	11.0/5.5	11.0/5.0	10.7/4.8
90000	Orifice No. (Qty)	53 (3)	54 (3)	54 (3)	54 (3)	54 (3)
	Manifold Press. High / Low (in. W.C.)	10.0/5.4	11.0/6.4	11.0/5.9	11.0/5.4	11.0/5.0
115000	Orifice No. (Qty)	51 (3)	52 (3)	52 (3)	53 (3)	53 (3)
	Manifold Press. High / Low (in. W.C.)	10.0/5.4	11.0/5.0	10.6/4.8	11.0/6.1	11.0/5.5
127000 (1- Phase) or 130000 (3- Phase)	Orifice No. (Qty)	49 (3)	50 (3)	51 (3)	52 (3)	52 (3)
	Manifold Press. High / Low (in. W.C.)	10.0/5.4	11.0/4.8	11.0/4.9	11.0/5.2	11.0/5.0

*In the U.S.A., the input rating for altitudes above 2000 ft (610m) must be reduced by 4% for each 1000 ft (305 m) above sea level.

In Canada, the input rating for altitudes from 2001 to 4500 ft (611 to 1372 m) above sea level must be derated by 10% by an authorized gas conversion station or dealer.

For Canadian Installations from 2000 to 4500 ft, use U.S.A. column 2001 to 3000 ft (610 to 914 m).

† Use Kit No. NPLPCONV013C00 (0- 2000 ft [0- 610 m] above sea level). Use Kit No. NPLPCONV014C00 (2001- 6000 ft [611- 1829 m] above sea level).

High Altitude Compensation: Natural Gas

208/230VAC Models

Nameplate Input, High Stage (Btu/hr)	Rated Heating Input (Btu/hr), Natural Gas at Installation Altitude Above Sea Level, U.S.A.*									
	0 to 2000 ft 0 to 610 m		2001 to 3000 ft* 610 to 914 m		3001 to 4000 ft 915 to 1219 m		4001 to 5000 ft 1220 to 1524 m		5001 to 6000 ft 1524 to 1829 m	
	High Stage	Low Stage	High Stage	Low Stage	High Stage	Low Stage	High Stage	Low Stage	High Stage	Low Stage
40000	40000	26000	36000	23400	34400	22300	32800	21300	31200	20300
60000	60000	39000	54000	35100	51600	33500	49200	32000	46800	30400
90000	90000	58500	81000	52700	77400	50300	73800	48000	70200	45600
115000	115000	75000	103500	67500	98900	64500	94300	61500	89700	58500
127000 (1- Phase)	127000	84500	114300	76100	109200	72700	104100	69300	99100	65900
130000 (3- Phase)	130000	84500	117000	76100	111800	72700	106600	69300	101400	65900

High Altitude Compensation: Propane Gas

208/230VAC Models

Nameplate Input, High Stage (Btu/hr)	Rated Heating Input (Btu/hr), LP Gas at Installation Altitude Above Sea Level, U.S.A.*									
	0 to 2000 ft 0 to 610 m		2001 to 3000 ft* 610 to 914 m		3001 to 4000 ft 915 to 1219 m		4001 to 5000 ft 1220 to 1524 m		5001 to 6000 ft 1524 to 1829 m	
	High Stage	Low Stage	High Stage	Low Stage	High Stage	Low Stage	High Stage	Low Stage	High Stage	Low Stage
40000	38000	26000	31700	23400	31700	22300	31700	21300	31200	20300
60000	57000	39000	47500	35100	47500	33500	47500	32000	46800	30400
90000	79000	58500	68900	52700	68900	50300	68600	48000	68600	45600
115000	103000	75000	100400	67500	98900	64500	83000	61500	83000	58500
127000 (1- Phase) or 130000 (3- Phase)	116000	84500	115500	76100	111800	72700	101300	69300	100400	65900

*In the U.S.A., the input rating for altitudes above 2000 ft (610m) must be reduced by 4% for each 1000 ft (305 m) above sea level.

In Canada, the input rating for altitudes from 2001 to 4500 ft (611 to 1372 m) above sea level must be derated by 10% by an authorized gas conversion station or dealer.

For Canadian Installations from 2000 to 4500 ft (610- 1372 m), use U.S.A. column 2001 to 3000 ft (611 to 914 m).

DRY COIL AIR DELIVERY* - HORIZONTAL AND DOWNFLOW DISCHARGE - 208/230 VAC SINGLE PHASE MODELS (CONT)

UNIT-SIZE	HEATING RISE RANGE	MOTOR-SPEED	WIRE COLOR	EXTERNAL STATIC PRESSURE (IN. W.C.)															
				0.1	0.2	0.3	0.4	0.5	0.6	0.7	0.8	0.9	1						
30040	25 - 55°F Low Stage, 25 - 55°F High Stage	Low ³	Blue	CFM	714	525	---	---	---	---	---	---	---	---	---	---	---	---	
				BHP	0.08	0.07	---	---	---	---	---	---	---	---	---	---	---	---	---
				Low Stage Heat Rise °F (°C)	27(15)	37(21)	NA	NA	NA	NA	NA	NA	NA	NA	NA	NA	NA	NA	NA
		Med-Low ¹	Pink	CFM	831	765	670	586	466	299	---	---	---	---	---	---	---	---	---
				BHP	0.11	0.12	0.12	0.13	0.13	0.14	---	---	---	---	---	---	---	---	---
				Low Stage Heat Rise °F (°C)	26(14)	29(16)	29(16)	33(19)	42(23)	NA	NA	NA	NA	NA	NA	NA	NA	NA	NA
	Medium ⁴	Red	CFM	831	765	670	586	466	299	---	---	---	---	---	---	---	---	---	
			BHP	0.11	0.12	0.12	0.13	0.13	0.14	---	---	---	---	---	---	---	---	---	
			Low Stage Heat Rise °F (°C)	26(14)	29(16)	29(16)	33(19)	42(23)	NA	NA	NA	NA	NA	NA	NA	NA	NA	NA	
	Med-High ²	Orange	CFM	1139	1069	1012	937	870	786	724	626	512	381	---	---	---	---	---	
			BHP	0.22	0.23	0.24	0.24	0.25	0.26	0.26	0.27	0.27	0.28	---	---	---	---	---	
			Low Stage Heat Rise °F (°C)	26(15)	28(16)	30(16)	32(18)	34(19)	38(21)	41(23)	48(27)	NA	NA	NA	NA	NA	NA	NA	
High	Black	CFM	1531	1460	1382	1301	1209	1114	1003	890	764	629	---	---	---	---	---		
		BHP	0.53	0.52	0.50	0.48	0.46	0.44	0.42	0.40	0.37	0.35	---	---	---	---	---		
		Low Stage Heat Rise °F (°C)	NA	NA	NA	NA	NA	NA	NA	NA	NA	NA	NA	NA	NA	NA	NA		

UNIT-SIZE	HEATING RISE RANGE	MOTOR-SPEED	WIRE COLOR	EXTERNAL STATIC PRESSURE (IN. W.C.)															
				0.1	0.2	0.3	0.4	0.5	0.6	0.7	0.8	0.9	1						
30060	25 - 55°F Low Stage, 25 - 55°F High Stage	Low ³	Blue	CFM	714	525	---	---	---	---	---	---	---	---	---	---	---	---	
				BHP	0.08	0.07	---	---	---	---	---	---	---	---	---	---	---	---	---
				Low Stage Heat Rise °F (°C)	41(23)	55(31)	NA	NA	NA	NA	NA	NA	NA	NA	NA	NA	NA	NA	NA
		Med-Low ¹	Pink	CFM	831	765	670	586	466	299	---	---	---	---	---	---	---	---	---
				BHP	0.11	0.12	0.12	0.13	0.13	0.14	---	---	---	---	---	---	---	---	---
				Low Stage Heat Rise °F (°C)	35(20)	38(21)	44(24)	50(28)	NA	NA	NA	NA	NA	NA	NA	NA	NA	NA	NA
	Medium ²	Red	CFM	1139	1069	1012	937	870	786	724	626	512	381	---	---	---	---	---	
			BHP	0.22	0.23	0.24	0.24	0.25	0.26	0.26	0.27	0.27	0.28	---	---	---	---	---	
			Low Stage Heat Rise °F (°C)	26(14)	28(15)	29(16)	31(17)	34(19)	37(21)	41(23)	47(26)	NA	NA	NA	NA	NA	NA	NA	
	Med-High ⁴	Orange	CFM	1229	1171	1105	1049	980	913	838	775	679	516	---	---	---	---	---	
			BHP	0.28	0.30	0.30	0.31	0.32	0.33	0.33	0.34	0.34	0.33	---	---	---	---	---	
			Low Stage Heat Rise °F (°C)	37(20)	39(21)	41(23)	43(24)	46(26)	50(28)	54(30)	62(34)	74(42)	89(51)	109(61)	139(76)	179(100)	229(130)	289(160)	
High	Black	CFM	1531	1460	1382	1301	1209	1114	1003	890	764	629	---	---	---	---	---		
		BHP	0.53	0.52	0.50	0.48	0.46	0.44	0.42	0.40	0.37	0.35	---	---	---	---	---		
		Low Stage Heat Rise °F (°C)	NA	NA	NA	NA	NA	NA	NA	NA	NA	NA	NA	NA	NA	NA	NA		

DRY COIL AIR DELIVERY* - HORIZONTAL AND DOWNFLOW DISCHARGE - 208/230 VAC SINGLE PHASE MODELS (CONT)

UNIT-SIZE	HEATING RISE RANGE	MOTOR-SPEED	WIRE COLOR	EXTERNAL STATIC PRESSURE (IN. W.C.)																
				0.1	0.2	0.3	0.4	0.5	0.6	0.7	0.8	0.9	1							
36060	25 - 55°F Low Stage, 25 - 55°F High Stage	Low ³	Blue	CFM	694	624	533	460	383	328	---	---	---	---	---	---	---			
				BHP	0.05	0.05	0.06	0.07	0.07	0.08	---	---	---	---	---	---				
				Low Stage Heat Rise °F (°C)	42(24)	47(26)	55(31)	NA	NA	NA	NA	NA	NA	NA	NA	NA	NA	NA	NA	NA
				High Stage Heat Rise °F (°C)	NA	NA	NA	NA	NA	NA	NA	NA	NA	NA	NA	NA	NA	NA	NA	NA
				CFM	934	864	810	745	698	649	571	525	486	428	---	---	---	---	---	---
				BHP	0.10	0.10	0.11	0.12	0.13	0.14	0.14	0.15	0.16	0.17	---	---	---	---	---	---
	Med-Low ¹	Low Stage Heat Rise °F (°C)	32(18)	34 (19)	36(20)	39(22)	42(23)	45(25)	52(29)	NA	NA	NA	NA	NA	NA	NA	NA	NA		
		High Stage Heat Rise °F (°C)	48(27)	52(29)	NA	NA	NA	NA	NA	NA	NA	NA	NA	NA	NA	NA	NA	NA		
		CFM	1213	1169	1110	1065	1016	964	923	878	820	777	---	---	---	---	---	---		
		BHP	0.16	0.17	0.17	0.19	0.20	0.21	0.22	0.23	0.24	0.25	---	---	---	---	---	---		
		Low Stage Heat Rise °F (°C)	NA	25(14)	27(15)	28(15)	29(16)	31(17)	32(18)	34(19)	36(20)	38(21)	---	---	---	---	---	---		
		High Stage Heat Rise °F (°C)	37(21)	39(21)	41(23)	42(24)	45(25)	47(26)	49(27)	51(29)	55(31)	NA	---	---	---	---	---	---		
Med-High ²	CFM	1251	1198	1149	1104	1066	1017	970	932	892	839	---	---	---	---	---	---			
	BHP	0.19	0.21	0.21	0.23	0.24	0.25	0.26	0.27	0.28	0.29	---	---	---	---	---	---			
	Low Stage Heat Rise °F (°C)	NA	25(14)	26(14)	27(15)	28(15)	29(16)	30(17)	32(18)	33(18)	35(19)	---	---	---	---	---	---			
	High Stage Heat Rise °F (°C)	36(20)	38(21)	39(22)	41(23)	42(24)	44(25)	47(26)	49(27)	51(28)	54(30)	---	---	---	---	---	---			
	CFM	1466	1423	1384	1343	1308	1263	1219	1183	1145	1106	---	---	---	---	---	---			
	BHP	0.30	0.31	0.33	0.34	0.35	0.36	0.37	0.38	0.40	0.41	---	---	---	---	---	---			
High	Low Stage Heat Rise °F (°C)	NA	NA	NA	NA	NA	NA	NA	NA	NA	NA	NA	NA	NA	NA	NA	NA			
	High Stage Heat Rise °F (°C)	31(17)	32(18)	33(18)	34(19)	35(19)	36(20)	37(21)	38(21)	39(22)	41(23)	---	---	---	---	---	---			

UNIT-SIZE	HEATING RISE RANGE	MOTOR-SPEED	WIRE COLOR	EXTERNAL STATIC PRESSURE (IN. W.C.)																
				0.1	0.2	0.3	0.4	0.5	0.6	0.7	0.8	0.9	1							
36090	35 - 65°F Low Stage, 35 - 65°F High Stage	Low ³	Blue	CFM	882	737	665	608	542	496	437	395	339	288	238	177	---	---		
				BHP	0.10	0.10	0.11	0.12	0.13	0.14	0.14	0.15	0.16	0.17	---	---	---	---	---	
				Low Stage Heat Rise °F (°C)	50(28)	60(33)	NA	NA	NA	NA	NA	NA	NA	NA	NA	NA	NA	NA	NA	NA
				High Stage Heat Rise °F (°C)	NA	NA	NA	NA	NA	NA	NA	NA	NA	NA	NA	NA	NA	NA	NA	NA
				CFM	934	864	810	745	698	649	571	525	486	428	---	---	---	---	---	---
				BHP	0.10	0.10	0.11	0.12	0.13	0.14	0.14	0.15	0.16	0.17	---	---	---	---	---	---
	Med-Low ¹	Low Stage Heat Rise °F (°C)	47(26)	51(29)	55(30)	NA	NA	NA	NA	NA	NA	NA	NA	NA	NA	NA	NA	NA		
		High Stage Heat Rise °F (°C)	NA	NA	NA	NA	NA	NA	NA	NA	NA	NA	NA	NA	NA	NA	NA	NA		
		CFM	1251	1198	1149	1104	1066	1017	970	932	892	839	---	---	---	---	---	---		
		BHP	0.19	0.21	0.21	0.23	0.24	0.25	0.26	0.27	0.28	0.29	---	---	---	---	---	---		
		Low Stage Heat Rise °F (°C)	35(20)	37(21)	39(21)	40(22)	42(23)	44(24)	46(25)	48(26)	50(29)	53(29)	---	---	---	---	---	---		
		High Stage Heat Rise °F (°C)	54(30)	57(31)	59(33)	61(34)	64(35)	NA	NA	NA	NA	NA	---	---	---	---	---	---		
Med-High ⁴	CFM	1359	1311	1267	1224	1187	1140	1095	1058	1019	973	---	---	---	---	---	---			
	BHP	0.25	0.26	0.27	0.28	0.29	0.31	0.31	0.33	0.34	0.35	---	---	---	---	---	---			
	Low Stage Heat Rise °F (°C)	NA	NA	35(19)	36(20)	37(21)	39(22)	41(23)	42(23)	44(24)	46(25)	---	---	---	---	---	---			
	High Stage Heat Rise °F (°C)	50(28)	52(29)	54(30)	55(31)	57(32)	60(33)	62(34)	64(36)	66(36)	68(36)	---	---	---	---	---	---			
	CFM	1466	1423	1384	1343	1308	1263	1219	1183	1145	1106	---	---	---	---	---	---			
	BHP	0.30	0.31	0.33	0.34	0.35	0.36	0.37	0.38	0.40	0.41	---	---	---	---	---	---			
High	Low Stage Heat Rise °F (°C)	NA	NA	NA	NA	NA	NA	NA	NA	NA	NA	NA	NA	NA	NA	NA	NA			
	High Stage Heat Rise °F (°C)	46(26)	48(26)	49(27)	51(28)	52(29)	54(30)	56(31)	57(32)	59(33)	61(34)	---	---	---	---	---	---			

DRY COIL AIR DELIVERY* - HORIZONTAL AND DOWNFLOW DISCHARGE - 208/230 VAC SINGLE PHASE MODELS (CONT)

UNIT-SIZE	HEATING RISE RANGE	MOTOR-SPEED	WIRE COLOR	EXTERNAL STATIC PRESSURE (IN. W.C.)																
				0.1	0.2	0.3	0.4	0.5	0.6	0.7	0.8	0.9	1							
42060	25 - 55°F Low Stage, 25 - 55°F High Stage	Low ³	Blue	CFM	694	624	533	460	383	328	---	---	---	---	---	---	---			
				BHP	0.05	0.05	0.06	0.07	0.07	0.08	---	---	---	---	---					
				Low Stage Heat Rise °F (°C)	42(24)	47(26)	55(31)	NA	NA	NA	NA	NA	NA	NA	NA	NA	NA	NA	NA	NA
				High Stage Heat Rise °F (°C)	NA	NA	NA	NA	NA	NA	NA	NA	NA	NA	NA	NA	NA	NA	NA	NA
				CFM	1076	1026	972	918	872	827	771	714	666	611	---	---	---	---	---	---
				BHP	0.13	0.14	0.15	0.15	0.17	0.18	0.18	0.20	0.21	0.22	---	---	---	---	---	---
	Med-Low ¹	Low Stage Heat Rise °F (°C)	27(15)	29(16)	30(17)	32(18)	34(19)	36(20)	38(21)	41(23)	44(25)	48(27)	---	---	---	---	---	---		
		High Stage Heat Rise °F (°C)	42(23)	44(24)	47(26)	49(27)	52(29)	55(30)	NA	NA	NA	NA	NA	NA	NA	NA	NA	NA		
		CFM	1213	1169	1110	1065	1016	964	923	878	820	777	---	---	---	---	---	---		
		BHP	0.16	0.17	0.17	0.19	0.20	0.21	0.22	0.23	0.24	0.25	---	---	---	---	---	---		
		Low Stage Heat Rise °F (°C)	NA	25(14)	27(15)	28(15)	29(16)	31(17)	32(18)	34(19)	36(20)	38(21)	---	---	---	---	---	---		
		High Stage Heat Rise °F (°C)	37(21)	39(21)	41(23)	42(24)	45(25)	47(26)	49(27)	51(29)	55(31)	NA	NA	NA	NA	NA	NA	NA		
Med-High ²	CFM	1451	1415	1372	1327	1287	1249	1212	1168	1130	1094	---	---	---	---	---	---			
	BHP	0.29	0.30	0.31	0.32	0.32	0.35	0.36	0.37	0.38	0.39	---	---	---	---	---	---			
	Low Stage Heat Rise °F (°C)	NA	NA	NA	NA	NA	NA	NA	NA	NA	NA	NA	NA	NA	NA	NA	NA			
	High Stage Heat Rise °F (°C)	31(17)	32(18)	33(18)	34(19)	35(20)	36(20)	37(21)	39(22)	40(22)	41(23)	---	---	---	---	---	---			
	CFM	1633	1590	1552	1518	1483	1444	1406	1372	1340	1303	---	---	---	---	---	---			
	BHP	0.41	0.43	0.44	0.45	0.47	0.48	0.49	0.50	0.51	0.53	---	---	---	---	---	---			
High	Low Stage Heat Rise °F (°C)	NA	NA	NA	NA	NA	NA	NA	NA	NA	NA	NA	NA	NA	NA	NA	NA			
	High Stage Heat Rise °F (°C)	28(15)	28(16)	29(16)	30(17)	30(17)	31(17)	32(18)	33(18)	34(19)	35(19)	---	---	---	---	---	---			

UNIT-SIZE	HEATING RISE RANGE	MOTOR-SPEED	WIRE COLOR	EXTERNAL STATIC PRESSURE (IN. W.C.)																	
				0.1	0.2	0.3	0.4	0.5	0.6	0.7	0.8	0.9	1								
42090	35 - 65°F Low Stage, 35 - 65°F High Stage	Low ³	Blue	CFM	882	737	665	608	542	496	437	395	339	288	237	186	135	84			
				BHP	0.10	0.10	0.11	0.12	0.13	0.14	0.15	0.16	0.17	0.18	0.19	0.20	0.21	0.22	0.23		
				Low Stage Heat Rise °F (°C)	50(28)	60(33)	NA	NA	NA	NA	NA	NA	NA	NA	NA	NA	NA	NA	NA	NA	NA
				High Stage Heat Rise °F (°C)	NA	NA	NA	NA	NA	NA	NA	NA	NA	NA	NA	NA	NA	NA	NA	NA	NA
				CFM	1076	1026	972	918	872	827	771	714	666	611	566	511	466	421	376	331	
				BHP	0.13	0.14	0.15	0.15	0.17	0.18	0.18	0.20	0.21	0.22	0.23	0.24	0.25	0.26	0.27	0.28	0.29
	Med-Low ¹	Low Stage Heat Rise °F (°C)	41(23)	43(24)	46(25)	48(27)	51(28)	54(30)	58(32)	62(35)	66(38)	70(41)	74(44)	78(47)	82(50)	86(53)	90(56)	94(59)			
		High Stage Heat Rise °F (°C)	62(35)	65(36)	NA	NA	NA	NA	NA	NA	NA	NA	NA	NA	NA	NA	NA	NA			
		CFM	1359	1311	1267	1224	1187	1140	1095	1058	1019	973	937	891	845	799	753	707			
		BHP	0.25	0.26	0.27	0.28	0.29	0.31	0.31	0.33	0.34	0.35	0.36	0.37	0.38	0.39	0.40	0.41			
		Low Stage Heat Rise °F (°C)	NA	NA	35(19)	36(20)	37(21)	39(22)	41(23)	42(23)	44(24)	46(25)	48(26)	50(27)	52(28)	54(29)	56(30)	58(31)			
		High Stage Heat Rise °F (°C)	50(28)	52(29)	54(30)	55(31)	57(32)	60(33)	62(34)	64(36)	66(37)	68(38)	70(40)	72(41)	74(42)	76(43)	78(44)	80(45)			
Med-High ²	CFM	1451	1415	1372	1327	1287	1249	1212	1168	1130	1094	1058	1019	973	937	891	845				
	BHP	0.29	0.30	0.31	0.32	0.32	0.35	0.36	0.37	0.38	0.39	0.40	0.41	0.42	0.43	0.44	0.45				
	Low Stage Heat Rise °F (°C)	NA	NA	NA	NA	NA	NA	NA	NA	NA	NA	NA	NA	NA	NA	NA	NA				
	High Stage Heat Rise °F (°C)	46(26)	47(26)	49(27)	51(28)	52(29)	54(30)	55(31)	57(32)	59(33)	61(34)	63(35)	65(36)	67(37)	69(38)	71(39)	73(40)				
	CFM	1633	1590	1552	1518	1483	1444	1406	1372	1340	1303	1269	1235	1201	1167	1133	1099				
	BHP	0.41	0.43	0.44	0.45	0.47	0.48	0.49	0.50	0.51	0.53	0.54	0.55	0.56	0.57	0.58	0.59				
High	Low Stage Heat Rise °F (°C)	NA	NA	NA	NA	NA	NA	NA	NA	NA	NA	NA	NA	NA	NA	NA	NA				
	High Stage Heat Rise °F (°C)	41(23)	42(23)	43(24)	44(25)	45(25)	46(26)	48(27)	49(27)	50(28)	51(29)	52(29)	53(30)	54(30)	55(31)	56(31)	57(32)				

DRY COIL AIR DELIVERY* - HORIZONTAL AND DOWNFLOW DISCHARGE - 208/230 VAC SINGLE PHASE MODELS (CONT)

UNIT- SIZE	HEATING RISE RANGE	MOTOR- SPEED	WIRE COLOR	EXTERNAL STATIC PRESSURE (IN. W.C.)											
				0.1	0.2	0.3	0.4	0.5	0.6	0.7	0.8	0.9	1		
48090	35 - 65°F Low Stage, 35 - 65°F High Stage	Low ³	Blue	CFM	903	820	749	702	645	581	534	468	432	382	
				BHP	0.11	0.12	0.12	0.13	0.14	0.14	0.16	0.16	0.17	0.18	
				Low Stage Heat Rise °F (°C)	49(27)	54(30)	59(33)	63(35)	NA	NA	NA	NA	NA	NA	NA
		High Stage Heat Rise °F (°C)		NA	NA	NA	NA	NA	NA	NA	NA	NA	NA	NA	NA
		CFM		1271	1229	1177	1121	1066	1027	974	942	887	839		
		BHP		0.19	0.20	0.21	0.23	0.24	0.25	0.26	0.27	0.28	0.29		
	Medium ⁴	Med-Low ¹	Pink	Low Stage Heat Rise °F (°C)	35(19)	36(20)	38(21)	40(22)	42(23)	43(24)	46(25)	47(26)	50(28)	53(29)	
				High Stage Heat Rise °F (°C)	53(30)	55(31)	58(32)	61(34)	63(35)	64(35)	NA	NA	NA	NA	
				CFM	1386	1336	1304	1259	1230	1186	1147	1102	1052	1022	
		BHP		0.32	0.33	0.34	0.35	0.36	0.37	0.39	0.39	0.40	0.42		
		Low Stage Heat Rise °F (°C)		NA	NA	NA	35(20)	36(20)	37(21)	39(21)	40(22)	42(23)	43(24)		
		High Stage Heat Rise °F (°C)		49(27)	51(28)	52(29)	54(30)	55(31)	57(32)	59(33)	62(34)	64(36)	NA		
High	Med-High ²	Orange	CFM	1686	1650	1617	1576	1544	1503	1468	1433	1393	1356		
			BHP	0.42	0.44	0.45	0.46	0.48	0.49	0.51	0.52	0.53	0.55		
			Low Stage Heat Rise °F (°C)	NA	NA	NA	NA	NA	NA	NA	NA	NA	NA		
	High Stage Heat Rise °F (°C)		40(22)	41(23)	42(23)	43(24)	44(24)	45(25)	46(26)	47(26)	49(27)	50(28)			
	CFM		1854	1837	1781	1784	1720	1698	1655	1625	1578	1532			
	BHP		0.56	0.57	0.60	0.59	0.62	0.63	0.64	0.66	0.67	0.67			
High	High	Black	Low Stage Heat Rise °F (°C)	NA	NA	NA	NA	NA	NA	NA	NA	NA	NA		
			High Stage Heat Rise °F (°C)	37(20)	37(21)	38(21)	38(21)	39(22)	40(22)	41(23)	42(23)	43(24)	44(25)		

UNIT- SIZE	HEATING RISE RANGE	MOTOR- SPEED	WIRE COLOR	EXTERNAL STATIC PRESSURE (IN. W.C.)										
				0.1	0.2	0.3	0.4	0.5	0.6	0.7	0.8	0.9	1	
48115	30 - 60°F Low Stage,30 - 60°F High Stage	Low ¹	Blue	CFM	1271	1229	1177	1121	1066	1027	974	942	887	839
				BHP	0.19	0.20	0.21	0.23	0.24	0.25	0.26	0.27	0.28	0.29
				Low Stage Heat Rise °F (°C)	45(25)	46(26)	48(27)	51(28)	53(30)	55(31)	58(32)	60(33)	NA	NA
		High Stage Heat Rise °F (°C)		NA	NA	NA	NA	NA	NA	NA	NA	NA	NA	NA
		CFM		1340	1299	1240	1191	1139	1091	1050	1001	952	895	
		BHP		0.22	0.23	0.24	0.25	0.26	0.28	0.29	0.30	0.31	0.32	
	Med-Low ³	Med-Low ³	Pink	Low Stage Heat Rise °F (°C)	42(24)	44(24)	46(25)	48(26)	50(28)	52(29)	54(30)	57(31)	60(33)	NA
				High Stage Heat Rise °F (°C)	NA	NA	NA	NA	NA	NA	NA	NA	NA	NA
				CFM	1686	1650	1617	1576	1544	1503	1468	1433	1393	1356
		BHP		0.42	0.44	0.45	0.46	0.48	0.49	0.51	0.52	0.53	0.55	
		Low Stage Heat Rise °F (°C)		34(19)	34(19)	35(19)	36(20)	37(20)	38(21)	39(21)	40(22)	41(23)	42(23)	
		High Stage Heat Rise °F (°C)		51(29)	52(29)	54(30)	55(31)	56(31)	58(32)	59(33)	60(34)	NA	NA	
Med-High	Med-High	Orange	CFM	1854	1837	1781	1784	1720	1698	1655	1625	1578	1532	
			BHP	0.56	0.57	0.60	0.59	0.62	0.63	0.64	0.66	0.67	0.67	
			Low Stage Heat Rise °F (°C)	31(17)	31(17)	32(18)	32(18)	33(18)	33(19)	34(19)	35(19)	36(20)	37(21)	
	High Stage Heat Rise °F (°C)		47(26)	47(26)	49(27)	49(27)	50(28)	51(28)	52(29)	53(30)	55(30)	57(31)		
	CFM		1934	1900	1855	1815	1778	1737	1695	1656	1606	1528		
	BHP		0.59	0.61	0.62	0.64	0.65	0.67	0.68	0.70	0.70	0.68		
High ⁴	High ⁴	Black	Low Stage Heat Rise °F (°C)	NA	30(17)	31(17)	31(17)	32(18)	33(18)	33(18)	33(19)	34(19)	35(20)	
			High Stage Heat Rise °F (°C)	45(25)	46(25)	47(26)	48(27)	49(27)	50(28)	51(28)	52(29)	54(30)	57(31)	

DRY COIL AIR DELIVERY* - HORIZONTAL AND DOWNFLOW DISCHARGE - 208/230 VAC SINGLE PHASE MODELS (CONT)

UNIT-SIZE	HEATING RISE RANGE	MOTOR-SPEED	WIRE COLOR	EXTERNAL STATIC PRESSURE (IN. W.C.)											
				0.1	0.2	0.3	0.4	0.5	0.6	0.7	0.8	0.9	1		
48130	35 - 65°F Low Stage, 35 - 65°F High Stage	Low ¹	Blue	CFM	1271	1229	1177	1121	1066	1027	974	942	887	839	
				BHP	0.19	0.20	0.21	0.23	0.24	0.25	0.26	0.27	0.28	0.29	
		Med-Low ³	Pink	Low Stage Heat Rise °F(°C)	50(28)	52(29)	54(30)	57(32)	60(33)	62(34)	65(36)	NA	NA	NA	NA
				High Stage Heat Rise °F(°C)	NA	NA	NA	NA	NA	NA	NA	NA	NA	NA	NA
		Medium ²	Red	CFM	1340	1299	1240	1191	1139	1091	1050	1001	952	895	
				BHP	0.22	0.23	0.24	0.25	0.26	0.28	0.29	0.30	0.31	0.32	
		Med-High	Orange	Low Stage Heat Rise °F(°C)	48(26)	49(27)	51(29)	54(30)	56(31)	58(32)	61(34)	64(35)	NA	NA	
				High Stage Heat Rise °F(°C)	NA	NA	NA	NA	NA	NA	NA	NA	NA	NA	
		High ⁴	Black	CFM	1686	1650	1617	1576	1544	1503	1468	1433	1393	1356	
				BHP	0.42	0.44	0.45	0.46	0.48	0.49	0.51	0.52	0.53	0.55	
		Low Stage Heat Rise °F(°C)	38(21)	39(21)	39(22)	40(22)	41(23)	42(24)	43(24)	44(25)	46(25)	47(26)			
		High Stage Heat Rise °F(°C)	57(32)	58(32)	59(33)	61(34)	62(34)	64(35)	65(36)	NA	NA	NA			
		CFM	1854	1837	1781	1784	1720	1698	1655	1625	1578	1532			
		BHP	0.56	0.57	0.60	0.59	0.62	0.63	0.64	0.66	0.67	0.67			
		Low Stage Heat Rise °F(°C)	NA	35(19)	36(20)	36(20)	37(21)	38(21)	39(21)	39(22)	40(22)	42(23)			
		High Stage Heat Rise °F(°C)	52(29)	52(29)	54(30)	54(30)	56(31)	56(31)	58(32)	59(33)	61(34)	63(35)			
		CFM	1934	1900	1855	1815	1778	1737	1695	1656	1606	1528			
		BHP	0.59	0.61	0.62	0.64	0.65	0.67	0.68	0.70	0.70	0.68			
		Low Stage Heat Rise °F(°C)	NA	NA	NA	35(20)	36(20)	37(20)	38(21)	38(21)	40(22)	42(23)			
		High Stage Heat Rise °F(°C)	50(28)	50(28)	52(29)	53(29)	54(30)	55(31)	57(31)	58(32)	60(33)	63(35)			

UNIT-SIZE	HEATING RISE RANGE	MOTOR-SPEED	WIRE COLOR	EXTERNAL STATIC PRESSURE (IN. W.C.)											
				0.1	0.2	0.3	0.4	0.5	0.6	0.7	0.8	0.9	1		
60090	35 - 65°F Low Stage, 35 - 65°F High Stage	Low ³	Blue	CFM	903	820	749	702	645	581	534	468	432	382	
				BHP	0.11	0.12	0.12	0.13	0.14	0.14	0.16	0.16	0.17	0.18	
		Med-Low ¹	Pink	Low Stage Heat Rise °F(°C)	49(27)	54(30)	59(33)	63(35)	NA	NA	NA	NA	NA	NA	NA
				High Stage Heat Rise °F(°C)	NA	NA	NA	NA	NA	NA	NA	NA	NA	NA	NA
		Medium ⁴	Red	CFM	1271	1229	1177	1121	1066	1027	974	942	887	839	
				BHP	0.19	0.20	0.21	0.23	0.24	0.25	0.26	0.26	0.27	0.28	0.29
		Med-High ²	Orange	Low Stage Heat Rise °F(°C)	35(19)	36(20)	38(21)	40(22)	42(23)	43(24)	46(25)	47(26)	50(28)	53(29)	
				High Stage Heat Rise °F(°C)	53(30)	55(31)	58(32)	61(34)	63(35)	64(35)	NA	NA	NA	NA	
				CFM	1386	1336	1304	1259	1230	1186	1147	1102	1052	1022	
				BHP	0.32	0.33	0.34	0.35	0.36	0.37	0.39	0.39	0.40	0.42	
		Low Stage Heat Rise °F(°C)	NA	NA	NA	35(20)	36(20)	37(21)	39(21)	40(22)	42(23)	43(24)			
		High Stage Heat Rise °F(°C)	49(27)	51(28)	52(29)	54(30)	55(31)	57(32)	59(33)	62(34)	64(36)	NA			
		CFM	1878	1844	1805	1762	1731	1693	1655	1616	1570	1532			
		BHP	0.50	0.52	0.53	0.54	0.56	0.57	0.59	0.60	0.64	0.63			
		Low Stage Heat Rise °F(°C)	NA	NA	NA	NA	NA	NA	NA	NA	NA	NA			
		High Stage Heat Rise °F(°C)	36(20)	37(20)	38(21)	38(21)	39(22)	40(22)	41(23)	42(23)	43(24)	44(25)			
		CFM	2020	1990	1956	1912	1872	1842	1802	1760	1719	1643			
		BHP	0.62	0.63	0.66	0.67	0.69	0.70	0.71	0.73	0.74	0.72			
		Low Stage Heat Rise °F(°C)	NA	NA	NA	NA	NA	NA	NA	NA	NA	NA			
		High Stage Heat Rise °F(°C)	NA	NA	35(19)	35(20)	36(20)	37(20)	38(21)	39(21)	39(22)	41(23)			

DRY COIL AIR DELIVERY* - HORIZONTAL AND DOWNFLOW DISCHARGE - 208/230 VAC SINGLE PHASE MODELS (CONT)

UNIT-SIZE	HEATING RISE RANGE	MOTOR-SPEED	WIRE COLOR	EXTERNAL STATIC PRESSURE (IN. W.C.)											
				0.1	0.2	0.3	0.4	0.5	0.6	0.7	0.8	0.9	1		
60115	30 - 60°F Low Stage	Low ¹	Blue	CFM	1271	1229	1177	1121	1066	1027	974	942	887	839	
				BHP	0.19	0.20	0.21	0.23	0.24	0.25	0.26	0.27	0.28	0.29	
	30 - 60°F High Stage	Med-Low ³	Pink	Low Stage Heat Rise °F(°C)	45 (25)	46(26)	48(27)	51 (28)	53 (30)	55 (31)	58(32)	60 (33)	NA	NA	
				High Stage Heat Rise °F(°C)	NA	NA	NA	NA	NA	NA	NA	NA	NA	NA	NA
	30 - 60°F High Stage	Med-Low ³	Pink	CFM	1340	1299	1240	1191	1139	1091	1050	1001	952	895	
				BHP	0.22	0.23	0.24	0.25	0.26	0.28	0.29	0.30	0.31	0.32	
	30 - 60°F High Stage	Med-Low ³	Pink	Low Stage Heat Rise °F(°C)	42 (24)	44 (24)	46(25)	48 (26)	50 (28)	52(29)	54 (30)	57(31)	60(33)	NA	
				High Stage Heat Rise °F(°C)	NA	NA	NA	NA	NA	NA	NA	NA	NA	NA	NA
	60130	35 - 65°F Low Stage,35 - 65°F High Stage	Low ¹	Blue	CFM	1686	1650	1617	1576	1544	1503	1468	1433	1393	1356
					BHP	0.42	0.44	0.45	0.46	0.48	0.49	0.51	0.52	0.53	0.55
35 - 65°F Low Stage,35 - 65°F High Stage		Med-High ²	Orange	Low Stage Heat Rise °F(°C)	34 (19)	34(19)	35 (19)	36(20)	37(20)	38(21)	39(21)	40 (22)	41 (23)	42 (23)	
				High Stage Heat Rise °F(°C)	51(29)	52 (29)	54 (30)	55 (31)	56(31)	58 (32)	59 (33)	60 (34)	NA	NA	
35 - 65°F Low Stage,35 - 65°F High Stage		Med-High ²	Orange	CFM	1878	1844	1805	1762	1731	1693	1655	1616	1570	1532	
				BHP	0.50	0.52	0.53	0.54	0.56	0.57	0.59	0.60	0.64	0.63	
35 - 65°F Low Stage,35 - 65°F High Stage		Med-High ²	Orange	Low Stage Heat Rise °F(°C)	30(17)	31 (17)	31(17)	32(18)	33 (18)	33(19)	34 (19)	35 (19)	36 (20)	37(21)	
				High Stage Heat Rise °F(°C)	46 (26)	47 (26)	48 (27)	49 (27)	50 (28)	51 (28)	52 (29)	54(30)	55 (31)	57(31)	
35 - 65°F Low Stage,35 - 65°F High Stage		Med-High ²	Orange	CFM	1934	1900	1855	1815	1778	1737	1695	1656	1606	1528	
				BHP	0.59	0.61	0.62	0.64	0.65	0.67	0.68	0.70	0.70	0.68	
35 - 65°F Low Stage,35 - 65°F High Stage	Med-High ²	Orange	Low Stage Heat Rise °F(°C)	NA	30 (17)	31(17)	31(17)	32 (18)	33(18)	33(19)	34(19)	35 (20)	37 (21)		
			High Stage Heat Rise °F(°C)	45 (25)	46(25)	47(26)	48(27)	49 (27)	50(28)	51(28)	52 (29)	54 (30)	57(31)		

UNIT-SIZE	HEATING RISE RANGE	MOTOR-SPEED	WIRE COLOR	EXTERNAL STATIC PRESSURE (IN. W.C.)										
				0.1	0.2	0.3	0.4	0.5	0.6	0.7	0.8	0.9	1	
60130	35 - 65°F Low Stage,35 - 65°F High Stage	Low ¹	Blue	CFM	1271	1229	1177	1121	1066	1027	974	942	887	839
				BHP	0.19	0.20	0.21	0.23	0.24	0.25	0.26	0.27	0.28	0.29
	35 - 65°F Low Stage,35 - 65°F High Stage	Med-Low ³	Pink	Low Stage Heat Rise °F(°C)	50(28)	52(29)	54 (30)	57(32)	60 (33)	62(34)	65(36)	NA	NA	
				High Stage Heat Rise °F(°C)	NA	NA	NA	NA	NA	NA	NA	NA	NA	NA
	35 - 65°F Low Stage,35 - 65°F High Stage	Med-Low ³	Pink	CFM	1340	1299	1240	1191	1139	1091	1050	1001	952	895
				BHP	0.22	0.23	0.24	0.25	0.26	0.28	0.29	0.30	0.31	0.32
	35 - 65°F Low Stage,35 - 65°F High Stage	Med-Low ³	Pink	Low Stage Heat Rise °F(°C)	48 (26)	49(27)	51(29)	54(30)	56(31)	58(32)	61(34)	64(35)	NA	NA
				High Stage Heat Rise °F(°C)	NA	NA	NA	NA	NA	NA	NA	NA	NA	NA
	35 - 65°F Low Stage,35 - 65°F High Stage	Med-Low ³	Pink	CFM	1686	1650	1617	1576	1544	1503	1468	1433	1393	1356
				BHP	0.42	0.44	0.45	0.46	0.48	0.49	0.51	0.52	0.53	0.55
35 - 65°F Low Stage,35 - 65°F High Stage	Med-Low ³	Pink	Low Stage Heat Rise °F(°C)	38 (21)	39 (21)	39(22)	40(22)	41(23)	42 (24)	43(24)	44(25)	46(25)	47(26)	
			High Stage Heat Rise °F(°C)	57(32)	58 (32)	59 (33)	61 (34)	62 (34)	64 (35)	65(36)	NA	NA	NA	
35 - 65°F Low Stage,35 - 65°F High Stage	Med-Low ³	Pink	CFM	1878	1844	1805	1762	1731	1693	1655	1616	1570	1532	
			BHP	0.50	0.52	0.53	0.54	0.56	0.57	0.59	0.60	0.64	0.63	
35 - 65°F Low Stage,35 - 65°F High Stage	Med-Low ³	Pink	Low Stage Heat Rise °F(°C)	NA	35 (19)	35(20)	36(20)	37(20)	38(21)	39(21)	39(22)	41(23)	42 (23)	
			High Stage Heat Rise °F(°C)	51 (28)	52(29)	53(29)	54(30)	55(31)	57(31)	58(32)	59(33)	61(34)	63(35)	
35 - 65°F Low Stage,35 - 65°F High Stage	Med-Low ³	Pink	CFM	1934	1900	1855	1815	1778	1737	1695	1656	1606	1528	
			BHP	0.59	0.61	0.62	0.64	0.65	0.67	0.68	0.70	0.70	0.68	
35 - 65°F Low Stage,35 - 65°F High Stage	Med-Low ³	Pink	Low Stage Heat Rise °F(°C)	NA	NA	NA	35 (20)	36(20)	37(20)	38(21)	40 (22)	42 (23)		
			High Stage Heat Rise °F(°C)	50(28)	50(28)	52(29)	53(29)	54(30)	55 (31)	57 (31)	58(32)	60(33)	63(35)	

Notes:
 1 Factory-shipped low stage cooling speed
 2 Factory-shipped high stage cooling speed
 3 Factory-shipped low stage gas heating speed
 4 Factory-shipped high stage gas heating speed
 Allowable High Stage Enhanced Dehumidification Cooling Speed
 "NA" = Not allowed for particular heating speed

DRY COIL AIR DELIVERY* - HORIZONTAL AND DOWNFLOW DISCHARGE - 208/230 VAC 3-PHASE MODELS (CONT)

UNIT-SIZE	HEATING RISE RANGE	MOTOR-SPEED	WIRE COLOR	EXTERNAL STATIC PRESSURE (IN. W.C.)														
				0.1	0.2	0.3	0.4	0.5	0.6	0.7	0.8	0.9	1					
42060	25 - 55°F Low Stage, 25 - 55°F High Stage	Low ³	Blue	CFM	694	624	533	460	383	328	---	---	---	---	---	---		
				BHP	0.05	0.05	0.06	0.07	0.07	0.08	---	---	---	---	---	---	---	
				Low Stage Heat Rise °F (°C)	41 (23)	46 (25)	54 (30)	NA	NA	NA	NA	NA	NA	NA	NA	NA	NA	NA
				High Stage Heat Rise °F (°C)	NA	NA	NA	NA	NA	NA	NA	NA	NA	NA	NA	NA	NA	NA
				CFM	1076	1026	972	918	872	827	771	714	666	611	566	521	477	433
				BHP	0.13	0.14	0.15	0.15	0.17	0.18	0.18	0.20	0.21	0.22	0.23	0.24	0.25	0.26
	25 - 55°F Low Stage, 25 - 55°F High Stage	Med-Low ¹	Pink	Red	CFM	1213	1169	1110	1065	1016	984	923	878	820	777	734	691	
					BHP	0.16	0.17	0.17	0.19	0.20	0.21	0.22	0.23	0.24	0.25	0.26	0.27	
					Low Stage Heat Rise °F (°C)	NA	NA	26 (14)	27 (15)	28 (16)	30 (16)	31 (17)	33 (18)	35 (19)	37 (20)	39 (21)	41 (23)	
					High Stage Heat Rise °F (°C)	37 (20)	38 (21)	40 (22)	42 (23)	44 (24)	46 (26)	48 (27)	51 (28)	54 (30)	57 (31)	60 (32)	63 (34)	
					CFM	1451	1415	1372	1327	1287	1249	1212	1168	1130	1094	1058	1022	
					BHP	0.29	0.30	0.31	0.32	0.33	0.35	0.36	0.37	0.38	0.39	0.40	0.41	
25 - 55°F Low Stage, 25 - 55°F High Stage	Med-High ²	Orange	Black	CFM	1633	1590	1552	1518	1483	1444	1406	1372	1340	1303	1266			
				BHP	0.41	0.43	0.44	0.45	0.47	0.48	0.49	0.50	0.51	0.52	0.53			
				Low Stage Heat Rise °F (°C)	NA	NA	NA	NA	NA	NA	NA	NA	NA	NA	NA	NA		
				High Stage Heat Rise °F (°C)	27 (15)	28 (16)	29 (16)	29 (16)	30 (17)	31 (17)	32 (18)	32 (18)	33 (18)	34 (19)	34 (19)			
				CFM	2097	1997	1897	1797	1697	1597	1497	1397	1297	1197	1097	997		
				BHP	0.12	0.11	0.10	0.11	0.12	0.13	0.13	0.14	0.15	0.16	0.17	0.18		

UNIT-SIZE	HEATING RISE RANGE	MOTOR-SPEED	WIRE COLOR	EXTERNAL STATIC PRESSURE (IN. W.C.)												
				0.1	0.2	0.3	0.4	0.5	0.6	0.7	0.8	0.9	1			
42090	35 - 65°F Low Stage, 35 - 65°F High Stage	Low ³	Blue	CFM	1097	971	823	747	669	636	558	513	456	412		
				BHP	0.12	0.11	0.10	0.11	0.12	0.13	0.13	0.14	0.15	0.16	0.17	
				Low Stage Heat Rise °F (°C)	39 (22)	44 (25)	52 (29)	58 (32)	64 (36)	NA	NA	NA	NA	NA	NA	
				High Stage Heat Rise °F (°C)	61 (34)	NA	NA	NA	NA	NA	NA	NA	NA	NA	NA	
				CFM	1076	1026	972	918	872	827	771	714	666	611	566	
				BHP	0.13	0.14	0.15	0.15	0.17	0.18	0.18	0.20	0.21	0.22	0.23	
	35 - 65°F Low Stage, 35 - 65°F High Stage	Med-Low ¹	Pink	Red	CFM	1251	1198	1149	1104	1066	1017	970	932	892	859	
					BHP	0.19	0.21	0.21	0.23	0.24	0.25	0.26	0.27	0.28	0.29	
					Low Stage Heat Rise °F (°C)	NA	36 (20)	37 (21)	39 (22)	40 (22)	42 (23)	44 (25)	46 (26)	48 (27)	51 (28)	
					High Stage Heat Rise °F (°C)	54 (30)	56 (31)	59 (33)	61 (34)	63 (35)	NA	NA	NA	NA	NA	
					CFM	1451	1415	1372	1327	1287	1249	1212	1168	1130	1094	1058
					BHP	0.29	0.30	0.31	0.32	0.33	0.35	0.36	0.37	0.38	0.39	0.40
35 - 65°F Low Stage, 35 - 65°F High Stage	Med-High ²	Orange	Black	CFM	1633	1590	1552	1518	1483	1444	1406	1372	1340	1303		
				BHP	0.41	0.43	0.44	0.45	0.47	0.48	0.49	0.50	0.51	0.52		
				Low Stage Heat Rise °F (°C)	NA	NA	NA	NA	NA	NA	NA	NA	NA	NA	NA	
				High Stage Heat Rise °F (°C)	41 (23)	42 (24)	43 (24)	44 (25)	45 (25)	47 (26)	48 (27)	49 (27)	50 (28)	52 (29)		
				CFM	2097	1997	1897	1797	1697	1597	1497	1397	1297	1197	1097	
				BHP	0.12	0.11	0.10	0.11	0.12	0.13	0.13	0.14	0.15	0.16	0.17	

See notes on page 33.

DRY COIL AIR DELIVERY* - HORIZONTAL AND DOWNFLOW DISCHARGE - 208/230 VAC 3-PHASE MODELS (CONT)

UNIT-SIZE	HEATING RISE RANGE	MOTOR-SPEED	WIRE COLOR	HEATING RISE RANGE	EXTERNAL STATIC PRESSURE (IN. W.C.)											
					0.1	0.2	0.3	0.4	0.5	0.6	0.7	0.8	0.9	1		
48090	35 - 65°F Low Stage, 35 - 65°F High Stage	Med-Low ¹	Pink	CFM	1067	904	703	587	501	449	380	340	---	---		
				BHP	0.12	0.10	0.09	0.09	0.10	0.11	0.12	---	---	---		
				Low Stage Heat Rise °F (°C)	40 (22)	48 (26)	61 (34)	NA	NA	NA	NA	NA	NA	NA	NA	
				High Stage Heat Rise °F (°C)	63 (35)	NA	NA	NA	NA	NA	NA	NA	NA	NA	NA	
				CFM	1271	1229	1177	1121	1066	1027	974	942	887	839	829	
				BHP	0.19	0.20	0.21	0.23	0.24	0.25	0.26	0.27	0.28	0.29	0.29	
	48090	35 - 65°F Low Stage, 35 - 65°F High Stage	Med-High ²	Orange	CFM	1340	1299	1240	1191	1139	1091	1050	1001	952	895	
					BHP	0.22	0.23	0.24	0.25	0.26	0.28	0.29	0.30	0.31	0.32	
					Low Stage Heat Rise °F (°C)	NA	NA	35 (19)	36 (20)	38 (21)	41 (23)	43 (24)	45 (25)	48 (27)	48 (27)	
					High Stage Heat Rise °F (°C)	50 (28)	52 (29)	54 (30)	57 (31)	59 (33)	62 (34)	64 (36)	NA	NA	NA	
					CFM	1686	1650	1617	1576	1544	1503	1468	1433	1393	1356	1356
					BHP	0.42	0.44	0.45	0.46	0.48	0.49	0.51	0.52	0.53	0.55	0.55
48115	30 - 60°F Low Stage, 30 - 60°F High Stage	High	Black	CFM	1854	1837	1781	1784	1720	1698	1655	1625	1578	1532		
				BHP	0.56	0.57	0.60	0.59	0.62	0.63	0.64	0.66	0.67	0.67		
				Low Stage Heat Rise °F (°C)	NA	NA	NA	NA	NA	NA	NA	NA	NA	NA		
				High Stage Heat Rise °F (°C)	36 (20)	37 (20)	38 (21)	38 (21)	39 (22)	40 (22)	41 (23)	41 (23)	43 (24)	44 (24)		
				CFM	1686	1650	1617	1576	1544	1503	1468	1433	1393	1356	1356	
				BHP	0.42	0.44	0.45	0.46	0.48	0.49	0.51	0.52	0.53	0.55	0.55	
	48115	30 - 60°F Low Stage, 30 - 60°F High Stage	Med-High ²	Red	CFM	1854	1837	1781	1784	1720	1698	1655	1625	1578	1532	
					BHP	0.56	0.57	0.60	0.59	0.62	0.63	0.64	0.66	0.67	0.67	
					Low Stage Heat Rise °F (°C)	NA	NA	NA	NA	NA	NA	NA	NA	NA	NA	
					High Stage Heat Rise °F (°C)	36 (20)	37 (20)	38 (21)	38 (21)	39 (22)	40 (22)	41 (23)	41 (23)	43 (24)	44 (24)	
					CFM	1686	1650	1617	1576	1544	1503	1468	1433	1393	1356	1356
					BHP	0.42	0.44	0.45	0.46	0.48	0.49	0.51	0.52	0.53	0.55	0.55

UNIT-SIZE	HEATING RISE RANGE	MOTOR-SPEED	WIRE COLOR	HEATING RISE RANGE	EXTERNAL STATIC PRESSURE (IN. W.C.)										
					0.1	0.2	0.3	0.4	0.5	0.6	0.7	0.8	0.9	1	
48115	30 - 60°F Low Stage, 30 - 60°F High Stage	Low ¹	Blue	CFM	1271	1229	1177	1121	1066	1027	974	942	887	839	
				BHP	0.19	0.20	0.21	0.23	0.24	0.25	0.26	0.27	0.28	0.29	
				Low Stage Heat Rise °F (°C)	44 (24)	45 (25)	47 (26)	50 (28)	52 (29)	54 (30)	57 (32)	59 (33)	NA	NA	
				High Stage Heat Rise °F (°C)	NA	NA	NA	NA	NA	NA	NA	NA	NA	NA	
				CFM	1340	1299	1240	1191	1139	1091	1050	1001	952	895	
				BHP	0.22	0.23	0.24	0.25	0.26	0.28	0.29	0.30	0.31	0.32	
	48115	30 - 60°F Low Stage, 30 - 60°F High Stage	Med-Low ³	Pink	CFM	1686	1650	1617	1576	1544	1503	1468	1433	1393	1356
					BHP	0.42	0.44	0.45	0.46	0.48	0.49	0.51	0.52	0.53	0.55
					Low Stage Heat Rise °F (°C)	33 (18)	34 (19)	35 (19)	35 (20)	36 (20)	37 (21)	38 (21)	39 (22)	40 (22)	41 (23)
					High Stage Heat Rise °F (°C)	52 (29)	53 (29)	54 (30)	55 (31)	56 (31)	58 (32)	59 (33)	NA	NA	NA
					CFM	1854	1837	1781	1784	1720	1698	1655	1625	1578	1532
					BHP	0.56	0.57	0.60	0.59	0.62	0.63	0.64	0.66	0.67	0.67
48115	30 - 60°F Low Stage, 30 - 60°F High Stage	Med-High	Orange	CFM	1934	1900	1855	1815	1778	1737	1698	1656	1606	1528	
				BHP	0.59	0.61	0.62	0.64	0.65	0.67	0.68	0.70	0.70		
				Low Stage Heat Rise °F (°C)	30 (17)	30 (17)	31 (17)	31 (17)	32 (18)	33 (18)	34 (19)	34 (19)	35 (20)	36 (20)	
				High Stage Heat Rise °F (°C)	47 (26)	47 (26)	49 (27)	49 (27)	51 (28)	51 (28)	53 (29)	53 (30)	55 (31)	57 (32)	
				CFM	1934	1900	1855	1815	1778	1737	1698	1656	1606	1528	
				BHP	0.59	0.61	0.62	0.64	0.65	0.67	0.68	0.70	0.70		
48115	30 - 60°F Low Stage, 30 - 60°F High Stage	High ⁴	Black	CFM	1934	1900	1855	1815	1778	1737	1698	1656	1606	1528	
				BHP	0.59	0.61	0.62	0.64	0.65	0.67	0.68	0.70	0.70		
				Low Stage Heat Rise °F (°C)	NA	NA	30 (17)	31 (17)	31 (17)	32 (18)	33 (18)	34 (19)	35 (19)	37 (20)	
				High Stage Heat Rise °F (°C)	45 (25)	46 (25)	47 (26)	48 (27)	49 (27)	50 (28)	51 (28)	52 (29)	54 (30)	57 (32)	
				CFM	1934	1900	1855	1815	1778	1737	1698	1656	1606	1528	
				BHP	0.59	0.61	0.62	0.64	0.65	0.67	0.68	0.70	0.70		

See notes on page 33.

DRY COIL AIR DELIVERY* - HORIZONTAL AND DOWNFLOW DISCHARGE - 208/230 VAC MODELS (CONT)

UNIT-SIZE	HEATING RISE RANGE	MOTOR-SPEED	WIRE COLOR	EXTERNAL STATIC PRESSURE (IN. W.C.)											
				0.1	0.2	0.3	0.4	0.5	0.6	0.7	0.8	0.9	1		
48130	35 - 65°F Low Stage, 35 - 65°F High Stage	Low ¹	Blue	CFM	1271	1229	1177	1121	1066	1027	974	942	887	839	
				BHP	0.19	0.20	0.21	0.23	0.24	0.25	0.26	0.27	0.28	0.29	
				Low Stage Heat Rise °F (°C)	49 (27)	51 (28)	53 (30)	56 (31)	59 (33)	61 (34)	64 (36)	NA	NA	NA	NA
				High Stage Heat Rise °F (°C)	NA	NA	NA	NA	NA	NA	NA	NA	NA	NA	NA
				CFM	1340	1299	1240	1191	1139	1091	1050	1001	952	895	839
				BHP	0.22	0.23	0.24	0.25	0.26	0.28	0.31	0.30	0.31	0.32	0.32
	Med-Low ³	Pink	Med-Low ³	Pink	Low Stage Heat Rise °F (°C)	47 (26)	48 (27)	51 (28)	53 (29)	55 (31)	57 (32)	60 (33)	63 (35)	NA	
					High Stage Heat Rise °F (°C)	NA	NA	NA	NA	NA	NA	NA	NA	NA	NA
					CFM	1686	1650	1617	1576	1544	1503	1468	1433	1393	1356
					BHP	0.42	0.44	0.45	0.46	0.48	0.49	0.51	0.52	0.53	0.55
					Low Stage Heat Rise °F (°C)	37 (21)	38 (21)	39 (22)	40 (22)	41 (23)	42 (23)	43 (24)	44 (24)	45 (25)	46 (26)
					High Stage Heat Rise °F (°C)	57 (32)	58 (32)	59 (33)	61 (34)	62 (35)	64 (35)	65(36)	NA	NA	NA
60090	35 - 65°F Low Stage, 35 - 65°F High Stage	Med-High	Orange	CFM	1854	1837	1781	1784	1720	1698	1655	1625	1578	1532	
				BHP	0.56	0.57	0.60	0.59	0.62	0.63	0.64	0.66	0.67	0.67	
				Low Stage Heat Rise °F (°C)	NA	NA	35 (20)	35 (20)	36 (20)	37 (20)	38 (21)	39 (21)	40 (22)	41 (23)	
				High Stage Heat Rise °F (°C)	52 (29)	52 (29)	54 (30)	54 (30)	56 (31)	56 (31)	58 (32)	59 (33)	61 (34)	63 (35)	
				CFM	1934	1900	1855	1815	1778	1737	1695	1656	1606	1528	
				BHP	0.59	0.61	0.62	0.64	0.65	0.67	0.68	0.70	0.70	0.68	
	High ⁴	Black	High ⁴	Black	Low Stage Heat Rise °F (°C)	NA	NA	NA	NA	35 (20)	36 (20)	37 (21)	38 (21)	39 (22)	
					High Stage Heat Rise °F (°C)	50 (28)	50 (28)	52 (29)	53 (29)	54 (30)	55 (31)	57 (31)	58 (32)	60 (33)	
					CFM	1340	1299	1240	1191	1139	1091	1050	1001	952	895
					BHP	0.22	0.23	0.24	0.25	0.26	0.28	0.29	0.30	0.31	0.32
					Low Stage Heat Rise °F (°C)	NA	NA	35 (19)	36 (20)	38 (21)	39 (22)	41 (23)	43 (24)	45 (25)	48 (27)
					High Stage Heat Rise °F (°C)	50 (28)	52 (29)	54 (30)	57 (31)	59 (33)	62 (34)	64 (36)	NA	NA	NA
60090	35 - 65°F Low Stage, 35 - 65°F High Stage	Med-High ²	Orange	CFM	1878	1844	1805	1762	1731	1693	1655	1616	1570	1532	
				BHP	0.50	0.52	0.53	0.54	0.56	0.57	0.59	0.60	0.64	0.63	
				Low Stage Heat Rise °F (°C)	NA	NA	NA	NA	NA	NA	NA	NA	NA	NA	
				High Stage Heat Rise °F (°C)	36 (20)	37 (20)	37 (21)	38 (21)	39 (22)	40 (22)	41 (23)	42 (23)	43 (24)	44 (24)	
				CFM	2020	1990	1956	1912	1872	1842	1802	1760	1719	1643	
				BHP	0.62	0.63	0.66	0.67	0.69	0.70	0.71	0.73	0.74	0.72	
	High	Black	High	Black	Low Stage Heat Rise °F (°C)	NA	NA	NA	NA	NA	NA	NA	NA	NA	
					High Stage Heat Rise °F (°C)	NA	NA	NA	35 (20)	36 (20)	37 (20)	37 (21)	38 (21)	39 (22)	
					CFM	1340	1299	1240	1191	1139	1091	1050	1001	952	895
					BHP	0.22	0.23	0.24	0.25	0.26	0.28	0.29	0.30	0.31	0.32
					Low Stage Heat Rise °F (°C)	NA	NA	35 (19)	36 (20)	38 (21)	39 (22)	41 (23)	43 (24)	45 (25)	48 (27)
					High Stage Heat Rise °F (°C)	50 (28)	52 (29)	54 (30)	57 (31)	59 (33)	62 (34)	64 (36)	NA	NA	NA

UNIT-SIZE	HEATING RISE RANGE	MOTOR-SPEED	WIRE COLOR	EXTERNAL STATIC PRESSURE (IN. W.C.)											
				0.1	0.2	0.3	0.4	0.5	0.6	0.7	0.8	0.9	1		
48130	35 - 65°F Low Stage, 35 - 65°F High Stage	Low ¹	Blue	CFM	1067	904	703	587	501	449	380	340	---	---	
				BHP	0.12	0.10	0.09	0.09	0.09	0.10	0.11	0.12	---	---	
				Low Stage Heat Rise °F (°C)	40 (22)	48 (26)	61 (34)	NA	NA	NA	NA	NA	NA	NA	NA
				High Stage Heat Rise °F (°C)	63 (35)	NA	NA	NA	NA	NA	NA	NA	NA	NA	NA
				CFM	1271	1229	1177	1121	1066	1027	974	942	887	839	
				BHP	0.19	0.20	0.21	0.23	0.24	0.25	0.26	0.27	0.28	0.29	
	Med-Low ¹	Pink	Med-Low ¹	Pink	Low Stage Heat Rise °F (°C)	NA	35 (19)	36 (20)	38 (21)	40 (22)	42 (23)	44 (25)	46 (25)	48 (27)	
					High Stage Heat Rise °F (°C)	53 (29)	55 (30)	57 (32)	60 (33)	63 (35)	NA	NA	NA	NA	
					CFM	1340	1299	1240	1191	1139	1091	1050	1001	952	895
					BHP	0.22	0.23	0.24	0.25	0.26	0.28	0.29	0.30	0.31	0.32
					Low Stage Heat Rise °F (°C)	NA	NA	35 (19)	36 (20)	38 (21)	39 (22)	41 (23)	43 (24)	45 (25)	48 (27)
					High Stage Heat Rise °F (°C)	50 (28)	52 (29)	54 (30)	57 (31)	59 (33)	62 (34)	64 (36)	NA	NA	NA
60090	35 - 65°F Low Stage, 35 - 65°F High Stage	Med-High ²	Orange	CFM	1878	1844	1805	1762	1731	1693	1655	1616	1570	1532	
				BHP	0.50	0.52	0.53	0.54	0.56	0.57	0.59	0.60	0.64	0.63	
				Low Stage Heat Rise °F (°C)	NA	NA	NA	NA	NA	NA	NA	NA	NA	NA	
				High Stage Heat Rise °F (°C)	36 (20)	37 (20)	37 (21)	38 (21)	39 (22)	40 (22)	41 (23)	42 (23)	43 (24)	44 (24)	
				CFM	2020	1990	1956	1912	1872	1842	1802	1760	1719	1643	
				BHP	0.62	0.63	0.66	0.67	0.69	0.70	0.71	0.73	0.74	0.72	
	High	Black	High	Black	Low Stage Heat Rise °F (°C)	NA	NA	NA	NA	NA	NA	NA	NA	NA	
					High Stage Heat Rise °F (°C)	NA	NA	NA	35 (20)	36 (20)	37 (20)	37 (21)	38 (21)	39 (22)	
					CFM	1340	1299	1240	1191	1139	1091	1050	1001	952	895
					BHP	0.22	0.23	0.24	0.25	0.26	0.28	0.29	0.30	0.31	0.32
					Low Stage Heat Rise °F (°C)	NA	NA	35 (19)	36 (20)	38 (21)	39 (22)	41 (23)	43 (24)	45 (25)	48 (27)
					High Stage Heat Rise °F (°C)	50 (28)	52 (29)	54 (30)	57 (31)	59 (33)	62 (34)	64 (36)	NA	NA	NA

See notes on page 33.

DRY COIL AIR DELIVERY* - HORIZONTAL AND DOWNFLOW DISCHARGE - 208/230 VAC 3-PHASE MODELS (CONT)

UNIT-SIZE	HEATING RISE RANGE	MOTOR-SPEED	WIRE COLOR	EXTERNAL STATIC PRESSURE (IN. W.C.)										
				0.1	0.2	0.3	0.4	0.5	0.6	0.7	0.8	0.9	1	
60115	30 - 60°F Low Stage, 30 - 60°F High Stage	Med-Low ³	Pink	CFM	1271	1229	1177	1121	1066	1027	974	942	887	839
				BHP	0.19	0.20	0.21	0.23	0.24	0.25	0.26	0.27	0.28	0.29
	Low Stage Heat Rise °F (°C)	High Stage Heat Rise °F (°C)	NA	44 (24)	45 (25)	47 (26)	50 (28)	52 (29)	54 (30)	57 (32)	59 (33)	NA	NA	NA
			NA	NA	NA	NA	NA	NA	NA	NA	NA	NA	NA	NA
	Low Stage Heat Rise °F (°C)	High Stage Heat Rise °F (°C)	CFM	1340	1299	1240	1191	1139	1091	1050	1001	952	895	
			BHP	0.22	0.23	0.24	0.25	0.26	0.28	0.29	0.30	0.31	0.32	
	Low Stage Heat Rise °F (°C)	High Stage Heat Rise °F (°C)	NA	42 (23)	43 (24)	45 (25)	47 (26)	49 (27)	51 (28)	53 (30)	56 (31)	59 (33)	NA	NA
			NA	NA	NA	NA	NA	NA	NA	NA	NA	NA	NA	NA
	30 - 60°F Low Stage, 30 - 60°F High Stage	Medium	Red	CFM	1686	1650	1617	1576	1544	1503	1468	1433	1393	1356
				BHP	0.42	0.44	0.45	0.46	0.48	0.49	0.51	0.52	0.53	0.55
Low Stage Heat Rise °F (°C)	High Stage Heat Rise °F (°C)	NA	33 (18)	34 (19)	35 (19)	35 (20)	36 (20)	37 (21)	38 (21)	39 (22)	40 (22)	41 (23)		
		NA	52 (29)	53 (29)	54 (30)	55 (31)	56 (31)	58 (32)	59 (33)	NA	NA	NA		
Low Stage Heat Rise °F (°C)	High Stage Heat Rise °F (°C)	CFM	1878	1844	1805	1762	1731	1693	1655	1616	1570	1532		
		BHP	0.50	0.52	0.53	0.54	0.56	0.57	0.59	0.60	0.64	0.63		
Low Stage Heat Rise °F (°C)	High Stage Heat Rise °F (°C)	NA	30 (17)	31 (17)	31 (17)	32 (18)	32 (18)	33 (18)	34 (19)	35 (19)	36 (20)	36 (20)		
		NA	46 (26)	47 (26)	48 (27)	49 (27)	50 (28)	51 (29)	53 (29)	54 (30)	55 (31)	57 (32)		
Low Stage Heat Rise °F (°C)	High Stage Heat Rise °F (°C)	CFM	1934	1900	1855	1815	1778	1737	1695	1656	1606	1528		
		BHP	0.59	0.61	0.62	0.64	0.65	0.67	0.68	0.70	0.70	0.68		
Low Stage Heat Rise °F (°C)	High Stage Heat Rise °F (°C)	NA	NA	NA	30 (17)	31 (17)	31 (17)	32 (18)	33 (18)	34 (19)	35 (19)	37 (20)		
		NA	45 (25)	46 (25)	47 (26)	48 (27)	49 (27)	50 (28)	51 (28)	52 (29)	54 (30)	57 (32)		

UNIT-SIZE	HEATING RISE RANGE	MOTOR-SPEED	WIRE COLOR	EXTERNAL STATIC PRESSURE (IN. W.C.)										
				0.1	0.2	0.3	0.4	0.5	0.6	0.7	0.8	0.9	1	
60130	35 - 65°F Low Stage, 35 - 65°F High Stage	Med-Low ³	Pink	CFM	1271	1229	1177	1121	1066	1027	974	942	887	839
				BHP	0.19	0.20	0.21	0.23	0.24	0.25	0.26	0.27	0.28	0.29
	Low Stage Heat Rise °F (°C)	High Stage Heat Rise °F (°C)	NA	49 (27)	51 (28)	53 (30)	56 (31)	59 (33)	61 (34)	64 (36)	NA	NA	NA	
			NA	NA	NA	NA	NA	NA	NA	NA	NA	NA	NA	
	Low Stage Heat Rise °F (°C)	High Stage Heat Rise °F (°C)	CFM	1340	1299	1240	1191	1139	1091	1050	1001	952	895	
			BHP	0.22	0.23	0.24	0.25	0.26	0.28	0.29	0.30	0.31	0.32	
	Low Stage Heat Rise °F (°C)	High Stage Heat Rise °F (°C)	NA	47 (26)	48 (27)	51 (28)	53 (29)	55 (31)	57 (32)	60 (33)	63 (35)	NA	NA	
			NA	NA	NA	NA	NA	NA	NA	NA	NA	NA	NA	
	35 - 65°F Low Stage, 35 - 65°F High Stage	Medium	Red	CFM	1686	1650	1617	1576	1544	1503	1468	1433	1393	1356
				BHP	0.42	0.44	0.45	0.46	0.48	0.49	0.51	0.52	0.53	0.55
Low Stage Heat Rise °F (°C)	High Stage Heat Rise °F (°C)	NA	37 (21)	38 (21)	39 (22)	40 (22)	41 (23)	42 (23)	43 (24)	44 (24)	45 (25)	46 (26)		
		NA	57 (32)	58 (32)	59 (33)	61 (34)	62 (35)	64 (35)	65 (36)	NA	NA	NA		
Low Stage Heat Rise °F (°C)	High Stage Heat Rise °F (°C)	CFM	1878	1844	1805	1762	1731	1693	1655	1616	1570	1532		
		BHP	0.50	0.52	0.53	0.54	0.56	0.57	0.59	0.60	0.64	0.63		
Low Stage Heat Rise °F (°C)	High Stage Heat Rise °F (°C)	NA	NA	NA	35 (19)	36 (20)	37 (21)	38 (21)	39 (22)	40 (22)	41 (23)			
		NA	51 (28)	52 (29)	53 (30)	54 (30)	55 (31)	57 (31)	59 (33)	61 (34)	63 (35)			
Low Stage Heat Rise °F (°C)	High Stage Heat Rise °F (°C)	CFM	1934	1900	1855	1815	1778	1737	1695	1656	1606	1528		
		BHP	0.59	0.61	0.62	0.64	0.65	0.67	0.68	0.70	0.70	0.68		
Low Stage Heat Rise °F (°C)	High Stage Heat Rise °F (°C)	NA	NA	NA	35 (19)	35 (20)	36 (20)	37 (21)	38 (21)	39 (22)	41 (23)			
		NA	50 (28)	50 (28)	52 (29)	53 (29)	54 (30)	55 (31)	57 (31)	58 (32)	60 (33)			

Notes:

- 1 Factory-shipped low stage cooling speed
 - 2 Factory-shipped high stage cooling speed
 - 3 Factory-shipped low stage gas heating speed
 - 4 Factory-shipped high stage gas heating speed
- * Allowable High Stage Enhanced Dehumidification Cooling Speed
- "NA" = Not allowed for particular heating speed

Filter Pressure Drop Table (IN. W.C.)

Filter Size in. (mm)	CoolingTons	Standard CFM (SCFM)																
		600	700	800	900	1000	1100	1200	1300	1400	1500	1600	1700	1800	1900	2000	2100	2200
600-1400 CFM1 2x20x1 + 12x20x1 (305 x508x25 + 305x508x25)	2.0,2.5,	0.03	0.04	0.05	0.06	0.06	0.07	0.07	0.08	0.08	-	-	-	-	-	-	-	-
1200-1800 CFM1 6x24x1 + 14x24x1 (406 x610x25 + 356x610x25)	3.03,5,4,0	-	-	-	-	0.04	0.05	0.06	0.07	0.08	0.09	0.10	0.11	0.12	0.12	0.13	-	-
1500-2200 CFM1 6x24x1 + 18x24x1 (406 x610x25 + 457x356x25)	5.0	-	-	-	-	-	-	-	-	-	0.04	0.06	0.08	0.10	0.11	0.13	0.14	0.15

Wet Coil Pressure Drop (IN. W.C.)

UnitSize	Standard CFM (SCFM)																	
	600	700	800	900	1000	1100	1200	1300	1400	1500	1600	1700	1800	1900	2000	2100	2200	
24	0.03	0.04	0.04	0.05	0.06													
30				0.05	0.06	0.07	0.08	0.11										
36				0.06	0.06	0.09	0.10	0.11	0.14									
42					0.05	0.05	0.06	0.07	0.08	0.08	0.09	0.09	0.11					
48							0.04	0.06	0.09	0.10	0.10	0.11	0.12	0.13	0.14			
60									0.06	0.07	0.07	0.08	0.08	0.09	0.10	0.12	0.12	0.13

Economizer with 1-in. Filter Pressure Drop (IN. W.C.)

Filter Size in. (mm)	CoolingTons	Standard CFM (SCFM)																
		600	700	800	900	1000	1100	1200	1300	1400	1500	1600	1700	1800	1900	2000	2100	2200
600-1400 CFM 12x20x1 + 12x20x1 (305x508x25+305x508x25)	2.0,2.5,	-	-	0.08	0.09	0.10	0.11	0.11	0.13	0.14	-	-	-	-	-	-	-	-
1200-1800 CFM 16x24x1 + 14x24x1 (406x610x25+356x610x25)	3.03,5,4,0	-	-	-	-	-	0.09	0.09	0.10	0.12	0.13	0.15	0.17	0.17	0.19	0.21	-	-
1500-2200 CFM 16x24x1 + 18x24x1 (406x610x25+457x356x25)	5.0	-	-	-	-	-	-	-	-	-	0.15	0.17	0.18	0.20	0.21	0.22	0.23	0.23

TYPICAL PIPING AND WIRING

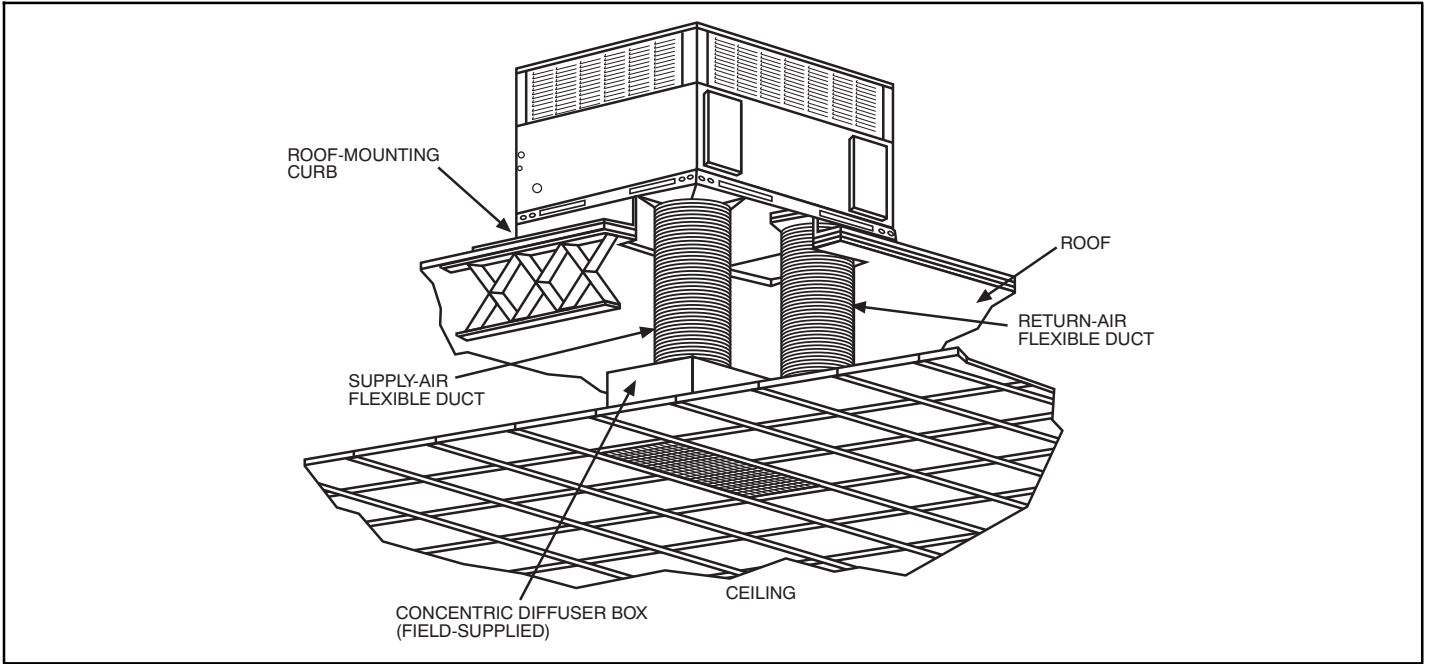

A09233

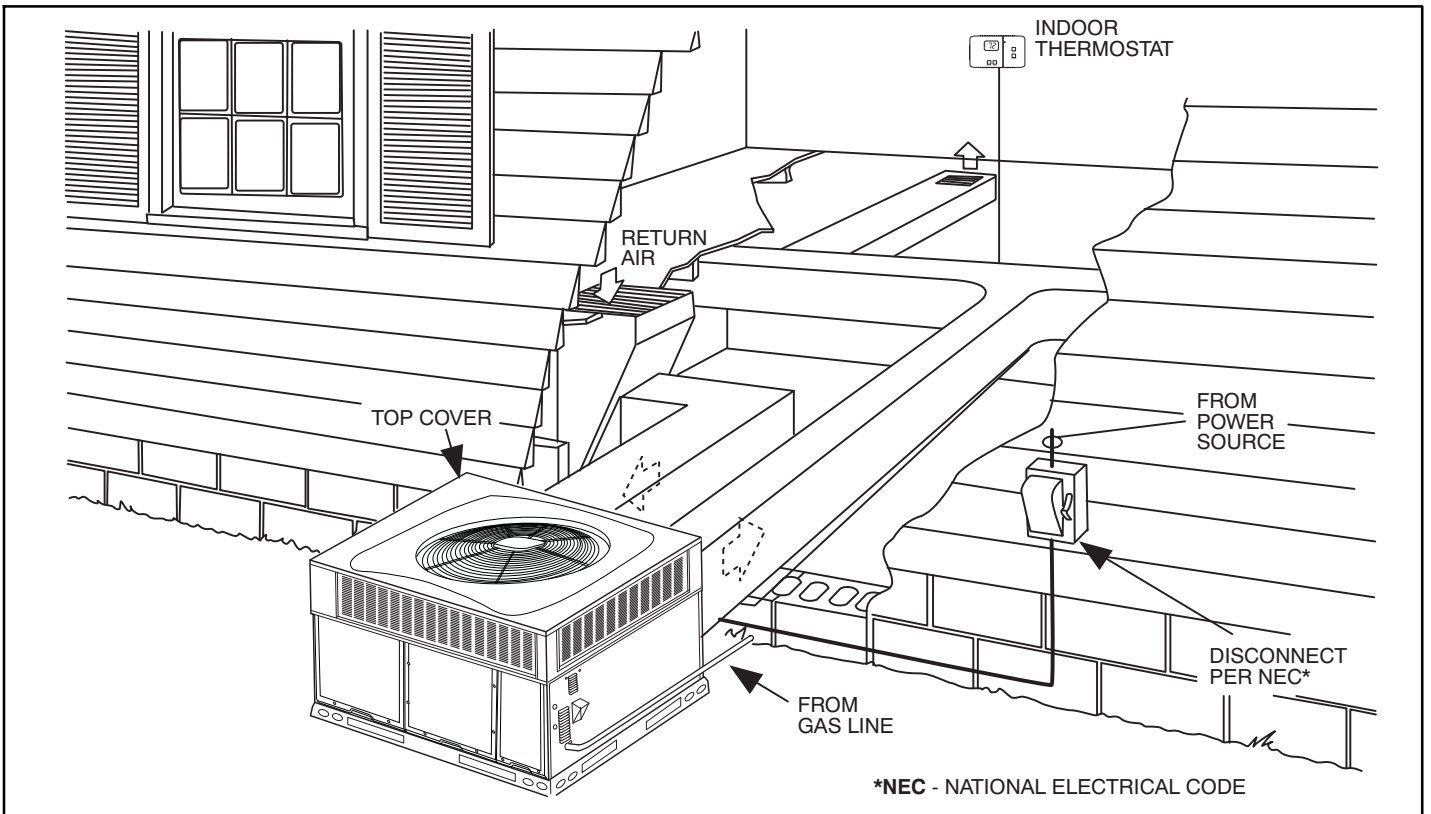

A09234

APPLICATION DATA

Condensate trap — A 2-in. (50.8 mm) condensate trap must be field supplied.

Ductwork — Secure downflow discharge ductwork to roof curb. For horizontal discharge applications, attach ductwork to unit with flanges.

To convert a unit to downflow discharge — Units are equipped with factory-installed inserts in the down-flow openings. Removal of the inserts is similar to removing an electrical knock-out. Use the duct cover to seal the horizontal discharge openings in the unit. Units installed in horizontal discharge orientation do not require duct covers.

Airflow — Units are draw-thru in the cooling mode and blow-thru in the heating mode.

Maximum cooling airflow — To minimize the possibility of condensate blow-off from the evaporator, airflow through the units should not exceed 450 cfm per ton.

Minimum cooling airflow — Minimum cooling airflow is 350 cfm per ton.

Minimum ambient cooling operation temperature — All standard units have a minimum ambient operating temperature of 40°F (4°C). With accessory low ambient temperature kit, units can operate at temperatures down to 0°F (-17°C).

Minimum temperature — Air entering the heat exchanger in heating mode must be a minimum of 55°F (13°C) continuous and a maximum of 80°F (27°C) continuous.

ELECTRICAL DATA

UNIT	NOMINAL	VOLTAGE RANGE		COMPRESSOR		OFM	IFM	IDM	POWER SUPPLY	
		MIN	MAX	RLA	LRA	FLA	FLA	FLA	MCA	MOCP
2404030 2406030	208/230-1-60	197	253	11.7	58.3	0.7	4.1	.27	19.4	30
3004030 3006030	208/230-1-60	197	253	13.1	73.0	1.2	4.1	.27	21.7	30
3004050 3006050	208/230-3-60	197	253	8.7	58.0	1.2	4.1	.21	16.2	20
3606030 3609030	208/230-1-60	197	253	15.3	83.0	1.2	6.0	.27	26.3	40
3606050 3609050	208/230-3-60	197	253	11.6	73.0	1.2	6.0	.21	21.7	30
4206030 4209030	208/230-1-60	197	253	17.9	96.0	1.2	6.0	.27	29.6	45
4206050 4209050	208/230-3-60	197	253	14.2	88.0	1.2	6.0	.21	25.0	35
4809030 4811530 4813030	208/230-1-60	197	253	21.2	104.0	1.2	7.6	.27	35.3	50
4809050 4811550 4813050	208/230-3-60	197	253	14.0	83.1	1.2	7.6	.21 .50 .50	26.3	40
6009030 6011530 6013030	208/230-1-60	197	253	28.8	152.9	1.2	7.6	.27	44.8	60
6009050 6011550 6013050	208/230-3-60	197	253	16.2	110.0	1.2	7.6	.21 .50 .50	29.1	40

LEGEND

FLA - Full Load Amps
 IDM - Inducer Motor
 IFM - Indoor Fan Motor
 LRA - Locked Rotor Amps
 MCA - Minimum Circuit Amps
 MOCP - Maximum Over Current Protection
 OFM - Outdoor Fan Motor
 RLA - Rated Load Amps

NOTES:

- In compliance with NEC (National Electrical Code) requirements for multimotor and combination load equipment (refer to NEC Articles 430 and 440), the overcurrent protective device for the unit shall be Power Supply fuse or circuit breaker.
- Minimum wire size is based on 60 C copper wire. If other than 60 C wire is used, or if length exceeds wire length in table, determine size from NEC.
- Unbalanced 3-Phase Supply Voltage
Never operate a motor where a phase imbalance in supply voltage is greater than 2%. Use the following formula to determine the percentage of voltage imbalance

$$\% \text{ Voltage imbalance} = 100 \times \frac{\text{max voltage deviation from average voltage}}{\text{average voltage}}$$

EXAMPLE: Supply voltage is 230-3-60.

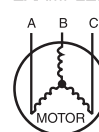

AB = 228 v
 BC = 231 v
 AC = 227 v

$$\begin{aligned} \text{Average Voltage} &= \frac{228 + 231 + 227}{3} \\ &= \frac{686}{3} \\ &= 229 \end{aligned}$$

Determine maximum deviation from average voltage.

(AB) 229 - 228 = 1 v
 (BC) 231 - 229 = 2 v
 (AC) 229 - 227 = 2 v

Maximum deviation is 2 v.

Determine percent of voltage imbalance

$$\begin{aligned} \% \text{ Voltage Imbalance} &= 100 \times \frac{2}{229} \\ &= 0.8\% \end{aligned}$$

This amount of phase imbalance is satisfactory as it is below the maximum allowable 2%.

IMPORTANT: If the supply voltage phase imbalance is more than 2%, contact your local electric utility company immediately.

LADDER WIRING SCHEMATIC 208/230-1-60

LADDER WIRING DIAGRAM

WARNING: DANGER: ELECTRICAL SHOCK HAZARD DISCONNECT POWER BEFORE SERVICING

LEGEND		
	FIELD SPLICE	EQUIP
	TERMINAL (MARKED)	FS
	TERMINAL (UNMARKED)	GND
	SPLICE	HPS
	SPLICE (MARKED)	IDM
	FACTORY LO VOLTAGE	IFM
	FIELD CONTROL WIRING	IGC
	FIELD POWER WIRING	LGPS
	ACCESSORY OR OPTIONAL WIRING	LPS
	FACTORY HI VOLTAGE	LS1
C	CONTACTOR	LS2
CAP1	CAPACITOR, COMP	MGV
CAP2	CAPACITOR, INDUCER	OFM
CCH	CRANKCASE HEATER	OT
COMP	COMPRESSOR MOTOR	PL1
		PL2
		RS
		SOL
		TRAN
		T-STAT
		EQUIPMENT
		FLAME SENSOR
		GROUND
		HIGH PRESSURE SWITCH
		IGNITOR
		INDUCED DRAFT MOTOR
		INDOOR FAN MOTOR
		INTERGRATED GAS UNIT CONTROLLER
		LOW GAS PRESSURE SWITCH (WHEN USED)
		LOW PRESSURE SWITCH
		PRIMARY LIMIT SWITCH
		SECONDARY LIMIT SWITCH
		MAIN GAS VALVE
		OUTDOOR FAN MOTOR
		QUADRUPLE TERMINAL
		IGC TO INDUCER MOTOR PLUG
		INDUCER MOTOR PLUG
		ROLLOUT SWITCH
		COMPRESSOR SOLENOID
		TRANSFORMER
		THERMOSTAT

1Ø UNIT COMPONENT ARRANGEMENT

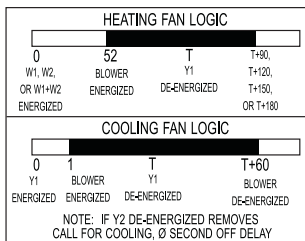
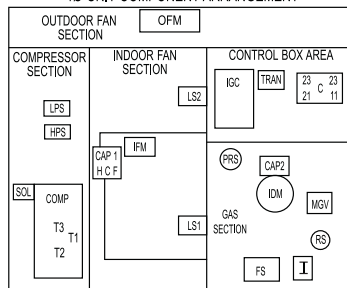

NOTES:

- IF ANY OF THE ORIGINAL WIRES FURNISHED ARE REPLACED THEY MUST BE REPLACED WITH THE SAME WIRE OR ITS EQUIVALENT.
- SEE PRE-SALE LITERATURE FOR THERMOSTATS.
- USE 75 DEGREES C COPPER CONDUCTORS FOR FIELD INSTALLATION.
- REFER TO INSTALLATION INSTRUCTIONS FOR CORRECT SPEED SELECTION FOR IFM.
- SEE INSTALLATION INSTRUCTIONS FOR PROPER HEATING AND COOLING CONNECTIONS FOR YOUR UNIT.
- ON SOME MODELS LS1 AND LS2 ARE WIRED IN SERIES. ON OTHER MODELS ONLY LS1 IS USED.
- THIS FUSE IS MANUFACTURED BY LITTLE FUSE, P/N 257003.
- DO NOT DISCONNECT PLUG UNDER LOAD.
- N.E.C. CLASS 2, 24V.

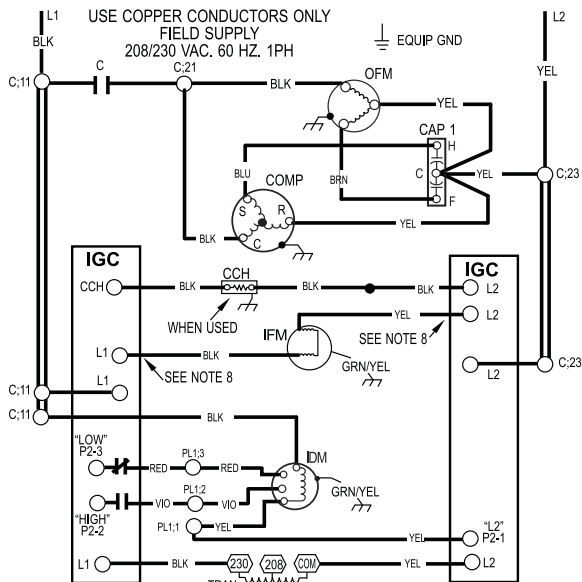

T-STAT

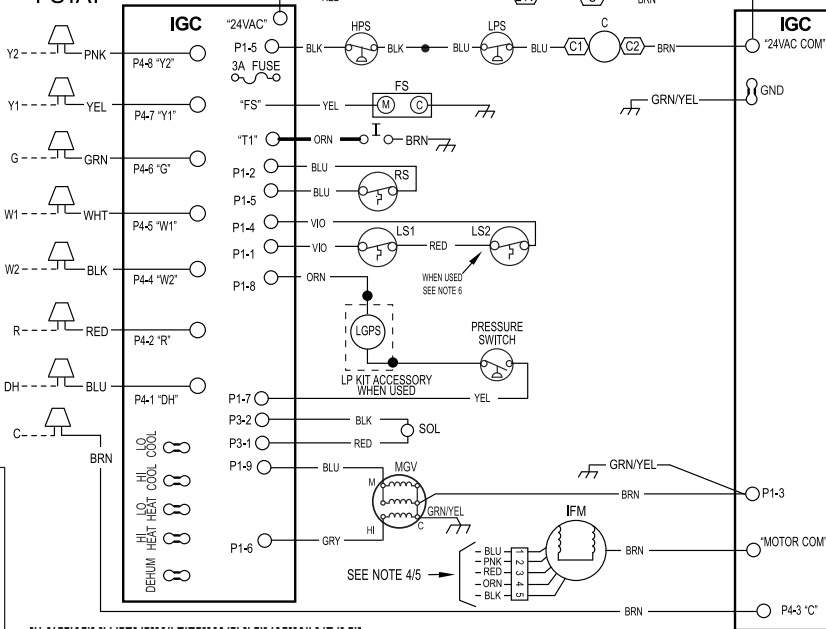

48VG500093 REV. H

48VG500093 REV. A



A14594

CONNECTION WIRING SCHEMATIC GAS INPUTS 40, 60, 90 K BTU/HR 208/230-3-60

CONNECTION WIRING DIAGRAM
DANGER: ELECTRICAL SHOCK HAZARD DISCONNECT POWER BEFORE SERVICING

SCHEMATIC 208/230-3-60

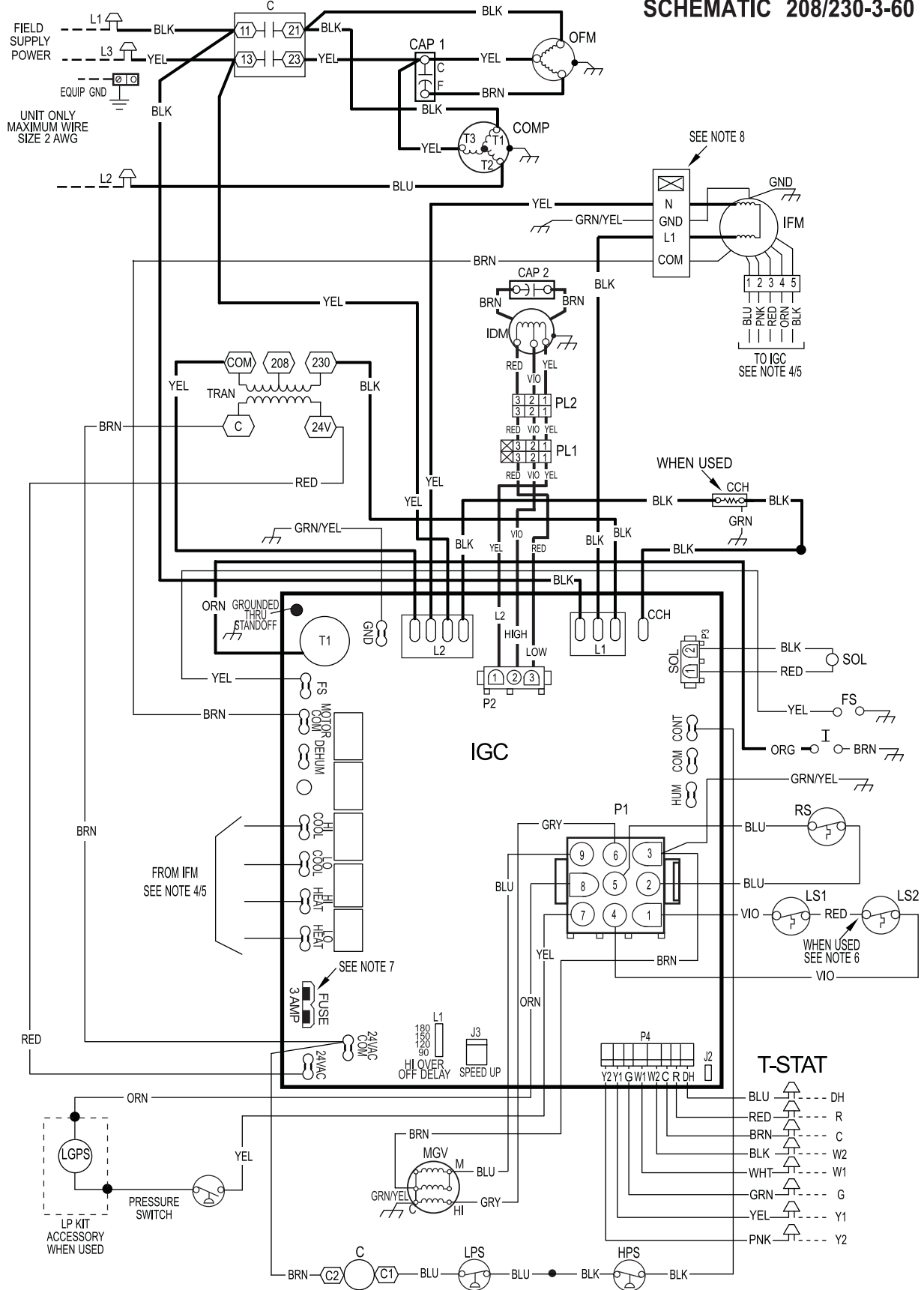

A14615

LADDER WIRING SCHEMATIC GAS INPUTS 40, 60, 90 K BTU/HR 208/230-3-60

LADDER WIRING DIAGRAM

DANGER: ELECTRICAL SHOCK HAZARD DISCONNECT POWER BEFORE SERVICING

LEGEND		
	FIELD SPLICE	EQUIP
	TERMINAL (MARKED)	FS
	TERMINAL (UNMARKED)	GND
	SPLICE	HPS
	SPLICE (MARKED)	I
	FACTORY LO VOLTAGE	IDM
	FIELD CONTROL WIRING	IFM
	FIELD POWER WIRING	IGC
	ACCESSORY OR OPTIONAL WIRING	LGPS
	FACTORY HI VOLTAGE	LPS
C	CONTACTOR	LS1
CAP1	CAPACITOR, COMP	LS2
CAP2	CAPACITOR, INDUCER	MGV
CCH	CRANKCASE HEATER	OFM
COMP	COMPRESSOR MOTOR	OT
		PL1
		PL2
		RS
		SOL
		TRAN
		T-STAT
		EQUIPMENT
		FLAME SENSOR
		GROUND
		HIGH PRESSURE SWITCH
		IGNITOR
		INDUCED DRAFT MOTOR
		INDOOR FAN MOTOR
		INTERGRATED GAS UNIT CONTROLLER
		LOW GAS PRESSURE SWITCH (WHEN USED)
		LOW PRESSURE SWITCH
		PRIMARY LIMIT SWITCH
		SECONDARY LIMIT SWITCH
		MAIN GAS VALVE
		OUTDOOR FAN MOTOR
		QUADRUPLE TERMINAL
		IGC TO INDUCER MOTOR PLUG
		INDUCER MOTOR PLUG
		ROLLOUT SWITCH
		COMPRESSOR SOLENOID
		TRANSFORMER
		THERMOSTAT

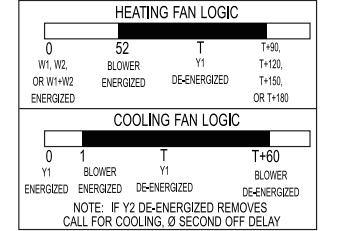
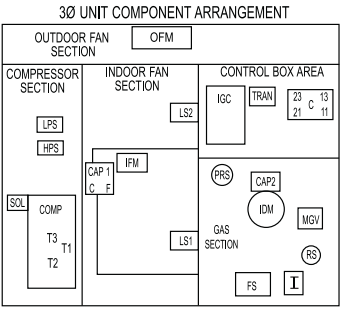

- NOTES:**
- IF ANY OF THE ORIGINAL WIRES FURNISHED ARE REPLACED THEY MUST BE REPLACED WITH THE SAME WIRE OR IT'S EQUIVALENT.
 - SEE PRE-SALE LITERATURE FOR THERMOSTATS.
 - USE 75 DEGREES C COPPER CONDUCTORS FOR FIELD INSTALLATION.
 - REFER TO INSTALLATION INSTRUCTIONS FOR CORRECT SPEED SELECTION FOR IFM.
 - SEE INSTALLATION INSTRUCTIONS FOR PROPER HEATING AND COOLING CONNECTIONS FOR YOUR UNIT.
 - ON SOME MODELS LS1 AND LS2 ARE WIRED IN SERIES. ON OTHER MODELS ONLY LS1 IS USED.
 - THIS FUSE IS MANUFACTURED BY LITTLE FUSE, P/N 257003.
 - DO NOT DISCONNECT PLUG UNDER LOAD.
 - N.E.C. CLASS 2, 24V.

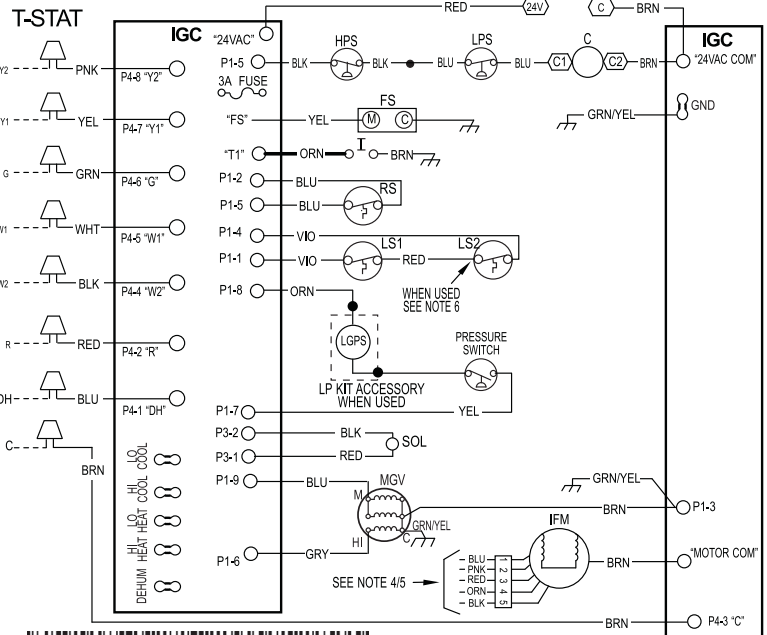
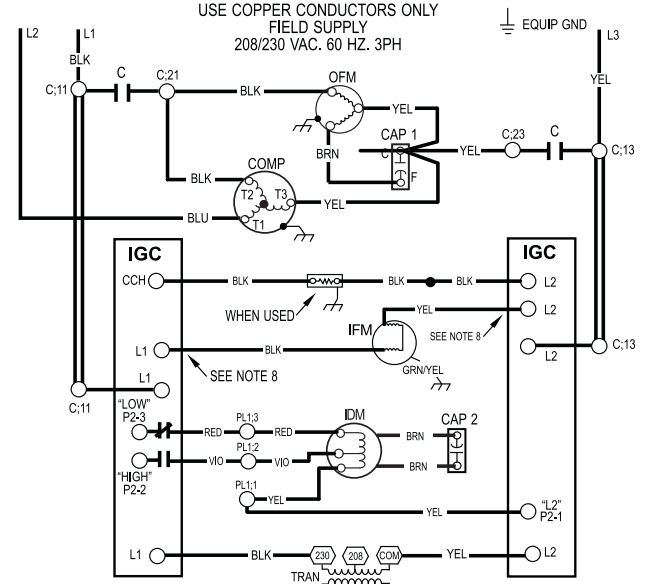

48VG500005 REV. D



CONNECTION WIRING SCHEMATIC GAS INPUTS 115, 130 K BTU/HR 208/230-3-60

CONNECTION WIRING DIAGRAM DANGER: ELECTRICAL SHOCK HAZARD DISCONNECT POWER BEFORE SERVICING

SCHEMATIC 208/230-3-60

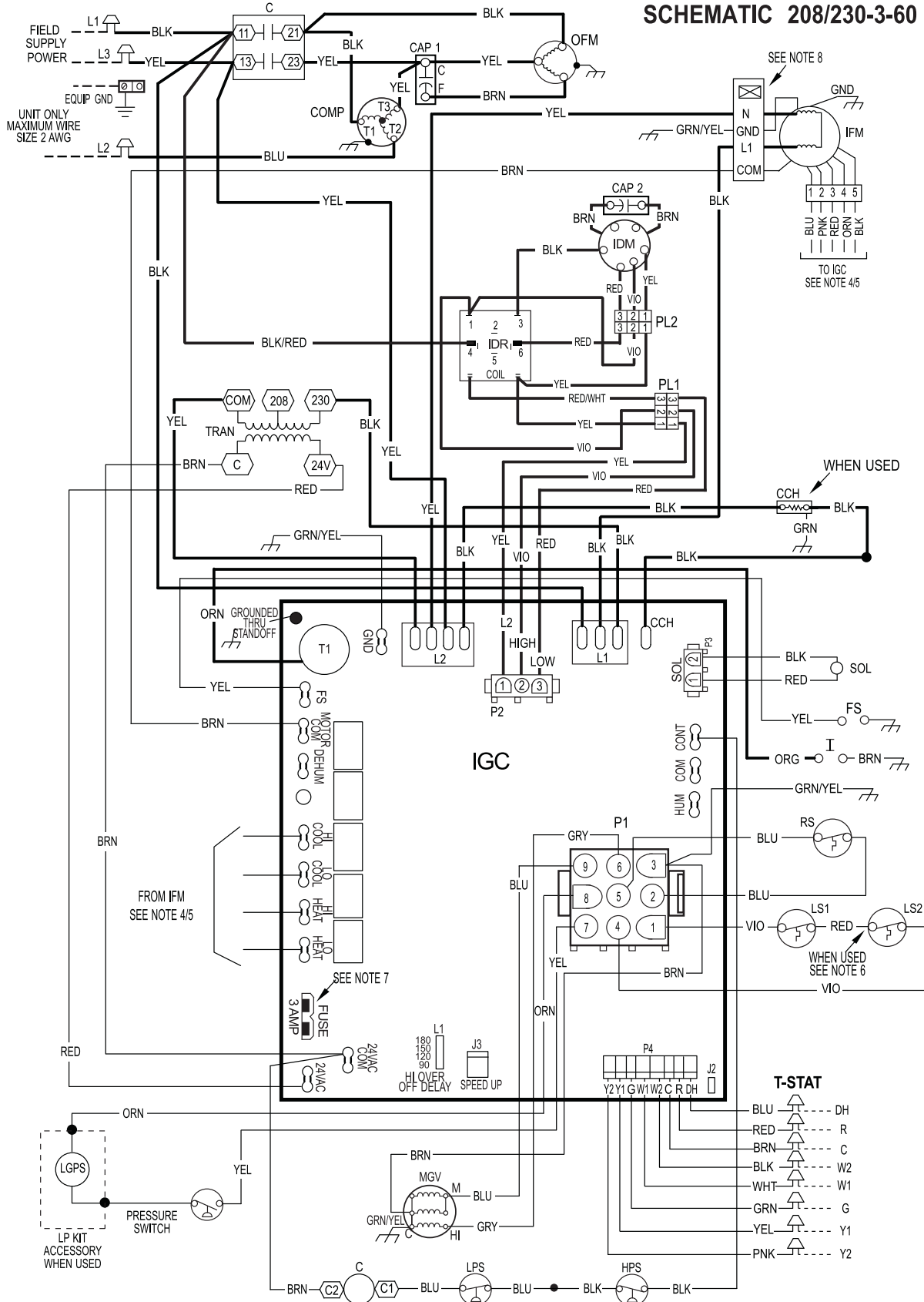

A14618

LADDER WIRING SCHEMATIC GAS INPUTS 115, 130 K BTU/HR 208/230-3-60

LADDER WIRING DIAGRAM

WARNING: DANGER: ELECTRICAL SHOCK HAZARD DISCONNECT POWER BEFORE SERVICING

LEGEND

△	FIELD SPLICE	EQUIP	EQUIPMENT
○	TERMINAL (MARKED)	FS	FLAME SENSOR
○	TERMINAL (UNMARKED)	GND	GROUND
●	SPLICE	HPS	HIGH PRESSURE SWITCH
○	SPLICE (MARKED)	I	IGNITOR
—	FACTORY LO VOLTAGE	IDM	INDUCED DRAFT MOTOR
---	FIELD CONTROL WIRING	IDR	INDUCER RELAY
---	FIELD POWER WIRING	IFM	INDOOR FAN MOTOR
---	ACCESSORY OR OPTIONAL WIRING	IGC	INTEGRATED GAS UNIT CONTROLLER
---	FACTORY HI VOLTAGE	LGPS	LOW GAS PRESSURE SWITCH (WHEN USED)
C	CONTACTOR	LPS	LOW PRESSURE SWITCH
CAP1	CAPACITOR, COMP	LS1	PRIMARY LIMIT SWITCH
CAP2	CAPACITOR, INDUCER	LS2	SECONDARY LIMIT SWITCH
CCH	CRANKCASE HEATER	MGV	MAIN GAS VALVE
COMP	COMPRESSOR MOTOR	OFM	OUTDOOR FAN MOTOR
		OT	QUADRUPLE TERMINAL
		PL1	IGC TO INDUCER MOTOR PLUG
		PL2	INDUCER MOTOR PLUG
		RS	ROLLOUT SWITCH
		SOL	COMPRESSOR SOLENOID
		TRAN	TRANSFORMER
		T-STAT	THERMOSTAT

30 UNIT COMPONENT ARRANGEMENT

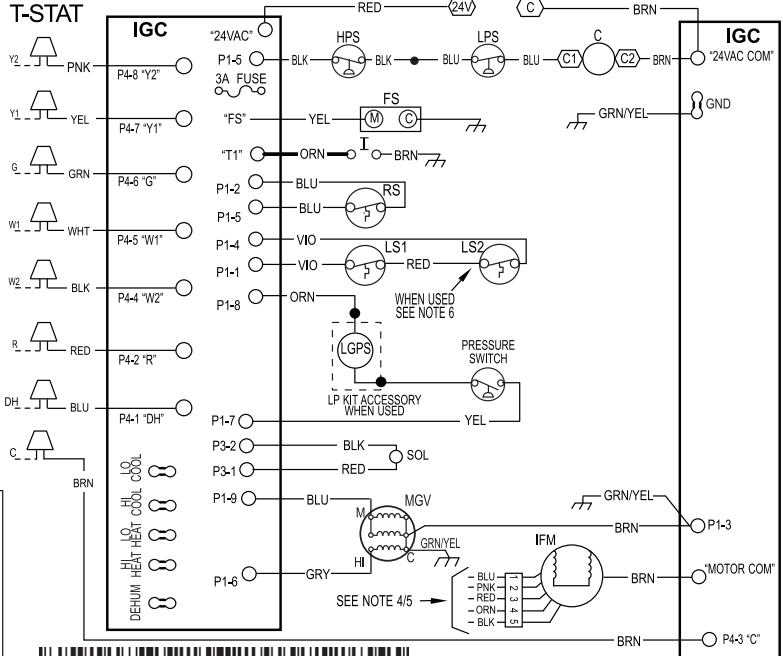
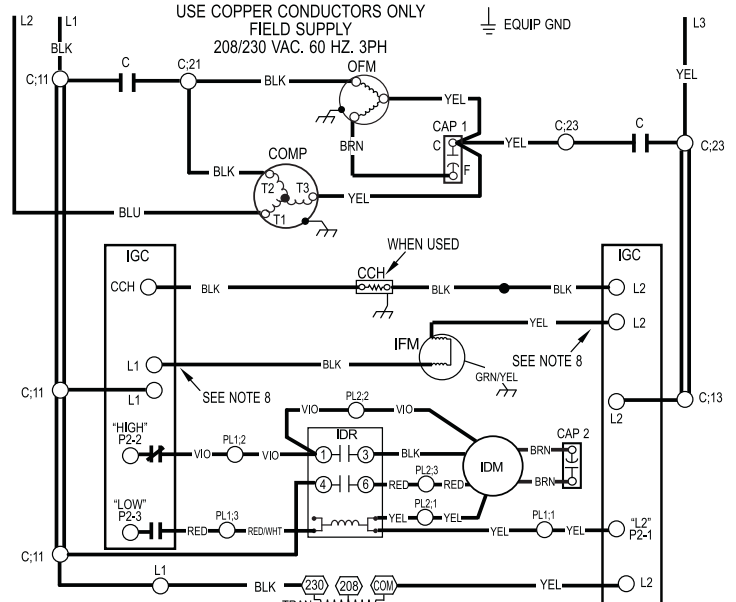
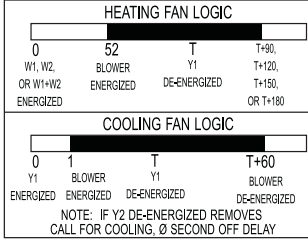
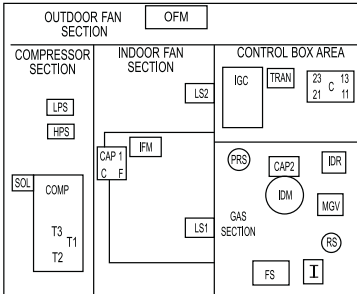

- NOTES:**
- IF ANY OF THE ORIGINAL WIRES FURNISHED ARE REPLACED THEY MUST BE REPLACED WITH THE SAME WIRE OR ITS EQUIVALENT.
 - SEE PRE-SALE LITERATURE FOR THERMOSTATS.
 - USE 75 DEGREES C COPPER CONDUCTORS FOR FIELD INSTALLATION.
 - REFER TO INSTALLATION INSTRUCTIONS FOR CORRECT SPEED SELECTION FOR IFM.
 - SEE INSTALLATION INSTRUCTIONS FOR PROPER HEATING AND COOLING CONNECTIONS FOR YOUR UNIT.
 - ON SOME MODELS LS1 AND LS2 ARE WIRED IN SERIES. ON OTHER MODELS ONLY LS1 IS USED.
 - THIS FUSE IS MANUFACTURED BY LITTLE FUSE, P/N 257003.
 - DO NOT DISCONNECT PLUG UNDER LOAD.
 - N.E.C. CLASS 2, 24V.



CONTROLS

Operating sequence

208/230 VAC Models:

On a call for low stage heating, terminal W1 on the thermostat is energized. On a call for high stage heating both terminals W1 and W2 are energized. Regardless of the stage of the heating call, the induced-draft motor is turned on to high speed for a 15 sec pre-purge time. After the pre-purge, when the pressure switch senses that sufficient combustion air is being moved by the induced-draft motor, the ignition sequence begins. The IGC will energize the sparkers and the low stage gas valve solenoid. Upon sensing flame, the IGC will check the heating call. If W2 is not energized, the IGC will drop the induced-draft motor to low speed and maintain the gas valve on low stage. If W2 is energized, the IGC will maintain the induced-draft motor on high speed and energize the high stage gas valve solenoid. Thirty sec after flame is sensed the IGC will turn on the evaporator fan motor. If W2 is not energized, the evaporator fan motor will run on low heat speed. If W2 is energized, the evaporator fan motor will run on high heat speed. After the call for heat is satisfied, the IGC will run the evaporator fan motor an additional field-selectable time of 90, 120, 150, or 180 sec before shutting the evaporator fan motor off.

GUIDE SPECIFICATIONS

Packaged Gas Heating/Electric Cooling Units

Constant Volume Application

HVAC Guide Specifications

Size Range: **2 to 5 Tons, Nominal Cooling
40,000 to 130,000 Btuh,
Nominal Heating Input**

SYSTEM DESCRIPTION

Outdoor rooftop or ground mounted air conditioner and gas furnace system utilizing a two-stage scroll compressor for cooling duty. Unit shall discharge supply air vertically or horizontally as shown on contract drawings. Outdoor fan/coil section shall have a draw-thru design with vertical discharge for minimum sound levels.

QUALITY ASSURANCE

- A. Unit shall be rated in accordance with AHRI Standards 210/240 and 270- 1995.**
- B. Unit shall be designed in accordance with UL Standard 1995 and ANSI Z 21.47.**
- C. Unit shall be manufactured in a facility registered to ISO 9001 manufacturing quality standard.**
- D. Unit shall be UL listed and c-UL certified as a total package for safety requirements.**
- E. Roof curb shall be designed to conform to NRCA Standards.**
- F. Insulation and adhesives shall meet NFPA 90.1 requirements for flame spread and smoke generation.**
- G. Cabinet insulation shall meet ASHRAE Standard 62.2.**

DELIVERY, STORAGE AND HANDLING

Unit shall be stored and handled per manufacturer's recommendations.

Part 2 — Products

EQUIPMENT

A. General:

Factory-assembled, single-piece, heating and cooling unit. Contained within the enclosure shall be all factory wiring, piping, controls, refrigerant charge with R-410A refrigerant, and special features required prior to field start-up.

B. Unit Cabinet:

1. Unit cabinet shall be constructed of phosphated, zinc-coated, pre-painted steel capable of with-standing 500 hours in salt spray.
2. Normal service shall be through 3 removable cabinet panels.
3. The unit shall be constructed on a rust proof unit base that has an externally trapped, integrated sloped drain.
4. Evaporator fan compartment top surface shall be insulated with a minimum 1/2-in. (12.7 mm) thick, flexible fiberglass insulation, coated on the air side and retained by adhesive and mechanical means. The evaporator wall sections will be insulated with a minimum semi-rigid foil-faced board capable of being wiped clean. Aluminum foil-faced fiberglass insulation shall be used in the entire indoor air cavity section.
5. Unit shall have a field-supplied condensate trap.

C. Fans:

1. The evaporator fan shall be a multi-speed, direct-drive, as shown on equipment drawings.
2. Fan wheel shall be made from steel, be double-inlet type with forward curved blades with corrosion resistant finish. Fan wheel shall be dynamically balanced.
3. Condenser fan shall be direct drive propeller type with aluminum blades riveted to corrosion resistant steel spiders, be dynamically balanced, and discharge air vertically.

D. Compressor:

1. Fully hermetic compressors with factory-installed vibration isolation.
2. Two-stage scroll compressors shall be standard on all units.

E. Coils:

Evaporator and condenser coils shall have aluminum plate fins mechanically bonded to seamless copper tubes with all joints brazed. Tube sheet openings shall be belled to prevent tube wear.

F. Heating Section:

1. Induced-draft combustion type with energy saving direct spark ignition system and redundant main gas valve.
2. Induced-draft motors shall provide adequate airflow for combustion.
3. The heat exchangers shall be constructed of aluminized steel for corrosion resistance.
4. Burners shall be of the in-shot type constructed of aluminum coated steel.
5. All gas piping and electric power shall enter the unit cabinet at a single location.

G. Refrigerant Components:

Refrigerant expansion device shall be of the TXV (thermostatic expansion valve) type.

H. Filters:

Filter section shall consist of field-installed, throwaway, 1-in. (25 mm) thick fiberglass filters of commercially available sizes.

I. Controls and Safeties:

1. Unit controls shall be complete with a self-contained low voltage control circuit.
2. Compressors shall incorporate a solid-state compressor protector that provides reset capability.

GUIDE SPECIFICATIONS (CONT)

J. Operating Characteristics:

1. Unit shall be capable of starting and running at 125°F (51°C) ambient outdoor temperature per maximum load criteria of AHRI Standard 210.
2. Compressor with standard controls shall be capable of operation down to 40°F (4°C) ambient outdoor temperature.
3. Units shall be provided with fan time delay to prevent cold air delivery before the heat exchanger warms up.
4. Unit shall be provided with fan time delay after the thermostat is satisfied.

K. Electrical Requirements:

All unit power wiring shall enter the unit cabinet at a single location.

L. Motors:

1. Compressor motors shall be of the refrigerant-cooled type with line-break thermal and current overload protection.
2. All fan motors shall have permanently lubricated bearings, and inherent, automatic reset, thermal overload protection.
3. Condenser fan motor shall be totally enclosed.
4. Evaporator Fan Motor to be multi-speed ECM blower motor.

M. Compressor Protection:

Solid-state control shall protect compressor by preventing "short cycling."

N. Low NOx:

Shall provide NOx reduction to values below 40 nanograms/joule to meet California's and other localities' emission requirements as shipped from factory.

O. Special Option/Kits Available:

1. Coil Options
Base unit with tin plated indoor coil hairpins available as a factory installed option.
2. Compressor Start Kit (single phase units only):
Shall provide additional starting torque for single-phase compressors.
3. Corporate Thermostat:
To provide for one-stage heating and cooling in addition manual or automatic changeover and indoor fan control.
4. Crankcase Heater Kit:
Shall provide anti-floodback protection for low-load cooling applications.
5. Economizer for two-stage operation:
(Horizontal and Vertical with Jade Honeywell W7220 controller, Honeywell communicating actuator, and dry bulb sensor. (Contact MicroMetl Customer Service at 1-800-662-4822 to order.)
NOTE: The enhanced dehumidification feature on high stage cooling does not support use of an economizer.

- a. Economizer controls capable of providing free cooling using outside air.
 - b. Equipped with low leakage dampers not to exceed 3% leakage, at 1.0 IN. W.C. pressure differential.
 - c. Spring return motor shuts off outdoor damper on power failure.
6. Filter Rack Option or Kit:
Shall provide filter mounting for downflow applications. Offered as an accessory or as a factory installed option.
 7. Flat Roof Curb Kit:
Curbs shall have seal strip and a wood nailer for flashing and shall be installed per manufacturer's instructions.
 8. Flue Discharge Deflector Kit
Directs flue gas exhaust; 90 degrees upward from current discharge.
 9. Heat Exchanger Option
Stainless Steel Heat Exchanger available as a factory installed option.
 10. High Altitude Propane Conversion Kit:
Shall consist of all required hardware to convert to propane gas heat operation at 2001 to 6000 ft (611 to 1829 m) above sea level.
 11. Low Ambient Package Kit:
Shall consist of a solid-state control and condenser coil temperature sensor for controlling condenser-fan motor operation, which shall allow unit to operate down to 0°F (-18°C) outdoor ambient temperature when properly installed.
 12. Manual Outdoor Air Damper Kit:
Package shall consist of damper, birdscreen, and rainhood which can be preset to admit outdoor air for year-round ventilation.
 13. Natural-to-Propane Conversion Kit:
Shall be complete with all required hardware to convert to propane gas operation at 10.0 IN. W.C. manifold pressure.
 14. Propane-to-Natural Conversion Kit
Shall be complete with all hardware to convert to natural gas at standard altitude (0 to 2000 ft [0 to 610 m] above sea level).
 15. Square-To-Round Duct Transitions Kit (24-48 models):
Shall have the ability to convert the supply and return openings from rectangular to round.
 16. Cabinet Leakage
Cabinet air leakage less than 2.0% at 0.5 inch W.C. when tested in accordance with ASHRAE standard 193. Available as a factory installed option.

PGR5 ACCESSORIES		
Accessory Model Number	Description	Use With
CURBS		
CPRFCURB011B00	Roof Curb, 14" High	24 - 60
CPRFCURB013B00	Roof Curb, 14" High	36 - 60
Note: CPRFCURB011B00 can be used with 36- 60 size units with some overhang.		
ADAPTER CURBS*		
CPADCURB001A00	Adapter curb for use with NPRFCURB006A00 & NPRFCURB007A00	24 - 30
CPADCURB002A00	Adapter curb for use with NPRFCURB008A00 & NPRFCURB009A00	36 - 60
* Can also be used when replacing other manufacturer's older generation units that contain a composite base without a metal base rail.		
CONCENTRIC ADAPTERS - (Use with curb only)		
NPCONADP001A00	For 18" round duct (use with curbs CPRFCURB011B00)	Small Curb
NPCONADP002A00	For 18" round duct (use with curbs CPRFCURB013B00)	Large Curb
* A field supplied 18" to 16" round reducer required when used with NP concentric adaptor		
DAMPERS		
CPMANDPR007A00	Manual Outside Air Damper - (Includes filter rack and 1" filter, same as CPFILTRK kit)	24 - 30
CPMANDPR008A00		36 - 42
CPMANDPR009A00		48 - 60
ECONOMIZER		
ECD- SDSML- JC2- ADB*	Vertical economizer with Jade Honeywell W7220 controller, Honeywell communicating actuator, and dry bulb sensor. (Contact MicroMetl Customer Service at 1- 800- 662- 4822 to order)	24 - 30
ECD- SDLGS- JC2- ADB*		36 - 42
ECD- SDLGB- JC2- ADB*		48 - 60
ECH- SDSML- JC2- ADB*	Horizontal economizer with Jade Honeywell W7220 controller, Honeywell communicating actuator, and dry bulb sensor. (Contact MicroMetl Customer Service at 1- 800- 662- 4822 to order)	24 - 30
ECH- SDLGS- JC2- ADB*		36 - 42
ECH- SDLGB- JC2- ADB*		48 - 60
* Contact MicroMetl Customer Service at 1- 800- 662- 4822 to order.		
INTERNAL FILTER RACKS		
CPFILTRK007A00	Internal Filter Rack (includes 1- inch filters)	24 - 30
CPFILTRK008A00		36 - 42
CPFILTRK009A00		48 - 60
LOW AMBIENT, ANTI- CYCLE, COMPRESSOR START ASSIST		
CPLOWAMB001A00	Low Ambient Control - enables cooling system to operate down to 0 Deg. F by cycling condenser fan on and off.	ALL
NRTIMEGD001A00	Five Minute Compressor Delay	ALL
CPHSTART002A00	PTC Compressor Start Assist Kit	ALL
CRANKCASE HEATERS (Factory installed on some models)		
CPCRKHTR008A00	Crankcase Heater (single phase)	24 - 36
CPCRKHTR004A00	Crankcase Heater (single and 3- phase)	42 - 48
GAS CONVERSION KITS		
NPLPCONV013C00	Natural to LP Conversion Kit (0 - 2000')	ALL
NPLPCONV014C00	Natural to LP Conversion Kit (2001' - 6000')	ALL
NPNGCONV004C00	LP to Natural Gas Conversion Kit (0 - 2000')	ALL
FLUE DISCHARGE DEFLECTOR		
CPFLUEDS001A00	Directs flue gas exhaust 90 degrees upward from current discharge. Designed to allow tighter distances between unit and combustible surfaces. 24 inch Height. AGA certified.	ALL
DUCT TRANSITIONS		
NPDUCFLG002A00	Square to Round (1 set of 2, use with horizontal duct flanges only)	24 - 48
THERMOSTATS		
TSTAT0408	Universal Programmable Thermostat with Humidity Sensing and Control, Dual Fuel compatible, 2-stage cool, 2-stage gas heat, 2-stage HP heat, 2-stage electric heat.	ALL
TSTAT0201CW	Observer Communicating Touchscreen Thermostat with Humidity Sensing and Control, Dual Fuel compatible, 2-stage cool, 2-stage gas heat, 2-stage HP heat, 2-stage electric heat.	ALL
NAXA00101DB	Daughter Board, use with communicating thermostat TSTAT0201CW and non-communicating equipment	ALL

