



14 SEER, 12 EER, 8.0 HSPF, PACKAGE HEAT PUMP, 2 to 5 TONS

Single Phase, 208/230 V, 60 Hz.

REFRIGERATION CIRCUIT

- R-410A refrigerant
- Copper tube/aluminum fin condenser and evaporator coils
- Scroll compressors standard on all models
- Short-cycling protection for the compressor is built into the defrost control board

EASY TO INSTALL AND SERVICE

- Installs easily on a rooftop or at ground level
- Easy single-panel accessibility for maintenance and installation
- Easily converts to down discharge applications
- Combination electric heating and cooling

BUILT TO LAST

- Wire Grille
- Direct drive high efficiency X-13 blower motor on all models
- Heavy-duty pre-painted steel cabinet
- Vertical condenser fan discharge
- Rust-proof base with integral sloping drain
- High and low pressure switches provide added reliability for the compressor

WARRANTY*

- 5-year compressor limited warranty
- 5 year parts limited warranty (including compressor and coils)
 - With timely registration, an additional 5 year parts limited warranty (including compressor and coils)

* Applies to original purchaser/homeowner, some limitations may apply. See warranty certificate for complete details.



As an Energy Star® Partner, International Comfort Products has determined that this product meets the ENERGY STAR® guidelines for energy efficiency.



UNIT PERFORMANCE DATA

Model Number	COOLING				HEATING HSPF	Unit Dimensions Height x Width x Depth in (mm)	Operating Weight lb / kg
	Nominal Tons	Net Capacity BTU/h	S.E.E.R*	E.E.R**			
PHN424000K00A	2	23,000	14.5	12.0	8.0	39x48x33 (991x1226x831)	306 / 139
PHN430000K00A	2-1/2	29,000	14.5	12.0	8.0	43x48x33 (1093x1226x831)	316 / 143
PHN436000K00A	3	36,000	14.5	12.0	8.0	41x48x44 (1041x1226x1123)	371 / 168
PHN442000K00A	3-1/2	41,000	14.5	12.0	8.0	47x48x44 (1194x1226x1123)	412 / 187
PHN448000K00A	4	46,000	14.5	12.0	8.0	47x48x44 (1194x1226x1123)	432 / 196
PHN460000K00A	5	59,000	14.2	12.0	8.0	51x48x44 (1295x1226x1123)	462 / 210

* Rated in accordance with U.S. Government DOE (Department of Energy) test procedures and/or ARI Standards 210/240.

** "A" conditions-80°F (26.6°C) indoor db/67°F (19.4°C) indoor wb & 95°F (35°C) outdoor db.

UNIT SPECIFICATIONS

MODEL NUMBER	Electrical Data			Condenser								Sound Ratings (dBA)
				Coil			Fan Motor		Fan			
	208 / 230 Voltage Phase - Hz	HACR Brkr Max Fuse	Minimum Circuit Ampacity	Total Face Area (Sq. Ft.)	Fins Per In. / Rows	Tube Diameter (In.)	HP	Full Load Amps	Size Diameter (In.)	RPM (Max.)	CFM (Design)	
PHN424000K00A	1-60	30 amps.	21.8	13.6	21 / 2	3 / 8	1 / 8	0.9	22	825	2500	74
PHN430000K00A	1-60	35 amps.	22.9	15.4	21 / 2	3 / 8	1 / 8	0.9	22	825	2600	72
PHN436000K00A	1-60	40 amps.	28.3	13.6	21 / 2	3 / 8	1 / 4	1.5	22	1100	3000	78
PHN442000K00A	1-60	50 amps.	33.6	19.4	21 / 2	3 / 8	1 / 8	0.9	22	825	3500	75
PHN448000K00A	1-60	50 amps.	36.8	19.4	21 / 2	3 / 8	1 / 4	1.5	22	1100	3500	78
PHN460000K00A	1-60	60 amps.	42.5	23.3	21 / 2	3 / 8	1 / 3	1.9	22	1100	3500	79

MODEL NUMBER	Evaporator							Scroll Compressor		Factory Refrigerant Charge R-410A lbs. (kg)
	Coil			Motor		Blower		Rated Load Amps	Locked Rotor Amps	
	Total Face Area (Sq. Ft.)	Fins Per In. / Rows	Tube Diam. (In.)	HP	Full Load Amps	Size	CFM Rated			
PHN424000K00A	3.7	17 / 3	3 / 8	1/2	4.1	10 x 10	800	13.5	58.3	9.5 (4.3)
PHN430000K00A	3.7	17 / 3	3 / 8	1/2	4.1	10 x 10	1000	14.3	73.0	10.5 (4.8)
PHN436000K00A	4.7	17 / 3	3 / 8	3/4	6.0	11 x 10	1200	16.7	79.0	9.0 (4.1)
PHN442000K00A	4.7	17 / 3	3 / 8	3/4	6.0	11 x 10	1400	21.4	112.0	14.0 (6.4)
PHN448000K00A	5.7	17 / 3	3 / 8	1.0	7.6	11 x 10	1600	22.1	109.0	17.0 (7.7)
PHN460000K00A	5.7	17 / 4	3 / 8	1.0	7.6	11 x 10	1750	26.4	134.0	16.0 (7.3)

UNIT PERFORMANCE DATA - HEATING

Model Number	HEATING			
	High Heat Capacity BTU/h @ 47°F (8.3°C)	High Heat COP @ 47°F (8.3°C)	Low Heat Capacity BTU/h @ 17°F (-8.3°C)	Low Heat COP @ 17°F (-8.3°C)
PHN424000K00A	23,600	3.4	12,500	2.2
PHN430000K00A	29,000	3.5	15,500	2.2
PHN436000K00A	34,800	3.5	18,700	2.2
PHN442000K00A	41,000	3.5	22,600	2.3
PHN448000K00A	45,500	3.3	23,800	2.3
PHN460000K00A	60,000	3.5	33,600	2.3

UNIT SIZE	PHN424	PHN430	PHN436	PHN442	PHN448	PHN460
HIGH-PRESSURE SWITCH (psig) Cutout Reset (Auto)	650±15 420±25					
LOSS-OF-CHARGE / LOW-PRESSURE SWITCH Liquid Line) (psig) Cutout Reset (Auto)	20±5 45±5					
RETURN-AIR FILTERS* Throwaway in. (mm)	20x20x1 (508x508x25)	20x24x1 (508x610x25)	24x30x1 (610x762x25)		24x36x1 (610x914x25)	

UNIT SPECIFICATIONS

ELECTRIC HEATER USAGE CHART

Electric Heater Model Number	Nominal Capacity (kW)	Fuses	Used With Model Sizes					
			24	30	36	42	48	60
ELECTRIC HEATERS (208 / 230 — SINGLE PHASE — 60 Hz)								
EHNA05K0N	5.0	0	✓	✓	✓			
EHNA05K4F	5.0	4				✓	✓	✓
EHNA07K4F	7.2	4	✓	✓	✓	✓	✓	✓
EHNA10K4F	10.0	4	✓	✓	✓	✓	✓	✓
EHNA15K6F	15.0	6		✓	✓	✓	✓	✓
EHNA20K6F	20.0	6				✓	✓	✓

ELECTRIC HEATER ELECTRICAL DATA

MODEL SIZE	NOMINAL V-PH-HZ	VOLTAGE RANGE		ELECTRIC HEAT (208V / 230V)		POWER SUPPLY (208V / 230V)	
		MIN	MAX	NOMINAL kW	Full Load Ampacity	Minimum Circuit Ampacity	Maximum Over-Current Protection
24	208 / 230-1-60	187	253	3.8 / 5	18.1 / 20.8	44.4 / 47.9	45 / 50
				5.4 / 7.2	25.9 / 30.0	54.3 / 59.3	70 / 80
				7.5 / 10	36.1 / 41.7	67.0 / 73.9	70 / 80
30	208 / 230-1-60	187	253	3.8 / 5	18.1 / 20.8	45.4 / 48.9	50 / 50
				5.4 / 7.2	25.9 / 30.0	55.3 / 60.3	60 / 70
				7.5 / 10	36.1 / 41.7	68.0 / 75.0	70 / 80
36	208 / 230-1-60	187	253	3.8 / 5	18.1 / 20.8	50.9 / 54.4	60 / 60
				5.4 / 7.2	25.9 / 30.0	60.8 / 65.8	70 / 70
				7.5 / 10	36.1 / 41.7	73.5 / 80.4	80 / 90
42	208 / 230-1-60	187	253	3.8 / 5	18.1 / 20.8	90.6 / 101.0	100 / 110
				5.4 / 7.2	25.9 / 30.0	56.2 / 59.7	60 / 60
				7.5 / 10	36.1 / 41.7	66.1 / 71.1	70 / 80
48	208 / 230-1-60	187	253	11.3 / 15	54.2 / 62.5	78.8 / 85.7	80 / 90
				15 / 20	72.2 / 83.3	101.3 / 111.8	110 / 125
				3.8 / 5	18.1 / 20.8	123.9 / 137.8	125 / 150
60	208 / 230-1-60	187	253	5.4 / 7.2	25.9 / 30.0	59.3 / 62.8	60 / 70
				7.5 / 10	36.1 / 41.7	69.2 / 74.2	70 / 80
				11.3 / 15	54.2 / 62.5	81.9 / 88.9	90 / 90
				15 / 20	72.2 / 83.3	104.5 / 114.9	110 / 125
				3.8 / 5	18.1 / 20.8	127.0 / 140.9	150 / 150
				5.4 / 7.2	25.9 / 30.0	65.1 / 68.5	70 / 70
				7.5 / 10	36.1 / 41.7	74.9 / 79.9	80 / 80
				11.3 / 15	54.2 / 62.5	87.6 / 94.6	90 / 100
				15 / 20	72.2 / 83.3	110.2 / 120.6	125 / 125
						132.8 / 146.7	150 / 150

UNIT AIRFLOW, Horizontal Discharge CFM, Dry Coil

Unit	Motor Speed	Wire Color	External Static Pressure (IN. W.C.)								
			0.1	0.2	0.3	0.4	0.5	0.6	0.7	0.8	0.9
PHN424	Low	Blue	741	638	547	415	---	---	---	---	---
	Med-Low ¹	Pink	898	820	738	662	536	---	---	---	---
	Medium	Red	973	887	823	733	665	538	451	---	---
	Med-High	Orange	1140	1064	996	915	840	758	687	564	480
PHN430	High	Black	1202	1140	1082	1015	961	881	810	732	631
	Low	Blue	741	638	547	415	---	---	---	---	---
	Med-Low	Pink	898	820	738	662	536	---	---	---	---
	Medium	Red	973	887	823	733	665	538	451	---	---
PHN436	Med-High ¹	Orange	1140	1064	996	915	840	758	687	564	480
	High ¹	Black	1202	1140	1082	1015	961	881	810	732	631
	Low	Blue	1295	1234	1182	1126	1075	1016	955	898	857
	Med-Low ¹	Pink	1345	1282	1235	1194	1140	1095	1027	974	921
PHN442	Medium	Red	1505	1452	1413	1358	1323	1282	1234	1169	1130
	Med-High	Orange	1545	1492	1449	1411	1362	1313	1278	1231	1188
	High	Black	1705	1643	1607	1568	1518	1483	1448	1404	1360
	Low	Blue	1295	1234	1182	1126	1075	1016	955	898	857
PHN448	Med-Low	Pink	1345	1282	1235	1194	1140	1095	1027	974	921
	Medium	Red	1505	1452	1413	1358	1323	1282	1234	1169	1130
	Med-High ¹	Orange	1545	1492	1449	1411	1362	1313	1278	1231	1188
	High	Black	1705	1643	1607	1568	1518	1483	1448	1404	1360
PHN460	Low	Blue	1445	1389	1341	1281	1236	1189	1139	1072	1027
	Med-Low ¹	Pink	1678	1635	1602	1558	1513	1474	1438	1404	1349
	Medium	Red	1962	1915	1880	1843	1794	1753	1711	1675	1628
	Med-High	Orange	2131	2088	2065	2013	1982	1941	1888	1860	1785
PHN460	High	Black	2461	2409	2339	2286	2192	2140	2062	1968	1874
	Low	Blue	1448	1321	1282	1235	1192	1145	1101	1057	1011
	Med-Low	Pink	1722	1675	1614	1543	1499	1442	1408	1356	1308
	Medium ¹	Red	1887	1847	1783	1726	1677	1625	1578	1527	1432
PHN460	Med-High	Orange	2055	2008	1958	1927	1900	1768	1685	1581	1458
	High	Black	2292	2238	2158	2049	1935	1840	1732	1635	1513

* Air delivery values are without air filter and are for dry coil (See Wet Coil Pressure Drop Table).

¹ Factory – shipped cooling/heat pump heating speed

NOTE: Deduct field – supplied air filter pressure drop and wet coil pressure drop to obtain external static pressure available for ducting.

Filter Pressure Drop Table (IN WC)

FILTER SIZE in. (mm)	CFM																		
	500	600	700	800	900	1000	1100	1200	1300	1400	1500	1600	1700	1800	1900	2000	2100	2200	2300
20X20X1 (508X508X25)	0.05	0.07	0.08	0.1	0.12	0.13	0.14	0.15	—	—	—	—	—	—	—	—	—	—	—
20X24X1 (508X610X25)	—	—	—	—	0.09	0.10	0.11	0.13	0.14	0.15	0.16	—	—	—	—	—	—	—	—
24X30X1 (610X762X25)	—	—	—	0.04	0.05	0.06	0.07	0.07	0.08	0.09	0.1	—	—	—	—	—	—	—	—
24X36X1 (610X914X25)	—	—	—	—	—	—	—	0.06	0.07	0.07	0.08	0.09	0.09	0.10	0.11	0.12	0.13	0.14	0.14

PERFORMANCE DATA-STANDARD X-13 INDOOR MOTOR

PHN424 Cooling Extended Performance Table

EVAPORATOR AIR		CONDENSER ENTERING AIR TEMPERATURES °F (°C)																				
		75 (23.9)			85 (29.4)			95 (35)			105 (40.6)			115 (46.1)			125 (51.7)					
		Capacity MBtuh		Total Sys KW	Capacity MBtuh		Total Sys KW	Capacity MBtuh		Total Sys KW	Capacity MBtuh		Total Sys KW	Capacity MBtuh		Total Sys KW	Capacity MBtuh		Total Sys KW			
CFM / BF	EWB °F (°C)	Total	Sens	Total	Sens	Total	Sens	Total	Sens	Total	Sens	Total	Sens	Total	Sens	Total	Sens	Total	Sens			
			57 (13.9)	23.20	23.20	21.79	21.79	20.35	20.35	18.87	18.87	17.34	17.34	15.72	15.72	14.20	14.20	12.67	12.67	11.15	11.15	9.62
	62 (16.7)	23.89	22.10	22.26	20.78	20.63	19.47	18.99	18.11	17.35	17.35	15.72	15.72	14.20	14.20	12.67	12.67	11.15	11.15	9.62	9.62	
700 / 0.08	63* (17.2)	24.22	17.97	22.54	16.83	20.86	15.71	19.15	14.59	17.40	13.47	15.56	12.33	12.33	10.80	10.80	9.27	9.27	7.74	7.74	6.21	6.21
	67 (19.4)	26.13	18.68	24.33	17.52	22.51	16.37	19.00	15.25	18.76	14.06	16.75	12.87	12.87	11.28	11.28	9.75	9.75	8.22	8.22	6.69	6.69
	72 (22.2)	28.61	15.23	26.64	14.20	24.63	13.18	19.00	12.15	20.48	11.12	18.24	10.05	10.05	8.46	8.46	6.91	6.91	5.38	5.38	3.86	3.86
	57 (13.9)	24.24	24.24	22.73	22.73	21.20	21.20	19.62	19.62	18.00	18.00	16.26	16.26	14.54	14.54	12.81	12.81	11.08	11.08	9.35	9.35	
	62 (16.7)	24.56	23.69	22.89	22.23	21.22	21.22	19.62	19.62	18.00	18.00	16.26	16.26	14.54	14.54	12.81	12.81	11.08	11.08	9.35	9.35	
800 / 0.09	63* (17.2)	24.83	19.13	23.09	17.95	21.33	16.77	19.55	15.59	17.72	14.39	15.82	13.15	13.15	11.58	11.58	9.85	9.85	8.12	8.12	6.39	6.39
	67 (19.4)	26.77	19.94	24.90	18.72	23.00	17.50	21.07	16.28	19.09	15.05	17.00	13.78	13.78	12.09	12.09	10.36	10.36	8.63	8.63	6.90	6.90
	72 (22.2)	29.30	16.01	27.24	14.94	25.15	13.87	19.22	12.79	21.99	12.21	18.49	10.58	10.58	8.87	8.87	7.14	7.14	5.40	5.40	3.65	3.65
	57 (13.9)	25.13	25.13	23.54	23.54	21.92	21.92	20.26	20.26	18.53	18.53	16.69	16.69	14.86	14.86	13.02	13.02	11.19	11.19	9.46	9.46	
	62 (16.7)	25.17	25.17	23.54	23.54	21.92	21.92	20.26	20.26	18.53	18.53	16.69	16.69	14.86	14.86	13.02	13.02	11.19	11.19	9.46	9.46	
900 / 0.10	63* (17.2)	25.31	20.26	23.51	19.02	21.70	17.77	19.86	16.52	17.98	15.25	16.03	13.93	13.93	12.16	12.16	10.39	10.39	8.62	8.62	6.87	6.87
	67 (19.4)	27.29	21.14	25.34	19.86	23.38	18.58	21.38	17.30	19.34	15.99	17.19	14.61	14.61	12.76	12.76	10.99	10.99	9.24	9.24	7.51	7.51
	72 (22.2)	29.85	16.75	27.72	15.64	25.55	14.52	19.44	13.40	22.34	12.76	18.67	11.09	11.09	9.32	9.32	7.59	7.59	5.88	5.88	4.15	4.15

*At 75°F (23.9 °C) entering dry bulb—Tennessee Valley Authority [TVA] rating conditions; all others at 80°F (26.7 °C) entering dry bulb. See Legend and Notes.

PHN424 Heating Extended Performance Table

INDOOR AIR		OUTDOOR COIL ENTERING AIR TEMPERATURES °F (°C)																							
		-10 (-23.3)			0 (-17.8)			10 (-12.2)			20 (-6.7)			30 (-1.1)			40 (4.4)			50 (10)			60 (15.6)		
		Capacity MBtuh		Total Sys KW	Capacity MBtuh		Total Sys KW	Capacity MBtuh		Total Sys KW	Capacity MBtuh		Total Sys KW	Capacity MBtuh		Total Sys KW	Capacity MBtuh		Total Sys KW	Capacity MBtuh		Total Sys KW	Capacity MBtuh		Total Sys KW
EDB	CFM	Total	Integ	Total	Integ	Total	Integ	Total	Integ	Total	Integ	Total	Integ	Total	Integ	Total	Integ	Total	Integ	Total	Integ	Total	Integ		
			700	7.36	6.77	1.58	9.63	8.86	12.04	11.05	14.61	13.25	17.4	17.53	15.36	18.1	20.88	20.88	19.0	24.68	24.68	2.02	29.14	29.14	2.15
65 (18.3)	800	7.48	6.88	1.58	9.76	8.98	12.18	11.18	14.77	13.40	17.2	17.76	15.56	1.78	21.18	21.18	1.86	25.22	25.22	1.96	29.17	29.17	2.09		
	900	7.58	6.97	1.59	9.86	9.07	12.30	11.29	14.92	13.53	17.0	17.99	15.76	1.76	21.51	21.51	1.84	25.23	25.23	1.93	28.82	28.82	2.06		
70 (21.1)	700	7.07	6.50	1.66	9.38	8.63	11.80	10.83	14.39	13.05	1.83	17.25	15.12	1.91	20.57	20.57	2.00	24.27	24.27	2.12	28.75	28.75	2.27		
	800	7.18	6.61	1.66	9.50	8.75	11.94	10.96	14.55	13.20	1.81	17.47	15.31	1.88	20.85	20.85	1.96	24.78	24.78	2.07	28.90	28.90	2.19		
	900	7.28	6.70	1.67	9.61	8.85	12.07	11.08	14.68	13.32	1.80	17.66	15.47	1.85	21.09	21.09	2.03	25.00	25.00	2.03	28.67	28.67	2.16		
75 (23.9)	700	6.74	6.20	1.74	9.10	8.38	11.56	10.61	14.17	12.85	1.93	16.98	14.88	2.01	20.27	20.27	2.11	23.90	23.90	2.23	28.30	28.30	2.30		
	800	6.86	6.31	1.74	9.23	8.50	11.70	10.74	14.33	12.99	1.91	17.19	15.06	1.98	20.53	20.53	2.06	24.32	24.32	2.17	28.58	28.58	2.30		
	900	6.96	6.41	1.75	9.35	8.60	11.82	10.85	14.46	13.12	1.89	17.37	15.22	1.95	20.76	20.76	2.04	24.73	24.73	2.14	28.48	28.48	2.27		

PERFORMANCE DATA-STANDARD X-13 INDOOR MOTOR

PHN430 Cooling Extended Performance Table

EVAPORATOR AIR		CONDENSER ENTERING AIR TEMPERATURES °F (°C)																		
		75 (23.9)			85 (29.4)			95 (35)			105 (40.6)			115 (46.1)			125 (51.7)			
		Capacity MBtuh	Total Sys KW	Capacity MBtuh	Total Sys KW	Capacity MBtuh	Total Sys KW	Capacity MBtuh	Total Sys KW	Capacity MBtuh	Total Sys KW	Capacity MBtuh	Total Sys KW	Capacity MBtuh	Total Sys KW	Capacity MBtuh	Total Sys KW			
CFM / BF	EWB °F (°C)	Total	Sens	Total	Sens	Total	Sens	Total	Sens	Total	Sens	Total	Sens	Total	Sens	Total	Sens			
		875 / 0.05	57 (13.9)	28.47	28.47	1.94	27.21	27.21	25.85	25.85	2.37	24.39	24.39	2.62	22.78	22.78	20.95	20.95	2.88	20.95
62 (16.7)	29.18		25.42	1.94	27.67	24.95	26.09	24.39	2.37	24.42	24.42	2.62	22.78	22.78	20.95	20.95	2.88	20.95	20.95	3.15
63* (17.2)	29.61		20.60	1.94	28.05	20.16	26.40	19.65	2.38	24.64	19.08	2.62	22.73	18.41	20.62	17.62	2.89	20.62	17.62	3.15
67 (19.4)	31.91		21.40	1.95	30.23	20.46	28.45	20.46	2.38	26.52	19.88	2.63	24.44	19.21	22.12	18.39	2.90	22.12	18.39	3.16
72 (22.2)	34.97		17.28	1.96	33.11	16.85	31.12	16.32	2.39	28.99	15.72	2.64	26.68	15.03	24.10	14.20	2.90	24.10	14.20	3.17
1000 / 0.05	57 (13.9)	29.72	29.72	1.98	28.36	28.36	26.91	26.91	2.41	25.32	25.32	2.65	23.58	23.58	21.60	21.60	2.91	21.60	21.60	3.19
	62 (16.7)	29.97	27.26	1.98	28.41	28.34	26.91	26.91	2.41	25.33	25.33	2.65	23.58	23.58	21.60	21.60	2.91	21.60	21.60	3.19
	63* (17.2)	30.31	21.98	1.98	28.67	21.52	26.94	21.00	2.41	25.10	20.40	2.65	23.10	19.69	20.89	18.83	2.91	20.89	18.83	3.18
	67 (19.4)	32.64	22.87	1.99	30.88	22.42	29.00	21.90	2.42	26.98	21.29	2.66	24.80	20.58	22.39	19.70	2.92	22.39	19.70	3.19
	72 (22.2)	35.74	18.21	2.00	33.79	17.74	31.70	17.19	2.43	29.47	16.56	2.67	27.04	15.84	24.35	14.99	2.93	24.35	14.99	3.20
1125 / 0.06	57 (13.9)	30.79	30.79	2.01	29.34	29.34	27.78	27.78	2.44	26.09	26.09	2.69	24.23	24.23	22.12	22.12	2.95	22.12	22.12	3.22
	62 (16.7)	30.79	30.79	2.01	29.34	29.34	27.79	27.79	2.44	26.09	26.09	2.69	24.23	24.23	22.12	22.12	2.95	22.12	22.12	3.22
	63* (17.2)	30.85	23.30	2.01	29.15	22.83	27.36	22.29	2.44	25.44	21.65	2.68	23.38	20.89	21.11	19.95	2.94	21.11	19.95	3.21
	67 (19.4)	33.20	24.29	2.02	31.37	23.82	29.41	23.28	2.45	27.32	22.64	2.69	25.06	21.88	22.58	20.93	2.95	22.58	20.93	3.22
	72 (22.2)	36.33	19.07	2.03	34.30	18.58	32.12	18.01	2.46	29.81	17.37	2.70	27.30	16.63	24.52	15.74	2.96	24.52	15.74	3.23

*At 75°F (23.9 °C) entering dry bulb—Tennessee Valley Authority [TVA] rating conditions; all others at 80°F (26.7 °C) entering dry bulb. See Legend and Notes.

PHN430 Heating Extended Performance Table

INDOOR AIR		OUTDOOR COIL ENTERING AIR TEMPERATURES °F (°C)																							
		-10 (-23.3)			0 (-17.8)			10 (-12.2)			20 (-6.7)			30 (-1.1)			40 (4.4)			50 (10)			60 (15.6)		
		Capacity MBtuh	Total Sys KW	Capacity MBtuh	Total Sys KW	Capacity MBtuh	Total Sys KW	Capacity MBtuh	Total Sys KW	Capacity MBtuh	Total Sys KW	Capacity MBtuh	Total Sys KW	Capacity MBtuh	Total Sys KW	Capacity MBtuh	Total Sys KW	Capacity MBtuh	Total Sys KW	Capacity MBtuh	Total Sys KW	Capacity MBtuh	Total Sys KW		
EDB	CFM	Total	Integ	Total	Integ	Total	Integ	Total	Integ	Total	Integ	Total	Integ	Total	Integ	Total	Integ	Total	Integ	Total	Integ	Total	Integ		
		65 (18.3)	875	9.06	8.34	1.90	12.11	11.14	1.98	15.26	14.00	2.04	18.55	16.82	2.12	22.03	19.31	2.19	25.87	25.87	2.28	30.37	30.37	2.39	35.63
1000	9.26		8.52	1.92	12.33	11.34	1.99	15.48	14.21	2.05	18.79	17.05	2.10	22.30	19.54	2.17	26.34	26.34	2.24	30.84	30.84	2.34	36.27	36.27	2.47
1125	9.43		8.68	1.94	12.51	11.51	2.00	15.68	14.39	2.05	19.00	17.24	2.10	22.53	19.74	2.16	26.65	26.65	2.22	31.24	31.24	2.31	36.86	36.86	2.43
70 (21.1)	875	8.53	7.85	1.98	11.67	10.73	2.06	14.87	13.65	2.14	18.21	16.51	2.22	21.71	19.03	2.30	25.47	25.47	2.40	29.91	29.91	2.52	35.05	35.05	2.67
	1000	8.73	8.03	2.00	11.89	10.94	2.08	15.11	13.87	2.14	18.46	16.74	2.21	21.99	19.26	2.28	25.82	25.82	2.36	30.36	30.36	2.46	35.68	35.68	2.59
	1125	8.91	8.20	2.02	12.08	11.11	2.09	15.31	14.05	2.15	18.68	16.94	2.21	22.22	19.47	2.27	26.12	26.12	2.34	30.74	30.74	2.42	36.20	36.20	2.55
75 (23.9)	875	7.95	7.31	2.06	11.18	10.29	2.15	14.45	13.27	2.24	17.84	16.18	2.33	21.38	18.73	2.42	25.11	25.11	2.52	29.46	29.46	2.64	34.49	34.49	2.80
	1000	8.15	7.50	2.08	11.40	10.49	2.17	14.70	13.49	2.24	18.10	16.41	2.32	21.66	18.97	2.39	25.43	25.43	2.48	29.90	29.90	2.58	35.09	35.09	2.72
	1125	8.33	7.66	2.11	11.60	10.67	2.18	14.90	13.68	2.25	18.32	16.61	2.32	21.89	19.18	2.38	25.72	25.72	2.45	30.27	30.27	2.55	35.60	35.60	2.67

PERFORMANCE DATA-STANDARD X-13 INDOOR MOTOR

PHN436 Cooling Extended Performance Table

EVAPORATOR AIR		CONDENSER ENTERING AIR TEMPERATURES °F (°C)																	
		75 (23.9)			85 (29.4)			95 (35)			105 (40.6)			115 (46.1)			125 (51.7)		
		Capacity MBtuh	Total Sys KW		Capacity MBtuh	Total Sys KW		Capacity MBtuh	Total Sys KW		Capacity MBtuh	Total Sys KW		Capacity MBtuh	Total Sys KW		Capacity MBtuh	Total Sys KW	
CFM / BF	EWB °F (°C)	Total	Sens	Total	Sens	Total	Sens	Total	Sens	Total	Sens	Total	Sens	Total	Sens	Total	Sens	Total	Sens
		1050 / 0.08	57 (13.9)	38.00	38.00	2.44	34.81	34.81	2.69	31.68	31.68	2.95	28.58	28.58	3.23	25.51	25.51	3.53	22.43
62 (16.7)	39.23		34.90	2.45	35.69	32.70	2.69	32.23	30.51	2.95	28.85	28.27	3.23	25.55	25.55	3.53	22.43	22.43	3.85
63* (17.2)	39.74		28.36	2.45	36.13	28.48	2.69	32.59	24.60	2.95	29.11	22.76	3.24	25.68	20.90	3.53	22.28	19.03	3.85
67 (19.4)	42.90		29.50	2.46	39.01	27.57	2.70	35.20	25.66	2.97	31.45	23.75	3.25	27.77	21.86	3.53	24.10	19.94	3.87
72 (22.2)	46.93		24.09	2.47	42.69	22.40	2.72	38.51	20.71	2.98	34.42	19.04	3.27	30.38	17.37	3.57	26.35	15.68	3.89
1200 / 0.09	57 (13.9)	39.72	39.72	2.48	36.36	36.36	2.72	33.04	33.04	2.99	29.76	29.76	3.27	26.51	26.51	3.57	23.26	23.26	3.88
	62 (16.7)	40.35	37.43	2.48	36.71	35.04	2.72	33.12	33.12	2.99	29.77	29.77	3.27	26.52	26.52	3.57	23.26	23.26	3.88
	63* (17.2)	40.77	30.20	2.48	37.03	28.20	2.72	33.35	26.23	2.99	29.75	24.28	3.27	26.21	22.32	3.57	22.70	20.32	3.88
	67 (19.4)	43.99	31.47	2.49	39.95	29.42	2.74	36.00	27.40	3.00	32.13	25.39	3.28	28.31	23.39	3.58	24.52	21.34	3.90
	72 (22.2)	48.09	25.31	2.51	43.69	23.54	2.75	39.37	21.78	3.02	35.13	20.04	3.30	30.95	18.29	3.60	26.79	16.52	3.92
1350 / 0.10	57 (13.9)	41.20	41.20	2.51	37.67	37.67	2.76	34.19	34.19	3.02	30.76	30.76	3.30	27.36	27.36	3.60	23.95	23.95	3.92
	62 (16.7)	41.37	39.65	2.51	37.69	37.69	2.76	34.19	34.19	3.02	30.76	30.76	3.30	27.36	27.36	3.60	23.95	23.95	3.92
	63* (17.2)	41.60	31.96	2.51	37.74	29.86	2.76	33.95	27.79	3.02	30.25	25.74	3.30	26.62	23.66	3.60	23.02	21.54	3.91
	67 (19.4)	44.85	33.35	2.52	40.70	31.21	2.77	36.63	29.08	3.03	32.65	26.97	3.31	28.73	24.84	3.61	24.84	22.67	3.93
	72 (22.2)	49.01	26.47	2.54	44.48	24.63	2.78	40.03	22.80	3.05	35.68	20.98	3.33	31.39	19.16	3.63	27.12	17.31	3.95

*At 75°F (23.9 °C) entering dry bulb—Tennessee Valley Authority [TVA] rating conditions; all others at 80°F (26.7 °C) entering dry bulb. See Legend and Notes.

PHN436 Heating Extended Performance Table

INDOOR AIR		OUTDOOR COIL ENTERING AIR TEMPERATURES °F (°C)																							
		-10 (-23.3)			0 (-17.8)			10 (-12.2)			20 (-6.7)			30 (-1.1)			40 (4.4)			50 (10)			60 (15.6)		
		Capacity MBtuh	Total Sys KW		Capacity MBtuh	Total Sys KW		Capacity MBtuh	Total Sys KW		Capacity MBtuh	Total Sys KW		Capacity MBtuh	Total Sys KW		Capacity MBtuh	Total Sys KW		Capacity MBtuh	Total Sys KW		Capacity MBtuh	Total Sys KW	
EDB CFM	EWB °F (°C)	Total	Integ	Total	Integ	Total	Integ	Total	Integ	Total	Integ	Total	Integ	Total	Integ	Total	Integ	Total	Integ	Total	Integ	Total	Integ	Total	Integ
		65 (18.3)	1050	11.29	10.39	2.23	14.77	13.59	2.33	18.36	16.85	2.42	22.15	20.09	2.51	26.29	23.04	2.61	31.12	31.12	2.74	36.45	36.45	2.89	43.29
1200	11.49		10.57	2.25	14.97	13.78	2.33	18.58	17.05	2.41	22.39	20.30	2.48	26.60	23.31	2.57	31.43	31.43	2.68	37.07	37.07	2.82	43.51	43.51	2.98
1350	11.66		10.72	2.26	15.15	13.94	2.34	18.77	17.23	2.40	22.59	20.49	2.47	26.87	23.54	2.55	31.76	31.76	2.64	37.79	37.79	2.77	42.96	42.96	2.92
70 (21.1)	1050	10.75	9.89	2.33	14.33	13.18	2.43	17.99	16.51	2.53	21.82	19.79	2.64	25.90	22.70	2.74	30.63	30.63	2.88	35.89	35.89	3.03	42.54	42.54	3.25
	1200	10.95	10.08	2.34	14.54	13.38	2.43	18.22	16.72	2.52	22.06	20.01	2.61	26.21	22.96	2.70	31.01	31.01	2.82	36.42	36.42	2.96	43.07	43.07	3.13
	1350	11.13	10.24	2.35	14.72	13.55	2.44	18.41	16.90	2.52	22.27	20.20	2.60	26.47	23.19	2.68	31.48	31.48	2.78	37.12	37.12	2.91	42.78	42.78	3.06
75 (23.9)	1050	10.16	9.34	2.42	13.83	12.73	2.54	17.57	16.13	2.65	21.46	19.46	2.76	25.55	22.39	2.88	30.22	30.22	3.02	35.36	35.36	3.18	41.76	41.76	3.40
	1200	10.36	9.53	2.43	14.06	12.94	2.54	17.81	16.35	2.64	21.71	19.69	2.74	25.83	22.63	2.84	30.58	30.58	2.96	35.87	35.87	3.10	42.56	42.56	3.29
	1350	10.53	9.69	2.45	14.25	13.11	2.55	18.01	16.53	2.64	21.92	19.88	2.72	26.07	22.84	2.81	30.89	30.89	2.92	36.37	36.37	3.05	42.48	42.48	3.21

PERFORMANCE DATA-STANDARD X-13 INDOOR MOTOR

PHN442 Cooling Extended Performance Table

EVAPORATOR AIR CFM / EWB BF		75 (23.9)		85 (29.4)		95 (35)		105 (40.6)		115 (46.1)		125 (51.7)	
		Capacity MBtuh		Capacity MBtuh		Capacity MBtuh		Capacity MBtuh		Capacity MBtuh		Capacity MBtuh	
		Total	Sens	Total	Sens	Total	Sens	Total	Sens	Total	Sens	Total	Sens
1225 / 0.19	57 (13.9)	39.54	39.54	37.86	37.86	36.04	36.04	34.09	34.09	33.27	33.27	31.64	31.64
	62 (16.7)	41.07	37.14	35.92	2.99	36.93	34.59	34.67	33.19	33.74	32.57	29.46	29.46
	63* (17.2)	41.31	30.04	28.92	2.99	37.09	27.93	34.77	26.46	33.77	25.92	23.46	23.46
	67 (19.4)	44.64	31.32	30.19	3.03	40.10	28.99	37.58	27.69	36.64	27.22	24.59	24.59
	72 (22.2)	48.47	25.70	24.64	3.07	43.49	23.53	40.72	22.32	39.79	21.91	19.42	19.42
	77 (22.2)	50.59	27.89	26.72	3.18	45.17	25.51	42.14	24.18	41.29	23.80	21.00	21.00
1400 / 0.21	57 (13.9)	41.22	39.41	39.41	3.03	37.47	37.47	35.37	35.37	34.56	34.56	33.33	33.33
	62 (16.7)	42.17	39.64	40.08	3.04	37.89	36.85	35.52	35.52	34.66	34.66	33.34	33.34
	63* (17.2)	42.96	31.75	30.57	3.04	37.94	29.32	35.51	27.98	34.52	27.44	24.80	24.80
	67 (19.4)	45.76	33.17	31.97	3.08	41.00	30.70	38.36	29.32	37.43	28.87	26.08	26.08
	72 (22.2)	49.65	26.83	25.72	3.13	44.43	24.56	41.52	23.28	40.63	22.89	20.24	20.24
	77 (22.2)	50.59	27.89	26.72	3.18	45.17	25.51	42.14	24.18	41.29	23.80	21.00	21.00
1575 / 0.23	57 (13.9)	42.65	42.65	40.73	3.09	38.67	38.67	36.45	36.45	35.65	35.65	34.33	34.33
	62 (16.7)	43.14	41.90	40.94	3.09	38.75	38.75	36.45	36.45	35.65	35.65	34.33	34.33
	63* (17.2)	43.20	33.36	32.13	3.09	38.61	30.82	36.08	29.41	35.10	28.88	26.10	26.10
	67 (19.4)	46.66	34.92	33.67	3.13	41.71	32.33	38.97	30.89	38.06	30.44	27.49	27.49
	72 (22.2)	50.59	27.89	26.72	3.18	45.17	25.51	42.14	24.18	41.29	23.80	21.00	21.00
	77 (22.2)	50.59	27.89	26.72	3.18	45.17	25.51	42.14	24.18	41.29	23.80	21.00	21.00

*At 75°F (23.9 °C) entering dry bulb—Tennessee Valley Authority [TVA] rating conditions; all others at 80°F (26.7 °C) entering dry bulb. See Legend and Notes.

PHN442 Heating Extended Performance Table

INDOOR AIR EDB CFM		-10 (-23.3)		0 (-17.8)		10 (-12.2)		20 (-6.7)		30 (-1.1)		40 (4.4)		50 (10)		60 (15.6)	
		Capacity MBtuh		Capacity MBtuh		Capacity MBtuh		Capacity MBtuh		Capacity MBtuh		Capacity MBtuh		Capacity MBtuh		Capacity MBtuh	
		Total	Integ	Total	Integ	Total	Integ	Total	Integ	Total	Integ	Total	Integ	Total	Integ	Total	Integ
65 (18.3)	1225	13.75	12.65	2.45	17.57	16.17	2.56	21.58	19.81	2.68	25.83	23.43	2.96	36.10	32.45	3.36	50.07
	1400	13.97	12.85	2.47	17.81	16.38	2.57	21.83	20.04	2.68	26.10	23.67	2.92	36.56	32.9	3.29	50.69
	1575	14.17	13.03	2.49	18.01	16.57	2.58	22.05	20.23	2.68	26.32	23.87	2.90	36.94	32.6	3.26	50.61
70 (21.1)	1225	13.24	12.18	2.57	17.15	15.78	2.70	21.21	19.47	2.82	25.49	23.12	3.11	35.59	31.83	3.53	49.28
	1400	13.47	12.39	2.59	17.39	16.00	2.70	21.46	19.70	2.82	25.76	23.37	3.07	36.03	32.4	3.45	50.08
	1575	13.67	12.57	2.61	17.60	16.19	2.72	21.68	19.90	2.82	26.00	23.58	3.05	36.40	32.1	3.41	50.18
75 (23.9)	1225	12.69	11.67	2.69	16.68	15.35	2.83	20.80	19.09	2.97	25.13	22.79	3.28	35.10	31.7	3.71	48.53
	1400	12.91	11.88	2.71	16.93	15.57	2.84	21.07	19.34	2.96	25.41	23.04	3.24	35.53	31.4	3.63	49.30
	1575	13.12	12.07	2.74	17.14	15.77	2.85	21.29	19.54	2.97	25.65	23.26	3.21	35.88	31.7	3.58	49.68

PERFORMANCE DATA-STANDARD X-13 INDOOR MOTOR

PHN448 Cooling Extended Performance Table

EVAPORATOR AIR CFM / EWB BF		CONDENSER ENTERING AIR TEMPERATURES °F (°C)																	
		75 (23.9)			85 (29.4)			95 (35)			105 (40.6)			115 (46.1)			125 (51.7)		
		Capacity MBtuh	Total Sys KW		Capacity MBtuh	Total Sys KW		Capacity MBtuh	Total Sys KW		Capacity MBtuh	Total Sys KW		Capacity MBtuh	Total Sys KW		Capacity MBtuh	Total Sys KW	
57 (13.9)	48.07	48.07	2.99	44.60	44.60	3.35	41.11	41.11	3.74	37.59	37.59	4.18	33.97	33.97	4.66	30.20	30.20	5.18	
62 (16.7)	49.24	49.24	3.00	45.38	40.81	3.35	41.54	38.58	3.75	37.68	37.68	4.18	33.97	33.97	4.66	30.20	30.20	5.18	
63* (17.2)	49.85	34.74	3.00	45.89	32.91	3.35	41.92	31.03	3.75	37.95	29.14	4.18	33.92	27.18	4.66	29.77	25.09	5.17	
67 (19.4)	53.72	36.13	3.02	49.45	34.25	3.38	45.16	32.34	3.77	40.85	30.39	4.21	36.48	28.37	4.68	31.96	26.23	5.20	
72 (22.2)	58.70	29.21	3.05	54.00	27.52	3.41	49.26	25.79	3.80	44.53	24.03	4.24	39.71	22.21	4.72	34.74	20.27	5.23	
57 (13.9)	50.08	50.08	3.05	46.40	46.40	3.41	42.70	42.70	3.81	38.95	38.95	4.25	35.11	35.11	4.72	31.11	31.11	5.24	
62 (16.7)	50.54	45.92	3.06	46.59	43.48	3.41	42.71	42.71	3.81	38.95	38.95	4.25	35.11	35.11	4.72	31.11	31.11	5.24	
63* (17.2)	50.98	36.96	3.06	46.86	35.03	3.41	42.75	33.06	3.81	38.62	31.05	4.24	34.44	28.96	4.72	30.16	26.75	5.23	
67 (19.4)	54.90	38.50	3.08	50.46	36.52	3.44	46.00	34.50	3.83	41.53	32.45	4.27	37.00	30.30	4.74	32.34	28.01	5.26	
72 (22.2)	59.95	30.65	3.11	55.05	28.88	3.47	50.14	27.08	3.86	45.24	25.24	4.30	40.25	23.33	4.77	35.12	21.31	5.28	
57 (13.9)	51.77	51.77	3.11	47.91	47.91	3.47	44.01	44.01	3.87	40.06	40.06	4.31	36.03	36.03	4.79	31.82	31.82	5.30	
62 (16.7)	51.79	51.79	3.11	47.91	47.91	3.47	44.02	44.02	3.87	40.06	40.06	4.31	36.03	36.03	4.79	31.82	31.82	5.30	
63* (17.2)	51.85	39.08	3.11	47.61	37.05	3.47	43.38	34.99	3.87	39.13	32.86	4.30	34.84	30.64	4.78	30.46	28.24	5.29	
67 (19.4)	55.81	40.79	3.14	51.24	38.71	3.50	46.63	36.58	3.89	42.04	34.40	4.33	37.39	32.12	4.80	32.61	29.67	5.31	
72 (22.2)	60.91	32.02	3.17	55.86	30.17	3.53	50.80	28.29	3.92	45.76	26.38	4.36	40.65	24.40	4.83	35.38	22.30	5.34	

*At 75°F (23.9 °C) entering dry bulb—Tennessee Valley Authority [TVA] rating conditions; all others at 80°F (26.7 °C) entering dry bulb. See Legend and Notes.

PHN448 Heating Extended Performance Table

INDOOR AIR EDB CFM		OUTDOOR COIL ENTERING AIR TEMPERATURES °F (°C)																							
		-10 (-23.3)			0 (-17.8)			10 (-12.2)			20 (-6.7)			30 (-1.1)			40 (4.4)			50 (10)			60 (15.6)		
		Capacity MBtuh	Total Sys KW		Capacity MBtuh	Total Sys KW		Capacity MBtuh	Total Sys KW		Capacity MBtuh	Total Sys KW		Capacity MBtuh	Total Sys KW		Capacity MBtuh	Total Sys KW		Capacity MBtuh	Total Sys KW		Capacity MBtuh	Total Sys KW	
1400	15.21	14.00	3.19	19.74	18.16	3.29	24.43	22.43	3.40	29.38	26.64	3.51	34.68	30.38	3.63	40.60	40.60	3.78	47.66	47.66	3.97	55.91	55.91	4.22	
1600	15.51	14.27	3.22	20.06	18.45	3.31	24.77	22.74	3.40	29.73	26.97	3.50	35.08	30.74	3.61	41.18	41.18	3.74	48.35	48.35	3.90	57.32	57.32	4.12	
1800	15.79	14.52	3.26	20.34	18.71	3.35	25.07	23.01	3.42	30.04	27.25	3.51	35.44	31.05	3.60	41.70	41.70	3.72	48.93	48.93	3.87	57.75	57.75	4.06	
1400	14.51	13.35	3.32	19.15	17.62	3.44	23.92	21.96	3.56	28.91	26.22	3.68	34.20	29.97	3.81	39.99	39.99	3.97	46.96	46.96	4.17	55.04	55.04	4.42	
1600	14.81	13.63	3.36	19.47	17.92	3.46	24.26	22.27	3.57	29.28	26.55	3.67	34.61	30.33	3.79	40.53	40.53	3.92	47.63	47.63	4.09	56.25	56.25	4.32	
1800	15.09	13.88	3.40	19.76	18.18	3.50	24.57	22.55	3.59	29.60	26.84	3.68	34.97	30.64	3.78	40.99	40.99	3.90	48.19	48.19	4.06	57.10	57.10	4.25	
1400	13.74	12.64	3.46	18.50	17.02	3.59	23.36	21.44	3.72	28.41	25.77	3.86	33.71	29.54	4.00	39.42	39.42	4.16	46.29	46.29	4.37	54.20	54.20	4.63	
1600	14.04	12.92	3.49	18.83	17.32	3.62	23.71	21.77	3.73	28.79	26.11	3.85	34.13	29.90	3.97	39.91	39.91	4.11	46.93	46.93	4.29	55.09	55.09	4.52	
1800	14.32	13.17	3.54	19.12	17.59	3.65	24.02	22.05	3.75	29.12	26.41	3.85	34.49	30.22	3.96	40.36	40.36	4.08	47.48	47.48	4.25	56.24	56.24	4.46	

PERFORMANCE DATA-STANDARD X-13 INDOOR MOTOR

PHN460 Cooling Extended Performance Table

EVAPORATOR AIR		CONDENSER ENTERING AIR TEMPERATURES °F (°C)																	
		75 (23.9)			85 (29.4)			95 (35)			105 (40.6)			115 (46.1)			125 (51.7)		
		CFM / BF	EWB °F (°C)	Capacity MBtuh	Total Sys KW	Capacity MBtuh	Total Sys KW	Capacity MBtuh	Total Sys KW	Capacity MBtuh	Total Sys KW	Capacity MBtuh	Total Sys KW	Capacity MBtuh	Total Sys KW	Capacity MBtuh	Total Sys KW		
1750 / 0.07	57 (13.9)	63.53	63.53	3.78	58.78	58.78	4.29	53.97	53.97	4.86	49.09	49.09	5.49	44.01	44.01	6.19	42.42	42.42	6.41
	62 (16.7)	65.04	65.04	3.79	59.74	59.74	4.30	54.44	54.44	4.86	49.15	49.15	5.50	44.01	44.01	6.19	38.66	38.66	6.95
	63* (17.2)	65.92	65.92	3.80	60.47	60.47	4.31	54.99	54.99	4.87	49.48	49.48	5.50	43.83	43.83	6.19	42.07	42.07	6.40
	67 (19.4)	70.86	70.86	3.85	64.96	64.96	4.35	59.00	59.00	4.92	52.98	52.98	5.54	46.84	46.84	6.23	40.50	40.50	6.98
	72 (22.2)	77.33	77.33	3.90	70.80	70.80	4.41	64.19	64.19	4.98	57.55	57.55	5.60	50.77	50.77	6.29	43.78	43.78	7.03
2000 / 0.08	57 (13.9)	66.05	66.05	3.88	61.00	61.00	4.40	55.88	55.88	4.97	50.65	50.65	5.60	45.26	45.26	6.30	39.58	39.58	7.06
	62 (16.7)	66.61	66.61	3.89	61.13	61.13	4.40	55.88	55.88	4.97	50.66	50.66	5.60	45.25	45.25	6.30	39.57	39.57	7.06
	63* (17.2)	67.26	67.26	3.89	61.59	61.59	4.40	55.88	55.88	4.97	50.16	50.16	5.59	44.32	44.32	6.29	38.33	38.33	7.04
	67 (19.4)	72.23	72.23	3.94	66.09	66.09	4.45	59.87	59.87	4.41	53.63	53.63	5.64	47.29	47.29	6.33	40.75	40.75	7.08
	72 (22.2)	78.76	78.76	3.94	71.95	71.95	4.51	65.10	65.10	5.07	58.23	58.23	5.70	51.25	51.25	6.38	44.04	44.04	7.12
2250 / 0.09	57 (13.9)	68.16	68.16	3.98	62.83	62.83	4.50	57.41	57.41	5.07	51.90	51.90	5.70	46.22	46.22	6.40	40.27	40.27	7.16
	62 (16.7)	68.17	68.17	3.98	62.83	62.83	4.50	57.41	57.41	5.07	51.90	51.90	5.71	46.22	46.22	6.40	40.27	40.27	7.16
	63* (17.2)	68.27	68.27	3.98	62.41	62.41	4.49	56.54	56.54	5.06	50.64	50.64	5.69	44.66	44.66	6.38	38.53	38.53	7.13
	67 (19.4)	73.27	73.27	4.03	66.92	66.92	4.54	60.50	60.50	4.67	54.10	54.10	5.73	47.60	47.60	6.42	40.92	40.92	7.17
	72 (22.2)	79.84	79.84	4.09	72.79	72.79	4.60	65.73	65.73	5.16	58.70	58.70	5.79	51.53	51.53	6.48	44.15	44.15	7.22

*At 75°F (23.9 °C) entering dry bulb—Tennessee Valley Authority [TVA] rating conditions; all others at 80°F (26.7 °C) entering dry bulb. See Legend and Notes.

PHN460 Heating Extended Performance Table

INDOOR AIR		OUTDOOR COIL ENTERING AIR TEMPERATURES °F (°C)																							
		-10 (-17.3)			0 (-17.8)			10 (-12.2)			20 (-6.7)			30 (-1.1)			40 (4.4)			50 (10)			60 (15.6)		
		EDB CFM	Capacity MBtuh	Total Sys KW	Capacity MBtuh	Total Sys KW	Capacity MBtuh	Total Sys KW	Capacity MBtuh	Total Sys KW	Capacity MBtuh	Total Sys KW	Capacity MBtuh	Total Sys KW	Capacity MBtuh	Total Sys KW	Capacity MBtuh	Total Sys KW	Capacity MBtuh	Total Sys KW					
65 (18.3)	1750	21.44	19.72	3.85	27.02	24.86	3.97	32.88	30.18	4.09	39.13	35.49	4.23	46.15	40.44	4.40	54.26	54.26	4.61	63.98	63.98	4.86	74.82	74.82	5.16
	2000	21.85	20.11	3.90	27.45	25.26	4.01	33.33	30.60	4.12	39.63	35.94	4.24	46.77	40.98	4.38	55.02	55.02	4.56	65.19	65.19	4.78	74.99	74.99	5.04
	2250	22.24	20.46	3.97	27.85	25.63	4.06	33.75	30.98	4.15	40.07	36.34	4.26	47.32	41.46	4.39	56.12	56.12	4.56	65.29	65.29	4.75	73.80	73.80	4.99
70 (21.1)	1750	20.75	19.09	4.03	26.44	24.33	4.16	32.38	29.72	4.30	38.64	35.04	4.45	45.62	39.97	4.62	53.55	53.55	4.84	62.76	62.76	5.10	73.96	73.96	5.41
	2000	21.17	19.48	4.09	26.88	24.73	4.20	32.84	30.14	4.32	39.14	35.50	4.45	46.18	40.46	4.60	54.29	54.29	4.79	64.31	64.31	5.02	74.39	74.39	5.29
	2250	21.56	19.84	4.15	27.28	25.11	4.25	33.25	30.52	4.36	39.59	35.91	4.47	46.68	40.90	4.61	54.93	54.93	4.78	64.77	64.77	4.98	73.71	73.71	5.23
75 (23.9)	1750	20.00	18.40	4.22	25.80	23.74	4.36	31.83	29.21	4.51	38.15	34.60	4.68	45.07	39.49	4.86	52.71	52.71	5.07	61.83	61.83	5.35	73.09	73.09	5.68
	2000	20.42	18.79	4.28	26.26	24.16	4.40	32.30	29.64	4.53	38.62	35.03	4.67	45.64	39.99	4.83	53.58	53.58	5.03	63.19	63.19	5.27	73.64	73.64	5.54
	2250	20.82	19.15	4.34	26.67	24.54	4.46	32.73	30.04	4.57	39.07	35.43	4.69	46.14	40.43	4.84	54.20	54.20	5.01	64.17	64.17	5.22	73.39	73.39	5.47

LEGEND

- Bypass Factor
- Entering Dry – Bulb
- Entering Wet – Bulb
- Total Unit Power Input
- Sensible Heat Capacity (1000 Btuh)
- Total Capacity (1 000 Btuh) (net)
- Relative Humidity

COOLING NOTES:

1. Ratings are net; they account for the effects of the evaporator—fan motor power and heat.
2. Direct interpolation is permissible. Do not extrapolate.
3. The following formulas may be used:

$$t_{ldb} = t_{edb} - \frac{\text{Sensible capacity (Btuh)}}{1.10 \times \text{cfm}}$$

$$t_{lwb} = \text{Wet-bulb temperature corresponding to enthalpy air leaving evaporator coil (} t_{lwb} \text{)} = h_{lwb} - \frac{\text{total capacity (Btuh)}}{4.5 \times \text{cfm}}$$

Where: h_{lwb} = Enthalpy of air entering evaporator coil

4. The SHC is based on 80°F (26.7 °C) edb temperature of air entering evaporator coil. Below 80°F (26.7° C) edb, subtract (corr factor x cfm) from SHC. Above 80°F (26.7° C) edb, add (corr factor x cfm) to SHC. Correction Factor = 1.10 x (1 + BF) x (edb + 80).
5. Integrated capacity is maximum (instantaneous) capacity less the effect of frost on the outdoor coil and the heat required to defrost it.

ACCESSORIES

ROOF CURBS

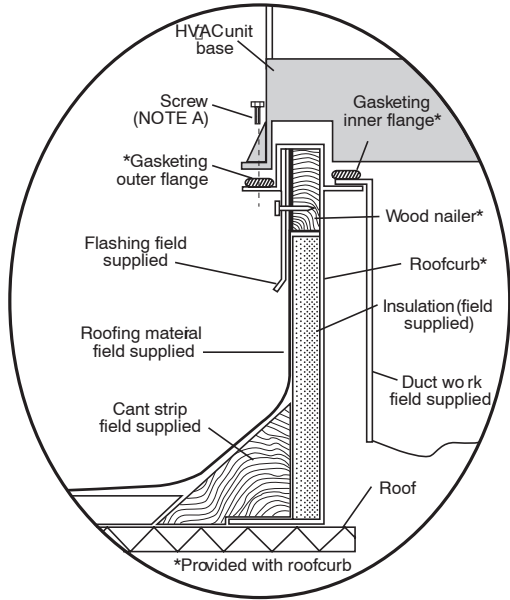

Roof Curb for Small Cabinet

Note A: When unit mounting screw is used, retainer bracket must also be used.

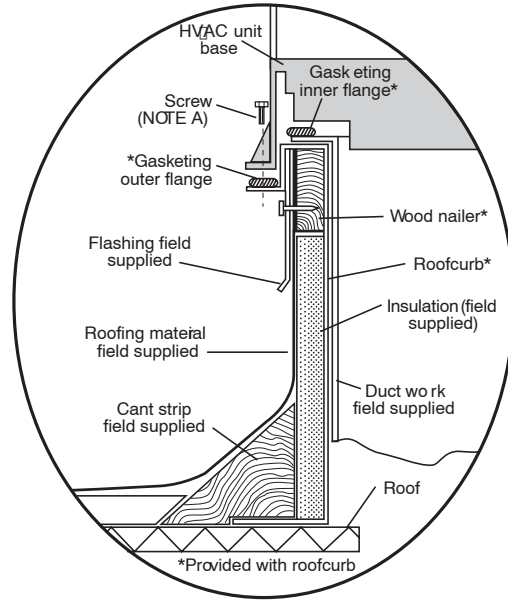

Roof Curb for Large Cabinet

Note A: When unit mounting screw is used, retainer bracket must also be used.

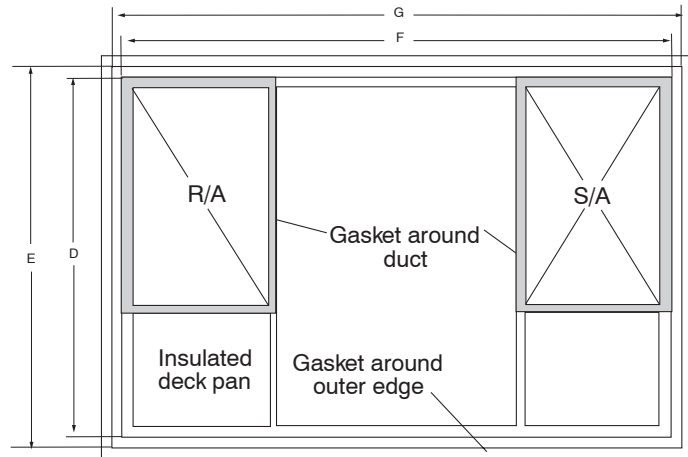
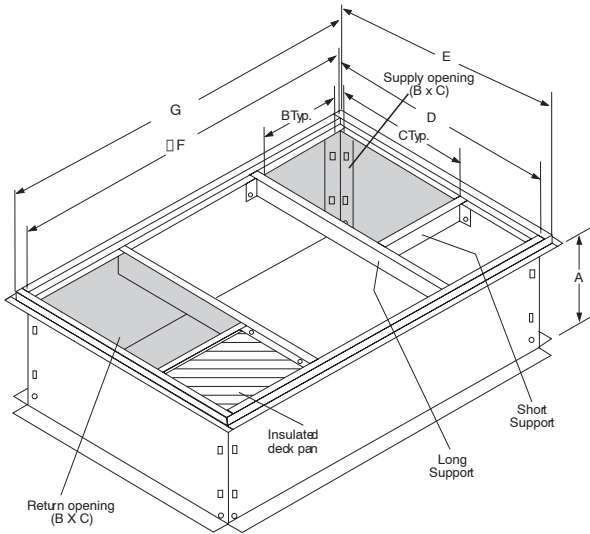

UNIT SIZE	MODEL NUMBER	A IN. [MM]	B IN. [MM]	C IN. [MM]	D IN. [MM]	E IN. [MM]	F IN. [MM]	G IN. [MM]
24, 30	NPRFCURB006A00	8 [203]	11 [279]	16-1/2 [419]	28-3/4 [730]	30-3/8 [771]	44-5/16 [1126]	45-15/16 [1167]
	NPRFCURB007A00	14 [356]	11 [279]	16-1/2 [419]	28-3/4 [730]	30-3/8 [771]	44-5/16 [1126]	45-15/16 [1167]
36, 42, 48, 60	NPRFCURB008A00	8 [203]	16-3/16 [411]	17-3/8 [441]	40-1/4 [1022]	41-15/16 [1065]	44-7/16 [1129]	46-1/16 [1169]
	NPRFCURB009A00	14 [356]	16-3/16 [411]	17-3/8 [441]	40-1/4 [1022]	41-15/16 [1065]	44-7/16 [1129]	46-1/16 [1169]

Notes:

1. Seal strip must be applied as required to unit being installed.
2. Roof curb is made of 16 gauge steel.
3. Attach ductwork to curb (flanges of duct rest on curb).
4. Insulated panels: 1-in. thick fiberglass 1 lb. density.
5. When unit mounting screw is used (see Note A), a retainer bracket must be used as well. This bracket must also be used when required by code for hurricane or seismic conditions. This bracket is available through Micrometl.

SPECIFICATIONS SUBJECT TO CHANGE WITHOUT NOTICE

ACCESSORIES (continued)

ECONOMIZERS (ALL FULLY MODULATING)

Part Number	Application	Control	Use With Model Size
NPECOMZR003A00	Horizontal, convertible to Downflow	Dry Bulb (Enthalpy Control optional)	24, 30
NPECOMZR004A00			36, 42
NPECOMZR006A00			48, 60

All Economizers include Filter Racks but do not include filters.

MANUAL FRESH AIR DAMPERS (use in DOWNFLOW application only) *

Model Number	Control	Use With Model Size
NPMANDPR004A00	Manual	24, 30
NPMANDPR005A00		36, 42
NPMANDPR006A00		48, 60

* Unit must have internal filters to protect evaporator coil when Fresh Air Damper is installed.
All Manual Fresh Air Dampers shipped with Filter Racks but without Filters.

FILTER RACK and FILTER (shipped with 1" filters)

Model Number	Application	Filter Size	Use With Model Size
NPFILTRK004A00	Horizontal or Downflow	12" x 20" x 1" (quan. 2) or 12" x 20" x 2" (quan. 1) PLUS 10" x 20" x 2" (quan.1)	24, 30
NPFILTRK005A00		12" x 24" x 1" or 2" (3 required)	36, 42
NPFILTRK006A00		12" x 24" x 1" or 2" (3 required)	48, 60

CONCENTRIC DIFFUSER - Fits 2' x 4' Drop Ceiling Grid

Model Number	Description	Use With Model Size
AXB030CSA	STEP DOWN - Adapts round duct (18" dia.) to ceiling diffuser	ALL
AXB030CFA	FLUSH MOUNT - Adapts round duct (18" dia.) to ceiling diffuser	ALL

SQUARE to ROUND TRANSITION (Set of 2) - Use With Curb

Model Number	Round Size	Square Size	Use With Model Size
NPDUCLG002A00	14"	14" x 16"	ALL

PTC COMPRESSOR START ASSIST KIT

Model Number	Description	Use With Model Size
NPHSTART001A00	PTC type compressor start assist	ALL

LIFTING / RIGGING KIT

Model Number	Description	Use With Model Size
NPLIFTBK003A10	Lifting / Rigging Kit (Set of 10)	ALL

UNIT DIMENSIONS, model sizes 24, 30

REQUIRED CLEARANCES TO COMBUSTIBLE MATL.

TOP OF UNIT	14.60 [385.6]
DUCT SIDE OF UNIT	2.00 [50.8]
SIDE OPPOSITE DUCTS	14.00 [355.6]
BOTTOM OF UNIT	0.0 [0.0]
FLUE PANEL	36.00 [914.4]

NEC REQUIRED CLEARANCES

BETWEEN UNITS, POWER ENTRY SIDE	42.00 [1066.8]
UNIT AND UNGROUNDED SURFACES, POWER ENTRY SIDE	36.00 [914.4]
UNIT AND BLOCK OR CONCRETE WALLS AND OTHER GROUNDED SURFACES, POWER ENTRY SIDE	42.00 [1066.8]

REQUIRED CLEARANCE FOR OPERATION AND SERVICING

EVAP. COIL ACCESS SIDE	36.00 [914.4]
POWER ENTRY SIDE	42.00 [1066.8]
ELECT. FOR NEC REQUIREMENTS	42.00 [1066.8]
UNIT TOP	48.00 [1219.2]
SIDE OPPOSITE DUCTS	36.00 [914.0]
DUCT PANEL	12.00 [304.8]

*MINIMUM DISTANCES: UNIT IS PLACED LESS THAN 12.00 [304.8] FROM WALL SYSTEM, THEN SYSTEM PERFORMANCE MAY BE COMPROMISED.

DIMENSIONS IN () ARE IN MILLIMETERS

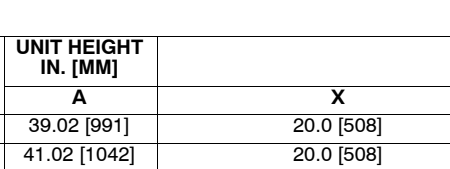
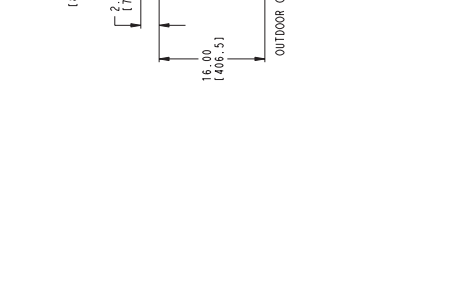
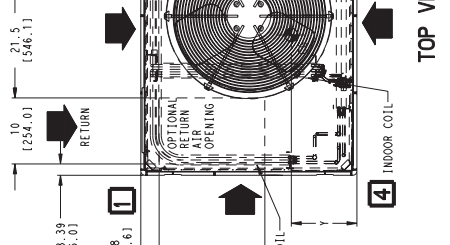
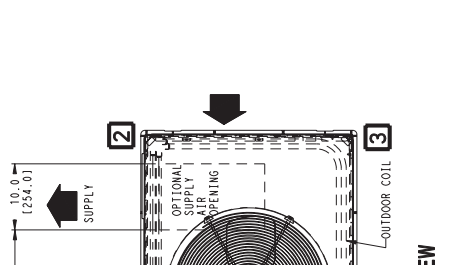
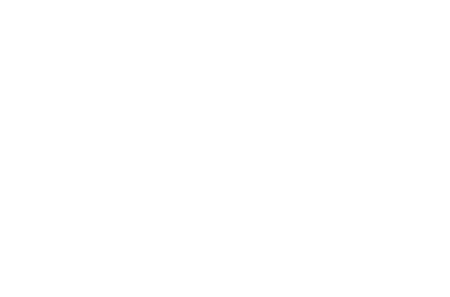

REQUIRED CLEARANCES TO COMBUSTIBLE MATL.

TOP OF UNIT	14.60 [385.6]
DUCT SIDE OF UNIT	2.00 [50.8]
SIDE OPPOSITE DUCTS	14.00 [355.6]
BOTTOM OF UNIT	0.0 [0.0]
FLUE PANEL	36.00 [914.4]

NEC REQUIRED CLEARANCES

BETWEEN UNITS, POWER ENTRY SIDE	42.00 [1066.8]
UNIT AND UNGROUNDED SURFACES, POWER ENTRY SIDE	36.00 [914.4]
UNIT AND BLOCK OR CONCRETE WALLS AND OTHER GROUNDED SURFACES, POWER ENTRY SIDE	42.00 [1066.8]

REQUIRED CLEARANCE FOR OPERATION AND SERVICING

EVAP. COIL ACCESS SIDE	36.00 [914.4]
POWER ENTRY SIDE	42.00 [1066.8]
ELECT. FOR NEC REQUIREMENTS	42.00 [1066.8]
UNIT TOP	48.00 [1219.2]
SIDE OPPOSITE DUCTS	36.00 [914.0]
DUCT PANEL	12.00 [304.8]

*MINIMUM DISTANCES: UNIT IS PLACED LESS THAN 12.00 [304.8] FROM WALL SYSTEM, THEN SYSTEM PERFORMANCE MAY BE COMPROMISED.

DIMENSIONS IN () ARE IN MILLIMETERS

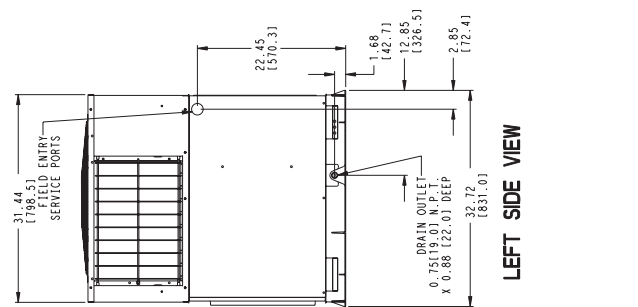
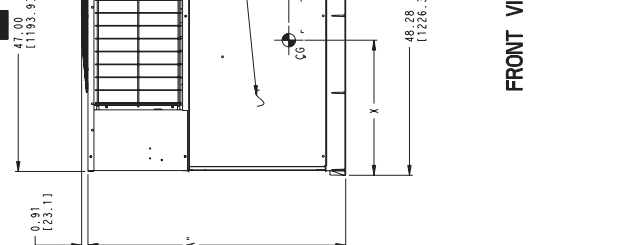
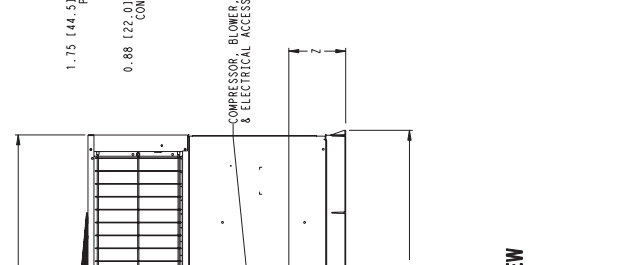
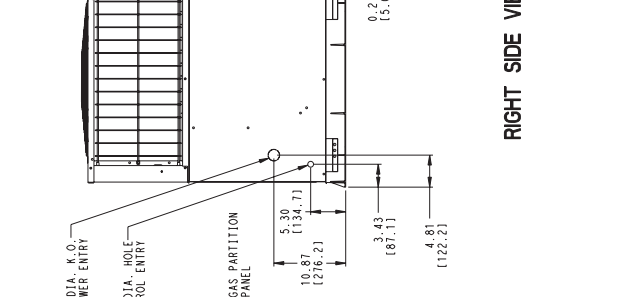

CENTER OF GRAVITY IN. [MM]

Model Size	UNIT HEIGHT IN. [MM]	CENTER OF GRAVITY IN. [MM]		
	A	X	Y	Z
24	39.02 [991]	20.0 [508]	19.3 [490]	17.6 [447]
30	41.02 [1042]	20.0 [508]	14.0 [356]	13.0 [330]

50VT500169 REV 2.0

UNIT DIMENSIONS, model sizes 36, 42, 48, 60

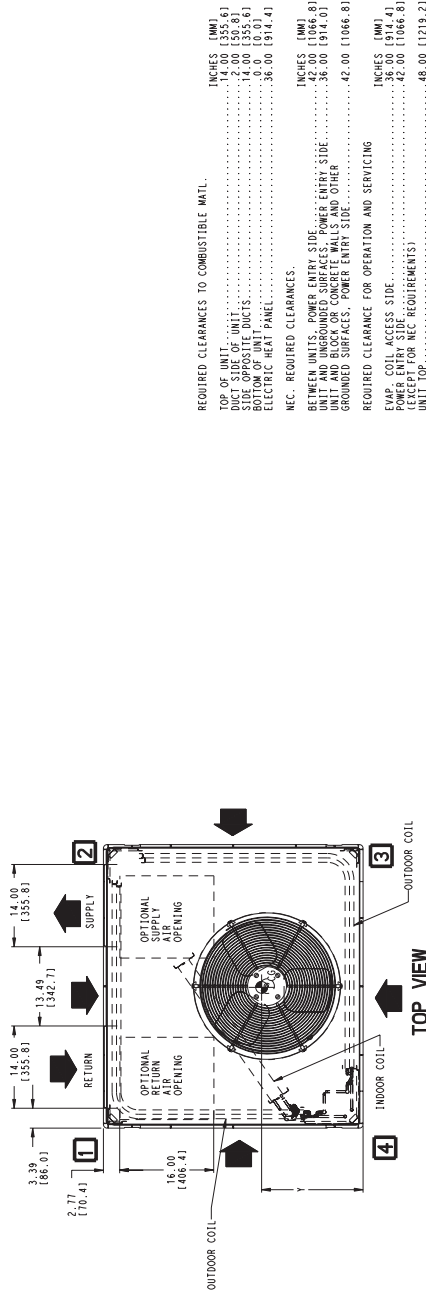

REQUIRED CLEARANCES TO COMBUSTIBLE MATL.

INCHES (MM)

TOP OF UNIT.....14.00 [355.8]

DUCT SIDE OF UNIT.....2.00 [50.8]

OUTDOOR COIL DUCTS.....6.00 [152.4]

INDOOR COIL DUCTS.....6.00 [152.4]

ELECTRIC HEAT PANEL.....36.00 [914.4]

MFC. REQUIRED CLEARANCES.

INCHES (MM)

BETWEEN UNITS, POWER ENTRY SIDE.....42.00 [1066.8]

UNIT AND BLOCK OR CONCRETE WALLS AND OTHER GROUNDED SURFACES, POWER ENTRY SIDE.....42.00 [1066.8]

REQUIRED CLEARANCE FOR OPERATION AND SERVICING

INCHES (MM)

SWAP COIL ACCESS SIDE.....36.00 [914.4]

POWER ENTRY SIDE.....42.00 [1066.8]

FIELD ENTRY SERVICE PORT (EXCEPT FOR NEC REQUIREMENTS).....42.00 [1066.8]

DUCT OPPOSITE DUCTS.....48.00 [1219.2]

DUCT PANEL.....12.00 [304.8]

MINIMUM DISTANCES: IF UNIT IS PLACED LESS THAN 12.00 (304.8) FROM WALL SYSTEM, THEN SYSTEM PERFORMANCE MAY BE COMPROMISED.

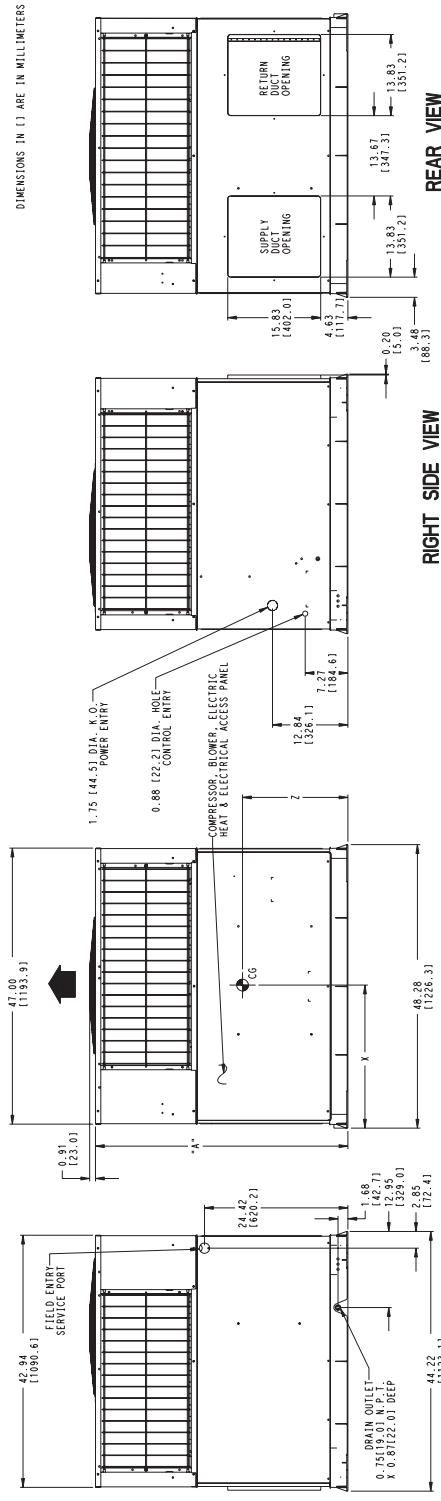

REV 2.0
50VT500170

Model Size	UNIT HEIGHT	CENTER OF GRAVITY			
	IN. [MM]	A	X	Y	Z
36	42.98 [1092]		21.0 [533]	21.5 [520]	16.6 [422]
42	46.98 [1193]		21.0 [533]	21.5 [520]	17.1 [434]
48	46.98 [1193]		21.0 [533]	20.0 [508]	17.4 [442]
60	46.98 [1193]		21.0 [533]	20.0 [508]	17.6 [447]

GUIDE SPECIFICATIONS

CABINET

Unit cabinet shall be constructed of phosphated, zinc-coated, pre-painted steel capable of with-standing 500 hours in salt spray. Normal service shall be through a single removable cabinet panel.

The unit shall be constructed on a rust proof unit base that has an externally trapped, integrated sloped drain.

Evaporator fan compartment top surface shall be insulated with a minimum 1/2-in. thick, flexible fiberglass insulation, coated on the air side and retained by adhesive and mechanical means. The evaporator wall sections will be insulated with a minimum semi-rigid foil-faced board capable of being wiped clean. Aluminum foil-faced fiberglass insulation shall be used in the entire indoor air cavity section.

COOLING SECTION

The unit is factory charged and operationally ready upon delivery. The unit refrigerant circuit has a high efficiency scroll compressor with internal overload protection, and copper tube / aluminum fin evaporator and condenser coils. The unit is designed for cooling operation to 40° F and will be capable of being wired for field installed economizer type accessories.

COILS

The evaporator and condenser coils are fabricated with aluminum fins mechanically bonded to copper tubing. Both coils are pressure tested prior to assembly into the unit and electronically leak tested after assembly into the unit.

CONDENSER FAN

The unit has a single direct-drive propeller-fan / motor assembly. The assembly is mounted directly to a vertical-discharge grille that is easily removed for service. Motors are 825 or 1100 RPM with sleeve or ball bearings and internal overload protection.

EVAPORATOR BLOWER

All units have a direct-drive X-13 evaporator blower motor as a standard. The direct-drive evaporator blower motor has sleeve bearings and internal overload protection.

CORNER WEIGHTS and RIGGING DETAILS

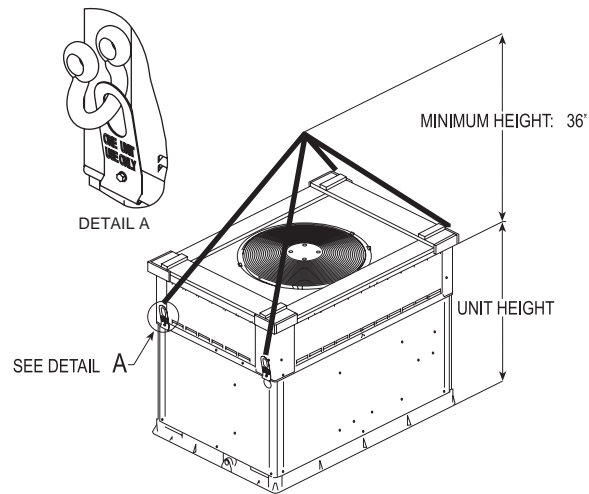
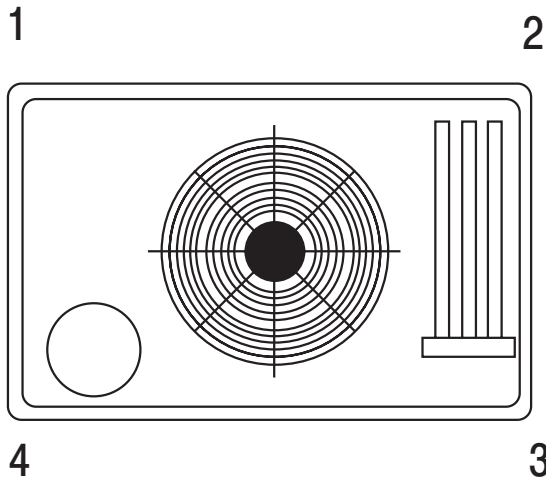

C00070b

A06361

Corner Weights (Small Cabinet) Lbs. (kg)			Corner Weights (Large Cabinet) Lbs. (kg)				
Model Size	24	30	Model Size	36	42	48	60
Total Weight	306 (139)	316 (143)	Total Weight	371 (168)	412 (187)	432 (196)	462 (210)
Corner Weight 1	61 (28)	63 (29)	Corner Weight 1	74 (34)	82 (37)	86 (39)	92 (42)
Corner Weight 2	49 (22)	51 (23)	Corner Weight 2	59 (27)	66 (30)	69 (31)	74 (34)
Corner Weight 3	73 (33)	76 (34)	Corner Weight 3	89 (40)	99 (45)	104 (47)	111 (50)
Corner Weight 4	122 (56)	126 (57)	Corner Weight 4	148 (67)	165 (75)	173 (78)	185 (84)
Rigging Weight	317 (144)	327 (148)	Rigging Weight	382 (173)	427 (164)	447 (203)	477 (216)
Shipping Weight	354 (171)	364 (165)	Shipping Weight	419 (190)	464 (210)	484 (220)	514 (233)

MODEL NOMENCLATURE										
MODEL SERIES	P	H	N	4	36	000	K	00	A	1
P = Package										
H = Heat Pump										
N = R-410A										
4 = 14										
24 = 24,000 BTUH = 2 Tons										
30 = 30,000 BTUH = 2.5 Tons										
36 = 36,000 BTUH = 3 Tons										
42 = 42,000 BTUH = 3.5 Tons										
48 = 48,000 BTUH = 4 Tons										
60 = 60,000 BTUH = 5 Tons										
000 = N/A										
K = 208/230-1-60										
00 = Standard										
Sales Model Digit										
Engineering Digit										