



FSA Product Specifications

APARTMENT FAN COILS

AVAILABLE WITH FACTORY INSTALLED 5, 7, & 11 kW ELECTRIC HEAT,
or NO HEAT

R-22 SYSTEMS

1½ THRU 3 TONS

FEATURES

- TXV metering device factory installed on all models
- Upflow only
- 22" wide galvanized steel cabinet fits between studs (24" stud spacing)
- All electrical and refrigerant lines enter through top of cabinet
- Service access through front of cabinet
- Primary and secondary drain fittings exit bottom, left, or right side of cabinet
- Air filter factory supplied with all models
- Copper tube / aluminum fin coil
- Sweat connections
- 5 amp automotive type fuse on control board
- Time delay relay (TDR)
- Wall-hung kit available as accessory
- Decorative grille available as accessory
- Field installed electric heater packages from 5 kW – 11 kW available separately
- 208/230-1-60 supply voltage



Rated in accordance with ARI Standard 210 and/or 240. Certification applies only when used with proper components as listed with ARI.

Model	Tons	Heat (kW)	Nom. CFM	Dimensions H x W x D (in)	Filter Size (in)	Ship. Weight
FSA2X1800A	1½	none	600	38 ³ / ₁₆ x 22 ¹ / ₈ x 15 ³ / ₁₆	16 x 20 x 1	85 lbs
FSA2X1805A	1½	5	600	38 ³ / ₁₆ x 22 ¹ / ₈ x 15 ³ / ₁₆	16 x 20 x 1	90 lbs
FSA2X1807A	1½	7	600	38 ³ / ₁₆ x 22 ¹ / ₈ x 15 ³ / ₁₆	16 x 20 x 1	90 lbs
FSA2X1811A	1½	11	600	38 ³ / ₁₆ x 22 ¹ / ₈ x 15 ³ / ₁₆	16 x 20 x 1	90 lbs
FSA2X2400A	2	none	800	38 ³ / ₁₆ x 22 ¹ / ₈ x 15 ³ / ₁₆	16 x 20 x 1	87 lbs
FSA2X2405A	2	5	800	38 ³ / ₁₆ x 22 ¹ / ₈ x 15 ³ / ₁₆	16 x 20 x 1	92 lbs
FSA2X2407A	2	7	800	38 ³ / ₁₆ x 22 ¹ / ₈ x 15 ³ / ₁₆	16 x 20 x 1	92 lbs
FSA2X2411A	2	11	800	38 ³ / ₁₆ x 22 ¹ / ₈ x 15 ³ / ₁₆	16 x 20 x 1	92 lbs
FSA2X3000A	2½	none	1000	38 ³ / ₁₆ x 22 ¹ / ₈ x 15 ³ / ₁₆	16 x 20 x 1	90 lbs
FSA2X3005A	2½	5	1000	38 ³ / ₁₆ x 22 ¹ / ₈ x 15 ³ / ₁₆	16 x 20 x 1	95 lbs
FSA2X3007A	2½	7	1000	38 ³ / ₁₆ x 22 ¹ / ₈ x 15 ³ / ₁₆	16 x 20 x 1	95 lbs
FSA2X3011A	2½	11	1000	38 ³ / ₁₆ x 22 ¹ / ₈ x 15 ³ / ₁₆	16 x 20 x 1	95 lbs
FSA2X3600A	3	none	1200	43 ³ / ₁₆ x 22 ¹ / ₈ x 18 ³ / ₈	20 x 20 x 1	105 lbs
FSA2X3605A	3	5	1200	43 ³ / ₁₆ x 22 ¹ / ₈ x 18 ³ / ₈	20 x 20 x 1	110 lbs
FSA2X3607A	3	7	1200	43 ³ / ₁₆ x 22 ¹ / ₈ x 18 ³ / ₈	20 x 20 x 1	110 lbs
FSA2X3611A	3	11	1200	43 ³ / ₁₆ x 22 ¹ / ₈ x 18 ³ / ₈	20 x 20 x 1	110 lbs

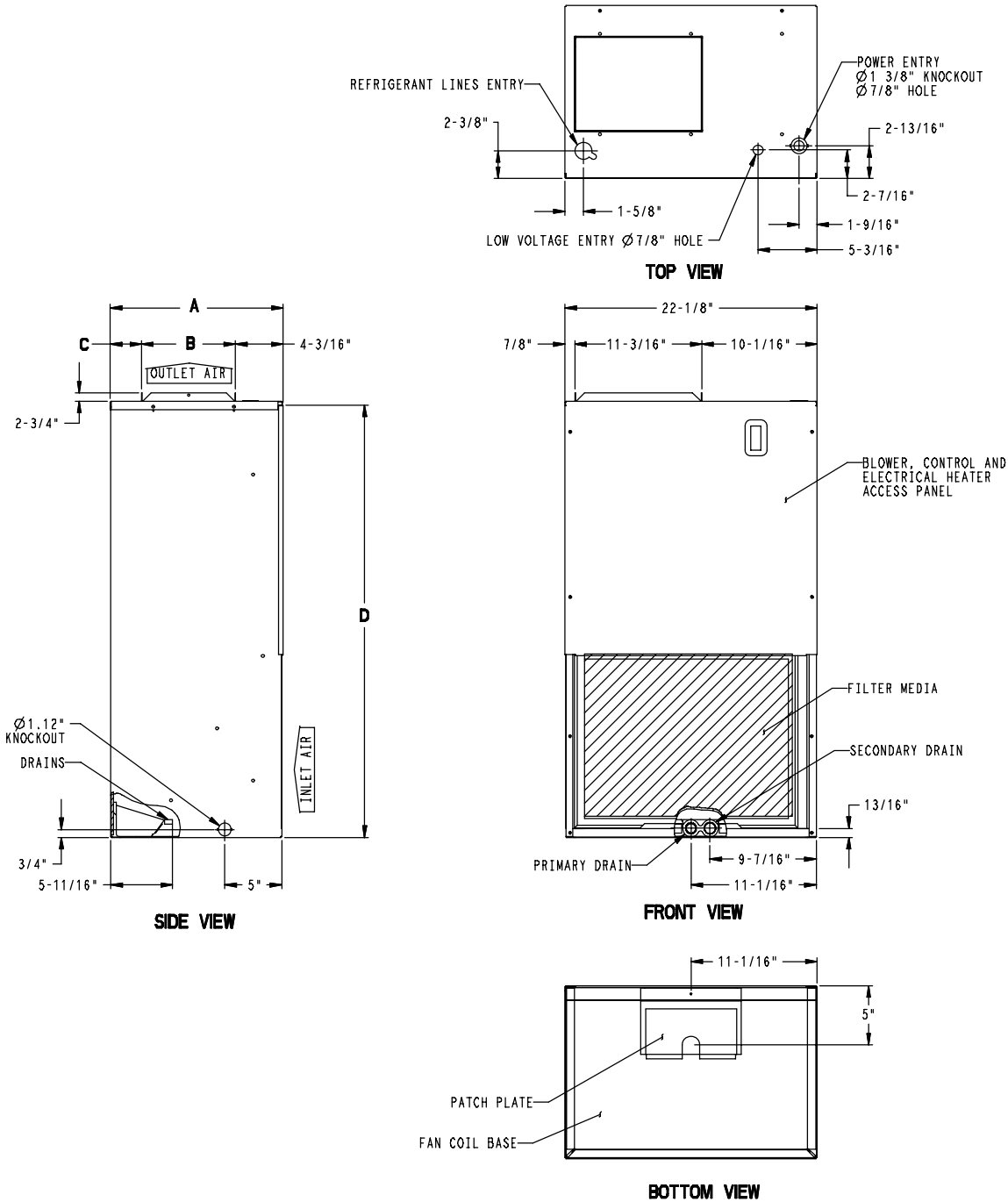

DIMENSIONAL DATA (inches)

Model Size	A	B	C	D
FSA2X18	15 ³ / ₁₆	8 ¹ / ₄	2 ³ / ₄	38 ¹ / ₁₆
FSA2X24	15 ³ / ₁₆	8 ¹ / ₄	2 ³ / ₄	38 ¹ / ₁₆
FSA2X30	15 ³ / ₁₆	8 ¹ / ₄	2 ³ / ₄	38 ¹ / ₁₆
FSA2X36	18 ³ / ₈	9 ¹ / ₄	5	43 ³ / ₁₆

PHYSICAL DATA				
Model Size	FSA2X18	FSA2X24	FSA2X30	FSA2X36
TXV factory installed, hard shut-off, bi-flow type for heat pump application				
TXV Size	3 ton			
Blower Data (direct drive, 10" dia x 6" wide blower wheel)				
CFM (nominal)	600	800	1000	1200
Motor type	2-speed, PSC (Permanent Split Capacitor)			
HP	1/5	1/5	1/3	1/3
Filter Data (cleanable filter factory supplied with unit)				
Filter Size	16 x 20 x 1			20 x 20 x 1
Coil Data (all coils Slope type, 3 rows, 14½ fins per inch)				
face area (ft ²)	2.23	2.72		3.46
Connections				
Refrigerant Liquid	3/8" sweat			
Refrigerant Suction	3/4" sweat			
Condensate Drain	3/4" female NPT, Primary and Secondary			

ELECTRICAL DATA					
	208 / 230V, single phase, 60 Hz				
Model	Motor Full Load Amps (FLA)	Factory Installed Heater Model	Heater Amps 208V / 230V	Minimum Circuit Ampacity (MCA) 208V / 230V	Maximum Fuse/Circuit Breaker Amps (MOCP) 208V / 230V
FSA2X1800	1.5	none	0	2.5	15
FSA2X1805	1.5	MAMWK005AH	18.1 / 20.0	24.5 / 26.9	25 / 30
FSA2X1807	1.5	MAMWK007AH	27.1 / 30.0	35.8 / 39.4	40 / 40
FSA2X1811	1.5	MAMWK011AH	39.8 / 44.0	51.6 / 56.9	60 / 60
FSA2X2400	1.5	none	0	2.5	15
FSA2X2405	1.5	MAMWK005AH	18.1 / 20.0	24.5 / 26.9	25 / 30
FSA2X2407	1.5	MAMWK007AH	27.1 / 30.0	35.8 / 39.4	40 / 40
FSA2X2411	1.5	MAMWK011AH	39.8 / 44.0	51.6 / 56.9	60 / 60
FSA2X3000	1.9	none	0	2.5	15
FSA2X3005	1.9	MAMWK005AH	18.1 / 20.0	25.0 / 27.4	30 / 30
FSA2X3007	1.9	MAMWK007AH	27.1 / 30.0	36.3 / 39.9	40 / 40
FSA2X3011	1.9	MAMWK011AH	39.8 / 44.0	52.1 / 57.4	60 / 60
FSA2X3600	2.0	none	0	2.5	15
FSA2X3605	2.0	MAMWK005AH	18.1 / 20.0	25.1 / 27.5	30 / 30
FSA2X3607	2.0	MAMWK007AH	27.1 / 30.0	36.4 / 40.0	40 / 40
FSA2X3611	2.0	MAMWK011AH	39.8 / 44.0	52.3 / 57.5	60 / 60

AIRFLOW PERFORMANCE – CFM at a given Speed and Static reading							
Model Size	Blower Speed	Measured Static Pressure, inlet to outlet (inches water column)					
		0.10	0.20	0.30	0.40	0.50	0.60
FSA2X18	High	995	955	910	862	811	–
	Low	738	711	678	641	600	–
FSA2X24	High	950	908	861	810	754	693
	Low	732	699	662	621	576	527
FSA2X30	High	1128	1082	1030	973	911	845
	Low	1053	1011	964	911	854	791
FSA2X36	High	1408	1355	1295	1227	1152	1068
	Low	1191	1157	1113	1061	1000	931

NOTES:

1. Airflow based on dry coil at 230V with factory approved filter and 2 element electric heater.
2. Not recommended for use above 0.60 inches water column external static pressure.
3. Shaded cells indicate airflow is greater than 450 CFM per ton.

STATIC PRESSURE CORRECTION FROM DRY TO WET COIL (inches of water column)									
AIRFLOW PERFORMANCE chart was developed using fan coils with DRY coils. When taking a static reading across a WET coil, adjust the static pressure numbers in the AIRFLOW PERFORMANCE chart by subtracting the values in this table.									
Model Size	CFM								
	500	600	700	800	900	1000	1100	1200	1300
FSA2X18	.034	.049	.063	–	–	–	–	–	–
FSA2X24	.021	.033	.045	.056	.068	–	–	–	–
FSA2X30	–	–	–	.056	.068	.079	.090	–	–
FSA2X36	–	–	–	–	–	.055	.064	.073	.081

STATIC PRESSURE CORRECTION FOR ELECTRIC HEATERS (inches of water column)									
AIRFLOW PERFORMANCE chart was developed using fan coils with 2–element electric heaters (7.5 kW or 11 kW). When using a 1–element electric heater (5 kW), or no electric heater, adjust the static pressure numbers in the AIRFLOW PERFORMANCE chart by adding the values in this table.									
Electric Heater	CFM								
	500	600	700	800	900	1000	1100	1200	1300
none	.012	.018	.028	.050	.075	.100	.130	–	–
5 kW	.002	.003	.003	.015	.020	.030	.050	–	–

ACCESSORIES	
Description	Part Number
Cooling Control Kit	AMWK001CK
Louvered Wall Panel with Frame for model sizes 18, 24, 30 (package of 6)	AMWK001WG
Louvered Wall Panel with Frame for model size 36 (package of 6)	AMWK002WG
Wall Mounting (Suspended) Brackets Kit	AMWK001MK

ELECTRIC HEATERS			
Part Number	Description	Heating Capacity (Btuh)	
		208V	230V
AMWK005AH	5 kW, single phase, 208 / 230V, 60 Hz	14,300	17,200
AMWK007AH	7 kW, single phase, 208 / 230V, 60 Hz	20,700	25,000
AMWK011AH	11 kW, single phase, 208 / 230V, 60 Hz	29,700	36,000

FAN COIL MODEL NUMBER IDENTIFICATION GUIDE								
	F	S	A	2	X	18**	A	1
F = Fan Coil		MOTOR TYPE						
S = Standard PSC		INSTALLATION TYPE						
A = Apartment				REFRIGERANT				
2 = R-22						METERING DEVICE		
X = TXV								
18** = 18,000 BTUH = 1½ tons								
24** = 24,000 BTUH = 2 tons								
30** = 30,000 BTUH = 2½ tons								
36** = 36,000 BTUH = 3 tons						NOMINAL CAPACITY		
Sales Code								
Engineering Revision								

ACCESSORY MODEL NUMBER IDENTIFICATION GUIDE							
	A	M	WK	001	CK	A	1
A = Accessory		PRODUCT TYPE					
C = Cooling							
H = Heating							
M = Multi-use (Cooling and/or Heating)							
X = Special							
Series							
Product Identifier							
Product Identifier (see below)							
Sales Code							
Engineering Revision							
Product Identifier Codes							
AH = Auxiliary Heater		MK = Wall Mounting Brackets Kit					
CK = Cooling Control Kit		WG = Louvered Wall Panel with Frame					