

TECHNICAL SUPPORT MANUAL

Split System Air Conditioner

N4A4

Safety Labeling and Signal Words

DANGER, WARNING, CAUTION, and NOTE

The signal words **DANGER**, **WARNING**, **CAUTION**, and **NOTE** are used to identify levels of hazard seriousness. The signal word **DANGER** is only used on product labels to signify an immediate hazard. The signal words **WARNING**, **CAUTION**, and **NOTE** will be used on product labels and throughout this manual and other manuals that may apply to the product.

DANGER – Immediate hazards which **will** result in severe personal injury or death.

WARNING – Hazards or unsafe practices which **could** result in severe personal injury or death.

CAUTION – Hazards or unsafe practices which **may** result in minor personal injury or product or property damage.

NOTE – Used to highlight suggestions which **will** result in enhanced installation, reliability, or operation.

Signal Words in Manuals

The signal word **WARNING** is used throughout this manual in the following manner:



The signal word **CAUTION** is used throughout this manual in the following manner:



Signal Words on Product Labeling

Signal words are used in combination with colors and/or pictures on product labels.

TABLE OF CONTENTS

Wiring Diagrams	2
Charging Chart	3
Tech Labels (Expanded Data)	4 – 11
Condenser Only Data	12 – 15
Cooling Multiplying Factors	16 – 22
Model Number Identification	23

MODELS

- N4A418*KA300
- N4A424*KB300
- N4A430*KB300
- N4A436*KA300
- N4A442*KB300
- N4A448*KB300
- N4A449*KB300
- N4A460*KB400

* = A for standard inlet grille,
G for inlet grille with 3/8" (10mm) tight-wire spacing



DEATH, PERSONAL INJURY, AND/OR PROPERTY DAMAGE HAZARD

Failure to carefully read and follow this warning could result in equipment malfunction, property damage, personal injury and/or death.

Installation or repairs made by unqualified persons could result in equipment malfunction, property damage, personal injury and/or death.

The information contained in this manual is intended for use by a qualified service technician familiar with safety procedures and equipped with the proper tools and test instruments.

Installation must conform with local building codes and with the National Electrical Code NFPA70 current edition or Canadian Electrical Code Part 1 CSA C.22.1.

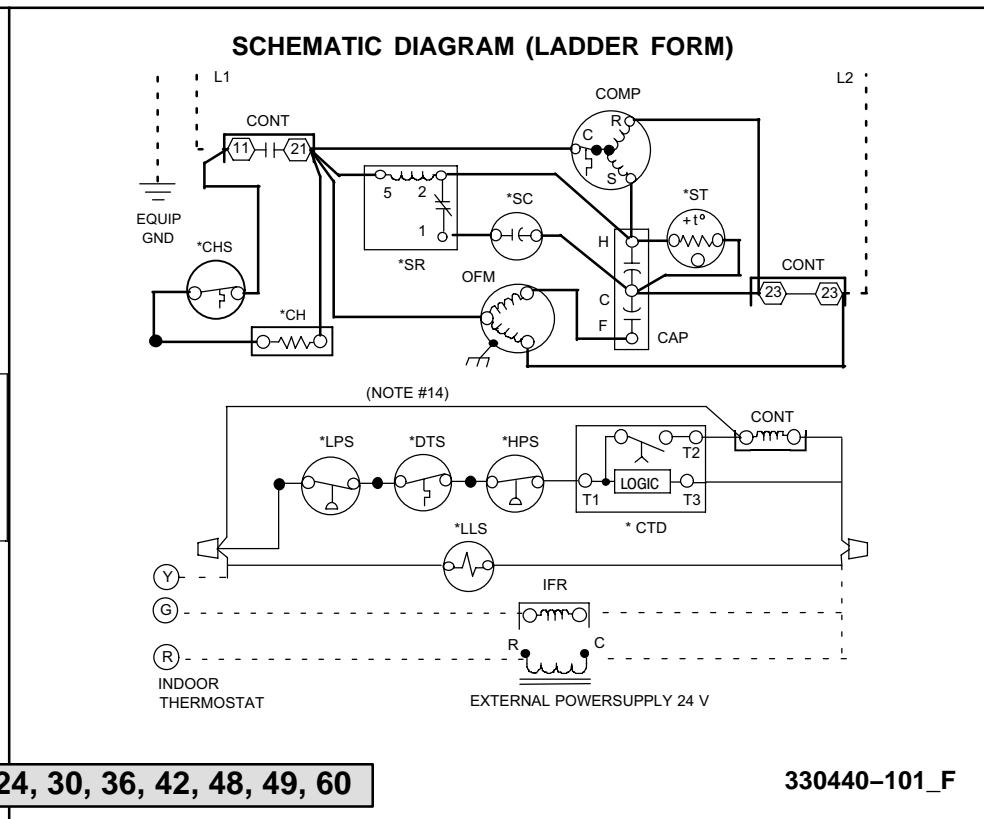
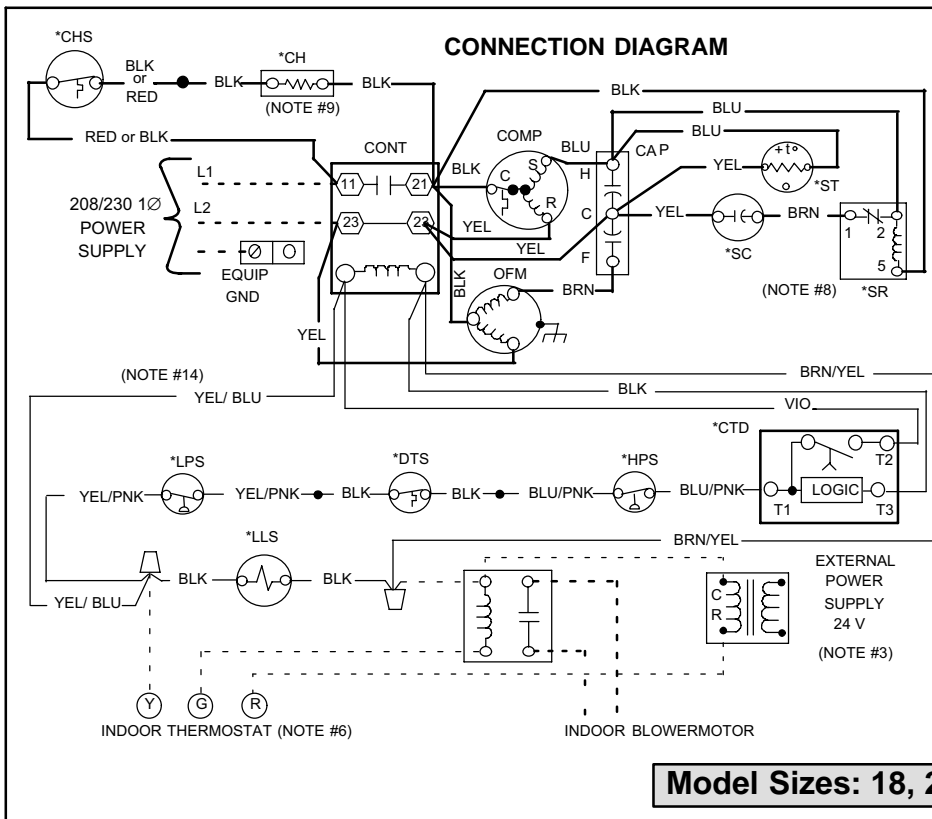

Model Sizes: 18, 24, 30, 36, 42, 48, 49, 60

330440-101_F

1. Symbols are electrical representation only.
2. Compressor and fan motor furnished with inherent thermal protection.
3. To be wired in accordance with National Electric N.E.C. and local codes.
4. N.E.C. class 2, 24 V circuit, min. 40 VA required, 60 VA on units installed with LLS.
5. Use copper conductors only. Use conductors suitable for at least 75°C (167°F).
6. Connection for typical cooling only thermostat. For other arrangements see installation instructions.
7. If indoor section has a transformer with a grounded secondary, connect the grounded side to the BRN/YEL lead.
8. When start capacitor and relay are installed, start thermistor (PTC) is not used.
9. CH not used on all units.
10. If any of the original wire, as supplied, must be replaced, use the same or equivalent wire.
11. Check all electrical connections inside control box for tightness.
12. Do not attempt to operate unit until service valves have been opened.
13. Do not rapid cycle compressor. Compressor must be off 3 minutes to allow pressures to equalize between high and low side before starting.
14. Wire not present if HPS, LPS or CTD are used.

LEGEND

—	FACTORY POWER WIRING
—	FACTORY CONTROL WIRING
- - -	FIELD CONTROL WIRING
- - -	FIELD POWER WIRING
○	COMPONENT CONNECTION
⊕	FIELD SPLICE
●	JUNCTION
⊏	PLUG RECEPTACLE
CONT	CONTACTOR
CAP	CAPACITOR (DUAL RUN)
*CH	CRANKCASE HEATER
*CHS	CRANKCASE HEATER SWITCH
COMP	COMPRESSOR
*CTD	COMPRESSOR TIME DELAY
*DTS	DISCHARGE TEMP SWITCH
*HPS	HIGH PRESSURE SWITCH
IFR	INDOOR FAN RELAY
*LLS	LIQ LINE SOLENOID VALVE
*LPS	LOW PRESSURE SWITCH
OFM	OUTDOOR FAN MOTOR
*SC	START CAPICATOR
*SR	START RELAY
*ST	START THERMISTOR

* MAY BE FACTORY INSTALLED

R-410A CHARGING CHART												
Measured Liquid Pressure (psig)	Rating Plate (required) Subcooling Temperature ° F (° C)											
	° F 6	(° C) 3	° F 8	(° C) 4	° F 10	(° C) 6	° F 12	(° C) 7	F 14	(° C) 8	F 16	(° C) 9
	R-410A Required Liquid Line Temperature ° F (° C)											
251	78	26	76	24	74	23	72	22	70	21	68	20
259	80	27	78	26	76	24	74	23	72	22	70	21
266	82	28	80	27	78	26	76	24	74	23	72	22
274	84	29	82	28	80	27	78	26	76	24	74	23
283	86	30	84	29	82	28	80	27	78	26	76	24
291	88	31	86	30	84	29	82	28	80	27	78	26
299	90	32	88	31	86	30	84	29	82	28	80	27
308	92	33	90	32	88	31	86	30	84	29	82	28
317	94	34	92	33	90	32	88	31	86	30	84	29
326	96	36	94	34	92	33	90	32	88	31	86	30
335	98	37	96	36	94	34	92	33	90	32	88	31
345	100	38	98	37	96	36	94	34	92	33	90	32
364	104	40	102	39	100	38	98	37	96	36	94	34
374	106	41	104	40	102	39	100	38	98	37	96	36
384	108	42	106	41	104	40	102	39	100	38	98	37
395	110	43	108	42	106	41	104	40	102	39	100	38
406	112	44	110	43	108	42	106	41	104	40	102	39
416	114	46	112	44	110	43	108	42	106	41	104	40
427	116	47	114	46	112	44	110	43	108	42	106	41
439	118	48	116	47	114	46	112	44	110	43	108	42
450	120	49	118	48	116	47	114	46	112	44	110	43
462	122	50	120	49	118	48	116	47	114	46	112	44
474	124	51	122	50	120	49	118	48	116	47	114	46

COOLING		18 Size Outdoor With ED*4X24B** Indoor Cooling																								
		Outdoor Ambient Temperature – Degrees F, Dry Bulb																								
		75					85					95					105					115				
		Entering Indoor Temperature – Degrees F, Wet Bulb																								
CFM		72	67	62	57	72	67	62	57	72	67	62	57	72	67	62	57	72	67	62	57					
525	MBh†	21.57	19.60	17.82	17.16	20.52	18.65	16.96	16.49	19.45	17.67	16.08	15.79	18.33	16.65	15.18	15.06	17.18	15.60	14.29	14.29					
	S/T‡	0.52	0.70	0.90	1.00	0.53	0.71	0.92	1.00	0.53	0.73	0.95	1.00	0.54	0.74	0.97	1.00	0.56	0.77	1.00	1.00					
	AMPS*	5.08	5.14	5.19	5.21	5.74	5.80	5.85	5.86	6.47	6.53	6.58	6.58	7.28	7.34	7.39	7.39	8.18	8.24	8.29	8.29					
	HI PR	262	259	256	255	303	300	297	297	349	345	342	342	399	395	392	391	453	449	446	446					
	LO PR	157	144	132	128	160	146	134	131	162	149	137	135	165	151	139	138	167	154	143	143					
600	MBh†	22.01	20.03	18.27	17.96	20.92	19.03	17.38	17.23	19.79	18.00	16.50	16.48	18.62	16.94	15.70	15.70	17.42	15.84	14.86	14.87					
	S/T‡	0.53	0.73	0.95	1.00	0.54	0.74	0.97	1.00	0.55	0.76	0.99	1.00	0.56	0.78	1.00	1.00	0.58	0.81	1.00	1.00					
	AMPS*	5.19	5.25	5.30	5.31	5.85	5.90	5.95	5.95	6.58	6.63	6.68	6.68	7.39	7.45	7.49	7.49	8.29	8.35	8.39	8.39					
	HI PR	262	260	257	257	304	301	298	298	350	346	343	343	400	396	393	393	454	450	447	447					
	LO PR	161	148	136	134	164	150	138	137	166	152	141	141	168	154	144	144	171	157	148	148					
675	MBh†	22.34	20.35	18.68	18.63	21.20	19.31	17.86	17.86	20.03	18.25	17.06	17.06	18.83	17.15	16.22	16.22	17.58	16.02	15.33	15.33					
	S/T‡	0.55	0.76	0.99	1.00	0.56	0.78	1.00	1.00	0.57	0.80	1.00	1.00	0.59	0.82	1.00	1.00	0.60	0.85	1.00	1.00					
	AMPS*	5.30	5.36	5.41	5.41	5.96	6.01	6.06	6.06	6.69	6.75	6.78	6.78	7.50	7.56	7.59	7.59	8.40	8.46	8.49	8.49					
	HI PR	263	260	258	258	305	302	299	299	351	347	345	345	400	397	394	394	454	450	449	449					
	LO PR	164	151	140	139	166	153	143	143	169	155	146	146	171	157	150	150	173	159	154	154					

- † Total capacities are net (I.D. blower heat subtracted) system capacities based on 25' line set.
If additional tubing length and/or indoor unit is located above outdoor unit, a slight variation in capacity may occur.
- †† At TVA rating indoor condition (75 °F db, 63 °F wb), all other indoor air temperatures are at 80 °F db
If additional tubing length and/or indoor unit is located above outdoor unit, a slight variation in capacity may occur.
- ^ System amps are total of indoor and outdoor amps.
- ‡ Chart data is for 80° F indoor dry bulb. For indoor db temperatures other than 80° F, measure Indoor db and Indoor CFM, and plug these into the formula below. Measure outdoor db and indoor wet bulb, apply these to the chart above, find MBh and S/T, and plug these into the formula below.
(Note: if indoor db is the only thing changing, total capacity, MBh, stays the same.)

Sensible Capacity at Indoor db LOWER than 80 °F = (MBh x S/T) - $\left(\frac{(80 - \text{Indoor db}) \times 835 \times \text{Indoor CFM}}{1000} \right)$

Sensible Capacity at Indoor db HIGHER than 80 °F = (MBh x S/T) + $\left(\frac{(\text{Indoor db} - 80) \times 835 \times \text{Indoor CFM}}{1000} \right)$

COOLING		24 Size Outdoor With ED*4X24B** Indoor Cooling																			
		Outdoor Ambient Temperature – Degrees F, Dry Bulb																			
		75				85				95				105				115			
		Entering Indoor Temperature – Degrees F, Wet Bulb																			
CFM		72	67	62	57	72	67	62	57	72	67	62	57	72	67	62	57	72	67	62	57
700	MBh†	27.67	25.12	22.88	22.21	26.44	23.98	21.86	21.39	25.16	22.80	20.79	20.53	23.80	21.54	19.69	19.60	22.34	20.19	18.60	18.60
	S/T‡	0.50	0.67	0.86	1.00	0.50	0.68	0.88	1.00	0.51	0.69	0.91	1.00	0.52	0.71	0.93	1.00	0.53	0.73	1.00	1.00
	AMPS*	6.85	6.86	6.87	6.87	7.67	7.68	7.69	7.70	8.59	8.60	8.62	8.62	9.61	9.63	9.64	9.64	10.75	10.77	10.78	10.78
	HI PR	256	254	252	251	297	295	293	292	342	340	337	337	391	389	387	386	445	443	441	441
	LO PR	155	143	131	127	158	145	133	131	160	147	136	134	162	149	138	138	165	152	142	142
800	MBh†	28.21	25.62	23.44	23.17	26.93	24.43	22.40	22.30	25.58	23.20	21.36	21.37	24.17	21.90	20.39	20.39	22.65	20.50	19.32	19.32
	S/T‡	0.51	0.70	0.91	1.00	0.52	0.71	0.93	1.00	0.53	0.73	1.00	1.00	0.54	0.75	1.00	1.00	0.55	0.78	1.00	1.00
	AMPS*	7.02	7.02	7.03	7.03	7.84	7.85	7.86	7.86	8.76	8.77	8.78	8.78	9.78	9.79	9.81	9.81	10.92	10.94	10.95	10.95
	HI PR	256	254	253	252	298	295	293	293	343	340	338	338	392	389	388	388	446	443	442	442
	LO PR	159	146	135	133	161	148	137	136	163	150	140	140	165	152	143	143	168	155	147	147
900	MBh†	28.61	25.99	23.98	23.98	27.28	24.78	23.05	23.05	25.89	23.50	22.07	22.07	24.43	22.16	21.03	21.03	22.87	20.73	19.90	19.90
	S/T‡	0.53	0.73	1.00	1.00	0.54	0.74	1.00	1.00	0.55	0.76	1.00	1.00	0.56	0.79	1.00	1.00	0.57	0.82	1.00	1.00
	AMPS*	7.18	7.19	7.20	7.20	8.01	8.02	8.03	8.03	8.93	8.94	8.95	8.95	9.95	9.96	9.97	9.97	11.09	11.10	11.11	11.11
	HI PR	257	255	253	253	298	296	294	294	343	341	339	339	393	390	389	389	446	444	443	443
	LO PR	162	149	138	138	164	151	141	141	166	153	145	145	168	155	148	148	170	157	152	152

† Total capacities are net (I.D. blower heat subtracted) system capacities based on 25' line set.
If additional tubing length and/or indoor unit is located above outdoor unit, a slight variation in capacity may occur.

†† At TVA rating indoor condition (75 °F db, 63 °F wb), all other indoor air temperatures are at 80 °F db
If additional tubing length and/or indoor unit is located above outdoor unit, a slight variation in capacity may occur.

^ System amps are total of indoor and outdoor amps.

‡ Chart data is for 80° F indoor dry bulb. For indoor db temperatures other than 80° F, measure Indoor db and Indoor CFM, and plug these into the formula below. Measure outdoor db and indoor wet bulb, apply these to the chart above, find MBh and S/T, and plug these into the formula below.
(Note: if indoor db is the only thing changing, total capacity, MBh, stays the same.)

$$\text{Sensible Capacity at Indoor db LOWER than } 80^\circ \text{ F} = (\text{MBh} \times \text{S/T}) - \left(\frac{(\text{80} - \text{Indoor db}) \times 835 \times \text{Indoor CFM}}{1000} \right)$$

$$\text{Sensible Capacity at Indoor db HIGHER than } 80^\circ \text{ F} = (\text{MBh} \times \text{S/T}) + \left(\frac{(\text{Indoor db} - 80) \times 835 \times \text{Indoor CFM}}{1000} \right)$$

COOLING		30 Size Outdoor With ED*4X30B** Indoor Cooling																								
		Outdoor Ambient Temperature – Degrees F, Dry Bulb																								
		75					85					95					105					115				
		Entering Indoor Temperature – Degrees F, Wet Bulb																								
CFM		72	67	62	57	72	67	62	57	72	67	62	57	72	67	62	57	72	67	62	57					
875	MBh†	34.32	31.45	28.82	28.00	32.83	30.06	27.56	26.98	31.24	28.59	26.24	25.89	29.59	27.04	24.86	24.74	27.80	25.38	23.47	23.48					
	S/T‡	0.50	0.67	0.87	1.00	0.51	0.69	0.89	1.00	0.52	0.70	0.91	1.00	0.53	0.72	0.94	1.00	0.54	0.74	1.00	1.00					
	AMPS*	8.68	8.66	8.65	8.64	9.67	9.65	9.64	9.63	10.77	10.75	10.74	10.73	11.99	11.97	11.95	11.94	13.32	13.29	13.27	13.27					
	HI PR	269	266	263	262	312	308	304	304	358	354	350	350	408	404	400	400	462	458	454	454					
	LO PR	155	142	130	126	157	144	132	129	159	146	134	133	162	148	137	136	164	151	140	140					
1000	MBh†	34.88	31.98	29.44	29.10	33.32	30.53	28.16	28.01	31.66	29.00	26.81	26.85	29.96	27.40	25.62	25.62	28.11	25.69	24.28	24.28					
	S/T‡	0.52	0.70	0.91	1.00	0.52	0.72	0.93	1.00	0.53	0.73	1.00	1.00	0.54	0.75	1.00	1.00	0.56	0.78	1.00	1.00					
	AMPS*	8.89	8.87	8.86	8.86	9.89	9.87	9.85	9.85	10.98	10.96	10.95	10.95	12.20	12.18	12.16	12.16	13.53	13.51	13.49	13.49					
	HI PR	270	267	264	263	313	309	305	305	359	355	351	351	409	405	401	401	463	459	456	456					
	LO PR	158	145	134	132	160	147	136	135	163	149	138	138	165	151	142	142	167	154	146	146					
1125	MBh†	35.27	32.36	30.02	29.99	33.67	30.87	28.84	28.84	31.96	29.29	27.62	27.62	30.22	27.66	26.32	26.32	28.32	25.91	24.92	24.92					
	S/T‡	0.53	0.73	0.95	1.00	0.54	0.75	1.00	1.00	0.55	0.77	1.00	1.00	0.56	0.79	1.00	1.00	0.58	0.82	1.00	1.00					
	AMPS*	9.11	9.08	9.07	9.07	10.10	10.08	10.06	10.06	11.20	11.18	11.16	11.16	12.41	12.39	12.38	12.38	13.74	13.72	13.71	13.71					
	HI PR	271	267	264	264	313	309	307	307	360	355	353	353	410	405	403	403	464	459	457	458					
	LO PR	161	148	137	137	163	150	140	140	165	152	143	143	167	154	147	147	169	156	151	151					

† Total capacities are net (I.D. blower heat subtracted) system capacities based on 25' line set.

If additional tubing length and/or indoor unit is located above outdoor unit, a slight variation in capacity may occur.

†† At TVA rating indoor condition (75 °F db, 63 °F wb), all other indoor air temperatures are at 80 °F db

If additional tubing length and/or indoor unit is located above outdoor unit, a slight variation in capacity may occur.

^ System amps are total of indoor and outdoor amps.

‡ Chart data is for 80° F indoor dry bulb. For indoor db temperatures other than 80° F, measure Indoor db and Indoor CFM, and plug these into the formula below. Measure outdoor db and indoor wet bulb, apply these to the chart above, find MBh and S/T, and plug these into the formula below. (Note: if indoor db is the only thing changing, total capacity, MBh, stays the same.)

$$\text{Sensible Capacity at Indoor db LOWER than } 80^{\circ}\text{F} = (\text{MBh} \times \text{S/T}) - \left(\frac{(\text{80} - \text{Indoor db}) \times 835 \times \text{Indoor CFM}}{1000} \right)$$

$$\text{Sensible Capacity at Indoor db HIGHER than } 80^{\circ}\text{F} = (\text{MBh} \times \text{S/T}) + \left(\frac{(\text{Indoor db} - 80) \times 835 \times \text{Indoor CFM}}{1000} \right)$$

COOLING		36 Size Outdoor With ED*4X42J** Indoor Cooling																			
		Outdoor Ambient Temperature – Degrees F, Dry Bulb																			
		75				85				95				105				115			
		Entering Indoor Temperature – Degrees F, Wet Bulb																			
CFM		72	67	62	57	72	67	62	57	72	67	62	57	72	67	62	57	72	67	62	57
1050	MBh†	42.83	38.83	35.34	34.26	40.92	37.06	33.74	32.98	38.92	35.20	32.07	31.63	36.78	33.22	30.32	30.17	34.47	31.08	28.58	28.58
	S/T‡	0.52	0.70	0.91	1.00	0.53	0.72	0.93	1.00	0.54	0.73	0.95	1.00	0.55	0.75	0.98	1.00	0.56	0.77	1.00	1.00
	AMPS*	10.21	10.21	10.20	10.20	11.44	11.43	11.42	11.42	12.79	12.78	12.77	12.77	14.32	14.30	14.29	14.29	16.01	16.00	15.98	15.98
	HI PR	249	249	249	249	291	292	292	292	338	339	339	339	389	390	391	391	444	446	448	448
	LO PR	150	137	126	123	152	139	128	126	154	142	131	129	157	144	134	133	160	147	137	137
1200	MBh†	43.66	39.58	36.18	35.72	41.67	37.74	34.56	34.36	39.58	35.80	32.87	32.91	37.36	33.75	31.35	31.36	34.96	31.55	29.67	29.67
	S/T‡	0.54	0.73	0.95	1.00	0.55	0.75	0.97	1.00	0.55	0.77	1.00	1.00	0.57	0.79	1.00	1.00	0.58	0.82	1.00	1.00
	AMPS*	10.44	10.44	10.43	10.43	11.66	11.65	11.64	11.65	13.02	13.01	13.00	13.00	14.54	14.53	14.52	14.52	16.23	16.23	16.21	16.22
	HI PR	248	249	249	249	291	292	292	292	338	339	339	339	388	390	391	391	443	446	447	447
	LO PR	153	140	130	128	155	142	132	131	157	145	134	135	160	147	138	138	162	150	142	142
1350	MBh†	44.27	40.14	36.97	36.94	42.22	38.24	35.49	35.50	40.06	36.25	33.97	33.97	37.77	34.15	32.33	32.34	35.31	31.89	30.56	30.56
	S/T‡	0.55	0.76	0.99	1.00	0.56	0.78	1.00	1.00	0.57	0.80	1.00	1.00	0.58	0.82	1.00	1.00	0.60	0.86	1.00	1.00
	AMPS*	10.66	10.66	10.65	10.65	11.88	11.88	11.87	11.87	13.24	13.23	13.23	13.23	14.77	14.76	14.75	14.75	16.46	16.45	16.44	16.44
	HI PR	248	249	249	249	291	292	292	292	338	338	339	339	388	390	390	390	442	445	446	446
	LO PR	155	143	133	133	158	145	136	136	160	147	139	139	162	149	143	143	164	152	147	147

† Total capacities are net (I.D. blower heat subtracted) system capacities based on 25' line set.
If additional tubing length and/or indoor unit is located above outdoor unit, a slight variation in capacity may occur.

†† At TVA rating indoor condition (75 °F db, 63 °F wb), all other indoor air temperatures are at 80 °F db
If additional tubing length and/or indoor unit is located above outdoor unit, a slight variation in capacity may occur.

^ System amps are total of indoor and outdoor amps.

‡ Chart data is for 80° F indoor dry bulb. For indoor db temperatures other than 80° F, measure Indoor db and Indoor CFM, and plug these into the formula below. Measure outdoor db and indoor wet bulb, apply these to the chart above, find MBh and S/T, and plug these into the formula below.
(Note: if indoor db is the only thing changing, total capacity, MBh, stays the same.)

$$\text{Sensible Capacity at Indoor db LOWER than } 80^\circ \text{ F} = (\text{MBh} \times \text{S/T}) - \left(\frac{(\text{80} - \text{Indoor db}) \times 835 \times \text{Indoor CFM}}{1000} \right)$$

$$\text{Sensible Capacity at Indoor db HIGHER than } 80^\circ \text{ F} = (\text{MBh} \times \text{S/T}) + \left(\frac{(\text{Indoor db} - 80) \times 835 \times \text{Indoor CFM}}{1000} \right)$$

COOLING		42 Size Outdoor With ED*4X48* Indoor Cooling																								
		Outdoor Ambient Temperature – Degrees F, Dry Bulb																								
		75					85					95					105					115				
		Entering Indoor Temperature – Degrees F, Wet Bulb																								
CFM		72	67	62	57	72	67	62	57	72	67	62	57	72	67	62	57	72	67	62	57					
1225	MBh†	47.98	43.86	40.13	39.05	45.92	41.96	38.41	37.67	43.69	39.91	36.57	36.17	41.29	37.70	34.63	34.53	38.70	35.31	32.73	32.74					
	S/T‡	0.52	0.70	0.91	1.00	0.53	0.72	0.93	1.00	0.54	0.73	0.95	1.00	0.55	0.75	0.98	1.00	0.56	0.78	1.00	1.00					
	AMPS*	11.87	11.81	11.75	11.73	13.09	13.00	12.93	12.91	14.47	14.37	14.29	14.28	16.04	15.92	15.83	15.83	17.79	17.66	17.58	17.58					
	HI PR	272	269	265	264	315	311	307	307	362	357	353	353	412	407	403	403	467	462	458	458					
	LO PR	155	142	130	126	157	144	132	129	159	146	134	133	162	148	137	136	164	151	141	141					
1400	MBh†	48.78	44.62	41.02	40.64	46.63	42.63	39.28	39.15	44.31	40.50	37.54	37.54	41.82	38.21	35.79	35.79	39.14	35.75	33.88	33.88					
	S/T‡	0.54	0.74	0.96	1.00	0.55	0.75	0.98	1.00	0.56	0.77	1.00	1.00	0.57	0.79	1.00	1.00	0.58	0.82	1.00	1.00					
	AMPS*	12.18	12.10	12.05	12.04	13.39	13.30	13.23	13.23	14.78	14.67	14.60	14.60	16.35	16.23	16.16	16.16	18.09	17.97	17.91	17.91					
	HI PR	273	270	266	266	316	312	308	308	363	358	355	355	413	408	405	405	468	463	460	460					
	LO PR	159	145	134	132	161	147	136	135	163	149	139	139	165	151	142	142	167	154	146	146					
1575	MBh†	49.37	45.17	41.89	41.91	47.14	43.12	40.34	40.34	44.75	40.93	38.64	38.64	42.19	38.58	36.79	36.79	39.43	36.05	34.77	34.78					
	S/T‡	0.56	0.77	1.00	1.00	0.57	0.79	1.00	1.00	0.58	0.81	1.00	1.00	0.59	0.83	1.00	1.00	0.61	0.86	1.00	1.00					
	AMPS*	12.47	12.40	12.35	12.35	13.69	13.60	13.54	13.54	15.08	14.98	14.92	14.92	16.65	16.53	16.48	16.47	18.40	18.27	18.23	18.23					
	HI PR	274	270	267	267	317	313	310	310	364	359	356	356	414	409	407	407	469	464	462	462					
	LO PR	161	148	137	137	163	150	140	140	165	152	144	144	167	154	147	147	170	156	151	151					

- † Total capacities are net (I.D. blower heat subtracted) system capacities based on 25' line set.
If additional tubing length and/or indoor unit is located above outdoor unit, a slight variation in capacity may occur.
- †† At TVA rating indoor condition (75 °F db, 63 °F wb), all other indoor air temperatures are at 80 °F db
If additional tubing length and/or indoor unit is located above outdoor unit, a slight variation in capacity may occur.
- ^ System amps are total of indoor and outdoor amps.
- ‡ Chart data is for 80° F indoor dry bulb. For indoor db temperatures other than 80° F, measure Indoor db and Indoor CFM, and plug these into the formula below. Measure outdoor db and indoor wet bulb, apply these to the chart above, find MBh and S/T, and plug these into the formula below.
(Note: if indoor db is the only thing changing, total capacity, MBh, stays the same.)

Sensible Capacity at Indoor db LOWER than 80 °F = (MBh x S/T) - $\left(\frac{(80 - \text{Indoor db}) \times 835 \times \text{Indoor CFM}}{1000} \right)$

Sensible Capacity at Indoor db HIGHER than 80 °F = (MBh x S/T) + $\left(\frac{(\text{Indoor db} - 80) \times 835 \times \text{Indoor CFM}}{1000} \right)$

COOLING		48 Size Outdoor With ED*4X60L** Indoor Cooling																			
		Outdoor Ambient Temperature – Degrees F, Dry Bulb																			
		75				85				95				105				115			
		Entering Indoor Temperature – Degrees F, Wet Bulb																			
CFM		72	67	62	57	72	67	62	57	72	67	62	57	72	67	62	57	72	67	62	57
1400	MBh†	57.54	52.60	48.14	46.53	54.90	50.19	45.96	44.80	52.22	47.73	43.75	43.02	49.43	45.16	41.45	41.12	46.45	42.41	39.05	39.07
	S/T‡	0.51	0.68	0.87	1.00	0.51	0.69	0.89	1.00	0.52	0.70	0.92	1.00	0.53	0.72	0.94	1.00	0.54	0.74	1.00	1.00
	AMPS*	13.95	14.07	14.16	14.19	15.93	15.95	15.93	15.92	17.90	17.82	17.73	17.71	19.94	19.80	19.67	19.66	22.14	21.98	21.84	21.84
	HI PR	284	279	275	274	328	323	318	317	375	370	365	364	427	422	417	416	484	478	473	473
	LO PR	154	141	129	124	156	143	131	127	158	145	133	131	161	147	135	134	163	150	138	138
1600	MBh†	58.61	53.60	49.23	48.50	55.84	51.07	46.99	46.64	53.03	48.50	44.76	44.71	50.13	45.83	42.68	42.68	47.05	42.99	40.49	40.49
	S/T‡	0.52	0.71	0.92	1.00	0.53	0.72	0.94	1.00	0.54	0.74	0.99	1.00	0.55	0.76	1.00	1.00	0.56	0.78	1.00	1.00
	AMPS*	14.21	14.35	14.45	14.46	16.23	16.25	16.24	16.24	18.22	18.15	18.07	18.07	20.27	20.14	20.03	20.03	22.48	22.32	22.22	22.22
	HI PR	285	281	277	276	329	324	320	319	377	371	367	367	429	423	419	419	485	479	476	476
	LO PR	157	144	132	130	160	146	135	134	162	148	137	137	164	150	140	140	166	153	144	144
1800	MBh†	59.39	54.34	50.22	50.12	56.53	51.71	48.14	48.14	53.62	49.07	46.10	46.10	50.63	46.32	43.95	43.95	47.46	43.41	41.64	41.64
	S/T‡	0.54	0.74	0.99	1.00	0.55	0.75	1.00	1.00	0.56	0.77	1.00	1.00	0.57	0.80	1.00	1.00	0.58	0.83	1.00	1.00
	AMPS*	14.48	14.63	14.73	14.73	16.53	16.55	16.56	16.55	18.53	18.47	18.41	18.41	20.60	20.47	20.39	20.39	22.81	22.65	22.58	22.58
	HI PR	286	281	278	278	330	325	321	321	378	372	369	369	430	424	421	421	486	480	478	478
	LO PR	160	147	136	136	162	149	139	139	164	151	142	142	167	153	146	146	169	155	149	149

† Total capacities are net (I.D. blower heat subtracted) system capacities based on 25' line set.
If additional tubing length and/or indoor unit is located above outdoor unit, a slight variation in capacity may occur.

†† At TVA rating indoor condition (75 °F db, 63 °F wb), all other indoor air temperatures are at 80 °F db
If additional tubing length and/or indoor unit is located above outdoor unit, a slight variation in capacity may occur.

^ System amps are total of indoor and outdoor amps.

‡ Chart data is for 80° F indoor dry bulb. For indoor db temperatures other than 80° F, measure Indoor db and Indoor CFM, and plug these into the formula below. Measure outdoor db and indoor wet bulb, apply these to the chart above, find MBh and S/T, and plug these into the formula below.
(Note: if indoor db is the only thing changing, total capacity, MBh, stays the same.)

$$\text{Sensible Capacity at Indoor db LOWER than } 80^{\circ}\text{F} = (\text{MBh} \times \text{S/T}) - \left(\frac{(\text{80} - \text{Indoor db}) \times 835 \times \text{Indoor CFM}}{1000} \right)$$

$$\text{Sensible Capacity at Indoor db HIGHER than } 80^{\circ}\text{F} = (\text{MBh} \times \text{S/T}) + \left(\frac{(\text{Indoor db} - 80) \times 835 \times \text{Indoor CFM}}{1000} \right)$$

COOLING		49 Size Outdoor With ED*4X60L** Indoor Cooling																			
		Outdoor Ambient Temperature - Degrees F, Dry Bulb																			
		75				85				95				105				115			
		Entering Indoor Temperature - Degrees F, Wet Bulb																			
CFM		72	67	62	57	72	67	62	57	72	67	62	57	72	67	62	57	72	67	62	57
1400	MBh†	55.71	50.48	45.93	45.05	52.91	47.96	43.75	43.28	50.01	45.37	41.55	41.43	47.00	42.67	39.51	39.45	43.85	39.85	37.39	37.34
	S/T‡	0.50	0.68	0.88	1.00	0.51	0.70	0.91	1.00	0.52	0.71	0.99	1.00	0.53	0.73	1.00	1.00	0.54	0.76	1.00	1.00
	AMPS*	11.61	12.30	12.79	12.88	13.45	13.98	14.34	14.38	15.29	15.68	15.92	15.93	17.19	17.45	17.58	17.58	19.17	19.33	19.38	19.38
	HI PR	268	265	262	262	311	308	304	304	358	354	350	350	409	404	401	401	464	459	456	456
	LO PR	160	147	135	133	163	149	137	136	165	151	140	139	167	154	143	143	170	156	147	147
1600	MBh†	56.66	51.35	47.06	46.92	53.70	48.71	45.06	44.99	50.67	46.00	43.04	42.98	47.54	43.20	40.91	40.85	44.26	40.27	38.62	38.57
	S/T‡	0.52	0.71	0.99	1.00	0.53	0.73	1.00	1.00	0.54	0.75	1.00	1.00	0.55	0.78	1.00	1.00	0.57	0.81	1.00	1.00
	AMPS*	11.82	12.54	13.04	13.05	13.71	14.26	14.60	14.61	15.59	16.00	16.21	16.21	17.52	17.80	17.91	17.91	19.52	19.70	19.75	19.75
	HI PR	269	266	263	263	312	308	306	306	359	355	352	352	410	405	403	403	465	460	458	458
	LO PR	164	150	139	139	166	152	142	142	168	154	146	145	170	157	149	149	173	159	153	153
1800	MBh†	57.33	51.99	48.51	48.45	54.27	49.25	46.44	46.38	51.13	46.46	44.29	44.24	47.88	43.57	42.02	41.97	44.52	40.57	39.60	39.55
	S/T‡	0.54	0.75	1.00	1.00	0.55	0.77	1.00	1.00	0.56	0.79	1.00	1.00	0.57	0.82	1.00	1.00	0.59	0.85	1.00	1.00
	AMPS*	12.06	12.80	13.23	13.24	13.99	14.56	14.84	14.85	15.91	16.33	16.49	16.50	17.86	18.15	18.23	18.24	19.89	20.07	20.10	20.11
	HI PR	270	267	264	264	313	309	307	307	360	356	354	354	411	406	404	404	466	461	460	460
	LO PR	166	153	144	144	168	155	147	147	171	157	150	150	173	159	154	154	175	161	158	158

† Total capacities are net (I.D. blower heat subtracted) system capacities based on 25' line set.

If additional tubing length and/or indoor unit is located above outdoor unit, a slight variation in capacity may occur.

†† At TVA rating indoor condition (75 °F db, 63 °F wb), all other indoor air temperatures are at 80 °F db

If additional tubing length and/or indoor unit is located above outdoor unit, a slight variation in capacity may occur.

^ System amps are total of indoor and outdoor amps.

‡ Chart data is for 80° F indoor dry bulb. For indoor db temperatures other than 80° F, measure Indoor db and Indoor CFM, and plug these into the formula below. Measure outdoor db and indoor wet bulb, apply these to the chart above, find MBh and S/T, and plug these into the formula below.

(Note: if indoor db is the only thing changing, total capacity, MBh, stays the same.)

$$\text{Sensible Capacity at Indoor db LOWER than } 80^\circ \text{ F} = (\text{MBh} \times \text{S/T}) - \left(\frac{(\text{80} - \text{Indoor db}) \times 835 \times \text{Indoor CFM}}{1000} \right)$$

$$\text{Sensible Capacity at Indoor db HIGHER than } 80^\circ \text{ F} = (\text{MBh} \times \text{S/T}) + \left(\frac{(\text{Indoor db} - 80) \times 835 \times \text{Indoor CFM}}{1000} \right)$$

COOLING		60 Size Outdoor With ED*4X60L** Indoor Cooling																								
		Outdoor Ambient Temperature – Degrees F, Dry Bulb																								
		75					85					95					105					115				
		Entering Indoor Temperature – Degrees F, Wet Bulb																								
CFM		72	67	62	57	72	67	62	57	72	67	62	57	72	67	62	57	72	67	62	57					
1750	MBh†	70.19	64.08	58.62	56.77	66.99	61.18	56.02	54.70	63.60	58.10	53.29	52.48	59.97	54.79	50.39	50.07	56.01	51.19	47.38	47.40					
	S/T‡	0.51	0.69	0.89	1.00	0.52	0.70	0.91	1.00	0.53	0.72	0.93	1.00	0.54	0.73	0.96	1.00	0.55	0.76	1.00	1.00					
	AMPS*	17.63	17.32	17.06	16.98	19.33	19.01	18.74	18.68	21.24	20.91	20.64	20.60	23.40	23.07	22.81	22.79	25.85	25.53	25.31	25.31					
	HI PR	283	278	274	273	327	322	318	317	375	370	365	364	427	422	416	416	483	477	472	472					
	LO PR	154	141	129	125	156	143	131	128	159	145	134	132	161	148	136	135	164	150	140	140					
2000	MBh†	71.45	65.28	59.93	59.08	68.09	62.22	57.26	56.84	64.55	59.00	54.51	54.45	60.76	55.56	51.85	51.85	56.65	51.83	48.98	48.99					
	S/T‡	0.53	0.72	0.93	1.00	0.54	0.73	0.95	1.00	0.55	0.75	0.99	1.00	0.56	0.77	1.00	1.00	0.57	0.80	1.00	1.00					
	AMPS*	18.11	17.79	17.53	17.49	19.81	19.48	19.22	19.19	21.72	21.38	21.12	21.12	23.87	23.53	23.31	23.31	26.31	25.99	25.82	25.82					
	HI PR	284	280	276	275	329	324	319	319	377	371	367	367	429	423	419	419	484	478	475	475					
	LO PR	157	144	133	131	160	146	135	134	162	148	138	137	164	151	141	141	167	153	145	145					
2250	MBh†	72.38	66.14	61.11	60.98	68.90	62.97	58.59	58.59	65.23	59.65	56.05	56.05	61.32	56.11	53.30	53.30	57.08	52.28	50.26	50.27					
	S/T‡	0.54	0.75	0.97	1.00	0.55	0.76	1.00	1.00	0.56	0.79	1.00	1.00	0.58	0.81	1.00	1.00	0.59	0.84	1.00	1.00					
	AMPS*	18.58	18.24	18.00	17.99	20.27	19.93	19.70	19.70	22.18	21.83	21.62	21.62	24.33	23.99	23.81	23.81	26.76	26.44	26.31	26.31					
	HI PR	285	280	277	277	330	325	321	321	378	372	369	369	430	424	421	421	485	479	477	477					
	LO PR	160	147	136	136	162	149	139	139	164	151	142	142	167	153	146	146	169	156	150	150					

† Total capacities are net (I.D. blower heat subtracted) system capacities based on 25' line set.
If additional tubing length and/or indoor unit is located above outdoor unit, a slight variation in capacity may occur.

†† At TVA rating indoor condition (75 °F db, 63 °F wb), all other indoor air temperatures are at 80 °F db
If additional tubing length and/or indoor unit is located above outdoor unit, a slight variation in capacity may occur.

^ System amps are total of indoor and outdoor amps.

‡ Chart data is for 80° F indoor dry bulb. For indoor db temperatures other than 80° F, measure Indoor db and Indoor CFM, and plug these into the formula below. Measure outdoor db and indoor wet bulb, apply these to the chart above, find MBh and S/T, and plug these into the formula below.
(Note: if indoor db is the only thing changing, total capacity, MBh, stays the same.)

$$\text{Sensible Capacity at Indoor db LOWER than } 80^\circ\text{F} = (\text{MBh} \times \text{S/T}) - \left(\frac{(80 - \text{Indoor db}) \times 835 \times \text{Indoor CFM}}{1000} \right)$$

$$\text{Sensible Capacity at Indoor db HIGHER than } 80^\circ\text{F} = (\text{MBh} \times \text{S/T}) + \left(\frac{(\text{Indoor db} - 80) \times 835 \times \text{Indoor CFM}}{1000} \right)$$

Data for Condenser Only (Cooling)									
Saturated Suction Temperature °F		Condenser Entering Air Temperature °F							
		55	65	75	85	95	105	115	125
N4A418AKA, N4A418GKA									
30	TCG	16.80	15.70	14.70	13.80	12.80	11.80	10.80	9.70
	SDT	66.70	76.10	85.40	94.80	104.30	113.70	123.20	132.70
	KW	0.78	0.90	1.03	1.18	1.34	1.53	1.72	1.94
35	TCG	18.60	17.40	16.40	15.30	14.20	13.20	12.00	10.90
	SDT	67.90	77.10	86.40	95.80	105.10	114.50	124.00	133.40
	KW	0.77	0.89	1.02	1.17	1.34	1.52	1.72	1.94
40	TCG	20.50	19.30	18.10	16.90	15.80	14.60	13.40	12.10
	SDT	69.10	78.30	87.50	96.80	106.10	115.40	124.80	134.10
	KW	0.76	0.88	1.01	1.16	1.33	1.51	1.72	1.94
45	TCG	22.60	21.30	20.00	18.70	17.40	16.10	14.80	13.40
	SDT	70.40	79.50	88.60	97.80	107.00	116.30	125.60	134.90
	KW	0.74	0.86	1.00	1.15	1.32	1.50	1.71	1.94
50	TCG	24.80	23.40	22.00	20.60	19.20	17.80	16.30	14.80
	SDT	71.80	80.70	89.80	98.90	108.00	117.20	126.40	135.60
	KW	0.73	0.85	0.99	1.14	1.31	1.49	1.70	1.93
55	TCG	27.20	25.60	24.10	22.50	21.00	19.40	17.90	33.70
	SDT	73.20	82.10	91.00	100.10	109.10	118.20	127.30	130.60
	KW	0.72	0.84	0.98	1.13	1.30	1.48	1.69	1.77
N4A424AKB, N4A424GKB									
30	TCG	20.90	19.70	18.60	17.40	16.20	15.00	13.70	12.40
	SDT	66.60	76.10	85.60	95.10	104.70	114.20	123.80	133.40
	KW	0.99	1.14	1.30	1.48	1.68	1.90	2.14	2.40
35	TCG	23.00	21.80	20.60	19.30	18.00	16.70	15.30	13.80
	SDT	67.70	77.10	86.60	96.00	105.50	115.00	124.60	134.10
	KW	1.00	1.14	1.30	1.48	1.68	1.90	2.15	2.41
40	TCG	25.40	24.00	22.70	21.30	19.90	18.50	17.00	15.40
	SDT	68.80	78.20	87.60	97.00	106.40	115.80	125.30	134.80
	KW	1.00	1.14	1.30	1.48	1.69	1.91	2.15	2.42
45	TCG	27.80	26.40	24.90	23.50	22.00	20.40	18.80	17.10
	SDT	70.00	79.30	88.60	98.00	107.30	116.70	126.10	135.60
	KW	1.00	1.14	1.31	1.49	1.69	1.91	2.15	2.42
50	TCG	30.50	29.00	27.40	25.80	24.20	22.50	20.80	18.90
	SDT	71.30	80.50	89.80	99.00	108.30	117.60	127.00	136.30
	KW	1.00	1.15	1.31	1.49	1.69	1.91	2.16	2.43
55	TCG	33.40	31.70	30.00	28.30	26.50	24.70	22.90	20.90
	SDT	72.60	81.80	90.90	100.10	109.30	118.60	127.80	137.10
	KW	1.01	1.15	1.31	1.49	1.69	1.92	2.16	2.43

TCG = Gross Cooling Capacity (x 1000 BTU/hr)
 SDT = Saturated Temperature Leaving Compressor
 kW = Outdoor Unit Kilowatts

Data for Condenser Only (Cooling)									
Saturated Suction Temperature °F		Condenser Entering Air Temperature °F							
		55	65	75	85	95	105	115	125
N4A430AKB, N4A430GKB									
30	TCG	27.40	25.90	24.50	22.90	21.30	19.70	18.00	16.20
	SDT	68.50	77.80	87.20	96.60	106.00	115.40	124.90	134.30
	KW	1.25	1.43	1.63	1.85	2.09	2.35	2.63	2.93
35	TCG	30.20	28.60	27.00	25.30	23.60	21.90	20.00	18.00
	SDT	69.70	78.90	88.30	97.60	106.90	116.30	125.70	135.00
	KW	1.26	1.43	1.63	1.85	2.10	2.36	2.65	2.95
40	TCG	33.10	31.40	29.70	27.90	26.00	24.10	22.20	20.10
	SDT	70.90	80.10	89.40	98.60	107.90	117.20	126.50	135.80
	KW	1.26	1.44	1.64	1.86	2.10	2.37	2.66	2.97
45	TCG	36.20	34.40	32.50	30.60	28.60	26.50	24.40	22.10
	SDT	72.20	81.30	90.50	99.70	108.90	118.20	127.40	136.60
	KW	1.27	1.44	1.64	1.86	2.11	2.38	2.67	2.98
50	TCG	39.60	37.60	35.50	33.40	31.20	29.00	26.70	24.20
	SDT	73.60	82.60	91.70	100.90	110.00	119.20	128.30	137.40
	KW	1.27	1.45	1.65	1.87	2.12	2.39	2.68	3.00
55	TCG	43.00	40.80	38.60	36.30	33.90	31.50	29.00	26.40
	SDT	75.00	84.00	93.00	102.00	111.10	120.20	129.20	138.20
	KW	1.28	1.46	1.66	1.88	2.12	2.39	2.69	3.00
N4A436AKA, N4A436GKA									
30	TCG	33.70	31.90	30.00	28.00	26.00	23.90	21.70	19.40
	SDT	72.00	81.70	91.30	101.00	110.70	120.50	130.40	140.60
	KW	1.50	1.71	1.94	2.20	2.48	2.79	3.11	3.46
35	TCG	37.10	35.20	33.10	31.10	28.90	26.70	24.30	21.80
	SDT	73.40	83.00	92.60	102.20	111.90	121.70	131.60	141.70
	KW	1.51	1.72	1.96	2.22	2.50	2.81	3.15	3.52
40	TCG	40.90	38.70	36.60	34.30	32.00	29.60	27.10	24.40
	SDT	74.60	84.30	93.90	103.50	113.10	122.90	132.70	142.80
	KW	1.52	1.74	1.97	2.23	2.52	2.84	3.19	3.56
45	TCG	44.80	42.50	40.20	37.80	35.40	32.80	30.10	27.20
	SDT	76.00	85.70	95.30	104.80	114.40	124.00	133.80	143.80
	KW	1.53	1.75	1.99	2.25	2.54	2.86	3.22	3.60
50	TCG	49.10	46.70	44.20	41.60	39.00	36.20	33.30	30.20
	SDT	77.30	87.00	96.70	106.10	115.60	125.20	134.90	144.80
	KW	1.54	1.76	2.00	2.27	2.56	2.88	3.24	3.63
55	TCG	53.70	51.10	48.40	45.60	42.80	39.80	36.70	33.40
	SDT	78.60	88.40	98.00	107.50	116.90	126.50	136.00	145.70
	KW	1.55	1.77	2.02	2.28	2.58	2.90	3.26	3.66

TCG = Gross Cooling Capacity (x 1000 BTU/hr)
 SDT = Saturated Temperature Leaving Compressor
 kW = Outdoor Unit Kilowatts

Data for Condenser Only (Cooling)									
Saturated Suction Temperature °F		Condenser Entering Air Temperature °F							
		55	65	75	85	95	105	115	125
N4A442AKB, N4A442GKB									
30	TCG	37.40	35.70	33.80	31.80	29.70	27.40	25.00	22.50
	SDT	68.10	77.60	87.00	96.40	105.80	115.20	124.60	133.90
	KW	1.78	1.96	2.18	2.43	2.72	3.06	3.44	3.86
35	TCG	41.30	39.40	37.40	35.10	32.80	30.30	27.70	25.00
	SDT	69.40	78.80	88.10	97.50	106.90	116.20	125.40	134.70
	KW	1.79	1.97	2.19	2.44	2.74	3.07	3.45	3.87
40	TCG	45.60	43.40	41.10	38.70	36.10	33.40	30.60	27.60
	SDT	70.80	80.10	89.40	98.60	107.90	117.20	126.40	135.50
	KW	1.80	1.98	2.20	2.46	2.75	3.09	3.47	3.89
45	TCG	50.10	47.70	45.20	42.50	39.70	36.70	33.60	30.30
	SDT	72.30	81.40	90.60	99.80	109.00	118.20	127.30	136.30
	KW	1.81	2.00	2.22	2.48	2.78	3.11	3.49	3.91
50	TCG	55.00	52.30	49.40	46.50	43.40	40.10	36.70	33.10
	SDT	73.80	82.90	92.00	101.10	110.20	119.30	128.30	137.20
	KW	1.82	2.01	2.24	2.50	2.80	3.14	3.51	3.93
55	TCG	60.10	57.10	53.90	50.70	47.30	43.70	40.00	36.10
	SDT	75.40	84.40	93.40	102.40	111.40	120.40	129.30	138.10
	KW	1.82	2.03	2.26	2.52	2.83	3.16	3.54	3.96
N4A448AKB, N4A448GKB									
30	TCG	45.00	42.40	39.90	37.40	34.90	32.30	29.50	26.40
	SDT	70.30	79.50	88.90	98.20	107.60	116.90	126.20	135.40
	KW	2.04	2.41	2.75	3.08	3.44	3.84	4.32	4.89
35	TCG	49.80	46.80	44.00	41.20	38.50	35.60	32.60	29.30
	SDT	71.70	80.90	90.10	99.40	108.70	118.00	127.20	136.30
	KW	1.99	2.39	2.75	3.10	3.47	3.87	4.34	4.90
40	TCG	54.90	51.50	48.40	45.30	42.20	39.10	35.80	32.30
	SDT	73.20	82.40	91.50	100.70	109.90	119.00	128.20	137.20
	KW	1.93	2.36	2.75	3.12	3.50	3.91	4.38	4.92
45	TCG	60.40	56.60	53.00	49.60	46.20	42.80	39.30	35.50
	SDT	74.80	83.90	92.90	102.00	111.10	120.20	129.20	138.10
	KW	1.86	2.33	2.75	3.14	3.53	3.95	4.41	4.94
50	TCG	66.20	62.00	58.00	54.20	50.50	46.70	42.90	38.70
	SDT	76.40	85.50	94.50	103.40	112.40	121.40	130.30	139.10
	KW	1.78	2.28	2.73	3.15	3.56	3.99	4.45	4.98
55	TCG	72.40	67.70	63.20	59.10	55.00	50.90	46.70	42.10
	SDT	78.20	87.10	96.10	104.90	113.80	122.60	131.40	140.10
	KW	1.68	2.23	2.71	3.16	3.59	4.02	4.49	5.01

TCG = Gross Cooling Capacity (x 1000 BTU/hr)

SDT = Saturated Temperature Leaving Compressor

KW = Outdoor Unit Kilowatts

Data for Condenser Only (Cooling)									
Saturated Suction Temperature °F		Condenser Entering Air Temperature °F							
		55	65	75	85	95	105	115	125
N4A449AKB, N4A449GKB									
30	TCG	45.60	43.20	40.80	38.40	35.90	33.20	30.40	27.50
	SDT	67.20	76.60	86.10	95.50	104.90	114.30	123.60	132.90
	KW	1.94	2.24	2.52	2.80	3.10	3.44	3.81	4.25
35	TCG	50.40	47.80	45.10	42.40	39.60	36.70	33.70	30.50
	SDT	68.50	77.80	87.10	96.50	105.80	115.10	124.40	133.60
	KW	1.87	2.20	2.50	2.80	3.12	3.46	3.83	4.27
40	TCG	55.80	52.70	49.70	46.70	43.60	40.50	37.20	33.70
	SDT	69.80	79.00	88.30	97.50	106.80	116.00	125.20	134.40
	KW	1.77	2.12	2.46	2.78	3.12	3.47	3.85	4.28
45	TCG	61.60	58.20	54.80	51.40	48.00	44.50	40.90	37.00
	SDT	71.20	80.30	89.50	98.60	107.80	117.00	126.10	135.20
	KW	1.62	2.02	2.38	2.74	3.10	3.47	3.86	4.30
50	TCG	67.90	64.10	60.30	56.50	52.70	48.80	44.80	40.60
	SDT	72.60	81.70	90.70	99.80	108.90	118.00	127.10	136.10
	KW	1.43	1.87	2.28	2.67	3.05	3.45	3.86	4.31
55	TCG	74.80	70.40	66.20	62.00	57.70	53.40	48.90	44.30
	SDT	74.20	83.10	92.10	101.10	110.10	119.10	128.10	137.00
	KW	1.20	1.68	2.13	2.56	2.98	3.41	3.85	4.31
N4A460AKB, N4A460GKB									
30	TCG	54.80	52.00	49.20	46.20	43.10	39.90	36.40	32.70
	SDT	72.60	81.60	90.60	99.70	108.80	117.90	126.90	135.90
	KW	2.54	2.85	3.18	3.55	3.97	4.45	5.01	5.67
35	TCG	60.40	57.30	54.20	50.90	47.60	44.00	40.20	36.20
	SDT	74.40	83.20	92.10	101.10	110.10	119.10	128.00	136.90
	KW	2.58	2.89	3.22	3.59	4.01	4.50	5.06	5.70
40	TCG	66.40	63.00	59.50	56.00	52.30	48.40	44.30	39.80
	SDT	76.20	84.90	93.80	102.60	111.50	120.40	129.20	138.00
	KW	2.63	2.94	3.28	3.65	4.07	4.55	5.11	5.74
45	TCG	72.90	69.10	65.20	61.30	57.30	53.00	48.50	43.60
	SDT	78.20	86.80	95.50	104.20	113.00	121.70	130.40	139.10
	KW	2.69	3.00	3.34	3.71	4.13	4.61	5.16	5.79
50	TCG	79.70	75.50	71.30	67.00	62.50	57.90	52.90	47.60
	SDT	80.30	88.70	97.20	105.90	114.50	123.10	131.70	140.20
	KW	2.75	3.07	3.41	3.78	4.20	4.68	5.22	5.84
55	TCG	87.00	82.40	77.70	73.00	68.10	63.00	57.50	51.70
	SDT	82.50	90.80	99.20	107.60	116.10	124.60	133.10	141.40
	KW	2.83	3.15	3.49	3.86	4.28	4.75	5.29	5.90

TCG = Gross Cooling Capacity (x 1000 BTU/hr)
 SDT = Saturated Temperature Leaving Compressor
 kW = Outdoor Unit Kilowatts

COOLING Multiplying Factors for other Indoor Combinations

Indoor Model	Furnace Model	Capac. (MBh)	Power (AMPS)	Indoor Model	Furnace Model	Capac. (MBh)	Power (AMPS)	Indoor Model	Furnace Model	Capac. (MBh)	Power (AMPS)
N4A418											
>ED*4X24B**		1.00	1.00	ED*4X24F**	*9MPV040	1.03	0.91	EHD4X24A**	*9MPV040	1.03	0.95
ED*4X18B**	MV08B15**B*	0.98	0.87	ED*4X24F**	*9MPV060	1.03	0.91	EHD4X24A**	*9MPV060	1.03	0.91
ED*4X18B**		0.98	1.03	ED*4X30B**	*8MPV050	1.03	0.91	EMA4X24D**		1.00	1.00
ED*4X18B**	*8MPV050	0.99	0.91	ED*4X30F**	*8MPV050	1.03	0.91	FEM4X18****		1.00	0.92
ED*4X24B**	MV08B15**B*	0.99	0.88	ED*4X30F**	*9MPV050	1.03	0.91	FEM4X24****		1.01	0.97
ED*4X24B**	*8MPV050	1.02	0.90	EHD4X24A**	MV08B15**B*	0.99	0.88	FS(M,U)4X18****		0.98	1.01
ED*4X24F**		1.00	1.00	EHD4X24A**		1.00	1.00	FS(M,U)4X24****		0.99	1.02
ED*4X24F**	*8MPV050	1.03	0.91	EHD4X24A**	*8MPV050	1.02	0.90	FSA4X24**A*		0.99	1.02
ED*4X24F**	*9MPV050	1.03	0.91	EHD4X24A**	*9MPV050	1.03	0.91	FVM4X24****		1.01	0.93
ED*4X24F**	*9MPV075	1.03	0.91	EHD4X24A**	*9MPV075	1.03	0.91				
N4A424											
>ED*4X24B**		1.00	1.00	ED*4X36F**	*9MPV060	1.03	0.92	EHD4X30A**	*9MPV040	1.02	0.92
ED*4X24B**	*8MPV050	1.01	0.94	ED*4X36J**	*8MPV075	1.03	0.93	EHD4X30A**	*9MPV060	1.03	0.92
ED*4X24B**	MV08B15**B*	1.00	0.90	ED*4X36J**	*9MPV050	1.02	0.92	EHD4X30A**	*9MPV080	1.03	0.93
ED*4X24F**	*8MPV075	1.02	0.92	ED*4X36J**	*9MPV075	1.02	0.92	EHD4X30A**	*9MPV100	1.03	0.93
ED*4X24F**	*9MPV050	1.00	0.94	ED*4X36J**	*9MPV125	1.04	0.92	EHD4X30A**	MV08B15**B*	1.01	0.89
ED*4X24F**	*9MPV075	1.01	0.94	ED*4X36J**	*9MPV040	1.02	0.92	EHD4X30A**	MV12F19**B*	1.01	0.89
ED*4X24F**	*9MPV040	1.00	0.94	ED*4X36J**	*9MPV060	1.02	0.92	EHD4X30A**		1.01	0.98
ED*4X24F**	*9MPV060	1.01	0.94	EHD4X24A**	*8MPV050	1.01	0.94	EHD4X36A**	*8MPV050	1.03	0.93
ED*4X24F**	MV12F19**B*	1.00	0.89	EHD4X24A**	*8MPV075	1.02	0.92	EHD4X36A**	*8MPV075	1.03	0.92
ED*4X24F**		1.00	1.00	EHD4X24A**	*8MPV100	1.03	0.92	EHD4X36A**	*8MPV100	1.05	0.93
ED*4X24F**	*8MPV050	1.01	0.94	EHD4X24A**	*8MPV125	1.03	0.92	EHD4X36A**	*8MPV125	1.04	0.90
ED*4X30B**	*8MPV050	1.03	0.96	EHD4X24A**	*9MPV050	1.00	0.94	EHD4X36A**	*9MPV050	1.02	0.92
ED*4X30B**	MV08B15**B*	1.01	0.89	EHD4X24A**	*9MPV075	1.00	0.94	EHD4X36A**	*9MPV075	1.02	0.92
ED*4X30B**		1.01	0.98	EHD4X24A**	*9MPV100	1.02	0.95	EHD4X36A**	*9MPV100	1.03	0.92
ED*4X30F**	*8MPV050	1.02	0.95	EHD4X24A**	*9MPV125	1.02	0.92	EHD4X36A**	*9MPV125	1.03	0.92
ED*4X30F**	*8MPV075	1.03	0.93	EHD4X24A**	*9MPV040	1.00	0.94	EHD4X36A**	*9MPV040	1.02	0.92
ED*4X30F**	*9MPV050	1.02	0.92	EHD4X24A**	*9MPV060	1.01	0.94	EHD4X36A**	*9MPV060	1.03	0.93
ED*4X30F**	*9MPV075	1.02	0.92	EHD4X24A**	*9MPV080	1.03	0.92	EHD4X36A**	*9MPV080	1.06	0.94
ED*4X30F**	*9MPV040	1.02	0.92	EHD4X24A**	*9MPV100	1.02	0.92	EHD4X36A**	*9MPV100	1.04	0.92

> Indicates Tested Indoor Model

- continued on next page -

COOLING Multiplying Factors for other Indoor Combinations (continued)

Indoor Model	Furnace Model	Capac. (MBh)	Power (AMPS)	Indoor Model	Furnace Model	Capac. (MBh)	Power (AMPS)	Indoor Model	Furnace Model	Capac. (MBh)	Power (AMPS)
ED*4X30F**	*9MVX060	1.03	0.92	EHD4X24A**	MV08B15**B*	1.01	0.89	EMA4X24D**		1.00	1.00
ED*4X30F**	MV12F19**B*	1.01	0.89	EHD4X24A**	MV12F19**B*	1.00	0.89	FEM4X24****		1.01	0.94
ED*4X30F**		1.01	0.98	EHD4X24A**		1.00	1.00	FEM4X30****		1.02	0.92
ED*4X36B**	*8MPV050	1.02	0.95	EHD4X30A**	*8MPV050	1.03	0.96	FS(M,U)4X24****		0.99	0.99
ED*4X36F**	*8MPV050	1.02	0.92	EHD4X30A**	*8MPV075	1.03	0.93	FS(M,U)4X30****		1.00	0.98
ED*4X36F**	*8MPV075	1.02	0.92	EHD4X30A**	*8MPV100	1.04	0.92	FSA4X24**A*		0.98	1.03
ED*4X36F**	*8MPV100	1.04	0.92	EHD4X30A**	*8MPV125	1.04	0.92	FSA4X30**A*		0.98	1.03
ED*4X36F**	*9MPV050	1.01	0.91	EHD4X30A**	*9MPV050	1.02	0.92	FVM4X24****		1.01	0.89
ED*4X36F**	*9MPV075	1.02	0.92	EHD4X30A**	*9MPV075	1.02	0.92	FVM4X36****		1.02	0.90
ED*4X36F**	*9MPV100	1.03	0.92	EHD4X30A**	*9MPV100	1.03	0.93				
ED*4X36F**	*9MVX040	1.01	0.91	EHD4X30A**	*9MPV125	1.03	0.93				
N4A430											
>ED*4X30B**		1.00	1.00	ED*4X42F**	*9MVX040	0.99	0.93	EHD4X36A**	*8MPV125	1.02	0.92
ED*4X30B**	*8MPV050	1.00	0.98	ED*4X42F**	*9MVX060	0.99	0.93	EHD4X36A**	*9MPV050	1.00	0.96
ED*4X30B**	MV08B15**B*	1.00	0.94	ED*4X42J**	*8MPV075	1.00	0.94	EHD4X36A**	*9MPV075	1.00	0.96
ED*4X30F**	*8MPV075	1.01	0.94	ED*4X42J**	*8MPV100	1.00	0.90	EHD4X36A**	*9MPV100	1.02	0.96
ED*4X30F**	*9MPV050	0.99	0.95	ED*4X42J**	*8MPV125	1.00	0.90	EHD4X36A**	*9MPV125	1.03	0.92
ED*4X30F**	*9MPV075	1.00	0.96	ED*4X42J**	*9MPV050	0.99	0.93	EHD4X36A**	*9MVX040	1.00	0.96
ED*4X30F**	*9MVX040	0.99	0.95	ED*4X42J**	*9MPV075	1.00	0.94	EHD4X36A**	*9MVX060	1.00	0.96
ED*4X30F**	*9MVX060	1.00	0.96	ED*4X42J**	*9MPV100	1.00	0.94	EHD4X36A**	*9MVX080	1.00	0.90
ED*4X30F**	MV12F19**B*	1.01	0.91	ED*4X42J**	*9MPV125	1.00	0.90	EHD4X36A**	*9MVX100	1.00	0.90
ED*4X30F**		1.00	1.00	ED*4X42J**	*9MVX040	0.99	0.92	EHD4X36A**	MV08B15**B*	1.01	0.91
ED*4X30F**	*8MPV050	0.98	0.95	ED*4X42J**	*9MVX060	1.00	0.94	EHD4X36A**	MV12F19**B*	1.01	0.91
ED*4X36B**	*8MPV050	0.97	0.95	ED*4X42J**	*9MVX080	1.00	0.94	EHD4X36A**		1.01	1.01
ED*4X36B**	MV08B15**B*	0.98	0.88	ED*4X42L**	*8MPV100	1.00	0.90	EHD4X42A**	*8MPV050	1.00	0.98
ED*4X36B**		0.98	0.98	ED*4X42L**	*8MPV125	1.00	0.90	EHD4X42A**	*8MPV075	0.99	0.89
ED*4X36F**	*8MPV075	1.01	0.95	ED*4X42L**	*9MPV100	1.00	0.90	EHD4X42A**	*8MPV100	1.00	0.90
ED*4X36F**	*9MPV050	1.00	0.96	ED*4X42L**	*9MPV125	1.00	0.90	EHD4X42A**	*8MPV125	1.00	0.90
ED*4X36F**	*9MPV075	1.00	0.96	ED*4X42L**	*9MVX080	1.00	0.90	EHD4X42A**	*9MPV050	1.00	0.94
ED*4X36F**	*9MVX040	1.00	0.96	ED*4X42L**	*9MVX100	0.99	0.89	EHD4X42A**	*9MPV075	1.00	0.94
ED*4X36F**	*9MVX060	1.00	0.96	EHD4X30A**	*8MPV050	1.00	0.98	EHD4X42A**	*9MPV100	1.00	0.90

> Indicates Tested Indoor Model

- continued on next page -

COOLING Multiplying Factors for other Indoor Combinations (continued)

Indoor Model	Furnace Model	Capac. (MBh)	Power (AMPS)	Indoor Model	Furnace Model	Capac. (MBh)	Power (AMPS)	Indoor Model	Furnace Model	Capac. (MBh)	Power (AMPS)
ED*4X36F**	MV12F19**B*	1.01	0.91	EHD4X30A**	*8MPV075	1.01	0.94	EHD4X42A**	*9MPV125	1.00	0.90
ED*4X36F**		1.01	1.01	EHD4X30A**	*8MPV100	1.01	0.94	EHD4X42A**	*9MVX040	0.99	0.93
ED*4X36F**	*8MPV050	0.98	0.95	EHD4X30A**	*8MPV125	1.01	0.94	EHD4X42A**	*9MVX060	1.00	0.94
ED*4X36J**	*8MPV100	1.02	0.92	EHD4X30A**	*9MPV050	0.99	0.95	EHD4X42A**	*9MVX080	1.00	0.90
ED*4X36J**	*8MPV125	1.02	0.92	EHD4X30A**	*9MPV075	1.00	0.96	EHD4X42A**	*9MVX100	1.00	0.90
ED*4X36J**	*9MPV100	1.02	0.96	EHD4X30A**	*9MPV100	1.01	0.94	EMA4X36D**		1.00	1.00
ED*4X36J**	*9MVX080	1.00	0.90	EHD4X30A**	*9MPV125	1.01	0.94	FEM4X30****		1.01	0.94
ED*4X36J**		1.01	1.01	EHD4X30A**	*9MVX040	0.99	0.95	FEM4X36****		1.03	0.96
ED*4X36J**	*8MPV075	0.99	0.93	EHD4X30A**	*9MVX060	1.00	0.96	FS(M,U)4X30****		0.99	0.99
ED*4X36J**	*9MPV050	0.99	0.96	EHD4X30A**	*9MVX080	1.00	0.94	FSA4X30**A*		0.99	0.99
ED*4X36J**	*9MPV075	0.99	0.93	EHD4X30A**	*9MVX100	1.00	0.94	FSA4X36**A*		1.01	1.01
ED*4X36J**	*9MVX040	0.98	0.92	EHD4X30A**	MV08B15**B*	1.00	0.90	FSM4X36****		1.02	1.00
ED*4X36J**	*9MVX060	0.99	0.93	EHD4X30A**	MV12F19**B*	1.01	0.91	FVM4X24****		1.00	0.94
ED*4X42F**	*8MPV050	1.00	0.98	EHD4X30A**		1.00	1.00	FVM4X36****		1.01	0.91
ED*4X42F**	*8MPV075	1.00	0.94	EHD4X36A**	*8MPV050	1.00	0.98	FVM4X48****		1.03	0.92
ED*4X42F**	*9MPV050	0.99	0.93	EHD4X36A**	*8MPV075	1.01	0.95				
ED*4X42F**	*9MPV075	0.99	0.93	EHD4X36A**	*8MPV100	1.02	0.92				
N4A436											
>ED*4X42J**		1.00	1.00	ED*4X42L**	*9MVX080	1.00	0.96	EHD4X36A**		0.99	0.99
ED*4X36B**	MV08B15**B*	0.99	0.95	ED*4X48F**	*9MVX040	1.01	0.99	EHD4X42A**	*8MPV050	1.01	1.01
ED*4X36B**		0.95	0.95	ED*4X48F**	*8MPV075	1.01	0.97	EHD4X42A**	*8MPV075	1.01	1.01
ED*4X36F**	*8MPV075	0.99	0.99	ED*4X48F**	*8MPV100	1.02	0.94	EHD4X42A**	*8MPV100	1.01	1.01
ED*4X36F**	*9MVX040	0.98	0.98	ED*4X48F**	*8MPV125	1.02	0.94	EHD4X42A**	*8MPV125	1.01	0.97
ED*4X36F**	*9MVX060	0.98	0.97	ED*4X48F**	*9MPV050	0.99	0.99	EHD4X42A**	*9MPV050	1.01	1.01
ED*4X36F**	MV12F19**B*	0.99	0.91	ED*4X48F**	*9MPV075	1.00	1.00	EHD4X42A**	*9MPV075	1.01	1.01
ED*4X36F**		0.99	0.99	ED*4X48F**	*9MPV100	1.01	0.97	EHD4X42A**	*9MPV100	1.01	1.01
ED*4X36F**	*8MPV050	0.97	0.97	ED*4X48F**	*9MVX040	0.99	0.99	EHD4X42A**	*9MPV125	1.01	1.01
ED*4X36J**	*8MPV100	1.00	1.00	ED*4X48F**	*9MVX060	1.01	0.97	EHD4X42A**	*9MVX040	0.98	0.98
ED*4X36J**	*8MPV125	1.00	1.00	ED*4X48F**	*9MVX080	1.01	0.97	EHD4X42A**	*9MVX060	0.99	0.98
ED*4X36J**	*9MPV100	0.99	0.99	ED*4X48J**	*8MPV075	1.00	0.96	EHD4X42A**	*9MVX080	1.01	0.99
ED*4X36J**	*9MVX080	1.00	0.98	ED*4X48J**	*8MPV100	1.01	0.93	EHD4X42A**	*9MVX100	1.01	0.97

> Indicates Tested Indoor Model

- continued on next page -

COOLING Multiplying Factors for other Indoor Combinations (continued)

Indoor Model	Furnace Model	Capac. (MBh)	Power (AMPS)	Indoor Model	Furnace Model	Capac. (MBh)	Power (AMPS)	Indoor Model	Furnace Model	Capac. (MBh)	Power (AMPS)
ED*4X36J**	MV16J22**B*	0.99	0.91	ED*4X48J**	*8MPV125	1.01	0.93	EHD4X42A**	MV08B15**B*	0.99	0.92
ED*4X36J**		0.99	0.99	ED*4X48J**	*9MPV050	0.99	0.99	EHD4X42A**	MV12F19**B*	0.99	0.92
ED*4X36J**	*8MPV075	0.99	0.95	ED*4X48J**	*9MPV075	0.99	0.95	EHD4X42A**	MV16J22**B*	0.99	0.92
ED*4X36J**	*9MPV050	0.98	0.98	ED*4X48J**	*9MPV100	1.01	0.97	EHD4X42A**	MV20L24**B*	0.99	0.92
ED*4X36J**	*9MPV075	0.98	0.98	ED*4X48J**	*9MPV125	1.01	0.93	EHD4X42A**		1.00	1.00
ED*4X36J**	*9MVX040	0.97	0.97	ED*4X48J**	*9MVX040	0.98	0.98	EHD4X48A**	*9MVX040	1.01	0.99
ED*4X36J**	*9MVX060	0.98	0.98	ED*4X48J**	*9MVX060	1.00	0.96	EHD4X48A**	*8MPV050	0.99	0.99
ED*4X42F**	*9MVX040	0.98	0.98	ED*4X48J**	*9MVX080	1.01	0.97	EHD4X48A**	*8MPV075	1.01	0.97
ED*4X42F**	*9MVX060	0.99	0.98	ED*4X48L**	*8MPV100	1.01	0.93	EHD4X48A**	*8MPV100	1.02	0.94
ED*4X42F**	*8MPV050	0.98	0.98	ED*4X48L**	*8MPV125	1.01	0.93	EHD4X48A**	*8MPV125	1.02	0.94
ED*4X42J**	*8MPV100	1.01	1.01	ED*4X48L**	*9MPV100	1.01	0.97	EHD4X48A**	*9MPV050	1.00	1.00
ED*4X42J**	*8MPV125	1.01	1.01	ED*4X48L**	*9MPV125	1.01	0.93	EHD4X48A**	*9MPV075	1.00	0.96
ED*4X42J**	*9MPV100	1.01	1.01	ED*4X48L**	*9MVX080	1.01	0.97	EHD4X48A**	*9MPV100	1.01	0.93
ED*4X42J**	*9MVX080	1.01	0.99	ED*4X48L**	*9MVX100	1.01	0.93	EHD4X48A**	*9MPV125	1.02	0.94
ED*4X42J**	MV16J22**B*	0.99	0.92	EHD4X36A**	*8MPV075	0.99	0.99	EHD4X48A**	*9MVX040	1.00	1.00
ED*4X42J**	*8MPV075	0.99	0.95	EHD4X36A**	*8MPV100	0.99	0.99	EHD4X48A**	*9MVX060	1.01	0.97
ED*4X42J**	*9MPV050	0.98	0.98	EHD4X36A**	*8MPV125	0.99	0.99	EHD4X48A**	*9MVX080	1.02	0.98
ED*4X42J**	*9MPV075	0.98	0.98	EHD4X36A**	*9MPV075	0.99	0.99	EHD4X48A**	*9MVX100	1.01	0.93
ED*4X42J**	*9MVX040	0.98	0.98	EHD4X36A**	*9MPV100	0.99	0.99	EMA4X36D**		0.99	1.03
ED*4X42J**	*9MVX060	0.98	0.98	EHD4X36A**	*9MPV125	0.99	0.99	FEM4X36****		1.02	0.94
ED*4X42L**	*9MPV125	0.99	0.99	EHD4X36A**	*9MVX040	0.98	0.98	FEM4X42****		1.02	0.94
ED*4X42L**	*9MVX100	1.01	0.97	EHD4X36A**	*9MVX060	0.98	0.97	FS(M,U)4X42****		0.99	0.99
ED*4X42L**	MV20L24**B*	0.99	0.92	EHD4X36A**	*9MVX080	1.00	0.98	FSM2X36****		0.98	0.98
ED*4X42L**		1.00	1.00	EHD4X36A**	*9MVX100	1.01	0.97	FSM4X36****		0.99	0.97
ED*4X42L**	*8MPV100	1.01	0.93	EHD4X36A**	MV08B15**B*	0.99	0.91	FSU4X36****		0.97	0.98
ED*4X42L**	*8MPV125	1.01	0.93	EHD4X36A**	MV12F19**B*	0.99	0.91	FVM4X36****		0.99	0.95
ED*4X42L**	*9MPV100	1.00	0.96	EHD4X36A**	MV16J22**B*	0.99	0.91	FVM4X48****		1.02	0.94
ED*4X42L**	*9MPV125	1.00	0.96	EHD4X36A**	MV20L24**B*	0.99	0.91				
N4A442											
>ED*4X48J**		1.00	1.00	ED*4X48J**	*9MVX080	1.00	0.98	EHD4X42A**	MV16J22**B*	0.99	0.91
ED*4X42F**	*8MPV075	0.98	0.98	ED*4X48J**	MV16J22**B*	1.01	0.93	EHD4X42A**	MV20L24**B*	0.99	0.91

> Indicates Tested Indoor Model

- continued on next page -

COOLING Multiplying Factors for other Indoor Combinations (continued)

Indoor Model	Furnace Model	Capac. (MBh)	Power (AMPS)	Indoor Model	Furnace Model	Capac. (MBh)	Power (AMPS)	Indoor Model	Furnace Model	Capac. (MBh)	Power (AMPS)
ED*4X42F**	*9MPV075	0.96	0.99	ED*4X48L**	*8MPV100	1.00	0.96	EHD4X42A**		1.00	1.00
ED*4X42F**	*9MVX060	0.98	0.98	ED*4X48L**	*8MPV125	1.00	0.96	EHD4X48A**	*8MPV075	1.00	0.98
ED*4X42F**	MV12F19**B*	0.99	0.95	ED*4X48L**	*9MPV100	1.00	0.96	EHD4X48A**	*8MPV100	1.01	0.97
ED*4X42F**		0.99	1.01	ED*4X48L**	*9MPV125	1.00	0.96	EHD4X48A**	*8MPV125	1.01	0.97
ED*4X42J**	*8MPV075	0.98	0.98	ED*4X48L**	*9MVX080	1.00	0.96	EHD4X48A**	*9MPV100	1.01	1.00
ED*4X42J**	*8MPV100	0.99	0.97	ED*4X48L**	*9MVX100	1.00	0.98	EHD4X48A**	*9MPV125	1.01	0.97
ED*4X42J**	*8MPV125	0.99	0.97	ED*4X48L**	MV20L24**B*	1.01	0.93	EHD4X48A**	*9MVX060	1.00	1.00
ED*4X42J**	*9MPV075	0.98	1.02	ED*4X48L**		1.00	1.00	EHD4X48A**	*9MVX080	1.00	0.98
ED*4X42J**	*9MPV100	0.99	0.97	ED*4X60J**	*8MPV075	1.01	0.97	EHD4X48A**	*9MVX100	1.00	0.98
ED*4X42J**	*9MVX060	0.98	0.98	ED*4X60J**	*8MPV100	1.02	0.95	EHD4X48A**	MV12F19**B*	1.01	0.93
ED*4X42J**	*9MVX080	0.99	0.97	ED*4X60J**	*8MPV125	1.02	0.95	EHD4X48A**	MV16J22**B*	1.01	0.93
ED*4X42J**	MV16J22**B*	0.99	0.91	ED*4X60J**	*9MPV075	1.01	1.01	EHD4X48A**	MV20L24**B*	1.01	0.93
ED*4X42J**		0.99	1.01	ED*4X60J**	*9MPV100	1.02	0.98	EHD4X48A**		1.01	1.01
ED*4X42L**	*8MPV100	0.99	0.95	ED*4X60J**	*9MPV125	1.02	0.95	EHD4X60A**	*8MPV075	1.02	0.98
ED*4X42L**	*8MPV125	0.99	0.95	ED*4X60J**	*9MVX060	1.01	1.01	EHD4X60A**	*8MPV100	1.02	0.95
ED*4X42L**	*9MPV100	0.99	0.95	ED*4X60J**	*9MVX080	1.02	0.98	EHD4X60A**	*8MPV125	1.02	0.95
ED*4X42L**	*9MPV125	0.99	0.97	ED*4X60L**	*8MPV100	1.02	0.95	EHD4X60A**	*9MPV075	1.01	1.01
ED*4X42L**	*9MVX080	0.99	0.99	ED*4X60L**	*8MPV125	1.02	0.95	EHD4X60A**	*9MPV100	1.02	0.95
ED*4X42L**	*9MVX100	0.99	0.97	ED*4X60L**	*9MPV100	1.02	0.98	EHD4X60A**	*9MPV125	1.02	0.95
ED*4X42L**	MV20L24**B*	0.99	0.91	ED*4X60L**	*9MPV125	1.02	0.95	EHD4X60A**	*9MVX060	1.01	1.01
ED*4X42L**		0.99	1.01	ED*4X60L**	*9MVX080	1.02	0.98	EHD4X60A**	*9MVX080	1.02	0.98
ED*4X48F**	*8MPV075	0.99	0.97	ED*4X60L**	*9MVX100	1.01	0.93	EHD4X60A**	*9MVX100	1.02	0.95
ED*4X48F**	*9MVX060	1.00	1.00	EHD4X42A**	*8MPV075	1.00	0.98	EMA4X48D**		0.99	1.01
ED*4X48F**	MV12F19**B*	1.01	0.93	EHD4X42A**	*8MPV100	1.01	0.97	FEM4X42****		1.00	0.98
ED*4X48F**		1.00	1.00	EHD4X42A**	*8MPV125	1.01	0.97	FEM4X48****		1.02	0.98
ED*4X48J**	*8MPV075	1.00	1.00	EHD4X42A**	*9MPV100	1.00	0.98	FS(M,U)4X42****		0.99	1.01
ED*4X48J**	*8MPV100	1.00	0.96	EHD4X42A**	*9MPV125	1.00	0.96	FS(M,U)4X48****		1.01	1.01
ED*4X48J**	*8MPV125	1.00	0.96	EHD4X42A**	*9MVX060	0.98	0.98	FVM4X36****		0.98	0.94
ED*4X48J**	*9MPV075	0.99	0.99	EHD4X42A**	*9MVX080	0.99	0.97	FVM4X48****		1.01	0.97
ED*4X48J**	*9MPV100	1.00	0.98	EHD4X42A**	*9MVX100	0.99	0.97	FVM4X60****		1.02	0.98
ED*4X48J**	*9MVX060	0.99	0.99	EHD4X42A**	MV12F19**B*	0.99	0.91				

> Indicates Tested Indoor Model

- continued on next page -

COOLING Multiplying Factors for other Indoor Combinations (continued)

Indoor Model	Furnace Model	Capac. (MBh)	Power (AMPS)	Indoor Model	Furnace Model	Capac. (MBh)	Power (AMPS)	Indoor Model	Furnace Model	Capac. (MBh)	Power (AMPS)
N4A448											
>ED*4X60L**		1.00	1.00	ED*4X60J**	*9MPV100	1.00	0.96	EHD4X48A**		0.98	0.98
ED*4X48F**		0.97	0.97	ED*4X60J**	*9MVX080	1.00	0.96	EHD4X60A**	*8MPV100	0.99	0.95
ED*4X48J**	*8MPV100	0.97	0.94	ED*4X60J**	MV16J22**B*	1.00	0.94	EHD4X60A**	*8MPV125	0.99	0.93
ED*4X48J**	*8MPV125	0.98	0.94	ED*4X60J**		1.00	1.00	EHD4X60A**	*9MPV100	0.99	0.95
ED*4X48J**	*9MVX080	0.97	0.97	ED*4X60L**	*8MPV100	1.00	0.98	EHD4X60A**	*9MPV125	0.99	0.95
ED*4X48J**	MV16J22**B*	0.97	0.94	ED*4X60L**	*8MPV125	1.00	0.98	EHD4X60A**	*9MVX080	1.00	0.96
ED*4X48J**		0.98	1.00	ED*4X60L**	*9MPV100	0.99	0.96	EHD4X60A**	*9MVX100	0.99	0.95
ED*4X48L**	*8MPV100	0.98	0.95	ED*4X60L**	*9MPV125	0.99	0.95	EHD4X60A**	MV16J22**B*	1.00	0.90
ED*4X48L**	*8MPV125	0.98	0.95	ED*4X60L**	*9MVX080	0.99	0.96	EHD4X60A**	MV20L24**B*	1.00	0.90
ED*4X48L**	*9MPV100	0.97	0.99	ED*4X60L**	*9MVX100	0.99	0.95	EHD4X60A**		1.00	1.00
ED*4X48L**	*9MPV125	0.97	0.94	ED*4X60L**	MV20L24**B*	1.00	0.94	EMA4X48D**		0.95	0.96
ED*4X48L**	*9MVX080	0.97	0.99	EHD4X48A**	*8MPV100	0.97	0.94	FEM4X48****		1.00	0.96
ED*4X48L**	*9MVX100	0.97	0.94	EHD4X48A**	*8MPV125	0.97	0.93	FEM4X60****		1.01	0.95
ED*4X48L**	MV20L24**B*	0.97	0.91	EHD4X48A**	*9MVX080	0.97	0.97	FS(M,U)4X48****		0.99	1.01
ED*4X48L**		0.98	1.00	EHD4X48A**	*9MVX100	0.97	0.94	FS(M,U)4X60****		1.00	1.00
ED*4X60J**	*8MPV100	1.00	0.96	EHD4X48A**	MV16J22**B*	0.97	0.91	FVM4X48****		0.99	0.93
ED*4X60J**	*8MPV125	1.00	0.94	EHD4X48A**	MV20L24**B*	0.97	0.91	FVM4X60****		1.00	0.94
N4A449											
>ED*4X60L**		1.00	1.00	ED*4X48L**	MV16J22**B*	0.98	0.94	EHD4X48A**	*9MVX080	0.98	0.98
ED*4X48F**	*8MPV100	0.98	0.98	ED*4X48L**		0.98	1.02	EHD4X48A**	*9MVX100	0.98	0.98
ED*4X48F**	*8MPV125	0.98	0.98	ED*4X60J**	*8MPV100	1.00	0.96	EHD4X48A**	MV16J22**B*	0.98	0.94
ED*4X48F**	*9MPV100	0.98	0.98	ED*4X60J**	*8MPV125	1.00	0.96	EHD4X48A**		0.99	0.99
ED*4X48F**	*9MVX080	0.98	0.98	ED*4X60J**	*9MPV100	0.99	0.99	EHD4X60A**	*8MPV100	1.00	0.96
ED*4X48F**	MV16J22**B*	0.98	0.94	ED*4X60J**	*9MPV125	0.99	0.99	EHD4X60A**	*8MPV125	1.00	0.96
ED*4X48F**		0.98	0.98	ED*4X60J**	*9MVX080	0.99	0.99	EHD4X60A**	*9MPV100	1.00	1.00
ED*4X48J**	*8MPV100	0.98	0.98	ED*4X60J**	*9MVX100	0.99	0.99	EHD4X60A**	*9MPV125	1.00	0.96
ED*4X48J**	*8MPV125	0.98	0.98	ED*4X60J**	MV16J22**B*	1.00	0.96	EHD4X60A**	*9MVX080	1.00	1.00
ED*4X48J**	*9MPV100	0.97	0.97	ED*4X60J**		1.00	1.00	EHD4X60A**	*9MVX100	1.00	1.00
ED*4X48J**	*9MPV125	0.97	0.97	ED*4X60L**	*8MPV100	1.00	1.00	EHD4X60A**	MV16J22**B*	1.00	0.96

> Indicates Tested Indoor Model

- continued on next page -

COOLING Multiplying Factors for other Indoor Combinations (continued)

Indoor Model	Furnace Model	Capac. (MBh)	Power (AMPS)	Indoor Model	Furnace Model	Capac. (MBh)	Power (AMPS)	Indoor Model	Furnace Model	Capac. (MBh)	Power (AMPS)
ED*4X48J**	*9MVX080	0.97	0.97	ED*4X60L**	*8MPV125	1.00	0.96	EHD4X60A**		1.00	1.00
ED*4X48J**	*9MVX100	0.97	0.97	ED*4X60L**	*9MPV100	0.99	0.99	EMA4X48D**		0.96	0.96
ED*4X48J**	MV16J22**B*	0.98	0.94	ED*4X60L**	*9MPV125	0.99	0.99	FEM4X48****		1.00	1.00
ED*4X48J**		0.98	1.02	ED*4X60L**	*9MVX080	0.99	0.99	FEM4X60****		1.00	0.96
ED*4X48L**	*8MPV100	0.98	0.98	ED*4X60L**	*9MVX100	0.99	0.99	FS(M,U)4X48****		0.98	1.02
ED*4X48L**	*8MPV125	0.98	0.98	ED*4X60L**	MV16J22**B*	1.00	0.96	FS(M,U)4X60****		1.00	1.04
ED*4X48L**	*9MPV100	0.97	0.97	EHD4X48A**	*8MPV100	0.99	0.99	FVM4X48****		1.00	0.96
ED*4X48L**	*9MPV125	0.97	0.97	EHD4X48A**	*8MPV125	0.98	0.98	FVM4X60****		1.00	0.96
ED*4X48L**	*9MVX080	0.98	0.98	EHD4X48A**	*9MPV100	0.98	0.98				
ED*4X48L**	*9MVX100	0.97	0.97	EHD4X48A**	*9MPV125	0.98	0.98				
N4A460											
>ED*4X60L**		1.00	1.00	ED*4X60L**	*9MPV100	0.96	0.96	EHD4X60A**	*9MVX080	0.97	0.97
ED*4X60J**	*8MPV100	0.97	0.95	ED*4X60L**	*9MPV125	0.96	0.94	EHD4X60A**	*9MVX100	0.97	0.97
ED*4X60J**	*8MPV125	0.97	0.93	ED*4X60L**	*9MVX080	0.97	0.97	EHD4X60A**	MV16J22**B*	0.99	0.95
ED*4X60J**	*9MPV100	0.97	0.97	ED*4X60L**	*9MVX100	0.97	0.97	EHD4X60A**	MV20L24**B*	0.99	0.95
ED*4X60J**	*9MVX080	0.97	0.97	ED*4X60L**	MV20L24**B*	0.99	0.95	EHD4X60A**		1.00	1.00
ED*4X60J**	MV16J22**B*	0.99	0.95	EHD4X60A**	*8MPV100	0.97	0.95	FEM4X60****		1.02	1.00
ED*4X60J**		0.98	0.98	EHD4X60A**	*8MPV125	0.97	0.95	FS(M,U)4X60****		1.00	1.04
ED*4X60L**	*8MPV100	0.97	0.97	EHD4X60A**	*9MPV100	0.97	0.97	FVM4X60****		1.00	0.98
ED*4X60L**	*8MPV125	0.99	0.99	EHD4X60A**	*9MPV125	0.96	0.94				

> Indicates Tested Indoor Model

OUTDOOR UNIT MODEL NUMBER IDENTIFICATION GUIDE (single phase)											
Digit Position:	1	2	3	4	5, 6	7	8	9	10	11	12
Example Part Number:	N	4	A	4	18	A	K	A	2	0	0
Product Family	REFRIGERANT		TYPE		NOMINAL EFFICIENCY		FEATURES		VOLTAGE		
4 = R-410A											
A = Air Conditioner											
H = Heat Pump											
3 = 13 SEER											
4 = 14 SEER											
18 = 18,000 BTUH = 1½ tons											
24 = 24,000 BTUH = 2 tons											
30 = 30,000 BTUH = 2½ tons											
36 = 36,000 BTUH = 3 tons											
42 = 42,000 BTUH = 3½ tons											
48 = 48,000 BTUH = 4 tons											
60 = 60,000 BTUH = 5 tons											
A = Standard Grille											
G = Coil Guard Grille											
C = Coastal											
K = 208/230-1-60											
Sales Code											
Engineering Revision											
Extra Digit											
Extra Digit											

ACCESSORIES PART NUMBER IDENTIFICATION GUIDE									
Digit Position:	1	2	3	4	5	6, 7	8, 9	10, 11	
Example Part Number:	N	A	S	A	0	01	01	CH	
BRANDING		PRODUCT GROUP		KIT USAGE		MAJOR SERIES			
N = Non-Branded									
A = Accessory									
S = Split System (AC & HP)									
A = Original									
B = 2nd Generation									
0 = Generic or Not Applicable									
2 = R-22									
4 = R-410A									
Product Identifier Number									
Package Quantity									
Type of Kit (Example: CH = Crankcase Heater)									