

# Installation Instructions

## ACCESSORY VERTICAL POWER EXHAUST, GAS HEATING/ELECTRIC COOLING, ELECTRIC COOLING, AND HEAT PUMP UNITS

3 TO 12 1/2 TON

DNPWREXH030A01, DNPWREXH021A01 DNPWREXH023A01,  
DNPWREXH080A00, DNPWREXH081A00

For Use With Vertical Economizer

### TABLE OF CONTENTS

PACKAGE CONTENTS .....	1
UNIT CONFIGURATION TABLE .....	1
PACKAGE USAGE .....	1
SAFETY CONSIDERATIONS .....	1
GENERAL .....	1
INSTALLATION .....	2
Power Exhaust Wiring with Economizer .....	3
Attaching Power Exhaust to the Unit .....	7
Install Hinged Door Angle (Small and Large Cabinet) ...	8

**IMPORTANT:** Read these instructions completely before attempting to install the accessory power exhaust.

### PACKAGE CONTENTS

QTY	CONTENTS
1	Power Exhaust Hood/Fan Assembly <sup>1</sup>
1	Low Voltage Wiring Harness with plug and 12 in (305mm) gray jumper wire <sup>1</sup>
1	High Voltage Wiring Harness with plug <sup>1</sup>
8	No. 10 x 3/4 in. (19mm) Mounting Screws
1	Gasketing Roll
1	Sealing Angle

#### NOTES:

- Both wiring harnesses are shipped attached to the power exhaust assembly.

### UNIT CONFIGURATION TABLE

UNIT CONFIGURATION	UNIT FOOTPRINT SIZE
Small Cabinet	46 3/4" x 74 3/8"
Large Cabinet	58 1/2" x 88 1/8"
Extra Large Cabinet	63 3/8" x 115 7/8"

### PACKAGE USAGE

UNIT CONFIGURATION	POWER EXHAUST PART NUMBER	POWER EXHAUST VOLTAGE
Small Cabinet	DNPWREXH030A01	208/230 V, 1 Ph
	DNPWREXH021A01	460 V, 3 Ph
Large Cabinet	DNPWREXH022A01	208/230 V, 1 Ph
	DNPWREXH023A01	460 V, 3 Ph
Extra Large Cabinet	DNPWREXH080A00	208/230 V, 1 Ph
	DNPWREXH081A00	460 V, 3 Ph

**NOTE:** For 575-v installations, a field-supplied and installed transformer (part no. HT01AH859) must be used with 208/230 V power exhaust.

### SAFETY CONSIDERATIONS

Installation and servicing of air-conditioning equipment can be hazardous due to system pressure and electrical components. Only trained and qualified service personnel should install, repair, or service air-conditioning equipment.

Untrained personnel can perform the basic maintenance functions. All other operations should be performed by trained service personnel. When working on air-conditioning equipment, observe precautions in the literature, tags and labels attached to the unit, and other safety precautions that may apply.

Follow all safety codes. Wear safety glasses and work gloves.

Recognize safety information. This is the safety-alert symbol  $\triangle$ . When you see this symbol on the unit and in instructions or manuals, be alert to the potential for personal injury.

Understand the signal words DANGER, WARNING, and CAUTION. These words are used with the safety-alert symbol. DANGER identifies the most serious hazards which **will** result in severe personal injury or death. WARNING signifies a hazard which **could** result in personal injury or death. CAUTION is used to identify unsafe practices which **may** result in minor personal injury or product and property damage. NOTE is used to highlight suggestions which **will** result in enhanced installation, reliability, or operation.

### GENERAL

The accessory vertical power exhaust is used in conjunction with the vertical Economizer accessories. For horizontal applications, this power exhaust accessory **cannot** be used. The horizontal power exhaust accessory must be used for horizontal applications.

See Table 1 for Economizer usage. See Fig. 1 for dimensions.

**Table 1 – Accessory Vertical Economizer Use**

PART NO.	DESCRIPTION
DNECOMZR020A02	Economizer with W7212 controller.
DNECOMZR021A03	
DNECOMZR062A00	

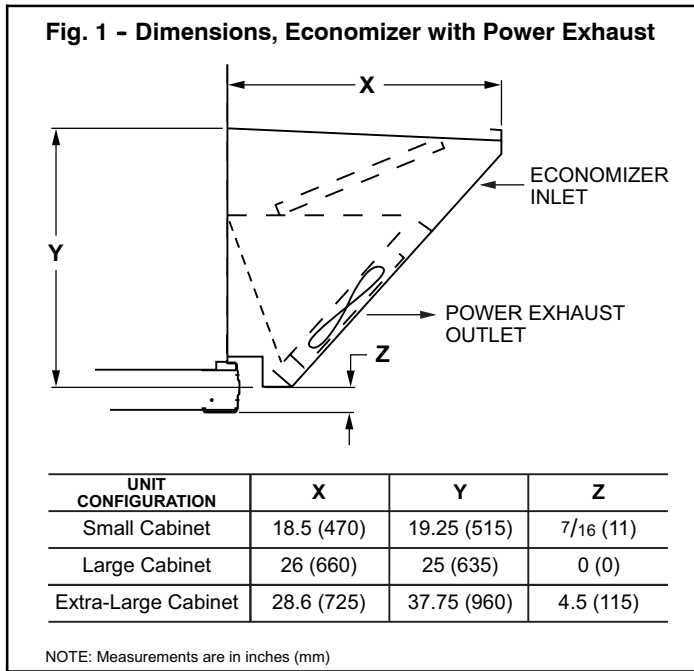

### INSTALLATION

**IMPORTANT:** Follow all applicable local and national electrical codes when installing this accessory.

Follow all local and NEC (National Electrical Code) codes. If a single power source is to be used, size the wire to include power exhaust MCA and MOCP. (See Table 2.)

**Table 2 – Power Exhaust Electrical Data**

POWER EXHAUST PART NO.	MCA (230 v)	MCA (460 v)	MCA (575 v)	MOCP (for separate power source)
DNPWREXH030A01	1.5	N/A	0.64	15
DNPWREXH021A01	N/A	0.9	N/A	15
DNPWREXH022A01 DNPWREXH080A00	3.3	N/A	1.32	15
DNPWREXH023A01 DNPWREXH081A00	N/A	1.8	N/A	15

**LEGEND**

- MCA – Minimum Circuit Amps
- MOCP – Maximum Overcurrent Protection
- N/A – Not Applicable

**NOTE:** For R-410A units, refer to unit nameplate for MCA and MOCP for installed power exhaust. For R-22 units, use the calculations detailed below.

Check MCA and MOCP when power exhaust is powered through the unit (must be in accordance with NEC and/or local codes). Determine the new MCA including the power exhaust using the following formula:

$$\text{MCA New} = \text{MCA unit only} + \text{MCA of Power Exhaust}$$

For example, using a R-22 gas heat, electric cooling, 6-ton unit with MCA = 28.9 and MOCP = 35, with DNPWREXH030A01 power exhaust.

$$\text{MCA New} = 28.9 \text{ amps} + 1.5 \text{ amps} = 30.4 \text{ amps}$$

If the new MCA does not exceed the published MOCP, then MOCP would not change. The MOCP in this example is 35 amps, the MCA New is below 35, therefore the MOCP is acceptable. If “MCA New” is larger than the published MOCP, raise the MOCP to the next larger size. For separate power, the MOCP for the power exhaust will be 15 amps per NEC.

**NOTE:** For 575-v installations, a field-supplied and installed transformer (FAST part no. 1171494) must be used with 208/230-v power exhaust. (See Fig. 6.)

The vertical power exhaust can be used with the following type of economizer

- Economizer with controller W7212.

**To install the vertical power exhaust, perform the following procedure:**

1. Turn off unit power supply and install lockout tag. For gas units, turn off the gas supply.

**⚠ WARNING**

**ELECTRICAL SHOCK HAZARD**

Failure to follow this warning could cause personal injury and/or death.

Before beginning any modification, be certain the main-line electrical disconnect switch is in the OFF position. Close the main gas supply shutoff valve. Tag disconnect switch and gas valve with suitable warning labels.

**NOTE:** Before installing, ensure voltage of power exhaust agrees with power supply to the equipment.

2. Remove the power exhaust knockout plugs located on the lower left side of the Economizer. (See Fig. 2.)

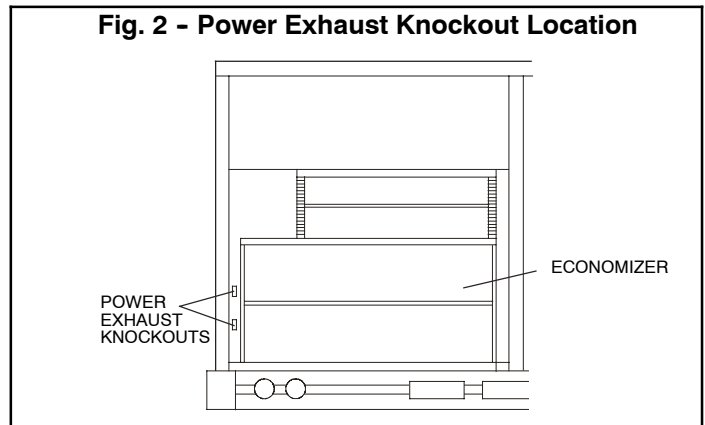

3. Remove the RTU unit filter panel to allow access to the inside of the rooftop.
4. The panel covering the horizontal return opening on the unit may also be removed for easier access and installation. Be sure to replace this panel when installation is complete.
5. Install the vertical economizer per the instructions provided with the economizer. Do not install the rainhood shipped with the Economizer. Set aside the aluminum air filter for use with the power exhaust.
6. Remove fan shield so power exhaust can lay flat without bending the shield or damaging the roof.
7. Remove the shipping blocks from the bottom of the accessory vertical power exhaust. (See Fig. 3.)

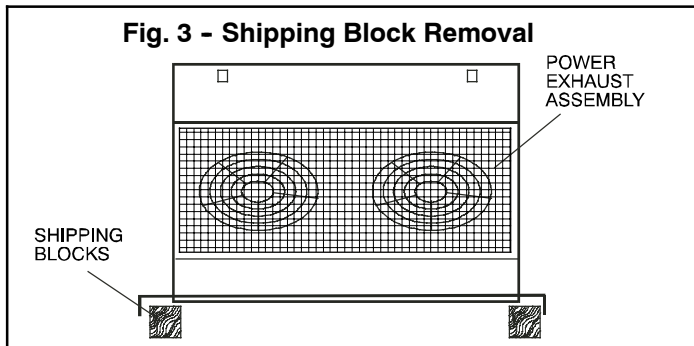

8. There may be a hinged door panel in place of the filter panel. Open the hinged door, remove the screws and hinges, remove the door and set it aside. Keep all screws and hinges.
9. Place the power exhaust close to the Economizer to allow for wiring harness connection.

**⚠ CAUTION**

**UNIT DAMAGE HAZARD**

Failure to follow this caution may result in equipment damage.

Be careful to route wires to avoid pinching or cutting during assembly. It can be difficult to protect the wires while attaching the power exhaust to the unit.

10. Follow the wiring instructions specific to the Economizer. Be sure power exhaust wiring does not interfere with damper operation.

### Power Exhaust Wiring with Economizer

Use these instructions and diagrams if using the vertical power exhaust with Economizer.

1. The 2-wire low voltage harness from the power exhaust and the 24 or 36 in (610 or 915 mm) low voltage extension harness are plugged together for shipping. Unplug these 2 harnesses for installation.
2. Insert the 2-wire low voltage harness plug from the power exhaust into the top knockout on the economizer. (See Fig. 2.)
3. From the rear of the economizer, connect the 24 or 36 in (610 or 915 mm) long low voltage extension harness plug to the power exhaust harness.
4. Route the other end of the low voltage extension harness to the economizer controller. (See Fig. 4.) The harness is connected to the controller by connecting the tan wire to the tan wire 24 VAC COM terminal on the controller. The terminal on the gray wire is connected to terminal EF1 on the controller. See Fig. 5 and 6 for economizer wiring diagrams. Install the gray jumper wire on the controller from the exhaust fan terminal (EF), to the 24 VAC HOT terminals. The gray jumper is shipped wire tied to the control harness.
5. The high voltage harness from the power exhaust and the high voltage extension harness are plugged together for shipping. Unplug these 2 harnesses for installation.
6. Insert the high voltage harness plug from the power exhaust into the bottom knockout on the economizer. (See Fig. 2 and 4.)

**R-410A Rooftop Models Only** — For single point wiring application, connect the power exhaust power wire harness to the compressor contactor or indoor fan contactor in the control box. Install the power exhaust power wire harness into the pressure lugs on the compressor contactor or indoor fan contactor, used for the field power wiring also.

Proceed to steps 7 and 8 for details on completing connection and routing.

7. From the rear of the economizer, connect the long high voltage extension harness plug to the power exhaust harness. (See Fig. 4.)
8. Route the other end of the long high voltage extension harness through the HVAC unit to the control box. (See Fig. 5.) The harness must be routed through the grommets provided in the unit. Do not drill routing holes. Be careful not to route the power exhaust harness on top of the indoor coil. Wire the end of the high voltage harness extension to the power exhaust power source. (See Fig. 6 and 7.)

**Fig. 4 - Power Exhaust Harness Installation for Economizer with W7212 Controller**

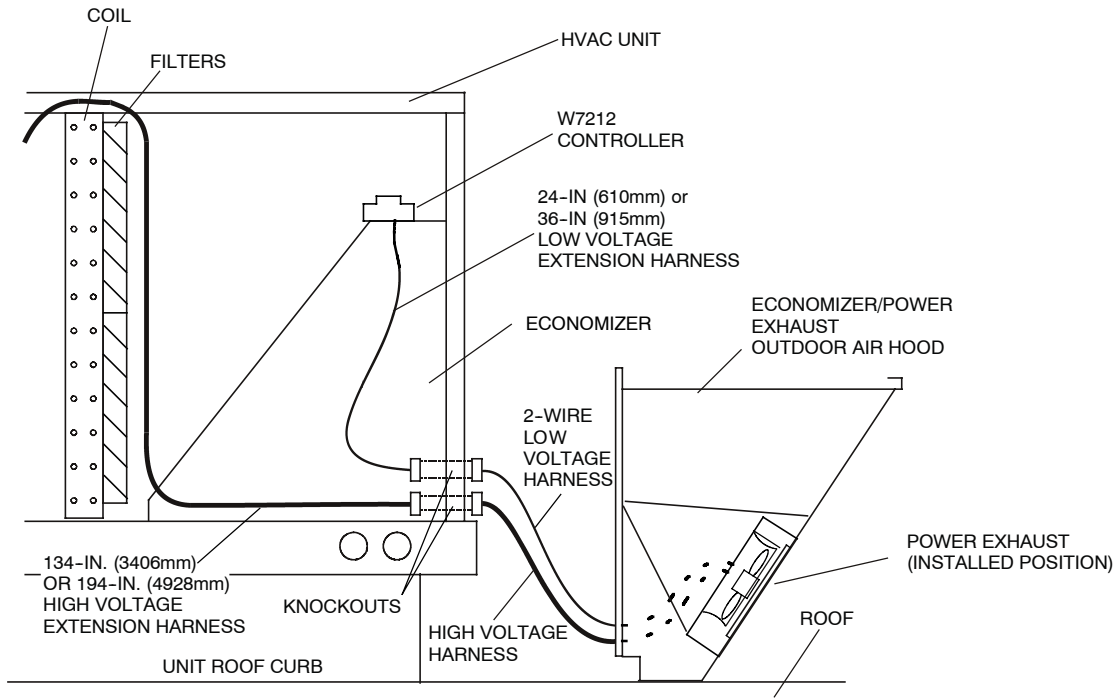

**Fig. 5 - Power Line Harness Routing (Top View of Unit Shown)**

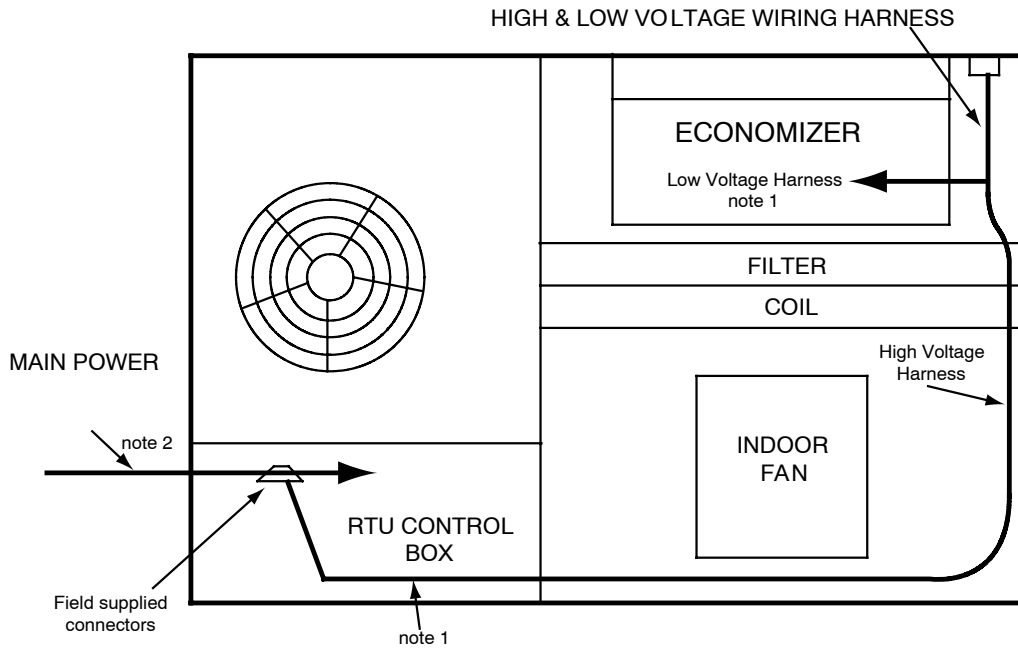

**Fig. 6 - Power Exhaust Wiring for Economizer with Controller W7212 — 208/230 V and 575 V Units**

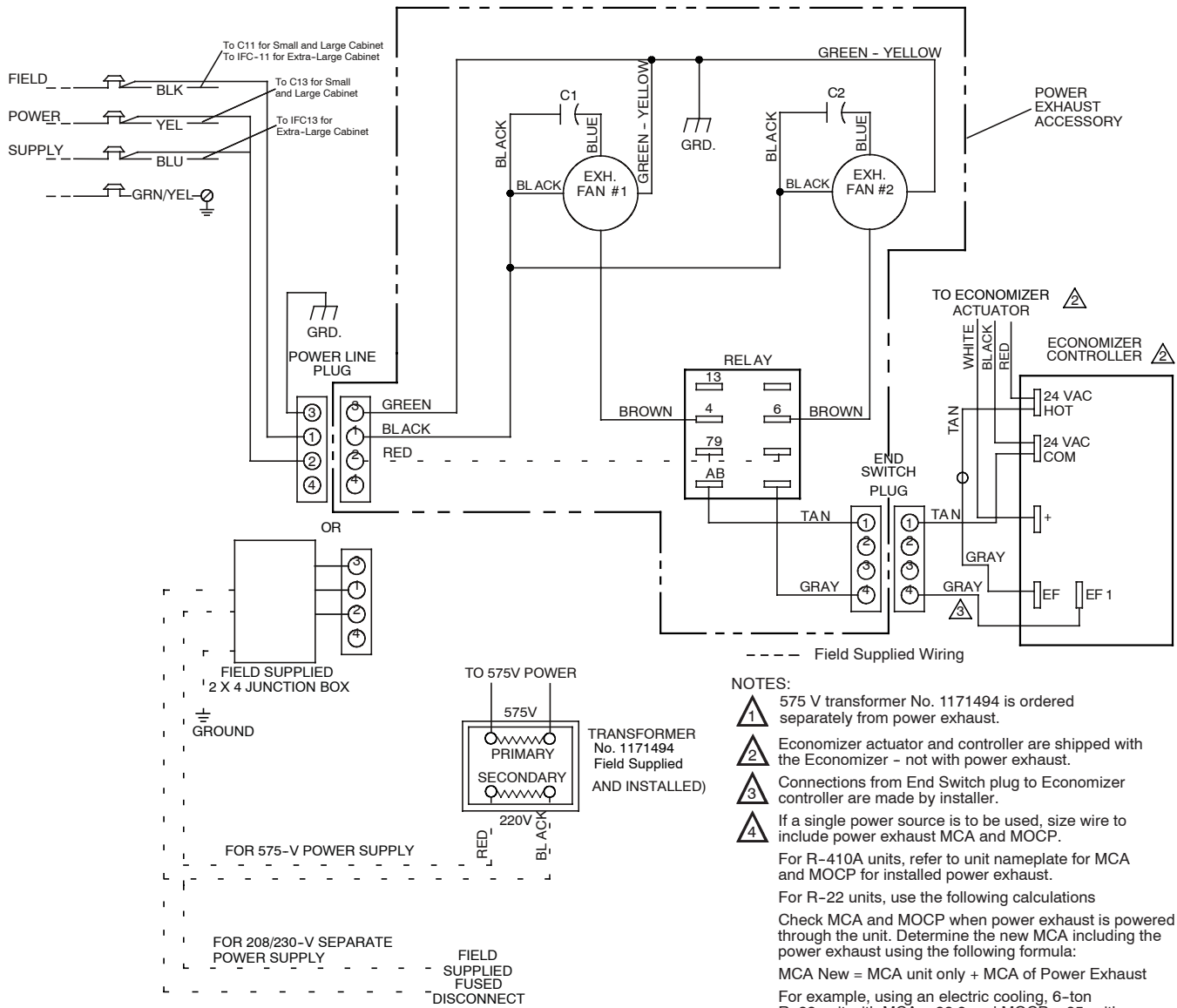

**Fig. 7 - Power Exhaust Cabinet Wiring for Economizer with Controller W7212 — 460 V Units**

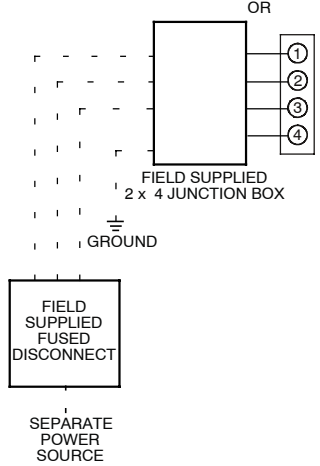
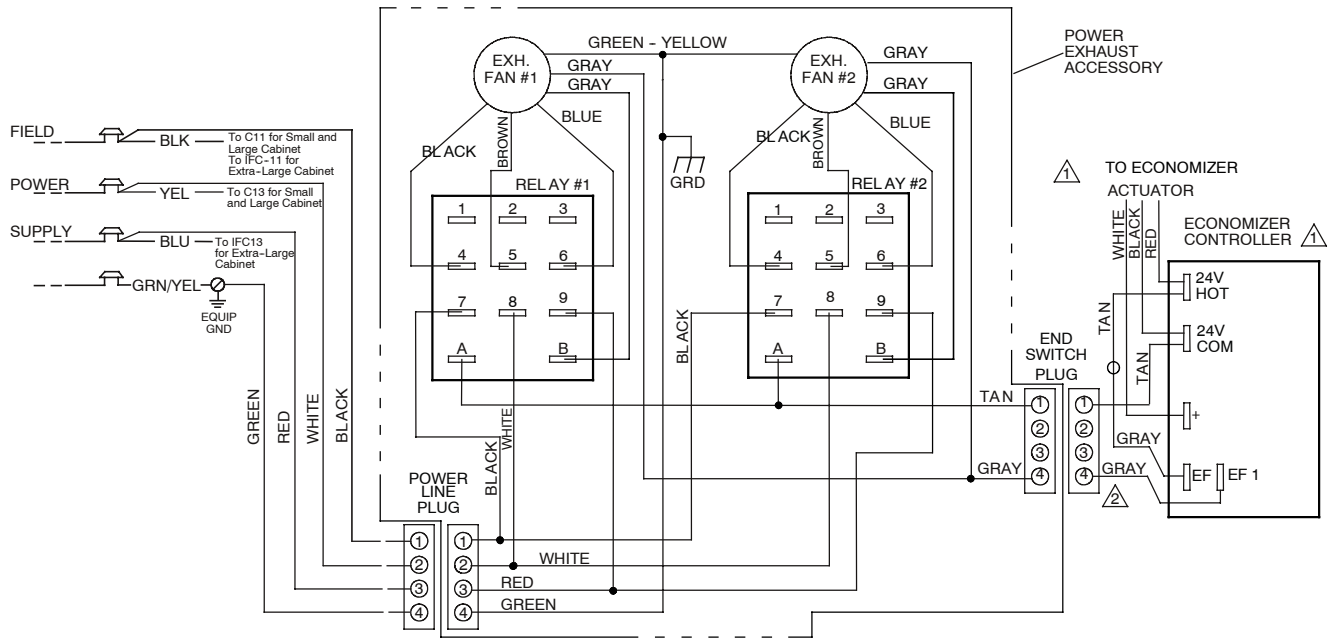

- Field Supplied Wiring
- NOTES:**
- ⚠ 1** Economizer actuator and controller are shipped with the Economizer not with power exhaust.
  - ⚠ 2** Connections from End Switch Plug to the Economizer controller are made by installer.
  - ⚠ 3** If a single power source is to be used, size wire to include power exhaust MCA and MOCP.
- For R-410A units, refer to the unit nameplate for MCA and MOCP for installed power exhaust.
- For R-22 units use the following calculations
- Check MCA and MOCP when power exhaust is powered through the unit. Determine the new MCA including the power exhaust using the following formula:
- MCA New = MCA unit only + MCA of Power Exhaust
- For example, using an electric cooling, 6-ton R-22 unit with MCA = 28.9 and MOCP = 35, with DNPWREXH030A01 power exhaust.
- MCA New = 28.9 amps + 1.5 amps = 30.4 amps
- If the new MCA does not go over the MOCP published, then MOCP would not change. The MOCP in this example is 35 amps, the MCA New is below 35, therefore the MOCP is OK. If "MCA NEW" is larger than the published MOCP, raise the MOCP to the next larger size. For separate power, the MOCP for the power exhaust will be 15 amps per NEC.

## Attaching Power Exhaust to the Unit

1. Make sure all power exhaust harnesses are connected as indicated in the previous steps. See Fig. 6 and 7 for Economizer.
2. Make sure all wiring is secure. Use field-supplied wire ties if necessary. Be sure that wiring does not interfere with operation of the HVAC unit, economizer, or power exhaust.
3. For units with a standard filter panel (i.e., no hinged door): Install the gasketing (provided) on the back of power exhaust side mating flanges. (See Fig. 8)

**NOTE:** This step does not apply to units with a hinged door.

**Fig. 8 - Gasketing Location Detail (Standard Filter Panel Only)**

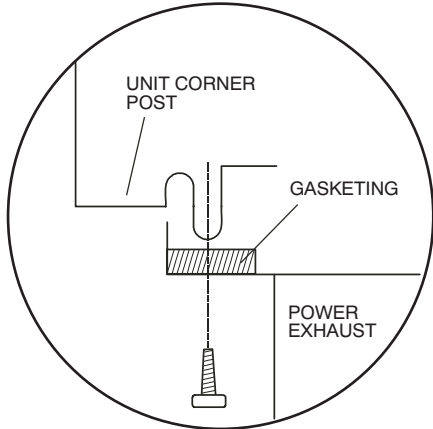

4. Lift power exhaust and install over economizer using the #10 x 3/4 in. long screws provided. Make sure wiring harnesses are properly secured. (See Fig. 9)

**Fig. 9 - Power Exhaust Installed on Unit**

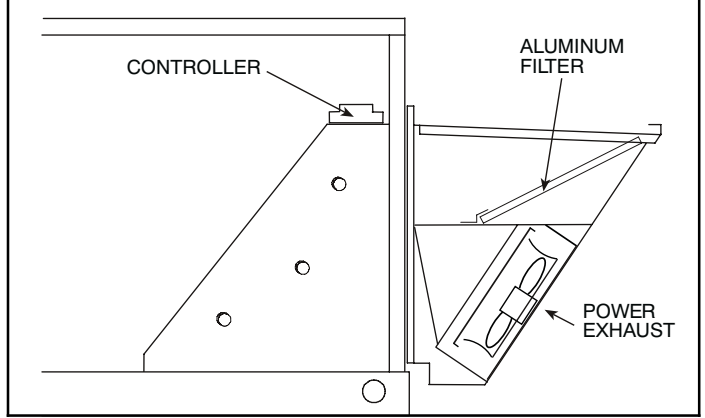

5. Locate the aluminum filter shipped with the economizer. (Extra-Large cabinet units have 2 filters.) Open the filter clips under the top hood of the power exhaust. Slide aluminum filter into the outside air opening of the power exhaust. Filter will slide past filter clips. Close filter clips, which will lock filter in place.
6. Reinstall the fan shield.
7. Return power to unit and remove lockout tag.
8. Test power exhaust operation by setting the power exhaust set point on the economizer controller to 0%. Power exhaust performance is shown in Fig. 10.
9. Adjust the power exhaust set point on the Economizer controller to the desired activation point per unit schematic.
10. For units with a standard filter access panel, reinstall the unit filter access door.

For units with a hinged access door (Small & Large Cabinet), install the hinged door seal angle included in the power exhaust kit using the instructions in this instruction. Do not proceed unless the sealing angle is installed. Units with a hinged door that do not have a sealing angle may not have a watertight seal.

**Fig. 10 - Power Exhaust Performance**

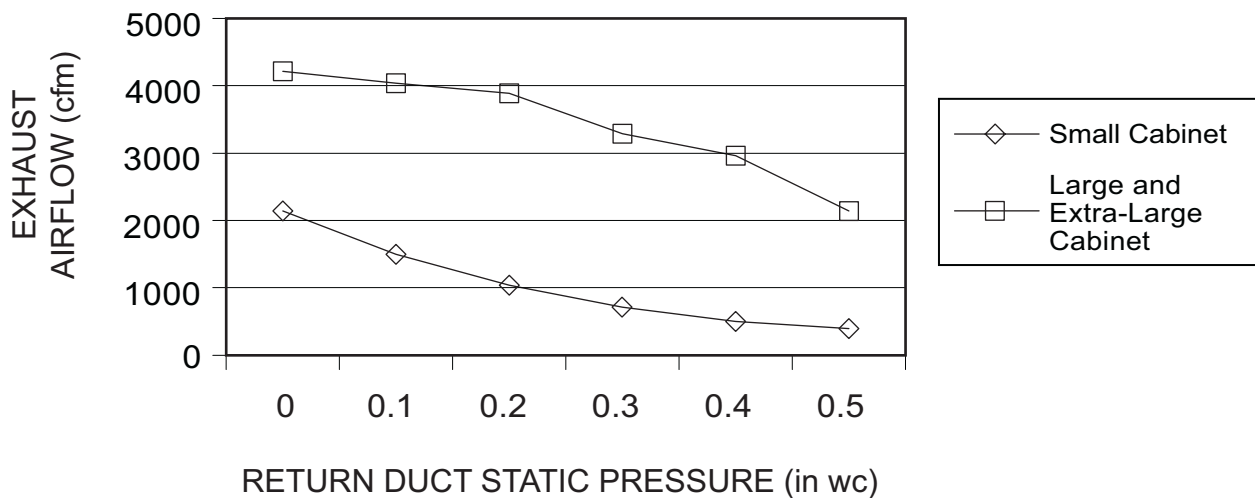

## Install the Hinged Door Angle (Small and Large Cabinet)

Follow these instructions if the unit has a hinged panel instead of a standard filter panel. Hinged Door Angle CRPECONV003A00 is for 3 to 6 ton units and CRPECONV004A00 is for 7<sup>1</sup>/<sub>2</sub> to 12<sup>1</sup>/<sub>2</sub> ton units.

1. Find the sealing angle and three screws provided in the power exhaust kit.
2. Attach the sealing angle to the top of the power exhaust hood using the screws provided. Refer to Fig. 14. Note that the gasketing flange will be facing out.
3. *If there are NO pre-drilled holes in the Power Exhaust hood:* Lay the hinged panel, insulation side up, on top of the hood so that the hinge screw holes align with the pre-drilled screw holes in the sealing angle. (For hoods with pre-drilled holes, skip to Step 7.)
4. Check the alignment of the hinged door with the side of the filter opening to be sure it will close properly.
5. Use a pencil to mark the hood where the screw holes will be.
6. Remove the hinged door and drill four (4) 1<sup>1</sup>/<sub>64</sub> in. holes where the marks are.

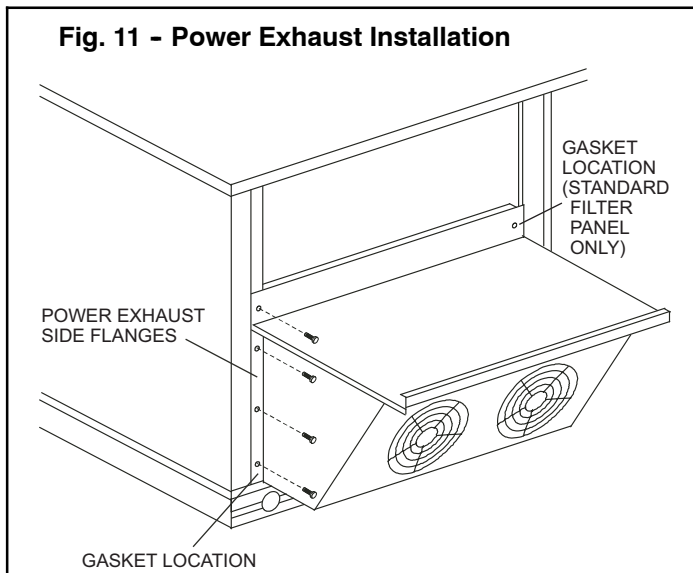

**NOTE:** The sealing angle will be in place; use the holes in it as a guide.

7. Place the door and hinges back on the unit. Screw through the door hinges and sealing angle into the flanged top of the hood using the 4 screws set aside when the hinged door was removed. (See Fig. 13.)
8. Close the hinged door and adjust handles if necessary.

