

COMMERCIAL STANDARD EFFICIENCY PACKAGE GAS/ELECTRIC UNIT R-22 SINGLE PACKAGE ROOFTOP 6 – 12.5 TONS (3-Phase)

REFRIGERATION CIRCUIT

- Scroll compressors on most models.
- High and low pressure switches and evaporator evaporator freeze thermostat.
- PGS090-150 have two stages of cooling, PGS072 is single stage.
- Anti-cycle timer built into the gas electronic control board.

BUILT TO LAST

- Tubular, dimpled heat exchangers.
- Pre-painted galvanized steel cabinet for long life and quality appearance.
- Integral commercial strength base rails. Holes provided for lifting lugs makes rooftop installation easier.
- Non-corrosive, sloped condensate drain pan, meets ASHRAE 62.

EASY TO INSTALL AND SERVICE

- Combination gas heating and electric cooling, self contained for year-round comfort. Systems installed on rooftop or ground level.
- Unit is shipped ready for downflow applications and can easily be converted to horizontal.
- Thru-the-bottom utility connection capability allow power, control wiring, and gas to be routed through unit base pan, minimizing roof penetrations.
- Exclusive integrated gas control board with diagnostics.
- Induced-draft fan for gas combustion.
- Direct-spark ignition systems.
- Factory wired to accept economizer.
- Refrigerant filter drier.

WARRANTY

- 10 year heat exchanger limited warranty
- 5 year compressor limited warranty
- 1 year parts limited warranty



PGS090-150 Shown



UNIT PERFORMANCE DATA

Model Number	COOLING			HEATING		Unit Dimensions H X W X L	Unit Weight
	Rated Capacity BTUH	E.E.R	IPLV	Input (MBTUH) Std. Stage 2 / Stage 1	Efficiency (Steady State) (AFUE) Std.		
PGS072*074A	72,000	9.0	n/a	- / 74,000	80	33-5/16" x 45" x 73-11/16"	565
PGS072*150A	72,000	9.0	n/a	150,000 / 120,000	80	33-5/16" x 45" x 73-11/16"	565
PGS090*125A	84,000	8.9	9.3	- / 125,000	80	41-5/16" x 57-3/4" x 87-3/8"	870
PGS090*224A	84,000	8.9	9.3	224,000 / 180,000	80	41-5/16" x 57-3/4" x 87-3/8"	870
PGS120*180A	115,000	8.9	9.3	180,000 / 120,000	80	49-15/16" x 57-3/4" x 87-3/8"	1035
PGS120*250A	115,000	8.9	9.3	250,000 / 200,000	80	49-15/16" x 57-3/4" x 87-3/8"	1035
PGS150*224A	142,000	8.8	9.1	224,000 / 180,000	80	49-15/16" x 57-3/4" x 87-3/8"	1050
PGS150*250A	142,000	8.8	9.1	250,000 / 200,000	80	49-15/16" x 57-3/4" x 87-3/8"	1050

* Unit voltage: H = 208/230v, L = 460v
NOTE: Low heat models available August 2008.

Table of Contents

	Page
Features/Benefits	1
Model Number Nomenclature	2
Unit Specifications	3-6
Dimensions	7-8
Performance Data	9-19
Typical Installation	20
Accessories	21-30
Controls	31
Guide Specs	31

MODEL NOMENCLATURE

MODEL SERIES	P	G	S	090	H	224	A
P = Package							
A = Air Conditioner							
H = Heat Pump							
G = Gas/Electric							
S = Standard Efficiency							
072 = 72,000							
090 = 90,000							
120 = 120,000							
150 = 150,000							
				NOMINAL COOLING BTU/h			
H = 208/230-3-60							
L = 460-3-60					VOLTAGE		
000 = N/A							
074 = 74,000							
125 = 125,000							
150 = 150,000							
180 = 180,000							
224 = 224,000							
250 = 250,000							
						NOMINAL HEATING BTU/h	
Sales Model Digit							

UNIT SPECIFICATIONS (Legend on 6 Page)		MODELS			
COOLING	PGS072H	PGS072L	PGS090H	PGS090L	
ARI Rated Capacity Btuh (Net)	72,000		84,000		
Nominal Tons	6		7-1/2		
Standard CFM	2100		2800		
EER	9.0		8.9		
IPLV	N/A		9.25		
Sound Rating (Bels)	8.1		8.7		
Unit Weight (lbs. / kg)	565 / 256		870 / 395		
ELECTRICAL	PGS072H	PGS072L	PGS090H	PGS090L	
Volts/ 3 Phase/ 60Hertz	208/230	460	208/230	460	
Voltage Range Min/Max	187 / 254	414 / 508	187 / 254	414 / 508	
Power Supply MCA	32.4 / 32.4	15.4	40.1 / 40.1	18.4	
Power Supply Circuit Breaker	40 / 40	20	45 / 45	25	
COMPRESSOR - QTY	SCROLL - 1		RECIPROCATING - 2		
Model	SR(Y,H)752AE*		CR42K6		
Oil (Oz.)	54		42 ea		
RLA / LRA	20.6 / 146.0	9.5 / 73.0	14.0 / 91.0	6.4 / 42.0	
REFRIGERANT TYPE	R-22				
Expansion Device	Fixed Orifice Metering Device		Fixed Orifice Metering Device		
Operating Charge....lb. oz....Circuit 1	9 - 0		4 - 13		
...Circuit 2	N/A		4 - 14		
CONDENSER FAN	Propeller Type				
Nominal CFM	4000		6400		
Quantity..Diameter (In.)	1...22		2...22		
Motor Hp...RPM	1/4...1100		1/4...1100		
Watts Input (Total)	325		600		
FLA	1.4	0.9	1.4	0.7	
CONDENSER COIL	Enhanced Copper Tubes, Aluminum Lanced fins				
Rows...Fin/In.	2...17		1...17		
Total Face Area (Sq. Ft.)	10.42		20.50		
EVAPORATOR COIL	Enhanced Copper Tubes, Aluminum Double Wavy Fins				
Rows...Fins/Inch	4...15		3...15		
Total Face Aea (sq. ft.)	5.5		8.0		
EVAPORATOR FAN	PGS072H,L	PGS090H,L			
	Centrifugal Type	Centrifugal Type			
Quantity...Size (in.)	1...10 x 10	1...15 x 15			
Type Drive	Belt	Belt			
Nominal CFM	2100	3000			
Max. Continuous Bhp	2.4	2.4			
FLA-208-230/460	5.2/2.6/2.6	5.8/2.6/2.6			
Motor Frame Size	56	56			
Fan RPM Range	1070-1460	590-840			
Motor Bearing	Ball	Ball			
Maximum Allowable RPM	2100	2100			
Motor Pulley Pitch / Diameter Min/Max. (in.)	2.8 / 3.8	2.4 / 3.4			
Motor Shaft Diameter (in.)	5/8	5/8			
Fan Pulley Pitch Diam (in)	4.5	7.0			
Belt, Quantitiy... Type... Length (in.)	1...A...40	1...A...49			
Pulley Center Line Distance (in)	14.7-15.5	16.75-19.25			
Speed Change per Full Turn of Movable Pulley Flange (RPM)	80	50			
Pulley Max. full Turns From Closed Postion	5	5			
Factory Setting	3	5			
Factory Speed Setting RPM	1225	590			
Fan Shaft Diam. at Pulley	5/8	1			

* Y = 208/230V, H = 460V

UNIT SPECIFICATIONS (Legend on 6 Page)		MODELS			
COOLING		PGS120H	PGS120L	PGS150H	PGS150L
ARI Rated Capacity Btuh (Net)		115,000		142,000	
Nominal Tons		10		12-1/2	
Standard CFM		4000		4500	
EER		8.9		8.8	
IPLV		9.25		9.1	
Sound Rating (Bels)		8.8		8.7	
Unit Weight (lbs. / kg)		1035 / 469		1050 / 476	
ELECTRICAL		PGS120H	PGS120L	PGS150H	PGS150L
Volts		208/230-3-60	460-3-60	208/230-3-60	460-3-60
Voltage Range Min/Max		187 / 254	414 / 508	187 / 254	414 / 508
Power Supply MCA		44.2 / 44.2	21.8	65.2 / 65.2	29.6
Power Supply MOCP*		50 / 50	25	80 / 80 **	40
COMPRESSOR - QTY		RECIPROCATING - 2		SCROLL - 2	
Model		GB20K		SR(Y,H)752AE *	
Oil (Oz.)		54 ea		54 ea	
RLA / LRA		15.8 / 130	7.9 / 64.0	23 / 146.0	10.4 / 73.0
REFRIGERANT TYPE		R-22			
Expansion Device		Fixed Orifice Metering Device			
Operating Charge....lb. oz....Circuit 1		7 - 3		8 - 10	
...Circuit 2		7 - 13		8 - 6	
CONDENSER FAN		Propeller Type			
Nominal CFM		7000		7000	
Quantity..Diameter (In.)		2...22		2...22	
Motor Hp...RPM		1/4...1100		1/4...1100	
Watts Input (Total)		600		600	
FLA		1.4	0.7	1.4	0.7
CONDENSER COIL		Enhanced Copper Tubes, Aluminum Lanced fins			
Rows...Fin/In.		2...17		2...17	
Total Face Area (Sq. Ft.)		20.47		25.0	
EVAPORATOR COIL		Enhanced Copper Tubes, Aluminum Double Wavy Fins			
Rows...Fins/Inch		3...15		4...15	
Total Face Aea (sq. ft.)		10.0		11.1	
EVAPORATOR FAN		Centrifugal Type			
Quantity...Size (in.)		1...15 x 15		1...15 x 15	
Type Drive		Belt		Belt	
Nominal CFM		4000		5000	
Max. Continuous Bhp		2.4		5.25	
FLA-208-230/460		5.8/2.6/2.6		15.0/7.4/7.4	
Motor Frame Size		56		56	
Fan RPM Range		685-935		900-1260	
Motor Bearing		Ball		Ball	
Maximum Allowable RPM		2100		2100	
Motor Pulley Pitch / Diameter Min/Max. (in.)		2.8 / 3.8		3.1 / 4.1	
Motor Shaft Diameter (in.)		5/8		7/8	
Fan Pulley Pitch Diam (in)		7.0		5.9	
Belt, Quantity...Type... Length (in.)		1...A...49		1...BX...46	
Pulley Center Line Distance (in)		15.85-17.50		15.85-17.50	
Speed Change per Full Turn of Movable Pulley Flange (RPM)		50		44	
Pulley Max. full Turns From Closed Postion		5		5	
Factory Setting		5		6	
Factory Speed Setting RPM		685		960	
Fan Shaft Diam. at Pulley		1		1	

UNIT SPECIFICATIONS (CONT)		MODELS			
FURNACE SECTION		PGS072	PGS090	PGS120	PGS150
Rollout Switch Cutout Temp (F)		195	195	195	195
Burner Orifice Diameter (in. ...drill size)		074 / 150	125 / 224	180 / 250	224 / 250
BTUH (x1,000)					
Natural Gas		.113...33 / .129...30	.120...31 / .120...31	.120...31 / .129...30	.120...31 / .129...30
Liquid Propane		.089...43 / .104...37	.096...41 / .096...41	.094...41 / .102...38	.096...41 / .102...38
Thermostat Heat Anticipator Setting (amps)					
208/230 v	Stage 1	14	14	14	14
208/230 v	Stage 2	14	20	20	20
460 v	Stage 1	14	14	14	14
460 v	Stage 2	14	20	20	20
Gas Input (Btuh)					
Stage 2 / Stage 1		- / 74,000	- / 125,000	180,000 / 120,000	224,000 / 180,000
Output Capacity (Btuh)		59,200	100,000	144,000	179,200
Stage 2 / Stage 1		150,000 / 120,000	224,000 / 180,000	250,000 / 200,000	250,000 / 200,000
Output Capacity (Btuh)		120,000	179,200	200,000	200,000
Efficiency (Steady State) (%) AFUE		80	80	80	80
Temperature Rise Range BTUH (x1,000)		074 / 150	125 / 224	180 / 250	224 / 250
Range		25-55 / 50-80	20-50 / 45-75	35-65 / 40-70	35-65 / 40-70
Manifold Pressure (in. wg)					
Natural Gas		3.5	3.5	3.5	3.5
Liquid Propane		3.5	3.5	3.5	3.5
Gas Valve Quantity		1	1	1	1
Gas Valve Pressure Range Psig		0.180-0.487	0.180-0.487	0.180-0.487	0.180-0.487
in. wg		5.0-13.5	5.0-13.5	5.0-13.5	5.0-13.5
Field Gas Connection Size (in.)		1/2	3/4	3/4	3/4
HIGH-PRESSURE SWITCH (psig)					
Standard Compressor		450 +/- 50	450 +/- 50	450 +/- 50	500 +/- 50
Internal Relief (Differential) Cutout		428	428	428	428
Reset (Auto.)		320	320	320	320
LOSS-OF-CHARGE SWITCH (psig) (LOW-PRESS.)					
Cutout		7 +/- 3	7 +/- 3	7 +/- 3	7 +/- 3
Reset (Auto.)		22 +/- 7	22 +/- 7	22 +/- 7	22 +/- 7
FREEZE PROTECTION THERMOSTAT (°F)					
Opens		30 +/- 5	30 +/- 5	30 +/- 5	30 +/- 5
Closes		45 +/- 5	45 +/- 5	45 +/- 5	45 +/- 5
RETURN-AIR FILTERS (THROWAWAY)					
Quantity...Size (in.)		2...16 x 25 x 2	4...16 x 20 x 2	4...20 x 20 x 2	4...20 x 20 x 2

LEGENDS AND NOTES

Bhp = Brake Horsepower

Legend

Bels	-	Sound Levels
EER	-	Energy Efficiency Ratio
IPLV	-	Integrated Part Load Values
MCA	-	Minimum Circuit Amps
MOCP	-	Maximum Over-current Protection
FLA	-	Full Load Amps
LRA	-	Locked Rotor Amps
*	-	Fuse or HACR circuit breaker
RLA	-	Rated Load Amps

NOTES: 1. Rated in accordance with ARI Standards 210/240, latest revision (for sizes 090 & 120) or 360, latest revision (for size 150).

2. ARI ratings are net values, reflecting the effects of circulating fan heat.

3. Ratings are based on:

Cooling Standard: 80F db, 67F wb indoor entering air temperature and 95F db air entering outdoor unit.

IPLV Standard: 80F db, 67F wb indoor entering air temperature and 80F db entering air temperature.

EXAMPLE: Supply voltage is 460-3-60.

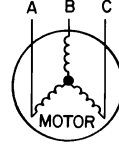

$$\begin{aligned}
 AB &= 452 \text{ v} & \text{Average Voltage} &= \frac{452 + 464 + 455}{3} \\
 BC &= 464 \text{ v} & &= \frac{1371}{3} \\
 AC &= 455 \text{ v} & &= 457
 \end{aligned}$$

Determine maximum deviation from average voltage.

$$(AB) 457 - 452 = 5 \text{ V}$$

$$(BC) 464 - 457 = 7 \text{ V}$$

$$(AC) 457 - 455 = 2 \text{ V}$$

Maximum deviation is 7 v.

Determine percent voltage imbalance.

$$\% \text{ Voltage Imbalance} = 100 \times \frac{7}{457} = 1.53\%$$

This amount of phase imbalance is satisfactory as it is below the maximum allowable 2%.

IMPORTANT: If the supply voltage phase imbalance is more than 2%, contact your local electric utility company immediately.

NOTES:

1. In compliance with NEC requirements for multimotor and combination load equipment (refer to NEC Articles 430 and 440), the over-current protective device for the unit shall be fuse or HACR breaker. Canadian units may be fuse or circuit breaker.

2. Unbalanced 3-Phase Supply Voltage

Never operate a motor where a phase imbalance in supply voltage is greater than 2%. Use the following formula to determine the percent voltage imbalance.

% Voltage Imbalance

$$= 100 \times \frac{\text{max voltage deviation from average voltage}}{\text{average voltage}}$$

BASE UNIT WEIGHT AND DIMENSIONS - PGS072

Unit	Total Weight		Corner A		Corner B		Corner C		Corner D		Dim K	
	lb	kg	lb	kg	lb	kg	lb	kg	lb	kg	inches	mm
PGS072	565	256	165	75	136	62	200	91	64	29	12-3/8	315

All measurements in inches (mm)

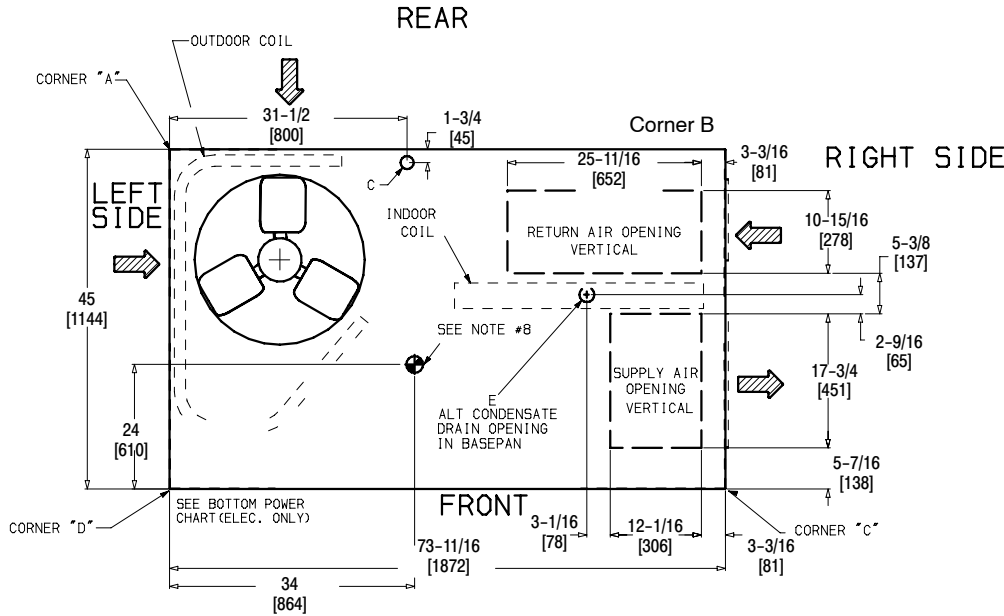

THREADED CONDUIT SIZE	WIRE USE	REQUIRED HOLE SIZES (MAX.)
1/2"	ACC	7/8" [22]
1/2"	24	7/8" [22]
3/4"	Power*	1-1/8" [28.4]
1-1/4" FPT	Power*	1-3/4" [44.4]
1/2" FPT	GAS	1-1/4" [31.8]
3/4" FPT	GAS	1-5/8" [41.3]

* Select either 3/4" or 1-1/4" for power, depending on wire size.

Connection Sizes - PGS072	
A	1-3/8" Dia (35) Field Power Supply Hole
B	2" Dia (51) Power Supply Knockout
C	2-1/2" Dia (44) Charging Port Hole
D	7/8" Dia (22) Field Control Wiring Hole
E	3/4"-14 NPT Condensate Drain
F	1/2"-14 NPT Gas Connection

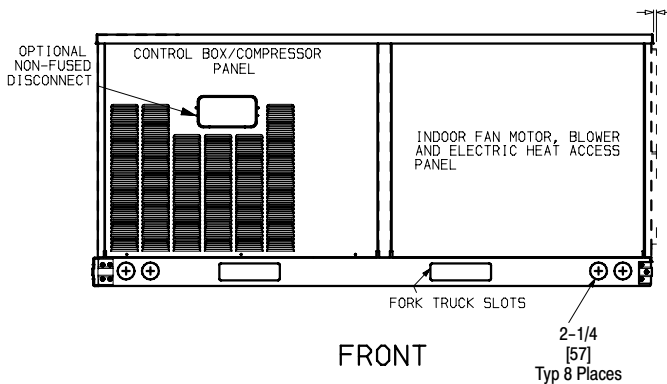
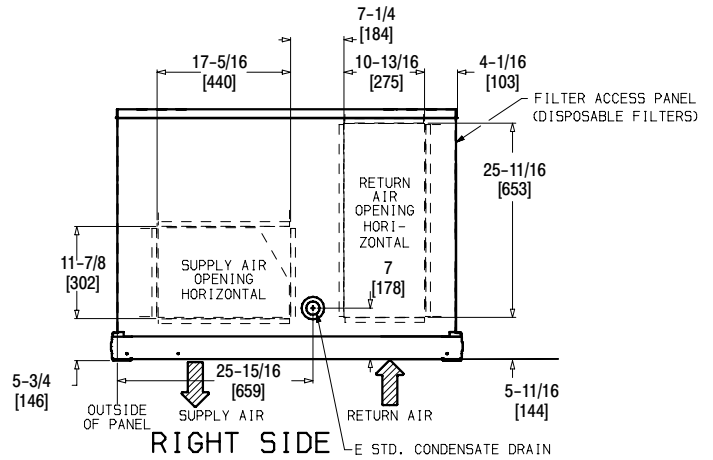
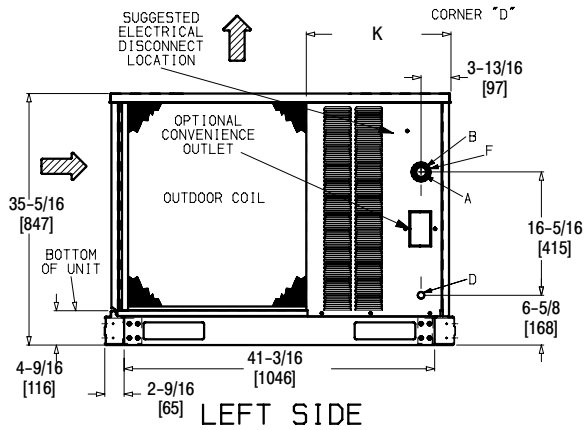

BASE UNIT DIMENSIONS PGS090-150

Unit	Total		Corner A		Corner B		Corner C		Corner D		Dim A		Dim B		Dim C	
	lb	kg	lb	kg	lb	kg	lb	kg	lb	kg	inches	mm	inches	mm	inches	mm
PGS090	870	395	189	86	161	73	239	109	280	127	14 ⁷ / ₈	378	41 ⁵ / ₁₆	1050	33 ¹¹ / ₁₆	856
PGS120	1035	489	225	102	192	87	285	129	333	151	29 ⁷ / ₈	759	49 ¹⁵ / ₁₆	1253	3- ³ / ₈	924
PGS150	1050	476	228	103	195	88	289	131	338	153	14 ⁷ / ₈	378	49 ¹⁵ / ₁₆	1253	3- ³ / ₈	924

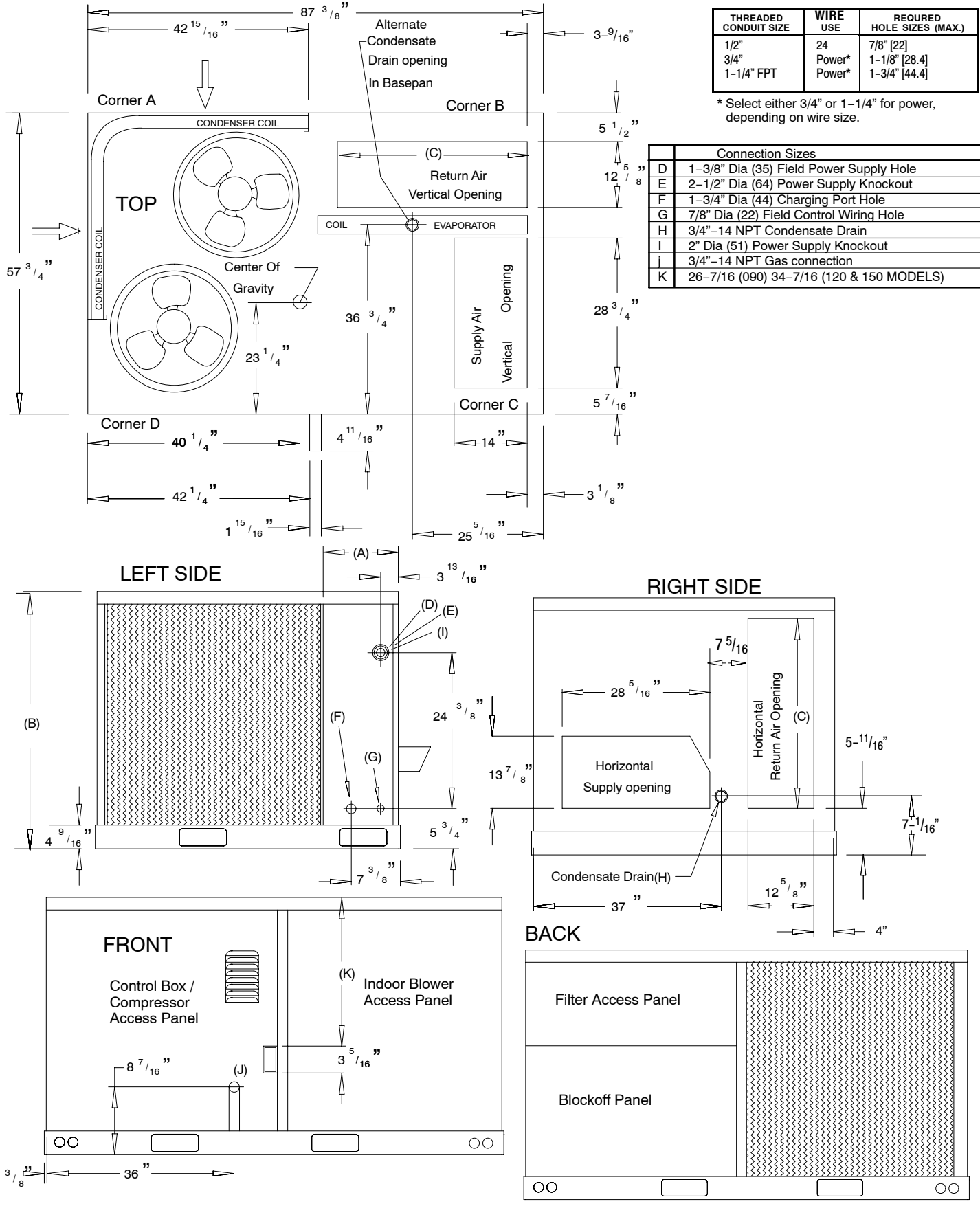

EXPANDED PERFORMANCE DATA (COOLING) 6 TON – GROSS DATA

Temp (F) Air Entering Condenser (Edb)		Air Entering Evaporator — Cfm/BF											
		1800/0.06			2100/0.08			2400/0.09			3000/0.11		
		Air Entering Evaporator — Ewb (F)											
		72	67	62	72	67	62	72	67	62	72	67	62
75	TC	86.6	80.0	73.6	87.8	80.3	73.2	90.8	84.1	77.2	93.2	86.6	79.7
	SHC	42.2	52.3	62.2	43.0	53.9	65.5	46.5	59.6	71.6	50.1	66.4	78.7
	KW	5.48	5.33	5.21	5.69	5.50	5.32	5.59	5.44	5.29	5.66	5.51	5.35
85	TC	84.1	77.4	71.0	84.0	77.2	69.5	87.8	81.2	74.5	90.1	83.5	77.3
	SHC	41.4	51.3	61.1	41.7	53.1	64.0	45.5	58.6	70.3	49.4	65.4	76.7
	KW	6.17	6.00	5.85	6.21	6.04	5.83	6.27	6.11	5.94	6.35	6.19	6.02
95	TC	81.6	74.7	68.5	81.0	73.5	66.3	84.8	78.2	71.8	87.0	80.4	74.8
	SHC	40.6	50.3	60.0	40.8	51.8	62.8	44.6	57.6	69.1	48.7	64.5	74.7
	KW	6.86	6.67	6.49	6.78	6.54	6.33	6.95	6.77	6.59	7.03	6.86	6.69
105	TC SHC	78.4	71.8	65.6	76.8	69.7	62.5	81.6	74.9	68.9	83.3	76.9	72.1
	KW	39.4	49.2	58.7	39.4	50.3	61.1	43.5	56.4	67.4	47.4	63.1	72.0
		7.60	7.39	7.20	7.30	7.05	6.80	7.72	7.50	7.31	7.77	7.59	7.41
115	TC SHC	75.1	68.7	62.5	72.5	65.5	58.75	78.0	71.5	66.1	79.5	73.3	69.3
	KW	38.1	47.9	57.2	37.9	48.7	8.7	42.3	55.1	65.5	46.3	61.6	69.2
		8.36	8.14	7.93	7.81	7.53	7.27	8.49	8.25	8.06	8.55	8.33	8.18

FORMULAS AND NOTES FOR USING EXPANDED PERFORMANCE DATA

To find leaving wet bulb and dry bulb from the expanded performance charts, use the following formulas.

1. Direct interpolation is permissible. Do not extrapolate.
2. The following formulas may be used:
 $t/db = t\ edb - \text{sensible capacity Btuh} / (1.10 \times \text{cfm})$
 $t/wb = \text{Wet bulb temp. corresponding to enthalpy of air leaving evaporator coil (h/wb)}$
 $h/wb = h\ ewb - \text{total capacity Btuh} / (4.5 \times \text{cfm})$
 where h ewb = Enthalpy of air entering evap. coil
3. The SHC is based on 80F edb of air entering evap coil. Below 80F edb, subtract (corr factor x cfm) from SHC. Above 80F edb, add (corr factor x cfm) to SHC.

LEGEND

MBH = Total Capacity (Gross)
 S/T = Sensible to Total Ratio
 KW = Compressor Motor Power Input.
 IDB = Indoor DryBulb
 edb = Entering DryBulb
 ewb = Entering Wet Bulb
 t/db = Leaving DryBulb
 t/wb = Leaving Wet Bulb
 h/wb = Enthalpy of Leaving Wet Bulb
 SHC = Sensible Heat Capacity
 BF = Bypass Factor

BYPASS FACTOR (BF)	ENTERING AIR DRY BULB					
	79	78	77	76	75	under 75
	81	82	83	84	85	over 85
	Correction Factor					
.05	1.04	2.07	3.11	4.14	5.18	Use formulas shown below
.10	0.98	1.96	2.94	3.92	4.90	
.20	0.87	1.74	2.62	3.49	4.36	
.30	0.76	1.53	2.29	3.05	3.82	

Correction Factor = 1.10 x (1-BF) x (edb-80).

EXPANDED PERFORMANCE DATA (COOLING) 7-1/2 TON – GROSS DATA

Temp (F) Air Entering Condenser (Edb)		Air Entering Evaporator — Cfm/BF											
		2250/0.10			2800/0.11			3000/0.11			3750/0.14		
		Air Entering Evaporator — Ewb (F)											
		72	67	62	72	67	62	72	67	62	72	67	62
75	TC	105.8	97.6	88.7	108.9	101.1	92.6	109.5	101.9	93.5	112.4	104.6	96.4
	SHC	50.9	63.6	75.4	54.1	69.8	84.0	55.2	71.9	86.5	59.9	79.7	94.9
	KW	6.34	6.05	5.77	6.46	6.19	5.93	6.50	6.25	5.96	6.62	6.37	6.09
85	TC	101.1	92.9	84.0	104.8	96.4	87.7	105.6	97.2	88.5	107.7	99.6	92.2
	SHC	49.4	62.0	73.3	53.1	68.4	81.9	54.4	70.6	84.4	58.5	78.2	92.0
	KW	6.80	6.51	6.21	6.94	6.66	6.37	6.98	6.69	6.41	7.08	6.82	6.57
95	TC	96.6	87.7	78.9	99.9	91.0	82.4	100.5	91.6	83.6	102.3	93.9	87.7
	SHC	47.8	59.9	70.8	51.7	66.5	79.5	52.9	68.8	81.3	57.2	76.6	87.7
	KW	7.26	6.96	6.64	7.42	7.10	6.78	7.46	7.14	6.83	7.54	7.24	7.03
105	TC	91.0	82.1	72.96	93.7	85.2	76.8	94.3	85.9	78.2	96.6	87.9	83.0
	SHC	45.9	57.9	7.9	49.6	64.4	76.4	50.9	66.7	77.8	55.8	74.5	83.0
	KW	7.70	7.37	7.08	7.81	7.51	7.22	7.86	7.54	7.28	7.97	7.67	7.47
115	TC	85.2	76.0	67.9	47.8	62.2	71.6	88.1	79.7	73.1	90.2	81.7	78.2
	SHC	43.9	55.4	65.1	8.25	7.92	71.6	49.2	64.4	73.1	54.4	72.5	78.0
	KW	8.13	7.79	7.47	87.7	79.1	7.67	8.29	7.95	7.74	8.41	8.08	7.93

FORMULAS AND NOTES FOR USING EXPANDED PERFORMANCE DATA

To find leaving wet bulb and dry bulb from the expanded performance charts, use the following formulas.

1. Direct interpolation is permissible. Do not extrapolate.
2. The following formulas may be used:
 $t/db = t\ edb - \text{sensible capacity Btuh} / (1.10 \times \text{cfm})$
 $t/wb = \text{Wet bulb temp. corresponding to enthalpy of air leaving evaporator coil (h/wb)}$
 $h/wb = h\ ewb - \text{total capacity Btuh} / (4.5 \times \text{cfm})$
 where h ewb = Enthalpy of air entering evap. coil
3. The SHC is based on 80F edb of air entering evap coil. Below 80F edb, subtract (corr factor x cfm) from SHC. Above 80F edb, add (corr factor x cfm) to SHC.

LEGEND

MBH = Total Capacity (Gross)
 S/T = Sensible to Total Ratio
 KW = Compressor Motor Power Input.
 IDB = Indoor Dry Bulb
 edb = Entering Dry Bulb
 ewb = Entering Wet Bulb
 t/db = Leaving Dry Bulb
 t/wb = Leaving Wet Bulb
 h/wb = Enthalpy of Leaving Wet Bulb
 SHC = Sensible Heat Capacity

BYPASS FACTOR (BF)	ENTERING AIR DRY BULB					
	79	78	77	76	75	under 75
	81	82	83	84	85	over 85
Correction Factor						
.05	1.04	2.07	3.11	4.14	5.18	Use formulas shown below
.10	0.98	1.96	2.94	3.92	4.90	
.20	0.87	1.74	2.62	3.49	4.36	
.30	0.76	1.53	2.29	3.05	3.82	

Correction Factor = 1.10 x (1-BF) x (edb-80).

EXPANDED PERFORMANCE (COOLING) 10 TON (GROSS CAPACITY)

Temp (F) Air Entering Condenser (Edb)		Air Entering Evaporator — Cfm/BF								
		3000/0.095			4000/0.125			5000/0.15		
		Air Entering Evaporator — Ewb (F)								
		72	67	62	72	67	62	72	67	62
75	TC	135.8	124.8	112.0	142.4	130.6	119.8	146.5	134.2	123.7
	SHC	66.8	82.6	97.4	73.2	93.4	112.7	79.7	104.4	123.1
	kW	9.76	9.41	9.10	10.00	9.61	9.27	10.17	9.75	9.41
85	TC	130.0	119.6	104.0	136.0	125.0	114.5	140.0	127.9	118.8
	SHC	64.3	80.5	93.8	71.1	91.7	110.2	77.5	101.8	118.7
	kW	10.41	10.07	9.74	10.67	10.28	9.94	10.84	10.41	10.09
95	TC	124.1	113.7	96.7	129.5	118.9	106.9	132.8	122.0	114.1
	SHC	62.2	78.4	90.0	69.1	89.8	105.9	74.9	100.1	114.0
	kW	11.13	10.78	10.40	11.38	10.99	10.63	11.52	11.14	10.83
105	TC	118.1	104.6	87.9	122.7	111.8	98.5	126.0	115.1	108.0
	SHC	60.4	74.9	85.2	66.9	87.7	98.5	73.1	98.3	108.0
	kW	11.93	11.52	11.10	12.13	11.74	11.41	12.27	11.89	11.65
115	TC	115.0	98.0	84.2	120.0	103.8	93.4	122.6	109.8	102.8
	SHC	59.4	72.4	83.4	66.4	84.8	93.4	72.8	96.9	102.8
	kW	12.26	11.82	11.40	12.48	12.06	11.78	12.60	12.20	12.00

FORMULAS AND NOTES FOR USING EXPANDED PERFORMANCE DATA

To find leaving wet bulb and drybulb from the expanded performance charts, use the following formulas.

1. Direct interpolation is permissible. Do not extrapolate.

2. The following formulas may be used:

$$t/db = t edb - \text{sensible capacity Btuh} / (1.10 \times \text{cfm})$$

$$t/wb = \text{Wet bulb temp. corresponding to enthalpy of air leaving evaporator coil (h/wb)}$$

$$h/wb = h ewb - \text{total capacity Btuh} / (4.5 \times \text{cfm})$$

where h ewb = Enthalpy of air entering evap. coil

3. The SHC is based on 80F edb of air entering evap coil. Below 80F edb, subtract (corr factor x cfm) from SHC. Above 80F edb, add (corr factor x cfm) to SHC.

LEGEND	
MBH	= Total Capacity (Gross)
S/T	= Sensible to Total Ratio
KW	= Compressor Motor Power Input.
IDB	= Indoor Dry Bulb
edb	= Entering Dry Bulb
ewb	= Entering Wet Bulb
t/db	= Leaving Dry Bulb
t/wb	= Leaving Wet Bulb
h/wb	= Enthalpy of Leaving Wet Bulb
SHC	= Sensible Heat Capacity

BYPASS FACTOR (BF)	ENTERING AIR DRY BULB						Use formulas shown below
	79	78	77	76	75	under 75	
	81	82	83	84	85	over 85	
	Correction Factor						
.05	1.04	2.07	3.11	4.14	5.18		
.10	0.98	1.96	2.94	3.92	4.90		
.20	0.87	1.74	2.62	3.49	4.36		
.30	0.76	1.53	2.29	3.05	3.82		

$$\text{Correction Factor} = 1.10 \times (1 - \text{BF}) \times (\text{edb} - 80).$$

EXPANDED PERFORMANCE DATA (COOLING) 12-1/2 TON – GROSS DATA

Temp (F) Air Entering Condenser (Edb)		Air Entering Evaporator — Cfm/BF											
		3750/0.08			4500/0.09			5000/0.10			6250/0.12		
		Air Entering Evaporator — Ewb (F)											
		72	67	62	72	67	62	72	67	62	72	67	62
75	TC	175.6	162.2	149.2	181.0	167.5	154.2	182.9	170.2	156.4	187.2	174.7	161.8
	SHC	85.7	107.3	128.0	91.4	116.2	140.3	94.2	122.2	146.5	102.1	135.3	160.7
	KW	11.16	10.85	10.57	11.32	11.00	10.69	11.37	11.07	10.73	11.49	11.19	10.87
85	TC	169.3	155.7	140.6	174.2	160.7	147.0	176.9	163.0	149.7	181.5	167.3	155.8
	SHC	83.9	104.8	124.0	89.6	113.9	137.0	92.7	119.7	143.6	100.9	133.4	155.6
	KW	12.15	11.78	11.42	12.31	11.94	11.58	12.39	12.01	11.63	12.53	12.14	11.82
95	TC	161.9	148.9	132.0	166.8	153.5	139.1	169.5	155.7	142.8	173.2	159.5	149.6
	SHC	81.4	102.0	119.8	87.0	111.1	133.2	90.7	117.3	140.2	98.3	130.8	149.6
	KW	13.12	12.72	12.28	13.30	12.89	12.46	13.40	12.97	12.56	13.54	13.11	12.78
105	TC	154.9	141.3	123.0	158.8	145.4	130.2	160.9	147.6	135.0	165.3	151.2	143.2
	SHC	79.0	99.2	115.5	84.5	108.2	128.1	87.8	114.3	134.9	96.6	127.8	143.1
	KW	14.16	13.66	13.17	14.31	13.82	13.35	14.38	13.91	13.48	14.58	14.07	13.77
115	TC	146.2	132.2	113.1	150.5	137.0	122.4	152.3	139.4	127.8	155.2	142.7	136.0
	SHC	76.1	95.7	110.3	81.7	105.2	122.3	85.0	111.6	127.7	92.9	125.0	135.8
	KW	15.09	14.57	14.07	15.30	14.76	14.25	15.37	14.87	14.43	15.49	15.02	14.73

FORMULAS AND NOTES FOR USING EXPANDED PERFORMANCE DATA

To find leaving wet bulb and drybulb from the expanded performance charts, use the following formulas.

1. Direct interpolation is permissible. Do not extrapolate.
2. The following formulas may be used:
 - $t/db = t/edb - \text{sensible capacity Btuh} / (1.10 \times \text{cfm})$
 - $t/wb = \text{Wet bulb temp. corresponding to enthalpy of air leaving evaporator coil (h/wb)}$
 - $h/wb = h/ewb - \text{total capacity Btuh} / (4.5 \times \text{cfm})$
where h/ewb = Enthalpy of air entering evap. coil
3. The SHC is based on 80F edb of air entering evap coil. Below 80F edb, subtract (corr factor x cfm) from SHC. Above 80F edb, add (corr factor x cfm) to SHC.

LEGEND	
MBH	= Total Capacity (Gross)
S/T	= Sensible to Total Ratio
KW	= Compressor Motor Power Input
IDB	= Indoor Dry Bulb
edb	= Entering Dry Bulb
ewb	= Entering Wet Bulb
t/db	= Leaving Dry Bulb
t/wb	= Leaving Wet Bulb
h/wb	= Enthalpy of Leaving Wet Bulb
SHC	= Sensible Heat Capacity

BYPASS FACTOR (BF)	ENTERING AIR DRY BULB					
	79	78	77	76	75	under 75
	81	82	83	84	85	over 85
Correction Factor						
.05	1.04	2.07	3.11	4.14	5.18	Use formulas shown below
.10	0.98	1.96	2.94	3.92	4.90	
.20	0.87	1.74	2.62	3.49	4.36	
.30	0.78	1.53	2.29	3.05	3.82	

Correction Factor = 1.10 x (1-BF) x (edb-80).

PGS Series PERFORMANCE DATA (CONT.)

CIRCULATING BLOWER PERFORMANCE - PGS072 - Standard Motor (Belt Drive)* (Horizontal Discharge)

Airflow CFM	EXTERNAL STATIC PRESSURE (in. wg)																			
	0.2		0.4		0.6		0.8		1.0		1.2		1.4		1.6		1.8		2.0	
	RPM	Watts	RPM	Watts	RPM	Watts	RPM	Watts	RPM	Watts	RPM	Watts	RPM	Watts	RPM	Watts	RPM	Watts	RPM	Watts
1800	919	561	1010	663	1095	771	1174	886	1250	1008	1321	1137	1390	1273	1455	1415	1518	1563	1579	1718
1900	960	648	1047	754	1129	867	1206	986	1279	1111	1348	1243	1415	1381	1479	1526	1541	1677	1601	1834
2000	1001	744	1085	855	1163	972	1238	1095	1309	1224	1377	1359	1442	1500	1505	1648	1565	1801	1624	1961
2100	1043	850	1123	965	1199	1086	1271	1213	1340	1346	1406	1485	1470	1629	1531	1780	1591	1936	1648	2098
2200	1085	966	1162	1086	1235	1211	1305	1342	1372	1479	1437	1621	1499	1769	1559	1923	1617	2082	-	-
2300	1127	1092	1201	1217	1272	1347	1340	1482	1405	1623	1468	1769	1529	1920	1587	2077	-	-	-	-
2400	1169	1229	1241	1359	1310	1493	1375	1633	1439	1778	1500	1928	1559	2083	-	-	-	-	-	-
2500	1212	1378	1281	1513	1348	1652	1412	1796	1473	1945	1533	2098	-	-	-	-	-	-	-	-
2600	1255	1539	1322	1678	1386	1822	1448	1970	1508	2124	-	-	-	-	-	-	-	-	-	-
2700	1298	1713	1363	1857	1425	2005	-	-	-	-	-	-	-	-	-	-	-	-	-	-
2800	1341	1899	1404	2048	-	-	-	-	-	-	-	-	-	-	-	-	-	-	-	-
2900	1384	2099	-	-	-	-	-	-	-	-	-	-	-	-	-	-	-	-	-	-
3000	-	-	-	-	-	-	-	-	-	-	-	-	-	-	-	-	-	-	-	-

LEGEND

Watts = Input Watts to motor.

* Motor drive range: 1070 to 1460 rpm. All other rpms require a field-supplied drive.

Maximum continuous bhp is 2.40.

CIRCULATING BLOWER PERFORMANCE - PGS090 - Standard Motor (Belt Drive)* (Horizontal Discharge)

Airflow CFM	EXTERNAL STATIC PRESSURE (in. wg)																			
	0.2		0.4		0.6		0.8		1.0		1.2		1.4		1.6		1.8		2.0	
	RPM	Watts	RPM	Watts	RPM	Watts	RPM	Watts	RPM	Watts	RPM	Watts	RPM	Watts	RPM	Watts	RPM	Watts	RPM	Watts
2250	505	527	586	687	658	859	723	1044	783	1242	838	1451	891	1673	941	1906	988	2150	-	-
2300	513	556	592	718	663	893	728	1080	787	1280	843	1492	895	1715	944	1949	991	2195	-	-
2400	528	617	605	785	675	965	738	1156	797	1360	851	1575	903	1801	952	2039	-	-	-	-
2500	543	683	618	857	686	1041	749	1238	806	1445	860	1664	911	1894	960	2135	-	-	-	-
2550	550	718	625	894	692	1082	754	1280	811	1490	865	1711	916	1943	964	2185	-	-	-	-
2600	558	754	632	933	698	1123	760	1324	816	1536	870	1759	920	1993	968	2237	-	-	-	-
2700	574	830	646	1015	711	1210	771	1416	827	1633	879	1859	929	2097	-	-	-	-	-	-
2800	589	912	660	1103	723	1303	782	1514	838	1735	889	1966	939	2207	-	-	-	-	-	-
2900	605	999	674	1196	736	1401	794	1617	848	1843	900	2078	-	-	-	-	-	-	-	-
3000	621	1092	688	1295	749	1506	806	1727	860	1957	910	2197	-	-	-	-	-	-	-	-
3100	637	1191	702	1400	763	1617	819	1842	871	2077	-	-	-	-	-	-	-	-	-	-
3200	653	1297	717	1511	776	1733	831	1964	883	2204	-	-	-	-	-	-	-	-	-	-
3300	670	1408	732	1629	790	1857	844	2093	-	-	-	-	-	-	-	-	-	-	-	-
3400	686	1526	747	1753	804	1987	857	2228	-	-	-	-	-	-	-	-	-	-	-	-
3500	703	1652	762	1884	818	2123	-	-	-	-	-	-	-	-	-	-	-	-	-	-
3600	719	1783	777	2022	-	-	-	-	-	-	-	-	-	-	-	-	-	-	-	-
3700	736	1923	793	2167	-	-	-	-	-	-	-	-	-	-	-	-	-	-	-	-
3750	744	1995	801	2243	-	-	-	-	-	-	-	-	-	-	-	-	-	-	-	-

LEGEND

Watts = Input Watts to motor.

* Motor drive range: 590 to 840 rpm. All other rpms require a field-supplied drive.

Maximum continuous bhp is 2.40.

PGS Series PERFORMANCE DATA (CONT.)

CIRCULATING BLOWER PERFORMANCE – PGS120 – Standard Motor (Belt Drive) (Horizontal Discharge)

Airflow CFM	EXTERNAL STATIC PRESSURE (in. wg)																			
	0.2		0.4		0.6		0.8		1.0		1.2		1.4		1.6		1.8		2.0	
	RPM	Watts	RPM	Watts	RPM	Watts	RPM	Watts	RPM	Watts	RPM	Watts	RPM	Watts	RPM	Watts	RPM	Watts	RPM	Watts
3000	555	630	629	765	696	904	757	1048	814	1198	867	1353	918	1513	966	1680	1012	1852	1056	2029
3100	568	686	641	825	706	968	766	1115	823	1269	876	1427	926	1590	973	1760	1019	1934	-	-
3200	582	745	652	888	717	1035	776	1186	832	1343	884	1504	934	1671	981	1843	1026	2020	-	-
3300	595	808	664	955	728	1106	786	1261	841	1421	893	1586	942	1755	988	1930	1033	2111	-	-
3400	609	874	677	1026	739	1181	797	1340	851	1503	902	1671	950	1844	996	2022	-	-	-	-
3500	623	945	689	1100	750	1259	807	1422	860	1589	911	1760	959	1937	-	-	-	-	-	-
3600	636	1019	702	1179	762	1341	817	1508	870	1679	920	1854	967	2033	-	-	-	-	-	-
3700	650	1097	714	1261	773	1428	828	1598	880	1772	929	1951	-	-	-	-	-	-	-	-
3800	664	1179	727	1347	785	1518	839	1693	890	1870	939	2053	-	-	-	-	-	-	-	-
3900	678	1266	740	1438	797	1613	850	1791	901	1973	-	-	-	-	-	-	-	-	-	-
4000	693	1356	753	1533	809	1712	861	1894	911	2080	-	-	-	-	-	-	-	-	-	-
4100	707	1451	766	1632	821	1816	873	2002	-	-	-	-	-	-	-	-	-	-	-	-
4200	721	1551	779	1736	833	1924	-	-	-	-	-	-	-	-	-	-	-	-	-	-
4300	735	1656	792	1845	846	2037	-	-	-	-	-	-	-	-	-	-	-	-	-	-
4400	750	1764	806	1958	-	-	-	-	-	-	-	-	-	-	-	-	-	-	-	-
4500	764	1879	819	2077	-	-	-	-	-	-	-	-	-	-	-	-	-	-	-	-
4600	779	1998	-	-	-	-	-	-	-	-	-	-	-	-	-	-	-	-	-	-
4700	-	-	-	-	-	-	-	-	-	-	-	-	-	-	-	-	-	-	-	-
4800	-	-	-	-	-	-	-	-	-	-	-	-	-	-	-	-	-	-	-	-
4900	-	-	-	-	-	-	-	-	-	-	-	-	-	-	-	-	-	-	-	-
5000	-	-	-	-	-	-	-	-	-	-	-	-	-	-	-	-	-	-	-	-

LEGEND

Watts = Input Watts to motor.

* Motor drive range: 685 to 935 rpm. All other rpms require a field-supplied drive.

Maximum continuous bhp is 2.40.

CIRCULATING BLOWER PERFORMANCE – PGS150 – Standard Motor (Belt Drive) (Horizontal Discharge)

Airflow CFM	EXTERNAL STATIC PRESSURE (in. wg)																			
	0.2		0.4		0.6		0.8		1.0		1.2		1.4		1.6		1.8		2.0	
	RPM	Watts	RPM	Watts	RPM	Watts	RPM	Watts	RPM	Watts	RPM	Watts	RPM	Watts	RPM	Watts	RPM	Watts	RPM	Watts
3700	676	1106	747	1328	811	1552	871	1779	927	2008	981	2240	1031	2473	1079	2709	1125	2948	1169	3189
3800	690	1185	760	1414	823	1644	882	1876	938	2111	990	2348	1040	2587	1088	2828	1133	3073	1170	3319
3900	705	1269	773	1503	835	1739	894	1977	948	2217	1000	2459	1050	2705	1097	2951	1142	3201	1186	3452
4000	719	1357	786	1597	848	1838	905	2082	959	2328	1011	2576	1059	2826	1106	3079	1151	3334	-	-
4100	734	1449	799	1695	860	1942	917	2192	970	2443	1021	2697	1069	2953	1116	3210	-	-	-	-
4200	748	1545	813	1797	872	2050	928	2305	981	2562	1031	2822	1079	3083	1125	3347	-	-	-	-
4300	763	1646	826	1903	885	2162	940	2423	992	2686	1042	2951	1089	3218	-	-	-	-	-	-
4400	778	1751	840	2014	898	2279	952	2546	1004	2814	1053	3085	1100	3357	-	-	-	-	-	-
4500	792	1860	853	2130	910	2401	964	2673	1015	2947	1064	3224	-	-	-	-	-	-	-	-
4600	807	1975	867	2250	923	2527	976	2805	1027	3085	1075	3367	-	-	-	-	-	-	-	-
4700	822	2094	881	2375	936	2658	989	2942	1038	3227	-	-	-	-	-	-	-	-	-	-
4800	837	2218	895	2505	949	2794	1001	3093	1050	3375	-	-	-	-	-	-	-	-	-	-
4900	852	2347	909	2640	963	2935	1014	3230	-	-	-	-	-	-	-	-	-	-	-	-
5000	867	2482	923	2781	976	3081	1026	3383	-	-	-	-	-	-	-	-	-	-	-	-
5100	882	2622	937	2926	989	3232	-	-	-	-	-	-	-	-	-	-	-	-	-	-
5200	897	2766	951	3077	1003	3389	-	-	-	-	-	-	-	-	-	-	-	-	-	-
5300	912	2917	966	3233	-	-	-	-	-	-	-	-	-	-	-	-	-	-	-	-
5400	927	3073	980	3395	-	-	-	-	-	-	-	-	-	-	-	-	-	-	-	-
5500	943	3234	-	-	-	-	-	-	-	-	-	-	-	-	-	-	-	-	-	-
5600	958	3402	-	-	-	-	-	-	-	-	-	-	-	-	-	-	-	-	-	-

LEGEND

Watts = Input Watts to motor.

* Motor drive range: 860 to 1080 rpm. All other rpms require a field-supplied drive.

Maximum continuous bhp is 3.70.

PGS Series PERFORMANCE DATA (CONT.)

FAN PERFORMANCE VERTICAL DISCHARGE UNITS

PGS072 (6 TONS) – STANDARD MOTOR (BELT DRIVE)*

Airflow (Cfm)	External Static Pressure (in. wg)														
	0.2			0.4			0.6			0.8			1.0		
	Rpm	Bhp	Watts	Rpm	Bhp	Watts	Rpm	Bhp	Watts	Rpm	Bhp	Watts	Rpm	Bhp	Watts
1800	967	0.65	579	1077	0.81	718	1172	0.96	856	1257	1.12	993	1334	1.27	1130
1900	1007	0.75	663	1115	0.91	811	1208	1.08	957	1291	1.24	1101	1368	1.40	1246
2000	1048	0.85	757	1153	1.03	913	1244	1.20	1066	1326	1.37	1219	1401	1.54	1371
2100	1090	0.97	859	1191	1.15	1023	1281	1.33	1185	1361	1.51	1345	1435	1.69	1505
2200	1131	1.09	970	1230	1.29	1143	1318	1.48	1313	1397	1.67	1481	1470	1.86	1649
2300	1173	1.23	1091	1269	1.43	1273	1355	1.63	1451	1433	1.83	1627	1505	2.03	1803
2400	1215	1.38	1223	1309	1.59	1413	1393	1.80	1600	1470	2.01	1784	1540	2.21	1967
2500	1258	1.54	1365	1349	1.76	1564	1431	1.98	1759	1506	2.20	1951	—	—	—
2600	1300	1.71	1518	1389	1.94	1726	1470	2.17	1929	1544	2.40	2130	—	—	—
2700	1343	1.90	1683	1430	2.14	1899	1509	2.38	2111	—	—	—	—	—	—
2800	1386	2.09	1860	1471	2.35	2085	—	—	—	—	—	—	—	—	—
2900	1429	2.31	2050	—	—	—	—	—	—	—	—	—	—	—	—
3000	—	—	—	—	—	—	—	—	—	—	—	—	—	—	—

PGS072 (6 TONS) – STANDARD MOTOR (BELT DRIVE)* (cont)

Airflow (Cfm)	External Static Pressure (in. wg)														
	0.2			0.4			0.6			0.8			1.0		
	Rpm	Bhp	Watts	Rpm	Bhp	Watts	Rpm	Bhp	Watts	Rpm	Bhp	Watts	Rpm	Bhp	Watts
1800	1406	1.43	1268	1473	1.58	1407	1535	1.74	1548	1595	1.90	1690	1652	2.06	1833
1900	1438	1.57	1391	1504	1.73	1537	1567	1.90	1685	1626	2.06	1833	1682	2.23	1983
2000	1471	1.72	1523	1536	1.89	1677	1598	2.06	1831	1657	2.24	1986	—	—	—
2100	1504	1.87	1665	1569	2.06	1825	1630	2.24	1986	—	—	—	—	—	—
2200	1538	2.04	1816	1602	2.23	1984	—	—	—	—	—	—	—	—	—
2300	1572	2.23	1978	—	—	—	—	—	—	—	—	—	—	—	—
2400	—	—	—	—	—	—	—	—	—	—	—	—	—	—	—
2500	—	—	—	—	—	—	—	—	—	—	—	—	—	—	—
2600	—	—	—	—	—	—	—	—	—	—	—	—	—	—	—
2700	—	—	—	—	—	—	—	—	—	—	—	—	—	—	—
2800	—	—	—	—	—	—	—	—	—	—	—	—	—	—	—
2900	—	—	—	—	—	—	—	—	—	—	—	—	—	—	—
3000	—	—	—	—	—	—	—	—	—	—	—	—	—	—	—

LEGEND

Bhp – Brake Horsepower input to fan

Watts – Input Watts to motor

*Motor drive range: 1070 to 1460 rpm. All other rpms require a field-supplied drive.

NOTES:

1. **Boldface** indicates field-supplied drive is required.
2. Maximum continuous Bhp is 2.40.
3. See General Notes for Fan Performance following this section.

PGS Series PERFORMANCE DATA (CONT.)

FAN PERFORMANCE VERTICAL DISCHARGE UNITS

PGS090 (7-1/2 TONS) – STANDARD MOTOR (BELT DRIVE)*															
Airflow (Cfm)	External Static Pressure (in. wg)														
	0.2			0.4			0.6			0.8			1.0		
	Rpm	Bhp	Watts	Rpm	Bhp	Watts	Rpm	Bhp	Watts	Rpm	Bhp	Watts	Rpm	Bhp	Watts
2250	513	0.58	540	593	0.75	702	663	0.94	873	726	1.13	1054	783	1.34	1245
2300	520	0.61	570	600	0.79	735	669	0.97	908	731	1.17	1092	789	1.38	1285
2400	535	0.68	633	613	0.86	803	681	1.05	983	743	1.26	1171	799	1.47	1369
2500	551	0.75	700	627	0.94	877	693	1.14	1062	754	1.35	1256	810	1.56	1459
2550	559	0.79	736	634	0.98	916	700	1.18	1104	760	1.39	1301	815	1.61	1506
2600	567	0.83	773	640	1.03	956	706	1.23	1147	766	1.44	1346	821	1.67	1554
2700	582	0.91	851	655	1.12	1040	719	1.33	1237	778	1.55	1441	832	1.77	1654
2800	598	1.00	935	669	1.21	1130	732	1.43	1333	790	1.65	1543	844	1.89	1761
2900	614	1.10	1024	683	1.31	1225	745	1.54	1434	802	1.77	1650	855	2.01	1873
3000	630	1.20	1119	698	1.42	1327	759	1.65	1542	815	1.89	1763	867	2.14	1992
3100	647	1.31	1220	713	1.54	1435	773	1.78	1655	828	2.02	1883	879	2.27	2117
3200	663	1.42	1328	728	1.66	1549	787	1.90	1776	841	2.15	2008	—	—	—
3300	680	1.55	1442	743	1.79	1669	801	2.04	1902	854	2.30	2141	—	—	—
3400	696	1.68	1563	758	1.93	1797	815	2.18	2036	—	—	—	—	—	—
3500	713	1.81	1690	774	2.07	1931	829	2.33	2177	—	—	—	—	—	—
3600	730	1.96	1825	789	2.22	2073	—	—	—	—	—	—	—	—	—
3700	747	2.11	1967	805	2.38	2221	—	—	—	—	—	—	—	—	—
3750	755	2.19	2041	—	—	—	—	—	—	—	—	—	—	—	—

PGS090 (7-1/2 TONS) – STANDARD MOTOR (BELT DRIVE)* (cont)															
Airflow (Cfm)	External Static Pressure (in. wg)														
	0.2			0.4			0.6			0.8			1.0		
	Rpm	Bhp	Watts	Rpm	Bhp	Watts	Rpm	Bhp	Watts	Rpm	Bhp	Watts	Rpm	Bhp	Watts
2250	837	1.55	1445	887	1.77	1655	934	2.01	1874	979	2.25	2102	—	—	—
2300	842	1.60	1488	891	1.82	1699	938	2.06	1920	983	2.31	2150	—	—	—
2400	852	1.69	1576	901	1.92	1792	948	2.16	2017	—	—	—	—	—	—
2500	862	1.79	1670	911	2.03	1890	957	2.27	2119	—	—	—	—	—	—
2550	867	1.84	1719	916	2.08	1941	962	2.33	2173	—	—	—	—	—	—
2600	872	1.90	1770	921	2.14	1995	966	2.39	2227	—	—	—	—	—	—
2700	883	2.01	1875	931	2.26	2104	—	—	—	—	—	—	—	—	—
2800	894	2.13	1986	—	—	—	—	—	—	—	—	—	—	—	—
2900	—	—	—	—	—	—	—	—	—	—	—	—	—	—	—
3000	—	—	—	—	—	—	—	—	—	—	—	—	—	—	—
3100	—	—	—	—	—	—	—	—	—	—	—	—	—	—	—
3200	—	—	—	—	—	—	—	—	—	—	—	—	—	—	—
3300	—	—	—	—	—	—	—	—	—	—	—	—	—	—	—
3400	—	—	—	—	—	—	—	—	—	—	—	—	—	—	—
3500	—	—	—	—	—	—	—	—	—	—	—	—	—	—	—
3600	—	—	—	—	—	—	—	—	—	—	—	—	—	—	—
3700	—	—	—	—	—	—	—	—	—	—	—	—	—	—	—
3750	—	—	—	—	—	—	—	—	—	—	—	—	—	—	—

LEGEND

Bhp – Brake Horsepower input to fan

Watts – Input Watts to motor

*Motor drive range: 590 to 840 rpm. All other rpms require a field-supplied drive.

NOTES:

1. **Boldface** indicates field-supplied drive is required.
2. Maximum continuous Bhp is 2.40.
3. See General Notes for Fan Performance following this section.

PGS Series PERFORMANCE DATA (CONT.)

FAN PERFORMANCE VERTICAL DISCHARGE UNITS

PGS120 (10 TONS) – STANDARD MOTOR (BELT DRIVE)*

Airflow (Cfm)	External Static Pressure (in. wg)														
	0.2			0.4			0.6			0.8			1.0		
	Rpm	Bhp	Watts	Rpm	Bhp	Watts	Rpm	Bhp	Watts	Rpm	Bhp	Watts	Rpm	Bhp	Watts
3000	726	0.75	656	793	0.94	822	853	1.14	997	910	1.35	1181	962	1.56	1373
3100	746	0.81	713	811	1.01	883	870	1.21	1062	926	1.42	1250	978	1.65	1447
3200	766	0.88	773	829	1.08	947	887	1.29	1131	942	1.51	1323	993	1.74	1524
3300	786	0.95	836	847	1.16	1016	905	1.37	1204	958	1.60	1400	1008	1.83	1604
3400	806	1.03	904	866	1.24	1088	922	1.46	1280	975	1.69	1481	1024	1.92	1689
3500	826	1.11	975	885	1.33	1163	940	1.55	1360	991	1.78	1565	1040	2.03	1778
3600	846	1.20	1050	904	1.42	1243	958	1.65	1444	1008	1.88	1654	1056	2.13	1870
3700	866	1.29	1129	923	1.51	1327	975	1.75	1532	1025	1.99	1746	1073	2.24	1967
3800	886	1.38	1212	942	1.61	1415	994	1.85	1625	1043	2.10	1843	1089	2.36	2068
3900	907	1.48	1299	961	1.72	1507	1012	1.96	1722	1060	2.21	1944	—	—	—
4000	927	1.58	1391	980	1.83	1603	1030	2.08	1823	1078	2.33	2049	—	—	—
4100	948	1.69	1487	1000	1.94	1704	1049	2.20	1928	—	—	—	—	—	—
4200	968	1.81	1588	1019	2.06	1809	1067	2.32	2038	—	—	—	—	—	—
4300	989	1.93	1694	1039	2.19	1920	—	—	—	—	—	—	—	—	—
4400	1009	2.06	1804	1058	2.32	2034	—	—	—	—	—	—	—	—	—
4500	1030	2.19	1919	—	—	—	—	—	—	—	—	—	—	—	—
4600	1051	2.32	2039	—	—	—	—	—	—	—	—	—	—	—	—
4700	—	—	—	—	—	—	—	—	—	—	—	—	—	—	—
4800	—	—	—	—	—	—	—	—	—	—	—	—	—	—	—
4900	—	—	—	—	—	—	—	—	—	—	—	—	—	—	—
5000	—	—	—	—	—	—	—	—	—	—	—	—	—	—	—

PGS120 (10 TONS) – STANDARD MOTOR (BELT DRIVE)* (cont)

Airflow (Cfm)	External Static Pressure (in. wg)														
	0.2			0.4			0.6			0.8			1.0		
	Rpm	Bhp	Watts	Rpm	Bhp	Watts	Rpm	Bhp	Watts	Rpm	Bhp	Watts	Rpm	Bhp	Watts
3000	1012	1.79	1574	1060	2.03	1781	1105	2.28	1997	—	—	—	—	—	—
3100	1027	1.88	1651	1073	2.12	1863	1118	2.37	2081	—	—	—	—	—	—
3200	1041	1.97	1732	1088	2.22	1947	—	—	—	—	—	—	—	—	—
3300	1056	2.07	1817	1102	2.32	2036	—	—	—	—	—	—	—	—	—
3400	1071	2.17	1905	—	—	—	—	—	—	—	—	—	—	—	—
3500	1087	2.28	1998	—	—	—	—	—	—	—	—	—	—	—	—
3600	1102	2.39	2094	—	—	—	—	—	—	—	—	—	—	—	—
3700	—	—	—	—	—	—	—	—	—	—	—	—	—	—	—
3800	—	—	—	—	—	—	—	—	—	—	—	—	—	—	—
3900	—	—	—	—	—	—	—	—	—	—	—	—	—	—	—
4000	—	—	—	—	—	—	—	—	—	—	—	—	—	—	—
4100	—	—	—	—	—	—	—	—	—	—	—	—	—	—	—
4200	—	—	—	—	—	—	—	—	—	—	—	—	—	—	—
4300	—	—	—	—	—	—	—	—	—	—	—	—	—	—	—
4400	—	—	—	—	—	—	—	—	—	—	—	—	—	—	—
4500	—	—	—	—	—	—	—	—	—	—	—	—	—	—	—
4600	—	—	—	—	—	—	—	—	—	—	—	—	—	—	—
4700	—	—	—	—	—	—	—	—	—	—	—	—	—	—	—
4800	—	—	—	—	—	—	—	—	—	—	—	—	—	—	—
4900	—	—	—	—	—	—	—	—	—	—	—	—	—	—	—
5000	—	—	—	—	—	—	—	—	—	—	—	—	—	—	—

LEGEND

Bhp – Brake Horsepower input to fan

Watts – Input Watts to motor

*Motor drive range: 685 to 935 rpm. All other rpms require a field-supplied drive.

NOTES:

1. **Boldface** indicates field-supplied drive is required.
2. Maximum continuous Bhp is 2.40.
3. See General Notes for Fan Performance following this section.

PGS Series PERFORMANCE DATA (CONT.)

FAN PERFORMANCE VERTICAL DISCHARGE UNITS

PGS150 (12-1/2 TONS) - STANDARD MOTOR (BELT DRIVE)*															
Airflow (Cfm)	External Static Pressure (in. wg)														
	0.2			0.4			0.6			0.8			1.0		
	Rpm	Bhp	Watts	Rpm	Bhp	Watts	Rpm	Bhp	Watts	Rpm	Bhp	Watts	Rpm	Bhp	Watts
3700	728	1.36	1266	789	1.58	1473	848	1.81	1686	904	2.04	1906	957	2.29	2132
3800	744	1.46	1361	804	1.69	1572	861	1.92	1790	916	2.16	2015	969	2.41	2246
3900	760	1.57	1460	819	1.80	1676	875	2.04	1899	929	2.28	2128	981	2.53	2364
4000	777	1.68	1563	834	1.91	1785	889	2.16	2012	942	2.41	2247	993	2.67	2487
4100	793	1.79	1672	850	2.04	1899	904	2.29	2132	956	2.54	2371	1006	2.80	2615
4200	810	1.92	1786	865	2.16	2018	918	2.42	2255	969	2.68	2499	1018	2.95	2748
4300	826	2.04	1906	880	2.30	2142	932	2.56	2385	983	2.82	2633	1031	3.10	2888
4400	843	2.18	2031	896	2.44	2272	947	2.70	2520	996	2.97	2773	1044	3.25	3032
4500	860	2.32	2161	912	2.58	2408	962	2.85	2660	1010	3.13	2918	1057	3.41	3182
4600	876	2.46	2297	927	2.73	2549	977	3.01	2807	1024	3.29	3070	1070	3.58	3338
4700	893	2.62	2439	943	2.89	2696	992	3.17	2958	1038	3.46	3226	—	—	—
4800	910	2.77	2587	959	3.06	2849	1007	3.34	3116	1053	3.63	3390	—	—	—
4900	927	2.94	2741	975	3.23	3008	1022	3.52	3280	—	—	—	—	—	—
5000	944	3.11	2901	991	3.40	3173	1037	3.70	3451	—	—	—	—	—	—
5100	961	3.29	3068	1007	3.59	3345	—	—	—	—	—	—	—	—	—
5200	978	3.48	3241	—	—	—	—	—	—	—	—	—	—	—	—
5300	995	3.67	3420	—	—	—	—	—	—	—	—	—	—	—	—
5400	—	—	—	—	—	—	—	—	—	—	—	—	—	—	—
5500	—	—	—	—	—	—	—	—	—	—	—	—	—	—	—
5600	—	—	—	—	—	—	—	—	—	—	—	—	—	—	—
5700	—	—	—	—	—	—	—	—	—	—	—	—	—	—	—
5800	—	—	—	—	—	—	—	—	—	—	—	—	—	—	—
5900	—	—	—	—	—	—	—	—	—	—	—	—	—	—	—
6000	—	—	—	—	—	—	—	—	—	—	—	—	—	—	—

PGS150 (12-1/2 TONS) - STANDARD MOTOR (BELT DRIVE)* (cont)															
Airflow (Cfm)	External Static Pressure (in. wg)														
	0.2			0.4			0.6			0.8			1.0		
	Rpm	Bhp	Watts	Rpm	Bhp	Watts	Rpm	Bhp	Watts	Rpm	Bhp	Watts	Rpm	Bhp	Watts
3700	1008	2.54	2364	1058	2.79	2602	1106	3.05	2846	1152	3.32	3094	1198	3.59	3348
3800	1019	2.66	2482	1068	2.92	2725	1116	3.19	2972	1162	3.46	3226	—	—	—
3900	1031	2.79	2605	1079	3.06	2852	1126	3.33	3104	1171	3.61	3362	—	—	—
4000	1042	2.93	2733	1090	3.20	2984	1136	3.48	3241	—	—	—	—	—	—
4100	1054	3.07	2866	1101	3.35	3122	1146	3.63	3383	—	—	—	—	—	—
4200	1066	3.22	3004	1112	3.50	3264	—	—	—	—	—	—	—	—	—
4300	1078	3.38	3148	1123	3.66	3413	—	—	—	—	—	—	—	—	—
4400	1090	3.54	3297	—	—	—	—	—	—	—	—	—	—	—	—
4500	1103	3.70	3451	—	—	—	—	—	—	—	—	—	—	—	—
4600	—	—	—	—	—	—	—	—	—	—	—	—	—	—	—
4700	—	—	—	—	—	—	—	—	—	—	—	—	—	—	—
4800	—	—	—	—	—	—	—	—	—	—	—	—	—	—	—
4900	—	—	—	—	—	—	—	—	—	—	—	—	—	—	—
5000	—	—	—	—	—	—	—	—	—	—	—	—	—	—	—
5100	—	—	—	—	—	—	—	—	—	—	—	—	—	—	—
5200	—	—	—	—	—	—	—	—	—	—	—	—	—	—	—
5300	—	—	—	—	—	—	—	—	—	—	—	—	—	—	—
5400	—	—	—	—	—	—	—	—	—	—	—	—	—	—	—
5500	—	—	—	—	—	—	—	—	—	—	—	—	—	—	—
5600	—	—	—	—	—	—	—	—	—	—	—	—	—	—	—
5700	—	—	—	—	—	—	—	—	—	—	—	—	—	—	—
5800	—	—	—	—	—	—	—	—	—	—	—	—	—	—	—
5900	—	—	—	—	—	—	—	—	—	—	—	—	—	—	—
6000	—	—	—	—	—	—	—	—	—	—	—	—	—	—	—

LEGEND

Bhp - Brake Horsepower input to fan

Watts - Input Watts to motor

*Motor drive range: 860 to 1080 rpm. All other rpms require a field-supplied drive.

NOTES:

1. **Boldface** indicates field-supplied drive is required.
2. Maximum continuous Bhp is 3.70.
3. See General Notes for Fan Performance following this section.

GENERAL NOTES FOR FAN PERFORMANCE TABLES:

1. Extensive motor and electrical testing on these units ensures that the full range of the motor can be utilized with confidence. Using your fan motors up to the wattage ratings shown will not result in nuisance tripping or premature motor failure. Unit warranty will not be affected.
2. Values include losses for filters, unit casing, and wet coils.
3. Use of a field-supplied motor may affect wire sizing.
4. Interpolation is permissible. Do not extrapolate.

PGS Series PERFORMANCE DATA (CONT.)

Evaporator-Fan Motor Efficiency	
Unit PGS	Motor Efficiency (%)
072	84
090-120	80
150	87

All indoor-fan motors 5 hp and larger meet the minimum efficiency requirements as established by the Energy Policy Act of 1992 (EPACT) effective October 24, 1997.

EVAPORATOR-FAN MOTOR PERFORMANCE

Unit PGS	Evaporator-Fan Motor	Unit Voltage	Max. Acceptable Continuous BHP*	Max. Acceptable Operating Watts	Max. AMP Draw
072	Standard	208/230	2.40	2120	5.2
		460			3.0
090	Standard	208/230	2.40	2120	6.7
		460			3.0
120	Standard	208/230	2.40	2120	6.7
		460			3.0
150	Standard	208/230	3.70	3313	12.2
		460			5.5

LEGEND

BHP = Brake Horsepower

* Extensive motor and electrical testing on these units ensures that the full horsepower range of the motors can be utilized with confidence. Using your

fan motors up to the horsepower ratings shown in this table will not result in nuisance tripping or premature motor failure. Unit Warranty will not be affected.

FAN RPM MOTOR PULLEY SETTINGS

Unit PGS	MOTOR PULLEY TURNS OPEN												
	0	1/2	1	1-1/2	2	2-1/2	3	3-1/2	4	4-1/2	5	5-1/2	6
072	1460	1420	1380	1345	1305	1265	1225	1185	1150	1110	1070	-	-
090	840	815	790	765	740	715	690	665	635	615	590	-	-
120	935	910	885	860	835	810	785	760	735	710	685	-	-
150	1080	1060	1035	1015	990	970	950	925	905	880	860	-	-

TYPICAL INSTALLATIONS

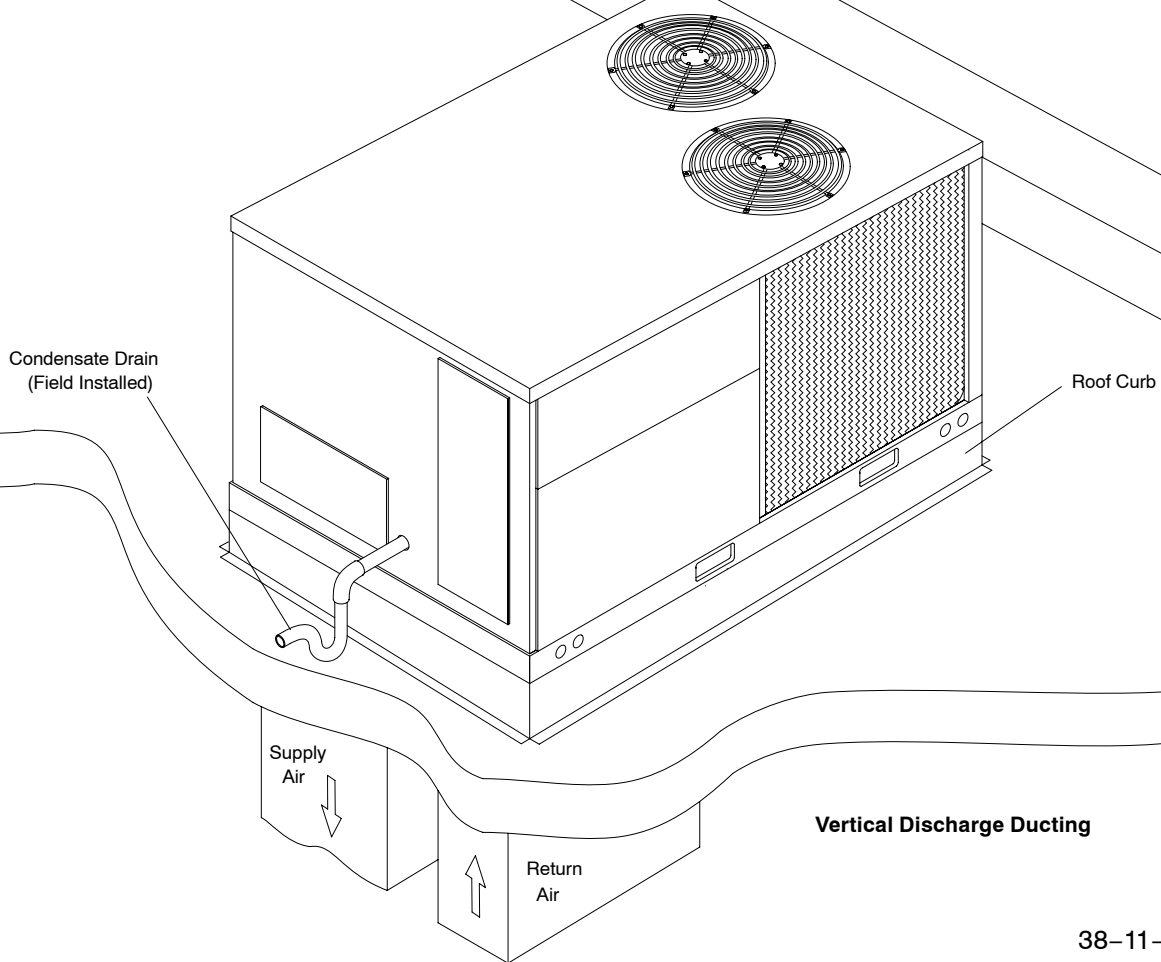
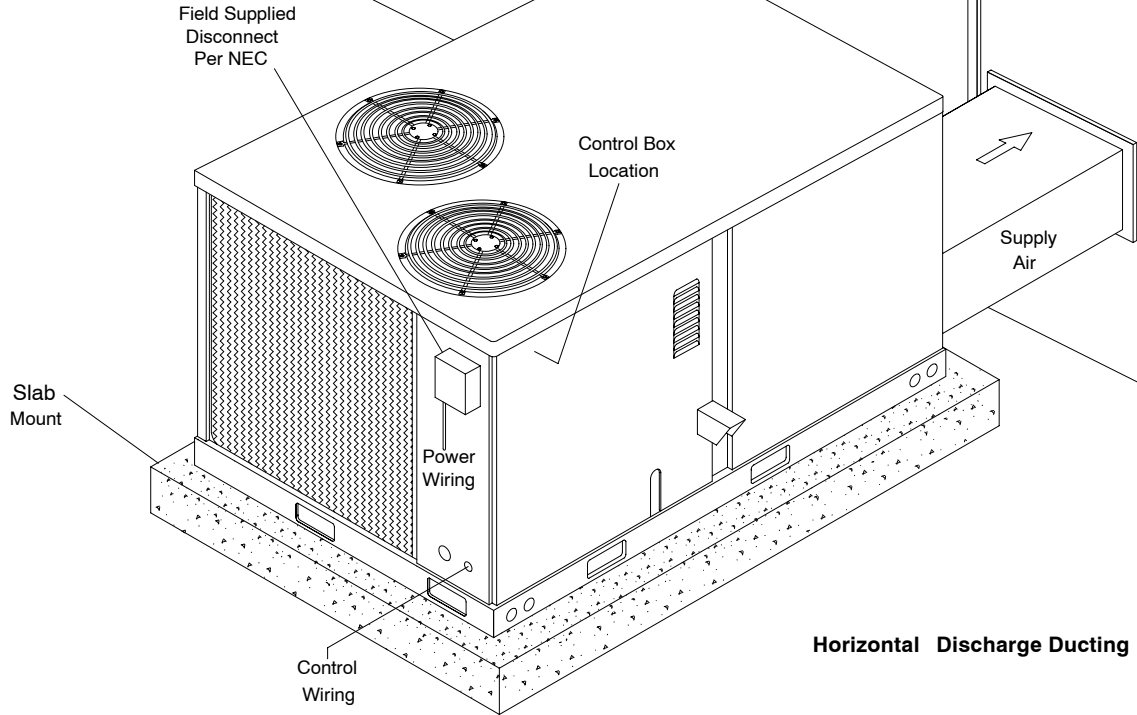

38-11-37

PGS072 ACCESSORIES
AXB035C*A

ROOF CURBS

Description	Model Number	Where Used
8" High *	AXB035CLA	072
14" High *	AXB035CMA	072
24" High *	AXB035CHA	072

CURB ADAPTOR

Description	Model Number	Where Used *
Curb Adaptor	AXB035CAA	072
Curb Adaptor With Duct	AXB035CBA	072

* Used with AXB030 curbs

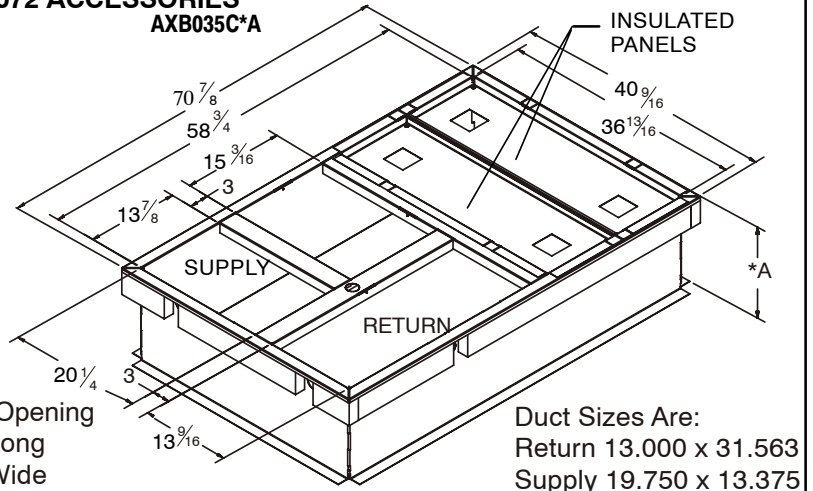

ECONOMIZER - DOWNFLOW

Description	Model Number	Where Used
Fully Modulating	AXB035EMA	072
Three Position	AXB035EPA	072

AXB035E*A

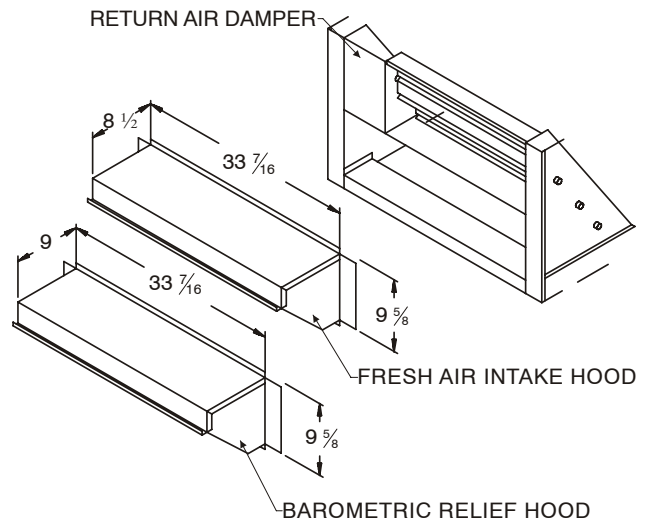

ECONOMIZER - HORIZONTAL

Description	Model Number	Where Used
Fully Modulating	AXB035HEA	072
Three Position	AXB035HPA	072

AXB035H*A

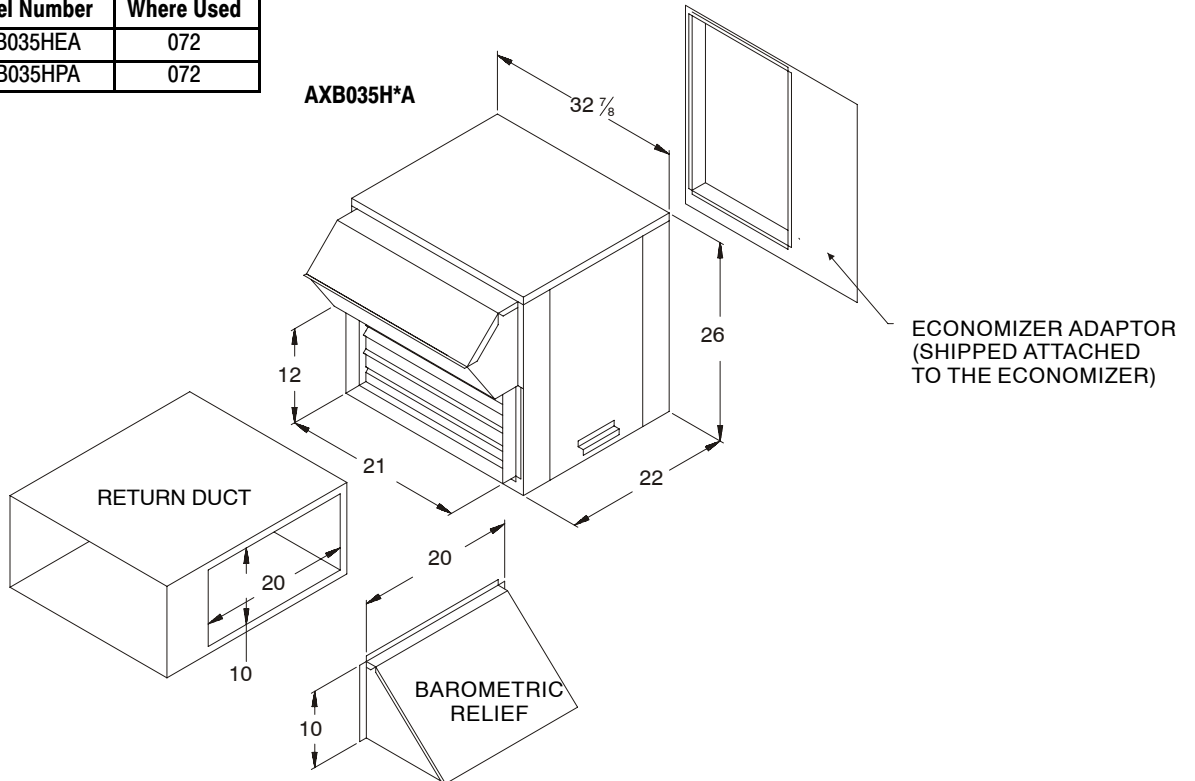

PGS072 ACCESSORIES (Cont.)

FRESH AIR DAMPER

Description	Model Number	Where Used
Manual	AXB035FAA	072
Motorized	AXB035FMA	072

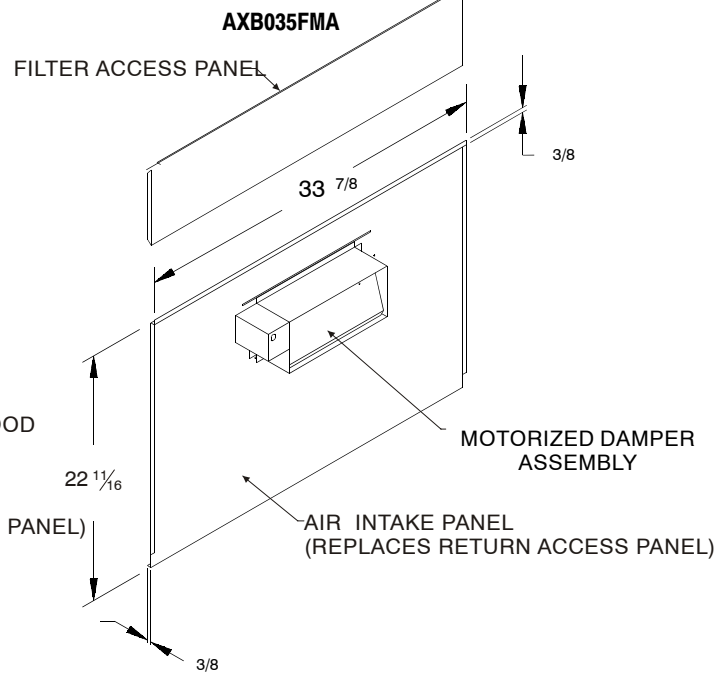
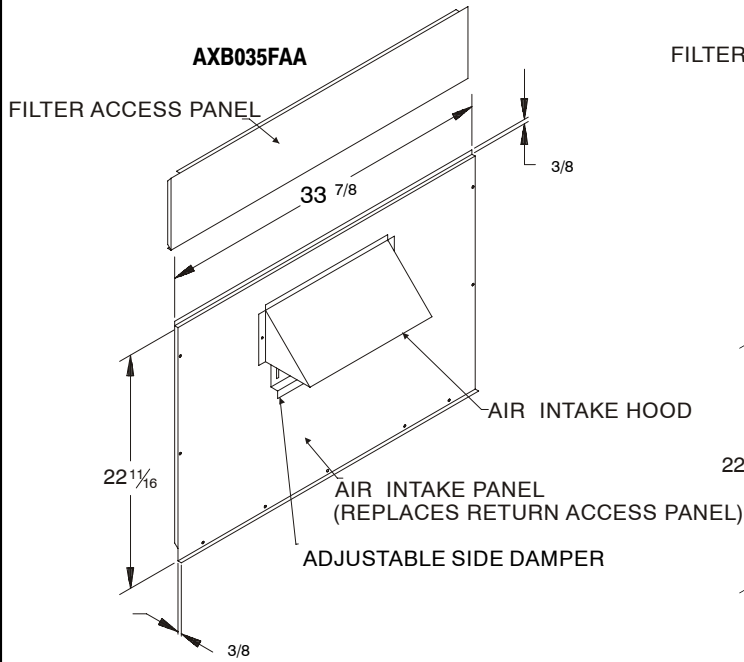

COIL PROTECTION

Description	Model Number	Where Used
Hail Guard	AXB036HGA	072

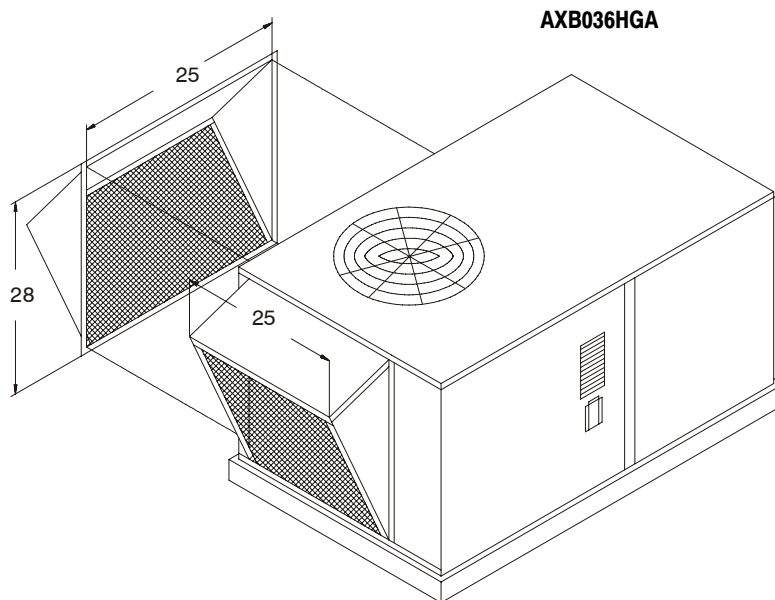

PGS072 ACCESSORIES (Cont.)

CONCENTRIC DUCT KIT

Description	Model Number	Where Used
20" Round.	AXB035CTA	072

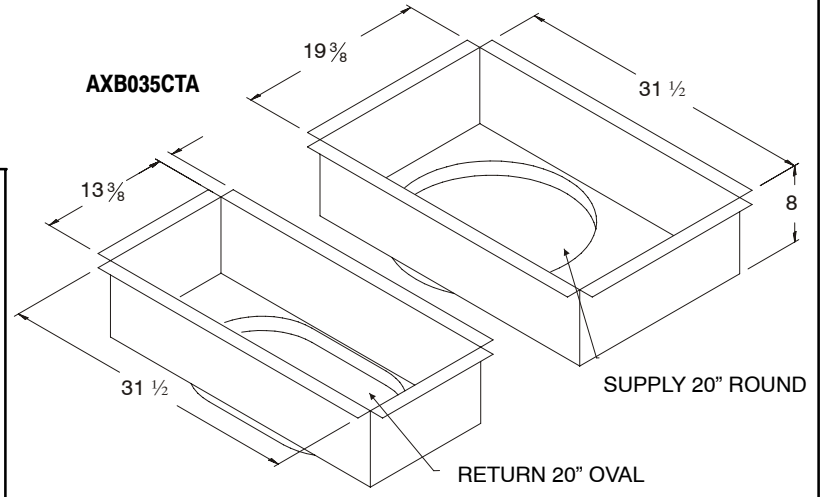

PERFORMANCE DATA ON NEXT PAGE

CONCENTRIC DIFFUSER

Description	Model Number	Used With
Flush Mount	AXB030CFA	072
Flush Mount	AXB040CFA	072
Step Down	AXB030CSA	072
Step Down	AXB040CSA	072

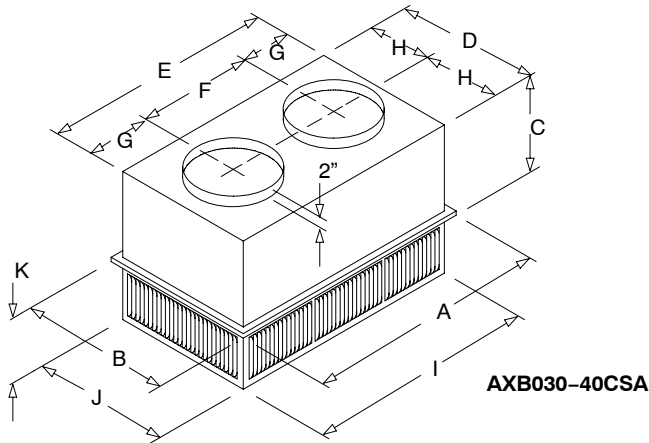

CONCENTRIC DIFFUSER (Step Down)

Model Number	A	B	C	D	E	F	G	H	I	J	K	Duct Size
AXB030CSA	47-5/8	23-5/8	11-3/8	21-1/2	45-1/2	22-1/2	11-1/2	10-3/4	45-1/2	21-1/2	7-1/8	18" RD
AXB040CSA	47-5/8	29-5/8	14-3/8	27-1/2	45-1/2	22-1/2	11-1/2	13-3/4	45-1/2	27-1/2	8-1/8	20" RD

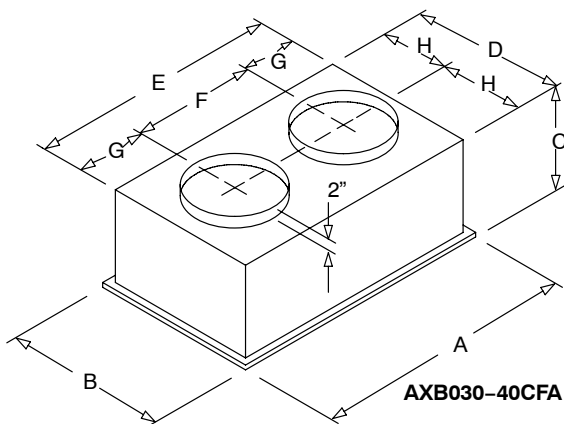

CONCENTRIC DIFFUSER (Flush Mount)

Model Number	A	B	C	D	E	F	G	H	Duct Size
AXB030CFA	47-5/8	23-5/8	13-1/2	21	45	22-1/2	11-1/4	10-1/2	18" RD
AXB040CFA	47-5/8	29-5/8	16-5/8	27	45	22-1/2	11-1/4	13-1/2	20" RD

PGS072 ACCESSORIES (Cont.)

CSA SERIES STEP-DOWN PERFORMANCE					
Part No. AXB	CFM	Static Pressure In. WC	Throw Feet	Neck / Jet Velocity FPM	db Sound Levels
030CSA	1200	.17	11-18	421	20
	1400	.20	12-19	491	20
	1600	.24	12-20	561	20
	1800	.30	13-21	632	20
	2000	.36	14-23	702	20
	2200	.40	16-25	772	20
040CSA	2600	.17	24-29	669	20
	2800	.20	25-30	720	25
	3000	.25	27-33	772	25
	3200	.31	28-35	823	25
	3400	.37	30-37	874	30

CFA SERIES FLUSH MOUNT PERFORMANCE						
Part No. AXB	CFM	Static Pressure In. WC	Throw Feet	Neck Velocity FPM	Jet Velocity FPM	db Sound Level
030CFA	1000	.14	15-20	391	694	20
	1200	.17	16-22	469	833	25
	1400	.20	17-24	547	972	30
	1600	.24	18-25	625	1111	30
	1800	.30	20-28	703	1250	35
	2000	.36	21-29	781	1389	40
	2200	.40	22-30	859	1528	40
040CFA	2600	.17	19-24	663	1294	30
	2800	.20	20-28	714	1393	35
	3000	.25	21-29	765	1492	35
	3200	.31	22-29	816	1592	40
	3400	.37	22-30	867	1692	40

CSA/CFA NOTES:

1. All data is based on the Air Diffusion Council guidelines.
2. Throw data is based on Terminal Velocities of 75 FPM using isothermal air.
3. Throw is based on diffuser blades being directed in a straight pattern.
4. Actual sound levels are less than those shown.
5. Minimum height 9' above floor.

NATURAL TO LP CONVERSION KIT	
Model Number	Used With
AXB035LPA (1175706)	072†
LOW AMBIENT KIT	
Model Number	Used With
AXB035LAA	072
THRU-THE-BASE POWER KIT	
Model Number	Used With
AXB035PKA	072

* Available thru service parts only

† For high heat models

PGS072 ACCESSORIES (Cont.)

POWER EXHAUST

Description	Model Number	Where Used
208/230 Volt	AXB035PEH	072
460 Volt	AXB035PEL	072

POWER EXHAUST PERFORMANCE DATA

Model	Volt/Phase/ Hertz	Motor			Unit								
		Qty	HP	RPM	Cir. Qty	LRA	FLA	MCA	Fuse Size	@0.0		@0.3	
										CFM	RPM	CFM	RPM
AXB035PEH	208-230/1/60	1	1	1725	1	10.2	4.3	5.4	10	2400	1725	2100	1725
AXB035PEL	460/1/60	1	1	1625	1	4.1	1.7	2.2	4	2300	625	2000	1625

NOTE: Power exhaust is wired single phase, drop third leg when installing.

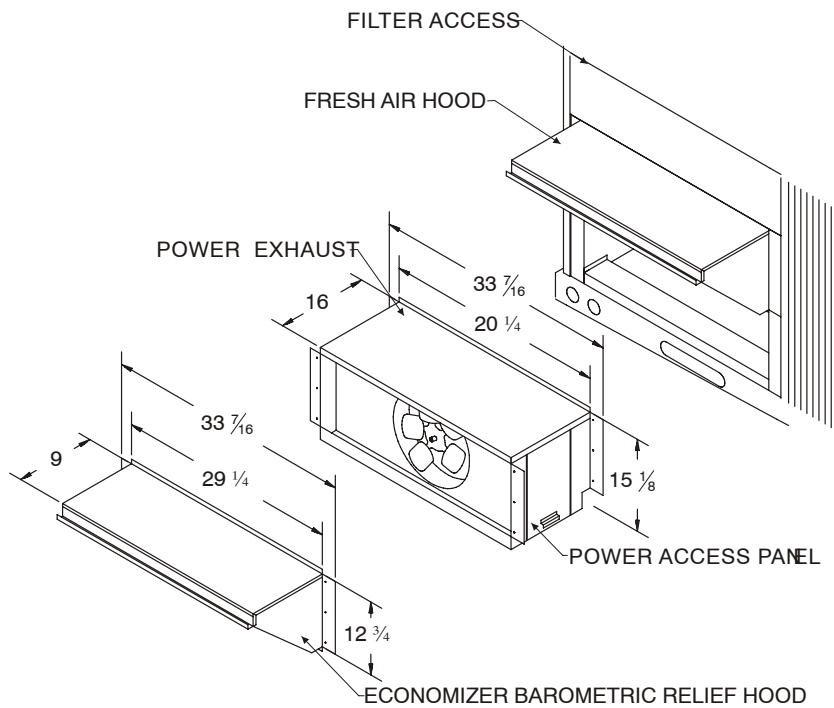

PGS090 - 150 ACCESSORIES

ROOF CURBS

Description	Model Number	Where Used
8" High *	AXB045CLA	090, 120, 150
14" High *	AXB045CMA	090, 120, 150
24" High *	AXB045CHA	090, 120, 150

* A Dimension

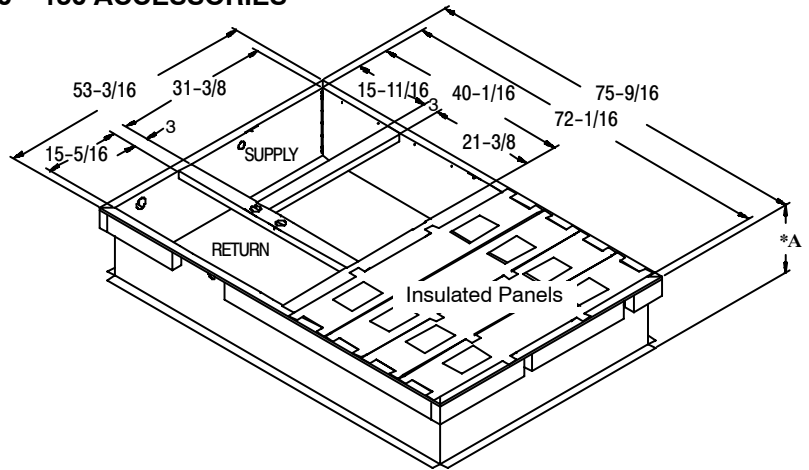

ECONOMIZER - DOWNFLOW

Description	Model Number	A Dimension	B Dimension	Where Used
Fully Modulating	AXB145EMA	13-3/4"	12-3/4"	090
	AXB245EMA	16-1/2"	17-3/4"	120, 150
Three Position	AXB145EPA	13-3/4"	12-3/4"	090
	AXB245EPA	16-1/2"	17-3/4"	120, 150

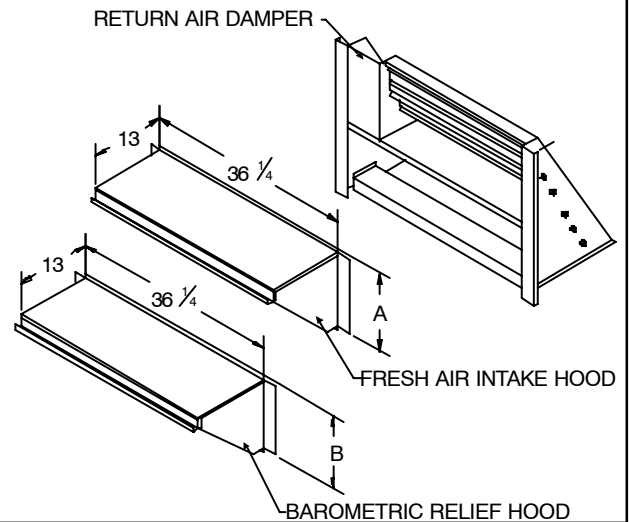

ECONOMIZER - HORIZONTAL

Description	Model Number	Where Used
Fully Modulating	AXB145HEA	090
	AXB245HEA	120, 150
Three Position	AXB145HPA	090
	AXB245HPA	120, 150

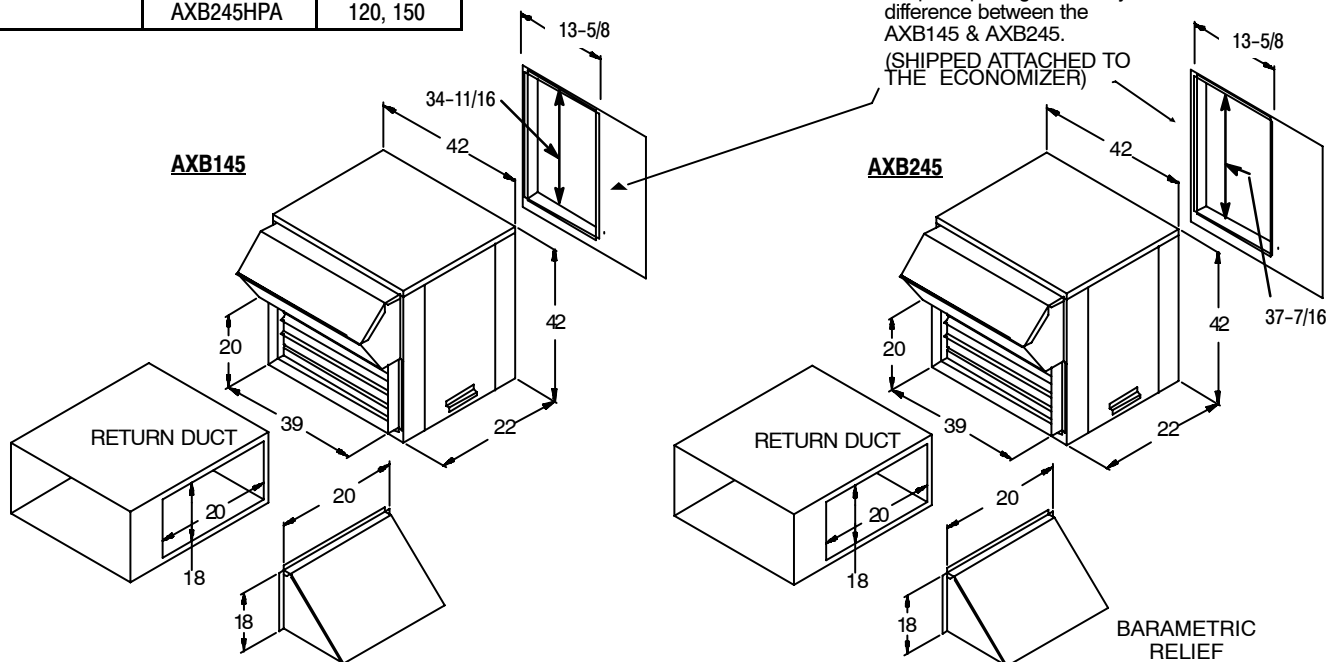

PGS090 – 150 ACCESSORIES (Cont.)

FRESH AIR DAMPER

Description	Model Number	A Dimension	Where Used
Manual	AXB145FAA	27-15/16	90, 102
	AXB245FAA	32-1/2	120, 150
Motorized	AXB145FMA	27-15/16	090
	AXB245FMA	32-1/2	120, 150

FILTER ACCESS PANEL

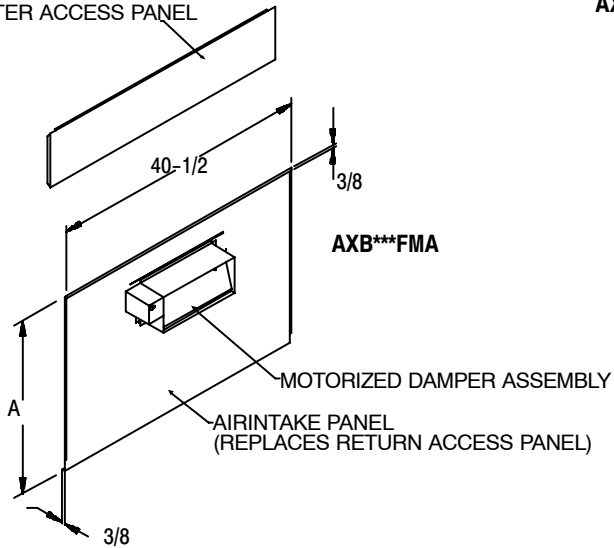

FILTER ACCESS PANEL

AXB***FAA

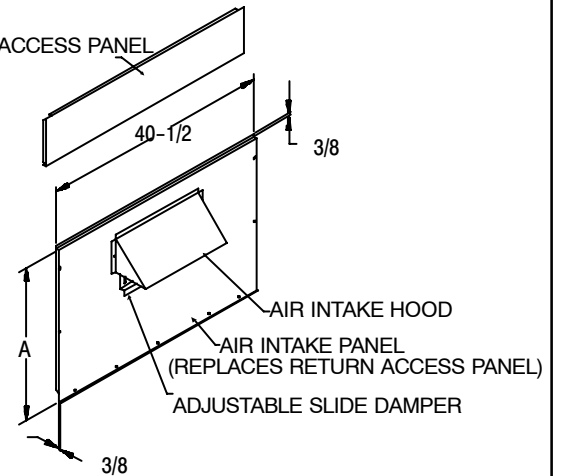

COIL PROTECTION

DIMENSIONS

Description	Model Number	Where Used	A	B
Coil Guard	AXB145CGA	090	44	37
	AXB245CGA	120, 150	45-3/8	45
Hail Guard	AXB145HGA	090	42	36
	AXB245HGA	120, 150	43-3/8	44

AXB***CGA

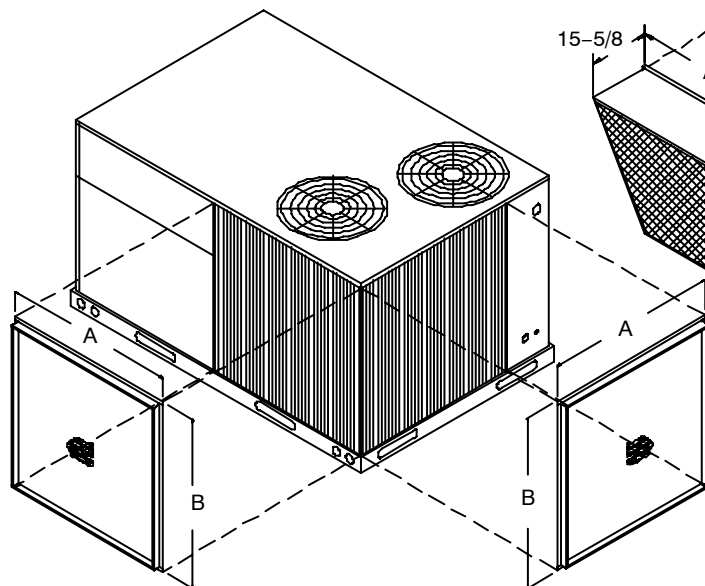

AXB***HGA

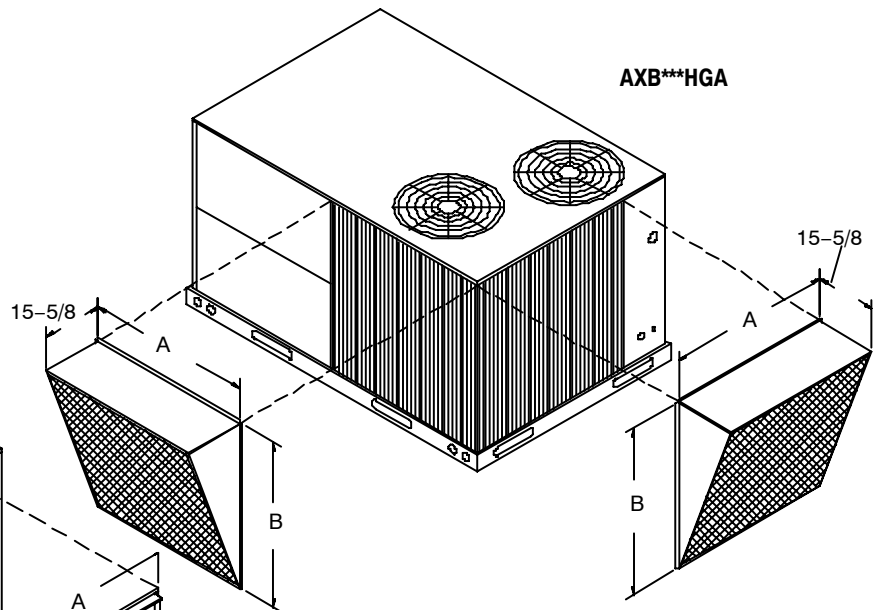

PGS090 - 150 ACCESSORIES (Cont.)

CONCENTRIC DUCT KIT

Description	Model Number	Where Used
20" Round	AXB445CTA	090
18" x 28" Rect.	AXB545CTA	120
18" x 32" Rect.	AXB645CTA	150

AXB445CTA
SHOWN

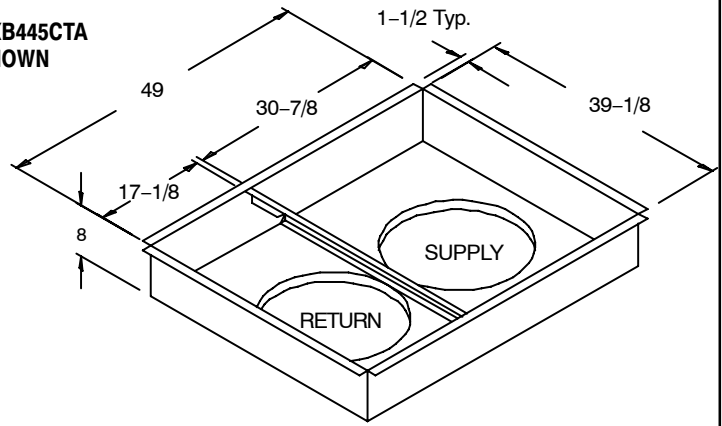

PERFORMANCE DATA ON NEXT PAGE

CONCENTRIC DIFFUSER

Description	Model Number	Used With
Flush Mount	AXB040CFA	AXB445CTA
Flush Mount	AXB045CFA	AXB545CTA
Flush Mount	AXB050CFA	AXB645CTA
Step Down	AXB040CSA	AXB445CTA
Step Down	AXB045CSA	AXB545CTA
Step Down	AXB050CSA	AXB645CTA

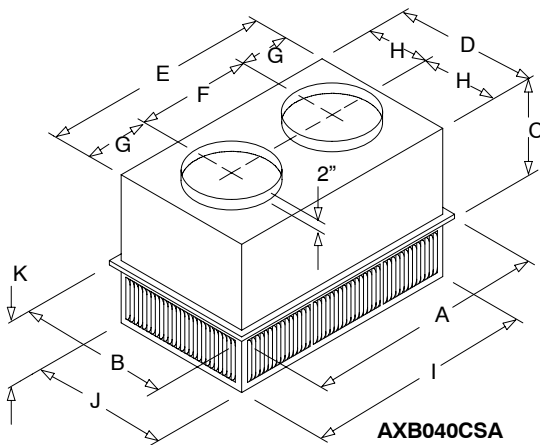

AXB040CSA

ANTI-SWEAT
GASKET

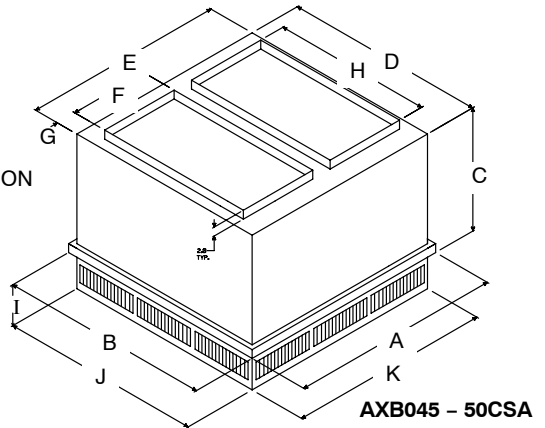
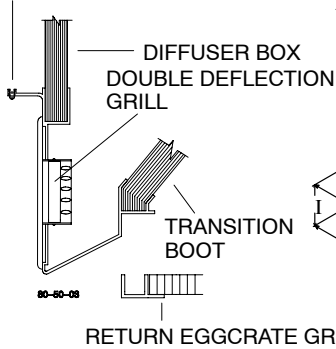

AXB045 - 50CSA

CONCENTRIC DIFFUSER (Step Down)

Model Number	A	B	C	D	E	F	G	H	I	J	K	Duct Size
AXB040CSA	47-5/8	29-3/8	14-3/8	27-1/2	45-1/2	22-1/2	11-1/2	13-3/4	45-1/2	27-1/2	8-1/8	20" RD
AXB045CSA	47-5/8	35-5/8	20-5/8	33-1/2	45-1/2	18	2-1/2	28	9-1/8	33-1/2	45-1/2	18 x 28
AXB050CSA	47-5/8	41-5/8	25-7/8	45-1/2	45-1/2	18	2-1/2	32	9-1/8	39-1/2	45-1/2	18 x 32

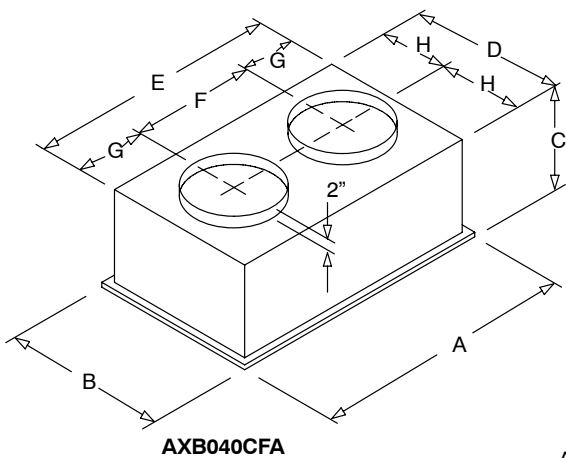

AXB040CFA

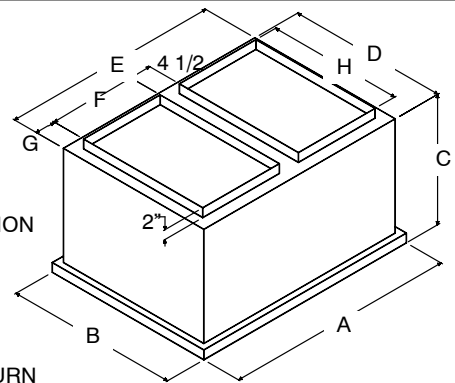
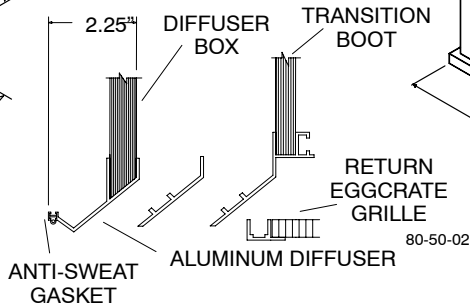

AXB045 - 50CFA

CONCENTRIC DIFFUSER (Flush Mount)

Model Number	A	B	C	D	E	F	G	H	Duct Size
AXB040CFA	47-5/8	29-5/8	16-5/8	27	45	22-1/2	11-1/4	13-1/2	20" RD
AXB045CFA	47-5/8	35-5/8	21-3/4	33	45	18	2-1/4	28	18 x 28
AXB050CFA	47-5/8	41-5/8	29-1/4	39	45	18	2-1/4	32	18 x 32

PGS090 – 150 ACCESSORIES (Cont.)

CSA SERIES STEP-DOWN PERFORMANCE					
Part No. AXB	CFM	Static Pressure In. WC	Throw Feet	Neck / Jet Velocity FPM	db Sound Levels
040CSA	2600	.17	24-29	669	20
	2800	.20	25-30	720	25
	3000	.25	27-33	772	25
	3200	.31	28-35	823	25
	3400	.37	30-37	874	30
045CSA	3600	.17	25-33	851	30
	3800	.18	27-35	898	30
	4000	.21	29-37	946	30
	4200	.24	32-40	993	30
	4400	.27	34-42	1040	30
050CSA	4400	.29	25-30	733	30
	4600	.31	26-31	767	30
	4800	.32	27-32	800	30
	5000	.34	28-33	833	30
	5200	.36	28-34	867	30
	5400	.39	29-35	900	30

CFA SERIES FLUSH MOUNT PERFORMANCE						
Part No. AXB	CFM	Static Pressure In. WC	Throw Feet	Neck Velocity FPM	Jet Velocity FPM	db Sound Level
040CFA	2600	.17	19-24	663	1294	30
	2800	.20	20-28	714	1393	35
	3000	.25	21-29	765	1492	35
	3200	.31	22-29	816	1592	40
	3400	.37	22-30	867	1692	40
045CFA	3600	.17	22-29	844	1646	35
	3800	.18	22-30	891	1737	40
	4000	.21	24-33	938	1829	40
	4200	.24	26-35	985	1920	40
	4400	.27	28-37	1032	2011	40
050CFA	4600	.31	25-34	922	1795	40
	4800	.32	26-35	962	1873	40
	5000	.34	27-36	1002	1951	40
	5200	.36	30-39	1043	2029	45
	5400	.39	32-41	1083	2107	45

CSA/CFA NOTES:

1. All data is based on the Air Diffusion Council guidelines.
2. Throw data is based on Terminal Velocities of 75 FPM using isothermal air.
3. Throw is based on diffuser blades being directed in a straight pattern.
4. Actual sound levels are less than those shown.
5. Minimum height 9' above floor.

NATURAL TO LP CONVERSION KIT	
Model Number	Used With
AXB345LPA	090 - 150 †
LOW AMBIENT KIT	
Model Number	Used With
AXB045LAA	090 - 150
THRU-THE-BASE POWER KIT	
Model Number	Used With
AXB045PKA	090 - 150
With 1-1/4" Power and 3/4" Gas Connections.	
† For high heat models	

PGS090 – 150 ACCESSORIES (Cont.)

POWER EXHAUST

Description	Model Number	Where Used
208/230 Volt	AXB145PEH	090
460 Volt	AXB145PEL	090
208/230 Volt	AXB245PEH	120, 150
460 Volt	AXB245PEL	120, 150

POWER EXHAUST PERFORMANCE DATA

Model	Volt/Phase/ Hertz	Motor			Unit										
		Qty	HP	RPM	Cir. Qty	LRA	FLA	MCA	Fuse Size	@0.0		@0.1	@0.3		
										CFM	RPM	CFM	CFM	RPM	
AXB145PEH	208-230/1/60	1	1/2	1725	1	10.2	4.3	5.4	8	2400	1725	N/A	2100	1725	
AXB145PEL	460/1/60	1	1/2	1625	1	4.1	1.7	2.2	5	2300	1625	N/A	2000	1625	
AXB245PEH	208-230/1/60	1	3/4	1075	1	24.9	5.0	6.3	10	N/A	N/A	4800	N/A	N/A	
AXB245PEL	460/1/60	1	3/4	1075	1	N/A	2.2	2.8	5	N/A	N/A	4800	N/A	N/A	

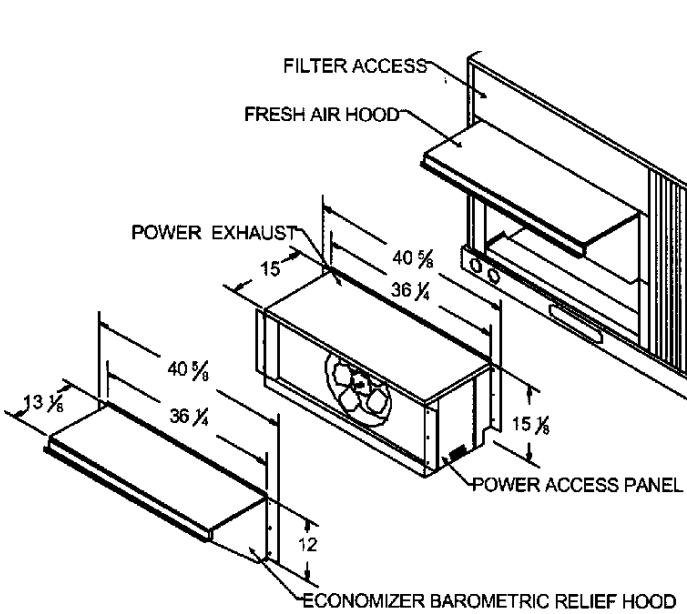

POWER EXHAUST DOWNFLOW, MODEL AXB145***

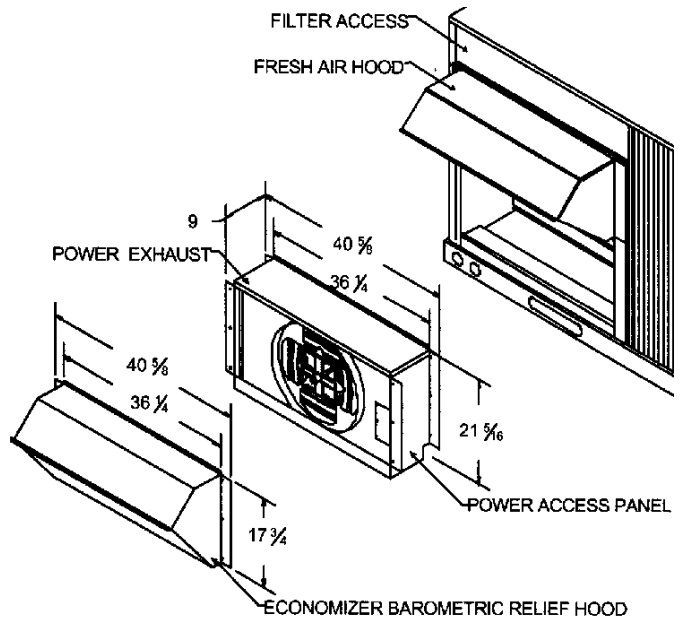

POWER EXHAUST DOWNFLOW, MODEL AXB245***

CONTROLS

OPERATING SEQUENCE

Cooling, Units Without Economizer When thermostat calls for cooling, terminals G and Y1 are energized. The indoor (evaporator) fan contactor (IFC), compressor contactor no. 1 (C1) and outdoor-fan contactor (OFC) are energized, and evaporator-fan motor, compressor no. 1, and both condenser fans start. The condenser-fan motors run continuously while unit is cooling. If the thermostat calls for a second stage of cooling by energizing Y2, compressor contactor no. 2 (C2) is energized and compressor no. 2 starts.

When the thermostat is satisfied, C1 and C2 are deenergized and the compressors and outdoor (condenser) fan motors (OFM) shut off. After a 30-second delay, the indoor (evaporator) fan motor (IFM) shuts off. If the thermostat fan selector switch is in the ON position, the evaporator-fan motor will run continuously.

Heating, Units Without Economizer When the thermostat calls for heating, terminal W1 is energized. In order to prevent thermostat short-cycling, the unit is locked into the Heating mode for at least 1 minute when W1 is energized. The induced-draft motor (IDM) is then energized and the burner ignition sequence begins. The indoor (evaporator) fan motor (IFM) is energized 45 seconds after a flame is ignited. On units equipped for two stages of heat, when additional heat is needed, W2 is energized and the high-fire solenoid on the main gas valve (MGV) is energized. When the thermostat is satisfied and W1 and W2 are deenergized, the IFM stops after a 45-second time-off delay.

APPLICATION DATA

- 1. DUCTWORK** Secure vertical discharge ductwork to roof curb. For horizontal discharge applications, attach ductwork to unit, or field-supplied flanges can be attached to horizontal discharge openings and all ductwork attached to flanges.
- 2. THRU-THE-BOTTOM UTILITY CONNECTIONS** An accessory kit is required for proper installation of thru-the-bottom connections.
- 3. THERMOSTAT** Use of 2-stage cooling thermostat is recommended for all units.
- 4. HEATING-TO-COOLING CHANGEOVER** All units are automatic changeover from heating to cooling when automatic changeover thermostat and subbase are used.
- 5. AIRFLOW** Units are draw-thru on cooling and blow-thru on heating.
- 6. MAXIMUM AIRFLOW** To minimize the possibility of condensate blow-off from evaporator, airflow through units should not exceed 500 cfm/ton.
- 7. MINIMUM AIRFLOW** The minimum airflow for cooling is 300 cfm/ton.
- 8. MINIMUM AMBIENT COOLING OPERATION TEMPERATURE** The cooling temperature for size all units is 25°F.
- 9. MAXIMUM OPERATING OUTDOOR-AIR TEMPERATURE** For cooling, this temperature is 115°F.
- 10. HIGH ALTITUDE** A change to the gas orifice may be required at high altitudes. Refer to Altitude Compensation charts.

11. MINIMUM TEMPERATURE Air entering the heat exchanger in heating must be a minimum of 50°F continuous and 45°F intermittent.

12. INTERNAL UNIT DESIGN Due to the PGS internal unit design (draw-thru over the motor), air path, and specially designed motors, the full horsepower (maximum continuous bhp) listed in the Physical Data table and the notes following each Fan Performance table can be utilized with extreme confidence.

Using PGS motors with the values listed in the Physical and Fan Performance Data tables will not result in nuisance tripping or premature motor failure. The unit warranty will not be affected.

GUIDE SPECIFICATIONS: PGS072-150

CABINET:

The cabinet shall be made of sturdy baked enamel coated galvanized steel. Base rails shall be 16 gauge steel and have fork lift slots and holes provided for lifting shackles. Unit shall be designed with convertible airflow and shipped ready for downflow applications with conversion to horizontal air flow accomplished by relocating two panels.

Return air compartments shall be insulated with not less than 1/2" of water resistant coated glass fiber and not less than 1/2" of aluminum foil faced glass fiber in the furnace/supply compartments.

COOLING SECTION:

Units shall be factory charged and operationally ready. Each refrigeration circuit shall have a compressor, with internal overload protection, high and low pressure switches, filter drier and copper tube/aluminum fin evaporator and condenser coils.

Units shall be capable of cooling operation down to 25°F as shipped from the factory.

COILS:

The evaporator and condenser coils shall be fabricated with aluminum fins mechanically bonded to copper tubing. Both coils shall be pressure tested prior to assembly into the unit and electronically leak tested after assembly onto the unit. The evaporator coil shall be protected from dust and debris on the return air side by factory installed 2" air filters.

CONDENSER FAN:

The unit shall have a single direct drive propeller fan/motor assembly mounted directly to a vertical-discharge grille panel that is easily removable. Motors shall have permanently lubricated sleeve bearings and inherent overload protection.

EVAPORATOR BLOWER:

The units shall have a single belt driven evaporator blower. The motor shall have permanently lubricated ball bearings and internal overload protection. An adjustable motor drive sheave for matching air flow requirements shall be standard.

HEATING SECTION:

The units shall have aluminized steel tubular heat exchangers located on the discharge side of the evaporator blower and equipped with a two-stage gas valve. The units shall have in-shot burners that are ignited by an electronic spark with flame proving feature and protected by both a limit switch and flame roll-out switch.