

13 SEER R-410A PACKAGE AIR CONDITIONER UNIT (1 Ph.) 2 - 5 TONS

REFRIGERATION CIRCUIT

- All models are equipped with high efficiency two-stage Copeland scroll compressor.
- Thermostatic Expansion Valve (TXV) on select models to control refrigerant flow.
- High Efficiency Brushless DC indoor motors on all models.
- High and Low pressure switches for excellent compressor protection.

BUILT TO LAST

- Galvanized-painted cabinet. One piece weather resistant top. Access panels for easy service. Side by side supply and return. Heavy gauge base rails.
- Triple-coated steel, consisting of a polyester top coat, a urethane primer coat preceded by an oxide pretreatment.
- Integral base rails with fork-lift access. Holes provided for lifting lugs makes rooftop installation easier.
- The condenser coil has a sturdy wire inlet grille and UV rated vinyl mesh installed on the surface of the coil for additional protection.
- Advanced Air Management System for quieter operation.

EASY TO INSTALL AND SERVICE

- Combination electric cooling and electric heat, self contained for year-round comfort. Systems installed on rooftop or ground level. The unit is shipped in the horizontal position and can easily be converted to downflow.
- Externally-mounted gauge ports allow for more accurate reading of operating conditions while servicing.
- Electrical controls located behind one exterior panel for easier maintenance.

ELECTRIC HEAT

- Slip in electrical heat from 5 to 20 kW.

WARRANTY

- 5 year No Hassle replacement limited warranty
- 10 year compressor limited warranty
- 5 year parts limited warranty



UNIT PERFORMANCE DATA

Model Number	COOLING		Voltage-Phase-Hz	Unit Dimensions H x W x L	Ship Weight
	Rated Capacity BTUH	S.E.E.R			
PAX324000K00A	22,800	13.5	208/230-1-60	32-1/2 X 47-5/16 X 47-5/16	406
PAX330000K00A	28,000	13.5	208/230-1-60	32-1/2 X 47-5/16 X 47-5/16	358
PAX336000K00A	34,600	13.5	208/230-1-60	32-1/2 X 47-5/16 X 47-5/16	415
PAX342000K00A	40,000	13.0	208/230-1-60	36 X 47-5/16 X 73	529
PAX348000K00A	45,000	13.5	208/230-1-60	36 X 47-5/16 X 73	529
PAX360000K00A	57,000	13.5	208/230-1-60	36 X 47-5/16 X 73	590

UNIT SPECIFICATIONS

MODEL * NUMBER	Electrical Data			Condenser Data									Sound Ratings (db)
				Coil			Fan Motor			Fan			
	208 / 230 Voltage Phase - Hz	HACR Brkr Max Fuse	Minimum Circuit Ampacity	Total Face Area (Sq. Ft.)	Fins Per In. / Rows	Tube Diameter (In.)	HP	Full Load Amps	Locked Rotor Amps	Size Diameter (In.)	RPM (Max.)	CFM (Design)	
PAX324000K00A	1-60	25 amps.	17.8	11.40	18 / 2	3/8	1/8	0.9	1.6	20	825	2200	72
PAX330000K00A	1-60	35 amps.	22.6	11.46	18 / 2	3/8	1/8	0.9	1.6	20	825	2200	73
PAX336000K00A	1-60	40 amps.	28.2	11.40	18 / 2	3/8	1/4	1.4	3.7	20	1100	2200	75
PAX342000K00A	1-60	40 amps.	28.9	12.99	18 / 2	3/8	1/4	1.4	3.7	22	1100	2200	77
PAX348000K00A	1-60	50 amps.	35.5	12.99	18 / 2	3/8	1/4	1.4	3.7	22	1100	2400	77
PAX360000K00A	1-60	60 amps.	41.2	17.12	18 / 2	3/8	1/4	1.4	3.0	22	1100	3000	78

MODEL NUMBER	Evaporator Coil									Scroll Compressor		Factory Refrigerant Charge R410A (lbs.)	Ship Weight (Lbs.)
	Coil			Motor			Blower			Rated Load Amps	Locked Rotor Amps		
	Total Face Area (Sq. Ft.)	Fins Per In. / Rows	Tube Diam. (In.)	Horse Power	Full Load Amps	No. of Speed Taps	Size	RPM (Max)	CFM Rated				
PAX324000K00A	3.56	14 / 4	3/8	1/2	4.1	5	10 x 8	1050	800	10.3	52.0	10.3	390
PAX330000K00A	3.56	14 / 3	3/8	1/2	4.1	5	10 x 8	1050	1000	14.1	70.0	8.1	402
PAX336000K00A	3.56	14 / 4	3/8	3/4	6.0	4	11 x 9	1050	1200	16.7	82.0	10.2	449
PAX342000K00A	5.14	14 / 3	3/8	3/4	6.0	5	11 x 9	1050	1400	17.2	96.0	12.7	570
PAX348000K00A	5.14	14 / 3	3/8	1.0	7.7	5	11 x 10	1050	1600	21.2	96.0	11.8	640
PAX360000K00A	8.22	14 / 3	3/8	1.0	7.7	5	11 x 10	1050	2000	25.6	118.0	15.00	646

PERFORMANCE DATA: COOLING

MODEL NUMBER	Rated Capacity ¹ BTUH	S / T Ratio	S.E.E.R.	E.E.R.	Power Input Watts	Evaporator Rated ² Airflow (SCFM)
PAX324000K00A	22,800	.76	13.5	10.5	2090	800
PAX330000K00A	28,000	.79	13.5	10.5	2600	1000
PAX336000K00A	34,600	.76	13.5	10.0	3182	1200
PAX342000K00A	40,000	.76	13.0	10.0	3636	1400
PAX348000K00A	45,000	.76	13.5	10.2	4363	1600
PAX360000K00A	57,000	.76	13.5	10.0	5510	1875

1. Rated Capacity @ ARI standard conditions, 95° Amb, 80° DB/67° WB, 230 Volts. For applications at 208 volts deduct 1000 BTUH.

2. Includes a 0.08 drop for filter.

ELECTRIC HEATER USAGE CHART

EHBA Heater Model No's (Example: EHBA05KN)								
Without Circuit Breakers	05KN		07KN		10KN			
With Circuit Breakers		05KB		07KB		10KB	15KB	20KB
Unit kW	5kW		7.5kW		10kW		15kW	20kW
PAX3	USED ON							
24	X	X	X	X	X	X		
30	X	X	X	X	X	X	X	
36	X	X	X	X		X	X	X
42	X	X	X	X		X	X	X
48	X	X	X	X		X	X	X
60	X	X	X	X		X	X	X

PAX3 - ELECTRICAL DATA: ELECTRIC HEAT ACCESSORY

Heater Model	Used With	Supply Voltage	KW Rating	Nominal Heating BTUH	Supply Circuit No.	Heater Amps	Minimum Circuit Ampacity	Max. Overcurrent Protective Device (Amps)
EHBA05KB EHBA05KN	2 to 5 Ton	240-1-60	5.0	17,065	L3 - L4	20.8	26.0	30
		208-1-60	3.75	12,798	L3 - L4	18.0	22.5	25
EHBA07KB EHBA07KN	2 to 5 Ton	240-1-60	7.5	25,598	L3-L4	31.3	39.1	40
		208-1-60	5.6	19,113	L3-L4	27.1	33.9	35
EHBA10KB	2 to 5 Ton	240-1-60	10.0	34,130	L3 - L4	41.7	52.1	60
		208-1-60	7.5	25,598	L3 - L4	36.2	45.3	45
EHBA10KN	2 to 2-1/2 Ton	240-1-60	10.0	34,130	L3 - L4	41.7	52.1	60
		208-1-60	7.5	25,598	L3 - L4	36.2	45.3	45
EHBA15KB	2-1/2 to 5 Ton	240-1-60	15.0	51,195	L3 - L4	41.7	52.1	60
					L5 - L6	20.8	26.0	30
		208-1-60	11.25	38,567	L3 - L4	36.2	45.3	45
					L5 - L6	18.0	22.5	25
EHBA20KB	3 to 5 Ton	240-1-60	20	68,260	L3 - L4	41.7	52.1	60
					L5 - L6	41.7	52.1	60
		208-1-60	15.0	51,195	L3 - L4	36.2	45.3	45
					L5 - L6	36.2	45.3	45

PAX3 - PERFORMANCE DATA: ELECTRIC HEAT ACCESSORY

Heater Model	Use With	Supply Voltage	KW Rating	Total Heating BTUH	*Temperature Rise °F @ CFM								
					600	800	1000	1200	1400	1600	1800	2000	2200
EHBA05KB EHBA05KN	2 to 5 Ton	240-1-60	5.0	17,065	26.4	19.8	15.8	13.1	11.2	9.9	8.7	7.9	-
		208-1-60	3.75	12,798	19.8	14.8	11.9	9.9	8.4	7.4	6.6	5.9	-
EHBA07KB EHBA07KN	2 to 5 Ton	240-1-60	7.5	25,598	39.5	29.6	23.7	19.8	16.9	14.8	13.2	11.9	10.8
		208-1-60	5.6	19,113	29.5	22.1	17.7	14.7	12.6	11.1	9.8	8.8	8.0
EHBA10KB	2 to 5 Ton	240-1-60	10.0	34,130	52.7	39.5	31.6	26.4	22.6	19.8	17.6	15.8	14.4
		208-1-60	7.5	25,598	39.5	29.6	23.7	19.8	17.0	14.8	13.1	11.9	10.7
EHBA10KN	2 to 2-1/2 Ton	240-1-60	10.0	34,130	52.7	39.5	31.6	26.4	22.6	19.8	17.6	15.8	14.4
		208-1-60	7.5	25,598	39.5	29.6	23.7	19.8	17.0	14.8	13.1	11.9	10.7
EHBA15KB	2-1/2 to 5 Ton	240-1-60	15.0	51,195	-	59.3	47.4	39.5	33.9	29.6	26.4	23.7	21.2
		208-1-60	11.25	38,567	59.3	44.5	35.5	27.3	25.4	22.2	19.8	17.8	16.1
EHBA20KB	3 to 5 Ton	240-1-60	20.0	68,260	-	-	-	52.7	45.1	39.5	35.1	31.6	28.7
		208-1-60	15.0	51,195	-	59.3	47.4	39.5	33.9	29.6	26.4	23.7	21.2

BLOWER PERFORMANCE DATA

Model Number		PAX324					PAX330					PAX336				
Torque (oz.-Ft.)		5.96	10.98	15.53	18.04	29.02	11.92	13.02	18.04	23.06	29.02	18.59	24.00	34.35	52.94	-
Speed Tap		1	2	3	4	5	1	2	3	4	5	1	2	3	4	5
Air Delivery in CFM @ Varying External Static Pressure (in. w.c.)	0.1	661	711	869	951	1251	754	789	958	1106	1255	876	1026	1276	1630	-
	0.2	478	655	842	914	1218	708	747	923	1080	1227	841	994	1242	1588	-
	0.3	334	623	809	883	1194	671	714	894	1048	1201	794	949	1209	1526	-
	0.4	262	564	768	858	1170	618	668	857	1017	1164	756	913	1179	1477	-
	0.5	219	529	736	811	1139	584	630	828	992	1138	694	871	1150	1415	-
	0.6	196	481	684	775	1100	524	582	786	954	1112	651	841	1117	1354	-
	0.7	-	431	650	733	1063	494	542	750	924	1077	598	793	1086	1287	-
	0.8	-	392	599	697	988	443	495	712	881	1027	543	735	1045	1216	-
	0.9	-	334	569	658	871	382	460	661	838	934	499	683	998	1145	-
	1	-	305	523	618	745	342	403	630	755	809	464	638	946	1070	-
Model Number		PAX342					PAX348					PAX360				
Torque (oz.-Ft.)		19.06	23.06	34.12	41.88	44.00	26.98	32.00	51.14	59.92	80.00	30.12	31.06	55.84	73.10	80.00
Speed Tap		1	2	3	4	5	1	2	3	4	5	1	2	3	4	5
Air Delivery in CFM @ Varying External Static Pressure (in. w.c.)	0.1	973	1028	1302	1481	1569	1173	1304	1680	1831	2103	1300	1368	1839	2091	2188
	0.2	900	969	1260	1448	1537	1127	1256	1650	1797	2051	1263	1321	1807	2056	2140
	0.3	853	924	1219	1412	1500	1085	1216	1614	1763	2001	1214	1283	1772	2023	2096
	0.4	797	881	1179	1374	1463	1027	1167	1578	1732	1942	1169	1231	1735	1987	2039
	0.5	749	838	1138	1336	1423	983	1126	1544	1696	1878	1117	1197	1702	1935	1974
	0.6	702	789	1103	1298	1389	927	1077	1507	1661	1809	1073	1144	1667	1878	1905
	0.7	642	731	1060	1263	1353	881	1026	1470	1621	1723	1026	1105	1629	1811	1827
	0.8	581	680	1015	1226	1317	821	979	1427	1559	1632	975	1038	1590	1729	1745
	0.9	529	617	963	1186	1276	764	921	1373	1446	1526	926	969	1535	1640	1642
	1	476	562	923	1143	1208	710	875	1289	1339	1388	862	913	1460	1536	1537

Notes:

Air Delivery @ listed external static pressure are taken at 230Volts with Dry coil, no filter and approved heater.
 For wet coil add .05 in. wc. to Static Pressure measurement. Note for 208 Volts applications, reduce airflow by 15%.

	Blower Speed Tap Settings		
	Low Capacity Airflow	Rated Airflow	High Capacity Airflow
PAX324	Speed Tap 1	Speed Tap 3	Speed Tap 5
PAX330	Speed Tap 1	Speed Tap 4	Speed Tap 5
PAX336	Speed Tap 1	Speed Tap 3	Speed Tap 5
PAX342	Speed Tap 1	Speed Tap 4	Speed Tap 5
PAX348	Speed Tap 1	Speed Tap 3	Speed Tap 5
PAX360	Speed Tap 1	Speed Tap 3	Speed Tap 5

EXPANDED PERFORMANCE DATA: COOLING

PAX324*K**A**

OD Ambient (°F)	ID Airflow (SCFM)	700					800					900				
		Entering Indoor Temperature - Degrees F, Wet Bulb														
		57	62	63 ⁺⁺	67	72	57	62	63 ⁺⁺	67	72	57	62	63 ⁺⁺	67	72
75	MBh ⁺	23.5	24.3	24.7	26.7	29.2	24.6	25.0	25.4	27.3	29.9	25.6	25.7	25.9	27.9	30.5
	S/T	0.98	0.91	0.73	0.70	0.51	0.98	0.96	0.76	0.73	0.53	0.98	0.98	0.79	0.77	0.55
	kW*	1.36	1.37	1.37	1.39	1.41	1.39	1.40	1.40	1.42	1.44	1.42	1.42	1.42	1.44	1.46
85	MBh ⁺	22.7	23.3	23.7	25.5	28.0	23.7	23.9	24.3	26.1	28.6	24.7	24.7	24.7	26.6	29.1
	S/T	0.98	0.93	0.74	0.71	0.52	0.98	0.98	0.77	0.75	0.54	0.98	0.98	0.81	0.78	0.56
	kW*	1.52	1.53	1.53	1.55	1.57	1.55	1.55	1.55	1.57	1.59	1.58	1.58	1.58	1.60	1.62
95	MBh ⁺	21.8	22.2	22.5	24.3	26.6	22.8	22.8	23.1	24.8	27.2	23.7	23.7	23.5	25.3	27.6
	S/T	0.98	0.96	0.76	0.73	0.53	0.98	0.98	0.79	0.77	0.55	0.98	0.98	0.83	0.80	0.57
	kW*	1.70	1.70	1.70	1.72	1.74	1.72	1.73	1.73	1.74	1.77	1.75	1.75	1.75	1.77	1.79
105	MBh ⁺	20.8	21.0	21.3	23.0	25.2	21.8	21.8	21.8	23.5	25.7	22.6	22.6	22.2	23.9	26.1
	S/T	0.98	0.98	0.77	0.75	0.54	0.98	0.98	0.81	0.79	0.56	0.98	0.98	0.85	0.83	0.58
	kW*	1.89	1.89	1.89	1.91	1.93	1.92	1.92	1.92	1.93	1.95	1.94	1.94	1.94	1.96	1.98
115	MBh ⁺	19.8	19.9	20.0	21.6	23.7	20.7	20.7	20.5	22.1	24.1	21.4	21.5	20.8	22.4	24.5
	S/T	0.98	0.98	0.79	0.77	0.55	0.98	0.98	0.84	0.81	0.57	0.98	0.98	0.88	0.86	0.60
	kW*	2.10	2.10	2.10	2.12	2.14	2.13	2.13	2.13	2.14	2.16	2.15	2.15	2.15	2.16	2.18
125	MBh ⁺	18.7	18.7	18.6	20.1	22.0	19.5	19.5	19.0	20.5	22.3	20.1	20.2	19.3	20.8	22.6
	S/T	0.98	0.98	0.82	0.80	0.56	0.98	0.98	0.87	0.85	0.59	0.98	0.98	0.92	0.90	0.62
	kW*	2.33	2.33	2.33	2.34	2.36	2.36	2.36	2.35	2.37	2.39	2.38	2.38	2.37	2.39	2.41

PAX324*K**A (Low Capacity)**

OD Ambient (°F)	ID Airflow (SCFM)	475					550					625				
		Entering Indoor Temperature - Degrees F, Wet Bulb														
		57	62	63 ⁺⁺	67	72	57	62	63 ⁺⁺	67	72	57	62	63 ⁺⁺	67	72
75	MBh ⁺	17.3	18.3	18.6	20.3	22.4	18.4	19.0	19.3	21.0	23.2	19.3	19.5	19.8	21.5	23.8
	S/T	0.98	0.88	0.71	0.68	0.50	0.98	0.93	0.74	0.71	0.52	0.98	0.97	0.77	0.74	0.53
	kW*	0.93	0.93	0.92	0.91	0.89	0.93	0.93	0.92	0.91	0.89	0.96	0.96	0.95	0.94	0.92
85	MBh ⁺	16.6	17.3	17.7	19.3	21.3	17.6	18.0	18.3	19.9	22.0	18.5	18.5	18.8	20.4	22.6
	S/T	0.98	0.90	0.72	0.69	0.51	0.98	0.95	0.75	0.72	0.52	0.98	0.98	0.79	0.76	0.54
	kW*	1.10	1.09	1.09	1.08	1.07	1.10	1.10	1.09	1.08	1.06	1.13	1.13	1.13	1.11	1.09
95	MBh ⁺	15.9	16.4	16.8	18.2	20.3	16.8	17.0	17.3	18.8	20.9	17.7	17.7	17.7	19.3	21.3
	S/T	0.98	0.92	0.73	0.70	0.52	0.98	0.98	0.77	0.74	0.53	0.98	0.98	0.81	0.78	0.55
	kW*	1.29	1.28	1.28	1.27	1.26	1.29	1.29	1.28	1.27	1.26	1.32	1.32	1.32	1.31	1.29
105	MBh ⁺	15.2	15.5	15.8	17.2	19.1	16.1	16.1	16.3	17.8	19.7	16.8	16.9	16.7	18.2	20.1
	S/T	0.98	0.95	0.75	0.72	0.52	0.98	0.98	0.79	0.76	0.54	0.98	0.98	0.83	0.80	0.57
	kW*	1.49	1.49	1.49	1.49	1.48	1.50	1.50	1.50	1.49	1.48	1.53	1.53	1.53	1.52	1.51
115	MBh ⁺	14.4	14.6	14.8	16.2	18.0	15.3	15.3	15.3	16.7	18.5	16.0	16.0	15.6	17.0	18.9
	S/T	0.98	0.98	0.77	0.74	0.53	0.98	0.98	0.82	0.79	0.56	0.98	0.98	0.86	0.83	0.58
	kW*	1.73	1.73	1.73	1.73	1.72	1.73	1.73	1.73	1.73	1.72	1.77	1.77	1.77	1.76	1.75
125	MBh ⁺	13.6	13.7	13.8	15.1	16.8	14.4	14.4	14.2	15.5	17.2	15.1	15.1	14.5	15.8	17.5
	S/T	0.98	0.98	0.80	0.77	0.55	0.98	0.98	0.85	0.81	0.57	0.98	0.98	0.89	0.86	0.60
	kW*	1.99	1.99	1.99	1.99	1.99	2.00	2.00	2.00	2.00	1.99	2.03	2.03	2.03	2.03	2.03

Notes: When the required data fall between the published data, interpolation may be performed. Extrapolation is not an acceptable practice.

+Total capacities are net capacities. Blower heat has been subtracted.

++ At TVA rating indoor condition (75 F db/ 63 F wb), All other indoor air temperatures are at 80 F db

* System kW is total unit kW

Standard Rating =

S/T are based on 80°F db entering air at the indoor coil. For sensible capacities at other than 80°5 db, deduct 83° Btuh per 1000 cfm of indoor coil air from (MBh x S/T) for each degree below 80°F, or add 835 Btuh per 1000 cfm of indoor coil air from (MBh x S/T) for each degree above 80°F.

EXPANDED PERFORMANCE DATA: COOLING

PAX330*K**A**

OD Ambient (°F)	ID Airflow (SCFM)	875					1000					1125				
		Entering Indoor Temperature - Degrees F, Wet Bulb														
		57	62	63 ⁺⁺	67	72	57	62	63 ⁺⁺	67	72	57	62	63 ⁺⁺	67	72
75	MBh ⁺	28.7	29.7	30.2	32.5	35.5	30.1	30.5	31.0	33.3	36.3	31.2	31.3	31.6	33.9	36.9
	S/T	0.98	0.91	0.73	0.70	0.51	0.98	0.96	0.76	0.73	0.53	0.98	0.98	0.79	0.77	0.55
	kW*	1.78	1.78	1.79	1.81	1.84	1.84	1.84	1.85	1.87	1.90	1.89	1.89	1.89	1.92	1.95
85	MBh ⁺	27.7	28.4	28.9	31.0	33.9	29.0	29.2	29.6	31.8	34.6	30.0	30.1	30.1	32.3	35.2
	S/T	0.98	0.93	0.74	0.71	0.52	0.98	0.98	0.77	0.75	0.54	0.98	0.98	0.81	0.79	0.56
	kW*	1.97	1.98	1.98	2.01	2.04	2.03	2.04	2.04	2.06	2.09	2.08	2.08	2.08	2.11	2.14
95	MBh ⁺	26.6	27.1	27.5	29.5	32.2	27.8	27.8	28.1	30.2	32.9	28.8	28.8	28.6	30.7	33.4
	S/T	0.98	0.95	0.75	0.73	0.53	0.98	0.98	0.79	0.77	0.55	0.98	0.98	0.83	0.81	0.57
	kW*	2.19	2.19	2.19	2.22	2.25	2.25	2.25	2.25	2.27	2.30	2.30	2.30	2.30	2.32	2.35
105	MBh ⁺	25.4	25.6	26.0	27.9	30.4	26.5	26.6	26.5	28.5	31.0	27.4	27.5	27.0	28.9	31.5
	S/T	0.98	0.98	0.77	0.75	0.54	0.98	0.98	0.81	0.79	0.56	0.98	0.98	0.85	0.83	0.58
	kW*	2.42	2.42	2.43	2.45	2.48	2.48	2.48	2.48	2.50	2.53	2.53	2.53	2.53	2.55	2.58
115	MBh ⁺	24.2	24.2	24.4	26.2	28.5	25.1	25.2	24.9	26.7	29.0	26.0	26.0	25.3	27.1	29.4
	S/T	0.98	0.98	0.79	0.77	0.55	0.98	0.98	0.84	0.82	0.57	0.98	0.98	0.88	0.86	0.60
	kW*	2.68	2.68	2.68	2.70	2.73	2.74	2.74	2.73	2.76	2.79	2.79	2.79	2.78	2.80	2.83
125	MBh ⁺	22.7	22.7	22.6	24.2	26.4	23.6	23.6	23.0	24.7	26.8	24.3	24.3	23.4	25.0	27.1
	S/T	0.98	0.98	0.82	0.80	0.56	0.98	0.98	0.87	0.85	0.59	0.98	0.98	0.92	0.90	0.62
	kW*	2.95	2.95	2.95	2.97	3.00	3.01	3.02	3.01	3.03	3.06	3.06	3.06	3.05	3.07	3.10

PAX330*K**A (Low Capacity)**

OD Ambient (°F)	ID Airflow (SCFM)	600					700					800				
		Entering Indoor Temperature - Degrees F, Wet Bulb														
		57	62	63 ⁺⁺	67	72	57	62	63 ⁺⁺	67	72	57	62	63 ⁺⁺	67	72
75	MBh ⁺	21.3	22.3	22.7	24.5	26.9	22.6	23.1	23.5	25.3	27.7	23.6	23.8	24.0	25.9	28.4
	S/T	0.98	0.89	0.71	0.69	0.51	0.98	0.94	0.75	0.72	0.53	0.98	0.99	0.78	0.76	0.54
	kW*	1.16	1.16	1.16	1.17	1.17	1.16	1.16	1.16	1.17	1.17	1.21	1.22	1.22	1.22	1.23
85	MBh ⁺	20.5	21.2	21.6	23.4	25.7	21.7	22.0	22.3	24.1	26.4	22.7	22.7	22.8	24.6	27.0
	S/T	0.98	0.91	0.73	0.70	0.51	0.98	0.97	0.76	0.74	0.53	0.98	0.98	0.80	0.78	0.55
	kW*	1.37	1.37	1.37	1.38	1.38	1.37	1.37	1.37	1.38	1.38	1.42	1.42	1.42	1.43	1.43
95	MBh ⁺	19.6	20.1	20.5	22.1	24.3	20.7	20.8	21.1	22.8	25.0	21.7	21.7	21.6	23.3	25.5
	S/T	0.98	0.94	0.74	0.71	0.52	0.98	0.99	0.78	0.76	0.54	0.98	0.98	0.82	0.80	0.57
	kW*	1.59	1.59	1.60	1.60	1.61	1.60	1.60	1.60	1.60	1.61	1.65	1.65	1.65	1.66	1.66
105	MBh ⁺	18.7	19.0	19.3	20.8	22.9	19.7	19.7	19.8	21.4	23.5	20.6	20.6	20.2	21.8	23.9
	S/T	0.98	0.96	0.76	0.73	0.53	0.98	0.98	0.81	0.78	0.55	0.98	0.98	0.85	0.82	0.58
	kW*	1.84	1.84	1.84	1.85	1.86	1.84	1.84	1.84	1.85	1.86	1.90	1.90	1.90	1.90	1.91
115	MBh ⁺	17.7	17.7	18.0	19.4	21.4	18.6	18.7	18.5	19.9	21.9	19.4	19.4	18.8	20.3	22.2
	S/T	0.98	0.98	0.78	0.76	0.54	0.98	0.98	0.83	0.81	0.57	0.98	0.98	0.88	0.86	0.60
	kW*	2.11	2.11	2.11	2.12	2.13	2.11	2.11	2.11	2.12	2.13	2.17	2.17	2.16	2.17	2.18
125	MBh ⁺	16.6	16.6	16.6	17.9	19.7	17.4	17.4	17.0	18.4	20.1	18.1	18.1	17.3	18.7	20.4
	S/T	0.98	0.98	0.82	0.79	0.56	0.98	0.98	0.87	0.84	0.59	0.98	0.98	0.92	0.90	0.62
	kW*	2.39	2.39	2.39	2.40	2.42	2.40	2.40	2.40	2.41	2.42	2.45	2.45	2.45	2.46	2.47

Notes: When the required data fall between the published data, interpolation may be performed. Extrapolation is not an acceptable practice.

+Total capacities are net capacities. Blower heat has been subtracted.

++ At TVA rating indoor condition (75 F db/ 63 F wb), All other indoor air temperatures are at 80 F db

* System kW is total unit kW

Standard Rating =

S/T are based on 80°F db entering air at the indoor coil. For sensible capacities at other than 80°5 db, deduct 83° Btuh per 1000 cfm of indoor coil air from (MBh x S/T) for each degree below 80°F, or add 835 Btuh per 1000 cfm of indoor coil air from (MBh x S/T) for each degree above 80°F.

EXPANDED PERFORMANCE DATA: COOLING

PAX336*K**A**

OD Ambient (°F)	ID Airflow (SCFM)	1030					1200					1350				
		Entering Indoor Temperature - Degrees F, Wet Bulb														
		57	62	63 ⁺⁺	67	72	57	62	63 ⁺⁺	67	72	57	62	63 ⁺⁺	67	72
75	MBh ⁺	35.8	37.2	37.9	41.0	45.1	37.6	38.3	38.9	42.0	46.2	39.1	39.3	39.7	42.9	47.1
	S/T	0.98	0.91	0.72	0.69	0.51	0.98	0.95	0.75	0.73	0.52	0.98	0.99	0.79	0.76	0.54
	kW*	2.40	2.41	2.42	2.44	2.47	2.56	2.57	2.58	2.60	2.63	2.73	2.73	2.73	2.76	2.79
85	MBh ⁺	34.4	35.4	36.0	39.0	43.0	36.1	36.5	36.9	39.9	44.0	37.5	37.6	37.7	40.7	44.8
	S/T	0.98	0.93	0.74	0.71	0.51	0.98	0.98	0.77	0.74	0.53	0.98	0.98	0.81	0.78	0.55
	kW*	2.69	2.70	2.70	2.73	2.76	2.85	2.85	2.86	2.89	2.92	3.01	3.01	3.01	3.04	3.08
95	MBh ⁺	33.0	33.6	34.1	36.9	40.7	34.5	34.6	34.9	37.8	41.7	35.9	35.9	35.6	38.5	42.4
	S/T	0.98	0.96	0.75	0.73	0.52	0.98	0.98	0.79	0.76	0.54	0.98	0.98	0.83	0.80	0.56
	kW*	2.99	3.00	3.01	3.04	3.07	3.16	3.16	3.17	3.19	3.23	3.32	3.32	3.32	3.35	3.39
105	MBh ⁺	31.4	31.7	32.1	34.8	38.4	32.9	32.9	32.9	35.6	39.3	34.1	34.2	33.5	36.3	39.9
	S/T	0.98	0.98	0.77	0.74	0.53	0.98	0.98	0.81	0.79	0.55	0.98	0.98	0.85	0.83	0.57
	kW*	3.33	3.33	3.34	3.37	3.41	3.50	3.50	3.50	3.53	3.57	3.66	3.66	3.65	3.68	3.72
115	MBh ⁺	29.8	29.8	30.0	32.6	36.0	31.1	31.2	30.7	33.3	36.8	32.3	32.3	31.2	33.9	37.3
	S/T	0.98	0.98	0.80	0.77	0.54	0.98	0.98	0.84	0.81	0.57	0.98	0.98	0.88	0.86	0.59
	kW*	3.69	3.69	3.70	3.73	3.77	3.86	3.86	3.85	3.89	3.93	4.02	4.02	4.01	4.04	4.08
125	MBh ⁺	28.0	28.1	27.8	30.2	33.5	29.3	29.3	28.4	30.9	34.1	30.3	30.4	28.9	31.4	34.6
	S/T	0.98	0.98	0.83	0.80	0.56	0.98	0.98	0.87	0.85	0.58	0.98	0.98	0.92	0.89	0.61
	kW*	4.08	4.08	4.08	4.11	4.15	4.25	4.25	4.23	4.27	4.31	4.41	4.41	4.39	4.43	4.47

PAX336*K**A (Low Capacity)**

OD Ambient (°F)	ID Airflow (SCFM)	750					850					950				
		Entering Indoor Temperature - Degrees F, Wet Bulb														
		57	62	63 ⁺⁺	67	72	57	62	63 ⁺⁺	67	72	57	62	63 ⁺⁺	67	72
75	MBh ⁺	25.2	26.0	26.5	28.8	31.9	26.4	26.8	27.2	29.5	32.7	27.5	27.6	27.8	30.2	33.3
	S/T	0.98	0.92	0.73	0.71	0.51	0.98	0.97	0.77	0.74	0.53	0.98	0.98	0.80	0.77	0.55
	kW*	1.23	1.19	1.17	1.07	0.94	1.20	1.18	1.17	1.07	0.93	1.18	1.17	1.17	1.06	0.92
85	MBh ⁺	24.1	24.6	25.0	27.2	30.2	25.2	25.3	25.6	27.9	30.9	26.2	26.3	26.2	28.4	31.5
	S/T	0.98	0.95	0.75	0.72	0.52	0.98	0.99	0.79	0.76	0.54	0.98	0.98	0.82	0.79	0.56
	kW*	1.48	1.46	1.44	1.34	1.22	1.45	1.45	1.44	1.34	1.21	1.44	1.43	1.44	1.34	1.21
95	MBh ⁺	22.9	23.1	23.5	25.6	28.4	24.0	24.0	24.1	26.2	29.1	24.9	25.0	24.5	26.7	29.6
	S/T	0.98	0.98	0.77	0.74	0.53	0.98	0.98	0.81	0.78	0.55	0.98	0.98	0.84	0.82	0.57
	kW*	1.75	1.74	1.73	1.64	1.51	1.73	1.73	1.73	1.64	1.51	1.72	1.72	1.73	1.64	1.51
105	MBh ⁺	21.7	21.8	22.0	24.0	26.6	22.7	22.8	22.5	24.5	27.2	23.6	23.6	22.9	24.9	27.7
	S/T	0.98	0.98	0.80	0.77	0.54	0.98	0.98	0.84	0.81	0.56	0.98	0.98	0.87	0.85	0.59
	kW*	2.05	2.05	2.04	1.96	1.84	2.03	2.03	2.05	1.96	1.84	2.02	2.02	2.05	1.96	1.84
115	MBh ⁺	20.5	20.5	20.4	22.3	24.8	21.4	21.4	20.8	22.7	25.3	22.2	22.2	21.2	23.1	25.7
	S/T	0.98	0.98	0.82	0.79	0.56	0.98	0.98	0.87	0.84	0.58	0.98	0.98	0.91	0.88	0.61
	kW*	2.38	2.37	2.38	2.30	2.19	2.36	2.36	2.39	2.30	2.19	2.35	2.35	2.40	2.31	2.19
125	MBh ⁺	19.2	19.2	18.7	20.5	22.8	20.0	20.0	19.1	20.9	23.3	20.7	20.8	19.5	21.3	23.6
	S/T	0.98	0.98	0.86	0.83	0.57	0.98	0.98	0.91	0.88	0.60	0.98	0.98	0.95	0.92	0.63
	kW*	2.73	2.72	2.74	2.67	2.56	2.71	2.71	2.75	2.68	2.57	2.71	2.71	2.76	2.68	2.57

Notes: When the required data fall between the published data, interpolation may be performed. Extrapolation is not an acceptable practice.

+Total capacities are net capacities. Blower heat has been subtracted.

++ At TVA rating indoor condition (75 F db/ 63 F wb), All other indoor air temperatures are at 80 F db

* System kW is total unit kW

Standard Rating =

S/T are based on 80°F db entering air at the indoor coil. For sensible capacities at other than 80°5 db, deduct 83° Btuh per 1000 cfm of indoor coil air from (MBh x S/T) for each degree below 80°F, or add 835 Btuh per 1000 cfm of indoor coil air from (MBh x S/T) for each degree above 80°F.

EXPANDED PERFORMANCE DATA: COOLING

PAX342*K**A**

OD Ambient (°F)	ID Airflow (SCFM)	1225					1400					1575				
		Entering Indoor Temperature - Degrees F, Wet Bulb														
		57	62	63 ⁺⁺	67	72	57	62	63 ⁺⁺	67	72	57	62	63 ⁺⁺	67	72
75	MBh ⁺	41.3	42.5	43.2	46.5	50.7	43.2	43.7	44.3	47.6	51.8	44.9	44.9	45.2	48.4	52.7
	S/T	0.98	0.92	0.73	0.70	0.51	0.98	0.97	0.76	0.74	0.53	0.98	0.98	0.80	0.78	0.55
	kW*	2.80	2.81	2.82	2.85	2.89	2.92	2.92	2.93	2.96	3.01	2.99	2.99	3.00	3.03	3.08
85	MBh ⁺	39.7	40.6	41.3	44.4	48.4	41.6	41.7	42.2	45.4	49.4	43.1	43.2	43.0	46.1	50.1
	S/T	0.98	0.94	0.74	0.72	0.52	0.98	0.99	0.78	0.76	0.54	0.98	0.98	0.82	0.79	0.56
	kW*	3.08	3.09	3.10	3.13	3.17	3.20	3.20	3.21	3.24	3.29	3.28	3.28	3.27	3.31	3.35
95	MBh ⁺	38.1	38.6	39.2	42.1	45.9	39.8	39.9	40.0	43.0	46.8	41.2	41.3	40.7	43.7	47.4
	S/T	0.98	0.97	0.76	0.73	0.53	0.98	0.98	0.80	0.78	0.55	0.98	0.98	0.84	0.82	0.57
	kW*	3.39	3.40	3.40	3.44	3.48	3.51	3.51	3.51	3.55	3.59	3.58	3.59	3.58	3.61	3.66
105	MBh ⁺	36.4	36.5	37.0	39.7	43.3	37.9	38.0	37.7	40.5	44.0	39.2	39.3	38.4	41.1	44.6
	S/T	0.98	0.99	0.78	0.75	0.54	0.98	0.98	0.82	0.80	0.56	0.98	0.98	0.87	0.84	0.59
	kW*	3.73	3.73	3.74	3.77	3.82	3.85	3.85	3.85	3.88	3.93	3.92	3.93	3.91	3.95	4.00
115	MBh ⁺	34.4	34.5	34.6	37.1	40.4	35.8	35.9	35.3	37.8	41.1	37.0	37.1	35.8	38.4	41.6
	S/T	0.98	0.98	0.80	0.78	0.55	0.98	0.98	0.85	0.83	0.58	0.98	0.98	0.90	0.88	0.61
	kW*	4.10	4.10	4.10	4.14	4.18	4.22	4.22	4.21	4.25	4.29	4.29	4.29	4.28	4.31	4.36
125	MBh ⁺	32.3	32.3	31.9	34.3	37.2	33.5	33.6	32.5	34.9	37.7	34.5	34.6	33.0	35.3	38.2
	S/T	0.98	0.98	0.84	0.81	0.57	0.98	0.98	0.89	0.87	0.60	0.98	0.98	0.94	0.92	0.63
	kW*	4.50	4.50	4.49	4.53	4.57	4.61	4.62	4.60	4.64	4.68	4.69	4.69	4.67	4.70	4.74

PAX342*K**A (Low Capacity)**

OD Ambient (°F)	ID Airflow (SCFM)	800					900					1000				
		Entering Indoor Temperature - Degrees F, Wet Bulb														
		57	62	63 ⁺⁺	67	72	57	62	63 ⁺⁺	67	72	57	62	63 ⁺⁺	67	72
75	MBh ⁺	30.7	31.4	32.0	34.7	38.4	32.1	32.3	32.8	35.6	39.3	33.3	33.4	33.4	36.3	40.0
	S/T	0.98	0.94	0.75	0.72	0.52	0.98	0.99	0.78	0.75	0.54	0.98	0.98	0.81	0.78	0.55
	kW*	1.35	1.32	1.29	1.16	0.99	1.31	1.30	1.28	1.15	0.97	1.29	1.29	1.28	1.15	0.97
85	MBh ⁺	29.3	29.6	30.2	32.8	36.3	30.6	30.6	30.9	33.5	37.1	31.7	31.8	31.5	34.1	37.7
	S/T	0.98	0.97	0.77	0.74	0.53	0.98	0.98	0.80	0.77	0.55	0.98	0.98	0.83	0.80	0.57
	kW*	1.65	1.64	1.61	1.49	1.33	1.62	1.61	1.60	1.48	1.31	1.60	1.60	1.61	1.49	1.32
95	MBh ⁺	27.8	27.9	28.3	30.8	34.1	29.0	29.1	28.9	31.5	34.8	30.1	30.2	29.5	32.0	35.4
	S/T	0.98	0.98	0.79	0.76	0.54	0.98	0.98	0.82	0.79	0.56	0.98	0.98	0.86	0.83	0.58
	kW*	1.98	1.98	1.96	1.85	1.69	1.95	1.95	1.96	1.84	1.68	1.94	1.93	1.97	1.85	1.69
105	MBh ⁺	26.3	26.4	26.4	28.8	31.9	27.5	27.5	26.9	29.4	32.5	28.5	28.5	27.4	29.9	33.0
	S/T	0.98	0.98	0.81	0.78	0.55	0.98	0.98	0.85	0.82	0.58	0.98	0.98	0.89	0.86	0.60
	kW*	2.34	2.34	2.34	2.23	2.08	2.31	2.31	2.34	2.22	2.07	2.30	2.30	2.35	2.24	2.08
115	MBh ⁺	24.8	24.8	24.4	26.7	29.6	25.8	25.9	24.9	27.2	30.2	26.7	26.8	25.4	27.6	30.6
	S/T	0.98	0.98	0.85	0.81	0.57	0.98	0.98	0.89	0.86	0.59	0.98	0.98	0.93	0.90	0.62
	kW*	2.73	2.72	2.74	2.64	2.50	2.70	2.70	2.75	2.64	2.50	2.70	2.70	2.76	2.66	2.51
125	MBh ⁺	23.1	23.2	22.4	24.5	27.2	24.1	24.1	22.8	24.9	27.7	24.9	24.9	23.2	25.3	28.1
	S/T	0.98	0.98	0.88	0.85	0.59	0.98	0.98	0.93	0.90	0.62	0.98	0.98	0.98	0.95	0.64
	kW*	3.15	3.14	3.18	3.09	2.95	3.13	3.13	3.19	3.09	2.95	3.12	3.12	3.20	3.10	2.97

Notes: When the required data fall between the published data, interpolation may be performed. Extrapolation is not an acceptable practice.

+Total capacities are net capacities. Blower heat has been subtracted.

++ At TVA rating indoor condition (75 F db/ 63 F wb), All other indoor air temperatures are at 80 F db

* System kW is total unit kW

Standard Rating =

S/T are based on 80°F db entering air at the indoor coil. For sensible capacities at other than 80°5 db, deduct 83° Btuh per 1000 cfm of indoor coil air from (MBh x S/T) for each degree below 80°F, or add 835 Btuh per 1000 cfm of indoor coil air from (MBh x S/T) for each degree above 80°F.

EXPANDED PERFORMANCE DATA: COOLING

PAX348*K**A**

OD Ambient (°F)	ID Airflow (SCFM)	1400					1600					1800				
		Entering Indoor Temperature - Degrees F, Wet Bulb														
		57	62	63 ⁺⁺	67	72	57	62	63 ⁺⁺	67	72	57	62	63 ⁺⁺	67	72
75	MBh ⁺	47.6	49.0	49.8	53.7	58.7	49.9	50.4	51.0	54.9	60.0	51.8	51.9	52.0	56.0	61.1
	S/T	0.98	0.93	0.73	0.71	0.51	0.98	0.98	0.77	0.74	0.53	0.98	0.98	0.80	0.78	0.55
	kW*	3.53	3.55	3.56	3.60	3.67	3.68	3.69	3.70	3.75	3.81	3.83	3.83	3.83	3.88	3.94
85	MBh ⁺	45.8	46.8	47.5	51.3	56.1	48.0	48.2	48.7	52.4	57.3	49.8	49.9	49.6	53.4	58.2
	S/T	0.98	0.95	0.75	0.72	0.52	0.98	0.98	0.78	0.76	0.54	0.98	0.98	0.82	0.80	0.56
	kW*	3.86	3.87	3.88	3.93	4.00	4.02	4.02	4.03	4.08	4.14	4.16	4.16	4.16	4.21	4.28
95	MBh ⁺	44.0	44.5	45.2	48.8	53.4	46.0	46.1	46.2	49.8	54.5	47.7	47.8	47.1	50.7	55.3
	S/T	0.98	0.97	0.76	0.74	0.53	0.98	0.98	0.80	0.78	0.55	0.98	0.98	0.84	0.82	0.57
	kW*	4.22	4.23	4.24	4.30	4.36	4.38	4.38	4.39	4.44	4.51	4.53	4.53	4.52	4.57	4.64
105	MBh ⁺	42.1	42.2	42.7	46.2	50.5	44.0	44.0	43.7	47.1	51.5	45.5	45.6	44.5	47.9	52.3
	S/T	0.98	0.98	0.78	0.76	0.54	0.98	0.98	0.83	0.80	0.56	0.98	0.98	0.87	0.84	0.58
	kW*	4.62	4.63	4.64	4.69	4.76	4.78	4.78	4.78	4.84	4.90	4.93	4.93	4.91	4.97	5.03
115	MBh ⁺	40.0	40.1	40.2	43.4	47.5	41.7	41.8	41.0	44.2	48.3	43.2	43.2	41.7	44.9	49.0
	S/T	0.98	0.98	0.81	0.78	0.55	0.98	0.98	0.85	0.83	0.57	0.98	0.98	0.90	0.87	0.60
	kW*	5.06	5.06	5.06	5.12	5.19	5.22	5.22	5.21	5.26	5.33	5.36	5.36	5.34	5.39	5.46
125	MBh ⁺	37.8	37.8	37.4	40.3	44.1	39.3	39.4	38.1	41.0	44.8	40.6	40.6	38.7	41.7	45.3
	S/T	0.98	0.98	0.83	0.81	0.56	0.98	0.98	0.88	0.86	0.59	0.98	0.98	0.93	0.91	0.62
	kW*	5.54	5.54	5.53	5.58	5.65	5.69	5.69	5.67	5.73	5.79	5.83	5.84	5.80	5.86	5.92

PAX348*K**A (Low Capacity)**

OD Ambient (°F)	ID Airflow (SCFM)	950					1100					1250				
		Entering Indoor Temperature - Degrees F, Wet Bulb														
		57	62	63 ⁺⁺	67	72	57	62	63 ⁺⁺	67	72	57	62	63 ⁺⁺	67	72
75	MBh ⁺	33.7	35.0	35.6	38.6	42.6	35.7	36.2	36.7	39.8	43.8	37.3	37.4	37.6	40.7	44.8
	S/T	0.98	0.92	0.73	0.70	0.51	0.98	0.97	0.76	0.73	0.53	0.98	0.98	0.80	0.77	0.55
	kW*	2.03	2.00	1.99	1.92	1.82	2.01	2.00	1.99	1.91	1.81	2.03	2.03	2.03	1.95	1.85
85	MBh ⁺	32.4	33.2	33.9	36.8	40.6	34.2	34.4	34.9	37.8	41.7	35.8	35.8	35.7	38.7	42.6
	S/T	0.98	0.94	0.74	0.71	0.52	0.98	0.99	0.78	0.75	0.54	0.98	0.98	0.82	0.79	0.56
	kW*	2.33	2.31	2.29	2.22	2.13	2.31	2.31	2.29	2.22	2.13	2.33	2.33	2.33	2.26	2.16
95	MBh ⁺	31.0	31.5	32.1	34.8	38.5	32.7	32.8	33.0	35.8	39.6	34.2	34.3	33.7	36.6	40.3
	S/T	0.98	0.97	0.76	0.73	0.53	0.98	0.98	0.80	0.77	0.55	0.98	0.98	0.84	0.81	0.57
	kW*	2.65	2.64	2.63	2.56	2.47	2.64	2.64	2.63	2.57	2.47	2.66	2.66	2.68	2.61	2.51
105	MBh ⁺	29.6	29.7	30.2	32.9	36.4	31.2	31.3	31.1	33.8	37.3	32.6	32.6	31.7	34.5	38.0
	S/T	0.98	0.99	0.78	0.75	0.53	0.98	0.98	0.82	0.80	0.56	0.98	0.98	0.87	0.84	0.58
	kW*	3.01	3.01	3.00	2.94	2.85	3.00	3.00	3.00	2.94	2.85	3.03	3.03	3.05	2.99	2.89
115	MBh ⁺	28.1	28.1	28.3	30.8	34.2	29.6	29.7	29.1	31.6	35.0	30.9	30.9	29.7	32.3	35.6
	S/T	0.98	0.98	0.80	0.77	0.55	0.98	0.98	0.85	0.82	0.57	0.98	0.98	0.90	0.87	0.60
	kW*	3.41	3.41	3.41	3.35	3.27	3.40	3.40	3.42	3.36	3.27	3.43	3.43	3.46	3.40	3.32
125	MBh ⁺	26.5	26.6	26.3	28.7	31.8	27.9	27.9	27.0	29.4	32.5	29.0	29.1	27.5	30.0	33.1
	S/T	0.98	0.98	0.83	0.80	0.56	0.98	0.98	0.89	0.86	0.59	0.98	0.98	0.94	0.91	0.62
	kW*	3.85	3.85	3.86	3.81	3.73	3.85	3.85	3.87	3.82	3.73	3.88	3.88	3.92	3.86	3.78

Notes: When the required data fall between the published data, interpolation may be performed. Extrapolation is not an acceptable practice.

+Total capacities are net capacities. Blower heat has been subtracted.

++ At TVA rating indoor condition (75 F db/ 63 F wb), All other indoor air temperatures are at 80 F db

* System kW is total unit kW

Standard Rating =

S/T are based on 80°F db entering air at the indoor coil. For sensible capacities at other than 80°5 db, deduct 83° Btuh per 1000 cfm of indoor coil air from (MBh x S/T) for each degree below 80°F, or add 835 Btuh per 1000 cfm of indoor coil air from (MBh x S/T) for each degree above 80°F.

EXPANDED PERFORMANCE DATA: COOLING

PAX360*K**A**

OD Ambient (°F)	ID Airflow (SCFM)	1750					2000					2250				
		Entering Indoor Temperature - Degrees F, Wet Bulb														
		57	62	63 ⁺⁺	67	72	57	62	63 ⁺⁺	67	72	57	62	63 ⁺⁺	67	72
75	MBh ⁺	60.5	62.0	63.0	67.2	72.8	63.2	63.6	64.4	68.6	74.1	65.4	65.5	65.5	69.7	75.2
	S/T	0.98	0.93	0.73	0.71	0.51	0.98	0.99	0.77	0.75	0.53	0.98	0.98	0.81	0.79	0.56
	kW*	4.77	4.79	4.81	4.89	5.01	5.08	5.08	5.10	5.18	5.30	5.26	5.26	5.26	5.34	5.46
85	MBh ⁺	58.2	59.1	60.0	64.0	69.2	60.6	60.7	61.2	65.3	70.5	62.7	62.8	62.3	66.3	71.4
	S/T	0.98	0.96	0.75	0.73	0.52	0.98	0.98	0.79	0.77	0.54	0.98	0.98	0.83	0.81	0.57
	kW*	5.22	5.23	5.25	5.34	5.45	5.53	5.53	5.54	5.62	5.73	5.71	5.71	5.70	5.78	5.90
95	MBh ⁺	55.6	56.0	56.8	60.6	65.6	57.9	58.0	57.9	61.7	66.6	59.8	59.9	58.8	62.6	67.5
	S/T	0.98	0.98	0.77	0.74	0.53	0.98	0.98	0.81	0.79	0.55	0.98	0.98	0.85	0.83	0.58
	kW*	5.71	5.71	5.73	5.81	5.92	6.01	6.02	6.01	6.10	6.21	6.20	6.20	6.17	6.26	6.37
105	MBh ⁺	52.9	52.9	53.4	57.0	61.6	55.0	55.0	54.4	58.0	62.5	56.7	56.7	55.3	58.8	63.3
	S/T	0.98	0.98	0.79	0.77	0.54	0.98	0.98	0.83	0.81	0.57	0.98	0.98	0.88	0.86	0.60
	kW*	6.23	6.23	6.24	6.33	6.43	6.54	6.54	6.53	6.61	6.72	6.72	6.72	6.69	6.77	6.88
115	MBh ⁺	49.8	49.9	49.7	53.0	57.2	51.7	51.7	50.6	53.9	58.0	53.2	53.3	51.3	54.6	58.6
	S/T	0.98	0.98	0.81	0.79	0.55	0.98	0.98	0.87	0.85	0.59	0.98	0.98	0.92	0.90	0.62
	kW*	6.80	6.79	6.79	6.87	6.97	7.10	7.10	7.07	7.15	7.25	7.28	7.28	7.23	7.31	7.41
125	MBh ⁺	46.3	46.4	45.6	48.5	52.3	47.9	48.0	46.3	49.3	52.9	49.2	49.3	47.0	49.9	53.5
	S/T	0.98	0.98	0.85	0.83	0.57	0.98	0.98	0.91	0.89	0.61	0.98	0.98	0.96	0.95	0.64
	kW*	7.39	7.39	7.37	7.44	7.54	7.69	7.69	7.65	7.72	7.81	7.86	7.86	7.80	7.88	7.97

PAX360*K**A (Low Capacity)**

OD Ambient (°F)	ID Airflow (SCFM)	1125					1300					1475				
		Entering Indoor Temperature - Degrees F, Wet Bulb														
		57	62	63 ⁺⁺	67	72	57	62	63 ⁺⁺	67	72	57	62	63 ⁺⁺	67	72
75	MBh ⁺	42.6	44.2	45.0	48.2	52.4	44.8	45.5	46.3	49.5	53.7	46.7	46.8	47.2	50.5	54.6
	S/T	0.98	0.91	0.72	0.70	0.51	0.98	0.96	0.76	0.73	0.53	0.98	0.98	0.79	0.77	0.55
	kW*	2.85	2.83	2.82	2.78	2.74	2.87	2.86	2.86	2.82	2.78	2.90	2.90	2.90	2.86	2.81
85	MBh ⁺	41.0	42.2	43.0	46.0	50.0	43.1	43.4	44.1	47.2	51.1	44.9	44.9	45.0	48.0	52.0
	S/T	0.98	0.93	0.74	0.71	0.52	0.98	0.98	0.77	0.75	0.54	0.98	0.98	0.81	0.79	0.56
	kW*	3.24	3.23	3.22	3.18	3.14	3.26	3.26	3.25	3.22	3.17	3.30	3.30	3.30	3.26	3.21
95	MBh ⁺	39.4	40.1	40.8	43.7	47.4	41.3	41.4	41.8	44.7	48.4	42.9	43.0	42.6	45.5	49.2
	S/T	0.98	0.95	0.75	0.73	0.53	0.98	0.98	0.79	0.77	0.55	0.98	0.98	0.83	0.81	0.57
	kW*	3.67	3.66	3.65	3.62	3.57	3.70	3.70	3.69	3.65	3.61	3.73	3.73	3.73	3.69	3.65
105	MBh ⁺	37.6	37.9	38.5	41.2	44.7	39.3	39.4	39.4	42.1	45.6	40.8	40.9	40.1	42.8	46.3
	S/T	0.98	0.98	0.77	0.75	0.54	0.98	0.98	0.81	0.79	0.56	0.98	0.98	0.86	0.84	0.59
	kW*	4.14	4.14	4.13	4.09	4.04	4.17	4.17	4.17	4.13	4.08	4.20	4.20	4.21	4.17	4.12
115	MBh ⁺	35.6	35.6	36.0	38.5	41.8	37.2	37.2	36.8	39.3	42.6	38.5	38.6	37.4	40.0	43.2
	S/T	0.98	0.98	0.79	0.77	0.55	0.98	0.98	0.84	0.82	0.58	0.98	0.98	0.89	0.87	0.61
	kW*	4.65	4.65	4.64	4.61	4.55	4.68	4.68	4.68	4.64	4.59	4.71	4.71	4.72	4.68	4.63
125	MBh ⁺	33.3	33.4	33.3	35.6	38.6	34.8	34.8	33.9	36.3	39.2	35.9	36.0	34.5	36.8	39.7
	S/T	0.98	0.98	0.82	0.80	0.56	0.98	0.98	0.88	0.86	0.60	0.98	0.98	0.93	0.91	0.63
	kW*	5.20	5.19	5.20	5.16	5.10	5.22	5.22	5.24	5.19	5.13	5.25	5.25	5.28	5.23	5.17

Notes: When the required data fall between the published data, interpolation may be performed. Extrapolation is not an acceptable practice.

+Total capacities are net capacities. Blower heat has been subtracted.

++ At TVA rating indoor condition (75 F db/ 63 F wb), All other indoor air temperatures are at 80 F db

* System kW is total unit kW

Standard Rating =

S/T are based on 80°F db entering air at the indoor coil. For sensible capacities at other than 80°5 db, deduct 83° Btuh per 1000 cfm of indoor coil air from (MBh x S/T) for each degree below 80°F, or add 835 Btuh per 1000 cfm of indoor coil air from (MBh x S/T) for each degree above 80°F.

ACCESSORIES

ROOF CURBS

Model Number	Height (K)	Use With Model Size
AXB020CLA	8"	24, 30, 36
AXB020CMA	14"	
AXB020CHA	24"	
AXB030CLA	8"	42, 48, 60
AXB030CMA	14"	
AXB030CHA	24"	

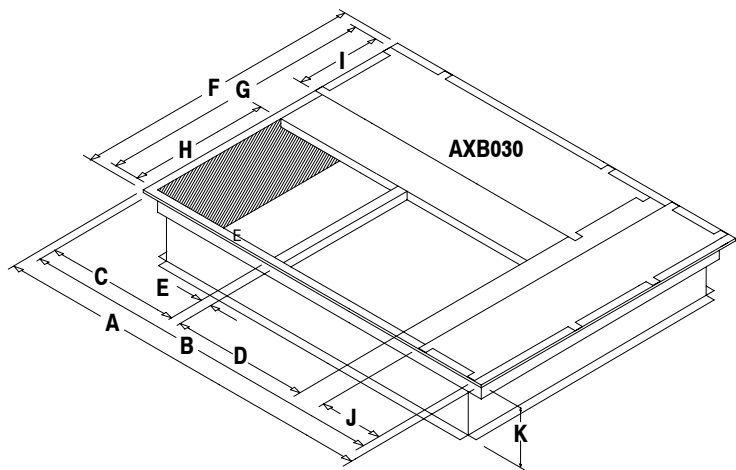
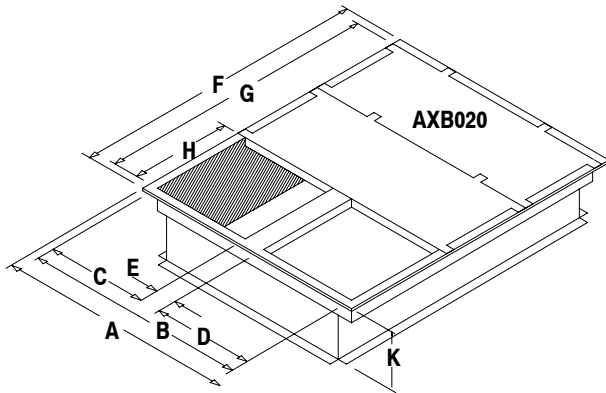

ROOF CURB DIMENSIONS (inches)

Model Number	A	B	C	D	E	F	G	H	I	J	K (LA)	K (MA)	K (HA)
AXB020(L,M,H)A	42-3/4	39-3/4	18	18	3-3/4	42-3/4	39-3/4	18	-	-	8	14	24
AXB030(L,M,H)A	67-3/4	64-3/4	23	23	2-1/2	42-3/4	39-3/4	23	12	12	8	14	24

SQUARE to ROUND TRANSITION

Model Number	Round Size	Use With Roof Curb	Use With Model Size
AXB020CTA	16"	AXB020CLA, AXB020CMA, AXB020CHA	24, 30, 36
AXB030CTA	18"	AXB030CLA, AXB030CMA, AXB030CHA	42, 48, 60

CONCENTRIC GRILLE - FLUSH MOUNT

Model Number	Use With Roof Curb	Use With Model Size
AXB020CFA	AXB020CLA, AXB020CMA, AXB020CHA	24, 30, 36
AXB030CFA	AXB030CLA, AXB030CMA, AXB030CHA	42, 48, 60

CONCENTRIC GRILLE - STEP DOWN

Model Number	Use With Roof Curb	Use With Model Size
AXB020CSA	AXB020CLA, AXB020CMA, AXB020CHA	24, 30, 36
AXB030CSA	AXB030CLA, AXB030CMA, AXB030CHA	42, 48, 60

ACCESSORIES

ECONOMIZERS (ALL FULLY MODULATING)*

Part Number	Application	Motion	Control	Use With Model Size
AXB020HED	Horizontal	Fully Modulating w/ Return Air Damper w/ Relief Damper	Enthalpy	24, 30, 36
AXB030HED				42, 48, 60
AXB020EMD	Downflow			24, 30, 36
AXB030EME				42, 48, 60
AXB020HPE	Horizontal	Fully Modulating w/ Return Air Damper w/ Relief Damper	Dry Bulb Only	24, 30, 36
AXB030HPE				42, 48, 60
AXB020EPE	Downflow			24, 30, 36
AXB030EPF				42, 48, 60

- * Three position economizers no longer available.
 Economizers for model sizes 24, 30, and 36 include Filters and Filter Racks.
 Economizers for model sizes 42, 48, and 60 do NOT include Filters (Filter Racks shipped with unit).

0% - 25% FRESH AIR DAMPERS (use in DOWNFLOW application only) *

Model Number	Control	Use With Model Size
AXB020FAC	Manual	24, 30, 36
AXB030FAC		42, 48, 60
AXB020FMC	Motorized	24, 30, 36
AXB030FMC		42, 48, 60

- * Unit must have internal filters to protect evaporator coil when Fresh Air Damper is installed.
 Model sizes 24, 30, and 36 shipped WITHOUT Filter Racks or Filters.
 Model sizes 42, 48, and 60 shipped WITH Internal Filter Racks, but WITHOUT Filters.

FILTER RACK and FILTER *

Model Number	Application	Filter Location	Filter Size	Use With Model Size
AXB020FKA	Downflow	Internal	18 x 25 x 1	24, 30, 36
AXB020FHC	Horizontal	External	20 x 25 x 1	

- * Model sizes 24, 30, and 36 shipped WITHOUT Filter Racks or Filters.
 Model sizes 42, 48, and 60 shipped WITH Internal Filter Racks, but WITHOUT Filters.

LOW AMBIENT CONTROL

FAST Part Number	Description	Use With Model Size
1148232	Freeze 'stat, opens 30° F, closes 50° F	ALL
ALA14CU0A	R-410A Low Ambient Control	ALL

COIL PROTECTION

FAST Part Number	Description	Use With Model Size
1149485	Coil Guard, black, two-piece	24, 30, 36
1068133	Hail Guard, black, two-piece	24, 30, 36
1149486	Coil Guard, black, three-piece	42, 48, 60
1068134	Hail Guard, black, three-piece	42, 48, 60

OUTDOOR THERMOSTAT

Model Number	Description	Use With Model Size
AMF002OTA	2 Stage, Electronic	ALL

UNIT DIMENSIONS

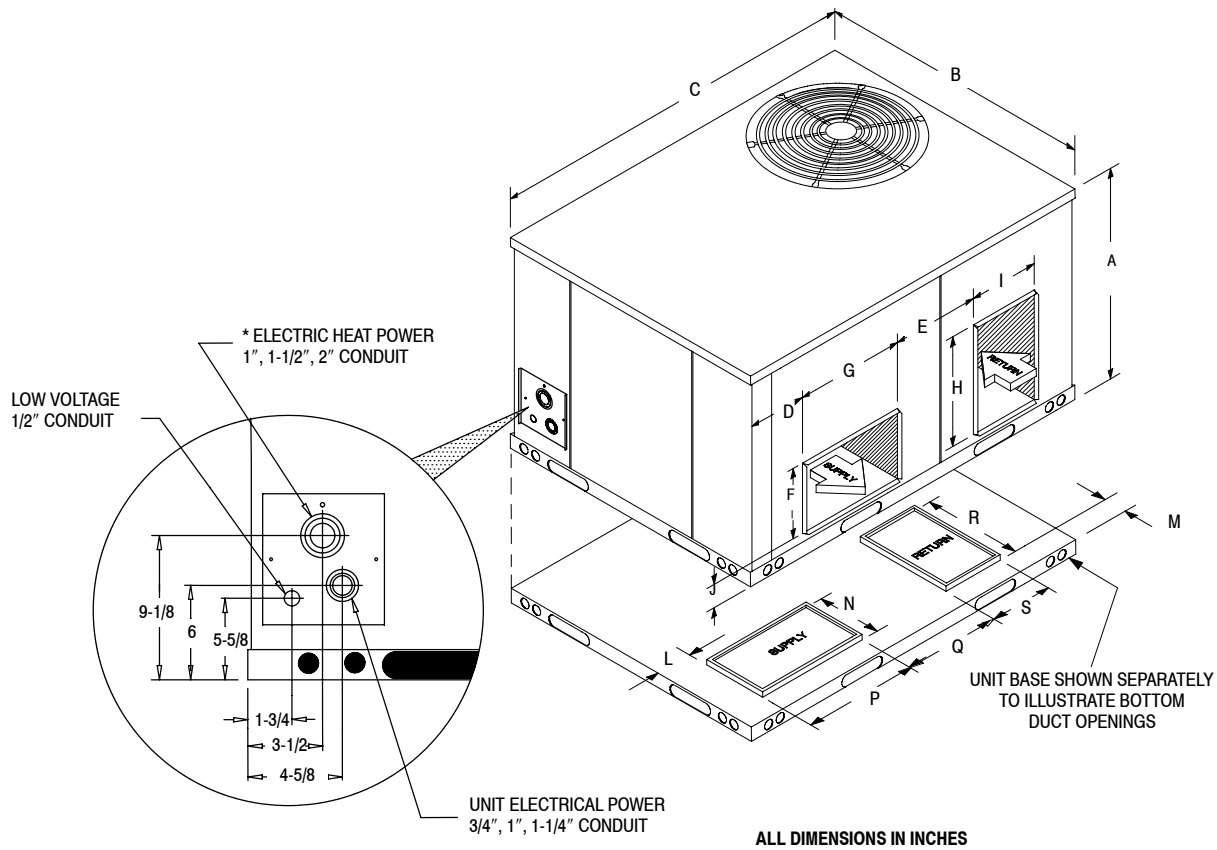

Model Size	A	B	C	D	E	F	G	H	I	J	K	L	M	N**	P**	Q	R	S	Bottom L x W * Inside Base Rail
2, 2½, 3 Ton	32-1/2	47-3/8	47-3/8	3-1/8	11-1/8	12	14-1/4	14-1/4	12	4	*	4-1/4	4-3/8	14-1/2	12-1/4	12-1/8	14-1/4	12-1/4	43-1/8 x 43-1/8
3½, 4, 5 Ton	36	47-3/8	73	4-5/8	15	12	18-3/4	18-3/4	12	4	*	4-1/4	5-1/4	12-1/4	19	15	19	12-1/4	68-3/4 x 43-1/8

** The supply opening in the drawing is shown for the orientation in the 3-1/2 to 5 Ton units. The opening for the 2 to 3 Ton units is rotated 90°, so the N and P dimensions are correct.

MODEL NUMBER IDENTIFICATION GUIDE

Product Family	SEER	Nominal Cooling Capacity Btuh	Heating Input Btuh	Voltage	Option Code	Design Code	Eng. Rev. Code
PAX - Package Air Conditioner, R-410A	3 = 13	24 = 24,000	000 = N/A	K = 208/230-1-60	00 = N/A	A	1
		30 = 30,000					
		36 = 36,000					
		42 = 42,000					
		48 = 48,000					
60 = 60,000							
Example: PAX	3	24	000	K	00	A	1

GUIDE SPECIFICATIONS

CABINET

The cabinet is made of G-90 galvanized steel, phosphate coated with a tough acrylic finish coat for long lasting weatherproof construction. The base rails are 18 gauge steel with fork lift slots and holes provided for lifting shackles. The unit is designed with convertible airflow for either horizontal or downflow applications with conversion accomplished by re-locating two panels. Indoor blower compartment interior cabinet surfaces are insulated with a minimum 3/4" thick, flexible glass insulation, coated on the air side. Aluminum foil faced glass fiber insulation is used in the furnace compartment.

COOLING SECTION

The unit is factory charged and operationally ready upon delivery. The unit refrigerant circuit has a high efficiency fully hermetic compressor with internal overload protection, and copper tube / aluminum fin evaporator and condenser coils. The unit is designed for cooling operation to 40° F and will be capable of being wired for field installed economizer type accessories.

COILS

The evaporator and condenser coils are fabricated with aluminum fins mechanically bonded to copper tubing. Both coils are pressure tested prior to assembly into the unit and electronically leak tested after assembly into the unit.

CONDENSER FAN

The unit has a single direct-drive propeller-fan / motor assembly. The assembly is mounted directly to a vertical-discharge grille that is easily removed for service. Motors are 1100 RPM with sleeve or ball bearings and internal overload protection.

EVAPORATOR BLOWER

All units have a direct-drive high efficiency brushless DC evaporator blower motor as a standard. The direct-drive evaporator blower motor has sleeve bearings and internal overload protection.

INSTALLATION CLEARANCES

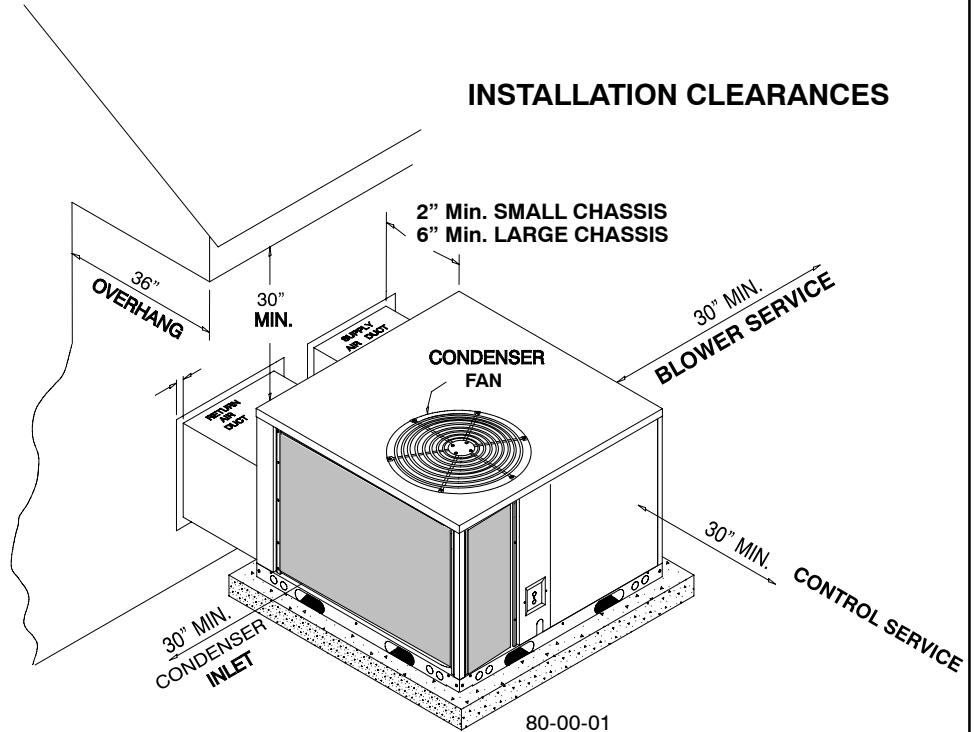

RIGGING DETAILS

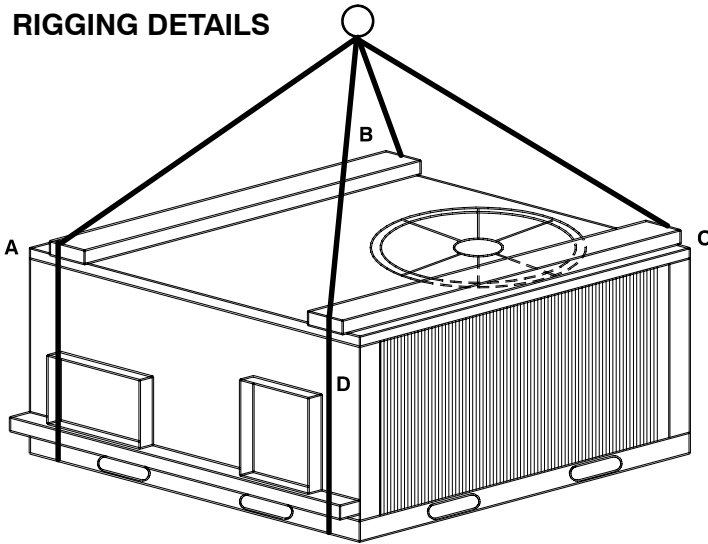

OPERATING WEIGHTS (LBS)

MODEL	OPERATING WEIGHT TOTAL
PAX324	406
PAX330	358
PAX336	415
PAX342	529
PAX348	529
PAX360	590

International Comfort Products, LLC
Lewisburg, Tennessee 37091 U.S.A.
www.GoComfortmaker.com