

PGB SERIES

7-1/2 thru 20 Ton

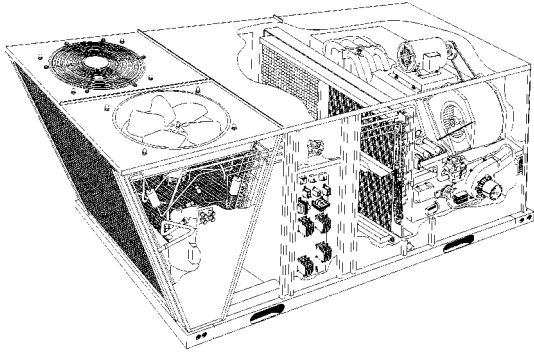

Twenty Ton Unit

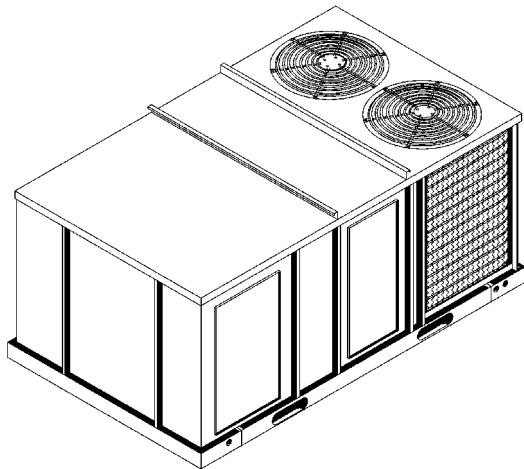

Ten Ton Unit



Rated in accordance with ARI Standard 210.



Listed By Underwriters' Laboratories

CONVERTIBLE SINGLE PACKAGE GAS/ELECTRIC

COMMERCIAL GAS/ELECTRIC UNIT FEATURES

CAPACITY

- 7-1/2 thru 20 ton Cooling, 200,000 thru 270,000 BTUH Heating

SINGLE PACKAGE

- Combination gas heating and electric cooling, self contained for year-round comfort. Systems can be installed on rooftop or ground level with the new convertible design.

CONSTRUCTION

- Triple step pre-painted galvanized steel cabinet for long lasting weatherproof construction. Access panels for easy service. Side by side supply and return. Heavy 16 gauge base with rails.

INTEGRAL BASE RAILS

- Fork-lift access on three sides. Holes provided for lifting lugs makes rooftop installation easier.

IMPROVED INSULATION

- Dual density insulation improves temperature separation.

COPPER TUBE/ALUMINUM FIN COILS

- Enhanced aluminium fins mechanically bonded to copper tubes for improved heat transfer.

FILTER DRIERS

- To insure refrigerant cleanliness.

HIGH & LOW PRESSURE SWITCH

- To provide excellent compressor protection.

EXTERNALLY-MOUNTED GAUGE PORTS

- Allows for more accurate reading of operating conditions while servicing.

INNOVATIVE EVAPORATOR BLOWER DESIGN

- "No Difference" Design allows the evaporator blower to deliver the same static capability for either horizontal or down discharge applications.

INTERNAL AIR FILTERS

- Easy access air filters to maintain a clean evaporator coil.

INDUCED DRAFT COMBUSTION SYSTEM

- For smoother combustion and optimal efficiency.

ALUMINIZED TUBULAR HEAT EXCHANGER

- Tubular design delivers efficient heat transfer and air flow: aluminized coating protects against corrosion.

IN-SHOT BURNERS

- New design delivers more complete, efficient combustion.

TWO STAGE HEATING

- Two independent circuits

PRE-WIRED FOR ECONOMIZER

- Designed for slide in, plug in economizer installation.

RESIDENTIAL AND COMMERCIAL SYSTEMS • SPLIT SYSTEMS • PACKAGED AIR CONDITIONERS
• COMBINATION GAS / ELECTRIC UNITS • HEAT PUMPS • AIR HANDLERS • MANUFACTURED HOME AIR CONDITIONERS • GAS, OIL AND ELECTRIC FURNACES

International Comfort Products
650 Heil-Quaker Avenue, Lewisburg, TN 37091

509 56 1001 02

7/97

UNIT SPECIFICATIONS

Model Number		PGB090H2H	PGB090H2L	PGB090H2S	PGB120I2H	PGB120I2L	PGB120I2S	PGB150J2H	PGB150J2L	
Electrical	Volts-Phase-Hz.	208/230-3-60	460-3-60	600-3-60	208/230-3-60	460-3-60	600-3-60	208/230-3-60	460-3-60	
Data	Ampacity	41.1	20.7	15.0	56.63	29.7	23.3	65.7	33.7	
	MaxFuse	50	25	20	70*	35	30	90*	45	
Condenser	Coil	Total Face Area-Sq Ft			23			28		
	Data	Fins Per In. / Rows			20 / 2			20 / 2		
		Tube Diameter (In.)			3/8			3/8		
Fan	Horsepower / Quantity	3/4/1			3/4/2			3/4/2		
Motor	Full Load Amps.	3.5	1.8	1.4	3.5	1.8	1.4	3.5	1.8	
	Locked Rotor Amps.	10	3.9	2.7	10	3.9	2.7	10	3.9	
Fan	Size Diameter (In.)	1(24)			2(22)			2(24)		
	RPM (Maximum)	1100			1100			1100		
	CFM (Maximum)	5800x1			4600x2			5800x2		
Evaporator	Coil	Total Face Area-Sq Ft			9.7			13.9		
	Coil	Circuits /Fins Per In. / Rows			2 / 14 / 3			2 / 14 / 3		
		Tube Diameter (In.)			3/8			3/8		
Blower	H. P.	2	2	2	2	2	2	3	3	
Motor	Full Load Amps.	6.8	3.4	2.7	10.4	5.2	2.7	9.2	4.6	
	Locked Rotor Amps.	57.5	28.9	19.5	57.5	28.9	19.5	73.0	36.8	
Blower	Type & Size	12x12 Belt Drive			12x12 Belt Drive			15x15 Belt Drive		
	RPM (Maximum)	1800			1800			1500		
	CFM Rated	3000			3800			5000		
Compressor	Quantity / Type	2 / Recip			2 / Recip			2 / Recip		
	Rated Load Amps.	#1	13.7	6.9	4.9	17.9	7.9	6.4	23.9	12.0
		#2	13.7	6.9	4.9	17.9	7.9	6.4	19.6	10.4
	Lock Rotor Amps.	#1	82	41	30	128	63	50	185	89
#2		82	41	30	128	63	50	105	55	
Factory Refrig. Charge R-22 oz. per Circuit		#1 - 135 #2 - 135			#1 - 150 #2 - 150			#1 - 210 #2 - 210		
Weight	Shipping (Lbs.)	1095			1145			1245		
Air Filter	Size / Quantity	20 x 25 x 2 / 4			20 x 25 x 2 / 4			20 x 25 x 2 / 4		

UNIT SPECIFICATIONS

Model Number		PGB150J2S	PGB180J2H	PGB180J2L	PGB180J2S	PGB240J2H	PGB240J2L	PGB240J2S	
Electrical	Volts-Phase-Hz.	600-3-60	208/230-3-60	460-3-60	600-3-60	208/230-3-60	460-3-60	600-3-60	
Data	Ampacity	25.4	70.0	38.1	28.8	119.4	60	50.8	
	MaxFuse	35	100	50	35	150	70	60	
Condenser	Coil	Total Face Area (Sq.Ft.)			28			2 @ 20	
	Data	Fins Per In. / Rows			20 / 2			2 @ 20 / 2	
		Tube Diameter (In.)			3/8			3/8	
Fan	Horsepower / Quantity	3/4/2			2 @ 3/4			2 @ 1 1/2	
Motor	Full Load Amps.	1.4	3.5	1.8	1.4	5.2	2.6	2.2	
	Locked Rotor Amps.	2.6	1.0	3.9	2.6	23	11.5	9.5	
Fan	Size Diameter (In.)	2(24)			2 (24)			2 (24)	
	RPM (Maximum)	1100			1100			1100	
	CFM (Maximum)	5800x2			5800 x 2			8000 x 2	
Evaporator	Coil	Total Face Area (Sq.Ft.)			13.9			16.2	
	Coil	/Fins Per In. / Rows			2 / 14 / 3			2 / 15 / 4 Hyd.	
		Tube Diameter (In.)			3/8			3/8	
Blower	H. P.	3	3	3	3	10	10	10	
Motor	Full Load Amps.	3.6	15.0	7.5	5.4	25.3	12.7	11.5	
	Locked Rotor Amps.	21.8	73.0	36.8	41.6	166.0	83	64.1	
Blower	Type & Size	15x15 Belt Drive			15x15 Belt Drive			15x15 Belt Drive	
	RPM (Maximum)	1500			1500			1800	
	CFM Rated	5000			6000			7200	
Compressor	Quantity / Type	2 / Recip			2 / Recip			2 / Scroll	
	Rated Load Amps.	#1	9.6	23.9	12.0	9.6	36.0	18.0	15.0
		#2	7.0	23.9	12.0	9.6	38.7	19.4	16.2
	Lock Rotor Amps.	#1	78.4	185	89	78.4	255	127	100
#2		45	185	89	78.4	255	127	100	
Factory Refrigerant Charge R-22 oz. per Circuit		#1 - 210 #2 - 210			#1 - 210 #2 - 210			#1 - 270 #2 - 270	
Weight	Shipping (Lbs.)	1245			1300			1900	
Air Filter	Size / Quantity	20 x 25 x 2 / 4			20 x 25 x 2 / 4			20 x 25 x 2 / 4	

PERFORMANCE DATA: HEATING

Model Number	Heating Capacity Data				Capacity Stages%	Heating Thermal Efficiency		Temperature Rise Range-Deg. F	
	Input (MBTUH)		Output (MBTUH)			Heating	1st STAGE	2nd STAGE	1st STAGE
	1st STAGE	2nd STAGE	1st STAGE	2nd STAGE					
PGB090H	134	200	104	160	66 / 100	78%	80%	15 - 45	30 - 60
PGB120I	160	240	125	192	66 / 100	78%	80%	15 - 45	30 - 60
PGB150J	180	270	141	216	66 / 100	78%	80%	15 - 45	30 - 60
PGB180J	180	270	141	216	66 / 100	78%	80%	15 - 45	30 - 60
PGB240J	180	270	141	216	66 / 100	78%	80%	15 - 45	25 - 55

PERFORMANCE DATA: COOLING

Model Number	Rated Capacity ¹ BTUH	S/T Ratio	EER	I.P.L.V.	Capacity Stages% Cooling	Evaporator Rated Airflow
PGB090	90,000	.76	9.1	9.9	50 / 100	3000SCFM
PGB120	118,000	.78	9.1	9.5	50 / 100	3800SCFM
PGB150	152,000	.72	8.5	8.3	60 / 100	5000SCFM
PGB180	180,000	.72	8.5	8.3	50 / 100	6000SCFM
PGB240	240,000	.71	8.5	8.3	50 / 100	7200SCFM

¹ Net Capacity Ratings based on ARI Test Standards, 95° F Amb. 80° F DB / 67° F WB.

MODEL NUMBER IDENTIFICATION GUIDE

MODEL NUMBER	P	G	B	090	H	2	H
Product Family	P = Single Package						Electrical Characteristics
Fuel Type	G = Gas / Electric						H = 208 / 230-3-60 L = 460-3-60 S = 600-3-60
Design Series							Blower Options
Capacity (Nominal BTU)	090 = 7-1/2 Ton 150 = 12-1/2 Ton 120 = 10 Ton 180 = 15 Ton 240 = 20 Ton						Gas Heat Input
							J = 270,000 I = 240,000 H = 200,000

CIRCULATING BLOWER PERFORMANCE DATA - 7¹/₂ TON UNITS

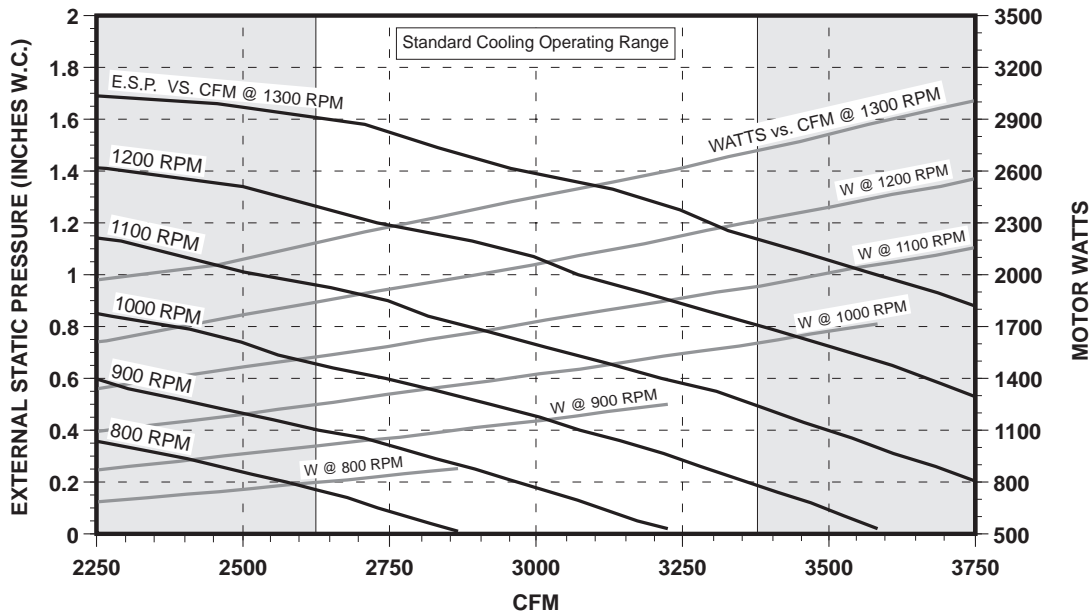

- NOTES:**
- 1) Maximum motor Watts is 3200 Watts for 2 HP.
 - 2) Maximum blower wheel speed is 1800 RPM.
 - 3) Contact factory for applications requiring operation outside standard cooling operating range.
 - 4) Airflow data based on dry coil with filters. For wet coil add 0.08 inches to ESP. Downflow has the same ESP as horizontal flow.
 - 5) Add 0.05 inches to ESP for horizontal economizer, downflow economizer, or manual air dampers.
 - 6) Pulley turns refers to turns out. In other words, 0 turns is a *narrower* sheave than 5 turns.
 - 7) Blower speed **MUST** be set to give the correct air temperature rise through the unit as marked on the Rating Plate or in the *Technical Support Manual*.

CFM	EXTERNAL STATIC PRESSURE IN INCHES WATER COLUMN																			
	.25		.5		.75		1.0		1.25		1.50		1.75		2.0		2.25		2.5	
	RPM	W	RPM	W	RPM	W	RPM	W	RPM	W	RPM	W	RPM	W	RPM	W	RPM	W	RPM	W
2500					1000	1250	1100	1500	1175	1700	1260	2000	1340	2250						
2750			960	1250	1050	1400	1140	1750	1224	2000	1290	2250	1360	2500						
3000	945	1250	1010	1500	1100	1750	1190	2000	1250	2250	1325	2600								
3250	1000	1550	1075	1800	1160	2100	1240	2400	1300	2600	1391	3050								
3500	1050	1800	1125	2150	1200	2250	1290	2600	1350	2800										

W = Watts High Static Data

PULLEY TURNS OPEN		0	1	2	3	4	5
FAN RPM	2 HP/STD PULLEY	1224	1139	1113	1057	1001	945
	2 HP/Hi STATIC PULLEY	1391	1335	1280	1224	1169	1113

NOTE: High static pulleys are field installed and **MUST** be adjusted by the installing technician.

FACTORY SETTING TURNS OPEN	
2 HP/STANDARD PULLEY	4
2 HP/Hi STATIC PULLEY *	(See NOTE)

AIRFLOW CORRECTION FACTORS - 7 1/2 TON

CFM - ACTUAL	2600	2800	3000	3200	3400
TOTAL MBH	0.97	0.98	1.00	1.02	1.03
SENSIBLE MBH	0.93	0.97	1.00	1.03	1.07
POWER KW	0.99	0.99	1.00	1.01	1.01

- NOTES:**
1. Multiply correction factor times gross performance data.
 2. Resulting sensible capacity cannot exceed total capacity.

CIRCULATING BLOWER PERFORMANCE DATA - 10 TON UNITS

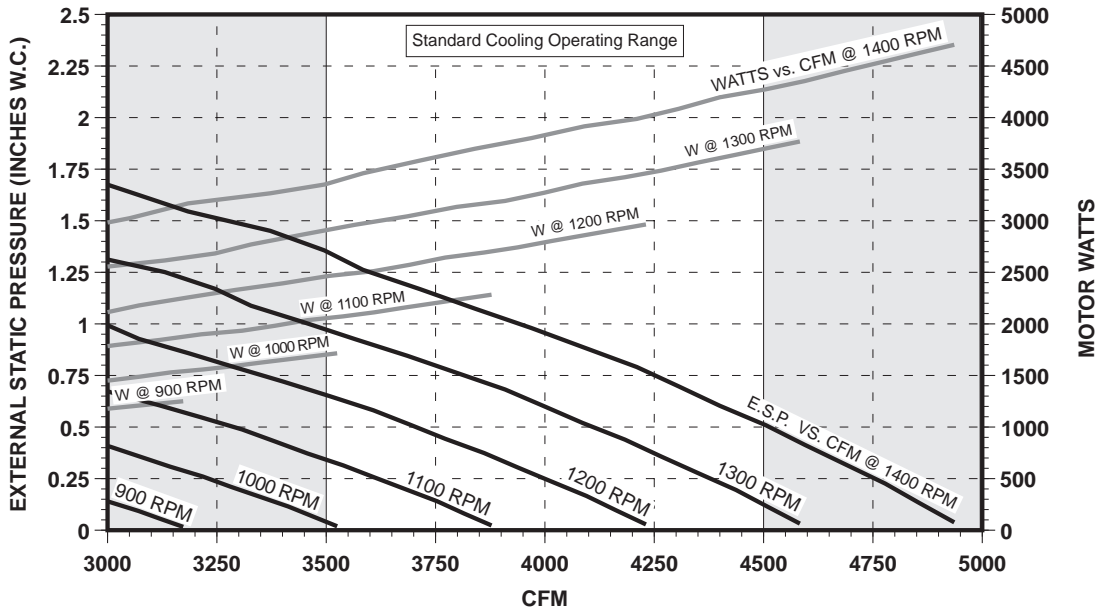

- NOTES: 1) Maximum motor Watts is 4250 Watts for 2 HP and 4900 Watts for 3 HP.
 2) Maximum blower wheel speed is 1800 RPM.
 3) Contact factory for applications requiring operation outside standard cooling operating range.
 4) Airflow data based on dry coil with filters. For wet coil add 0.08 inches to ESP. Downflow has the same ESP as horizontal flow.
 5) Add 0.10 inches to ESP for horizontal economizer, downflow economizer, or manual air dampers.
 6) Pulley turns refers to turns out. In other words, 0 turns is a narrower sheave than 5 turns.
 7) Blower speed MUST be set to give the correct air temperature rise through the unit as marked on the Rating Plate or in the *Technical Support Manual*.

CFM	EXTERNAL STATIC PRESSURE IN INCHES WATER COLUMN																				
	.25		.5		.75		1.0		1.25		1.50		1.75		2.0		2.25		2.5		
	RPM	W	RPM	W	RPM	W	RPM	W	RPM	W	RPM	W	RPM	W	RPM	W	RPM	W	RPM	W	
3500			1150	2250	1225	2600	1310	3000	1380	3250	1440	3625	1525	4000							
3750	1140	2375	1210	2700	1290	3000	1360	3350	1425	3750	1500	4200	1558	4400							
4000	1200	2800	1275	3125	1350	3600	1420	3850	1475	4250	1540	4550									
4250	1260	3250	1325	3625	1390	3900	1475	4500	1525	4650											
4500	1325	3850	1390	4250	1460	4600	1520	4900													

W = Watts High Static Data

PULLEY TURNS OPEN		0	1	2	3	4	5
FAN RPM	2 HP/STD PULLEY	1391	1335	1280	1224	1169	1113
	3 HP/HI STATIC PULLEY	1558	1502	1446	1391	1335	1280

NOTE: High static pulleys are field installed and MUST be adjusted by the installing technician.

FACTORY SETTING TURNS OPEN	
2 HP/STANDARD PULLEY	4
3 HP/HIGH STATIC PULLEY*	(See NOTE)

AIRFLOW CORRECTION FACTORS - 10 TON					
CFM - ACTUAL	3200	3600	4000	4400	4800
TOTAL MBH	0.95	0.97	1.00	1.03	1.05
SENSIBLE MBH	0.89	0.95	1.00	1.05	1.11
POWER KW	0.98	0.99	1.00	1.01	1.02

- NOTES: 1. Multiply correction factor times gross performance data.
 2. Resulting sensible capacity cannot exceed total capacity.

CIRCULATING BLOWER PERFORMANCE DATA - 12¹/₂ TON UNITS

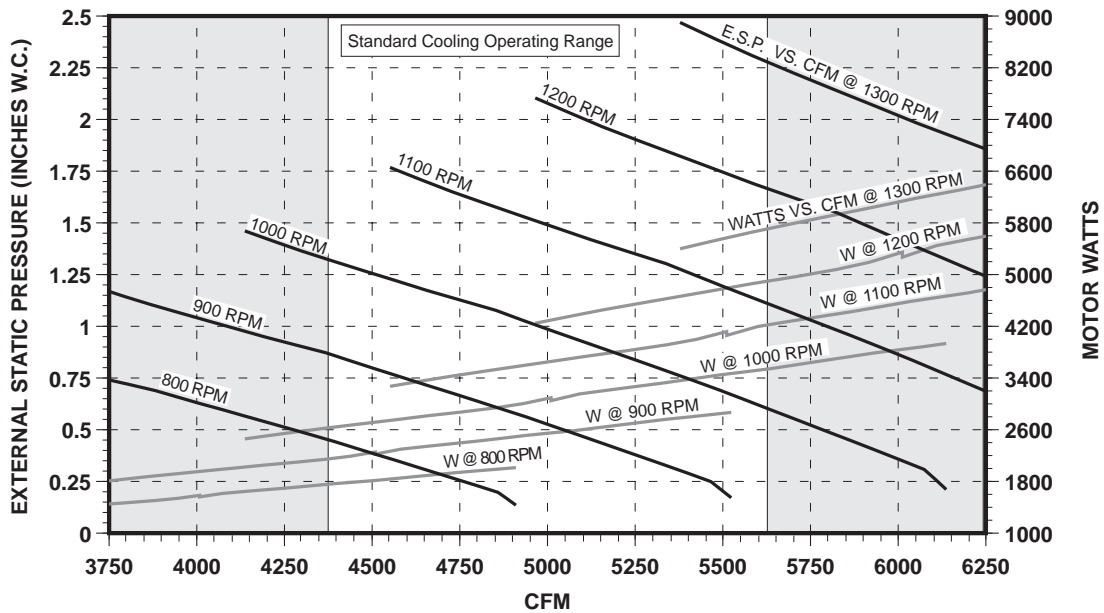

- NOTES: 1) Maximum motor Watts is 5200 Watts for 3 HP; 6200 Watts for 5 HP.
 2) Maximum blower wheel speed is 1550 RPM.
 3) Contact factory for applications requiring operation outside standard cooling operating range.
 4) Airflow data based on dry coil with filters. For wet coil add 0.08 inches to ESP. Downflow has the same ESP as horizontal flow.
 5) Add 0.15 inches to ESP for horizontal economizer, downflow economizer, or manual air dampers.
 6) Pulley turns refers to turns out. In other words, 0 turns is a *narrower* sheave than 5 turns.
 7) Blower speed **MUST** be set to give the correct air temperature rise through the unit as marked on the Rating Plate or in the *Technical Support Manual*.

CFM	EXTERNAL STATIC PRESSURE IN INCHES WATER COLUMN																			
	.25		.5		.75		1.0		1.25		1.50		1.75		2.0		2.25		2.5	
	RPM	W	RPM	W	RPM	W	RPM	W	RPM	W	RPM	W	RPM	W	RPM	W	RPM	W	RPM	W
4500					890	2050	950	2500	1000	2700	1050	3000	1090	3100	1140	3450	1175	3800	1220	4000
4750					925	2500	975	2750	1025	2975	1075	3250	1125	3000	1160	3800	1200	4100		
5000			900	2500	950	2750	1000	3025	1050	3350	1100	3625	1150	4000	1190	4200	1230	4550		
5250	875	2500	925	2875	975	3075	1025	3450	1075	3625	1125	4000	1175	4375	1220	4750				
5500	900	2875	960	3150	1010	3525	1060	3825	1110	4250	1150	4375	1200	4750	1236	5000				
5750	950	3250	1000	3625	1050	3900	1100	4375	1140	4600	1180	4825	1230	5125						

W = Watts High Static Data

PULLEY TURNS OPEN		0	1	2	3	4	5
FAN RPM	3 HP/STD PULLEY	1150	1097	1045	993	940	888
	5 HP/HI STATIC PULLEY	1236	1172	1107	1042	977	911

NOTE: High static pulleys are field installed and **MUST** be adjusted by the installing technician. 5 HP motor requires a *blower* pulley change.

FACTORY SETTING TURNS OPEN	
3 HP/STANDARD PULLEY	4
5 HP/HI STATIC PULLEY *	(See NOTE)

AIRFLOW CORRECTION FACTORS - 12 1/2 TON

CFM - ACTUAL	4000	4500	5000	5500	6000
TOTAL MBH	0.95	0.98	1.00	1.02	1.05
SENSIBLE MBH	0.90	0.95	1.00	1.05	1.10
POWER KW	0.98	0.99	1.00	1.01	1.02

- NOTES: 1. Multiply correction factor times gross performance data.
 2. Resulting sensible capacity cannot exceed total capacity.

CIRCULATING BLOWER PERFORMANCE DATA - 15 TON UNITS

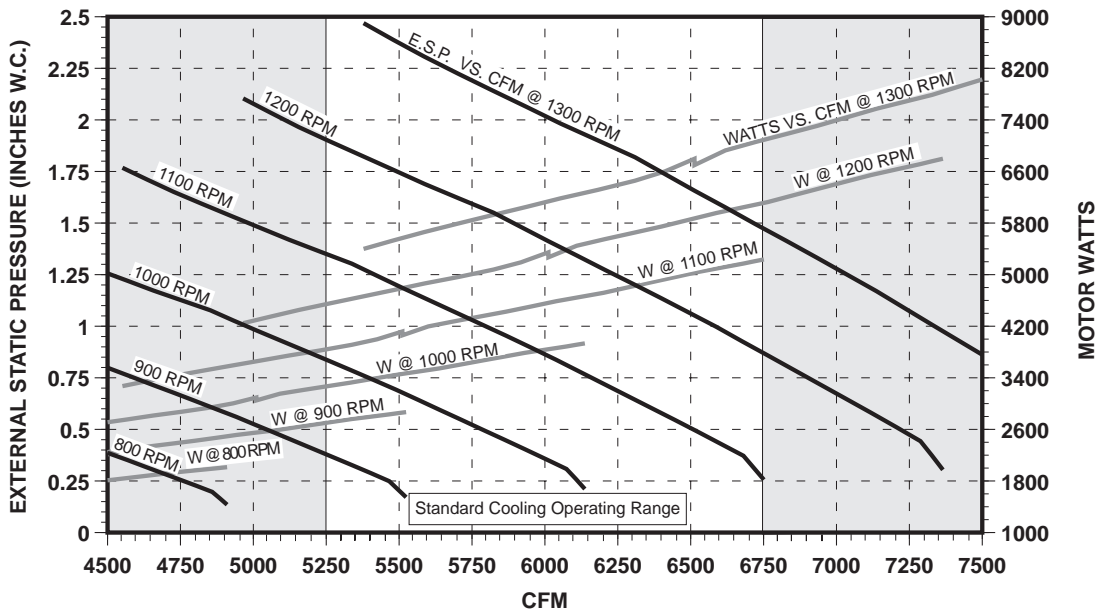

- NOTES:**
- 1) Maximum motor Watts is 5200 Watts for 3 HP; 6200 Watts for 5 HP.
 - 2) Maximum blower wheel speed is 1550 RPM.
 - 3) Contact factory for applications requiring operation outside standard cooling operating range.
 - 4) Airflow data based on dry coil with filters. For wet coil add 0.08 inches to ESP. Downflow has the same ESP as horizontal flow.
 - 5) Add 0.20 inches to ESP for horizontal economizer, downflow economizer, or manual air dampers.
 - 6) Pulley turns refers to turns out. In other words, 0 turns is a *narrower* sheave than 5 turns.
 - 7) Blower speed **MUST** be set to give the correct air temperature rise through the unit as marked on the Rating Plate or in the *Technical Support Manual*.

CFM	EXTERNAL STATIC PRESSURE IN INCHES WATER COLUMN																			
	.25		.5		.75		1.0		1.25		1.50		1.75		2.0		2.25		2.5	
	RPM	W	RPM	W	RPM	W	RPM	W	RPM	W	RPM	W	RPM	W	RPM	W	RPM	W	RPM	W
5250	875	2500	925	2875	975	3075	1025	3450	1075	3625	1125	4000	1175	4375	1220	4750				
5500	900	2875	960	3150	1010	3525	1060	3825	1110	4250	1150	4375	1200	4750	1236	5000				
5750	950	3250	1000	3625	1050	3900	1100	4375	1140	4600	1180	4825	1230	5125						
6000	990	3625	1025	4000	1075	4375	1125	4750	1160	4900	1215	5500								
6250	1025	4200	1060	4475	1110	4850	1160	5200	1200	5600										
6500	1060	4700	1100	5025	1150	5450	1190	5800	1236	6000										
6750	1100	5125	1140	5500	1180	5875														

W = Watts High Static Data

PULLEY TURNS OPEN		0	1	2	3	4	5
FAN RPM	3 HP/STD PULLEY	1150	1097	1045	993	940	888
	5 HP/HI STATIC PULLEY	1236	1172	1107	1042	977	911

AIRFLOW CORRECTION FACTORS - 15 TON

CFM - ACTUAL	4800	5400	6000	6600	7200
TOTAL MBH	0.95	0.98	1.00	1.02	1.05
SENSIBLE MBH	0.90	0.95	1.00	1.05	1.10
POWER KW	0.98	0.99	1.00	1.01	1.02

- NOTES:**
1. Multiply correction factor times gross performance data.
 2. Resulting sensible capacity cannot exceed total capacity.

FACTORY SETTING TURNS OPEN	
3 HP/STANDARD PULLEY	4
5 HP/HI STATIC PULLEY *	(See NOTE)

CIRCULATING BLOWER PERFORMANCE DATA - 20 TON UNITS

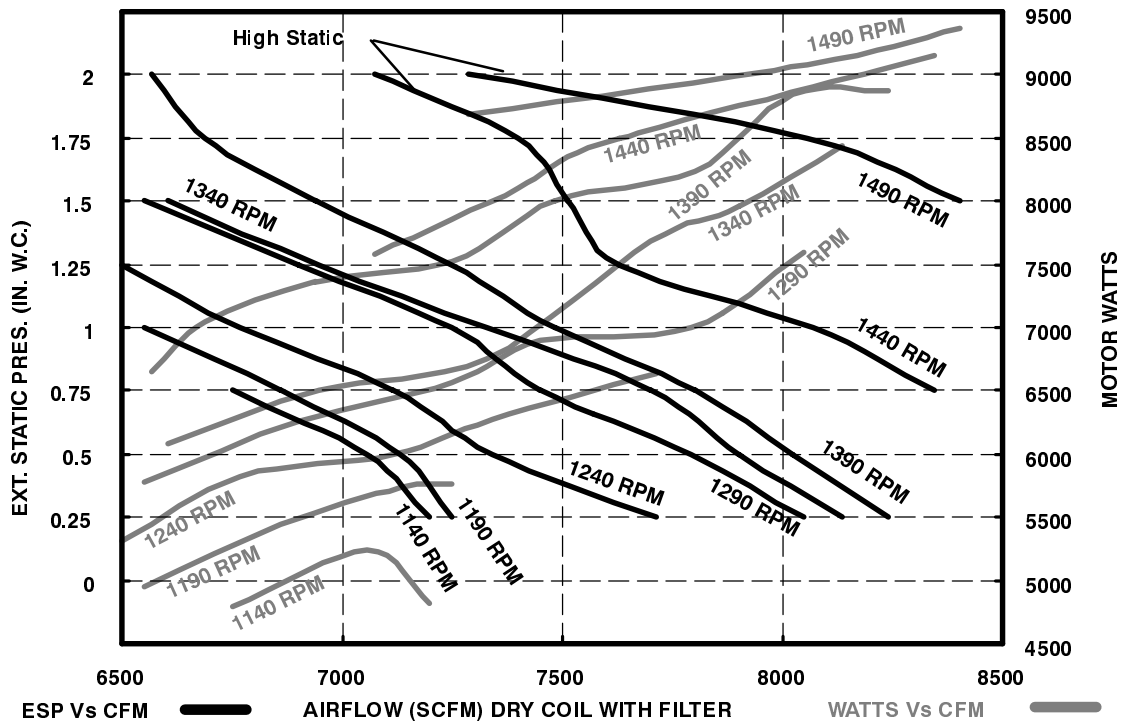

NOTES: 1) Maximum motor Watts is 10,100 Watts. 2) Maximum blower wheel speed is 1800 RPM. 3) Contact factory for applications requiring operation outside standard cooling operating range. 4) Airflow data based on dry coil with filters. For wet coil add 0.08 inches to ESP. Downflow has the same ESP as horizontal flow. 5) Add 0.20 inches to ESP for horizontal economizer, downflow economizer, or manual air dampers. 6) Pulley turns refers to turns out. In other words, 0 turns is a narrower sheave than 5 turns. 7) Blower speed MUST be set to give the correct air temperature rise through the unit as marked on the Rating Plate.

CFM	EXTERNAL STATIC PRESSURE IN INCHES WATER COLUMN (PASCALS)																
	.25 (62)		.50 (124)		.75 (186)		1.0 (249)		1.25 (311)		1.50 (373)		1.75 (435)		2.0 (497)		
	RPM	W	RPM	W	RPM	W	RPM	W	RPM	W	RPM	W	RPM	W	RPM	W	
6750														1390	7100	1410	7300
7000					1220	5800	1265	6250	1350	6650	1380	7200	1410	7400	1430	7600	
7250	1190	5760	1220	5920	1260	6300	1290	6550	1390	7500	1410	7700	1425	7750	1480	8600	
7500	1220	6150	1255	6500	1300	6950	1390	8010	1420	8250	1440	8400	1460	8650			
7750	1250	6750	1280	6850	1360	8000	1420	8450	1450	8700	1460	9750	1475	8800			
8000	1280	7300	1380	8800	1420	8800	1433	8870	1455	8950	1470	9000	1480	9050			
8250	1400	8890	1420	9150	1432	9200	1455	9250	1470	9270	1480	9300					

High Static Data

NOTE: DO NOT EXCEED 25.3 AMPS ON BLOWER MOTOR AT ANY POINT.

PULLEY TURNS OPEN		0	1	2	3	4	5
FAN	STD PULLEY	1390	1340	1295	1245	1195	1140
RPM	HIGH STATIC PULLEY	1540	1495	1445	1390	1345	1295

AIRFLOW CORRECTION FACTORS - 20 TON					
CFM - ACTUAL	5760	6480	7200	7920	8640
TOTAL MBH	0.95	0.98	1.00	1.02	1.05
SENSIBLE MBH	0.90	0.95	1.00	1.05	1.10
POWER KW	0.98	0.99	1.00	1.01	1.02

FACTORY SETTING TURNS OPEN	
10 HP STD PULLEY	4
10 HP HIGH STATIC PULLEY	See NOTE

NOTE: High static pulleys are field installed and MUST be adjusted by the installing technician.

NOTES: 1) Multiply correction factor times gross performance data. 2) Resulting sensible capacity cannot exceed total capacity.

UNIT DIMENSIONS

ALL DIMENSIONS IN INCHES
DIMENSIONS FROM BASE LEVEL

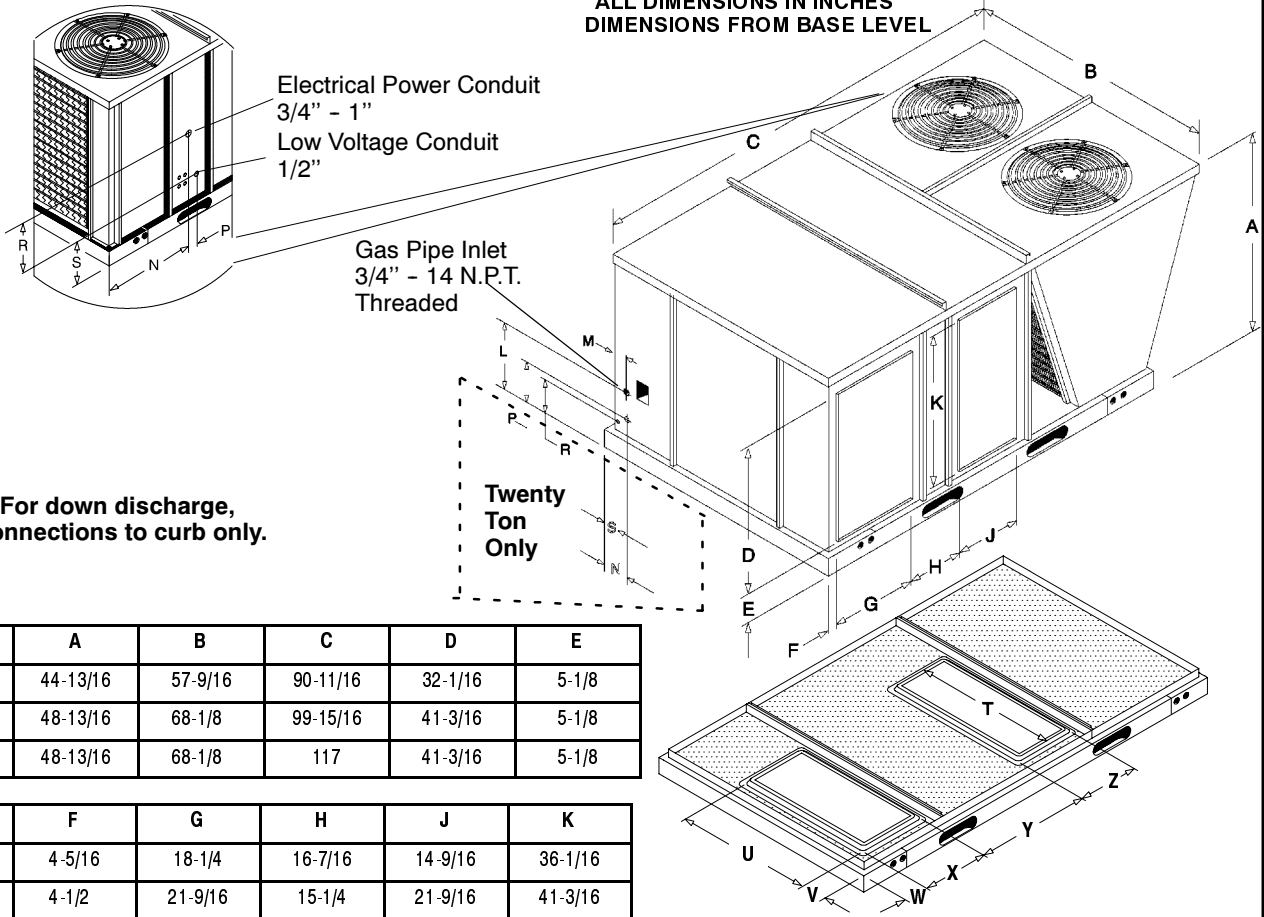

NOTE: For down discharge, duct connections to curb only.

Unit Size	A	B	C	D	E
7-1/2 & 10 Ton	44-13/16	57-9/16	90-11/16	32-1/16	5-1/8
12-1/2 & 15 Ton	48-13/16	68-1/8	99-15/16	41-3/16	5-1/8
20 Ton	48-13/16	68-1/8	117	41-3/16	5-1/8

Unit Size	F	G	H	J	K
7-1/2 & 10 Ton	4-5/16	18-1/4	16-7/16	14-9/16	36-1/16
12-1/2 & 15 Ton	4-1/2	21-9/16	15-1/4	21-9/16	41-3/16
20 Ton	4-1/2	21-9/16	15-1/4	21-9/16	41-3/16

Unit Size	L	M	N	P	R	S	T	U	V	W	X	Y	Z
7-1/2 & 10 Ton	9-1/8	4-1/4	32	9-1/4	15-1/2	9	39-1/8	35-1/16	3-1/2	3-1/2	21-3/16	12-7/8	17-1/2
12-1/2 & 15 Ton	14	5-1/2	31-15/16	9-1/4	15-1/2	9	45-1/16	45-1/16	3-1/2	3-1/2	24-1/2	11-13/16	24-1/2
20 Ton	14	5-1/2	6	8-1/4	7-1/8	2-3/4	45-1/16	45-1/16	3-1/2	3-1/2	24-1/2	11-13/16	24-1/2

ACCESSORIES

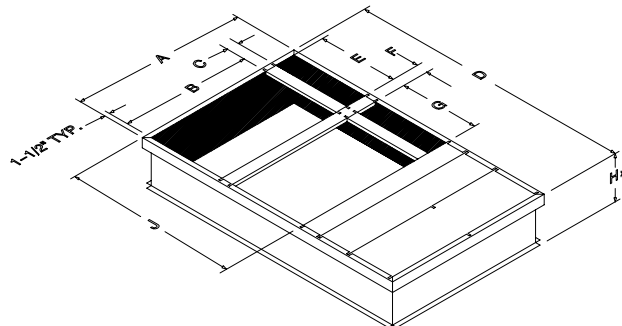

ROOF CURB DIMENSIONS

Model No.	Unit Size	A	B	C	D	E	F	G	H	J
AXB040C**	7-1/2 & 10 Ton	51	38-1/2	3-1/2	84-1/8	23-3/4	3-1/2	23-3/4	See below	52-1/2
AXB050C**	12-1/2 - 20 Ton	61-1/2	44	3-1/2	93-3/8	28-1/2	3-1/4	28-1/2	See below	61-3/4

* Roof Curbs come in 3 heights: Model # Letter L = 8", M = 14", H = 24"

ECONOMIZERS / DOWNFLOW (Use with 7 1/2 thru 20 Tons)

AXB040/050ECA (Entry Level - Three Position)

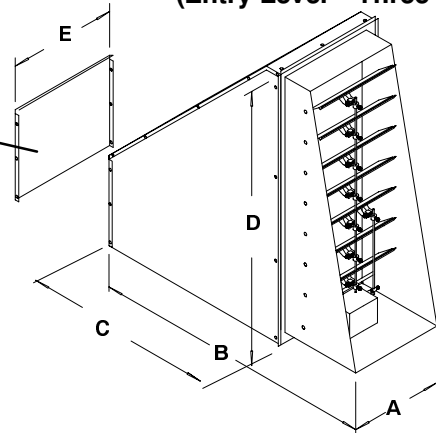
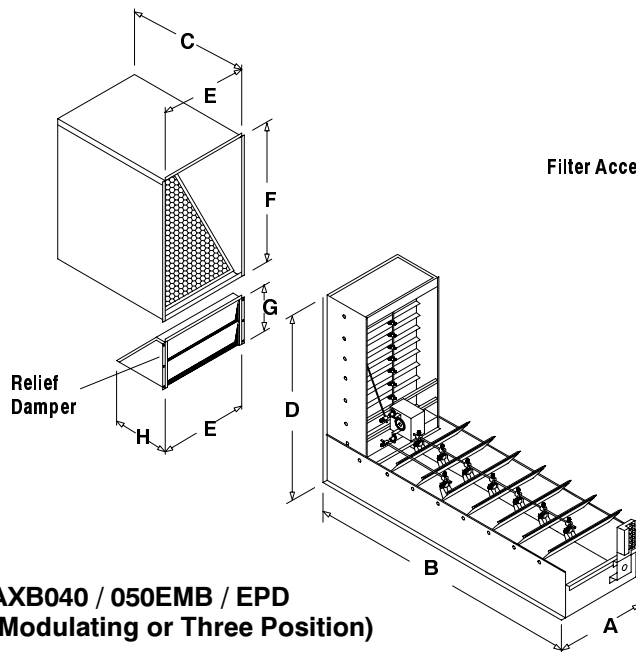

80-00-53

Model No.	A	B	C	D	E
AXB040ECA	12-7/16	37	26	37-3/8	14-7/16
AXB050ECA	18-1/2	37	26	42 1/2	21

ALL DIMENSIONS IN INCHES

AXB040 / 050EMB / EPD (Modulating or Three Position)

Model No.	A	B	C	D	E	F	G	H
AXB040E**	16 3/4	44-5/8	25 1/2	38 1/8	17-9/16	28-7/8	9-1/2	11 1/2
AXB050E**	23 3/4	56	25 1/2	41-3/4	23 11/16	31-3/4	9-1/2	11 1/2

Description	Model Number	Used on
Fully Modulating (1)	AXB040EMB	7 1/2 to 10 Ton
Three Position (2)	AXB040EPD	
Entry Level Three Position (3)	AXB040ECA	

Description	Model Number	Used on
Fully Modulating (1)	AXB050EMB	12 1/2 to 20 Ton
Three Position (2)	AXB050EPD	
Entry Level Three Position (3)	AXB050ECA	

NOTES:

- (1) - Ambient/Enthalpy Control; Includes Return Air Damper & Relief Damper.
 (2) - Ambient Control Only; Includes Return Air Damper & Relief Damper.
 (3) - Ambient Control Only; No Return Air Damper; No Relief Damper.

All Economizers Feature Enthalpy and/or ambient temperature control providing outdoor air ventilation and "free cooling" when outdoor conditions are favorable.

Return Air and Pressure Relief dampers for proper air balance, on most models.

Interconnecting wiring furnished.

Center controlled dual action dampers with gaskets to provide proper seal.

Description	Model Number	Used on
Fully Modulating (1)	AXB040HEB	7 1/2 to 10 Ton
Three Position (2)	AXB040HPD	

Description	Model Number	Used on
Fully Modulating (1)	AXB050HEB	12 1/2 to 20 Ton
Three Position (2)	AXB050HPD	

NOTES:

- (1) - Ambient/Enthalpy Control; Includes Return Air Damper & Relief Damper.
 (2) - Ambient Control Only; Includes Return Air Damper & Relief Damper.

ECONOMIZERS / HORIZONTAL

AXB040/50H**

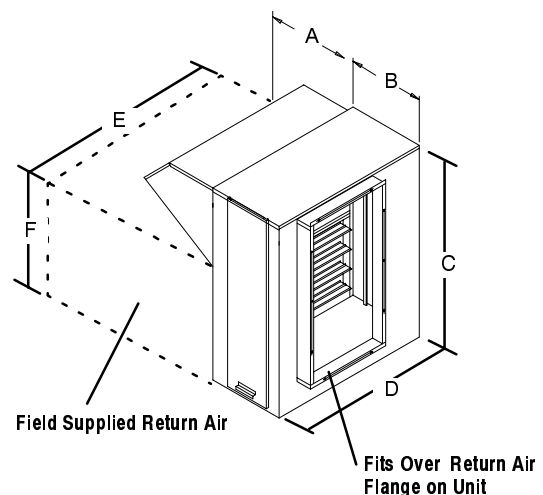

HORIZONTAL ECONOMIZER DIMENSIONS						
Model No.	A	B	C	D	E	F
AXB040	20-7/8	20-1/8	46-3/8	30-5/8	28-15/16	21-1/4
AXB050	20-7/8	20-1/8	50-3/8	42-1/2	40-13/16	21-1/4

ACCESSORIES (CONT...)

FOR DETAILED INFORMATION ON ACCESSORIES, SEE SYSTEM ACCESSORY GUIDE P.N. 401 10 1001 00.

ALL WEIGHTS ARE INSTALLED & IN POUNDS

ROOF CURBS

Description	Model Number / Weight	Used on
8"	AXB040CLA / 88	7 1/2 to 10 Ton
	AXB050CLA / 100	12 1/2 to 20 Ton
14"	AXB040CMA / 108	7 1/2 to 10 Ton
	AXB050CMA / 124	12 1/2 to 20 Ton
24"	AXB040CHA / 149	7 1/2 to 10 Ton
	AXB050CHA / 167	12 1/2 to 20 Ton

ECONOMIZERS - DOWNFLOW

Description	Model Number / Weight	Used on
Fully Modulating	AXB040EMB / 145	7 1/2 to 10 Ton
	AXB050EMB / 175	12 1/2 to 20 Ton
Three Position, no Return Air Damper	AXB040ECA / 120	7 1/2 to 10 Ton
	AXB050ECA / 140	12 1/2 to 20 Ton
Three Position, with Return Air Damper	AXB040EPC / 145	7 1/2 to 10 Ton
	AXB050EPC / 175	12 1/2 to 20 Ton

ECONOMIZERS - HORIZONTAL

Description	Model Number / Weight	Used on
Fully Modulating	AXB040HEB / 214	7 1/2 to 10 Ton
	AXB050HEB / 250	12 1/2 to 20 Ton
Three Position	AXB040HPC / 214	7 1/2 to 10 Ton
	AXB050HPC / 250	12 1/2 to 20 Ton

PART NUMBERS FOR APPROVED HIGH STATIC CONVERSIONS *

Unit Size	Motor	Motor Pulley	Blower Pulley	Belt
7 1/2 Ton	No Change	1071319	No Change	No Change
10 Ton	1070646	1071718	No Change	No Change
12 1/2 Ton	1071520	521096	1071737	1071738
15 Ton	1071520	521096	1071737	1071738
20 Ton	No Change	1082350 (IVP650)	No Change	No Change

* Available through Service Parts

OUTDOOR AIR DAMPERS

Description	Model Number / Weight	Used on
Manual 0- 25%	AXB040FAB / 12	7 1/2 to 10 Ton
	AXB050FAB / 26	12 1/2 to 20 Ton
Motorized- 25%	AXB040FMB / 27	7 1/2 to 10 Ton
	AXB050FMB / 41	12 1/2 to 20 Ton

LOW AMBIENT CONTROLS *

Description	Model Number - Weight	Used on
To 0° F	1071675 / 3	7 1/2 to 15 Ton
To 0° F	1082357 / 5	20 Ton

COIL PROTECTION *

Description	Model Number	Used on
Coil Guard	AXB040GCB	7 1/2 to 10 Ton
	AXB050GCB	12 1/2 to 15 Ton
Hail Guard	AXB040GHB	7 1/2 to 10 Ton
	AXB050GHB	12 1/2 to 15 Ton

* Available through Service Parts

FOSSIL FUEL CONVERSION

Description	Model Number	Used on
Natural to LP Gas	1071350	200 - 270 MBTUH
LP to Natural Gas	1071353	200 - 270 MBTUH

CONCENTRIC DUCT KITS

Description	Model Number / Weight	Used on
Square to Round	AXB040CTA ** / 25	7 1/2 Ton

** Includes two square to round boxes. Units over 7 1/2 Ton use rectangular duct connections to the concentric grilles and do not require transition accessory.

CONCENTRIC DIFFUSER (FLUSH MOUNT)

Description	Model Number / Weight	Used on
Concentric Diffuser (F.M.)	AXB040CFA / 55	7 1/2 Ton
Concentric Diffuser (F.M.)	AXB045CFA / 165	10 Ton
Concentric Diffuser (F.M.)	AXB050CFA / 190	12 1/2 Ton
Concentric Diffuser (F.M.)	AXB055CFA / 235	15 Ton
Concentric Diffuser (F.M.)	AXB058CFA / 335	20 Ton

CONCENTRIC DIFFUSER (STEP DOWN)

Description	Model Number / Weight	Used on
Concentric Diffuser (S.D.)	AXB040CSA / 180	7 1/2 Ton
Concentric Diffuser (S.D.)	AXB045CSA / 185	10 Ton
Concentric Diffuser (S.D.)	AXB050CSA / 247	12 1/2 Ton
Concentric Diffuser (S.D.)	AXB055CSA / 260	15 Ton
Concentric Diffuser (S.D.)	AXB058CSA / 360	20 Ton

NOTES

GUIDE SPECIFICATION

CABINET

The cabinet shall be made of sturdy G-90 galvanized steel, phosphate coated with an epoxy based primer and polyester finish coat for long lasting weatherproof construction. Base rails shall be made of 16 gauge steel and have fork lift slots plus holes provided for lifting shackles. Unit shall be designed with convertible airflow and are shipped ready for downflow applications with conversion to horizontal airflow being accomplished by relocating two panels. The indoor blower compartment interior cabinet surfaces shall be insulated with a minimum 1/2" thick, flexible glass fiber insulation, coated on the air side. Aluminum foil faced glass fiber insulation shall be used in the furnace compartment.

COOLING SECTION

Units shall be factory charged and operationally ready upon delivery. The unit shall have two independent refrigerant systems providing two stage cooling operation. Each refrigerant circuit shall have a high efficiency, fully hermetic compressor with internal overload protection, high and low pressure switches, filter drier, and copper tube / aluminum fin evaporator and condenser coils. The unit shall be designed for two-stage cooling operation down to 40° F. as shipped, as well as pre-wired for economizer-type accessories.

COILS

The evaporator and condenser coils shall be fabricated with aluminum fins mechanically bonded to copper tubing. Both coils shall be pressure tested prior to assembly into the unit and electronically leak tested after assembly into the unit. The evaporator coil shall be protected from dust and debris on the return air side by factory installed 2" low velocity glass fiber air filters. Filter face velocity shall not exceed 220 FPM for 7-1/2 ton units, 290 FPM for the 10 ton units, 365 FPM for the 12-1/2 ton units, 440 FPM for the 15 ton units and 480 FPM for the 20 ton at nominal airflows.

CONDENSER FAN(S)

The 7-1/2 ton units shall have a single direct-drive propeller-fan/motor assembly; the 10 thru 20 ton units shall have two condenser fan assemblies. The assemblies shall be mounted directly to a vertical-discharge grille that is easily removable for service. Motors shall be rated at 1100 RPM and shall have permanently lubricated ball bearings and internal overload protection.

EVAPORATOR BLOWER

The 7-1/2 thru 20 ton units shall have a single belt driven evaporator blower (56 frame) and it shall have permanently lubricated ball bearings and internal overload protection. An adjustable motor drive sheave for matching air flow requirements shall be standard. Additionally, high static kits shall be available for air flows above the standard requirement. The external static capability of the unit shall be the same for horizontal and downflow discharge.

HEATING SECTION

The units shall have aluminized steel tubular heat exchangers located on the discharge side of the evaporator blower and equipped with a two stage gas valve. The units shall have in-shot burners that are ignited by an electronic spark with flame proving feature and protected by both a limit switch and flame roll-out switch. The induced draft blower shall have a two-speed motor and shall be interlocked with a proven air pressure safety device.

INSTALLATION CLEARANCES

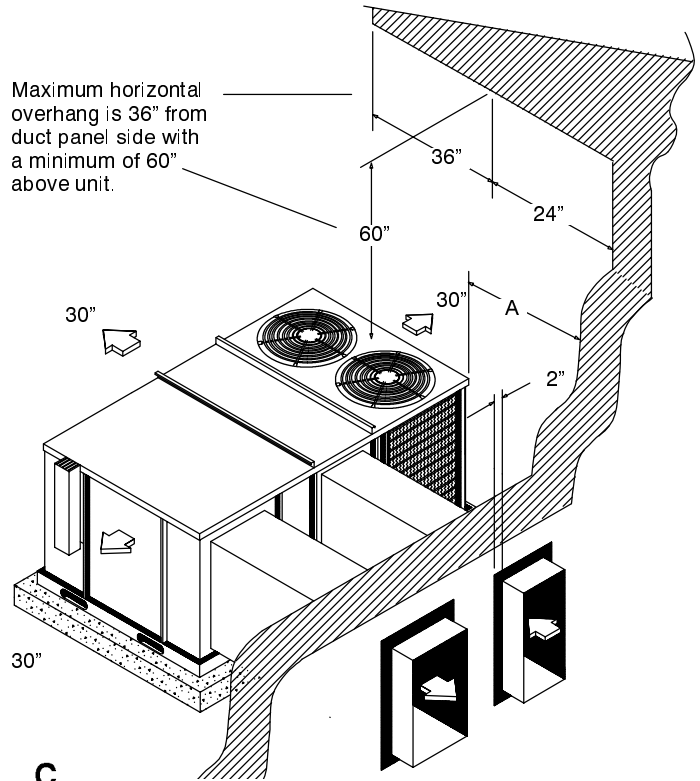

A = 24" with no economizer; 48" with economizer;
On 20 ton models, 30" is suggested to allow adequate compressor service clearance.

RIGGING DETAILS

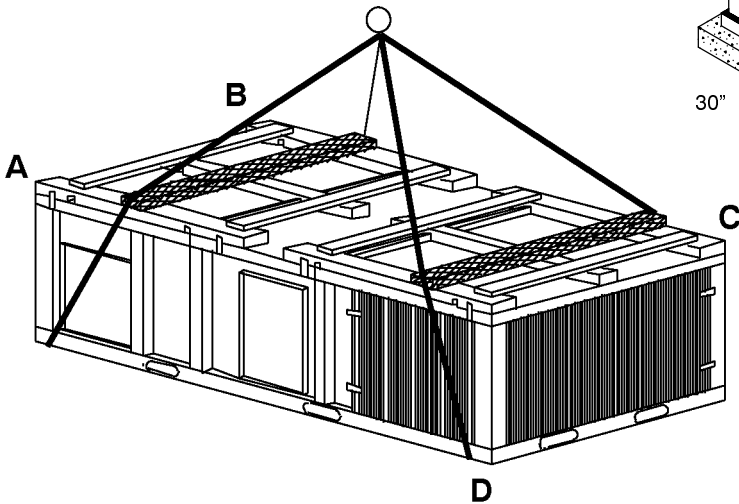

CORNER WEIGHTS (LBS)

UNIT SIZE (Ton)	A	B	C	D	OPERATING WEIGHT TOTAL
7-1/2	222	317	316	220	1,075
10	232	332	330	231	1,125
12-1/2	253	362	359	251	1,225
15	264	376	373	262	1,275
20	300	400	500	500	1,850