

PAS SERIES

25 Ton Specification

Arcoaire[®]
Air Conditioning & Heating

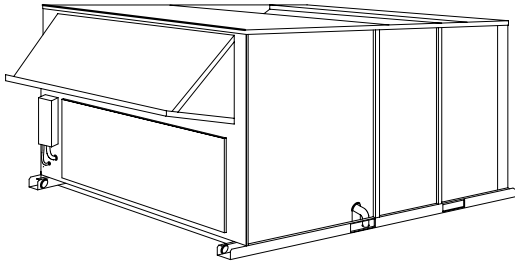

PAS300



Commercial Package Air Conditioner Units

REFRIGERATION CIRCUIT

- Each unit features two independent refrigerant circuits with a scroll compressor on each circuit. Refrigerant metering devices for each circuit are TXVs.
- Two stage cooling.
- Compressor protection includes high and low-pressure cutouts and over-temperature protection.
- Units are prewired and precharged with R-22 at the factory.
- Dual freezestat protection.
- Liquid line filter driers.
- Low outdoor temperature cooling operation to 40° F is standard.

BUILT TO LAST

- Cabinet made of pre-painted, baked enamel finish and insulated with neoprene-coated fiberglass.
- Commercial strength base rails with built-in rigging capability.
- Non-corrosive, sloped condensate drain pan, meets ASHRAE 62-89.
- Condenser fan motors are internally protected.
- Control circuit protected by circuit breaker.
- Units are factory tested in both heating and cooling modes.
- Warranty: Five year warranty on the compressors, One year warranty on parts

EASY TO INSTALL AND SERVICE

- Combination electric cooling and electric heat, self contained for year-round comfort. Unit shipped ready for downflow applications with conversion to horizontal airflow accomplished with accessory horizontal discharge roof curb.
- Single point electrical service entry.
- Horizontal supply available with adapter roof curb accessory. Power exhaust and barometric relief must be external to unit if used with horizontal supply/return.
- Manually adjustable outside air intake for up to 25% outside air.
- Adjustable speed main blower drives.
- Tool-less removal for filter access with two inch disposable-type fiberglass return air filters.

RESIDENTIAL AND COMMERCIAL SYSTEMS • SPLIT SYSTEMS • PACKAGED AIR CONDITIONERS • COMBINATION GAS / ELECTRIC UNITS • HEAT PUMPS • AIR HANDLERS • MANUFACTURED HOME AIR CONDITIONERS • GAS, OIL AND ELECTRIC FURNACES

International Comfort Products
650 Heil-Quaker Avenue, Lewisburg, TN 37091

513 31 2202 00

7/21/05

Table of Contents

	Page
Features/Benefits	1
Model Number Nomenclature	2
Unit Specifications	3-4
Dimensions	5
Performance Data	6-8
Typical Installation	9
Accessories	10-13
Controls and Application Data	14
Guide Specifications	14

MODEL NUMBER IDENTIFICATION GUIDE							
MODEL NUMBER	P	A	S	300	H	000	B
PRODUCT FAMILY Package Units							Sales Code
TYPE H= Heat Pump G = Gas/Electric A = Air Conditioner							Gas Heat OPTIONS 000 = No Heat
							VOLTAGE / PHASE / HERTZ H = 208/230-3-60 L = 460-3-60
DESIGN SERIES Standard Efficiency							COOLING CAPACITY (NOMINAL BTUH) 300 = 25 Ton

UNIT SPECIFICATIONS - MODELS			
COOLING	PAS300H00B	PAS300L00B	PAS300S00B
ARI Rated Capacity Btuh (Net)	270,000		
Nominal Tons	25		
Standard CFM	10,000		
EER	8.7		
IPLV	9.2		
Sound Rating (Bels)	9.4		
Base Unit Operating Weights (lbs)	1850		
ELECTRICAL			
Volts/ 3 Phase/ 60Hertz	208/230	460	575
Voltage Range Min/Max	187 / 253	414 / 506	518 / 632
Power Supply MCA	134 / 134	66	55
Power Supply MOCP*	175 / 175	80	70
COMPRESSOR	SCROLL / Maneurop		
Quantity...Model	1...SM161 / 1...SM120		
No. of Circuits	2		
RLA / LRA Circuit #1	47.5 / 265	22.9 / 145	17.9 / 102
Circuit #2	33.0 / 237	16.2 / 130	12.7 / 185
Oil (Oz.) per circuit	CKT 1 = 112, CKT 2 = 110		
REFRIGERATION TYPE	R-22		
Expansion Device	TXV		
Operating Charge (lb. oz.) **	CKT 1 = 21-0 CKT 2 = 15-4		
CONDENSER FAN	Propeller Type		
Nominal CFM	12,500		
Quantity..Diameter (in.)	2...30		
Motor Hp...RPM (each)	1...1075		
Watts Input (Total)	3400		
FLA	6.6	3.3	3.4
CONDENSER COIL	Cross Hatched 3/8 in. Copper Tubes, Aluminum		
Rows...Fin/In.	4...15		
Total Face Area (Sq. Ft.)	21.7		
EVAPORATOR COIL	Cross Hatch 3/8 in. Copper Tubes, Aluminum Lanced, Face Split		
Rows...Fins/Inche	4...15		
Total Face Area (sq. ft.)	17.5		
EVAPORATOR FAN	Centrifugal Type		
Quantity...Size (in.)	2...12 x 12		
Type Drive	Belt		
Nominal CFM	10,000		
Motor Hp, RPM, Max. Continuous Bhp	10.0, 1740, 10.2	10.0, 1740, 11.8	10.0, 1740, 10.2
FLA (Each)	28.0	14.6	13.0
Motor Frame Size	215T		
Fan RPM Range	1066-1283		
Motor Bearing	Ball		
Maximum Allowable RPM	1550		
Motor Pulley Pitch / Diameter Min/Max. (in.)	4.9 - 5.9		
Motor Shaft Diameter (in.)	1-3/8		
Fan Pulley Pitch Diam (in)	8.0		
Belt, Quantity...Type... Length (in.)	2.BX.50		
Pulley Center Line Distance (in)	14.6-15.4		
Speed Change per Full Turn of Movable Pulley Flange (RPM)	36		
Pulley Max. full Turns From Closed Postion	5		
Factory Setting	3.5		
Factory Speed Setting RPM	1182		
Fan Shaft Diam. at Pulley	1-7/16		
SEE LEGENDS AND NOTES ON FOLLOWING PAGES			

UNIT SPECIFICATIONS (CONT)	MODELS
HIGH-PRESSURE SWITCH (psig)	PAS300H/L/S
Internal Relief (Differential) Cutout	426
Reset (Auto.)	320
LOSS-OF-CHARGE SWITCH (psig) (LOW-PRESS.)	
Cutout	27
Reset (Auto.)	44
FREEZE PROTECTION THERMOSTAT (F)	
Opens	30 +/- 5
Closes	45 +/- 5
RETURN-AIR FILTERS (THROW-AWAY)	
Quantity...Size (in.)	4...20 x 20 x 2
	4...16 x 20 x 2

LEGENDS AND NOTES

LEGEND

Bhp = Brake Horsepower	
Bels	- Sound Levels
EER	- Energy Efficiency Ratio
IPLV	- Integrated Part Load Values
MCA	- Minimum Circuit Amps
MOCP	- Maximum Over-current Protection
FLA	- Full Load Amps
LRA	- Locked Rotor Amps
RLA	- Rated Load Amps

* Fuse or HACR circuit breaker

**Circuit 1 uses the lower portion of the condenser coil and lower portion of the evaporator coils; and Circuit 2 uses the upper portion of both coils. +Rollout switch is manual reset.

NOTE: The PAS300 units have a low-pressure switch (standard) located on the suction side.

NOTE: Minimum allowable temperature of mixed-air entering the heat exchanger during first-stage heating is 45F. There is no minimum mixed-air temperature limitation during second-stage heating. For entering-air temperatures below 45 F both stages of heat must be energized together to minimize condensation issues and ensure proper unit operation.

NOTES:

1. In compliance with NEC requirements for multimotor and combination load equipment (refer to NEC Articles 430 and 440), the over-current protective device for the unit shall be fuse or HACR breaker. Canadian units may be fuse or circuit breaker.

2. Unbalanced 3-Phase Supply Voltage

Never operate a motor where a phase imbalance in supply voltage is greater than 2%. Use the following formula to determine the percent voltage imbalance.

% Voltage Imbalance

$$= 100 \times \frac{\text{max voltage deviation from average voltage}}{\text{average voltage}}$$

NOTES: 1. Ratings are based on:

Cooling Standard: 80F db, 67F wb indoor entering air temperature and 95F db air entering outdoor unit.

IPLV Standard: 80F db, 67F wb indoor entering air temperature and 80F db entering air temperature.

NOTE: PAS300 is beyond the scope of ARI Certification Program.

EXAMPLE: Supply voltage is 460-3-60.

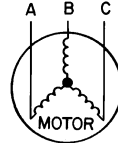

$$\begin{aligned} AB &= 452 \text{ v} & \text{Average Voltage} &= \frac{452 + 464 + 455}{3} \\ BC &= 464 \text{ v} & &= \frac{1371}{3} \\ AC &= 455 \text{ v} & &= 457 \end{aligned}$$

Determine maximum deviation from average voltage.

$$(AB) 457 - 452 = 5 \text{ V}$$

$$(BC) 464 - 457 = 7 \text{ V}$$

$$(AC) 457 - 455 = 2 \text{ V}$$

Maximum deviation is 7 v.

Determine percent voltage imbalance.

$$\% \text{ Voltage Imbalance} = 100 \times \frac{7}{457} = 1.53\%$$

This amount of phase imbalance is satisfactory as it is below the maximum allowable 2%.

IMPORTANT: If the supply voltage phase imbalance is more than 2%, contact your local electric utility company immediately.

PAS300 BASE UNIT DIMENSIONS

Unit Size	Total Weight		Corner A		Corner B		Corner C		Corner D		Dim A		Dim B		Dim C	
	lb	kg	lb	kg	lb	kg	lb	kg	lb	kg	inches	mm	inches	mm	inches	mm
PAS300	1850	839	419	190	421	191	503	228	507	230	38	963	43	1090	20	508

1. Dimensions in () are in millimeters.

2. Center of Gravity.

3. Direction of Airflow

4. Ductwork to be attached to accessory roof curb only.

5. Minimum clearance:

- Rear: 7'-0" (2134) for coil removal. This dimension can be reduced to 4'0" (1219) if conditions permit coil removal from the top.
- 4'0" (1219) to combustible surfaces, all four sides (includes between units).
- Left Side: 4'-0" (1219) for proper condenser coil airflow.
- Front: 4'-0" (1219) for control box access.
- Right side: 4'-0" (1219) for proper operations of damper and power exhaust if so equipped.
- Top: 6'-0" (1829) to assure proper condenser fan operation.
- Bottom: 14" (356) to combustible surfaces (when not using curb).
- Control Box side: 3'-0" (914) to ungrounded surfaces, non-combustible
- Control Box Side: 3'-6" (1067) to block or concrete walls, or other grounded surfaces.
- Local codes or jurisdiction may prevail.

6. With the exception of clearance for the condenser coil as stated in Note 5, a removable fence or barricade requires no clearance.

7. Dimensions are from outside of corner post. Allow 0'-5/16" on each side for top cover drip edge.

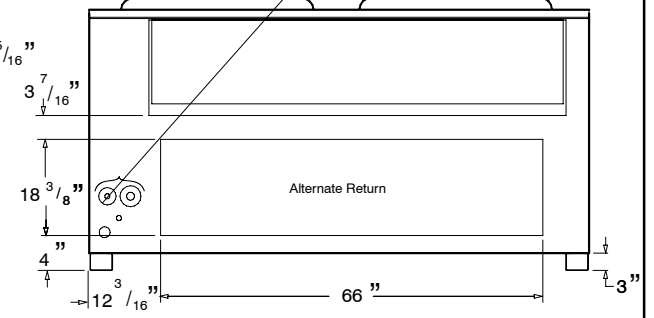
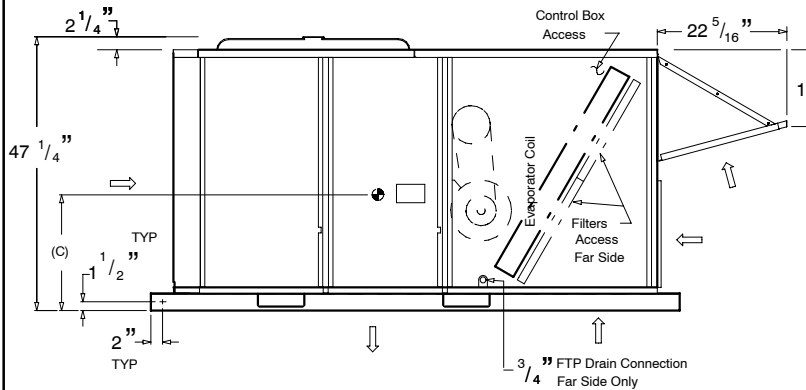
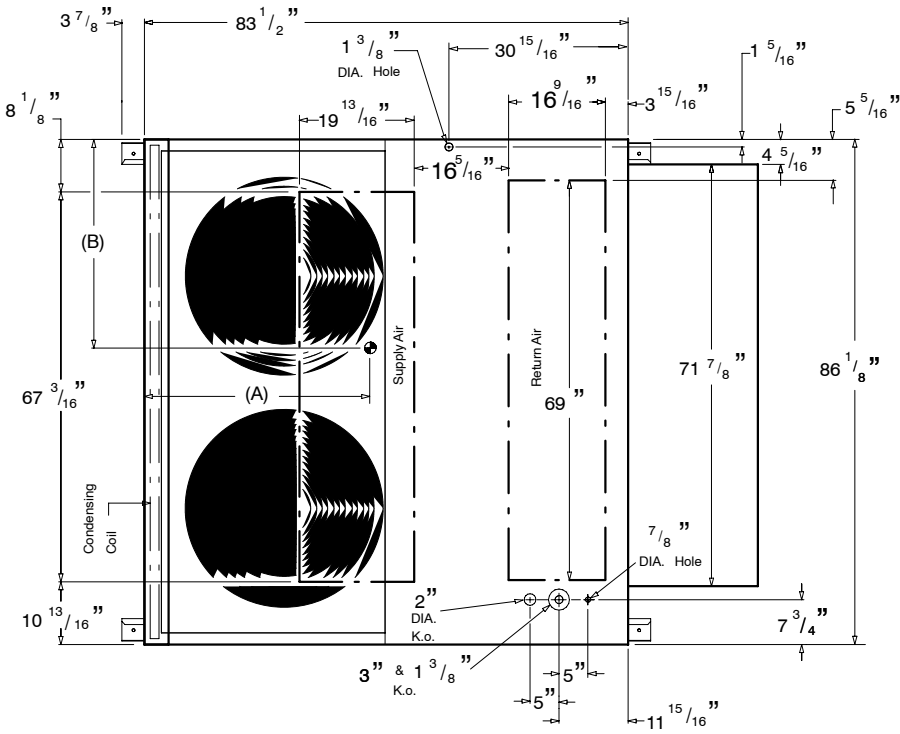
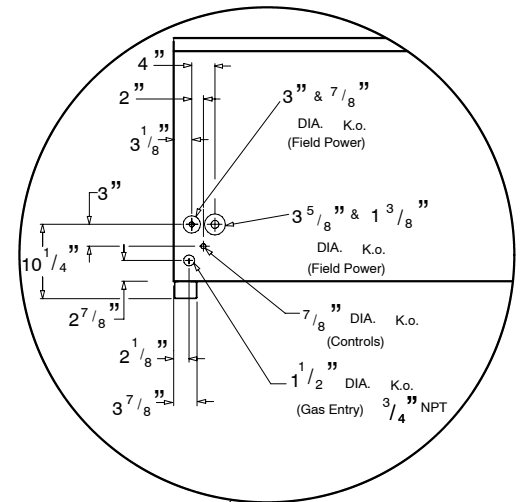
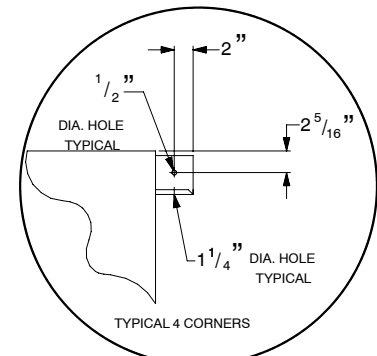

38-11-38

EXPANDED PERFORMANCE DATA (COOLING) 25 TON (GROSS CAPACITY)

Temp (F) Air Entering Condenser (Edb)		Evaporator Air Quantity - CFM													
		8,000							9,000						
		Evaporator Air - Ewb (F)/BF													
		54/0.49	58/0.32	62/0.15	67/0.14	72/0.13	76/0.17	80/0.00	54/0.53	58/0.37	62/0.18	67/0.15	72/0.14	76/0.17	80/0.00
75	TC	266	268	280	304	324	352	379	277	276	286	310	336	361	385
	SHC	266	251	246	209	168	137	107	277	269	261	221	178	142	108
	kW	19.5	19.6	19.9	20.5	20.9	21.8	22.4	19.8	19.5	20.0	20.6	21.3	22.0	22.6
85	TC	260	262	272	294	321	344	367	271	272	277	300	326	349	373
	SHC	260	254	243	205	167	135	104	271	264	257	217	175	139	104
	kW	21.6	21.6	22.0	22.5	23.3	23.9	24.6	22.2	21.9	22.1	22.7	23.4	24.1	24.8
95	TC	254	256	262	284	310	332	355	263	263	268	289	316	337	360
	SHC	254	249	238	201	163	131	100	263	263	251	213	171	135	100
	kW	23.8	23.9	24.1	24.8	25.5	26.2	26.9	24.1	24.1	24.3	24.9	25.9	26.4	27.1
105	TC	246	247	253	274	298	319	343	255	255	258	278	302	326	346
	SHC	246	245	233	197	159	127	96	255	255	246	208	166	132	96
	kW	26.3	26.3	26.5	27.2	28.0	28.7	29.5	26.5	26.5	26.6	27.3	28.1	29.0	29.6
115	TC	238	239	243	264	286	306	328	247	246	249	267	290	311	-
	SHC	238	239	228	193	155	123	91	247	246	239	204	162	127	-
	kW	28.9	28.9	29.1	29.7	30.6	31.4	32.1	29.1	29.2	29.3	30.0	30.8	31.5	-

EXPANDED PERFORMANCE DATA (COOLING) 25 TON (GROSS CAPACITY) Cont.

Temp (F) Air Entering Condenser (Edb)		Evaporator Air Quantity - CFM													
		10,000							11,250						
		Evaporator Air - Ewb (F)/BF													
		54/0.57	58/0.41	62/0.23	67/0.16	72/0.15	76/0.17	80/0.00	54/0.61	58/0.47	62/0.30	67/0.16	72/0.17	76/0.17	80/0.00
75	TC	286	284	291	314	341	365	390	295	295	298	319	342	367	392
	SHC	286	284	274	232	186	147	108	295	295	285	245	193	151	108
	kW	20.0	20.2	20.2	20.8	21.5	22.1	22.7	20.3	20.3	20.4	20.9	21.2	21.5	21.9
85	TC	278	278	282	304	330	354	378	288	287	289	310	334	359	384
	SHC	278	278	269	228	182	143	105	288	287	278	241	190	148	106
	kW	22.1	22.1	22.2	22.8	23.6	24.2	24.9	22.5	22.4	22.4	23.1	23.7	24.4	25.3
95	TC	270	270	273	293	319	341	364	278	278	280	318	323	346	-
	SHC	270	270	262	223	177	139	101	278	278	269	150	186	144	-
	kW	24.4	24.4	24.4	25.1	25.8	26.5	27.2	24.6	24.6	24.7	30.0	26.0	26.7	-
105	TC	261	262	264	282	306	328	352	269	269	272	285	310	332	-
	SHC	261	262	254	219	173	135	97	269	269	259	232	182	140	-
	kW	26.8	26.8	26.9	27.5	28.3	29.0	29.8	27.0	27.0	27.1	27.6	28.4	29.1	-
115	TC	253	253	255	270	293	315	-	259	260	262	273	297	318	-
	SHC	253	253	245	214	168	131	-	259	260	247	227	177	136	-
	kW	29.3	29.3	29.6	30.1	30.9	31.7	-	29.7	29.6	29.8	30.2	31.1	31.8	-

FORMULAS AND NOTES FOR USING EXPANDED PERFORMANCE DATA

LEGEND

- BF - Bypass Factor
- Edb - Entering Dry-Bulb
- Ewb - Entering Wet-Bulb
- kW - Compressor Motor Power Input
- ldb - Leaving Dry-Bulb
- lwb - Leaving Wet-Bulb
- SHC - Sensible Heat capacity (1000 Btuh) Gross
- TC - Total Capacity (1000 Btuh) Gross

1. Direct interpolation is permissible. Do not extrapolate.
2. The following formulas may be used:
 - $t /ldb = t edb - \text{sensible capacity (Btuh)} / (1.10 \times \text{cfm})$
 - $t /wb = \text{Wet bulb temp. corresponding to enthalpy of air leaving evaporator coil (h/wb)}$
 - $h /wb = h web - \text{total capacity Btuh} / (4.5 \times \text{cfm})$
where h ewb = Enthalpy of air entering evap. coil.

3. The SHC is based on 80 F edb temperature of air entering evaporator coil.
Below 80 F edb, subtract (corr factor x cfm) from SHC.
Above 80 F edb, add (corr factor x cfm) to SHC,

Bypass Factor (BF)	ENTERING AIR DRY-BULB TEMP (F)						Use Formula Below
	79	78	77	76	75	under 75	
	81	82	83	84	85	over 85	
Correction Factor							
0.05	1.04	2.07	3.11	4.14	5.18		
0.10	0.98	1.96	2.94	3.92	4.91		
0.20	0.87	1.74	2.62	3.49	4.36		
0.30	0.76	1.53	2.29	3.05	3.82		
0.40	0.65	1.31	1.96	2.62	3.27		
0.50	0.55	1.09	1.64	2.18	2.73		
0.60	0.44	0.87	1.31	1.74	2.18		
0.70	0.33	0.65	0.98	1.31	1.64		

Interpolation is permissible.
Correction factor = $1.10 \times (1 - BF) \times (edb - 80)$.

CIRCULATING BLOWER PERFORMANCE - 25 TON (10.0 HP Standard Motor)

CFM	External Static Pressure in Inces Water Column - Dry coil With Filter																	
	0.2		0.4		0.6		0.8		1.0		1.2		1.4		1.6		1.8	
	RPM	W	RPM	W	RPM	W	RPM	W	RPM	W	RPM	W	RPM	W	RPM	W	RPM	W
7000	845	2693	909	2979	969	3272	1028	3574	1083	3883	1137	4200	1169	4524	1239	4854	1288	5191
7500	896	3156	956	3450	1014	3752	1069	4060	1123	4375	1174	4698	1224	5026	1272	5362	1320	5703
8000	948	3667	1005	3969	1060	4278	1112	4593	1163	4915	1213	5243	1261	5577	1307	5917	1353	6263
8500	1001	4226	1054	4537	1106	4853	1156	5175	1205	5504	1253	5838	1299	6177	1344	6523	1388	6873
9000	1053	4836	1104	5155	1154	5478	1202	5808	1248	6142	1294	6483	1338	6828	1382	7179	1424	7534
9500	1106	5498	1155	5824	1202	6155	1248	6492	1293	6833	1336	7179	1379	7530	1421	7887	1462	8247
10000	1159	6214	1206	6547	1251	6886	1295	7229	1338	7577	1380	7929	1421	8286	1461	8648	1501	9014
10500	1213	6984	1257	7325	1300	7671	1342	8020	1384	8375	1424	8733	1464	9096	1503	9464	1541	9835
11000	1266	7810	1309	8159	1350	8511	1391	8868	1431	9229	1470	9594	1508	9963	1546	10336	-	-
11250	1293	8245	1334	8597	1375	8953	1415	9313	1454	9677	1493	10045	1530	10417	-	-	-	-

W = Watts

NOTES:

1. Maximum continuous bhp is 10.20 (208/230, 575 v) or 11.80 (460 v) and the maximum continuous watts are 9510 (208/230, 575 v) or 11,000 (460 v). Do not adjust motor rpm such that motor maximum bhp and/or watts is exceeded at the maximum operating cfm.

PERFORMANCE DATA (cont.)

HORIZONTAL SUPPLY/RETURN FAN PERFORMANCE WITH HIGH STATIC REGAIN ADAPTER CURB

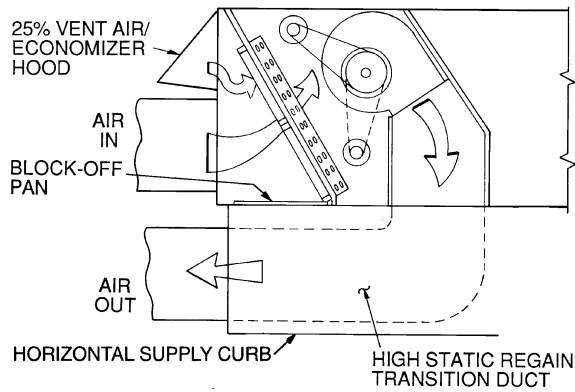

NOTE: The high static regain adapter accessory may be used to provide horizontal supply//return.

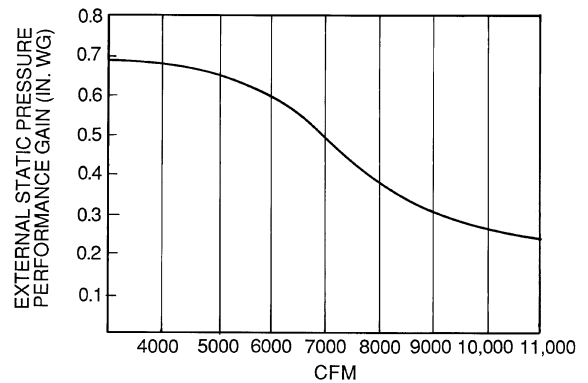

NOTE: The high static supply/return adapter accessory improves fan performance by increasing external static pressure by amount shown above.

Evaporator Fan Motor Efficiency

UNIT	MOTOR EFFICIENCY (%)
PAS300 (10.0 Hp)	89.5

Performance Data (Cont.)

AIR QUANTITY UNITS		
Unit Size	Minimum CFM	Maximum CFM
PAS300	7,500	12,500

OUTDOOR SOUND POWER										
UNIT	SOUND RATING (60Hz)	A - Weighted (db)	OCTAVE BANDS							
			63	125	250	500	1000	2000	4000	8000
PAS300	9.4 Bels	94.1	98.7	92.3	93.8	90.9	89.6	85.9	80.3	74.3

Bels - Sound Levels (1 bel = 10 decibels).

FAN RPM AT MOTOR PULLEY SETTINGS *													
UNIT	MOTOR PULLEY TURNS OPEN												
	0	1/2	1	1-1/2	2	2-1/2	3	3-1/2	4	4-1/2	5	5-1/2	6
PAS300	**	**	1283	1269	1247	1225	1203	1182	1160	1138	1116	1095	1066

* Approximate fan rpm shown.

** Due to belt and pulley size, pulley cannot be set to this number of turns open.

EVAPORATOR FAN MOTOR PERFORMANCE					
UNIT	Unit Voltage	Maximum Acceptable Continuous BHP*	Maximum Acceptable Continuous BkW*	Maximum Acceptable Operating Watts	Maximum Amp Draw
PAS300	208/230	10.20	7.61	9,510	28.0
	460	11.80	8.80	11,000	14.6
	575	10.20	7.61	9,510	13.0

Bhp - Brake Horsepower.

* Extensive motor and electrical testing on these units ensures that the full horsepower range of the motors can be utilized with confidence. Using your fan motors up to the horsepower ratings shown in this table will not result in nuisance tripping or premature motor failure. Unit warranty will not be affected.

Note: All indoor fan motors 5 hp and larger meet the minimum efficiency requirements as established by the Energy Policy Act of 1992 (EPACT) effective October 24, 1997.

TYPICAL INSTALLATIONS

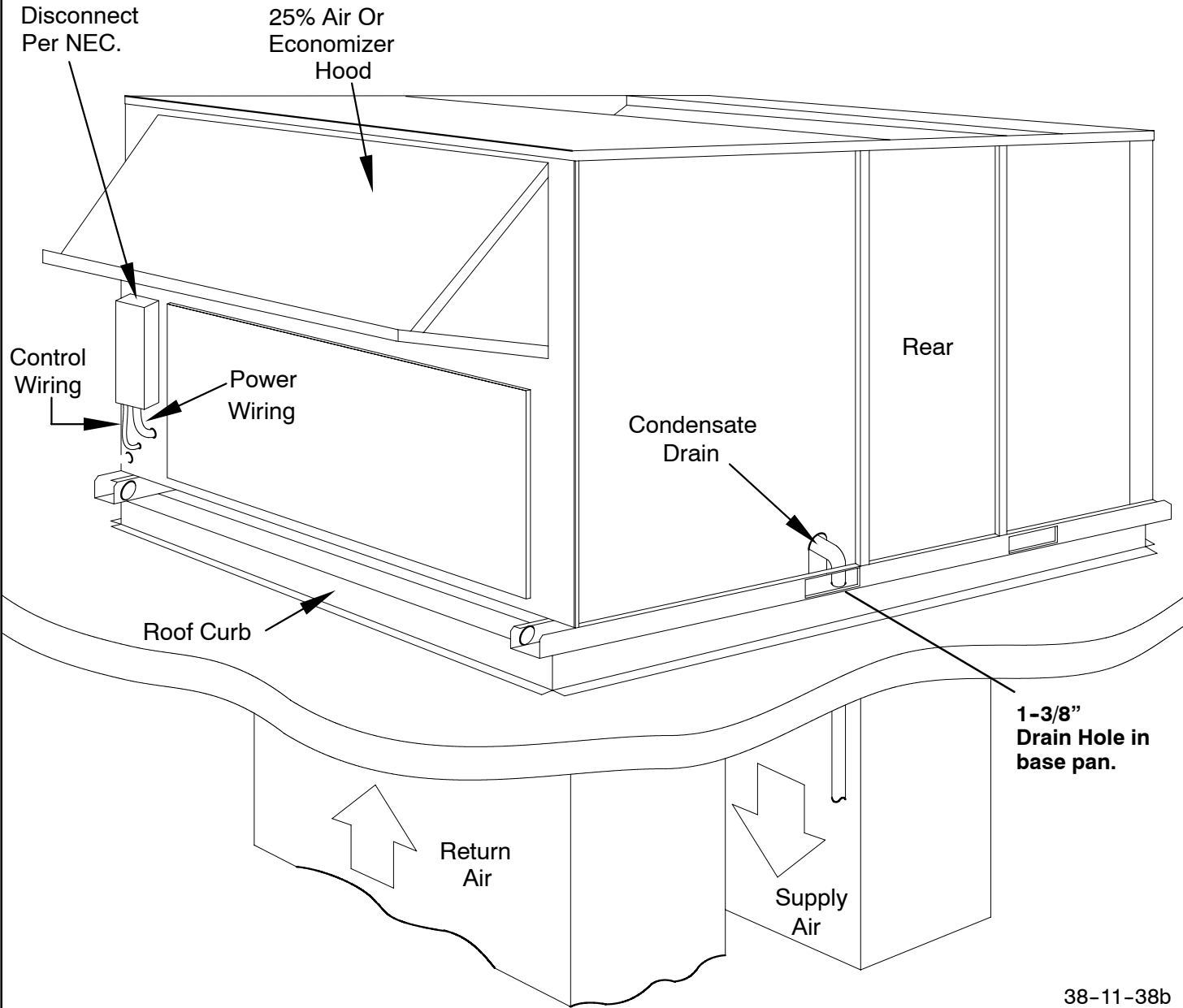

38-11-38b

CLEARANCES: See Page 5

ACCESSORIES

VERTICAL DISCHARGE ROOF CURBS

Description	Model Number	Where Used
14" High	AXB060CMA	25 Ton
24" High	AXB060CHA	25 Ton

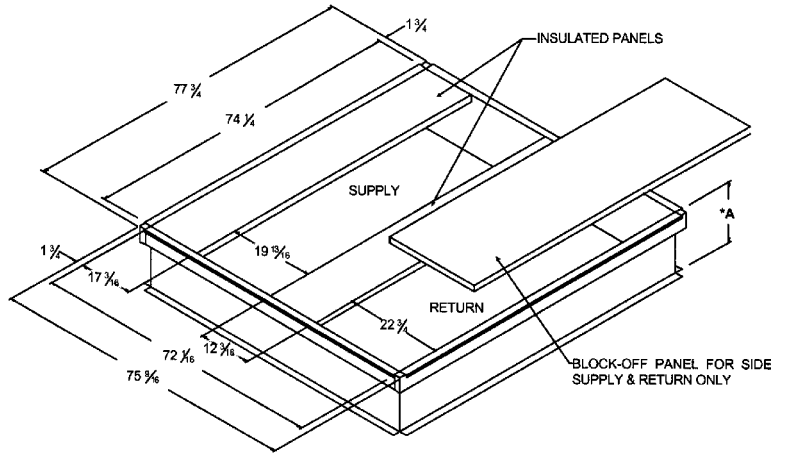

HORIZONTAL DISCHARGE ROOF CURBS

Description	Model Number	Where Used
24" High	AXB065CHA	25 Ton
24" High w/ Duct	AXB165CHA	25 Ton

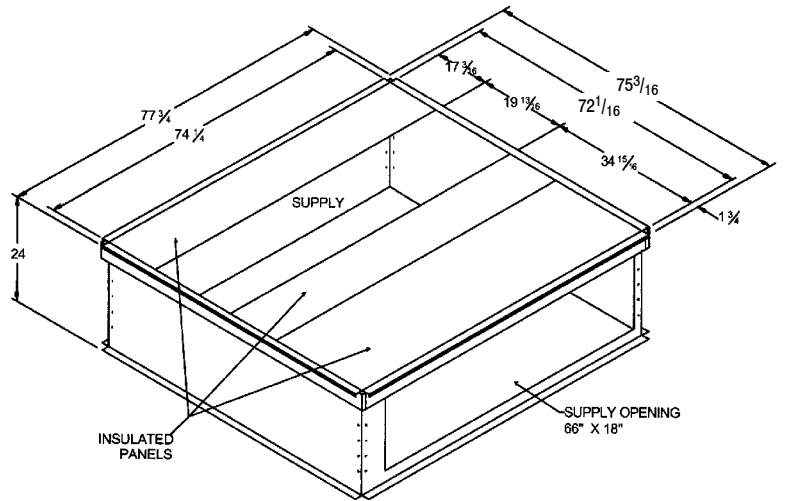
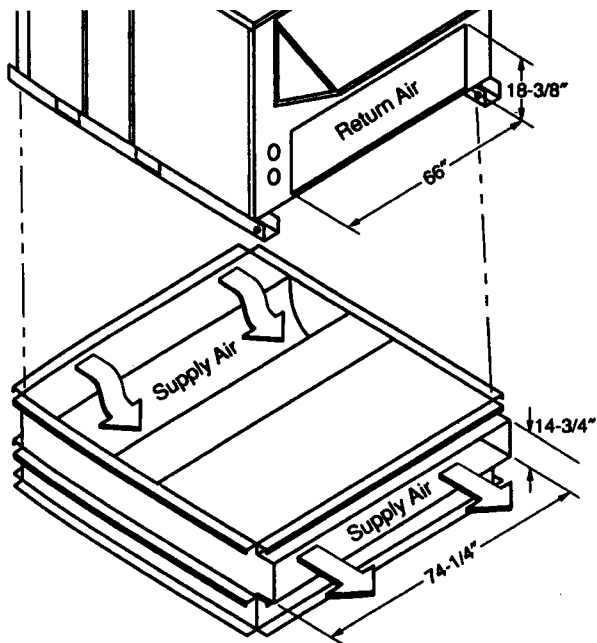

ECONOMIZER - HORIZONTAL / DOWNFLOW

Description	Model Number	Where Used
Fully Modulating	AXB060EMA	25 Ton
Three Position	AXB060EPA	25 Ton

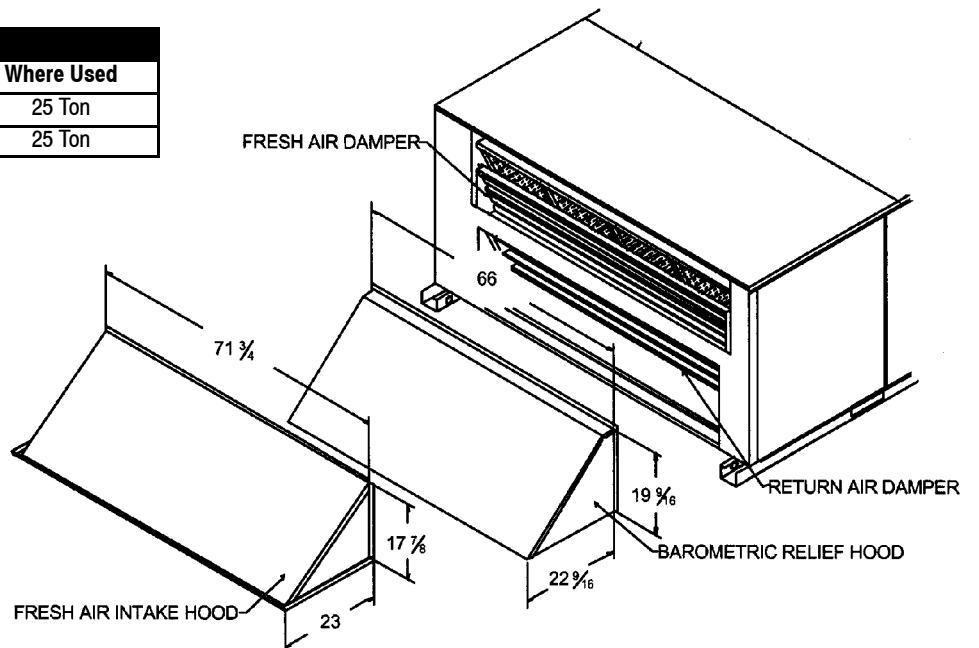

ACCESSORIES (CONT.)

COIL PROTECTION

Description	Model Number	Where Used
Coil Guard	AXB060CGA	25 Ton
Hail Guard	AXB060HGA	25 Ton

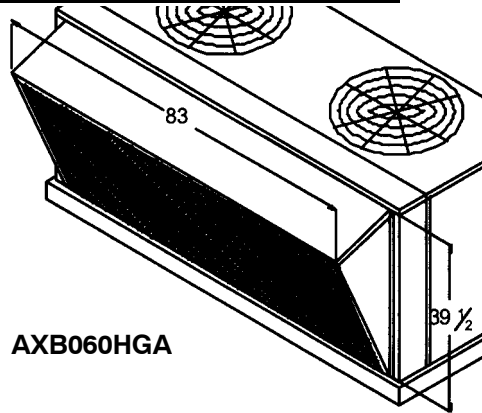

AXB060HGA

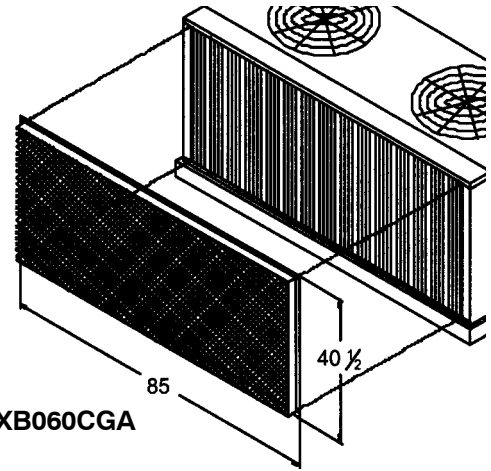

AXB060CGA

POWER EXHAUST

Description	Model Number	Where Used
208/230 Volt	AXB060PEH	PAS300H
460 Volt	AXB060PEL	PAS300L
575 Volt	AXB060PES	PAS300S

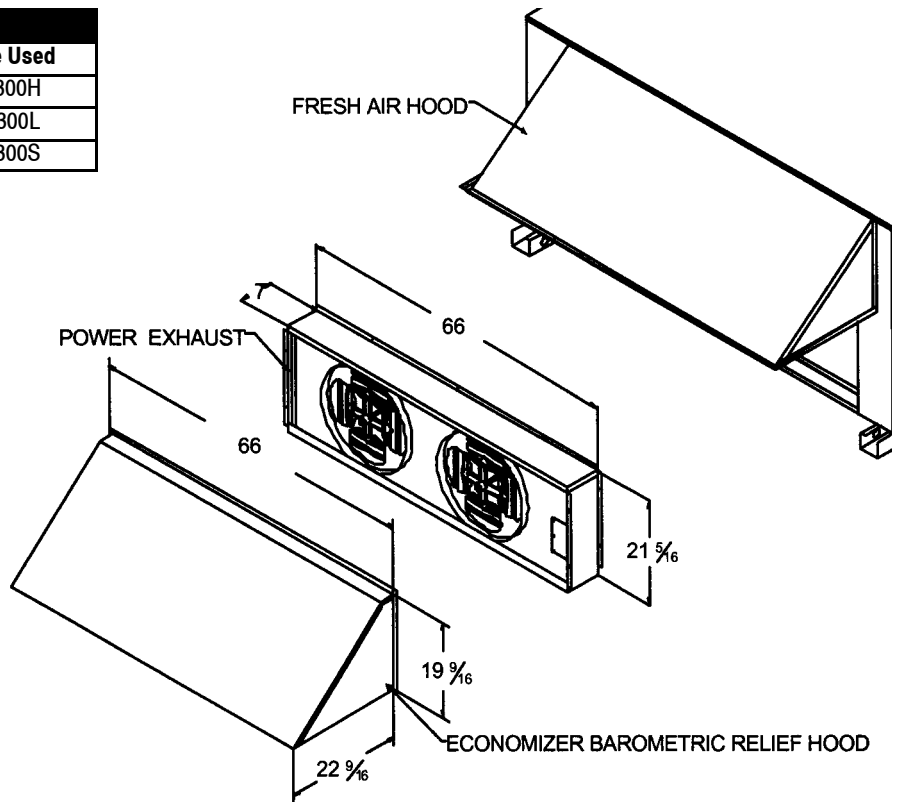

POWER EXHAUST PERFORMANCE DATA

Model	Volt/Phase/ Hertz	Motor			Unit					
		Qty	HP	RPM	Cir. Qty	LRA	FLA	MCA	Fuse Size	@0.1 CFM
AXB060PEH	208-230/3/60	2	3/4	1075	1	24.9	10.0	12.6	15	9,600
AXB060PEL	460/3/60	2	3/4	1075	1	N/A	4.4	5.6	8	9,600
AXB060PES	575	2	3/4	1050	1	N/A	3.0	3.8	5	9,600

ACCESSORIES (CONT.)

CONCENTRIC DUCT KIT

Description	Model Number	Where Used
24" x 48"	AXB260CTA	25 Ton

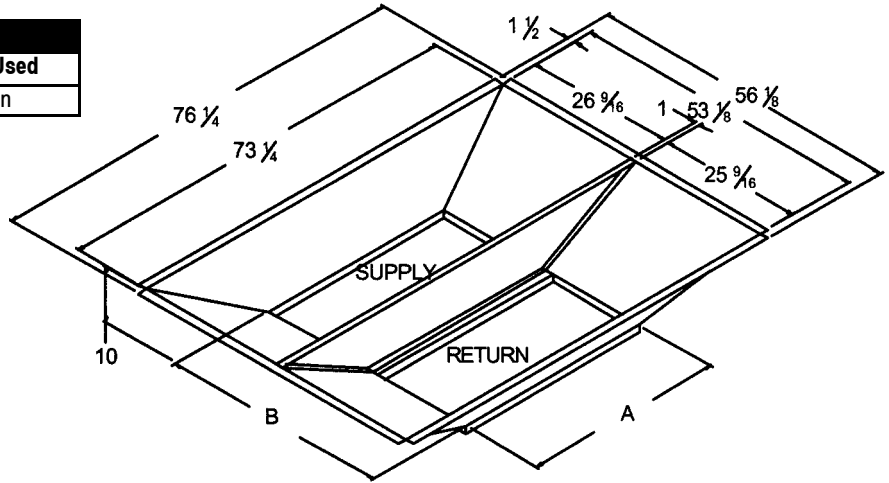

CONCENTRIC DIFFUSER

Description	Model Number	Used With
Flush Mount	AXB058CFA	25 Ton
Step Down	AXB058CSA	25 Ton

SEE PERFORMANCE DATA ON NEXT PAGE

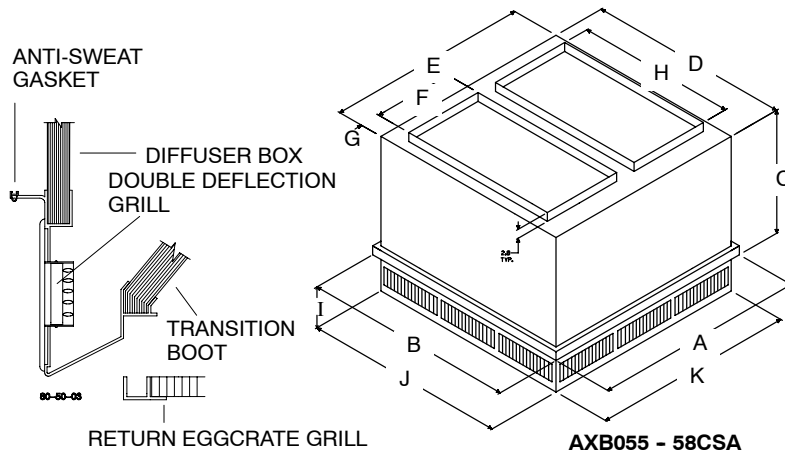
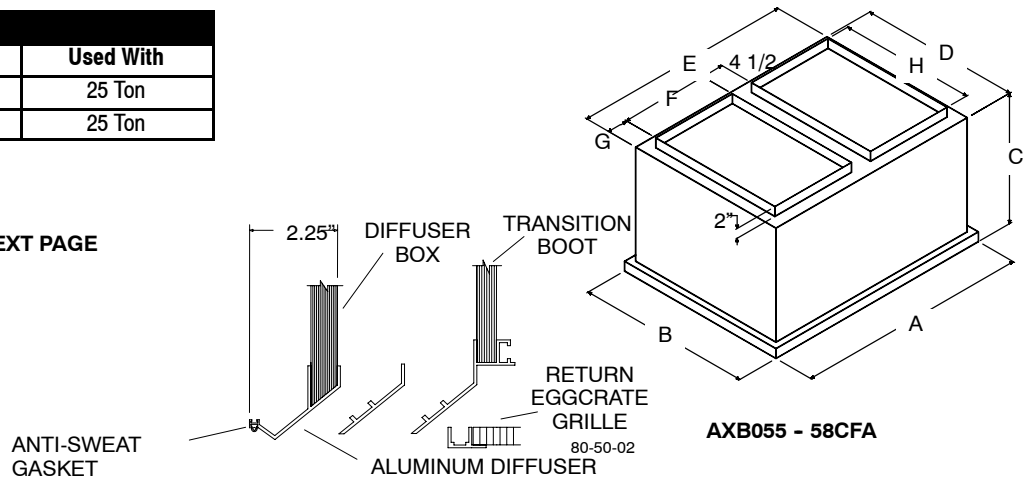

DIMENSIONS

Model Number	A	B	C	D	E	F	G	H	I	J	K	Duct Size
AXB058CFA	59-5/8	59-5/8	35-1/4	57	57	24	2-1/4	48	N/A	N/A	N/A	24 x 48
AXB058CSA	59-5/8	59-5/8	30-5/8	57-1/2	57-1/2	24	2-1/2	48	11-1/8	57-1/2	57-1/2	24 x 48

ACCESSORIES (CONT.)

CFA SERIES PERFORMANCE DATA

Part No. AXB	CFM	Static Pressure In. WC	Throw Feet	Neck Velocity FPM	Jet Velocity FPM	db Sound Level
058CFA	7200	.39	26-35	996	2093	45
	7400	.41	28-37	1024	2151	45
	7600	.43	29-38	1051	2209	45
	7800	.47	40-50	1079	2276	45
	8000	.50	42-51	1107	2326	50
	8200	.53	43-52	1134	2384	50

CSA SERIES PERFORMANCE DATA

Part No. AXB	CFM	Static Pressure In. WC	Throw Feet	Neck / Jet Velocity FPM	db Sound Levels
058CSA	7200	.39	33-38	827	25
	7400	.41	35-40	850	25
	7600	.43	36-41	873	25
	7800	.47	38-43	896	30
	8000	.50	39-44	918	30
	8200	.53	41-46	941	30

CSA/CFA NOTES:

1. All data is based on the Air Diffusion Council guidelines.
2. Throw data is based on Terminal Velocities of 75 FPM using isothermal air.
3. Throw is based on diffuser blades being directed in a straight pattern.
4. Actual sound levels are less than those shown.
5. Minimum height 9' above floor.

FRESH AIR DAMPERS

Description	Model Number	Used With
35% Motorized	AXB060FMA	25 Ton

LOW AMBIENT KIT

Model Number	Used With
AXB260LAA (25°)	25 Ton

ELECTRIC HEAT ACCESSORIES

MODEL	Nominal Voltage 3 Ph - 60 Hz	Heater Part No.	Electric Heat		Power Supply	
			FLA	KW	MCA	MOCP
PAS300H	208/240	AES034EHA	72 / 82	26 / 34	137 / 138	175 / 175
		AES056EHA	117 / 135	42 / 56	181 / 170	200 / 175
		AES075EHA	156 / 180	56 / 75	191 / 215	200 / 225
PAS300L	380	AES132ELA	32	21.6	80	100
		AES055ELA	54	36	93	100
	480	AES132ELA	39	32	70	90
		AES055ELA	66	55	84	90
		AES080ELA	96	80	114	125
PAS300S	575	AES030ESA	N/A	30	N/A	N/A
		AES050ESA	N/A	50	N/A	N/A
		AES060ESA	N/A	60	N/A	N/A
		AES070ESA	N/A	70	N/A	N/A

CONTROLS

OPERATING SEQUENCE

Cooling, Units Without Economizer – When thermostat calls for cooling, terminals G and Y1 are energized. The indoor (evaporator) fan contactor (IFC) and compressor contactor no. 1 (C1) are energized, and evaporator-fan motor (IFM), compressor no. 1, and condenser fan(s) start. The condenser-fan motor(s) runs continuously while unit is cooling. When the thermostat calls for a second stage of cooling by energizing Y2, compressor contactor no. 2 (C2) is energized and compressor no. 2 starts.

APPLICATION DATA

1. **DUCTWORK** – Ductwork should be attached to the curb on all units. Interior installation may proceed before unit is set in place on roof. If ductwork will be attached to the unit, do not drill in condensate drain pan area – leaks may result.
2. **THRU-THE-CURB SERVICE CONNECTIONS** – Roof curb connections allow field power wires, control wires, and gas supply to enter through the roof curb opening.
3. **THERMOSTAT** – Use of 2-stage cooling thermostat is recommended for all units. A 2-stage cooling thermostat is required on units with accessory economizer to provide integrated cooling.
4. **AIRFLOW** – Units are draw-thru on cooling and blow-thru on heating.
5. **MAXIMUM AIRFLOW** –To minimize the possibility of condensate blow-off from evaporator, airflow through units should not exceed 500 cfm/nominal ton.
6. **MINIMUM AIRFLOW** – The minimum airflow for cooling is 300 cfm/nominal ton.
7. **MINIMUM AMBIENT COOLING OPERATION TEMPERATURE** Units are designed to operate at outdoor temperatures down to 40 F.
8. **MAXIMUM OPERATING OUTDOOR-AIR TEMPERATURE** – For cooling, this temperature is 125 F. Refer to Cooling Capacities tables.
9. **INTERNAL UNIT DESIGN** – Due to the internal unit design (draw-thru over the motor), air path, and specially designed motors, the full horsepower (maximum continuous bhp) listed in the Physical Data table and the notes following each Fan Performance table can be utilized with extreme confidence. Using motors with the values listed in the Physical and Fan Performance Data tables will not result in nuisance tripping or premature motor failure. The unit warranty will not be affected.

GUIDE SPECIFICATIONS

CONDENSER FAN:

The unit shall have a single direct drive propeller fan/motor assembly mounted directly to a vertical-discharge grille panel that is easily removable. Motors shall have permanently lubricated sleeve bearings and inherent overload protection.

EVAPORATOR BLOWER:

The units shall have a single belt driven evaporator blower. The motor shall have permanently lubricated ball bearings and internal overload protection. An adjustable motor drive sheave for matching air flow requirements shall be standard. Additionally high static accessory kits shall be available for air flows above the standard requirement.

COILS:

The evaporator and condenser coils shall be fabricated with aluminum fins mechanically bonded to copper tubing. Both coils shall be pressure tested prior to assembly into the unit and electronically leak tested after assembly onto the unit.

The evaporator coil shall be protected from dust and debris on the return air side by factory installed 2" filters.