



14 SEER, 12 EER, PACKAGE GAS / ELECTRIC UNIT, 2 to 5 TONS

Single Phase, 208/230 V, 60 Hz

REFRIGERATION CIRCUIT

- Environmentally sound R-410A refrigerant
- Copper tube/aluminum fin condenser and evaporator coils
- Scroll compressors standard on all models

EASY TO INSTALL AND SERVICE

- Installs easily on a rooftop or at ground level
- Easy single-panel accessibility for maintenance and installation
- Easily converts to down discharge applications
- Combination gas heating and electric cooling

BUILT TO LAST

- Wire grille
- NOx-approved units available
- Induced-draft combustion and venting
- Pre-painted steel cabinet
- Direct spark ignition
- High efficiency X-13 indoor blower motor on all models
- Aluminized steel tubular heat exchanger
- Vertical condenser fan discharge
- Rust-proof base with integral sloping drain
- High and low pressure switches provide added reliability for the compressor

WARRANTY*

- 15 year heat exchanger limited warranty
- 5 year parts limited warranty (including compressor and coils)
 - With timely registration, an additional 5 year parts limited warranty (including compressor and coils)

*Applies to original purchaser/homeowner, some limitations may apply. See warranty certificate for complete details.



As an Energy Star® Partner, International Comfort Products has determined that this product meets the ENERGY STAR® guidelines for energy efficiency.



UNIT PERFORMANCE DATA

Model Number	COOLING				HEATING		Unit Dimensions Height x Width x Depth Inches (mm)	Operating Weight lbs / kg
	Nominal Capacity BTU/h	S.E.E.R	E.E.R.	S/T Ratio	Input BTU/h	Efficiency AFUE %		
PGN424040K0*A	24,000	14.3	12.0	.73	40,000	80.0	37x48x33 (940x1226x831)	307 (139)
PGN424060K0*A	24,000	14.3	12.0	.73	60,000	80.0	37x48x33 (940x1226x831)	307 (139)
PGN430040K0*A	28,400	14.3	12.0	.75	40,000	80.0	37x48x33 (940x1226x831)	319 (145)
PGN430060K0*A	28,400	14.3	12.0	.75	60,000	80.0	37x48x33 (940x1226x831)	319 (145)
PGN436060K0*A	34,200	14.2	12.0	.76	60,000	80.0	43x48x33 (1093x1226x831)	353 (160)
PGN436090K0*A	34,200	14.2	12.0	.76	90,000	79.3	43x48x33 (1093x1226x831)	353 (160)
PGN442060K0*A	40,500	14.3	12.0	.75	60,000	78.5	47x48x44 (1193x1226x1123)	435 (197)
PGN442090K0*A	40,500	14.3	12.0	.75	90,000	80.4	47x48x44 (1193x1226x1123)	435 (197)
PGN448090K0*A	48,000	14.3	12.0	.75	90,000	80.4	47x48x44 (1193x1226x1123)	453 (206)
PGN448115K0*A	48,000	14.3	12.0	.75	115,000	80.3	47x48x44 (1193x1226x1123)	453 (206)
PGN448130K0*A	48,000	14.3	12.0	.75	130,000	78.9	47x48x44 (1193x1226x1123)	453 (206)
PGN460090K0*A	59,000	14.0	12.0	.72	90,000	80.4	51x48x44 (1295x1226x1123)	481 (218)
PGN460115K0*A	59,000	14.0	12.0	.72	115,000	80.3	51x48x44 (1295x1226x1123)	481 (218)
PGN460130K0*A	59,000	14.0	12.0	.72	130,000	78.9	51x48x44 (1295x1226x1123)	481 (218)

* 0 = Standard Model, 1 = Low NOx California Model

UNIT SPECIFICATIONS

MODEL NUMBER	Electrical Data 208/230 - 1 - 60		Condenser									Sound Ratings (dBA)
			Coil			Fan Motor			Fan			
	Maximum HACR Breaker or Fuse	Minimum Circuit Ampacity	Total Face Area (ft. ²)	Fins Per Inch / Rows	Tube Diameter (inch)	Horse Power	Full Load Amps	Locked Rotor Amps	Diameter (inches)	RPM (Max.)	CFM (Design)	
PGN424040K0*A	30 amps	21.0	10.2	21 / 2	3/8	1/8	0.9	1.6	22	825	2200	71
PGN424060K0*A	30 amps	21.0	10.2	21 / 2	3/8	1/8	0.9	1.6	22	825	2200	71
PGN430040K0*A	30 amps	21.0	10.2	21 / 2	3/8	1/8	0.9	1.6	22	825	2800	73
PGN430060K0*A	30 amps	21.0	10.2	21 / 2	3/8	1/8	0.9	1.6	22	825	2800	73
PGN436060K0*A	35 amps	24.5	15.25	21 / 2	3/8	1/8	0.9	1.7	22	825	3000	76
PGN436090K0*A	35 amps	24.5	15.25	21 / 2	3/8	1/8	0.9	1.7	22	825	3000	76
PGN442060K0*A	45 amps	29.3	19.4	21 / 2	3/8	1/8	0.9	1.7	22	825	3500	74
PGN442090K0*A	45 amps	29.3	19.4	21 / 2	3/8	1/8	0.9	1.7	22	825	3500	74
PGN448090K0*A	50 amps	36.4	19.4	21 / 2	3/8	1/4	1.5	3.2	22	1100	3500	79
PGN448115K0*A	50 amps	36.4	19.4	21 / 2	3/8	1/4	1.5	3.2	22	1100	3500	79
PGN448130K0*A	50 amps	36.4	19.4	21 / 2	3/8	1/4	1.5	3.2	22	1100	3500	79
PGN460090K0*A	60 amps	42.5	23.3	21 / 2	3/8	1/4	1.9	4.0	22	1100	4200	79
PGN460115K0*A	60 amps	42.5	23.3	21 / 2	3/8	1/4	1.9	4.0	22	1100	4200	79
PGN460130K0*A	60 amps	42.5	23.3	21 / 2	3/8	1/4	1.9	4.0	22	1100	4200	79

* 0 = Standard Model, 1 = Low NOx California Model

MODEL NUMBER	Evaporator								Scroll Compressor		Factory Refrigerant Charge R-410A (lbs)	Shipping Weight (lbs)
	Coil			Motor		Blower			Rated Load Amps	Locked Rotor Amps		
	Total Face Area (ft. ²)	Fins Per Inch / Rows	Tube Diam. (inch)	HP	Full Load Amps	Size (inches)	RPM (Max)	CFM (Rated)				
PGN424040K0*A	3.7	17 / 3	3/8	1/2	4.1	10 x 10	1050	800	12.8	58.3	7.5	361
PGN424060K0*A	3.7	17 / 3	3/8	1/2	4.1	10 x 10	1050	800	12.8	58.3	7.5	361
PGN430040K0*A	3.7	17 / 3	3/8	1/2	4.1	10 x 10	1050	1000	12.8	64.0	7.8	373
PGN430060K0*A	3.7	17 / 3	3/8	1/2	4.1	10 x 10	1050	1000	12.8	64.0	7.8	373
PGN436060K0*A	3.7	15 / 4	3/8	3/4	6.0	11 x 10	1000	1200	14.1	77.0	9.8	407
PGN436090K0*A	3.7	15 / 4	3/8	3/4	6.0	11 x 10	1000	1200	14.1	77.0	9.8	407
PGN442060K0*A	4.7	17 / 3	3/8	3/4	6.0	11 x 10	1075	1400	17.9	112.0	11.0	497
PGN442090K0*A	4.7	17 / 3	3/8	3/4	6.0	11 x 10	1075	1400	17.9	112.0	11.0	497
PGN448090K0*A	5.7	17 / 3	3/8	1.0	7.6	11 x 10	1075	1600	21.8	117.0	10.5	515
PGN448115K0*A	5.7	17 / 3	3/8	1.0	7.6	11 x 10	1075	1600	21.8	117.0	10.5	515
PGN448130K0*A	5.7	17 / 3	3/8	1.0	7.6	11 x 10	1075	1600	21.8	117.0	10.5	515
PGN460090K0*A	5.7	17 / 4	3/8	1.0	7.6	11 x 10	1040	1750	26.4	134.0	14.5	543
PGN460115K0*A	5.7	17 / 4	3/8	1.0	7.6	11 x 10	1040	1750	26.4	134.0	14.5	543
PGN460130K0*A	5.7	17 / 4	3/8	1.0	7.6	11 x 10	1040	1750	26.4	134.0	14.5	543

* 0 = Standard Model, 1 = Low NOx California Model

PRESSURE SWITCHES

Switch Type	Cut-out Pressure (PSIG)	Reset (automatic) Pressure (PSIG)
High	650 +/- 15	420 +/- 15
Loss of Charge (Low)	20 +/- 5	45 +/- 10

UNIT AIRFLOW, Horizontal and Downflow Discharge, 230 Volts, Dry Coil

Model	Heating Rise Range	Motor Speed	Wire Color	External Static Pressure (Inches Water Column)									
					0.1	0.2	0.3	0.4	0.5	0.6	0.7	0.8	0.9
PGN424040	30 - 60° F (17 - 33° C)	Low	Blue	CFM	741	638	547	415	--	--	--	--	--
				Heating Rise (°F)	41	47	55	NA	NA	NA	NA	NA	NA
				Heating Rise (°C)	23	26	31	NA	NA	NA	NA	NA	NA
		Med-Low ²	Pink	CFM	898	820	738	662	536	--	--	--	--
				Heating Rise (°F)	34	37	41	46	56	NA	NA	NA	NA
				Heating Rise (°C)	19	20	23	25	31	NA	NA	NA	NA
		Medium ¹	Red	CFM	973	887	823	733	665	538	451	--	--
				Heating Rise (°F)	31	34	37	41	45	56	NA	NA	NA
				Heating Rise (°C)	17	19	20	23	25	31	NA	NA	NA
		Med-High	Orange	CFM	1140	1064	996	915	840	758	687	564	480
				Heating Rise (°F)	NA	NA	30	33	36	40	44	54	NA
				Heating Rise (°C)	NA	NA	17	18	20	22	24	30	NA
		High	Black	CFM	1202	1140	1082	1015	961	881	810	732	631
				Heating Rise (°F)	NA	NA	NA	30	31	34	37	41	48
				Heating Rise (°C)	NA	NA	NA	17	17	19	21	23	27
PGN424060	25 - 55° F (14 - 31° C)	Low	Blue	CFM	741	638	547	415	--	--	--	--	--
				Heating Rise (°F)	NA	NA	NA	NA	NA	NA	NA	NA	NA
				Heating Rise (°C)	NA	NA	NA	NA	NA	NA	NA	NA	NA
		Med-Low ²	Pink	CFM	898	820	738	662	536	--	--	--	--
				Heating Rise (°F)	49	54	NA	NA	NA	NA	NA	NA	NA
				Heating Rise (°C)	27	30	NA	NA	NA	NA	NA	NA	NA
		Medium	Red	CFM	973	887	823	733	665	538	451	--	--
				Heating Rise (°F)	46	50	54	NA	NA	NA	NA	NA	NA
				Heating Rise (°C)	25	28	30	NA	NA	NA	NA	NA	NA
		Med-High	Orange	CFM	1140	1064	996	915	840	758	687	564	480
				Heating Rise (°F)	39	42	45	49	53	NA	NA	NA	NA
				Heating Rise (°C)	22	23	25	27	29	NA	NA	NA	NA
		High ¹	Black	CFM	1202	1140	1082	1015	961	881	810	732	631
				Heating Rise (°F)	37	39	41	44	46	50	55	NA	NA
				Heating Rise (°C)	21	22	23	24	26	28	30	NA	NA
PGN430040	30 - 60° F (17 - 33° C)	Low	Blue	CFM	741	638	547	415	--	--	--	--	--
				Heating Rise (°F)	41	47	55	NA	NA	NA	NA	NA	NA
				Heating Rise (°C)	23	26	31	NA	NA	NA	NA	NA	NA
		Med-Low	Pink	CFM	898	820	738	662	536	--	--	--	--
				Heating Rise (°F)	34	37	41	46	56	NA	NA	NA	NA
				Heating Rise (°C)	19	20	23	25	31	NA	NA	NA	NA
		Medium ¹	Red	CFM	973	887	823	733	665	538	451	--	--
				Heating Rise (°F)	31	34	37	41	45	56	NA	NA	NA
				Heating Rise (°C)	17	19	20	23	25	31	NA	NA	NA
		Med-High ²	Orange	CFM	1140	1064	996	915	840	758	687	564	480
				Heating Rise (°F)	NA	NA	30	33	36	40	44	54	NA
				Heating Rise (°C)	NA	NA	17	18	20	22	24	30	NA
		High	Black	CFM	1202	1140	1082	1015	961	881	810	732	631
				Heating Rise (°F)	NA	NA	NA	30	31	34	37	41	48
				Heating Rise (°C)	NA	NA	NA	17	17	19	21	23	27
PGN430060	25 - 55° F (14 - 31° C)	Low	Blue	CFM	741	638	547	415	--	--	--	--	--
				Heating Rise (°F)	NA	NA	NA	NA	NA	NA	NA	NA	NA
				Heating Rise (°C)	NA	NA	NA	NA	NA	NA	NA	NA	NA
		Med-Low	Pink	CFM	898	820	738	662	536	--	--	--	--
				Heating Rise (°F)	49	54	NA	NA	NA	NA	NA	NA	NA
				Heating Rise (°C)	27	30	NA	NA	NA	NA	NA	NA	NA
		Medium	Red	CFM	973	887	823	733	665	538	451	--	--
				Heating Rise (°F)	46	50	54	NA	NA	NA	NA	NA	NA
				Heating Rise (°C)	25	28	30	NA	NA	NA	NA	NA	NA
		Med-High ²	Orange	CFM	1140	1064	996	915	840	758	687	564	480
				Heating Rise (°F)	39	42	45	49	53	NA	NA	NA	NA
				Heating Rise (°C)	22	23	25	27	29	NA	NA	NA	NA
		High ¹	Black	CFM	1202	1140	1082	1015	961	881	810	732	631
				Heating Rise (°F)	37	39	41	44	46	50	55	NA	NA
				Heating Rise (°C)	21	22	23	24	26	28	30	NA	NA

- refer to Notes at the end of the chart -

Model	Heating Rise Range	Motor Speed	Wire Color	External Static Pressure (Inches Water Column)											
				0.1	0.2	0.3	0.4	0.5	0.6	0.7	0.8	0.9			
PGN436060	25 – 55° F (14 – 31° C)	Low ¹	Blue	CFM	1206	1151	1085	1033	961	901	839	769	694		
				Heating Rise (°F)	37	39	41	43	46	49	53	NA	NA		
				Heating Rise (°C)	20	21	23	24	26	27	29	NA	NA		
		Med-Low ²	Pink	CFM	1369	1317	1262	1208	1152	1095	1037	979	919		
				Heating Rise (°F)	32	34	35	37	39	41	43	45	48		
				Heating Rise (°C)	18	19	20	20	21	23	24	25	27		
		Medium	Red	CFM	1419	1370	1315	1269	1209	1161	1101	1043	984		
				Heating Rise (°F)	31	32	34	35	37	38	40	43	45		
				Heating Rise (°C)	17	18	19	19	20	21	22	24	25		
		Med-High	Orange	CFM	1557	1507	1464	1412	1365	1310	1265	1212	1154		
				Heating Rise (°F)	29	29	30	31	33	34	35	37	39		
				Heating Rise (°C)	16	16	17	17	18	19	20	20	21		
		High	Black	CFM	1599	1553	1505	1460	1410	1361	1310	1262	1203		
				Heating Rise (°F)	28	29	30	30	32	33	34	35	37		
				Heating Rise (°C)	15	16	16	17	18	18	19	20	21		
		PGN436090	35 – 65° F (19 – 36° C)	Low	Blue	CFM	1206	1151	1085	1033	961	901	839	769	694
						Heating Rise (°F)	56	59	63	NA	NA	NA	NA	NA	NA
						Heating Rise (°C)	31	33	35	NA	NA	NA	NA	NA	NA
Med-Low ²	Pink			CFM	1369	1317	1262	1208	1152	1095	1037	979	919		
				Heating Rise (°F)	50	52	54	56	59	62	NA	NA	NA		
				Heating Rise (°C)	28	29	30	31	33	35	NA	NA	NA		
Medium	Red			CFM	1419	1370	1315	1269	1209	1161	1101	1043	984		
				Heating Rise (°F)	48	50	52	54	56	59	62	65	NA		
				Heating Rise (°C)	27	28	29	30	31	33	34	36	NA		
Med-High	Orange			CFM	1557	1507	1464	1412	1365	1310	1265	1212	1154		
				Heating Rise (°F)	44	45	46	48	50	52	54	56	59		
				Heating Rise (°C)	24	25	26	27	28	29	30	31	33		
High ¹	Black			CFM	1599	1553	1505	1460	1410	1361	1310	1262	1203		
				Heating Rise (°F)	43	44	45	47	48	50	52	54	57		
				Heating Rise (°C)	24	24	25	26	27	28	29	30	31		
PGN442060	25 – 55° F (14 – 31° C)			Low ¹	Blue	CFM	1295	1234	1182	1126	1075	1016	955	898	857
						Heating Rise (°F)	34	36	38	39	41	44	47	49	52
						Heating Rise (°C)	19	20	21	22	23	24	26	27	29
		Med-Low	Pink	CFM	1345	1282	1235	1194	1140	1095	1027	974	921		
				Heating Rise (°F)	33	35	36	37	39	41	43	46	48		
				Heating Rise (°C)	18	19	20	21	22	23	24	25	27		
		Medium	Red	CFM	1505	1452	1413	1358	1323	1282	1234	1169	1130		
				Heating Rise (°F)	30	31	31	33	34	35	36	38	39		
				Heating Rise (°C)	16	17	17	18	19	19	20	21	22		
		Med-High ²	Orange	CFM	1545	1492	1449	1411	1362	1313	1278	1231	1188		
				Heating Rise (°F)	29	30	31	31	33	34	35	36	37		
				Heating Rise (°C)	16	17	17	17	18	19	19	20	21		
		High	Black	CFM	1705	1643	1607	1568	1518	1483	1448	1404	1360		
				Heating Rise (°F)	26	27	28	28	29	30	31	32	33		
				Heating Rise (°C)	14	15	15	16	16	17	17	18	18		
		PGN442090	35 – 65° F (19 – 36° C)	Low	Blue	CFM	1295	1234	1182	1126	1075	1016	955	898	857
						Heating Rise (°F)	53	55	58	60	63	NA	NA	NA	NA
						Heating Rise (°C)	29	31	32	34	35	NA	NA	NA	NA
Med-Low	Pink			CFM	1345	1282	1235	1194	1140	1095	1027	974	921		
				Heating Rise (°F)	51	53	55	57	60	62	NA	NA	NA		
				Heating Rise (°C)	28	29	31	32	33	35	NA	NA	NA		
Medium ¹	Red			CFM	1505	1452	1413	1358	1323	1282	1234	1169	1130		
				Heating Rise (°F)	45	47	48	50	51	53	55	58	60		
				Heating Rise (°C)	25	26	27	28	29	29	31	32	33		
Med-High ²	Orange			CFM	1545	1492	1449	1411	1362	1313	1278	1231	1188		
				Heating Rise (°F)	44	46	47	48	50	52	53	55	57		
				Heating Rise (°C)	24	25	26	27	28	29	30	31	32		
High	Black			CFM	1705	1643	1607	1568	1518	1483	1448	1404	1360		
				Heating Rise (°F)	40	41	42	43	45	46	47	48	50		
				Heating Rise (°C)	22	23	24	24	25	25	26	27	28		

- refer to Notes at the end of the chart -

Model	Heating Rise Range	Motor Speed	Wire Color	External Static Pressure (Inches Water Column)									
				0.1	0.2	0.3	0.4	0.5	0.6	0.7	0.8	0.9	
PGN448090	35 - 65° F (19 - 36° C)	Low ¹	Blue	CFM	1445	1389	1341	1281	1236	1189	1139	1072	1027
				Heating Rise (°F)	47	49	51	53	55	57	60	63	NA
				Heating Rise (°C)	26	27	28	29	31	32	33	35	NA
		Med-Low ²	Pink	CFM	1678	1635	1602	1558	1513	1474	1438	1404	1349
				Heating Rise (°F)	41	42	42	44	45	46	47	48	50
				Heating Rise (°C)	23	23	24	24	25	26	26	27	28
		Medium	Red	CFM	1962	1915	1880	1843	1794	1753	1711	1675	1628
				Heating Rise (°F)	35	36	36	37	38	39	40	41	42
				Heating Rise (°C)	19	20	20	20	21	22	22	23	23
		Med-High	Orange	CFM	2131	2088	2065	2013	1982	1941	1888	1860	1785
				Heating Rise (°F)	NA	NA	NA	NA	NA	35	36	37	38
				Heating Rise (°C)	NA	NA	NA	NA	NA	19	20	20	21
		High	Black	CFM	2461	2409	2339	2286	2192	2140	2062	1968	1874
				Heating Rise (°F)	NA	NA	NA	NA	NA	NA	NA	35	36
				Heating Rise (°C)	NA	NA	NA	NA	NA	NA	NA	19	20
PGN448115	30 - 60° F (17 - 33° C)	Low	Blue	CFM	1445	1389	1341	1281	1236	1189	1139	1072	1027
				Heating Rise (°F)	60	NA	NA	NA	NA	NA	NA	NA	NA
				Heating Rise (°C)	33	NA	NA	NA	NA	NA	NA	NA	NA
		Med-Low ²	Pink	CFM	1678	1635	1602	1558	1513	1474	1438	1404	1349
				Heating Rise (°F)	52	53	54	56	57	59	60	NA	NA
				Heating Rise (°C)	29	30	30	31	32	33	34	NA	NA
		Medium	Red	CFM	1962	1915	1880	1843	1794	1753	1711	1675	1628
				Heating Rise (°F)	44	45	46	47	48	50	51	52	53
				Heating Rise (°C)	25	25	26	26	27	28	28	29	30
		Med-High ¹	Orange	CFM	2131	2088	2065	2013	1982	1941	1888	1860	1785
				Heating Rise (°F)	41	42	42	43	44	45	46	47	49
				Heating Rise (°C)	23	23	23	24	24	25	26	26	27
		High	Black	CFM	2461	2409	2339	2286	2192	2140	2062	1968	1874
				Heating Rise (°F)	35	36	37	38	40	41	42	44	46
				Heating Rise (°C)	20	20	21	21	22	23	23	25	26
PGN448130	35 - 65° F (19 - 36° C)	Low	Blue	CFM	1445	1389	1341	1281	1236	1189	1139	1072	1027
				Heating Rise (°F)	NA	NA	NA	NA	NA	NA	NA	NA	NA
				Heating Rise (°C)	NA	NA	NA	NA	NA	NA	NA	NA	NA
		Med-Low ²	Pink	CFM	1678	1635	1602	1558	1513	1474	1438	1404	1349
				Heating Rise (°F)	57	59	60	62	64	65	NA	NA	NA
				Heating Rise (°C)	32	33	33	34	35	36	NA	NA	NA
		Medium	Red	CFM	1962	1915	1880	1843	1794	1753	1711	1675	1628
				Heating Rise (°F)	49	50	51	52	54	55	56	57	59
				Heating Rise (°C)	27	28	28	29	30	31	31	32	33
		Med-High ¹	Orange	CFM	2131	2088	2065	2013	1982	1941	1888	1860	1785
				Heating Rise (°F)	45	46	47	48	49	50	51	52	54
				Heating Rise (°C)	25	26	26	27	27	28	28	29	30
		High	Black	CFM	2461	2409	2339	2286	2192	2140	2062	1968	1874
				Heating Rise (°F)	39	40	41	42	44	45	47	49	51
				Heating Rise (°C)	22	22	23	23	24	25	26	27	29
PGN460090	35 - 65° F (19 - 36° C)	Low ¹	Blue	CFM	1448	1362	1296	1226	1168	1108	1071	998	905
				Heating Rise (°F)	47	50	52	55	58	61	63	NA	NA
				Heating Rise (°C)	26	28	29	31	32	34	35	NA	NA
		Med-Low	Pink	CFM	1722	1675	1614	1543	1499	1442	1408	1356	1308
				Heating Rise (°F)	39	41	42	44	45	47	48	50	52
				Heating Rise (°C)	22	23	23	24	25	26	27	28	29
		Medium ²	Red	CFM	1887	1847	1783	1726	1677	1625	1578	1527	1432
				Heating Rise (°F)	36	37	38	39	41	42	43	45	47
				Heating Rise (°C)	20	20	21	22	23	23	24	25	26
		Med-High	Orange	CFM	2055	2008	1958	1927	1900	1768	1685	1581	1458
				Heating Rise (°F)	NA	NA	35	35	36	38	40	43	47
				Heating Rise (°C)	NA	NA	19	20	20	21	22	24	26
		High	Black	CFM	2292	2238	2158	2049	1935	1840	1732	1635	1513
				Heating Rise (°F)	NA	NA	NA	NA	35	37	39	42	45
				Heating Rise (°C)	NA	NA	NA	NA	20	21	22	23	25

- refer to Notes at the end of the chart -

Model	Heating Rise Range	Motor Speed	Wire Color		External Static Pressure (Inches Water Column)								
					0.1	0.2	0.3	0.4	0.5	0.6	0.7	0.8	0.9
PGN460115	30 - 60° F (17 - 33° C)	Low	Blue	CFM	1448	1362	1296	1226	1168	1108	1071	998	905
				Heating Rise (°F)	60	NA	NA	NA	NA	NA	NA	NA	NA
				Heating Rise (°C)	33	NA	NA	NA	NA	NA	NA	NA	NA
		Med-Low	Pink	CFM	1722	1675	1614	1543	1499	1442	1408	1356	1308
				Heating Rise (°F)	50	52	54	56	58	60	NA	NA	NA
				Heating Rise (°C)	28	29	30	31	32	33	NA	NA	NA
		Medium ²	Red	CFM	1887	1847	1783	1726	1677	1625	1578	1527	1432
				Heating Rise (°F)	46	47	49	50	52	53	55	57	NA
				Heating Rise (°C)	26	26	27	28	29	30	31	32	NA
		Med-High ¹	Orange	CFM	2055	2008	1958	1927	1900	1768	1685	1581	1458
				Heating Rise (°F)	42	43	44	45	46	49	52	55	60
				Heating Rise (°C)	23	24	25	25	25	27	29	31	33
		High	Black	CFM	2292	2238	2158	2049	1935	1840	1732	1635	1513
				Heating Rise (°F)	38	39	40	42	45	47	50	53	57
				Heating Rise (°C)	21	22	22	24	25	26	28	30	32
PGN460130	35 - 65° F (19 - 36° C)	Low	Blue	CFM	1448	1321	1282	1235	1192	1145	1101	1057	1011
				Heating Rise (°F)	NA	NA	NA	NA	NA	NA	NA	NA	NA
				Heating Rise (°C)	NA	NA	NA	NA	NA	NA	NA	NA	NA
		Med-Low	Pink	CFM	1722	1675	1614	1543	1499	1442	1408	1356	1308
				Heating Rise (°F)	56	57	60	62	64	NA	NA	NA	NA
				Heating Rise (°C)	31	32	33	35	36	NA	NA	NA	NA
		Medium ²	Red	CFM	1887	1847	1783	1726	1677	1625	1578	1527	1432
				Heating Rise (°F)	51	52	54	56	57	59	61	63	NA
				Heating Rise (°C)	28	29	30	31	32	33	34	35	NA
		Med-High ¹	Orange	CFM	2055	2008	1958	1927	1900	1768	1685	1581	1458
				Heating Rise (°F)	47	48	49	50	51	54	57	61	NA
				Heating Rise (°C)	26	27	27	28	28	30	32	34	NA
		High	Black	CFM	2292	2238	2158	2049	1935	1840	1732	1635	1513
				Heating Rise (°F)	42	43	45	47	50	52	56	59	64
				Heating Rise (°C)	23	24	25	26	28	29	31	33	35

* Air delivery values are without air filter and are for dry coil (See Pressure Drop tables). Deduct field-supplied air filter pressure drop and wet coil pressure drop to obtain external static pressure available for ducting.

1. Factory-shipped heating speed
 2. Factory-shipped cooling speed
- NA - Not allowed for heating speed

FILTER PRESSURE DROP																			
FILTER SIZE	CFM																		
	500	600	700	800	900	1000	1100	1200	1300	1400	1500	1600	1700	1800	1900	2000	2100	2200	2300
	Pressure Drop (inches water column)																		
20 x 20 x 1	0.05	0.07	0.08	0.10	0.12	0.13	0.14	0.15	—	—	—	—	—	—	—	—	—	—	—
20 x 24 x 1	—	—	—	—	0.09	0.10	0.11	0.13	0.14	0.15	0.16	—	—	—	—	—	—	—	—
24 x 30 x 1	—	—	—	—	—	—	—	0.07	0.08	0.09	0.10	0.11	0.12	0.13	0.14	0.15	0.16	0.17	0.18
24 x 36 x 1	—	—	—	—	—	—	—	0.06	0.07	0.07	0.08	0.09	0.09	0.10	0.11	0.12	0.13	0.14	0.14

Minimum Filter Requirements:
20 x 20 x 1 = PGN424040
20 x 24 x 1 = PGN424060, PGN430 (all)
24 x 30 x 1 = PGN436 (all), PGN442 (all)
24 x 36 x 1 = PGN448 (all), PGN460 (all)

PGN424 COOLING PERFORMANCE																			
EVAPORATOR AIR		CONDENSER ENTERING AIR TEMPERATURES °F (°C)																	
CFM / BF	Ewb	75 (23.9)			85 (29.4)			95 (35)			105 (40.6)			115 (46.1)			125 (51.7)		
		Capacity BTU/h x 1000		Total System kW	Capacity BTU/h x 1000		Total System kW	Capacity BTU/h x 1000		Total System kW	Capacity BTU/h x 1000		Total System kW	Capacity BTU/h x 1000		Total System kW	Capacity BTU/h x 1000		Total System kW
		Total	Sens		Total	Sens		Total	Sens		Total	Sens		Total	Sens		Total	Sens	
700 / 0.02	57	23.13	23.13	1.51	21.91	21.91	1.72	20.50	20.50	1.96	18.92	18.92	2.21	17.16	17.16	2.50	15.20	15.20	2.81
	62	24.10	21.63	1.51	22.43	20.43	1.73	20.57	20.42	1.96	18.92	18.92	2.21	17.15	17.15	2.50	15.20	15.20	2.81
	63*	24.71	17.79	1.51	23.02	16.68	1.73	21.08	15.52	1.96	18.86	14.31	2.21	16.35	13.06	2.49	13.60	13.49	2.78
	67	26.79	18.40	1.51	25.29	17.46	1.73	23.34	16.34	1.98	21.10	15.15	2.24	18.59	13.94	2.52	15.78	12.69	2.82
	72	28.73	14.69	1.52	27.87	14.14	1.74	26.34	13.34	1.98	24.27	12.35	2.26	21.74	11.26	2.56	18.87	10.11	2.88
800 / 0.03	57	24.40	24.40	1.53	23.11	23.11	1.75	21.64	21.64	1.99	19.98	19.98	2.25	18.13	18.13	2.54	16.08	16.08	2.85
	62	24.87	23.37	1.53	23.20	23.00	1.75	21.64	21.64	1.99	19.98	19.98	2.25	18.13	18.13	2.54	16.08	16.08	2.85
	63*	25.40	19.01	1.53	23.70	17.92	1.75	21.68	16.72	1.99	19.39	15.47	2.24	16.83	14.16	2.52	14.31	14.31	2.82
	67	27.34	19.51	1.53	25.95	18.71	1.75	24.00	17.61	2.00	21.67	16.38	2.27	19.09	15.13	2.55	16.24	13.80	2.85
	72	29.18	15.26	1.54	28.30	14.76	1.76	26.88	14.05	2.01	24.85	13.13	2.28	22.30	12.04	2.58	19.34	10.88	2.91
900 / 0.03	57	25.44	25.44	1.55	24.15	24.15	1.77	22.62	22.62	2.02	20.89	20.89	2.29	18.97	18.97	2.57	16.83	16.83	2.89
	62	25.53	25.30	1.55	24.15	24.15	1.77	22.62	22.62	2.02	20.89	20.89	2.29	18.96	18.96	2.57	16.83	16.83	2.89
	63*	25.90	20.12	1.55	24.23	19.09	1.77	22.15	17.86	2.02	19.82	16.57	2.27	17.24	15.18	2.54	14.96	14.96	2.85
	67	27.68	20.49	1.55	26.43	19.86	1.77	24.51	18.81	2.02	22.14	17.58	2.30	19.50	16.26	2.58	16.82	16.82	2.89
	72	29.46	15.74	1.56	28.58	15.29	1.78	27.24	14.69	2.03	25.27	13.83	2.30	22.72	12.78	2.60	19.71	11.61	2.93

PGN430 COOLING PERFORMANCE																			
EVAPORATOR AIR		CONDENSER ENTERING AIR TEMPERATURES °F (°C)																	
CFM / BF	Ewb	75 (23.9)			85 (29.4)			95 (35)			105 (40.6)			115 (46.1)			125 (51.7)		
		Capacity BTU/h x 1000		Total System kW	Capacity BTU/h x 1000		Total System kW	Capacity BTU/h x 1000		Total System kW	Capacity BTU/h x 1000		Total System kW	Capacity BTU/h x 1000		Total System kW	Capacity BTU/h x 1000		Total System kW
		Total	Sens		Total	Sens		Total	Sens		Total	Sens		Total	Sens		Total	Sens	
875 / 0.03	57	28.46	28.46	1.82	26.75	26.75	2.05	24.89	24.89	2.31	22.87	22.87	2.60	20.70	20.70	2.91	18.40	18.40	3.25
	62	29.16	24.94	1.82	27.05	24.24	2.05	24.89	24.89	2.31	22.86	22.86	2.60	20.70	20.70	2.91	18.39	18.39	3.25
	63*	29.82	20.37	1.82	27.65	19.70	2.06	25.25	18.93	2.31	22.60	18.05	2.59	19.73	17.05	2.89	16.70	15.92	3.21
	67	32.32	21.11	1.81	30.19	20.56	2.06	27.78	19.87	2.33	25.09	19.05	2.63	22.19	18.13	2.93	19.08	17.11	3.26
	72	35.18	16.93	1.82	33.30	16.52	2.06	31.09	15.99	2.33	28.50	15.30	2.63	25.62	14.49	2.97	22.41	13.55	3.33
1000 / 0.04	57	29.83	29.83	1.85	28.06	28.06	2.10	26.12	26.12	2.37	24.01	24.01	2.65	21.74	21.74	2.97	19.33	19.33	3.31
	62	30.00	26.83	1.85	28.06	28.06	2.10	26.11	26.11	2.37	24.00	24.00	2.65	21.74	21.74	2.97	19.33	19.33	3.31
	63*	30.52	21.77	1.85	28.31	21.13	2.10	25.84	20.35	2.36	23.13	19.46	2.64	20.21	18.43	2.94	17.36	17.36	3.26
	67	32.96	22.50	1.85	30.84	22.03	2.09	28.40	21.37	2.37	25.67	20.57	2.67	22.69	19.62	2.99	19.55	18.54	3.31
	72	35.69	17.67	1.85	33.82	17.32	2.10	31.62	16.85	2.37	29.05	16.22	2.67	26.12	15.44	3.01	22.85	14.52	3.37
1125 / 0.05	57	30.95	30.95	1.88	29.15	29.15	2.13	27.15	27.15	2.41	24.97	24.97	2.71	22.62	22.62	3.03	20.12	20.12	3.37
	62	30.94	30.94	1.88	29.15	29.15	2.13	27.15	27.15	2.41	24.96	24.96	2.71	22.62	22.62	3.03	20.12	20.12	3.37
	63*	31.04	23.08	1.88	28.81	22.48	2.13	26.30	21.70	2.40	23.56	20.78	2.68	20.65	20.48	2.99	18.05	18.05	3.32
	67	33.41	23.79	1.88	31.32	23.40	2.13	28.87	22.80	2.40	26.11	22.00	2.71	23.10	21.02	3.04	20.11	20.11	3.37
	72	36.05	18.34	1.89	34.17	18.04	2.13	31.98	17.63	2.41	29.41	17.06	2.71	26.48	16.33	3.05	23.17	15.44	3.41

– refer to Legend, Notes, and Formulas at the end of the chart –

PGN436 COOLING PERFORMANCE																			
EVAPORATOR AIR		CONDENSER ENTERING AIR TEMPERATURES °F (°C)																	
CFM / BF	Ewb	75 (23.9)			85 (29.4)			95 (35)			105 (40.6)			115 (46.1)			125 (51.7)		
		Capacity BTU/h x 1000		Total System kW	Capacity BTU/h x 1000		Total System kW	Capacity BTU/h x 1000		Total System kW	Capacity BTU/h x 1000		Total System kW	Capacity BTU/h x 1000		Total System kW	Capacity BTU/h x 1000		Total System kW
		Total	Sens		Total	Sens		Total	Sens		Total	Sens		Total	Sens		Total	Sens	
1050 / 0.02	57	33.74	33.74	2.21	31.86	31.86	2.47	29.86	29.86	2.76	27.71	27.71	3.08	25.42	25.42	3.42	23.00	23.00	3.79
	62	34.63	29.69	2.22	32.34	29.18	2.48	29.93	29.78	2.76	27.71	27.71	3.08	25.42	25.42	3.42	23.00	23.00	3.79
	63*	35.42	24.26	2.23	33.09	23.73	2.49	30.56	23.09	2.77	27.82	22.33	3.08	24.86	21.44	3.40	21.70	20.43	3.75
	67	38.42	25.21	2.23	36.04	24.74	2.50	33.47	24.17	2.80	30.67	23.47	3.13	27.66	22.66	3.47	24.44	21.74	3.83
	72	42.11	20.41	2.24	39.77	19.99	2.51	37.26	19.49	2.81	34.52	18.88	3.14	31.52	18.16	3.50	28.25	17.30	3.89
1200 / 0.03	57	35.34	35.34	2.28	33.39	33.39	2.55	31.30	31.30	2.84	29.06	29.06	3.16	26.68	26.68	3.50	24.14	24.14	3.88
	62	35.58	32.00	2.28	33.39	33.39	2.55	31.30	31.30	2.84	29.06	29.06	3.16	26.67	26.67	3.50	24.14	24.14	3.88
	63*	36.26	25.97	2.28	33.86	25.44	2.55	31.25	24.80	2.83	28.44	24.04	3.14	25.41	23.15	3.47	22.21	22.09	3.82
	67	39.24	26.97	2.28	36.82	26.54	2.55	34.20	26.00	2.85	31.34	25.31	3.18	28.25	24.49	3.54	24.96	23.55	3.90
1350 / 0.03	72	42.80	21.39	2.29	40.39	20.99	2.56	37.86	20.53	2.86	35.10	19.97	3.19	32.08	19.29	3.55	28.76	18.46	3.95
	57	36.70	36.70	2.33	34.69	34.69	2.60	32.53	32.53	2.90	30.20	30.20	3.23	27.73	27.73	3.59	25.09	25.09	3.96
	62	36.70	36.70	2.33	34.69	34.69	2.60	32.52	32.52	2.90	30.20	30.20	3.23	27.72	27.72	3.59	25.09	25.09	3.96
	63*	36.89	27.59	2.33	34.44	27.08	2.60	31.78	26.44	2.90	28.92	25.68	3.21	25.86	24.75	3.54	22.78	22.78	3.90
	67	39.83	28.62	2.33	37.38	28.23	2.60	34.73	27.73	2.90	31.84	27.07	3.23	28.71	26.25	3.60	25.40	25.24	3.97
72	43.27	22.31	2.35	40.81	21.92	2.62	38.24	21.49	2.92	35.47	20.97	3.25	32.45	20.35	3.61	29.11	19.57	4.00	

PGN442 COOLING PERFORMANCE																			
EVAPORATOR AIR		CONDENSER ENTERING AIR TEMPERATURES °F (°C)																	
CFM / BF	Ewb	75 (23.9)			85 (29.4)			95 (35)			105 (40.6)			115 (46.1)			125 (51.7)		
		Capacity BTU/h x 1000		Total System kW	Capacity BTU/h x 1000		Total System kW	Capacity BTU/h x 1000		Total System kW	Capacity BTU/h x 1000		Total System kW	Capacity BTU/h x 1000		Total System kW	Capacity BTU/h x 1000		Total System kW
		Total	Sens		Total	Sens		Total	Sens		Total	Sens		Total	Sens		Total	Sens	
1225 / 0.03	57	39.18	39.18	2.56	36.42	36.42	2.90	33.76	33.76	3.28	31.03	31.03	3.70	28.30	28.30	4.17	25.52	25.52	4.68
	62	40.87	35.89	2.57	37.42	34.32	2.91	34.11	32.73	3.28	31.02	31.02	3.70	28.29	28.29	4.17	25.52	25.52	4.68
	63*	42.42	29.68	2.58	38.64	28.15	2.92	35.18	26.75	3.29	31.48	25.22	3.70	27.69	23.63	4.16	23.81	21.97	4.65
	67	46.44	30.98	2.60	42.97	29.69	2.95	39.60	28.41	3.33	36.16	27.09	3.75	32.63	25.72	4.22	28.89	24.22	4.72
	72	50.49	25.03	2.63	47.40	24.14	2.98	43.83	22.99	3.36	40.24	21.81	3.79	36.59	20.60	4.26	32.85	19.35	4.77
1400 / 0.04	57	41.90	41.90	2.62	38.93	38.93	2.96	36.19	36.19	3.34	33.33	33.33	3.77	30.43	30.43	4.24	27.48	27.48	4.75
	62	42.97	39.09	2.63	39.22	37.25	2.96	36.18	36.18	3.34	33.33	33.33	3.77	30.42	30.42	4.24	27.48	27.48	4.75
	63*	43.96	31.91	2.63	40.21	30.40	2.97	36.67	28.96	3.35	32.87	27.39	3.76	28.97	25.74	4.22	24.93	23.97	4.71
	67	47.54	33.05	2.65	43.97	31.76	2.99	40.50	30.45	3.38	36.96	29.10	3.80	33.35	27.69	4.27	29.66	26.21	4.78
1575 / 0.05	72	51.19	26.03	2.68	48.08	25.20	3.03	44.60	24.15	3.41	40.91	22.95	3.84	37.20	21.73	4.31	33.39	20.47	4.83
	57	44.01	44.01	2.67	41.03	41.03	3.02	38.13	38.13	3.40	35.17	35.17	3.83	32.15	32.15	4.30	29.08	29.08	4.82
	62	44.16	43.83	2.67	41.03	41.03	3.02	38.12	38.12	3.40	35.17	35.17	3.83	32.15	32.15	4.30	29.08	29.08	4.82
	63*	44.80	33.83	2.68	41.29	32.44	3.02	37.88	31.05	3.40	34.03	29.43	3.82	30.01	27.70	4.27	25.94	25.82	4.77
	67	48.33	34.96	2.69	44.73	33.72	3.04	41.17	32.38	3.42	37.57	30.99	3.85	33.89	29.55	4.31	30.16	28.02	4.83
72	51.62	26.90	2.73	48.32	25.98	3.08	45.11	25.19	3.46	41.35	23.97	3.89	37.59	22.76	4.36	33.74	21.50	4.88	

– refer to Legend, Notes, and Formulas at the end of the chart –

PGN448 COOLING PERFORMANCE																			
EVAPORATOR AIR		CONDENSER ENTERING AIR TEMPERATURES °F (°C)																	
CFM / BF	Ewb	75 (23.9)			85 (29.4)			95 (35)			105 (40.6)			115 (46.1)			125 (51.7)		
		Capacity BTU/h x 1000		Total System kW	Capacity BTU/h x 1000		Total System kW	Capacity BTU/h x 1000		Total System kW	Capacity BTU/h x 1000		Total System kW	Capacity BTU/h x 1000		Total System kW	Capacity BTU/h x 1000		Total System kW
		Total	Sens		Total	Sens		Total	Sens		Total	Sens		Total	Sens		Total	Sens	
1400 / 0.03	57	48.44	48.44	3.27	45.41	45.41	3.60	42.35	42.35	3.93	39.25	39.25	4.28	36.07	36.07	4.64	34.18	34.18	4.51
	62	50.26	44.05	3.27	46.66	42.03	3.60	43.09	40.02	3.94	39.52	37.98	4.28	36.06	36.06	4.64	34.18	34.18	4.51
	63*	51.28	36.22	3.27	47.58	34.38	3.60	43.89	32.55	3.94	40.18	30.72	4.28	36.42	28.87	4.64	34.30	27.73	4.51
	67	55.09	37.36	3.27	51.09	35.48	3.60	47.11	33.62	3.94	43.10	31.75	4.29	39.02	29.87	4.65	34.78	27.92	5.01
	72	60.45	30.62	3.26	56.04	28.88	3.60	51.64	27.15	3.95	47.22	25.42	4.30	42.71	23.67	4.67	40.74	22.84	4.59
1600 / 0.04	57	50.64	50.64	3.33	47.39	47.39	3.66	44.12	44.12	3.99	40.81	40.81	4.34	38.97	38.97	4.15	33.81	33.81	5.06
	62	51.54	47.47	3.33	47.82	45.31	3.66	44.17	43.97	3.99	40.81	40.81	4.34	38.97	38.97	4.15	33.81	33.81	5.06
	63*	52.46	38.62	3.33	48.59	36.69	3.66	44.75	34.79	4.00	40.90	32.88	4.34	38.86	31.74	4.15	32.95	28.95	5.05
	67	56.33	39.90	3.32	52.15	37.94	3.66	48.00	36.00	4.00	43.84	34.06	4.35	39.61	32.09	4.71	35.22	30.06	5.07
	72	61.77	32.23	3.32	57.17	30.43	3.66	52.59	28.64	4.00	48.00	26.86	4.36	43.32	25.05	4.72	38.45	23.18	5.08
1800 / 0.04	57	52.49	52.49	3.39	49.05	49.05	3.71	45.59	45.59	4.05	42.10	42.10	4.40	40.22	40.22	4.23	34.71	34.71	5.12
	62	52.66	50.62	3.39	49.04	49.04	3.71	45.59	45.59	4.05	42.09	42.09	4.40	38.49	38.49	4.76	36.60	36.60	4.65
	63*	53.37	40.93	3.39	49.37	38.93	3.71	45.40	36.94	4.05	41.44	34.96	4.40	37.42	32.94	4.75	33.28	30.85	5.11
	67	57.27	42.36	3.38	52.95	40.32	3.71	48.67	38.30	4.06	44.39	36.28	4.41	42.36	35.14	4.26	35.55	32.11	5.12
	72	62.77	33.77	3.37	58.02	31.92	3.71	53.29	30.08	4.06	48.56	28.24	4.42	43.75	26.38	4.78	38.76	24.47	5.14

PGN460 COOLING PERFORMANCE																			
EVAPORATOR AIR		CONDENSER ENTERING AIR TEMPERATURES °F (°C)																	
CFM / BF	Ewb	75 (23.9)			85 (29.4)			95 (35)			105 (40.6)			115 (46.1)			125 (51.7)		
		Capacity BTU/h x 1000		Total System kW	Capacity BTU/h x 1000		Total System kW	Capacity BTU/h x 1000		Total System kW	Capacity BTU/h x 1000		Total System kW	Capacity BTU/h x 1000		Total System kW	Capacity BTU/h x 1000		Total System kW
		Total	Sens		Total	Sens		Total	Sens		Total	Sens		Total	Sens		Total	Sens	
1750 / 0.03	57	62.31	62.31	3.82	57.76	57.76	4.31	53.24	53.24	4.85	48.73	48.73	5.45	44.19	44.19	6.12	39.54	39.54	6.85
	62	64.27	54.67	3.84	59.06	52.70	4.32	53.94	50.71	4.86	48.90	48.64	5.45	44.19	44.19	6.12	39.54	39.54	6.85
	63*	65.55	44.79	3.85	60.20	42.97	4.33	54.93	41.12	4.87	49.72	39.25	5.46	44.51	37.32	6.12	39.24	35.29	6.84
	67	70.43	46.23	3.90	64.67	44.38	4.38	59.00	42.51	4.92	53.38	40.61	5.51	47.75	38.65	6.17	42.05	36.58	6.89
	72	77.30	37.72	3.97	70.97	35.99	4.45	64.73	34.24	4.99	58.53	32.45	5.59	52.31	30.59	6.24	45.98	28.62	6.96
2000 / 0.04	57	65.10	65.10	3.93	60.26	60.26	4.42	55.46	55.46	4.96	50.67	50.67	5.57	45.84	45.84	6.24	40.90	40.90	6.97
	62	65.85	59.03	3.94	60.50	56.90	4.42	55.46	55.46	4.96	50.67	50.67	5.57	45.84	45.84	6.24	40.90	40.90	6.97
	63*	66.98	47.84	3.95	61.43	45.94	4.43	55.96	44.02	4.97	50.56	42.07	5.56	45.18	40.06	6.22	39.75	37.95	6.95
	67	71.92	49.46	4.00	65.94	47.53	4.48	60.07	45.59	5.02	54.26	43.62	5.62	48.44	41.58	6.28	42.56	39.43	6.99
	72	78.87	39.76	4.07	72.31	37.97	4.55	65.85	36.16	5.09	59.44	34.32	5.69	53.01	32.41	6.34	46.48	30.38	7.06
2250 / 0.04	57	67.45	67.45	4.04	62.36	62.36	4.53	57.30	57.30	5.07	52.27	52.27	5.68	47.19	47.19	6.35	42.00	42.00	7.08
	62	67.45	67.45	4.04	62.35	62.35	4.53	57.30	57.30	5.07	52.27	52.27	5.68	47.19	47.19	6.35	41.99	41.99	7.08
	63*	68.06	50.78	4.04	62.35	48.81	4.53	56.73	46.83	5.06	51.19	44.81	5.66	45.68	42.72	6.32	40.13	40.51	7.05
	67	73.04	52.59	4.09	66.90	50.60	4.58	60.86	48.59	5.12	54.90	46.55	5.72	48.94	44.43	6.38	42.93	42.19	7.09
	72	80.04	41.72	4.16	73.30	39.89	4.65	66.66	38.03	5.19	60.09	36.14	5.79	53.50	34.18	6.44	46.81	32.11	7.16

* 63°F Ewb is at 75°F entering dry bulb – Tennessee Valley Authority [TVA] rating conditions; all others at 80°F entering dry bulb.

LEGEND: BF — Bypass Factor Ewb — Entering Wet Bulb kW — Total Unit Power Input SHC — Sensible Heat Capacity (x1000 Btu/h) TC — Total Capacity (x1000 Btu/h) (net)

NOTES:

1. Ratings are net; they account for the effects of the evaporator fan motor power and heat.
2. Direct interpolation is permissible. Do not extrapolate.
3. The following formulas may be used:

$$t_{Ldb} = t_{Edb} - \frac{\text{Sensible Capacity (BTU/h)}}{1.10 \times \text{cfm}}$$

$$h_{Lwb} = h_{Ewb} - \frac{\text{Total Capacity (BTU/h)}}{4.5 \times \text{cfm}}$$

Where: h_{Ewb} = Enthalpy of air entering evaporator coil

t_{Lwb} = Wet bulb temperature corresponding to enthalpy of air leaving evaporator coil (h_{Lwb})

4. The SHC is based on 80°F Edb temperature of air entering evaporator coil.
Below 80°F Edb, subtract (corr factor x cfm) from SHC.
Above 80°F Edb, add (corr factor x cfm) to SHC. Correction Factor = $1.10 \times (1 + BF) \times (Edb + 80)$.

ACCESSORIES

ROOF CURBS

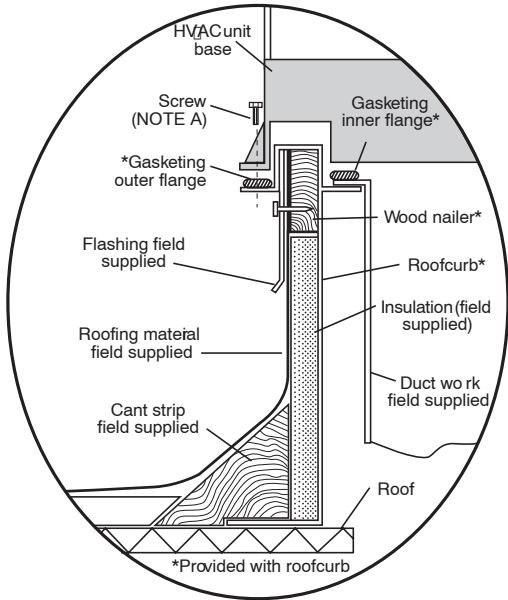

Roof Curb for Small Cabinet

Note A: When unit mounting screw is used, retainer bracket must also be used.

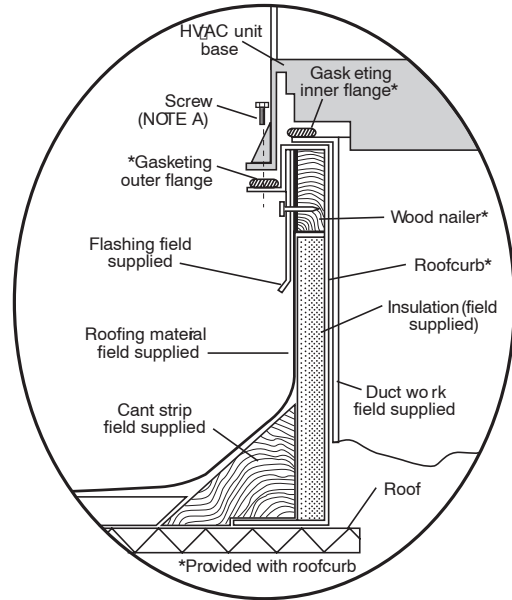

Roof Curb for Large Cabinet

Note A: When unit mounting screw is used, retainer bracket must also be used.

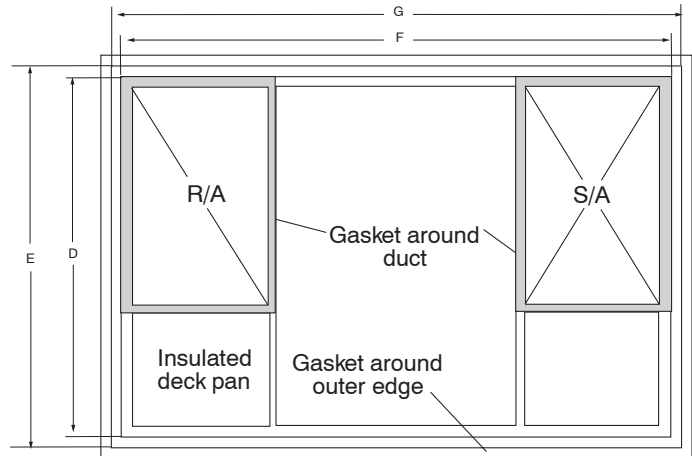
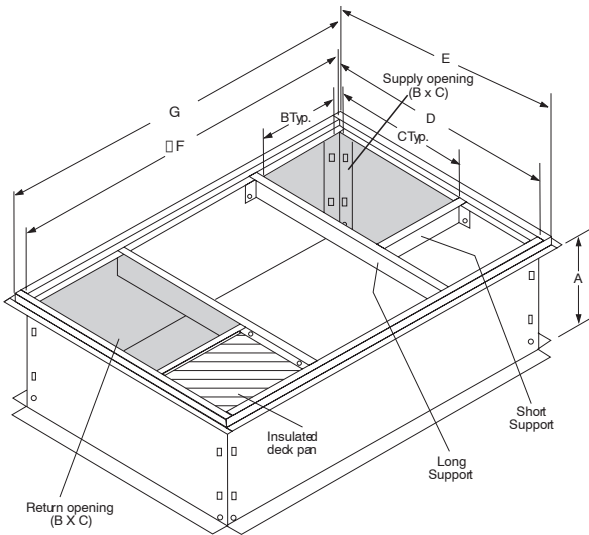

UNIT SIZE	MODEL NUMBER	A IN. [MM]	B IN. [MM]	C IN. [MM]	D IN. [MM]	E IN. [MM]	F IN. [MM]	G IN. [MM]
24, 30, 36	NPRFCURB006A00	8 [203]	11 [279]	16-1/2 [419]	28-3/4 [730]	30-3/8 [771]	44-5/16 [1126]	45-15/16 [1167]
	NPRFCURB007A00	14 [356]	11 [279]	16-1/2 [419]	28-3/4 [730]	30-3/8 [771]	44-5/16 [1126]	45-15/16 [1167]
42, 48, 60	NPRFCURB008A00	8 [203]	16-3/16 [411]	17-3/8 [441]	40-1/4 [1022]	41-15/16 [1065]	44-7/16 [1129]	46-1/16 [1169]
	NPRFCURB009A00	14 [356]	16-3/16 [411]	17-3/8 [441]	40-1/4 [1022]	41-15/16 [1065]	44-7/16 [1129]	46-1/16 [1169]

Notes:

1. Seal strip must be applied as required to unit being installed.
2. Roof curb is made of 16 gauge steel.
3. Attach ductwork to curb (flanges of duct rest on curb).
4. Insulated panels: 1-in. thick fiberglass 1 lb. density.
5. When unit mounting screw is used (see Note A), a retainer bracket must be used as well. This bracket must also be used when required by code for hurricane or seismic conditions. This bracket is available through Micrometl.

ACCESSORIES (continued)

ROOF CURBS

Model Number	Description	Use With Model Size
NPRFCURB006A00	8" High Roof Curb	24, 30, 36
NPRFCURB007A00	14" High Roof Curb	24, 30, 36
NPRFCURB008A00	8" High Roof Curb	42, 48, 60
NPRFCURB009A00	14" High Roof Curb	42, 48, 60

ECONOMIZERS

Model Number	Description	Use With Model Size
NPECOMZR003A00	Vertical or Horizontal, internal with solid state controller, fully modulating damper, up to 50% barometric relief *, supply and dry bulb outdoor air sensors, filter rack with 1-inch filters.**	24, 30, 36
NPECOMZR004A00		42
NPECOMZR006A00		48, 60
AXB078ENT	Outdoor Enthalpy Control	ALL

* Barometric relief only works in the down discharge application

** Outdoor enthalpy available as field installed accessory

MANUAL FRESH AIR DAMPERS

Model Number	Description	Use With Model Size
NPMANDPR004A00	Manual Outside Air Damper – External w/ filter rack and 1" filter	24, 30, 36
NPMANDPR005A00		42
NPMANDPR006A00		48, 60

INTERNAL FILTER RACK and FILTER (shipped with 1" filters)

Model Number	Description	Filter Size	Use With Model Size
NPFILTRK004A00	Horizontal or Downflow Internal Filter Rack	12" x 20" x 1" (quan. 2) or 12" x 20" x 2" (quan. 1) PLUS 10" x 20" x 2" (quan.1)	24, 30, 36
NPFILTRK005A00		12" x 24" x 1" or 2" (3 required)	42
NPFILTRK006A00		12" x 24" x 1" or 2" (3 required)	48, 60

CONCENTRIC DIFFUSER & DUCT TRANSITIONS

Model Number	Description	Use With Model Size
AXB030CSA	STEP DOWN – Fits 2' x 4' Ceiling Grid (Adpats round 18" duct)	ALL
AXB030CFA	FLUSH MOUNT – Fits 2' x 4' Ceiling Grid (Adapts round 18" duct)	ALL
NPDUCLG002A00	Square (14" x 16") to Round (14") – 1 set of 2, use with curb	30, 36, 42, 48

CRANKCASE HEATER (Factory installed on 36 and 60)

Model Number	Description – Belly Band type electric heater	Use With Model Size
NPCRKHTR008A00	240V Crankcase Heater	24, 30
NPCRKHTR004A00	240V Crankcase Heater	42, 48

HIGH AND LOW PRESSURE SWITCH KIT, LOW AMBIENT, ANTI-CYCLE TIMER, COMPRESSOR START ASSIST

Model Number	Description	Use With Model Size
AXB035LAA	Low ambient Control – enables cooling system to operate down to 0 Deg. F by cycling condenser fan on and off	ALL
NRTIMEGD001A00	5 minute anti-cycle timer (Note: many thermostats have inherent anti-cycle timer logic)	ALL
NPHSTART001A00	PTC type compressor start assist	ALL

GAS CONVERSION KITS

Model Number	Description	Use With Model Size
NPLPCONV011A00	Natural Gas to Propane Conversion Kit (0 – 2000')	ALL
NPLPCONV012A00	Natural Gas to Propane Conversion Kit (2001' – 6000')	
NPNGCONV003A00	Propane to Natural Gas Conversion Kit (0 – 2000')	

FLUE DISCHARGE DEFLECTOR

Model Number	Description	Heat Input (BTU/h)
NRFLUEDS001A00	Directs flue gas exhaust 90 degrees upward from current discharge. Designed to allow tighter distances between unit and combustible surfaces. 24 inch Height. AGA certified.	40,000 – 130,000

LIFTING / RIGGING KIT

Model Number	Description	Use With Model Size
NPLIFTBK003A10	For Rooftop Applications (Set of 10)	ALL

UNIT DIMENSIONS, model sizes 24, 30, 36

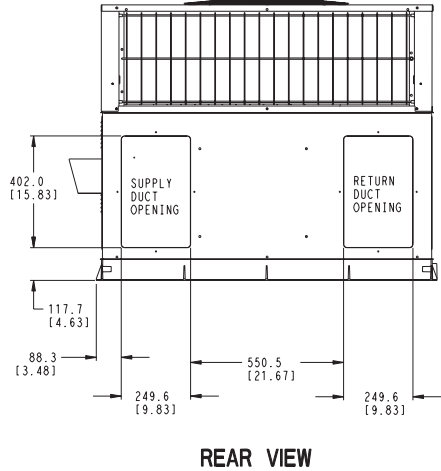
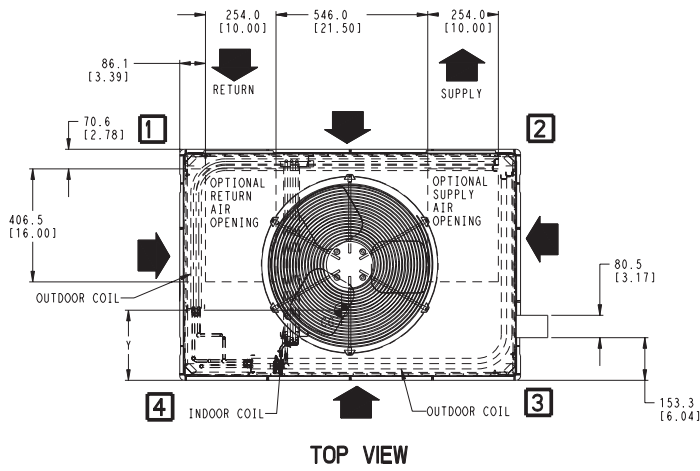

REQUIRED CLEARANCES TO COMBUSTIBLE MATL.

	MILLIMETERS [IN]
TOP OF UNIT.....	355.6 [14.00]
DUCT SIDE OF UNIT.....	50.8 [2.00]
SIDE OPPOSITE DUCTS.....	355.6 [14.00]
BOTTOM OF UNIT.....	12.7 [0.50]
FLUE PANEL.....	914.4 [36.00]

NEC. REQUIRED CLEARANCES.

	MILLIMETERS [IN]
BETWEEN UNITS, POWER ENTRY SIDE.....	1066.8 [42.00]
UNIT AND UNGROUNDED SURFACES, POWER ENTRY SIDE.....	914.0 [36.00]
UNIT AND BLOCK OR CONCRETE WALLS AND OTHER GROUNDED SURFACES, POWER ENTRY SIDE.....	1066.8 [42.00]

REQUIRED CLEARANCE FOR OPERATION AND SERVICING

	MILLIMETERS [IN]
EVAP. COIL ACCESS SIDE.....	914.0 [36.00]
POWER ENTRY SIDE.....	1066.8 [42.00]
(EXCEPT FOR NEC REQUIREMENTS)	
UNIT TOP.....	1219.2 [48.00]
SIDE OPPOSITE DUCTS.....	914.0 [36.00]
DUCT PANEL.....	304.8 [12.00]*

*MINIMUM DISTANCES: IF UNIT IS PLACED LESS THAN 304.8 [12.00] FROM WALL SYSTEM, THEN SYSTEM PERFORMANCE MAYBE COMPROMISED.

DIMENSIONS IN [] ARE IN INCHES

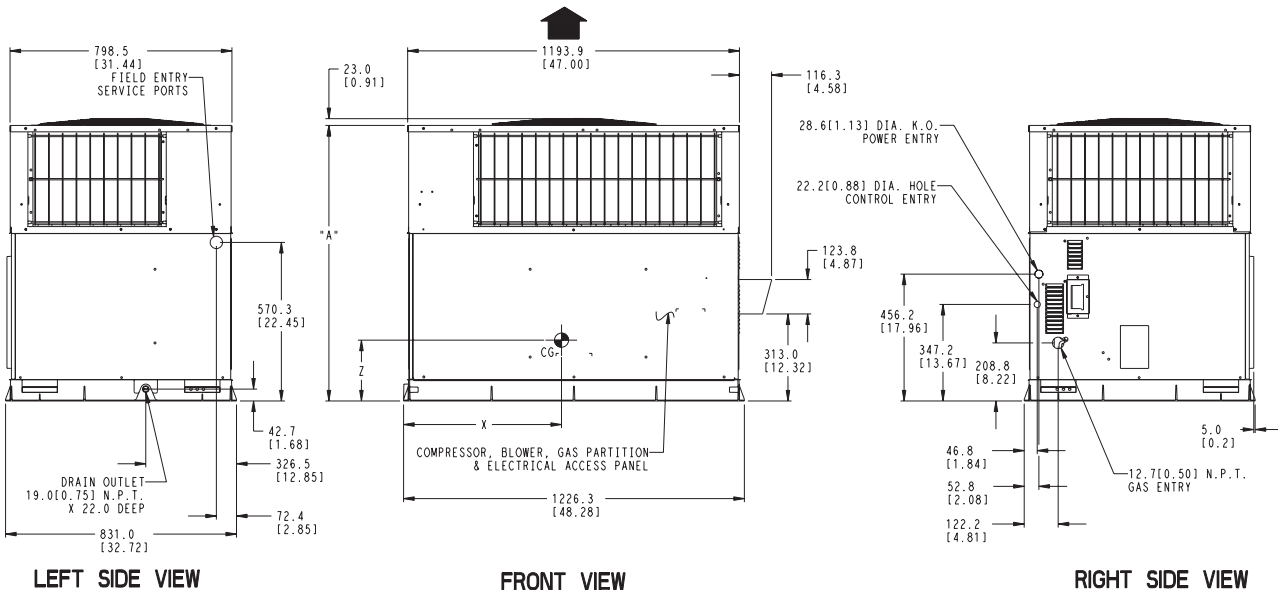

Model Size	UNIT HEIGHT	CENTER OF GRAVITY			
	inches [mm]	inches [mm]			
	A	X	Y	Z	
24	37.02 [940]	23.6 [599.4]	15.8 [401.3]	15.7 [398.8]	
30	37.02 [940]	23.6 [599.4]	15.8 [401.3]	15.7 [398.8]	
36	43.02 [1093]	25.0 [635]	15.9 [403.9]	16.0 [406.4]	

UNIT DIMENSIONS, model sizes 42, 48, 60

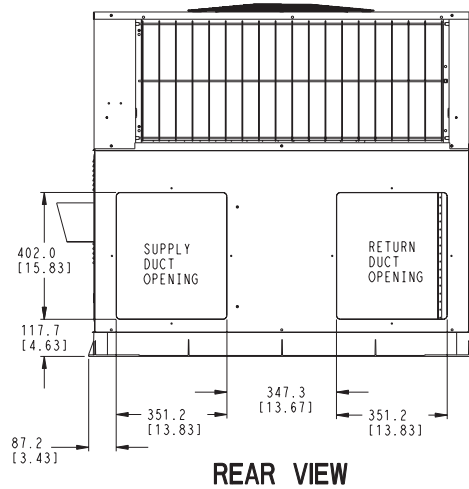
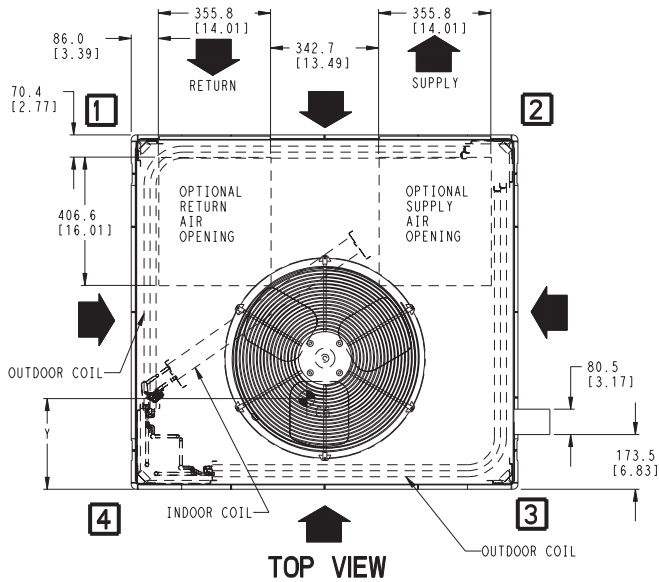

REQUIRED CLEARANCES TO COMBUSTIBLE MATL.

	MILLIMETERS [IN]
TOP OF UNIT.....	355.6 [14.00]
DUCT SIDE OF UNIT.....	50.8 [2.00]
SIDE OPPOSITE DUCTS.....	355.6 [14.00]
BOTTOM OF UNIT.....	12.7 [0.50]
FLUE PANEL.....	914.4 [36.00]

NEC. REQUIRED CLEARANCES.

	MILLIMETERS [IN]
BETWEEN UNITS, POWER ENTRY SIDE.....	1066.8 [42.00]
UNIT AND UNGROUNDED SURFACES, POWER ENTRY SIDE.....	914.0 [36.00]
UNIT AND BLOCK OR CONCRETE WALLS AND OTHER GROUNDED SURFACES, POWER ENTRY SIDE.....	1066.8 [42.00]

REQUIRED CLEARANCE FOR OPERATION AND SERVICING

	MILLIMETERS [IN]
EVAP. COIL ACCESS SIDE.....	914.0 [36.00]
POWER ENTRY SIDE.....	1066.8 [42.00]
(EXCEPT FOR NEC REQUIREMENTS)	
UNIT TOP.....	1219.2 [48.00]
SIDE OPPOSITE DUCTS.....	914.0 [36.00]
DUCT PANEL.....	304.8 [12.00]

*MINIMUM DISTANCES: IF UNIT IS PLACED LESS THAN 304.8 [12.00] FROM WALL SYSTEM, THEN SYSTEM PERFORMANCE MAYBE COMPROMISED.

DIMENSIONS IN [] ARE IN INCHES

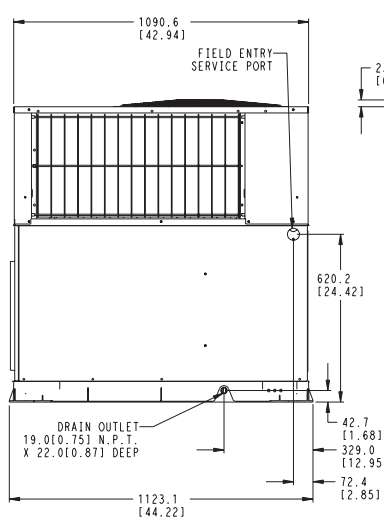

LEFT SIDE VIEW

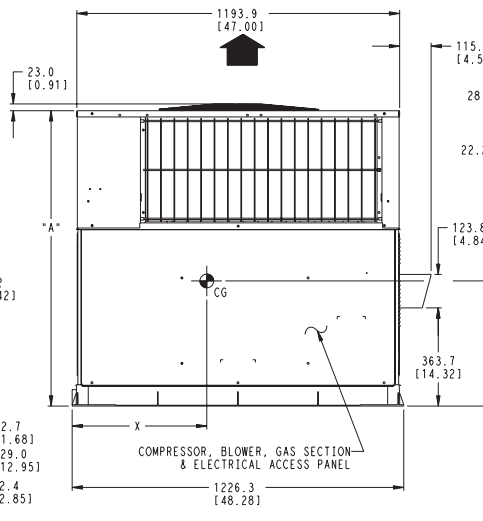

FRONT VIEW

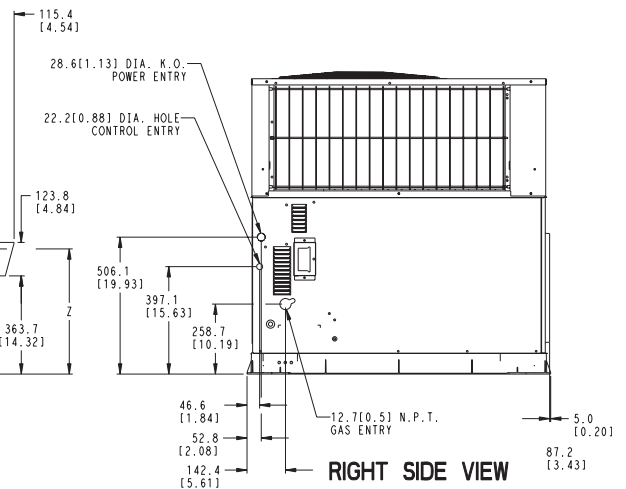

RIGHT SIDE VIEW

Model Size	UNIT HEIGHT	CENTER OF GRAVITY		
	inches [mm]	A	X	Y
42	46.98 [1193]	25.5 [647.7]	21.0 [533.4]	17.6 [447.0]
48	46.98 [1193]	25.7 [652.8]	21.8 [553.7]	18.0 [457.2]
60	50.98 [1295]	25.8 [655.3]	22.0 [558.8]	20.0 [508.0]

GUIDE SPECIFICATIONS

CABINET

Unit cabinet shall be constructed of phosphated, zinc-coated, pre-painted steel capable of with-standing 500 hours in salt spray. Normal service shall be through a single removable cabinet panel.

The unit shall be constructed on a rust proof unit base that has an externally trapped, integrated sloped drain.

Evaporator fan compartment top surface shall be insulated with a minimum 1/2-in. thick, flexible fiberglass insulation, coated on the air side and retained by adhesive and mechanical means. The evaporator wall sections will be insulated with a minimum semi-rigid foil-faced board capable of being wiped clean. Aluminum foil-faced fiberglass insulation shall be used in the entire indoor air cavity section.

COOLING SECTION

The unit is factory charged and operationally ready upon delivery. The unit refrigerant circuit has a high efficiency scroll compressor with internal overload protection, and copper tube / aluminum fin evaporator and condenser coils. The unit is designed for cooling operation to 40° F and will be capable of being wired for field installed economizer type accessories.

COILS

The evaporator and condenser coils are fabricated with aluminum fins mechanically bonded to copper tubing. Both coils are pressure tested prior to assembly into the unit and electronically leak tested after assembly into the unit.

CONDENSER FAN

The unit has a single direct-drive propeller-fan / motor assembly. The assembly is mounted directly to a vertical-discharge grille that is easily removed for service. Motors are 825 – 1100 RPM with sleeve or ball bearings and internal overload protection.

EVAPORATOR BLOWER

All units have a direct-drive X-13 evaporator blower motor as a standard. The direct-drive evaporator blower motor has sleeve bearings and internal overload protection.

HEATING SECTION

The gas-fired heating section features an induced draft blower for combustion air. The unit has an tubular aluminized steel heat exchanger located on the discharge air side of the blower. The system uses in-shot burners ignited by a direct spark ignition system, protected by both a high heat limit switch and flame roll-out switch. The induced draft blower motor is interlocked with a pressure switch safety device.

CORNER WEIGHTS and RIGGING DETAILS

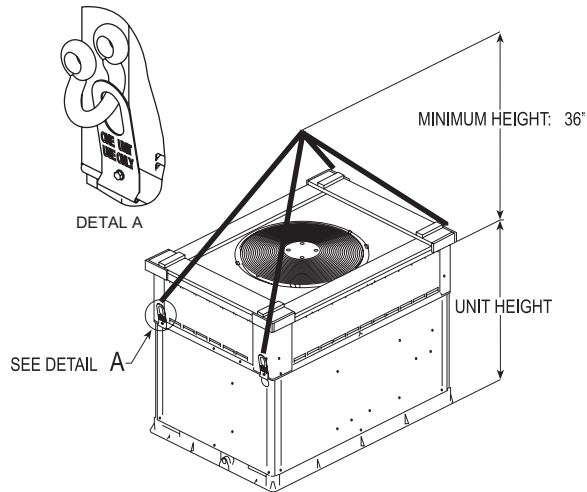
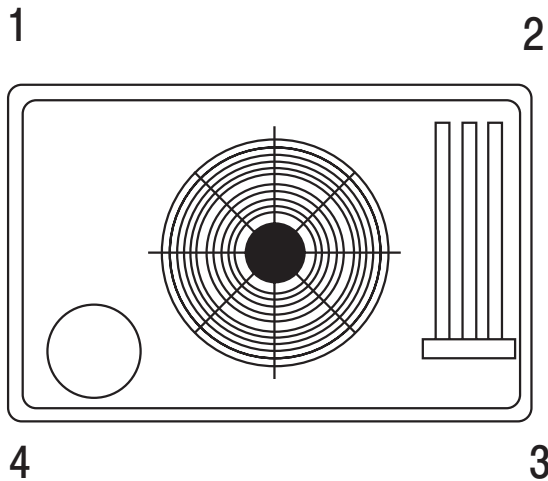

C00070b

A06361

CORNER WEIGHTS (SMALL CABINET)						
Model Size	24		30		36	
	lbs	kg	lbs	kg	lbs	kg
Operating Weight	307	139.2	319	144.7	353	160.1
Corner Weight 1	62	28.1	65	29.5	49	22.2
Corner Weight 2	87	39.5	90	40.8	106.5	48.3
Corner Weight 3	82	37.2	85	38.6	71.5	32.4
Corner Weight 4	76	34.5	79	35.8	126	57.2
Shipping Weight	361	163.7	373	169.2	407	184.6

CORNER WEIGHTS (LARGE CABINET)						
Model Size	42		48		60	
	lbs	kg	lbs	kg	lbs	kg
Operating Weight	435	197.3	453	205.5	481	218.2
Corner Weight 1	62.8	28.5	67.3	30.5	68.7	31.2
Corner Weight 2	166.7	75.6	171.2	77.7	184	83.5
Corner Weight 3	89.9	40.8	94.4	42.8	94.9	43.0
Corner Weight 4	115.6	52.4	120.1	54.5	133.4	60.5
Shipping Weight	497	225.4	515	233.6	543	246.3

MODEL NOMENCLATURE										
MODEL SERIES	P	G	N	4	36	090	K	00	A	1
P = Package										
G = Gas/Electric										
N = R-410A										
4 = 14										
24 = 24,000 BTUH = 2 Tons										
30 = 30,000 BTUH = 2.5 Tons										
36 = 36,000 BTUH = 3 Tons										
42 = 36,000 BTUH = 3.5 Tons										
48 = 48,000 BTUH = 4 Tons										
60 = 60,000 BTUH = 5 Tons										
040 = 40,000										
060 = 60,000										
090 = 90,000										
115 = 115,000										
130 = 130,000										
K = 208/230-1-60										
00 = Standard										
01 = Low NOx										
Sales Model Digit										
Engineering Digit										