

### HIGH EFFICIENCY PACKAGE GAS HEATING/ELECTRIC COOLING, R-410A SINGLE PACKAGE ROOFTOP 15 – 25 TONS

#### BUILT TO LAST, EASY TO INSTALL AND SERVICE

- One-piece, high efficiency gas heating and electric cooling with a low profile, prewired, tested, and charged at the factory
- Dedicated vertical or horizontal air flow duct configuration models. No field kits required.
- Full perimeter base rail with built-in rigging adapters and fork truck slots
- Pre-painted exterior panels and primer-coated interior panels tested to 500 hours salt spray protection
- Fully insulated cabinet
- Two-stage cooling with independent circuits and control on all models
- Redundant gas valve for two stage gas heating capacity control
- Exclusive IGC solid-state control for on-board diagnostics with LED error code designation, burner control logic and energy saving indoor fan motor delay
- High efficiency, gas heat with induced draft flue exhaust design
- Scroll compressors on all models
- All units have high and low pressure switches
- Two inch disposable fiberglass type return air filters in dedicated rack with tool-less filter access door
- Refrigerant circuits contain a liquid line filter drier to trap dirt and moisture
- Exclusive non-corrosive composite condensate pan in accordance with ASHRAE 62 Standard, sloping design; end drain
- Belt drive evaporator-fan motor and pulley combinations available to meet most applications
- Access panels with easy grip handles provide quick and easy access to the blower and blower motor, control box, and compressors.
- “No-strip” screw system has superior holding power and guides screws into position while preventing the screw from stripping the unit’s metal.
- Newly designed terminal board facilitates simple safety circuit troubleshooting and simplified control box arrangement
- Standard outdoor temperature cooling operation range up to 125°F (52°C) and down to 35°F (2°C)
- TXV metering devices on all models to precisely control refrigerant flow
- Large, laminated control wiring and power wiring drawings are affixed to unit to make troubleshooting easy
- Capable of thru-the-base or thru-the-curb gas line routing
- Single point gas and electrical connections



15 Ton



As an Energy Star® Partner, International Comfort Products has determined that this product meets the ENERGY STAR® guidelines for energy efficiency.



Use of the AHRI Certified TM Mark indicates a manufacturer’s participation in the program. For verification of certification for individual products, go to [www.ahridirectory.org](http://www.ahridirectory.org).



#### WARRANTY

- 15 Year limited warranty on optional stainless steel heat exchanger.
- 10 Year limited warranty on aluminized stainless steel heat exchanger
- 5 Year compressor limited warranty
- 1 Year parts limited warranty

UNIT PERFORMANCE DATA – Two Stage Cooling								
UNIT	Dedicated Airflow	Nominal Tons	COOLING		GAS HEATING		Unit Dimensions H x W x L	Unit Weight lb. [kg]
			Net Cap. (Btuh)	EER	Input Cap. (Btuh) Stage 2	Thermal Efficiency %		
RGH181*^AA0AAA	Vertical	15	174,000	12.0	220,000 - 400,000	81.0	49-3/8" x 86-3/8" x 127-7/8"	1892 [860]
RGH183*^AA0AAA	Horizontal	15	174,000	12.0	220,000- 400,000	81.0	49-3/8" x 86-3/8" x 127-7/8"	1892 [860]
RGH210*^AA0AAA	Vertical	17.5	202,000	12.0	220,000 - 400,000	81.0	49-3/8" x 86-3/8" x 141-1/2"	2102 [956]
RGH213*^AA0AAA	Horizontal	17.5	202,000	12.0	220,000 - 400,000	81.0	49-3/8" x 86-3/8" x 141-1/2"	2102 [956]
RGH240*^AA0AAA	Vertical	20	236,000	12.0	220,000 - 400,000	81.0	57-3/8" x 86-3/8" x 141-1/2"	2247 [1021]
RGH243*^AA0AAA	Horizontal	20	236,000	12.0	220,000 - 400,000	81.0	57-3/8" x 86-3/8" x 141-1/2"	2247 [1021]
RGH300*^AA0AAA	Vertical	25	282,000	11.2	220,000 - 400,000	81.0	57-3/8" x 86-3/8" x 157-3/4"	2193 [997]
RGH303*^AA0AAA	Horizontal	25	282,000	11.2	220,000 - 400,000	81.0	57-3/8" x 86-3/8" x 157-3/4"	2193 [997]

\* Indicates Unit voltage: H = 208/230-3-60, L = 460-3-60, S = 575-3-60

^ See model nomenclature listing for gas heating options.

**NOTE: BASE MODEL NUMBERS LISTED. SEE MODEL NOMENCLATURE LISTING FOR ADDITIONAL OPTIONS**

# TABLE OF CONTENTS

	PAGE		PAGE
MODEL NUMBER NOMENCLATURE .....	3	COOLING TABLES .....	24
FACTORY OPTIONS AND/OR ACCESSORIES .....	4	STATIC PRESSURE ADDERS .....	28
AHRI COOLING RATING TABLE .....	8	FAN PERFORMANCE .....	29
HEAT RATING TABLES .....	9	OUTDOOR AIR INTAKE & EXHAUST PERF .....	34
SOUND PERFORMANCE TABLE .....	9	ELECTRICAL INFO .....	35
PHYSICAL DATA .....	10	MCA / MOCP .....	37
CURBS & WEIGHTS DIMENSIONS .....	13	TYPICAL WIRING DIAGRAMS .....	39
APPLICATION DATA .....	23	SEQUENCE OF OPERATION .....	41
		GUIDE SPECIFICATIONS .....	42

# MODEL NOMENCLATURE

MODEL SERIES	R	G	H	1	8	1	H	D	A	B	0	A	A	A
Position Number	1	2	3	4	5	6	7	8	9	10	11	12	13	14
R = Rooftop														
G = Gas/Electric <span style="float: right;">Type</span>														
H = High Efficiency <span style="float: right;">Efficiency</span>														
181 = 181,000 = 15 Tons Dedicated Vertical SA/RA (SA = Supply Air, RA = Return Air)														
183 = 180,000 = 15 Tons Dedicated Horizontal SA/RA														
210 = 210,000 = 17.5 Tons Dedicated Vertical SA/RA														
213 = 210,000 = 17.5 Tons Dedicated Horizontal SA/RA														
240 = 240,000 = 20 Tons Dedicated Vertical SA/RA														
243 = 240,000 = 20 Tons Dedicated Horizontal SA/RA														
300 = 300,000 = 25 Tons Dedicated Vertical SA/RA														
303 = 300,000 = 25 Tons Dedicated Horizontal SA/RA <span style="float: right;">Nominal Cooling Capacity</span>														
H = 208/230-3-60														
L = 460-3-60														
S = 575-3-60 <span style="float: right;">Voltage</span>														
D = Low Heat														
E = Medium Heat														
F = High Heat														
S = Low Heat, Stainless Steel Heat Exchanger														
R = Medium Heat, Stainless Steel Heat Exchanger														
T = High Heat, Stainless Steel Heat Exchanger <span style="float: right;">Heating Capacity</span>														
A = Standard Motor														
C = Medium Static Motor														
B = High Static Motor														
E = High Static - High Efficiency Motor														
F = Medium Static - High Efficiency Motor <span style="float: right;">Motor Option</span>														
A = None														
B = Economizer w/Baro-relief, OA Temp sensor														
E = Economizer w/Baro-relief + CO <sub>2</sub> sensor, OA Temp sensor														
H = Economizer w/Baro-relief, Enthalpy sensor														
L = Economizer w/Baro-relief + CO <sub>2</sub> sensor, Enthalpy sensor														
P = 2-Position damper w/Baro-relief <span style="float: right;">Outdoor Air Options / Control</span>														
0A = No Options														
4B = Non-Fused Disconnect														
AT = Non-powered 115v C.O.														
BR = Supply Air Smoke Detector														
BA = Supply Air Smoke Detector + Non-Powered 115v C.O.														
7C = Non-Fused Disconnect + Non-Powered 115v C.O.														
7K = Non-Fused Disconnect + Non-Powered 115v C.O.+ SA Smoke detector														
8A = Non-Fused Disconnect + SA Smoke detector														
AA = Easy Access Hinged Panels														
6C = Non-Fused Disconnect + Easy Access Hinged Panels														
6D = Non-Fused Disconnect + Easy Access Hinged Panels + Non-powered 115V C.O.														
6L = Non-Fused Disconnect + Easy Access Hinged Panels + Non-powered 115V C.O. + SA Smoke detector														
7B = Non-Fused Disconnect + Easy Access Hinged Panels + SA Smoke detector														
AB = Easy Access Hinged Panels + Non-powered 115v C.O.														
AJ = Easy Access Hinged Panels + Non-powered 115v C.O. + SA Smoke detector														
CH = Easy Access Hinged Panels + SA Smoke detector <span style="float: right;">Factory Installed Options</span>														
A = Aluminum/Copper Cond & Evap Coil														
B = Precoat Aluminum/Copper Cond & Alum/Copper Evap Coil														
C = E-Coated Aluminum/Copper Cond & Alum/Copper Evap Coil														
D = E-Coated Aluminum/Copper Cond & Evap Coil														
E = Copper/Copper Cond & Aluminum/Copper Evap														
F = Copper/Copper Cond & Evap <span style="float: right;">Condenser / Evaporator Coil Configuration</span>														
A = Original Design														Sales Code

**Table 1 – FACTORY INSTALLED OPTIONS AND FIELD INSTALLED ACCESSORIES**

CATEGORY	ITEM	FACTORY INSTALLED OPTION	FIELD INSTALLED ACCESSORY
<b>Cabinet</b>	Dedicated Vertical Air Flow Duct Configuration	X	
	Dedicated Horizontal Air Flow Duct Configuration	X	
	Hinged Access Panels	X	
<b>Coil Options</b>	Copper/Copper (indoor) coils	X	
	E-coated outdoor coils	X	
<b>Condenser Protection</b>	Condenser coil hail guard (louvered design)		X
<b>Controls</b>	Smoke detector (supply air)	X	
	Time Guard II compressor delay control circuit		X
	Phase Monitor		X
<b>Economizers &amp; Outdoor Air Dampers</b>	Economizer	X	X
	Motorized 2 position outdoor-air damper	X	X
	Manual outdoor-air damper (25%)		X
	Barometric relief <sup>1</sup>	X	X
	Barometric hood (Horizontal economizer)		X
	Power exhaust-centrifugal blower		X
<b>Economizer Sensors &amp; IAQ Devices</b>	Single dry bulb temperature sensors <sup>2</sup>	X	X
	Single enthalpy sensors <sup>2</sup>	X	X
	Differential enthalpy sensors <sup>2</sup>		X
	Duct mounted CO <sub>2</sub> sensor <sup>2</sup>		X
	4-in Filter Track Assembly		X
<b>Gas Heat</b>	Propane conversion kit		X
	Stainless steel heat exchanger	X	
	High altitude conversion kit		X
	Flue Discharge Deflector		X
<b>Indoor Motor &amp; Drive</b>	Multiple motor and drive packages	X	
<b>Low Ambient Control</b>	Winter start kit <sup>3</sup>		X
	Motormaster head pressure controller <sup>3</sup>		X
<b>Power Options</b>	Convenience outlet (unpowered)	X	
	Non-fused disconnect	X	
<b>Roof Curbs</b>	Roof curb 14-in (356mm)		X
	Roof curb 24-in (610mm)		X

**NOTES:**

1. Included with economizer.
2. Sensors used to optimize economizer performance.
3. See application data for assistance.
4. Non-fused disconnect switch cannot be used when MOCP electrical rating exceeds 70 amps at 460/575 volt and 150 amps at 208/230 volt.

**FACTORY OPTIONS AND/OR ACCESSORIES**

**Economizer (dry-bulb or enthalpy)**

Economizers save money. They bring in fresh, outside air for ventilation; and provide cool, outside air to cool your building. This is the preferred method of low-ambient cooling. When coupled to CO<sub>2</sub> sensors, economizers can provide even more savings by coupling the ventilation air to only that amount required.

Economizers are available, installed and tested by the factory, with either enthalpy or dry-bulb temperature inputs. Additional sensors are available as accessories to optimize the economizers.

Economizers include gravity controlled, barometric relief equalizes building pressure and ambient air pressures. This can be a cast effective solution to prevent building pressurization. If further control of exhaust air is required, a dual centrifugal fan power exhaust system is also available.

**CO<sub>2</sub> Sensor**

Improves productivity and saves money by working with the economizer to intake only the correct amount of outside air for ventilation. As occupants fill your building, the CO<sub>2</sub> sensor detects their presence through increasing CO<sub>2</sub> levels, and opens the economizer appropriately.

When the occupants leave, the CO<sub>2</sub> levels decrease, and the sensor appropriately closes the economizer. This intelligent control of the ventilation air, called Demand Control Ventilation (DCV) reduces the overall load on the rooftop, saving money.

## FACTORY OPTIONS AND/OR ACCESSORIES (CONT.)

### Smoke Detector

Smoke detectors make your application safer and your job easier. Smoke detectors immediately shut down the rooftop unit when smoke is detected. It is available for supply air.

### Louvered Hail Guards (accessory only)

Sleek, louvered panels protect the condenser coil from hail damage, foreign objects, and incidental contact.

### Convenience Outlet (un-powered)

Reduce service and/or installation costs by including a convenience outlet in your specification. The convenience outlet provides, 15 amp, 115v GFCI receptacle with "Wet in Use" cover. This option is to be powered from a separate 115/120v power source.

### Non-Fused Disconnect

This OSHA-compliant, factory-installed, safety switch allows a service technician to locally secure power to the rooftop capable of providing protection to a MOCP maximum of 200A.

### Power Exhaust with Barometric Relief

Superior internal building pressure control. This field-installed accessory may eliminate the need for costly, external pressure control fans.

### Time Guard II Control Circuit

This accessory protects your compressor by preventing short-cycling in the event of some other failure, prevents the compressor from restarting for 30 seconds after stopping.

### Filter or Fan Status Switches (accessory only)

Use these differential pressure switches to detect a filter clog or indoor fan motor failure. When used in conjunction with a compatible unit controller/thermostat, the switches will activate an alarm to warn the appropriate personnel.

### Motorized 2-Position Damper

The new 2-position, motorized outdoor air damper admits up to 100% outside air. Using reliable, gear-driven technology, the 2-position damper opens to allow ventilation air and closes when the rooftop stops, stopping unwanted infiltration.

### Manual OA Damper (accessory only)

Manual outdoor air dampers are an economical way to bring in ventilation air. The dampers are available in 25% versions.

### Motormaster Head Pressure Controller

The Motormaster motor controller is a low ambient, head pressure controller kit that is designed to maintain the unit's condenser head pressure during periods of low ambient cooling operation. This device should be used as an alternative to economizer free cooling not when economizer usage is either not appropriate or desired. The Motormaster will either cycle the outdoor-fan motors or operate them at reduced speed to maintain the unit operation, depending on the model.

### Winter Start Kit (accessory only)

The winter start kit extends the low ambient limit of your rooftop to 25°F (-4°C). The kit bypasses the low pressure switch, preventing nuisance tripping of the low pressure switch. Other low ambient precautions may still be prudent.

### Propane Heating (accessory only)

Convert your gas heat rooftop from standard natural gas operation to propane using this field-installed kit.

### High Altitude Heating (accessory only)

High altitudes have less oxygen, which means heat exchangers need less fuel. The new gas orifices in this field-installed kit make the necessary adjustment for high altitude applications. They restore the optimal fuel to air mixture and maintain healthy combustion at altitudes above 2000 ft (610m). Kits may not be required in all areas.

### Optional Stainless Steel Heat Exchanger

The stainless steel heat exchanger option provides the tubular heat exchanger be made out of a minimum 20 gauge type 409 stainless steel for applications where the mixed air to the heat exchanger is expected to drop below 45°F (7°C). Stainless steel may be specified on applications where the presence of airborne contaminants require its use or in area with very high outdoor humidity that may result in severe condensation in the heat exchanger during cooling operation.

### Flue Discharge Deflector (accessory only)

The flue discharge deflector is a useful accessory when flue gas recirculation is a concern. By venting the flue discharge upwards, the deflector minimizes the chance for a neighboring unit to intake the flue exhaust.

### Alternate Motors and Drives

Some applications need larger horsepower motors, some need more airflow, and some need both. A wide selection of motors and pulleys (drives) are available, factory installed, to handle nearly any application.

### Barometric Hood (accessory only)

For Horizontal Economizer applications where relief damper is installed in duct work. This kit provides the needed protection.

### Hinged Access Panels

Allows access to unit's major components with specifically designed hinged access panels. Panels are filter, control box, indoor fan motor.

## ACCESSORIES – RGH181–303

FLAT ROOF CURBS*		
Model Number	Description	Use With Model Size
CRRFCURB045A00	14" High Roof Curb	181/183
CRRFCURB047A00	14" High Roof Curb	210/213 – 240/243
CRRFCURB046A00	24" High Roof Curb	181/183
CRRFCURB048A00	24" High Roof Curb	210/213 – 240/243
CRRFCURB049A00	14" High Roof Curb	300/303
CRRFCURB050A00	24" High Roof Curb	300/303

\* Includes thru-the-bottom capability

ECONOMIZERS		
Model Number	Description	Use With Model Size
DNECOMZR052A00	Vertical & Horizontal with solid state controller (W7212)	181/183 – 210/213
DNECOMZR053A00	Vertical & Horizontal with solid state controller (W7212)	240–243 – 300/303

ECONOMIZER SENSORS		
Model Number	Description	Use With Model Size
DNTEMPSN002A00	Single (dry bulb) Control	ALL Economizers With W7212 Contoller
DNCBDIOX005A00	CO2 Sensor and aspirator box for use in return air stream.	ALL Economizers With W7212 Contoller
DNENTDIF004A00	Return Air Enthalpy Sensor for use with AXB078ENT for differential enthalpy control	ALL Economizers With W7212 Contoller
AXB078ENT	Differential Enthalpy Control Upgrade	ALL

BAROMETRIC RELIEF HOOD		
Model Number	Description	Use With Model Size
CRBARHOD001A00	For horizontal economizer applications where relief damper is installed in duct work, this kit provides needed protection	183 – 213 – 243 – 303

POWER EXHAUST*		
Model Number	Description	Use With Model Size
CRPWREXH068A00	Vertical and Horizontal, 208/230–3–60	181/183–210/213–240/243–300/303
CRPWREXH069A00	Vertical and Horizontal, 460–3–60	181/183–210/213–240/243–300/303
CRPWREXH070A00	Vertical and Horizontal, 575–3–60	181/183–210/213–240/243–300/303

MANUAL OUTDOOR AIR DAMPERS		
Model Number	Description	Use With Model Size
CRMANDPR009A00	25% Open Manual Fresh Air Damper	181/183 – 210/213
CRMANDPR010A00	25% Open Manual Fresh Air Damper	240/243 – 300/303

MOTORIZED OUTDOOR AIR DAMPERS		
Model Number	Description	Use With Model Size
CRTWOPOS012A00	Motorized 2 position outdoor air damper	181/183 – 210/213
CRTWOPOS013A00	Motorized 2 position outdoor air damper	240/243 – 300/303

LOW AMBIENT CONTROLS		
Model Number	Description	Use With Model Size
CRLOWAMB041A00	Motormaster I –20° Low Ambient Control 208/230–3–60	181/183–210/213–240/243–300/303
CRLOWAMB042A00	Motormaster I –20° Low Ambient Control 460–3–60, 575–3–60	181/183–210/213–240/243–300/303
CRTRXKIT001A00	Motormaster I –20° Transformer 575–3–60 <sup>1</sup>	181/183–210/213–240/243–300/303

CONTROL UPGRADE KITS		
Model Number	Description	Use With Model Size
NRTIMEGD001A00	Time Guard II	181 – 303
CRSDTEST001A00	Smoke detector remote Test/Reset/Alarm indicator kit	181 – 303
CRPHASE3001A02	Electronic Phase Monitor – All 208/230/460–3–60 models	181 – 303
CRPHASE3002A00	Electronic Phase Monitor – All 575–3–60 models	181 – 303
CRSTATUS005A00	Fan/filter Status Switch – Indicator light not included	181 – 303
CRSMKSEN002A00	Smoke Detector Control Module	181 – 303
CRSMKKIT002A00	Smoke Detector Control Module (Smoke Detector Sensor with sampling tube & exhaust tube)	181 – 303
DNWINSTR001A00	Winter Start Kit – Contains time delay relay for timed bypass of low pressure switch on startup	181 – 303

\* When power exhaust is used on horizontal applications, it must be field mounted to the side of the return duct.

<sup>1</sup> Must use in conjunction with CRLOWAMB042A00 if used on 575–3–60 models.

## ACCESSORIES – RGH181–303 (cont.)

<b>PROPANE GAS CONVERSION KITS</b>		
<b>Model Number</b>	<b>Description</b>	<b>Use With Model Size</b>
CRLPKIT9001A00	Propane Conversion kit. for use between 0' to 2,000'	181 – 303
CRLPELEV005A00	Propane and Hi Altitude conversion kit. for use between 2001' to 10,000'	181 – 303
CRLPELEV006A00	Propane and Hi Altitude conversion kit. for use between 10,001' to 14,000/	181 – 303
<b>NATURAL GAS HIGH ALTITUDE CONVERSION KITS</b>		
<b>Model Number</b>	<b>Description</b>	<b>Use With Model Size</b>
CRNGELEV001A00	High Altitude Conversion kit. for use between 3,000' to 10,000'	181 – 303
CRNGELEV002A00	High Altitude Conversion kit. for use between 10,001' to 14,000'	181 – 303
<b>HEATING UPGRADE KITS</b>		
<b>Model Number</b>	<b>Description</b>	<b>Use With Model Size</b>
CRFLUEDS006A00	Flue Discharge Deflector	181 – 303
<b>4" FILTER TRACK UPGRADE KIT</b>		
<b>Model Number</b>	<b>Description</b>	<b>Use With Model Size</b>
CRFLTTRK001A00	4" Field Conversion Kit	181 – 303
<b>LOUVERED HAIL GUARDS</b>		
<b>Model Number</b>	<b>Description</b>	<b>Use With Model Size</b>
CRLVHLGD017A00	Louvered Condenser Coil Hail Guard	181/183
CRLVHLGD030A00	Louvered Condenser Coil Hail Guard	210/213
CRLVHLGD031A00	Louvered Condenser Coil Hail Guard	240/243
CRLVHLGD029A00	Louvered Condenser Coil Hail Guard	300/303

**Table 2 – AHRI COOLING RATING TABLE**

MODEL RGH	COOLING STAGES	NOMINAL CAPACITY (TONS)	NET COOLING CAPACITY (MBH)	TOTAL POWER (kW)	EER	IEER
181 – 183	2	15	174.0	14.3	12.0	13.0
210 – 213	2	17.5	202.0	16.8	12.0	13.0
240 – 243	2	20	236.0	19.7	12.0	13.2
300 – 303	2	25	282.0	25.2	11.2	12.0

**LEGEND**

- AHRI – Air-Conditioning & Refrigeration Institute
- ASHRAE – American Society of Heating, Refrigerating and Air Conditioning, Inc.
- IEER – Integrated Energy Efficiency Ratio
- IPLV – Integrated Part Load Value

**NOTES:**

1. Rated and certified under AHRI Standard 340/360-04, as appropriate.
2. Ratings are based on:  
**Cooling Standard:** 80°F (27°C) db, 67°F (19°C) wb indoor air temp and 95°F (35°C) db outdoor air temp.  
**IEER Standard:** A measure that expresses cooling part-load EER efficiency for commercial unitary air conditioning and heat pump equipment on the basis of weighted operation at various load capacities.
3. All RGH units comply with ASHRAE 90.1 2001, 2004 Energy Standard for minimum SEER and EER requirements.
4. RGH units comply with US Energy Policy Act (2005). To evaluate code compliance requirements, refer to state and local codes or visit the following website: <http://bcap-energy.org> to determine if compliance with this standard pertains to your state, territory, or municipality.



As an Energy Star® Partner, International Comfort Products has determined that this product meets the ENERGY STAR® guidelines for energy efficiency.



Use of the AHRI Certified TM Mark indicates a manufacturer's participation in the program. For verification of certification for individual products, go to [www.ahridirectory.org](http://www.ahridirectory.org).





**Table 3 – HEATING RATING TABLE – NATURAL GAS & PROPANE**

MODEL RGH	HEAT SIZE	AL/SS HEAT EXCHANGER		TEMP RISE (DEG F)	THERMAL EFFICIENCY (%)
		INPUT / OUTPUT STAGE 1 (MBH)	INPUT / OUTPUT STAGE 2 (MBH)		
181 – 183	LOW	176 / 142	220 / 178	20 – 55	81%
	MED	248 / 200	310 / 251	30 – 60	81%
	HIGH	320 / 260	400 / 324	35 – 65	81%
210 – 213	LOW	176 / 142	220 / 178	15 – 55	81%
	MED	248 / 200	310 / 251	25 – 60	81%
	HIGH	320 / 260	400 / 324	30 – 65	81%
240 – 243	LOW	176 / 142	220 / 178	15 – 55	81%
	MED	248 / 200	310 / 251	20 – 60	81%
	HIGH	320 / 260	400 / 324	30 – 65	81%
300 – 303	LOW	176 / 142	220 / 178	10 – 55	81%
	MED	248 / 200	310 / 251	15 – 60	81%
	HIGH	320 / 260	400 / 324	20 – 65	81%

**NOTE:**

Heat ratings are for natural gas heat exchangers operated at or below 2000 ft. For information on Propane or altitudes above 2000 ft (610m), see the Application Data section of this book. Accessory Propane/High Altitude kits are also available.

In the USA the input rating for altitudes above 2000 ft (610m) must be derated by 4% for each 1000 ft (305 m) above sea level. In Canada, the input rating must be derated by 10% for altitudes of 2000 ft (610 m) to 4500 ft (1372 m) above sea level.

**Table 4 – SOUND PERFORMANCE TABLE**

MODEL RGH	COOLING STAGES	Outdoor Sound (dB)									
		A-Wtg.	ARI 370 Rating	63	125	250	500	1000	2000	4000	8000
181 – 183	2	84.1	84	92.2	83.9	80.4	81.8	78.7	76.5	72.2	65.4
210 – 213	2	84.1	84	92.2	83.9	80.4	81.8	78.7	76.5	72.2	65.4
240 – 243	2	86.5	87	95.6	87.5	84.2	84.2	81.7	77.9	73.2	66.3
300 – 303	2	85.9	86	97.1	88.3	84.4	83.3	80.7	77.4	73.4	67.3

**LEGEND**

dB – Decibel

**NOTES:**

1. Outdoor sound data is measured in accordance with AHRI standard 270–2008.
2. Measurements are expressed in terms of sound power. Do not compare these values to sound pressure values because sound pressure depends on specific environmental factors which normally do not match individual applications. Sound power values are independent of the environment and therefore more accurate.
3. A-weighted sound ratings filter out very high and very low frequencies, to better approximate the response of “average” human ear. A-weighted measurements are taken in accordance with AHRI standard 270–2008.



Use of the AHRI Certified TM Mark indicates a manufacturer's participation in the program. For verification of certification for individual products, go to



**Table 5 – MINIMUM – MAXIMUM AIRFLOW RATINGS – NATURAL GAS & LIQUID PROPANE**

MODEL RGH	HEAT SIZE	COOLING		AL HX HEATING		SS HX HEATING	
		MINIMUM	MAXIMUM	MINIMUM	MAXIMUM	MINIMUM	MAXIMUM
181 – 183	LOW			3000	8250	3000	8250
	MED	4500	7500	3880	7750	3880	7750
	HIGH			4620	8570	4620	8570
210 – 213	LOW			3000	11000	2960	11000
	MED	5250	9000	3880	9300	3880	9300
	HIGH			4620	10000	4620	10000
240 – 243	LOW			3000	11000	3000	11000
	MED	6000	10000	3880	11630	3880	11630
	HIGH			4620	10000	4620	10000
300 – 303	LOW			3000	16500	2960	16500
	MED	7500	12500	3880	15500	3880	15500
	HIGH			4620	15000	4620	15000

**Table 6 – PHYSICAL DATA (COOLING) 15 – 25 TONS**

RGH	181 – 183	210 – 213	240 – 243	300 – 303	
<b>Refrigeration System</b>					
# Circuits / # Comp. / Type	2 / 2 / Scroll	2 / 2 / Scroll	2 / 2 / Scroll	2 / 2 / Scroll	
R-410a charge A/B (lbs)	17/16.4	17.5/16.8	23.8/23.1	24.9/27.7	
Metering device	TXV	TXV	TXV	TXV	
High-press. Trip / Reset (psig)	630 / 505	630 / 505	630 / 505	630 / 505	
Low-press. Trip / Reset (psig)	54 / 117	54 / 117	54 / 117	54 / 117	
Compressor Capacity Staging (%)	50% / 100%	50% / 100%	50% / 100%	50% / 100%	
<b>Evap. Coil</b>					
Material	Cu / Al	Cu / Al	Cu / Al	Cu / Al	
Tube Diameter	3/8" RTPF	3/8" RTPF	3/8" RTPF	3/8" RTPF	
Rows / FPI	4 / 15	4 / 15	4 / 15	4 / 15	
Total face area (ft2)	22	22	26	26	
Condensate drain conn. size	3/4"	3/4"	3/4"	3/4"	
<b>Evap. fan and motor</b>					
<b>VERTICAL</b>					
Standard Static	Motor Qty / Drive type	1 / Belt	1 / Belt	1 / Belt	1 / Belt
	Max BHP	2.2	3.3	4.9	4.9
	RPM range	514-680	622-822	690-863	717-911
	Motor frame size	56	56	56	56
	Fan Qty / Type	2 / Centrifugal	2 / Centrifugal	2 / Centrifugal	2 / Centrifugal
	Fan Diameter (in)	15 x 15	15 x 15	15 x 15	15 x 15
Medium Static	Motor Qty / Drive type	1 / Belt	1 / Belt	1 / Belt	1 / Belt
	Max BHP	3.3	4.9	6.5	6.5
	RPM range	679-863	713-879	835-1021	913-1116
	Motor frame size	56	56	184T	184T
	Fan Qty / Type	2 / Centrifugal	2 / Centrifugal	2 / Centrifugal	2 / Centrifugal
	Fan Diameter (in)	15 x 15	15 x 15	15 x 15	15 x 15
High Static	Motor Qty / Drive type	1 / Belt	1 / Belt	1 / Belt	1 / Belt
	Max BHP	4.9	6.5	8.7	8.7
	RPM range	826-1009	882-1078	941-1176	941-1176
	Motor frame size	56	184T	213T	213T
	Fan Qty / Type	2 / Centrifugal	2 / Centrifugal	2 / Centrifugal	2 / Centrifugal
	Fan Diameter (in)	15 x 15	15 x 15	15 x 15	15 x 15
Medium Static High Eff*	Motor Qty / Drive type	n/a	n/a	1 / Belt	1 / Belt
	Max BHP	n/a	n/a	6.5	6.5
	RPM range	n/a	n/a	835-1021	913-1116
	Motor frame size	n/a	n/a	184T	184T
	Fan Qty / Type	n/a	n/a	2 / Centrifugal	2 / Centrifugal
	Fan Diameter (in)	n/a	n/a	15 x 15	15 x 15
High Static High Eff*	Motor Qty / Drive type	n/a	1 / Belt	1 / Belt	1 / Belt
	Max BHP	n/a	6.5	8.7	8.7
	RPM range	n/a	882-1078	941-1176	941-1176
	Motor frame size	n/a	184T	213T	213T
	Fan Qty / Type	n/a	2 / Centrifugal	2 / Centrifugal	2 / Centrifugal
	Fan Diameter (in)	n/a	15 x 15	15 x 15	15 x 15

\* Section 313 of the Energy Independence and Security Act of 2007 (EISA 2007) mandates that the efficiency of general purpose motors used in Light Commercial Rooftops rated at 5.0 HP and larger be increased on or after December 19, 2010. High and standard efficiency motors will be offered until inventory is depleted, at which time only high efficiency motors will be available.

**TABLE 6 – PHYSICAL DATA (COOLING) 15 – 25 TONS (CONT.)**

RGH		181 – 183	210 – 213	240 – 243	300 – 303
<b>HORIZONTAL</b>					
Standard Static	Motor Qty / Drive type	1 / Belt	1 / Belt	1 / Belt	1 / Belt
	Max BHP	2.2	3.3	4.9	4.9
	RPM range	514–680	622–822	690–863	647–791
	Motor frame size	56	56	56	184T
	Fan Qty / Type	2 / Centrifugal	2 / Centrifugal	2 / Centrifugal	2 / Centrifugal
	Fan Diameter (in)	18 x 15/15 X 11	18 x 15/15 X 11	18 x 15/15 X 11	18 x 15/15 X 11
Medium Static	Motor Qty / Drive type	1 / Belt	1 / Belt	1 / Belt	1 / Belt
	Max BHP	3.3	4.9	6.5	6.5
	RPM range	614–780	713–879	835–1021	755–923
	Motor frame size	56	56	184T	184T
	Fan Qty / Type	2 / Centrifugal	2 / Centrifugal	2 / Centrifugal	2 / Centrifugal
	Fan Diameter (in)	18 x 15/15 X 11	18 x 15/15 X 11	18 x 15/15 X 11	18 x 15/15 X 11
High Static	Motor Qty / Drive type	1 / Belt	1 / Belt	1 / Belt	1 / Belt
	Max BHP	4.9	6.5	8.7	8.7
	RPM range	746–912	882–1078	941–1176	827–1010
	Motor frame size	56	184T	213T	213T
	Fan Qty / Type	2 / Centrifugal	2 / Centrifugal	2 / Centrifugal	2 / Centrifugal
	Fan Diameter (in)	18 x 15/15 X 11	18 x 15/15 X 11	18 x 15/15 X 11	18 x 15/15 X 11
Medium Static High Eff*	Motor Qty / Drive type	n/a	n/a	1 / Belt	1 / Belt
	Max BHP	n/a	n/a	6.5	6.5
	RPM range	n/a	n/a	835–1021	755–923
	Motor frame size	n/a	n/a	184T	184T
	Fan Qty / Type	n/a	n/a	2 / Centrifugal	2 / Centrifugal
	Fan Diameter (in)	n/a	n/a	18 x 15/15 x 11	18 x 15/15 x 11
High Static High Eff*	Motor Qty / Drive type	n/a	1 / Belt	1 / Belt	1 / Belt
	Max BHP	n/a	6.5	8.7	8.7
	RPM range	n/a	882–1078	941–1176	827–1010
	Motor frame size	n/a	184T	213T	213T
	Fan Qty / Type	n/a	2 / Centrifugal	2 / Centrifugal	2 / Centrifugal
	Fan Diameter (in)	n/a	18 x 15/15 x 11	18 x 15/15 x 11	18 x 15/15 x 11
<b>Cond. Coil (Circuit A)</b>					
	Coil type	RTPF	RTPF	RTPF	RTPF
	Coil Length (in)	70	72	82	95
	Coil Height (in)	44	44	52	52
	Rows / FPI (fins per inch)	2 / 17	2 / 17	2 / 17	2 / 17
	Total face area (ft2)	21.4	22.0	29.6	34.3
<b>Cond. Coil (Circuit B)</b>					
	Coil type	RTPF	RTPF	RTPF	RTPF
	Coil Length (in)	70	64	80	95
	Coil Height (in)	44	44	52	52
	Rows / FPI (fins per inch)	2 / 17	2 / 17	2 / 17	2 / 17
	Total face area (ft2)	21.4	19.5	29.6	34.3
<b>Cond. fan / motor</b>					
	Qty / Motor drive type	3 / direct	4 / direct	4 / direct	6 / direct
	Motor HP / RPM	1/4 / 1100	1/4 / 1100	1/4 / 1100	1/4 / 1100
	Fan diameter (in)	22	22	22	22
<b>Filters</b>					
	RA Filter # / size (in)	6 / 20 x 25 x 2	6 / 20 x 25 x 2	9 / 16 x 25 x 2	9 / 16 x 25 x 2
	OA inlet screen # / size (in)	4 / 16 x 25 x 1	4 / 16 x 25 x 1	4 / 16 x 25 x 1	4 / 16 x 25 x 1



\* Section 313 of the Energy Independence and Security Act of 2007 (EISA 2007) mandates that the efficiency of general purpose motors used in Light Commercial Rooftops rated at 5.0 HP and larger be increased on or after December 19, 2010. High and standard efficiency motors will be offered until inventory is depleted, at which time only high efficiency motors will be available.

**Table 7 – PHYSICAL DATA (HEATING) 15 – 25 TONS**

RGH		181 – 183	210 – 213	240 – 243	300 – 303
<b>Gas Connection</b>					
	# of Gas Valves	1	1	1	1
	Nat. gas supply line press (in. w.g.)/(PSIG)	5 – 13 / 0.18–0.47	5 – 13 / 0.18–0.47	5 – 13 / 0.18–0.47	5 – 13 / 0.18–0.47
	Propane supply line press (in. w.g.)/(PSIG)	11–13 / 0.40–0.47	11–13 / 0.40–0.47	11–13 / 0.40–0.47	11–13 / 0.40–0.47
<b>Heat Anticipator Setting (Amps)</b>					
	1st stage	0.14	0.14	0.14	0.14
	2nd stage	0.14	0.14	0.14	0.14
<b>Natural Gas Heat</b>					
LOW	# of stages / # of burners (total)	2 / 5	2 / 5	2 / 5	2 / 5
	Connection size	3/4" NPT	3/4" NPT	3/4" NPT	3/4" NPT
	Rollout switch opens / closes	195 / 115	195 / 115	195 / 115	195 / 115
	Temperature rise range (F)	25 – 55	25 – 55	25 – 55	25 – 55
MED	# of stages / # of burners (total)	2 / 7	2 / 7	2 / 7	2 / 7
	Connection size	3/4" NPT	3/4" NPT	3/4" NPT	3/4" NPT
	Rollout switch opens / closes	195 / 115	195 / 115	195 / 115	195 / 115
	Temperature rise range (F)	30– 60	30– 60	30– 60	30– 60
HIGH	Connection size	2 / 10	2 / 10	2 / 10	2 / 10
	# of stages / # of burners (total)	3/4" NPT	3/4" NPT	3/4" NPT	3/4" NPT
	Rollout switch opens / closes	195 / 115	195 / 115	195 / 115	195 / 115
	Temperature rise range (F)	35– 65	35– 65	35– 65	35– 65
<b>Liquid Propane Heat</b>					
LOW	# of stages / # of burners (total)	2 / 5	2 / 5	2 / 5	2 / 5
	Connection size	3/4" NPT	3/4" NPT	3/4" NPT	3/4" NPT
	Rollout switch opens / closes	195 / 115	195 / 115	195 / 115	195 / 115
	Temperature rise range (F)	25 – 55	25 – 55	25 – 55	25 – 55
MED	# of stages / # of burners (total)	2 / 7	2 / 7	2 / 7	2 / 7
	Connection size	3/4" NPT	3/4" NPT	3/4" NPT	3/4" NPT
	Rollout switch opens / closes	195 / 115	196 / 115	197 / 115	198 / 115
	Temperature rise range (F)	30– 60	30– 60	30– 60	30– 60
HIGH	# of stages / # of burners (total)	2 / 10	2 / 10	2 / 10	2 / 10
	Connection size	3/4" NPT	3/4" NPT	3/4" NPT	3/4" NPT
	Rollout switch opens / closes	195 / 115	195 / 115	195 / 115	195 / 115
	Temperature rise range (F)	35– 65	35– 65	35– 65	35– 65

# BASE UNIT DIMENSIONS - RGH181/183

**NOTES:**

1. DIMENSIONS ARE IN INCHES, DIMENSIONS IN [ ] ARE IN MILLIMETERS.
2.  CENTER OF GRAVITY
3.  DIRECTION OF AIR FLOW

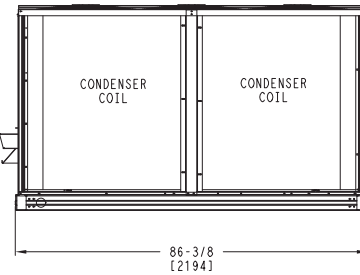
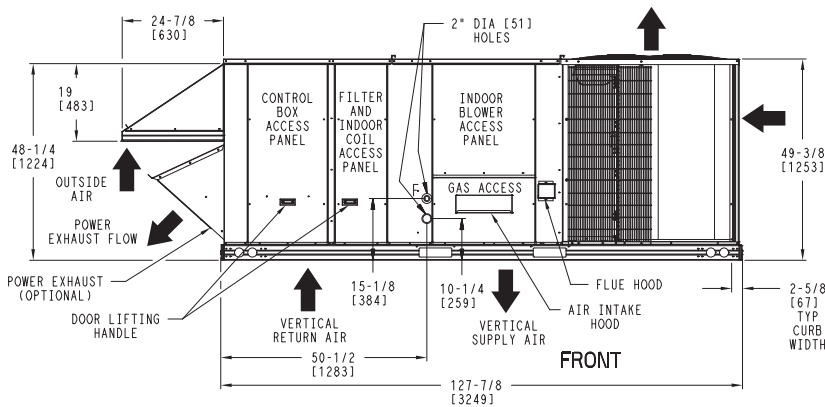
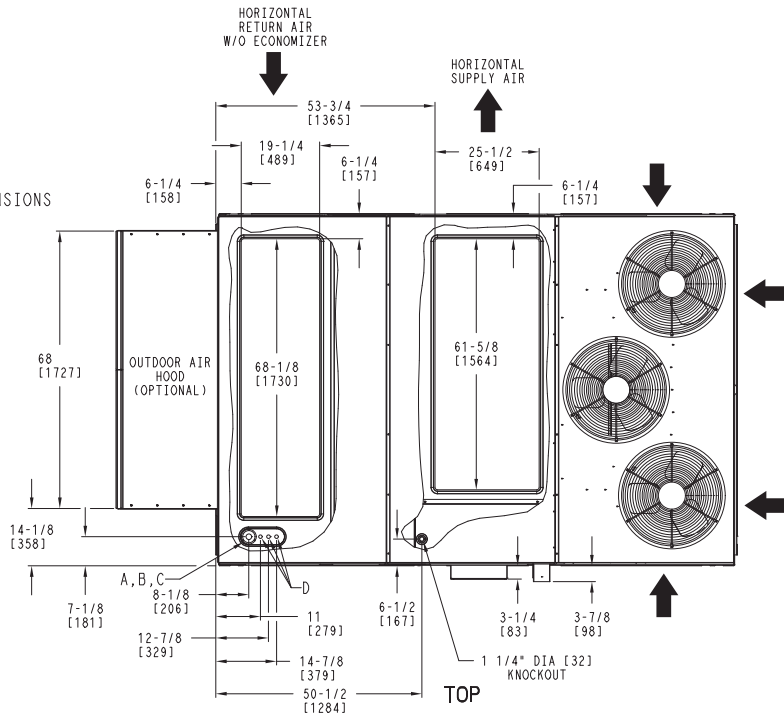

RIGHT

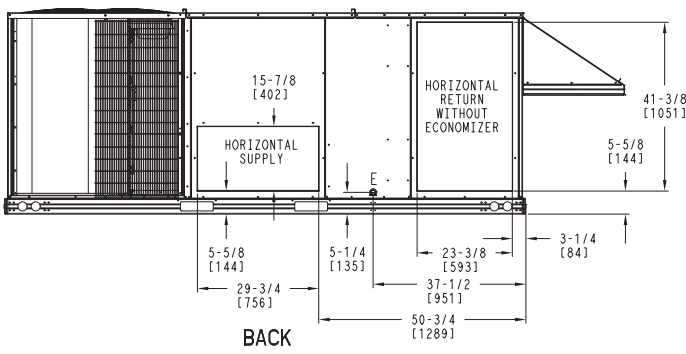

(HORIZONTAL DISCHARGE W/O ECON)  
(WHEN ORDERED)

CONNECTION SIZES	
A	1 3/8" DIA [35] FIELD POWER SUPPLY KNOCKOUT
B	3" DIA [76] FIELD POWER SUPPLY KNOCKOUT
C	3 5/8" DIA [92] FIELD POWER SUPPLY KNOCKOUT
D	7/8" DIA [22] FIELD CONTROL WIRING HOLE
E	3/4"-14 NPT CONDENSATE DRAIN
F	3/4"-14 NPT GAS CONNECTION (NOT SHOWN)

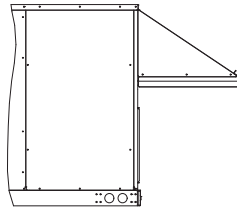

BACK

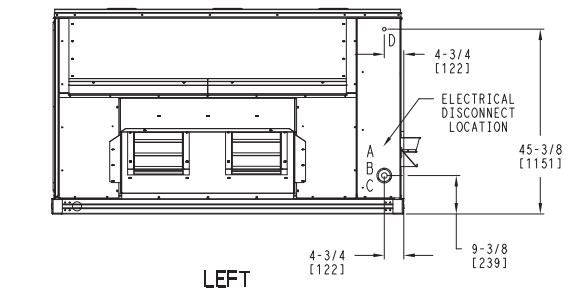

LEFT

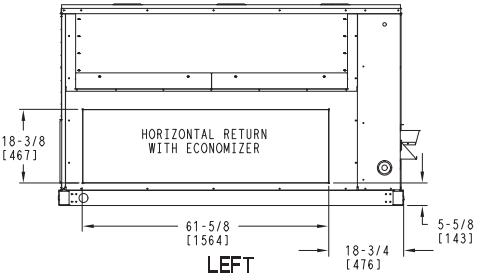

LEFT

(HORIZONTAL DISCHARGE W/ ECON)  
(WHEN ORDERED)

## WEIGHT & DIMENSIONS – RGH181/183 (cont.)

UNIT	STD UNIT WEIGHT *		CORNER WEIGHT (A)		CORNER WEIGHT (B)		CORNER WEIGHT (C)		CORNER WEIGHT (D)		C.G.		
	LBS.	KG.	LBS.	KG.	LBS.	KG.	LBS.	KG.	LBS.	KG.	X	Y	Z
15 Ton	1892	860	401	182	449	204	565	257	505	230	48 [1219]	67 3/8 [1711]	16 1/2 [419]

\* STANDARD UNIT WEIGHT IS WITH LOW GAS HEAT AND WITHOUT PACKAGING.

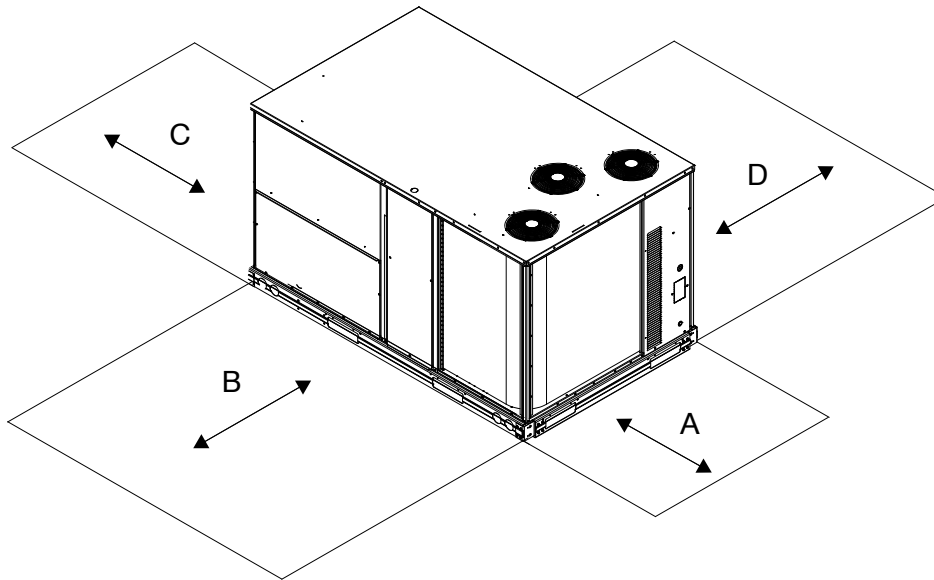
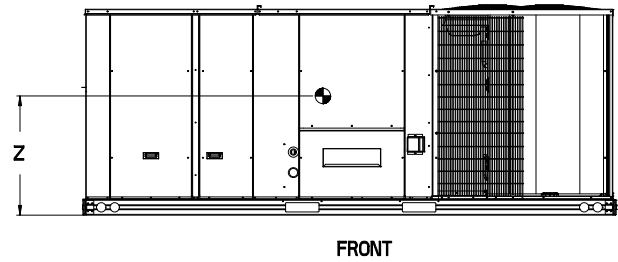
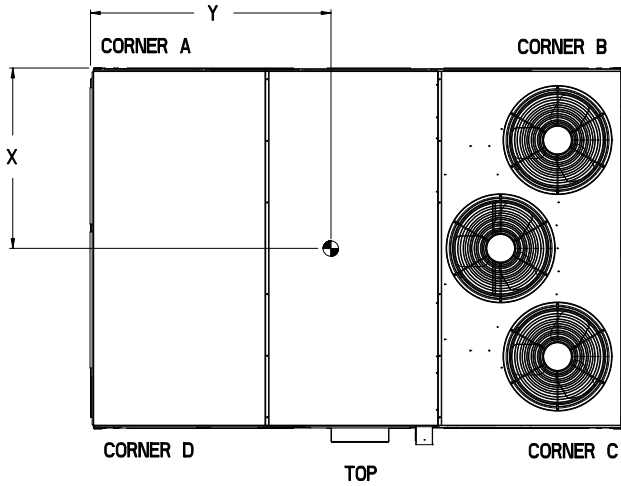

LOC	DIMENSION	CONDITION
A	48-in. (1219 mm)	Unit disconnect is mounted on panel
	18-in. (457 mm)	No disconnect, convenience outlet option
	18-in. (457 mm)	Recommended service clearance
	12-in. (305 mm)	Minimum clearance
B	42-in. (1067 mm)	Surface behind servicer is grounded (e.g., metal, masonry wall)
	36-in. (914 mm)	Surface behind servicer is electrically non-conductive (e.g., wood, fiberglass)
	Special	Check for sources of flue products within 10-ft of unit fresh air intake hood
C	36-in. (914 mm)	Side condensate drain is used
	18-in. (457 mm)	Minimum clearance
D	42-in. (1067 mm)	Surface behind servicer is grounded (e.g., metal, masonry wall, another unit)
	36-in. (914 mm)	Surface behind servicer is electrically non-conductive (e.g., wood, fiberglass)

# ROOF CURB DETAILS – RGH181/183

RoofCurb Accessory	A	Unit Size
CRRFCURB045A00	1' 2" [356]	15 Ton
CRRFCURB046A00	2' 0" [610]	

**NOTES:**

1. Roofcurb accessory is shipped disassembled.
  2. Dimensions in. [ ] in millimeters.
  3. Roofcurb galvanized steel.
  4. Attach ductwork to curb (Flanges of duct rest on curb)
  5. Service clearance 4' on each side.
- ➡ Direction of airflow.

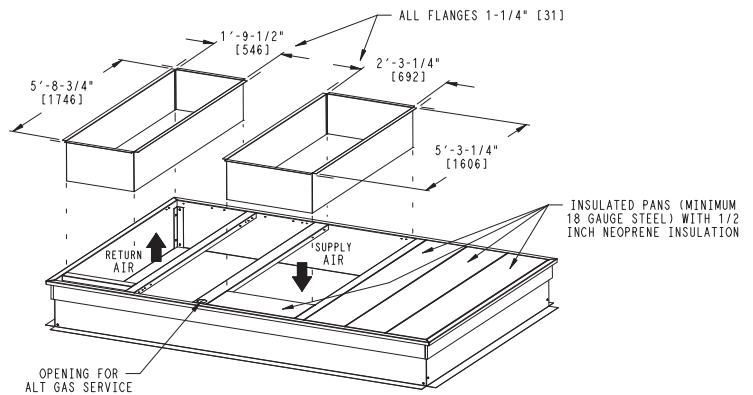
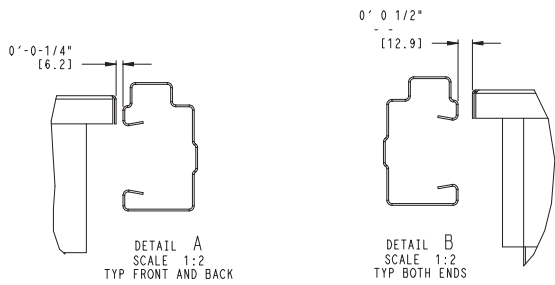
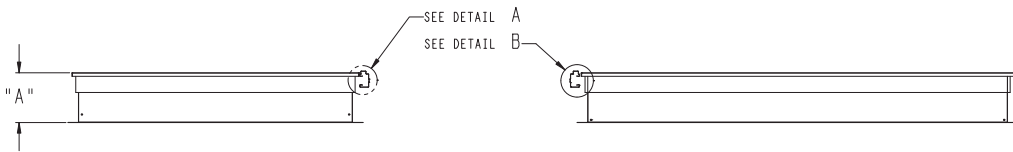
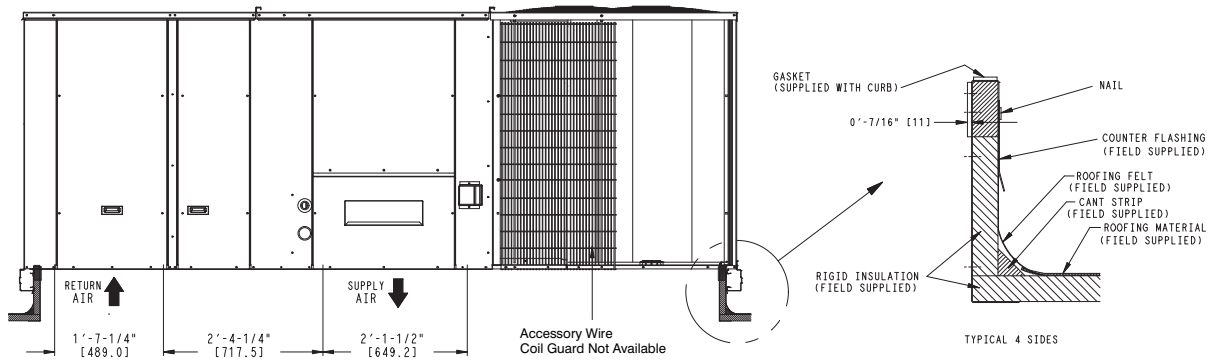
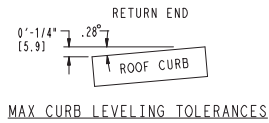
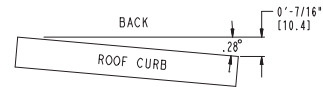
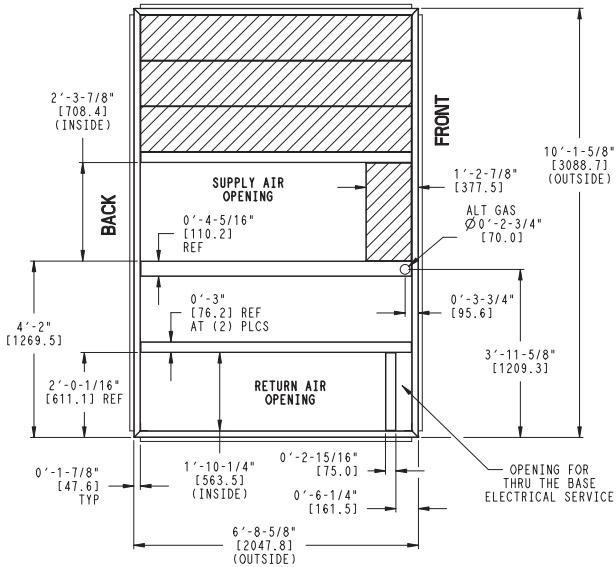

# BASE UNIT DIMENSIONS – RGH210/213 – 240/243

**NOTES:**

1. DIMENSIONS ARE IN INCHES, DIMENSIONS IN [ ] ARE IN MILLIMETERS.
2. CENTER OF GRAVITY
3. DIRECTION OF AIR FLOW

CONNECTION SIZES	
A	1 3/8" DIA [35] FIELD POWER SUPPLY KNOCKOUT
B	3" DIA [76] FIELD POWER SUPPLY KNOCKOUT
C	3 5/8" DIA [92] FIELD POWER SUPPLY KNOCKOUT
D	7/8" DIA [22] FIELD CONTROL WIRING HOLE
E	3/4"-14 NPT CONDENSATE DRAIN
F	3/4"-14 NPT GAS CONNECTION (NOT SHOWN)

UNIT	G	H
17.5Ton	41-3/8 [1051]	49-3/8 [1253]
20Ton	49-3/8 [1253]	57-3/8 [1456]

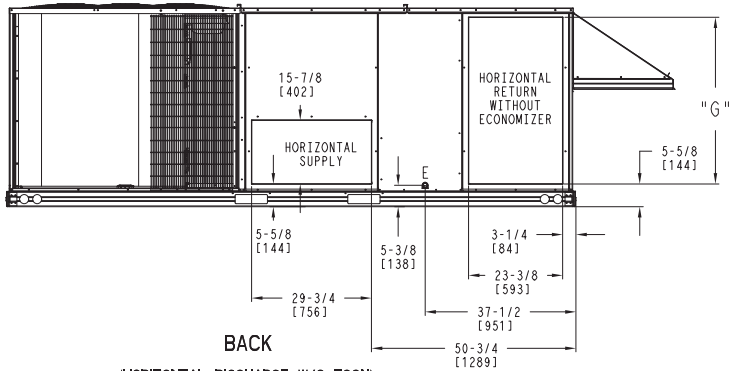
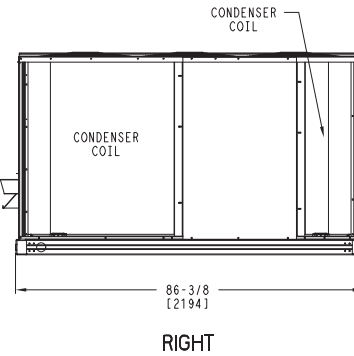
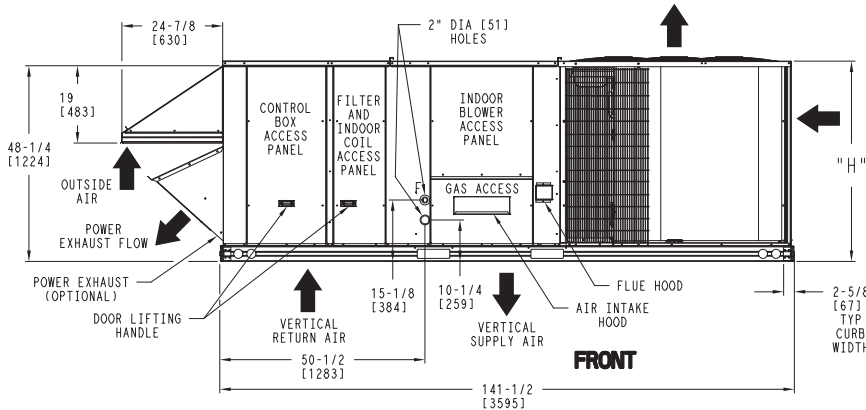
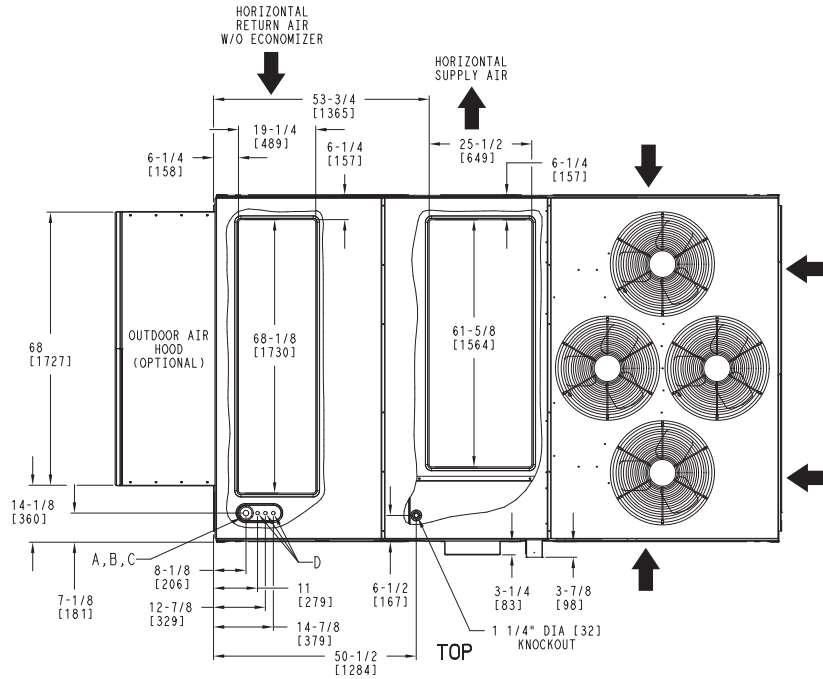

(HORIZONTAL DISCHARGE W/O ECON)  
(WHEN ORDERED)

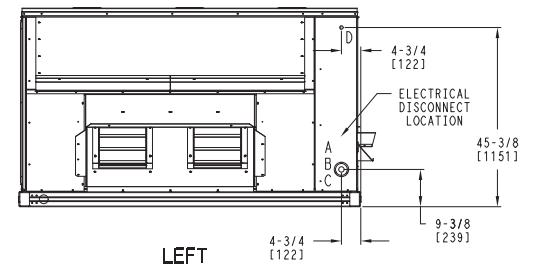

LEFT

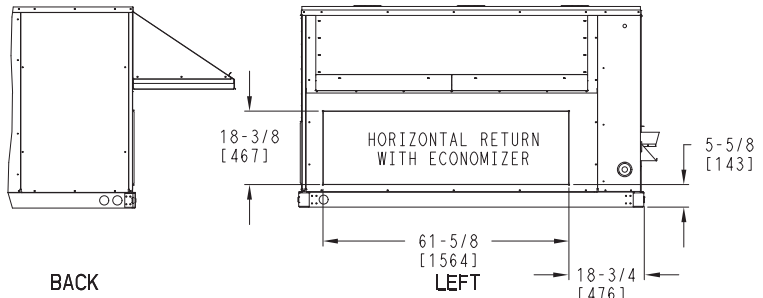

(HORIZONTAL DISCHARGE W/ ECON)  
(WHEN ORDERED)



# WEIGHT & CLEARANCE DIMENSIONS – RGH210/213 – 240/243 (cont.)

UNIT	STD. UNIT WEIGHT *		CORNER WEIGHT (A)		CORNER WEIGHT (B)		CORNER WEIGHT (C)		CORNER WEIGHT (D)		C.G.		
	LBS.	KG.	LBS.	KG.	LBS.	KG.	LBS.	KG.	LBS.	KG.	X	Y	Z
17.5 Ton	2102	956	474	215	390	177	593	269	582	265	47 1/2 [1207]	71 1/4 [1810]	16 1/2 [419]
20Ton	2247	1021	540	246	556	253	598	272	581	264	44 5/8 [1133]	71 5/8 [1819]	19 [483]

\* STANDARD UNIT WEIGHT IS WITH LOW GAS HEAT AND WITHOUT PACKAGING.

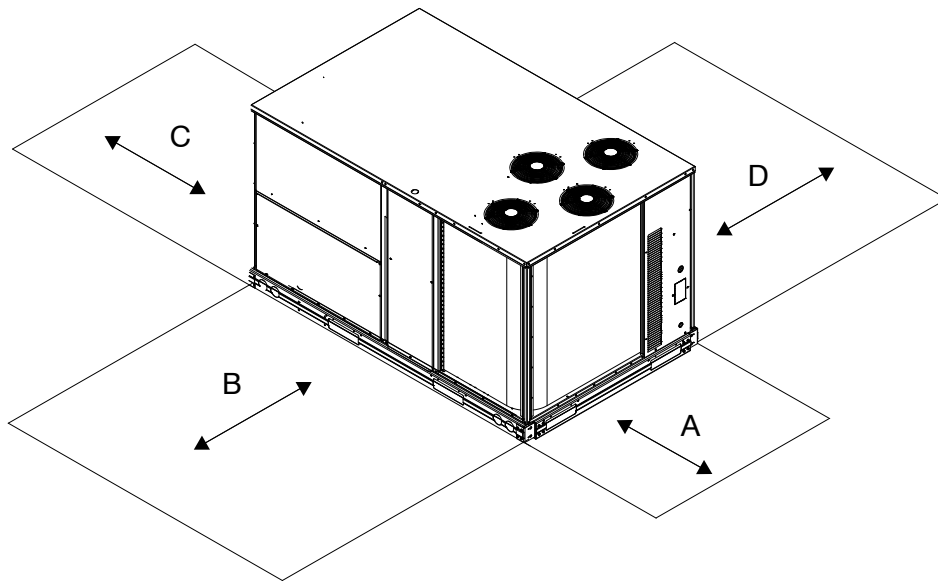
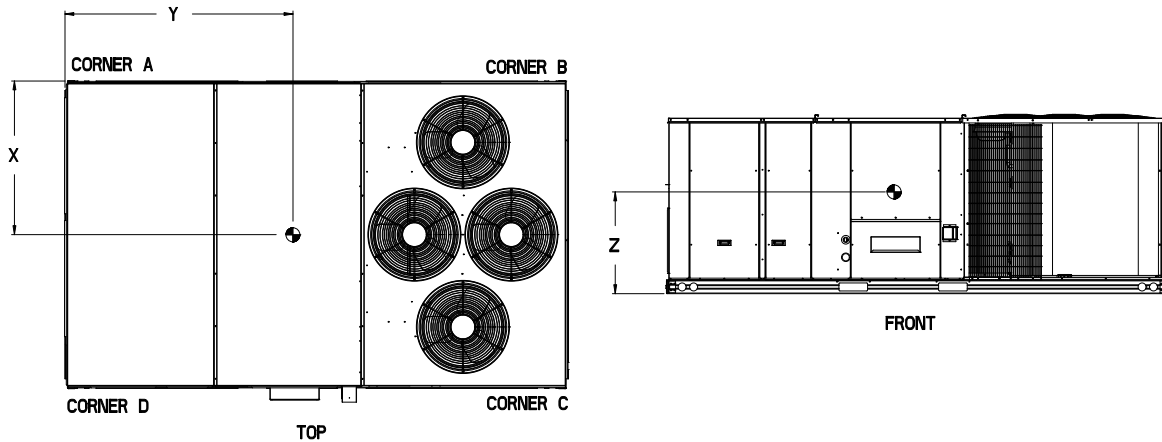

LOC	DIMENSION	CONDITION
A	48-in. (1219 mm)	Unit disconnect is mounted on panel
	18-in. (457 mm)	No disconnect, convenience outlet option
	18-in. (457 mm)	Recommended service clearance
	12-in. (305 mm)	Minimum clearance
B	42-in. (1067 mm)	Surface behind servicer is grounded (e.g., metal, masonry wall)
	36-in. (914 mm)	Surface behind servicer is electrically non-conductive (e.g., wood, fiberglass)
	Special	Check for sources of flue products within 10-ft of unit fresh air intake hood
C	36-in. (914 mm)	Side condensate drain is used
	18-in. (457 mm)	Minimum clearance
D	42-in. (1067 mm)	Surface behind servicer is grounded (e.g., metal, masonry wall, another unit)
	36-in. (914 mm)	Surface behind servicer is electrically non-conductive (e.g., wood, fiberglass)

# ROOF CURB DETAILS – RGH210/213 – 240/243

RoofCurb Accessory	A	Unit Size
CRRFCURB047A00	1' 2" [356]	17.5 ton
CRRFCURB048A00	2' 0" [610]	20 ton

**NOTES:**

1. Roofcurb accessory is shipped disassembled.
  2. Dimensions in. [ ] in millimeters.
  3. Roofcurb galvanized steel.
  4. Attach ductwork to curb (Flanges of duct rest on curb)
  5. Service clearance 4' on each side.
- ➡ Direction of airflow.

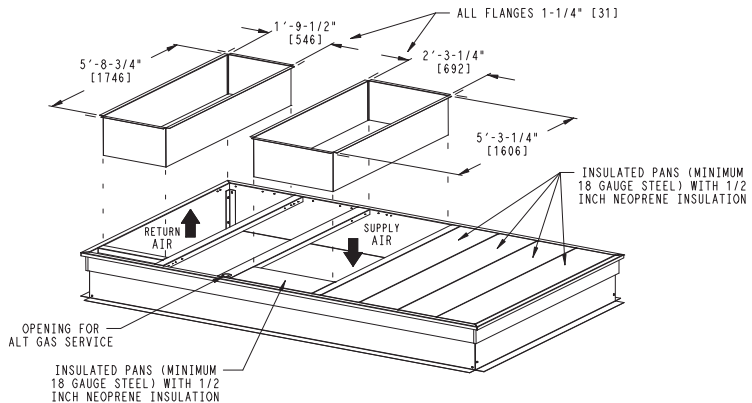
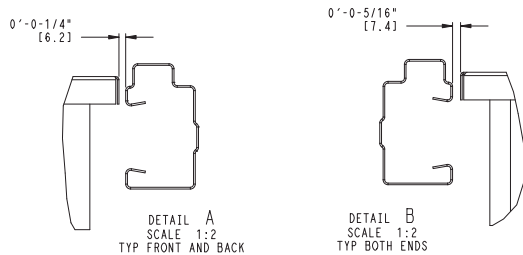
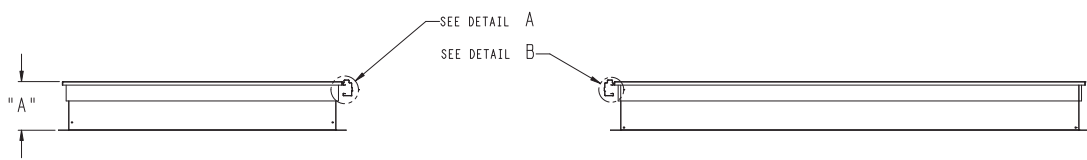
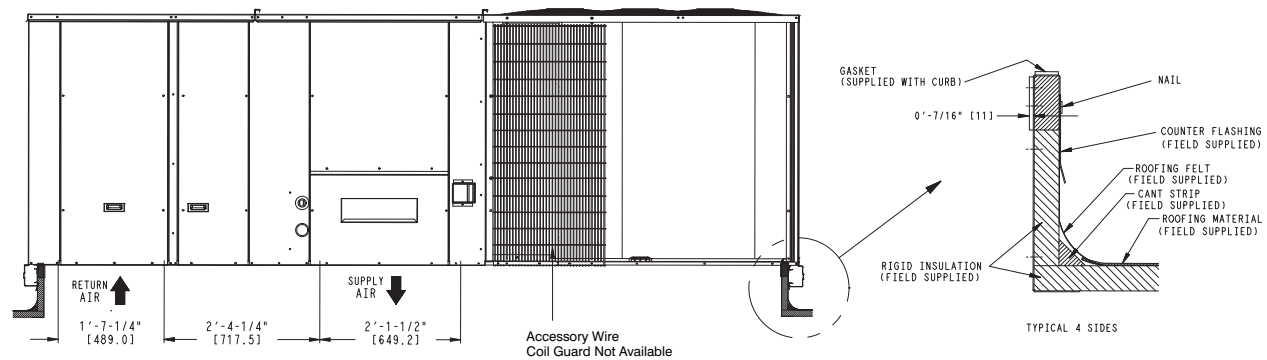
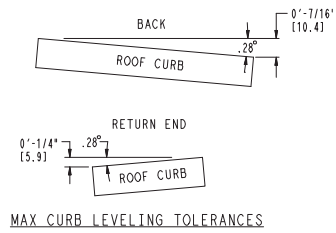
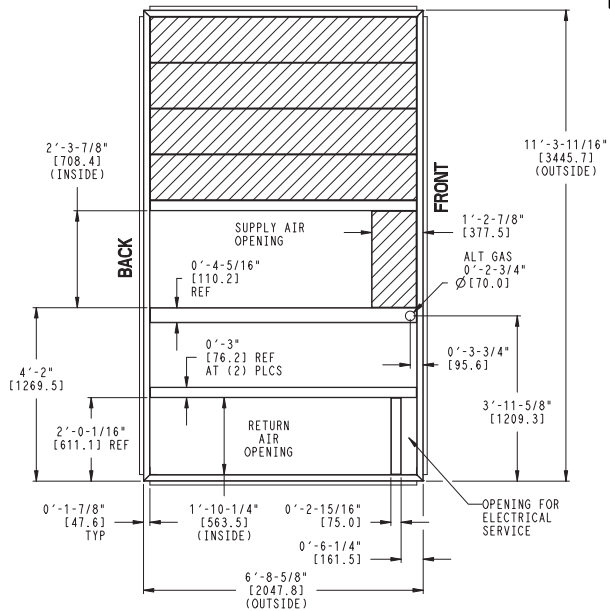

# BASE UNIT DIMENSIONS – RGH300/303

CONNECTION SIZES	
A	1 3/8" DIA [35] FIELD POWER SUPPLY KNOCKOUT
B	3" DIA [76] FIELD POWER SUPPLY KNOCKOUT
C	3 5/8" DIA [92] FIELD POWER SUPPLY KNOCKOUT
D	7/8" DIA [22] FIELD CONTROL WIRING HOLE
E	3/4"-14 NPT CONDENSATE DRAIN
F	3/4"-14 NPT GAS CONNECTION (NOT SHOWN)

- NOTES:
1. DIMENSIONS ARE IN INCHES, DIMENSIONS IN ( ) ARE IN MILLIMETERS.
  2. CENTER OF GRAVITY
  3. DIRECTION OF AIR FLOW

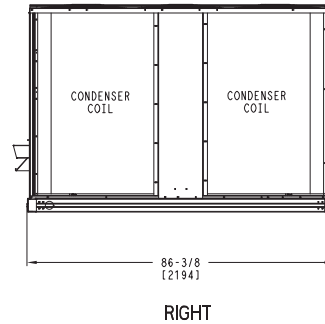
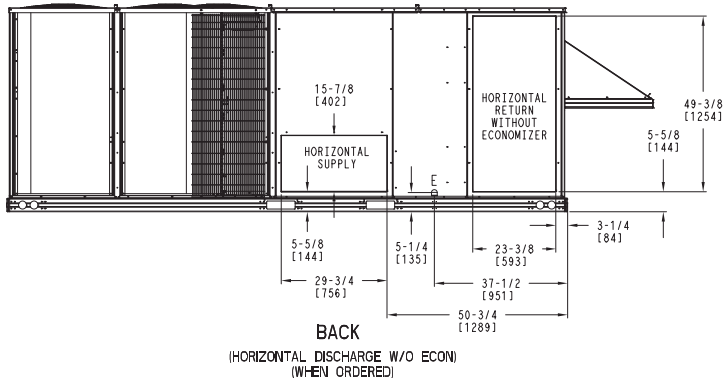
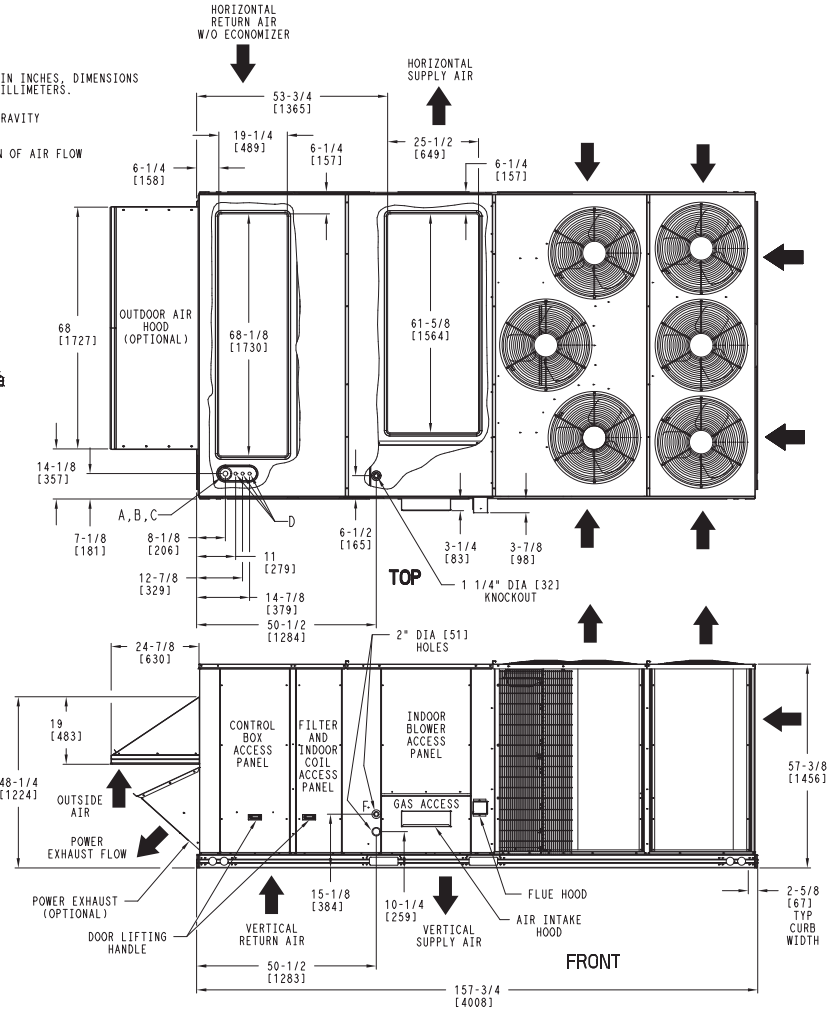
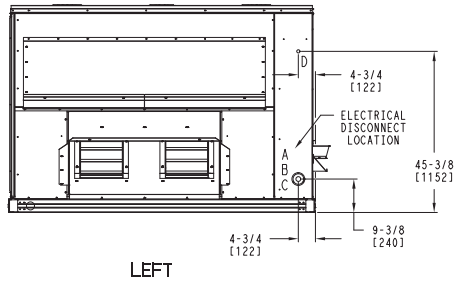
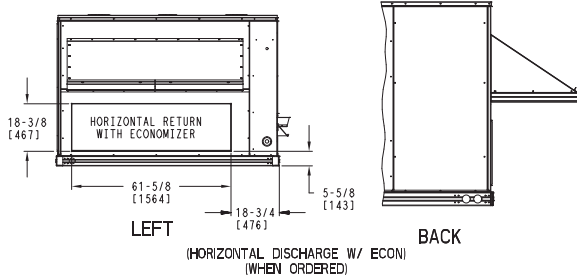

## WEIGHT & CLEARANCE DIMENSIONS – RGH300/303 (cont.)

UNIT	STD UNIT WEIGHT *		CORNER WEIGHT (A)		CORNER WEIGHT (B)		CORNER WEIGHT (C)		CORNER WEIGHT (D)		C.G.		
	LBS.	KG.	LBS.	KG.	LBS.	KG.	LBS.	KG.	LBS.	KG.	X	Y	Z
25 Ton	2193	997	545	248	528	240	551	251	569	259	44 [1118]	77 1/2 [1969]	19 [483]

\* STANDARD UNIT WEIGHT IS WITH LOW GAS HEAT AND WITHOUT PACKAGING.

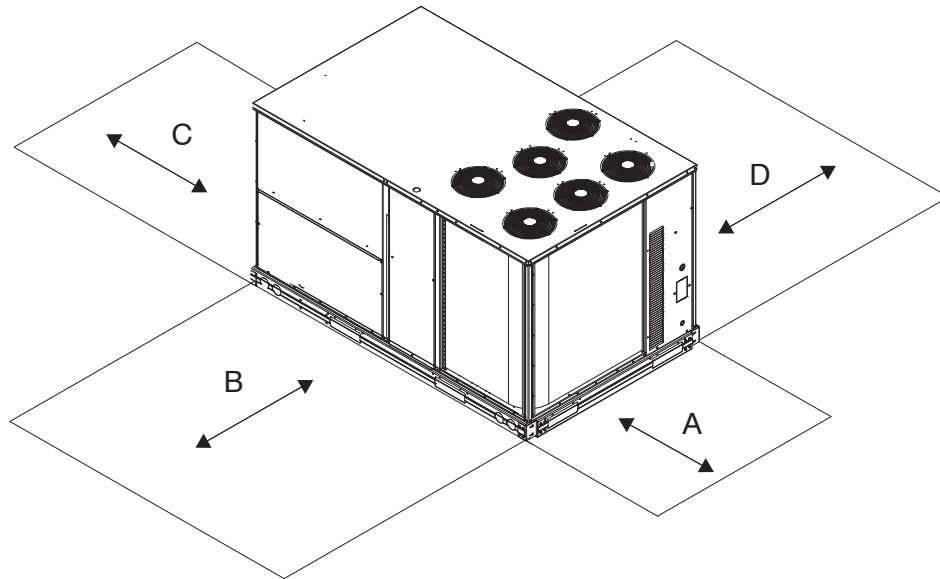
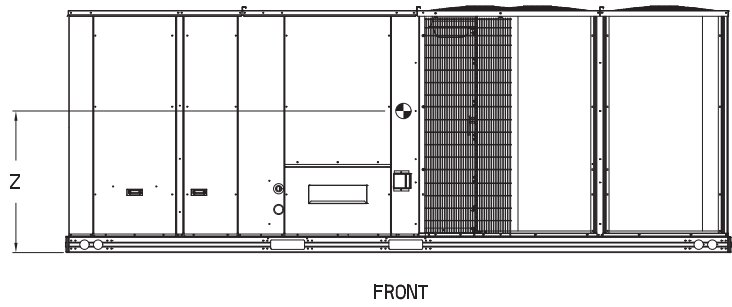
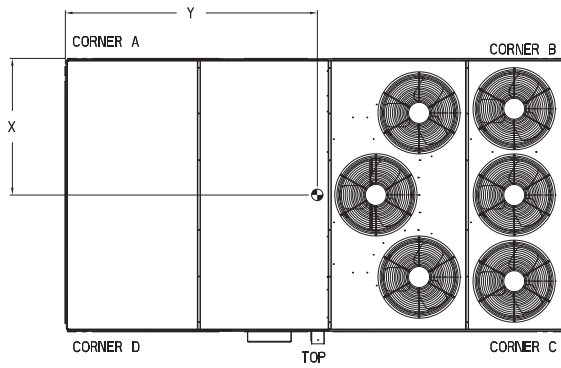

LOC	DIMENSION	CONDITION
A	48-in. (1219 mm)	Unit disconnect is mounted on panel
	18-in. (457 mm)	No disconnect, convenience outlet option
	18-in. (457 mm)	Recommended service clearance
	12-in. (305 mm)	Minimum clearance
B	42-in. (1067 mm)	Surface behind servicer is grounded (e.g., metal, masonry wall)
	36-in. (914 mm) Special	Surface behind servicer is electrically non-conductive (e.g., wood, fiberglass) Check for sources of flue products within 10-ft of unit fresh air intake hood
C	36-in. (914 mm)	Side condensate drain is used
	18-in. (457 mm)	Minimum clearance
D	42-in. (1067 mm)	Surface behind servicer is grounded (e.g., metal, masonry wall, another unit)
	36-in. (914 mm)	Surface behind servicer is electrically non-conductive (e.g., wood, fiberglass)

# ROOF CURB DETAILS – RGH300/303

RoofCurb Accessory	A	Unit Size
CRRFCURB049A00	1' 2" [356]	25 ton
CRRFCURB050A00	2' 0" [610]	

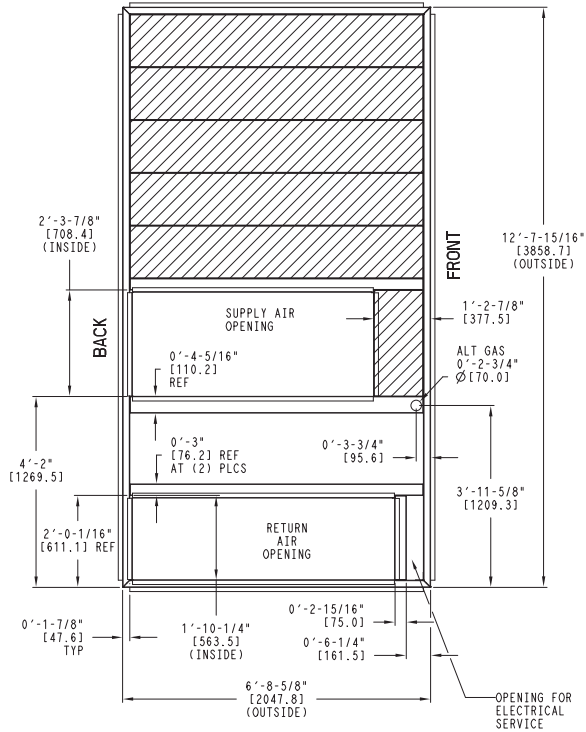

- NOTES:
- 1 ROOF CURB ACCESSORY IS SHIPPED UNASSEMBLED.
  - 2 BOLT HEADS TO BE ON INSIDE OF FLANGE. CLEARANCE IS [11] 0-0-7/16" TYP ALL CORNERS.
  - 3 DIMENSIONS IN [ ] ARE IN MILLIMETERS.
  - 4 ROOF CURB GALVANIZED STEEL.
  - 5 ATTACH DUCTWORK TO CURB (FLANGES ON DUCT REST ON CURB)
  - 6 SERVICE CLEARANCE 4 ft ON EACH SIDE
  - 7 GAS SERVICE PLATE IS PART OF A SEPERATELY SHIPPED ACCESSORY PACKAGE.
  - 8 GAS SERVICE PLATE CAN BE USED WITH EITHER ACCESSORY ROOFCURB.

➔ DIRECTION OF AIR FLOW

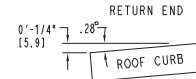
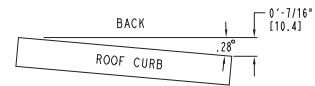

MAX CURB LEVELING TOLERANCES

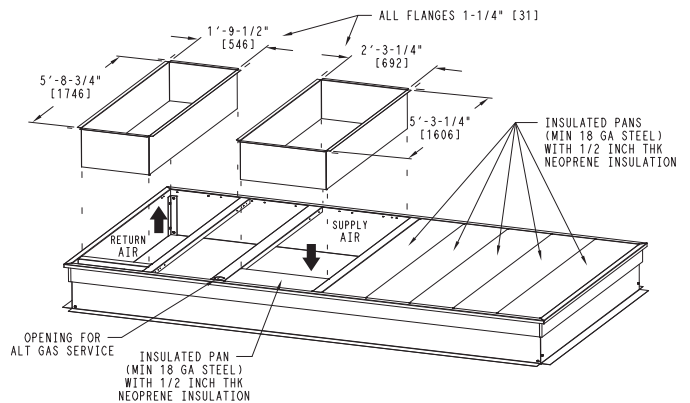
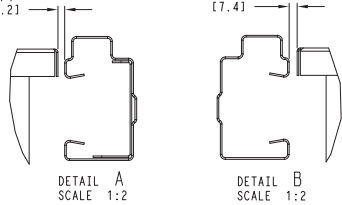
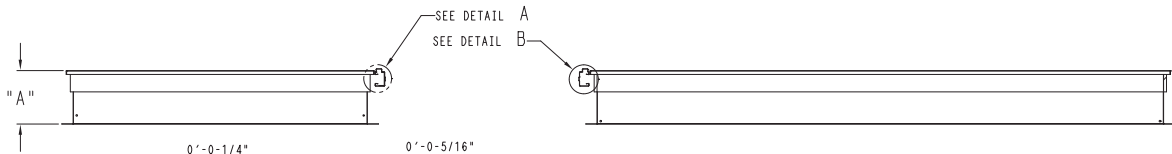
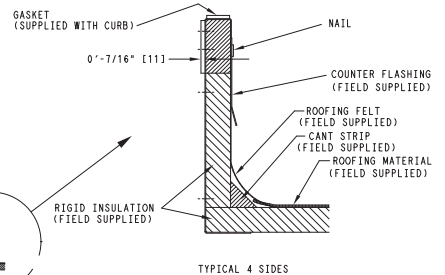
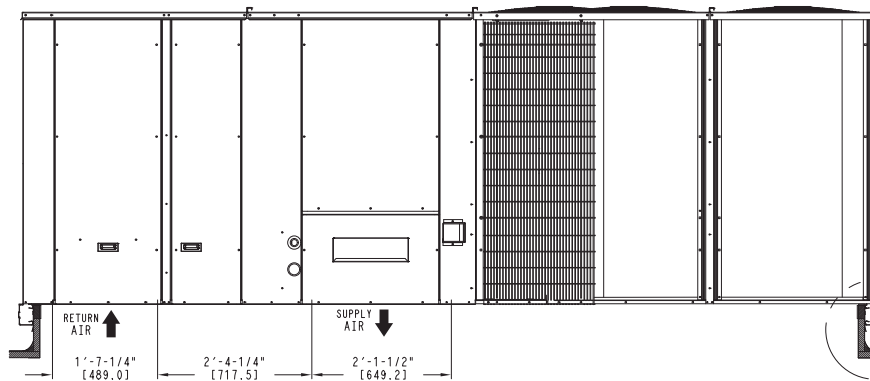

## OPTIONS AND ACCESSORIES WEIGHT ADDERS

BASE UNIT WITH OPTIONS AND ACCESSORIES (Weight Adders)	MAX WEIGHT ADD							
	RGH181/183		RGH210/213		RGH240/243		RGH300/303	
	lb	kg	lb	kg	lb	kg	lb	kg
Base Unit Operating Weight	1892	858	2102	953	2247	1019	2292	1040
Power Exhaust	125	57	125	57	125	57	125	57
Economizer	170	77	170	77	170	77	195	88
Copper Tube/Fin Evaporator Coil	110	50	110	50	135	61	161	73
Low Gas Heat	85	39	85	39	85	39	85	39
Medium Gas Heat	90	41	90	41	90	41	90	41
High Gas Heat	113	51	113	51	113	51	113	51
Flue Discharge Deflector	7	3	7	3	7	3	7	3
Roof Curb 14-in (356mm)	240	109	240	109	240	109	255	116
Roof Curb 24-in (610mm)	340	154	340	154	340	154	355	161
Louvered Hail Guard	60	27	60	27	120	54	150	68
CO <sub>2</sub> sensor	5	2	5	2	5	2	5	2
Supply Smoke Detector	5	2	5	2	5	2	5	2
Fan/Filter Status Switch	2	1	2	1	2	1	2	1
Non-Fused Disconnect	15	7	15	7	15	7	15	7
Non-Powered Convenience Outlet	5	2	5	2	5	2	5	2
Enthalpy Sensor	2	1	2	1	2	1	2	1
Differential Enthalpy Sensor	3	1	3	1	3	1	3	1
Two Position Motorized Damper	50	23	50	23	50	23	65	29
Manual Damper	35	16	35	16	35	16	40	18
Field Filter Track 4-in (102mm)	12	5	12	5	12	5	18	8
MotorMaster Controller	35	16	35	16	35	16	35	16
Standard Static Motor/Drive	0	0	0	0	0	0	0	0
Medium Static Motor/Drive	5	2	6	3	6	3	6	3
High Static Motor/Drive	11	5	12	5	16	7	16	7
Barometric Relief Hood (Horizontal)	25	11	25	11	25	11	25	11

# APPLICATION DATA

## Min operating ambient temp (cooling):

In mechanical cooling mode, your rooftop unit can safely operate down to an outdoor ambient temperature of 35°F (2°C). It is possible to provide cooling at lower outdoor ambient temperatures by using less outside air, economizers, and/or accessory low ambient kits.

## Max operating ambient temp (cooling):

The maximum operating ambient temperature for cooling mode is 125°F (52°C). While cooling operation above 125°F (52°C) may be possible, it could cause either a reduction in performance, reliability, or a protective action by the unit's internal safety devices.

## Min mixed air temp (heating):

Using the factory settings, the minimum temperatures for the mixed air (the combined temperature of the warm return air and the cold outdoor air) entering the dimpled, gas heat exchangers are:

<u>Aluminized</u>	<u>Stainless Steel</u>
50°F (10°C) continuous	40°F (4°C) continuous
45°F (7°C) intermittent	35°F (2°C) intermittent

Operating at lower mixed-air temperatures may be possible, if a field-supplied, outdoor air thermostat initiates both heat stages when the temperature is less than the minimum temperatures listed above. Please contact your local representative for assistance.

## Min and max airflow (heating and cooling):

To maintain safe and reliable operation of your rooftop, operate within the heating airflow limits during heating mode and cooling airflow limits during cooling mode. Operating above the max may cause blow-off, undesired airflow noise, or airflow related problems with the rooftop unit. Operating below the min may cause problems with coil freeze-up and unsafe heating operation. Heating and cooling limitations differ when evaluating operating CFM, the minimum value is the HIGHER of the cooling and heating minimum CFM values published in Table 5 and the maximum value is the LOWER of the cooling and heating minimum values published in Table 5.

## Heating-to-cooling changeover:

This unit will automatically change from heating to cooling mode when using a thermostat with an auto-change-over feature.

## Airflow:

All units are draw-through in cooling mode and blow-through in heating mode.

## Outdoor air application strategies:

Economizers reduce operating expenses and compressor run time by providing a free source of cooling and a means of ventilation to match application changing needs. In fact, they should be considered for most applications. Also, consider the various economizer control methods and their benefits, as well as sensors required to accomplish your application goals.

## Motor limits, break horsepower (BHP):

Due to internal design of units, the air path, and specially designed motors, the full horsepower (maximum continuous BHP) band can be used with the utmost confidence. There is no need for extra safety factors, as motors are designed and rigorously tested to use the entire, listed BHP range without either nuisance tripping or premature motor failure.

## Propane heating:

Propane has different physical qualities than natural gas. As a result, propane requires different fuel to air mixture. To optimize the fuel/air mixture for propane, a kit with different burner orifices in an easy to install accessory. To select the correct burner orifices or determine the heat capacity for a propane application, use either the selection software, or the unit's service manual.

## High altitude heating:

High altitudes have less oxygen, which affects the fuel/air mixture in heat exchangers. In order to maintain a proper fuel/air mixture, heat exchangers operating in altitudes above 2000 ft (610 m) require different orifices. To select the correct burner orifices or determine the heat capacity for a high altitude application, use either the selection software, or the unit's service manual.

High altitudes have less oxygen, which means heat exchangers need less fuel. The new gas orifices in this field-installed kit make the necessary adjustment for high altitude applications. They restore the optimal fuel to air mixture and maintain healthy combustion on altitudes above 2000 ft (610 m).

**NOTE:** Typical natural gas heating value ranges from 975 to 1050 Btu/ft<sup>3</sup> at sea level nationally. The heating value goes down approximately 1.7% per every thousand feet elevation. Standard factory orifices can typically be used up to 2000 ft (610m) elevation without any operational issues.

**NOTE:** For installations in Canada, the input rating should be derated by 10% for altitudes from 2000 ft (610m) to 4500 ft (1372m) above sea level.

## Sizing a rooftop

While an air conditioner needs to have enough capacity to meet the design loads, it doesn't need excess capacity. In fact, excess capacity typically results in very poor part load performance and humidity control.

Using higher design temperatures than ASHRAE recommends for your location, adding "safety factors" to the calculated load, are all signs of oversizing air conditioners. Oversizing the air conditioner leads to poor humidity control, reduced efficiency, higher utility bills, larger indoor temperature swings, excessive noise, and increased wear and tear on the air conditioner.

Rather than oversizing an air conditioner, engineers should "right-size" or even slightly undersize air conditioners. Correctly sizing an air conditioner controls humidity better; promotes efficiency; reduces utility bills; extends equipment life, and maintains even, comfortable temperatures.

## Low ambient applications

The optional economizer can adequately cool your space by bringing in fresh, cool outside air. In fact, when so equipped, accessory low-ambient kit may not be necessary. In low ambient conditions, unless the outdoor air is excessively humid or contaminated, economizer-based "free cooling" is the preferred less costly and energy conscious method.

In low ambient applications where outside air might not be desired (such as contaminated or excessively humid outdoor environments), your rooftop can operate to ambient temperatures down to -20°F (-29°C) using the recommended accessory Motormaster low ambient controller or down to 25°F (-4°C) with the field installed Winter Start Package.

**Table 8 – COOLING CAPACITIES 15 TONS (2 Stage Cooling)**

RGH181/183				AMBIENT TEMPERATURE														
				85			95			105			115			125		
				EA (dB)			EA (dB)			EA (dB)			EA (dB)			EA (dB)		
				75	80	85	75	80	85	75	80	85	75	80	85	75	80	85
4500 CFM	EAT (wb)	58	TC	158.3	158.3	179.2	152.6	152.6	172.9	146.6	146.6	166.1	140.2	140.2	158.8	133.2	133.2	150.8
			SHC	137.3	158.3	179.2	132.4	152.6	172.9	127.2	146.6	166.1	121.6	140.2	158.8	115.5	133.2	150.8
		62	TC	166.8	166.8	169.0	159.5	159.5	165.6	151.8	151.8	161.9	143.6	143.6	157.9	134.9	134.9	153.4
			SHC	123.1	146.1	169.0	119.7	142.6	165.6	116.1	139.0	161.9	112.3	135.1	157.9	108.2	130.8	153.4
		67	TC	182.9	182.9	182.9	174.9	174.9	174.9	166.3	166.3	166.3	157.2	157.2	157.2	147.6	147.6	147.6
			SHC	100.0	123.1	146.1	96.7	119.8	142.8	93.2	116.3	139.4	89.7	112.7	135.7	85.9	108.9	131.9
		72	TC	200.5	200.5	200.5	191.6	191.6	191.6	182.2	182.2	182.2	172.2	172.2	172.2	161.7	161.7	161.7
			SHC	76.1	99.5	122.8	72.9	96.2	119.5	69.5	92.8	116.1	66.0	89.3	112.5	62.4	85.6	108.8
		76	TC	–	215.4	215.4	–	205.8	205.8	–	195.6	195.6	–	184.8	184.8	–	173.6	173.6
			SHC	–	80.2	105.0	–	77.1	101.7	–	73.7	98.2	–	70.2	94.5	–	66.7	90.7
5250 CFM	EAT (wb)	58	TC	166.7	166.7	188.8	160.6	160.6	181.9	154.0	154.0	174.4	147.0	147.0	166.5	139.5	139.5	157.9
			SHC	144.6	166.7	188.8	139.3	160.6	181.9	133.6	154.0	174.4	127.6	147.0	166.5	121.0	139.5	157.9
		62	TC	172.0	172.0	185.1	164.3	164.3	181.2	156.3	156.3	177.0	147.8	147.8	172.4	139.6	139.6	164.3
			SHC	132.5	158.8	185.1	128.9	155.1	181.2	125.0	151.0	177.0	120.9	146.6	172.4	114.9	139.6	164.3
		67	TC	188.3	188.3	188.3	179.7	179.7	179.7	170.7	170.7	170.7	161.0	161.0	161.0	150.9	150.9	150.9
			SHC	106.1	132.7	159.3	102.8	129.3	155.9	99.3	125.8	152.4	95.6	122.1	148.6	91.7	118.2	144.7
		72	TC	206.1	206.1	206.1	196.7	196.7	196.7	186.7	186.7	186.7	176.2	176.2	176.2	165.3	165.3	165.3
			SHC	78.8	105.6	132.5	75.5	102.3	129.1	72.1	98.8	125.6	68.5	95.2	121.9	64.8	91.4	118.0
		76	TC	–	221.2	221.2	–	211.0	211.0	–	200.3	200.3	–	189.0	189.0	–	177.2	177.2
			SHC	–	83.6	111.7	–	80.3	108.2	–	76.9	104.6	–	73.3	100.9	–	69.7	97.1
6000 CFM	EAT (wb)	58	TC	173.8	173.8	196.8	167.2	167.2	189.4	160.2	160.2	181.4	152.7	152.7	173.0	144.7	144.7	163.8
			SHC	150.8	173.8	196.8	145.1	167.2	189.4	139.0	160.2	181.4	132.5	152.7	173.0	125.5	144.7	163.8
		62	TC	176.3	176.3	199.5	168.5	168.5	194.9	160.5	160.5	188.9	152.9	152.9	179.9	144.8	144.8	170.4
			SHC	140.9	170.2	199.5	136.9	165.9	194.9	132.1	160.5	188.9	125.8	152.9	179.9	119.2	144.8	170.4
		67	TC	192.3	192.3	192.3	183.4	183.4	183.4	173.9	173.9	173.9	164.0	164.0	164.0	153.4	153.4	156.9
			SHC	112.0	142.0	172.0	108.5	138.5	168.5	104.9	134.9	164.8	101.2	131.1	161.0	97.2	127.1	156.9
		72	TC	210.4	210.4	210.4	200.6	200.6	200.6	190.2	190.2	190.2	179.3	179.3	179.3	167.9	167.9	167.9
			SHC	81.2	111.4	141.7	77.9	108.0	138.2	74.4	104.5	134.6	70.7	100.8	130.8	67.0	96.9	126.9
		76	TC	–	225.6	225.6	–	215.0	215.0	–	203.8	203.8	–	192.1	192.1	–	180.0	180.0
			SHC	–	86.7	117.9	–	83.3	114.5	–	79.9	110.8	–	76.3	107.1	–	72.6	103.2
6750 CFM	EAT (wb)	58	TC	179.8	179.8	203.7	172.9	172.9	195.8	165.5	165.5	187.4	157.5	157.5	178.4	149.0	149.0	168.8
			SHC	156.0	179.8	203.7	150.0	172.9	195.8	143.5	165.5	187.4	136.7	157.5	178.4	129.3	149.0	168.8
		62	TC	180.5	180.5	210.7	173.0	173.0	203.6	165.6	165.6	194.9	157.7	157.7	185.5	149.1	149.1	175.5
			SHC	147.6	179.2	210.7	142.4	173.0	203.6	136.3	165.6	194.9	129.8	157.7	185.5	122.8	149.1	175.5
		67	TC	195.6	195.6	195.6	186.2	186.2	186.2	176.5	176.5	176.8	166.2	166.2	172.7	155.4	155.4	168.4
			SHC	117.5	150.8	184.1	114.0	147.3	180.5	110.4	143.6	176.8	106.5	139.6	172.7	102.4	135.4	168.4
		72	TC	213.8	213.8	213.8	203.6	203.6	203.6	192.9	192.9	192.9	181.6	181.6	181.6	169.9	169.9	169.9
			SHC	83.5	117.0	150.5	80.1	113.5	147.0	76.5	109.9	143.3	72.8	106.1	139.4	69.1	102.3	135.5
		76	TC	–	229.1	229.1	–	218.1	218.1	–	206.6	206.6	–	194.6	194.6	–	182.1	182.1
			SHC	–	89.6	124.0	–	86.2	120.5	–	82.7	116.8	–	79.0	113.0	–	75.2	109.0
7500 CFM	EAT (wb)	58	TC	185.1	185.1	209.6	177.7	177.7	201.3	170.0	170.0	192.5	161.6	161.6	183.0	152.8	152.8	173.0
			SHC	160.6	185.1	209.6	154.2	177.7	201.3	147.5	170.0	192.5	140.2	161.6	183.0	132.5	152.8	173.0
		62	TC	185.2	185.2	218.0	177.9	177.9	209.3	170.1	170.1	200.2	161.8	161.8	190.4	152.9	152.9	179.9
			SHC	152.5	185.2	218.0	146.4	177.9	209.3	140.0	170.1	200.2	133.2	161.8	190.4	125.8	152.9	179.9
		67	TC	198.1	198.1	198.1	188.6	188.6	192.1	178.6	178.6	188.1	168.1	168.1	183.8	157.2	157.2	179.1
			SHC	122.8	159.3	195.9	119.2	155.7	192.1	115.5	151.8	188.1	111.5	147.7	183.8	107.3	143.2	179.1
		72	TC	216.6	216.6	216.6	206.1	206.1	206.1	195.1	195.1	195.1	183.5	183.5	183.5	171.6	171.6	171.6
			SHC	85.6	122.3	159.0	82.2	118.8	155.5	78.6	115.2	151.7	74.9	111.3	147.8	71.1	107.4	143.8
		76	TC	–	231.9	231.9	–	220.7	220.7	–	208.9	208.9	–	196.5	196.5	–	183.8	183.8
			SHC	–	92.4	129.9	–	88.9	126.3	–	85.4	122.6	–	81.6	118.7	–	77.8	114.6

**LEGEND:**

- Do not operate
- Cfm – Cubic feet per minute (supply air)
- EAT(db) – Entering air temperature (dry bulb)
- EAT(wb) – Entering air temperature (wet bulb)
- SHC – Sensible heat capacity
- TC – Total capacity



**Table 9 – COOLING CAPACITIES 17.5 TONS (2 Stage Cooling)**

RGH210/213				AMBIENT TEMPERATURE														
				85			95			105			115			125		
				EA (dB)			EA (dB)			EA (dB)			EA (dB)			EA (dB)		
				75	80	85	75	80	85	75	80	85	75	80	85	75	80	85
5250 CFM	EAT (wb)	58	TC	185.1	185.1	209.2	178.7	178.7	201.9	171.8	171.8	194.1	164.5	164.5	185.8	156.7	156.7	177.0
			SHC	161.1	185.1	209.2	155.4	178.7	201.9	149.4	171.8	194.1	143.1	164.5	185.8	136.3	156.7	177.0
		62	TC	193.8	193.8	199.5	185.6	185.6	195.4	176.9	176.9	191.1	167.7	167.7	186.4	158.2	158.2	181.1
			SHC	145.6	172.6	199.5	141.7	168.6	195.4	137.6	164.4	191.1	133.2	159.8	186.4	128.3	154.7	181.1
		67	TC	212.2	212.2	212.2	203.3	203.3	203.3	193.8	193.8	193.8	183.8	183.8	183.8	173.1	173.1	173.1
	SHC		119.0	146.0	173.1	115.3	142.3	169.4	111.4	138.4	165.4	107.3	134.3	161.3	103.0	130.0	157.0	
	72	TC	232.3	232.3	232.3	222.7	222.7	222.7	212.4	212.4	212.4	201.6	201.6	201.6	190.1	190.1	190.1	
		SHC	91.5	118.8	146.2	87.9	115.2	142.5	84.1	111.4	138.7	80.2	107.4	134.6	76.0	103.2	130.4	
	76	TC	–	249.5	249.5	–	239.2	239.2	–	228.2	228.2	–	216.6	216.6	–	204.3	204.3	
		SHC	–	96.7	125.3	–	93.2	121.7	–	89.5	117.9	–	85.6	113.8	–	81.5	109.5	
6125 CFM	EAT (wb)	58	TC	194.7	194.7	220.0	187.8	187.8	212.2	180.4	180.4	203.8	172.5	172.5	194.9	164.1	164.1	185.5
			SHC	169.4	194.7	220.0	163.3	187.8	212.2	156.9	180.4	203.8	150.1	172.5	194.9	142.8	164.1	185.5
		62	TC	199.6	199.6	218.0	191.1	191.1	213.5	182.1	182.1	208.4	173.0	173.0	201.2	164.3	164.3	192.8
			SHC	156.5	187.2	218.0	152.3	182.9	213.5	147.7	178.0	208.4	141.8	171.5	201.2	135.8	164.3	192.8
		67	TC	218.0	218.0	218.0	208.7	208.7	208.7	198.7	198.7	198.7	188.2	188.2	188.2	177.1	177.1	177.1
	SHC		126.2	157.4	188.6	122.4	153.6	184.7	118.4	149.6	180.7	114.3	145.4	176.5	109.9	141.0	172.1	
	72	TC	238.5	238.5	238.5	228.4	228.4	228.4	217.7	217.7	217.7	206.3	206.3	206.3	194.3	194.3	194.3	
		SHC	94.7	126.1	157.5	91.0	122.4	153.8	87.2	118.5	149.8	83.1	114.4	145.7	78.9	110.1	141.4	
	76	TC	–	255.9	255.9	–	245.1	245.1	–	233.6	233.6	–	221.4	221.4	–	208.5	208.5	
		SHC	–	100.7	133.3	–	97.1	129.6	–	93.3	125.6	–	89.3	121.5	–	85.1	117.1	
7000 CFM	EAT (wb)	58	TC	202.7	202.7	229.1	195.4	195.4	220.8	187.5	187.5	211.9	179.2	179.2	202.5	170.3	170.3	192.4
			SHC	176.4	202.7	229.1	170.0	195.4	220.8	163.1	187.5	211.9	155.9	179.2	202.5	148.1	170.3	192.4
		62	TC	204.6	204.6	234.4	196.0	196.0	228.0	187.7	187.7	220.3	179.3	179.3	210.5	170.4	170.4	200.0
			SHC	166.0	200.2	234.4	160.8	194.4	228.0	155.1	187.7	220.3	148.2	179.3	210.5	140.8	170.4	200.0
		67	TC	222.5	222.5	222.5	212.8	212.8	212.8	202.4	202.4	202.4	191.5	191.5	191.5	180.0	180.0	186.4
	SHC		133.0	168.2	203.4	129.2	164.3	199.5	125.1	160.3	195.4	120.9	156.0	191.0	116.4	151.4	186.4	
	72	TC	243.3	243.3	243.3	232.7	232.7	232.7	221.6	221.6	221.6	209.9	209.9	209.9	197.4	197.4	197.4	
		SHC	97.5	132.9	168.3	93.8	129.2	164.5	89.9	125.2	160.5	85.8	121.1	156.3	81.6	116.7	151.9	
	76	TC	–	260.8	260.8	–	249.6	249.6	–	237.7	237.7	–	225.1	225.1	–	211.7	211.7	
		SHC	–	104.4	140.8	–	100.7	137.0	–	96.9	133.0	–	92.8	128.8	–	88.5	124.4	
7875 CFM	EAT (wb)	58	TC	209.6	209.6	236.8	201.8	201.8	228.1	193.6	193.6	218.8	184.8	184.8	208.9	175.5	175.5	198.3
			SHC	182.3	209.6	236.8	175.6	201.8	228.1	168.4	193.6	218.8	160.8	184.8	208.9	152.7	175.5	198.3
		62	TC	209.8	209.8	246.2	202.0	202.0	237.1	193.8	193.8	227.4	185.0	185.0	217.1	175.6	175.6	206.1
			SHC	173.4	209.8	246.2	167.0	202.0	237.1	160.1	193.8	227.4	152.9	185.0	217.1	145.1	175.6	206.1
		67	TC	226.1	226.1	226.1	216.0	216.0	216.0	205.4	205.4	209.4	194.2	194.2	204.8	182.4	182.4	199.9
	SHC		139.6	178.6	217.7	135.6	174.7	213.7	131.5	170.5	209.4	127.1	166.0	204.8	122.5	161.2	199.9	
	72	TC	247.0	247.0	247.0	236.2	236.2	236.2	224.7	224.7	224.7	212.7	212.7	212.7	199.9	199.9	199.9	
		SHC	100.2	139.5	178.8	96.5	135.7	174.9	92.5	131.7	170.9	88.4	127.5	166.6	84.1	123.1	162.1	
	76	TC	–	264.7	264.7	–	253.1	253.1	–	240.9	240.9	–	227.9	227.9	–	–	–	
		SHC	–	107.9	148.1	–	104.2	144.3	–	100.2	140.2	–	96.1	135.9	–	–	–	
8750 CFM	EAT (wb)	58	TC	215.4	215.4	243.4	207.3	207.3	234.3	198.7	198.7	224.6	189.6	189.6	214.2	179.9	179.9	203.2
			SHC	187.4	215.4	243.4	180.3	207.3	234.3	172.9	198.7	224.6	164.9	189.6	214.2	156.5	179.9	203.2
		62	TC	215.5	215.5	253.0	207.5	207.5	243.5	198.9	198.9	233.4	189.7	189.7	222.7	180.0	180.0	211.2
			SHC	178.1	215.5	253.0	171.5	207.5	243.5	164.4	198.9	233.4	156.8	189.7	222.7	148.8	180.0	211.2
		67	TC	228.9	228.9	231.5	218.7	218.7	227.3	207.8	207.8	222.8	196.4	196.4	217.9	184.5	184.5	212.6
	SHC		145.8	188.6	231.5	141.8	184.5	227.3	137.5	180.1	222.8	133.0	175.5	217.9	128.2	170.4	212.6	
	72	TC	250.1	250.1	250.1	239.0	239.0	239.0	227.3	227.3	227.3	214.9	214.9	214.9	201.8	201.8	201.8	
		SHC	102.8	145.8	188.9	99.0	142.0	185.0	95.0	137.9	180.9	90.8	133.7	176.5	86.4	129.2	172.0	
	76	TC	–	267.8	267.8	–	256.0	256.0	–	243.5	243.5	–	230.2	230.2	–	–	–	
		SHC	–	111.2	155.2	–	107.4	151.3	–	103.5	147.1	–	99.3	142.8	–	–	–	

**LEGEND:**

- Do not operate
- Cfm – Cubic feet per minute (supply air)
- EAT(db) – Entering air temperature (dry bulb)
- EAT(wb) – Entering air temperature (wet bulb)
- SHC – Sensible heat capacity
- TC – Total capacity

**Table 10 – COOLING CAPACITIES 20 TONS (2 Stage Cooling)**

RGH240/243				AMBIENT TEMPERATURE														
				85			95			105			115			125		
				EA (dB)			EA (dB)			EA (dB)			EA (dB)			EA (dB)		
				75	80	85	75	80	85	75	80	85	75	80	85	75	80	85
6000 CFM	EAT (wb)	58	TC	214.4	214.4	242.5	207.0	207.0	234.2	118.0	118.0	143.5	190.2	190.2	215.2	180.6	180.6	204.3
			SHC	186.3	214.4	242.5	179.9	207.0	234.2	92.5	118.0	143.5	165.3	190.2	215.2	157.0	180.6	204.3
		62	TC	226.8	226.8	227.7	217.3	217.3	223.0	120.7	120.7	147.0	195.8	195.8	212.5	183.7	183.7	206.4
			SHC	167.0	197.3	227.7	162.4	192.7	223.0	83.2	115.1	147.0	152.3	182.4	212.5	146.6	176.5	206.4
		67	TC	248.4	248.4	248.4	237.9	237.9	237.9	137.4	137.4	137.4	214.3	214.3	214.3	201.0	201.0	201.0
			SHC	136.5	167.1	197.6	132.2	162.7	193.2	66.4	98.7	131.1	122.5	152.9	183.4	117.2	147.6	178.0
		72	TC	271.9	271.9	271.9	260.3	260.3	260.3	155.8	155.8	155.8	234.5	234.5	234.5	220.1	220.1	220.1
			SHC	105.1	136.0	167.0	100.8	131.7	162.5	48.7	81.1	113.5	91.4	122.1	152.9	86.3	116.9	147.6
		76	TC	–	291.7	291.7	–	279.2	279.2	–	168.8	168.8	–	251.3	251.3	–	235.8	235.8
			SHC	–	110.7	143.7	–	106.5	139.5	–	65.6	98.6	–	97.2	129.7	–	92.1	124.3
7000 CFM	EAT (wb)	58	TC	225.8	225.8	255.3	217.8	217.8	246.3	126.2	126.2	153.5	199.6	199.6	225.7	189.2	189.2	214.0
			SHC	196.2	225.8	255.3	189.3	217.8	246.3	99.0	126.2	153.5	173.4	199.6	225.7	164.4	189.2	214.0
		62	TC	233.9	233.9	248.8	223.8	223.8	243.8	126.8	126.8	160.9	201.4	201.4	231.8	190.0	190.0	221.5
			SHC	179.4	214.1	248.8	174.6	209.2	243.8	89.3	125.1	160.9	163.7	197.8	231.8	155.9	188.7	221.5
		67	TC	255.7	255.7	255.7	244.6	244.6	244.6	142.4	142.4	145.3	219.6	219.6	219.6	205.7	205.7	205.7
			SHC	144.7	179.7	214.8	140.2	175.2	210.2	70.3	107.8	145.3	130.3	165.2	200.2	124.9	159.8	194.7
		72	TC	279.4	279.4	279.4	267.3	267.3	267.3	160.9	160.9	160.9	240.1	240.1	240.1	224.9	224.9	224.9
			SHC	108.7	144.1	179.6	104.3	139.7	175.1	49.3	86.9	124.4	94.7	129.9	165.1	89.5	124.6	159.7
		76	TC	–	299.4	299.4	–	286.2	286.2	–	172.1	172.1	–	256.9	256.9	–	240.7	240.7
			SHC	–	115.3	152.9	–	110.9	148.2	–	68.2	106.2	–	101.3	138.0	–	96.1	132.6
8000 CFM	EAT (wb)	58	TC	235.3	235.3	266.2	226.8	226.8	256.5	133.2	133.2	161.9	207.4	207.4	234.5	196.3	196.3	222.0
			SHC	204.5	235.3	266.2	197.1	226.8	256.5	104.5	133.2	161.9	180.2	207.4	234.5	170.6	196.3	222.0
		62	TC	239.7	239.7	268.1	229.4	229.4	262.0	133.4	133.4	171.8	208.3	208.3	241.9	196.7	196.7	231.0
			SHC	190.7	229.4	268.1	185.4	223.7	262.0	95.0	133.4	171.8	170.4	206.2	241.9	162.3	196.7	231.0
		67	TC	261.3	261.3	261.3	249.6	249.6	249.6	146.4	146.4	159.1	223.6	223.6	223.6	209.2	209.2	210.6
			SHC	152.3	191.8	231.2	147.7	187.1	226.6	73.9	116.5	159.1	137.7	177.0	216.3	132.2	171.4	210.6
		72	TC	285.3	285.3	285.3	272.5	272.5	272.5	164.6	164.6	164.6	244.2	244.2	244.2	228.6	228.6	228.6
			SHC	111.9	151.7	191.5	107.5	147.2	186.9	49.7	92.1	134.5	97.7	137.2	176.7	92.4	131.8	171.2
		76	TC	–	305.4	305.4	–	291.6	291.6	–	174.2	174.2	–	261.2	261.2	–	244.4	244.4
			SHC	–	119.4	161.0	–	114.9	156.2	–	70.5	113.0	–	105.1	146.0	–	99.8	140.4
9000 CFM	EAT (wb)	58	TC	243.5	243.5	275.4	234.5	234.5	265.2	139.2	139.2	169.2	213.9	213.9	241.9	202.3	202.3	228.8
			SHC	211.6	243.5	275.4	203.8	234.5	265.2	109.1	139.2	169.2	185.9	213.9	241.9	175.8	202.3	228.8
		62	TC	245.4	245.4	282.9	235.4	235.4	274.6	139.4	139.4	179.5	214.4	214.4	251.7	202.5	202.5	237.8
			SHC	199.7	241.3	282.9	193.2	233.9	274.6	99.2	139.4	179.5	176.8	214.3	251.7	167.1	202.5	237.8
		67	TC	265.6	265.6	265.6	253.6	253.6	253.6	149.5	149.5	172.3	226.8	226.8	231.8	212.0	212.0	225.8
			SHC	159.6	203.3	247.1	154.9	198.6	242.3	77.2	124.7	172.3	144.7	188.3	231.8	139.0	182.4	225.8
		72	TC	289.9	289.9	289.9	276.7	276.7	276.7	166.9	166.9	166.9	247.5	247.5	247.5	231.4	231.4	231.4
			SHC	114.9	159.0	203.0	110.4	154.4	198.3	49.7	96.7	143.7	100.5	144.2	188.0	95.2	138.7	182.3
		76	TC	–	310.1	310.1	–	295.8	295.8	–	175.6	175.6	–	264.4	264.4	–	247.3	247.3
			SHC	–	123.2	168.9	–	118.6	164.1	–	72.4	118.9	–	108.7	153.6	–	103.4	147.9
10,000 CFM	EAT (wb)	58	TC	250.4	250.4	283.2	240.9	240.9	272.5	144.4	144.4	175.5	219.5	219.5	248.2	207.3	207.3	234.5
			SHC	217.7	250.4	283.2	209.4	240.9	272.5	113.2	144.4	175.5	190.7	219.5	248.2	180.2	207.3	234.5
		62	TC	250.8	250.8	294.6	241.1	241.1	283.3	144.6	144.6	186.2	219.6	219.6	258.0	207.5	207.5	243.7
			SHC	207.0	250.8	294.6	199.0	241.1	283.3	103.0	144.6	186.2	181.2	219.6	258.0	171.2	207.5	243.7
		67	TC	269.2	269.2	269.2	256.8	256.8	257.6	152.3	152.3	185.0	229.4	229.4	246.4	214.3	214.3	240.0
			SHC	166.6	214.5	262.5	161.9	209.7	257.6	80.4	132.7	185.0	151.3	198.9	246.4	145.5	192.8	240.0
		72	TC	293.7	293.7	293.7	280.1	280.1	280.1	168.6	168.6	168.6	250.2	250.2	250.2	233.7	233.7	233.7
			SHC	117.8	166.0	214.2	113.2	161.3	209.3	49.7	101.0	152.4	103.2	151.0	198.8	97.8	145.4	193.1
		76	TC	–	313.9	313.9	–	299.3	299.3	–	176.8	176.8	–	267.1	267.1	–	249.6	249.6
			SHC	–	126.8	176.5	–	122.2	171.6	–	74.3	124.7	–	112.1	161.0	–	106.7	155.1

**LEGEND:**

- Do not operate
- Cfm – Cubic feet per minute (supply air)
- EAT(db) – Entering air temperature (dry bulb)
- EAT(wb) – Entering air temperature (wet bulb)
- SHC – Sensible heat capacity
- TC – Total capacity

**Table 11 – COOLING CAPACITIES 25 TONS (2 Stage Cooling)**

RGH300/303				AMBIENT TEMPERATURE															
				85			95			105			115			125			
				EA (dB)			EA (dB)			EA (dB)			EA (dB)			EA (dB)			
				75	80	85	75	80	85	75	80	85	75	80	85	75	80	85	
7,500 CFM	EAT (wb)	58	TC	264.4	264.4	298.9	254.6	254.6	287.9	244.1	244.1	276.0	232.7	232.7	263.1	220.3	220.3	249.1	
			SHC	229.9	264.4	298.9	221.4	254.6	287.9	212.2	244.1	276.0	202.3	232.7	263.1	191.5	220.3	249.1	
		62	TC	278.7	278.7	282.4	266.3	266.3	276.4	252.8	252.8	269.8	238.5	238.5	262.4	223.9	223.9	251.3	
			SHC	206.8	244.6	282.4	200.9	238.7	276.4	194.6	232.2	269.8	187.7	225.0	262.4	178.7	215.0	251.3	
		67	TC	305.3	305.3	305.3	291.9	291.9	291.9	277.3	277.3	277.3	261.5	261.5	261.5	244.5	244.5	244.5	
			SHC	169.0	207.0	245.0	163.4	201.4	239.4	157.4	195.3	233.3	151.0	188.9	226.8	144.2	182.1	219.9	
	72	TC	334.0	334.0	334.0	319.4	319.4	319.4	303.6	303.6	303.6	286.5	286.5	286.5	268.1	268.1	268.1		
		SHC	129.9	168.5	207.1	124.5	163.0	201.5	118.7	157.1	195.5	112.5	150.8	189.2	106.0	144.2	182.3		
	76	TC	–	358.2	358.2	–	342.4	342.4	–	325.4	325.4	–	307.1	307.1	–	287.4	287.4		
		SHC	–	137.0	178.2	–	131.7	172.9	–	126.0	166.9	–	119.9	160.4	–	113.4	153.4		
	8,750 CFM	EAT (wb)	58	TC	278.2	278.2	314.5	267.8	267.8	302.8	256.5	256.5	289.9	244.2	244.2	276.1	230.8	230.8	261.0
				SHC	241.9	278.2	314.5	232.8	267.8	302.8	223.0	256.5	289.9	212.3	244.2	276.1	200.7	230.8	261.0
62			TC	287.2	287.2	308.3	274.3	274.3	301.5	260.8	260.8	291.7	247.0	247.0	280.9	232.0	232.0	269.1	
			SHC	222.1	265.2	308.3	215.7	258.6	301.5	207.7	249.7	291.7	199.0	240.0	280.9	189.7	229.4	269.1	
67			TC	314.0	314.0	314.0	299.8	299.8	299.8	284.4	284.4	284.4	267.8	267.8	267.8	250.0	250.0	250.0	
			SHC	179.1	222.7	266.4	173.3	216.9	260.6	167.2	210.8	254.3	160.7	204.2	247.7	153.7	197.2	240.6	
72		TC	343.0	343.0	343.0	327.7	327.7	327.7	311.1	311.1	311.1	293.1	293.1	293.1	273.8	273.8	273.8		
		SHC	134.3	178.5	222.6	128.8	172.9	216.9	122.9	166.9	210.8	116.6	160.4	204.3	109.9	153.6	197.3		
76		TC	–	367.3	367.3	–	350.8	350.8	–	333.0	333.0	–	313.8	313.8	–	293.2	293.2		
		SHC	–	142.6	189.4	–	137.1	183.5	–	131.2	177.3	–	125.0	170.7	–	118.4	163.7		
10,000 CFM		EAT (wb)	58	TC	289.7	289.7	327.5	278.7	278.7	315.0	266.6	266.6	301.4	253.6	253.6	286.7	239.4	239.4	270.7
				SHC	251.9	289.7	327.5	242.3	278.7	315.0	231.8	266.6	301.4	220.5	253.6	286.7	208.2	239.4	270.7
	62		TC	294.6	294.6	329.6	282.2	282.2	319.7	268.7	268.7	309.1	254.1	254.1	298.4	239.7	239.7	281.4	
			SHC	234.7	282.1	329.6	226.8	273.3	319.7	218.4	263.7	309.1	209.7	254.1	298.4	197.9	239.7	281.4	
	67		TC	320.6	320.6	320.6	305.9	305.9	305.9	289.9	289.9	289.9	272.7	272.7	272.7	254.3	254.3	260.3	
			SHC	188.6	237.7	286.8	182.7	231.8	280.9	176.5	225.5	274.5	169.8	218.8	267.7	162.8	211.5	260.3	
	72	TC	350.0	350.0	350.0	334.0	334.0	334.0	316.8	316.8	316.8	298.2	298.2	298.2	278.3	278.3	278.3		
		SHC	138.4	187.9	237.5	132.8	182.2	231.7	126.8	176.1	225.5	120.4	169.6	218.8	113.6	162.6	211.7		
	76	TC	–	374.4	374.4	–	357.3	357.3	–	338.7	338.7	–	318.9	318.9	–	297.5	297.5		
		SHC	–	147.7	199.5	–	142.1	193.7	–	136.1	187.4	–	129.7	180.6	–	123.0	173.5		
	11,250 CFM	EAT (wb)	58	TC	299.4	299.4	338.4	287.8	287.8	325.4	275.2	275.2	311.1	261.4	261.4	295.6	246.6	246.6	278.8
				SHC	260.3	299.4	338.4	250.2	287.8	325.4	239.2	275.2	311.1	227.3	261.4	295.6	214.4	246.6	278.8
62			TC	302.2	302.2	346.0	289.3	289.3	335.7	275.5	275.5	323.5	262.1	262.1	307.7	246.8	246.8	289.8	
			SHC	244.8	295.4	346.0	236.7	286.2	335.7	227.5	275.5	323.5	216.4	262.1	307.7	203.8	246.8	289.8	
67			TC	325.9	325.9	325.9	310.7	310.7	310.7	294.2	294.2	294.2	276.6	276.6	286.7	257.7	257.7	278.9	
			SHC	197.6	252.1	306.5	191.7	246.1	300.4	185.3	239.6	293.9	178.5	232.6	286.7	171.2	225.1	278.9	
72		TC	355.5	355.5	355.5	339.1	339.1	339.1	321.3	321.3	321.3	302.2	302.2	302.2	281.8	281.8	281.8		
		SHC	142.1	197.0	251.8	136.4	191.2	245.9	130.4	185.0	239.6	123.9	178.3	232.8	117.1	171.3	225.5		
76		TC	–	380.0	380.0	–	362.4	362.4	–	343.3	343.3	–	322.8	322.8	–	300.9	300.9		
		SHC	–	152.4	209.4	–	146.8	203.4	–	140.7	197.0	–	134.2	190.2	–	127.3	182.8		
12,500 CFM		EAT (wb)	58	TC	307.7	307.7	347.9	295.7	295.7	334.2	282.5	282.5	319.3	268.2	268.2	303.2	252.7	252.7	285.7
				SHC	267.6	307.7	347.9	257.1	295.7	334.2	245.6	282.5	319.3	233.2	268.2	303.2	219.7	252.7	285.7
	62		TC	308.4	308.4	362.2	295.9	295.9	347.4	283.1	283.1	332.4	268.4	268.4	315.2	252.8	252.8	296.9	
			SHC	254.6	308.4	362.2	244.4	295.9	347.4	233.8	283.1	332.4	221.7	268.4	315.2	208.8	252.8	296.9	
	67		TC	330.2	330.2	330.2	314.6	314.6	319.2	297.8	297.8	312.3	279.8	279.8	304.7	260.6	260.6	295.9	
			SHC	206.3	265.9	325.5	200.3	259.7	319.2	193.8	253.1	312.3	186.7	245.7	304.7	179.0	237.4	295.9	
	72	TC	360.1	360.1	360.1	343.2	343.2	343.2	325.0	325.0	325.0	305.4	305.4	305.4	284.6	284.6	284.6		
		SHC	145.7	205.7	265.7	139.9	199.8	259.7	133.8	193.5	253.3	127.3	186.8	246.3	120.4	179.7	238.9		
	76	TC	–	384.6	384.6	–	366.5	366.5	–	346.9	346.9	–	325.9	325.9	–	303.5	303.5		
		SHC	–	157.0	218.9	–	151.2	212.9	–	145.1	206.3	–	138.5	199.3	–	131.5	191.7		

**LEGEND:**

- Do not operate
- Cfm – Cubic feet per minute (supply air)
- EAT(db) – Entering air temperature (dry bulb)
- EAT(wb) – Entering air temperature (wet bulb)
- SHC – Sensible heat capacity
- TC – Total capacity

**Table 12 – STATIC PRESSURE ADDERS (Factory Options and/or Accessories)**

**Economizer – Vertical and Horizontal Duct Configuration**

Model Sizes 181 – 303								
CFM	4500	5000	5500	6000	6500	7000	7500	8000
Vertical & Horizontal	0.047	0.052	0.057	0.062	0.067	0.072	0.077	0.082

Model Sizes 181 – 303									
CFM	8500	9000	9500	10000	10500	11000	11500	12000	12500
Vertical & Horizontal	0.088	0.093	0.098	0.103	0.109	0.114	0.119	0.125	0.131

**General fan performance notes:**

1. Interpolation is permissible. Do not extrapolate.
2. External static pressure is the static pressure difference between the return duct and the supply duct plus the static pressure caused by any FIOPs or accessories.
3. Tabular data accounts for pressure loss due to clean filters, high gas heat, unit casing, and wet coils. Factory options and accessories may add static pressure losses, as shown in Table 12.
4. The Fan Performance tables offer motor/drive recommendations. In cases when two motor/drive combinations would work, the lower horsepower option is recommended.
5. For information on the electrical properties of motors, please see the Electrical information section of this book.
6. For more information on the performance limits of motors, see the application data section of this book.

# FAN PERFORMANCE

Table 13 – RGH181, 15 TON VERTICAL SUPPLY / RETURN

CFM	Available External Static Pressure (in. wg)									
	0.2		0.4		0.6		0.8		1.0	
	RPM	BHP	RPM	BHP	RPM	BHP	RPM	BHP	RPM	BHP
4500	<b>490</b>	<b>0.76</b>	575	1.07	653	1.41	724	1.79	791	2.19
4900	517	0.92	597	1.24	671	1.60	740	1.99	804	2.41
5250	541	1.08	618	1.42	688	1.79	754	2.19	817	2.62
5600	566	1.26	639	1.61	707	2.00	770	2.42	831	2.86
6000	595	1.49	664	1.86	729	2.27	790	2.70	848	3.15
6400	624	1.75	690	2.14	751	2.56	810	3.01	<b>866</b>	<b>3.48</b>
6750	650	2.00	713	2.41	772	2.84	829	3.30	883	3.79
7100	<b>676</b>	<b>2.27</b>	736	2.70	793	3.15	<b>848</b>	<b>3.63</b>	901	4.13
7500	706	2.62	763	3.06	<b>819</b>	<b>3.54</b>	871	4.03	922	4.55

CFM	Available External Static Pressure (in. wg)									
	1.2		1.4		1.6		1.8		2.0	
	RPM	BHP	RPM	BHP	RPM	BHP	RPM	BHP	RPM	BHP
4500	854	2.63	913	3.09	970	3.57	<b>1024</b>	<b>4.09</b>	<b>1077</b>	<b>4.62</b>
4900	<b>865</b>	<b>2.86</b>	923	3.33	978	3.83	<b>1031</b>	<b>4.35</b>	<b>1082</b>	<b>4.89</b>
5250	876	3.08	932	3.56	986	4.07	<b>1038</b>	<b>4.60</b>	-----	-----
5600	888	3.33	943	3.82	995	4.34	<b>1046</b>	<b>4.88</b>	-----	-----
6000	903	3.64	956	4.14	1008	4.67	-----	-----	-----	-----
6400	920	3.98	971	4.50	-----	-----	-----	-----	-----	-----
6750	935	4.30	986	4.83	-----	-----	-----	-----	-----	-----
7100	952	4.65	-----	-----	-----	-----	-----	-----	-----	-----
7500	-----	-----	-----	-----	-----	-----	-----	-----	-----	-----

Std Static Motor and Drive – 514–680 RPM, Max BHP 2.2

Medium Static Motor and Drive – 679–863 RPM, Max BHP 3.3

High Static Motor and Drive – 826–1009 RPM, Max BHP 4.9

----- Outside operating range

**Boldface** – Field-supplied Drive

Table 14 – RGH210, 17.5 TON VERTICAL SUPPLY / RETURN

CFM	Available External Static Pressure (in. wg)									
	0.2		0.4		0.6		0.8		1.0	
	RPM	BHP	RPM	BHP	RPM	BHP	RPM	BHP	RPM	BHP
5250	<b>541</b>	<b>1.08</b>	<b>618</b>	<b>1.42</b>	688	1.79	754	2.19	817	2.62
5700	<b>573</b>	<b>1.31</b>	645	1.67	712	2.06	775	2.48	835	2.93
6100	<b>602</b>	<b>1.55</b>	670	1.93	734	2.34	795	2.77	852	3.23
6500	631	1.81	696	2.21	757	2.64	815	3.09	871	3.57
7000	668	2.19	729	2.61	787	3.06	843	3.53	<b>896</b>	<b>4.03</b>
7500	706	2.62	763	3.06	819	3.54	871	4.03	922	4.55
7900	736	3.00	791	3.47	844	3.96	<b>895</b>	<b>4.47</b>	944	5.00
8300	767	3.42	819	3.90	870	4.41	919	4.94	967	5.49
8750	801	3.94	852	4.44	900	4.97	948	5.52	993	6.09

CFM	Available External Static Pressure (in. wg)									
	1.2		1.4		1.6		1.8		2.0	
	RPM	BHP	RPM	BHP	RPM	BHP	RPM	BHP	RPM	BHP
5250	876	3.08	932	3.56	986	4.07	1038	4.60	<b>1088</b>	<b>5.15</b>
5700	892	3.40	946	3.90	998	4.42	1049	4.96	<b>1097</b>	<b>5.52</b>
6100	907	3.72	960	4.23	1011	4.76	1060	5.31	<b>1107</b>	<b>5.89</b>
6500	924	4.07	975	4.59	1025	5.13	1072	5.70	<b>1119</b>	<b>6.28</b>
7000	947	4.55	996	5.09	1044	5.65	<b>1090</b>	<b>6.23</b>	-----	-----
7500	971	5.08	1019	5.64	1064	6.22	-----	-----	-----	-----
7900	992	5.55	1038	6.13	-----	-----	-----	-----	-----	-----
8300	1013	6.06	-----	-----	-----	-----	-----	-----	-----	-----
8750	-----	-----	-----	-----	-----	-----	-----	-----	-----	-----

Std Static Motor and Drive – 622–822 RPM, Max BHP 3.3

Medium Static Motor and Drive – 713–879 RPM, Max BHP 4.9

High Static Motor and Drive – 882–1078 RPM, Max BHP 6.5

----- Outside operating range

**Boldface** – Field-supplied Drive

# FAN PERFORMANCE (cont.)

Table 15 – RGH240, 20 TON VERTICAL SUPPLY / RETURN

CFM	Available External Static Pressure (in. wg)									
	0.2		0.4		0.6		0.8		1.0	
	RPM	BHP	RPM	BHP	RPM	BHP	RPM	BHP	RPM	BHP
6000	<b>605</b>	<b>1.48</b>	<b>674</b>	<b>1.77</b>	738	2.08	798	2.41	854	2.74
6500	<b>644</b>	<b>1.82</b>	709	2.14	770	2.47	827	2.81	881	3.17
7000	<b>683</b>	<b>2.22</b>	744	2.56	802	2.91	857	3.28	908	3.65
7500	722	2.68	781	3.04	836	3.41	888	3.80	938	4.19
8000	762	3.20	818	3.58	870	3.97	920	4.38	968	4.79
8500	803	3.78	855	4.19	905	4.60	953	5.02	999	5.46
9000	843	4.43	893	4.86	941	5.30	987	5.74	1032	6.19
9500	884	5.15	932	5.61	978	6.06	1022	6.53	1065	7.01
10000	925	5.95	970	6.43	1015	6.91	1057	7.40	1098	7.89

CFM	Available External Static Pressure (in. wg)									
	1.2		1.4		1.6		1.8		2.0	
	RPM	BHP	RPM	BHP	RPM	BHP	RPM	BHP	RPM	BHP
6000	907	3.10	958	3.46	1006	3.84	1052	4.23	1097	4.63
6500	932	3.54	981	3.92	1027	4.31	1073	4.72	1116	5.14
7000	958	4.04	1005	4.43	1051	4.84	1094	5.27	1137	5.70
7500	985	4.59	1031	5.01	1075	5.44	1118	5.87	1159	6.32
8000	1014	5.21	1058	5.65	1101	6.09	1142	6.55	-----	-----
8500	1044	5.90	1087	6.35	1128	6.82	1168	7.29	-----	-----
9000	1075	6.66	1116	7.13	1156	7.61	-----	-----	-----	-----
9500	1106	7.49	1146	7.98	-----	-----	-----	-----	-----	-----
10000	1139	8.40	-----	-----	-----	-----	-----	-----	-----	-----

Std Static Motor and Drive – 690–863 RPM, Max BHP 4.9

Medium Static Motor and Drive – 835–1021 RPM, Max BHP 6.5

High Static Motor and Drive – 941–1176 RPM, Max BHP 8.7

----- Outside operating range

**Boldface** – Field-supplied Drive

Table 16 – RGH300, 25 TON VERTICAL SUPPLY / RETURN

CFM	Available External Static Pressure (in. wg)									
	0.2		0.4		0.6		0.8		1.0	
	RPM	BHP	RPM	BHP	RPM	BHP	RPM	BHP	RPM	BHP
7500	<b>713</b>	<b>2.25</b>	778	2.61	838	2.97	894	3.36	946	3.76
8000	752	2.68	814	3.06	871	3.44	925	3.85	976	4.26
8500	791	3.17	850	3.56	905	3.97	957	4.39	1006	4.83
9000	831	3.71	887	4.12	939	4.55	989	4.99	1037	5.45
9500	870	4.31	924	4.75	974	5.19	1023	5.66	1069	6.13
10000	910	4.83	961	5.43	1010	5.90	1057	6.38	1102	6.87
10500	950	5.70	999	6.18	1046	6.67	1091	7.17	1135	7.69
11000	990	6.50	1037	7.01	1083	7.52	1126	8.04	1168	8.57
11500	1030	7.38	1076	7.90	1119	8.43	-----	-----	-----	-----
12000	1070	8.33	-----	-----	-----	-----	-----	-----	-----	-----
12500	-----	-----	-----	-----	-----	-----	-----	-----	-----	-----

CFM	Available External Static Pressure (in. wg)									
	1.2		1.4		1.6		1.8		2.0	
	RPM	BHP	RPM	BHP	RPM	BHP	RPM	BHP	RPM	BHP
7500	996	4.17	1044	4.60	1089	5.05	1133	5.51	1175	5.98
8000	1024	4.70	1071	5.14	1115	5.60	1158	6.07	-----	-----
8500	1053	5.27	1098	5.74	1141	6.21	-----	-----	-----	-----
9000	1083	5.91	1127	6.39	1169	6.88	-----	-----	-----	-----
9500	1113	6.61	1156	7.11	-----	-----	-----	-----	-----	-----
10000	1145	7.38	-----	-----	-----	-----	-----	-----	-----	-----
10500	-----	-----	-----	-----	-----	-----	-----	-----	-----	-----
11000	-----	-----	-----	-----	-----	-----	-----	-----	-----	-----
11500	-----	-----	-----	-----	-----	-----	-----	-----	-----	-----
12000	-----	-----	-----	-----	-----	-----	-----	-----	-----	-----
12500	-----	-----	-----	-----	-----	-----	-----	-----	-----	-----

Std Static Motor and Drive – 717–911 RPM, Max BHP 4.9

Medium Static Motor and Drive – 913–1116 RPM, Max BHP 6.5

High Static Motor and Drive – 941–1176 RPM, Max BHP 8.7

----- Outside operating range

**Boldface** – Field-supplied Drive

# FAN PERFORMANCE (cont.)

Table 17 – RGH183, 15 TON HORIZONTAL SUPPLY / RETURN

CFM	Available External Static Pressure (in. wg)									
	0.2		0.4		0.6		0.8		1.0	
	RPM	BHP	RPM	BHP	RPM	BHP	RPM	BHP	RPM	BHP
4500	523	1.13	593	1.56	656	2.03	713	2.55	766	3.10
4900	557	1.38	623	1.84	683	2.33	738	2.87	<b>790</b>	<b>3.44</b>
5250	587	1.62	650	2.11	708	2.63	761	3.18	811	3.77
5600	617	1.90	678	2.41	733	2.95	<b>785</b>	<b>3.53</b>	833	4.14
6000	652	2.25	710	2.80	<b>763</b>	<b>3.37</b>	813	3.97	860	4.60
6400	688	2.65	743	3.24	794	3.84	841	4.46	-----	-----
6750	719	3.04	<b>772</b>	<b>3.66</b>	821	4.29	-----	-----	-----	-----
7100	<b>750</b>	<b>3.47</b>	802	4.12	849	4.78	-----	-----	-----	-----
7500	786	4.01	836	4.70	-----	-----	-----	-----	-----	-----

CFM	Available External Static Pressure (in. wg)									
	1.2		1.4		1.6		1.8		2.0	
	RPM	BHP	RPM	BHP	RPM	BHP	RPM	BHP	RPM	BHP
4500	814	3.68	859	4.27	901	4.88	-----	-----	-----	-----
4900	837	4.05	882	4.67	-----	-----	-----	-----	-----	-----
5250	858	4.40	-----	-----	-----	-----	-----	-----	-----	-----
5600	879	4.78	-----	-----	-----	-----	-----	-----	-----	-----
6000	-----	-----	-----	-----	-----	-----	-----	-----	-----	-----
6400	-----	-----	-----	-----	-----	-----	-----	-----	-----	-----
6750	-----	-----	-----	-----	-----	-----	-----	-----	-----	-----
7100	-----	-----	-----	-----	-----	-----	-----	-----	-----	-----
7500	-----	-----	-----	-----	-----	-----	-----	-----	-----	-----

Std Static Motor and Drive – 514–680 RPM, Max BHP 2.2

Medium Static Motor and Drive – 614–780 RPM, Max BHP 3.3

High Static Motor and Drive – 746–912 RPM, Max BHP 4.9

----- Outside operating range

**Boldface** – Field-supplied Drive

Table 18 – RGH213, 17.5 TON HORIZONTAL SUPPLY / RETURN

CFM	Available External Static Pressure (in. wg)									
	0.2		0.4		0.6		0.8		1.0	
	RPM	BHP	RPM	BHP	RPM	BHP	RPM	BHP	RPM	BHP
5250	<b>587</b>	<b>1.62</b>	650	2.11	708	2.63	761	3.18	811	3.77
5700	626	1.98	686	2.51	740	3.05	791	3.63	840	4.25
6100	661	2.35	718	2.91	771	3.48	820	4.09	866	4.73
6500	696	2.76	751	3.36	802	3.96	849	4.59	<b>894</b>	<b>5.25</b>
7000	741	3.34	793	3.99	841	4.63	<b>886</b>	<b>5.30</b>	929	5.99
7500	786	4.01	836	4.70	<b>882</b>	<b>5.39</b>	925	6.09	-----	-----
7900	823	4.60	<b>871</b>	<b>5.34</b>	915	6.06	-----	-----	-----	-----
8300	<b>860</b>	<b>5.26</b>	906	6.03	-----	-----	-----	-----	-----	-----
8750	901	6.06	-----	-----	-----	-----	-----	-----	-----	-----

CFM	Available External Static Pressure (in. wg)									
	1.2		1.4		1.6		1.8		2.0	
	RPM	BHP	RPM	BHP	RPM	BHP	RPM	BHP	RPM	BHP
5250	858	4.40	902	5.05	943	5.72	<b>983</b>	<b>6.41</b>	-----	-----
5700	885	4.90	928	5.58	969	6.28	-----	-----	-----	-----
6100	911	5.40	953	6.10	-----	-----	-----	-----	-----	-----
6500	937	5.94	-----	-----	-----	-----	-----	-----	-----	-----
7000	-----	-----	-----	-----	-----	-----	-----	-----	-----	-----
7500	-----	-----	-----	-----	-----	-----	-----	-----	-----	-----
7900	-----	-----	-----	-----	-----	-----	-----	-----	-----	-----
8300	-----	-----	-----	-----	-----	-----	-----	-----	-----	-----
8750	-----	-----	-----	-----	-----	-----	-----	-----	-----	-----

Std Static Motor and Drive – 622–822 RPM, Max BHP 3.3

Medium Static Motor and Drive – 713–879 RPM, Max BHP 4.9

High Static Motor and Drive – 882–1078 RPM, Max BHP 6.5

----- Outside operating range

**Boldface** – Field-supplied Drive

# FAN PERFORMANCE (cont.)

Table 19 – RGH243, 20 TON HORIZONTAL SUPPLY / RETURN

CFM	Available External Static Pressure (in. wg)									
	0.2		0.4		0.6		0.8		1.0	
	RPM	BHP	RPM	BHP	RPM	BHP	RPM	BHP	RPM	BHP
6000	<b>651</b>	<b>2.25</b>	709	2.78	762	3.35	812	3.96	858	4.60
6500	696	2.77	750	3.33	801	3.94	848	4.57	893	5.24
7000	741	3.37	792	3.96	840	4.60	886	5.27	929	5.97
7500	787	4.05	834	4.67	880	5.34	924	6.05	965	6.78
8000	833	4.83	878	5.48	921	6.18	963	6.92	1003	7.69
8500	879	5.70	922	6.39	963	7.13	1003	7.89	1042	8.69
9000	<b>926</b>	<b>6.69</b>	966	7.41	1006	8.17	-----	-----	-----	-----
9500	973	7.78	1011	8.54	-----	-----	-----	-----	-----	-----
10000	-----	-----	-----	-----	-----	-----	-----	-----	-----	-----

CFM	Available External Static Pressure (in. wg)									
	1.2		1.4		1.6		1.8		2.0	
	RPM	BHP	RPM	BHP	RPM	BHP	RPM	BHP	RPM	BHP
6000	902	5.25	943	5.93	983	6.62	1021	7.32	1057	8.04
6500	935	5.94	976	6.65	1014	7.38	1051	8.12	1086	8.88
7000	970	6.70	1009	7.44	1046	8.21	-----	-----	-----	-----
7500	1005	7.54	1043	8.32	-----	-----	-----	-----	-----	-----
8000	1042	8.48	-----	-----	-----	-----	-----	-----	-----	-----
8500	-----	-----	-----	-----	-----	-----	-----	-----	-----	-----
9000	-----	-----	-----	-----	-----	-----	-----	-----	-----	-----
9500	-----	-----	-----	-----	-----	-----	-----	-----	-----	-----
10000	-----	-----	-----	-----	-----	-----	-----	-----	-----	-----

Std Static Motor and Drive – 690–863 RPM, Max BHP 4.9

Medium Static Motor and Drive – 835–1021 RPM, Max BHP 6.5

High Static Motor and Drive – 941–1176 RPM, Max BHP 8.7

----- Outside operating range

**Boldface** – Field-supplied Drive

Table 20 – RGH303, 25 TON HORIZONTAL SUPPLY / RETURN

CFM	Available External Static Pressure (in. wg)									
	0.2		0.4		0.6		0.8		1.0	
	RPM	BHP	RPM	BHP	RPM	BHP	RPM	BHP	RPM	BHP
7500	715	3.12	767	3.68	815	4.28	862	4.90	906	5.58
8000	751	3.65	800	4.25	847	4.87	892	5.53	934	6.21
8500	786	4.24	834	4.86	879	5.51	922	6.19	963	6.90
9000	822	4.88	867	5.53	910	6.21	952	6.91	991	7.64
9500	856	5.57	916	6.25	941	6.95	981	7.68	<b>1020</b>	<b>8.44</b>
10000	890	6.33	932	7.03	973	7.76	<b>1011</b>	<b>8.52</b>	-----	-----
10500	924	7.14	965	7.87	1004	8.62	-----	-----	-----	-----
11000	958	8.01	997	8.70	-----	-----	-----	-----	-----	-----
11500	991	8.94	1029	9.73	-----	-----	-----	-----	-----	-----

CFM	Available External Static Pressure (in. wg)									
	1.2		1.4		1.6		1.8		2.0	
	RPM	BHP	RPM	BHP	RPM	BHP	RPM	BHP	RPM	BHP
7500	948	6.27	988	6.98	1027	7.72	1065	8.49	-----	-----
8000	975	6.93	1014	7.67	1052	8.43	-----	-----	-----	-----
8500	1002	7.64	1041	8.40	-----	-----	-----	-----	-----	-----
9000	<b>1030</b>	<b>8.41</b>	-----	-----	-----	-----	-----	-----	-----	-----
9500	-----	-----	-----	-----	-----	-----	-----	-----	-----	-----
10000	-----	-----	-----	-----	-----	-----	-----	-----	-----	-----
10500	-----	-----	-----	-----	-----	-----	-----	-----	-----	-----
11000	-----	-----	-----	-----	-----	-----	-----	-----	-----	-----
11500	-----	-----	-----	-----	-----	-----	-----	-----	-----	-----

Std Static Motor and Drive – 647–791 RPM, Max BHP 4.9

Medium Static Motor and Drive – 755–923 RPM, Max BHP 6.5

High Static Motor and Drive – 827–1010 RPM, Max BHP 8.7

----- Outside operating range

**Boldface** – Field-supplied Drive



# FAN PERFORMANCE (cont.)

Table 21 – PULLEY ADJUSTMENT

Unit RGH	MOTOR/DRIVE COMBO	MOTOR PULLEY TURNS OPEN										
		0	0.5	1	1.5	2	2.5	3	3.5	4	4.5	5
181 – 183	Standard Static	680	663	647	630	614	597	580	564	547	531	514
	Medium Static	863	845	826	808	789	771	753	734	716	697	679
	High Static	1009	991	972	954	936	918	899	881	863	844	826
210 – 213	Standard Static	822	802	782	762	742	722	702	682	662	642	622
	Medium Static	879	862	846	829	813	796	779	763	746	730	713
	High Static	1078	1058	1039	1019	1000	980	960	941	921	902	882
240 – 243	Standard Static	863	846	828	811	794	777	759	742	725	707	690
	Medium Static	1021	1002	984	965	947	928	909	891	872	854	835
	High Static	1176	1153	1129	1106	1082	1059	1035	1012	988	965	941
300 – 303	Standard Static	911	892	872	853	833	814	795	775	756	736	717
	Medium Static	1116	1096	1075	1055	1035	1015	994	974	954	933	913
	High Static	1176	1153	1129	1106	1082	1059	1035	1012	988	965	941

**NOTE:** Do not adjust pulley further than 5 turns open.

■ – Factory settings

# DAMPER, BAROMETRIC RELIEF, AND PERFORMANCE, 15 to 25 Ton

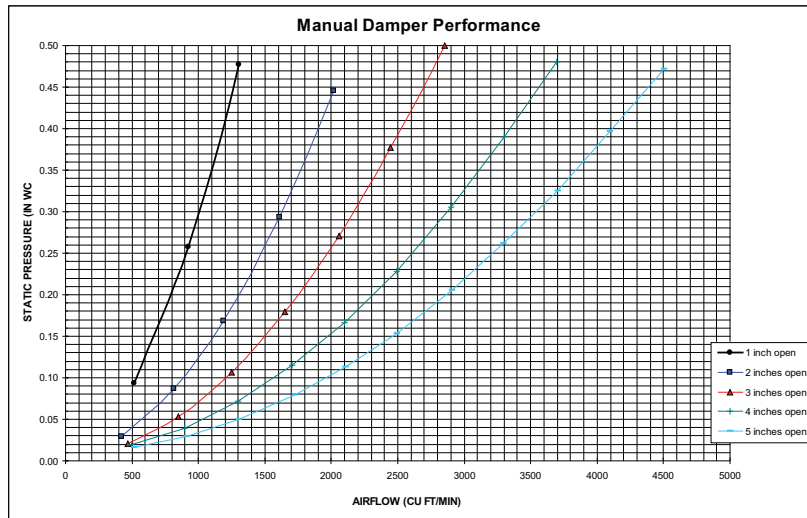

**Fig 1 – Manual Damper Performance**

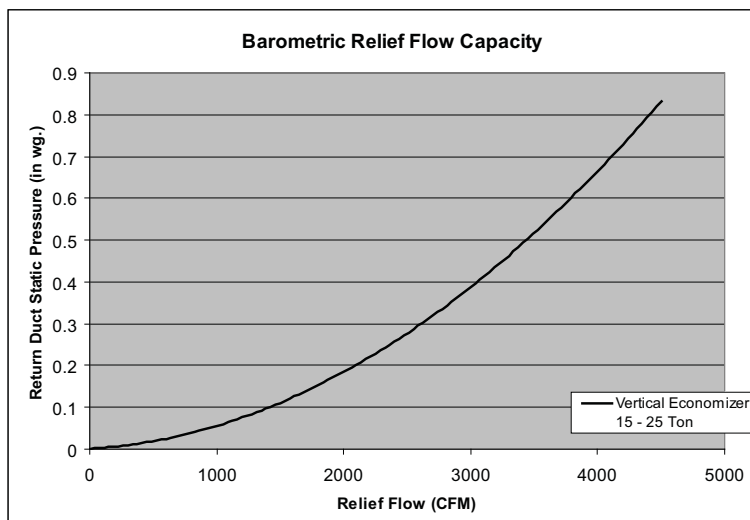

**Fig 2 – Barometric Relief Flow Capacity**

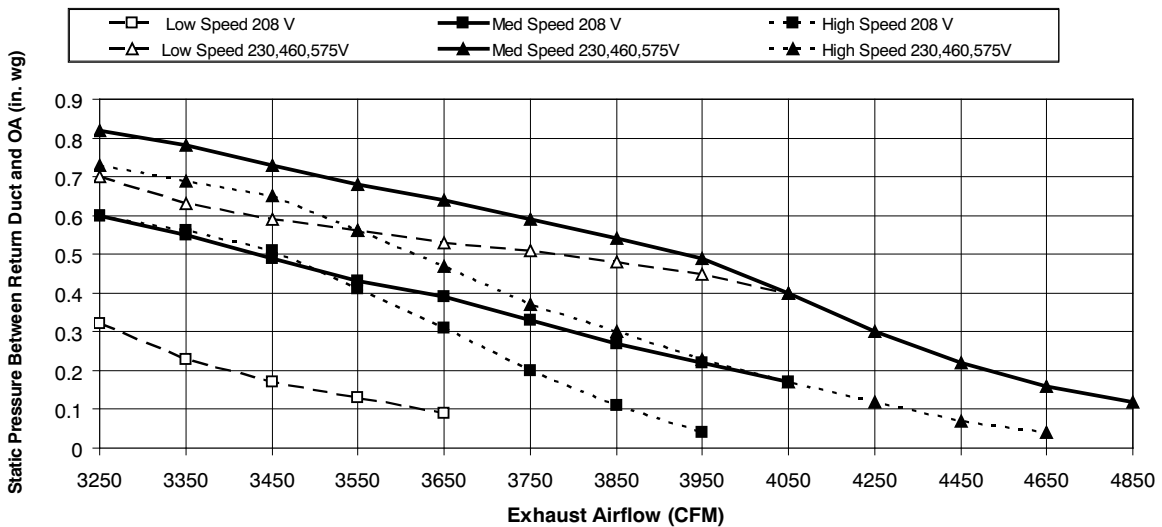

**Fig 3 – Power Exhaust Fan Performance**

# ELECTRICAL INFORMATION

## Table 22 – 2 Stage Cooling

Unit RGH	V-Ph-Hz	Voltage Range		Comp 1		Comp 2		OFM (ea)		IFM		
		MIN	MAX	RLA	LRA	RLA	LRA	WATTS	FLA	TYPE	Full Load Efficiency	FLA
181/183	208-3-60	187	253	29.5	195	30.1	225	350	1.5	STD	81.3%	7.5
										MED	83.8%	10.2
										HIGH	83.6%	15.0
	230-3-60	187	253	29.5	195	30.1	225	350	1.5	STD	81.3%	7.5
										MED	83.8%	10.2
										HIGH	83.6%	15.0
	460-3-60	414	506	14.7	95	16.7	114	277	0.9	STD	81.3%	3.4
										MED	83.8%	4.8
										HIGH	83.6%	7.4
	575-3-60	518	633	12.2	80	12.2	80	397	0.6	STD	81.1%	2.8
										MED	81.1%	2.8
										HIGH	83.6%	5.6
210/213	208-3-60	187	253	29.5	195	30.1	225	350	1.5	STD	83.8%	10.2
										MED	83.6%	15.0
										HIGH	87.5%	12.8
										HIGH-High Eff	89.5%	20.4
	230-3-60	187	253	29.5	195	30.1	225	350	1.5	STD	83.8%	10.2
										MED	83.6%	15.0
										HIGH	87.5%	12.8
										HIGH-High Eff	89.5%	20.4
	460-3-60	414	506	14.7	95	16.7	114	277	0.9	STD	83.8%	4.8
										MED	83.6%	7.4
										HIGH	87.5%	6.4
										HIGH-High Eff	89.5%	20.4
575-3-60	518	633	12.2	80	12.2	80	397	0.6	STD	81.1%	2.8	
									MED	83.6%	5.6	
									HIGH	87.5%	5.1	
									HIGH-High Eff	89.5%	9.0	
240/243	208-3-60	187	253	48.1	245	29.5	195	350	1.5	STD	83.6%	15.0
										MED	87.5%	12.8
										HIGH	88.5%	19.4
										MED-High Eff	89.5%	20.4
										HIGH-High Eff	91.7%	33.1
	230-3-60	187	253	48.1	245	29.5	195	350	1.5	STD	83.6%	15.0
										MED	87.5%	12.8
										HIGH	88.5%	19.4
										MED-High Eff	89.5%	20.4
										HIGH-High Eff	91.7%	33.1
	460-3-60	414	506	18.6	125	14.7	95	277	0.9	STD	83.6%	7.4
										MED	87.5%	6.4
HIGH										88.5%	9.7	
MED-High Eff										89.5%	20.4	
HIGH-High Eff										91.7%	33.1	
575-3-60	518	633	14.7	100	12.2	80	397	0.6	STD	83.6%	5.6	
									MED	87.5%	5.1	
									HIGH	88.5%	7.8	
									MED-High Eff	89.5%	9.0	
									HIGH-High Eff	91.7%	9.5	

# ELECTRICAL INFORMATION

**Table 22 – 2 Stage Cooling (Cont.)**

Unit RGH	V-Ph-Hz	Voltage Range		Comp 1		Comp 2		OFM (ea)		IFM		
		MIN	MAX	RLA	LRA	RLA	LRA	WATTS	FLA	TYPE	Full Load Efficiency	FLA
300/303	208-3-60	187	253	48.1	245	48.1	245	350	1.5	STD	83.6%	15.0
										MED	87.5%	12.8
										HIGH	88.5%	19.4
										MED-High Eff	89.5%	20.4
	HIGH-High Eff	91.7%	33.1									
	230-3-60	187	253	48.1	245	48.1	245	350	1.5	STD	83.6%	15.0
										MED	87.5%	12.8
										HIGH	88.5%	19.4
										MED-High Eff	89.5%	20.4
	HIGH-High Eff	91.7%	33.1									
	460-3-60	414	506	18.6	125	18.6	125	277	0.9	STD	83.6%	7.4
										MED	87.5%	6.4
										HIGH	88.5%	9.7
										MED-High Eff	89.5%	20.4
	HIGH-High Eff	91.7%	33.1									
	575-3-60	518	633	14.7	100	14.7	100	397	0.6	STD	83.6%	5.6
MED										87.5%	5.1	
HIGH										88.5%	7.8	
MED-High Eff										89.5%	9.0	
HIGH-High Eff	91.7%	9.5										

**Table 23 – MCA/MOCP DETERMINATION NO C.O. OR UNPWRD C.O.**

UNIT RGH	NOM. V-Ph-Hz	IFM TYPE	Combustion Fan Motor FLA	Power Exhaust FLA	NO C.O. or UNPWR C.O.							
					NO P.E.				w/ P.E. (pwrd fr/ unit)			
					MCA	MOCP	DISC. SIZE		MCA	MOCP	DISC. SIZE	
							FLA	LRA			FLA	LRA
181/183	208/230-3-60	STD	0.52	5.9	68.3	90.0	71	393	80.1	100.0	85	413
		MED			71.0	90.0	74	410	82.8	100.0	88	430
		HIGH			75.8	100.0	80	419	87.6	100.0	93	439
	460-3-60	STD	0.3	3.1	34.9	45.0	36	234	41.1	50.0	44	246
		MED			36.3	45.0	38	243	42.5	50.0	45	255
		HIGH			38.9	50.0	41	247	45.1	50.0	48	259
	575-3-60	STD	0.24	2.4	26.2	30.0	27	184	31.0	40.0	33	192
		MED			26.2	30.0	27	184	31.0	40.0	33	192
		HIGH			29.0	35.0	31	198	33.8	40.0	36	206
210/213	208/230-3-60	STD	0.52	5.9	75.7	100.0	79	440	87.5	100.0	93	460
		MED			80.5	100.0	85	449	92.3	100.0	98	469
		HIGH			78.3	100.0	82	451	90.1	100.0	96	471
		HIGH-Hi Eff			85.9	100.0	91	459	97.7	125.0	104	479
	460-3-60	STD	0.3	3.1	36.6	45.0	38	245	42.8	50.0	46	257
		MED			39.2	50.0	41	249	45.4	50.0	49	261
		HIGH			38.2	50.0	40	250	44.4	50.0	47	262
		HIGH-Hi Eff			42.0	50.0	45	254	48.2	60.0	52	266
	575-3-60	STD	0.24	2.4	26.2	30.0	27	186	31.0	40.0	33	194
		MED			29.0	35.0	31	200	33.8	40.0	36	208
		HIGH			28.5	35.0	30	189	33.3	40.0	36	197
		HIGH-Hi Eff			32.4	40.0	35	198	37.2	45.0	40	206
240/243	208/230-3-60	STD	0.52	5.9	88.7	100.0	93	544	100.5	125.0	107	564
		MED			86.5	100.0	91	546	98.3	125.0	104	566
		HIGH			93.1	110.0	98	582	104.9	125.0	112	602
		MED-Hi Eff			94.1	110.0	100	554	105.9	125.0	113	574
		HIGH-Hi Eff			107.6	125.0	114	628	119.4	150.0	128	648
	460-3-60	STD	0.3	3.1	48.6	60.0	51	277	54.8	60.0	58	289
		MED			47.6	60.0	50	278	53.8	60.0	57	290
		HIGH			50.9	60.0	54	296	57.1	70.0	61	308
		MED-Hi Eff			51.4	60.0	54	282	57.6	70.0	61	294
		HIGH-Hi Eff			57.4	70.0	61	319	63.6	80.0	68	331
	575-3-60	STD	0.24	2.4	35.5	45.0	37	204	40.3	50.0	43	212
		MED			35.0	45.0	37	193	39.8	50.0	42	201
		HIGH			37.7	45.0	40	219	42.5	50.0	45	227
		MED-Hi Eff			38.9	50.0	41	202	43.7	50.0	47	210
		HIGH-Hi Eff			39.4	50.0	42	229	44.2	50.0	47	237
	300/303	208/230-3-60	STD	0.52	5.9	117.4	150.0	121	584	129.2	175.0	135
MED			115.2			150.0	119	586	127.0	175.0	132	606
HIGH			121.8			150.0	126	622	133.6	175.0	140	642
MED-Hi Eff			122.8			150.0	127	594	134.6	175.0	141	614
HIGH-Hi Eff			135.5			175.0	142	668	147.3	175.0	156	688
460-3-60		STD	0.3	3.1	54.0	60.0	57	303	60.2	70.0	64	315
		MED			53.0	60.0	56	304	59.2	70.0	63	316
		HIGH			56.3	70.0	59	322	62.5	80.0	66	334
		MED-Hi Eff			56.8	70.0	60	308	63.0	80.0	67	320
		HIGH-Hi Eff			62.8	80.0	67	345	69.0	80.0	74	357
575-3-60		STD	0.24	2.4	40.4	50.0	42	228	45.2	50.0	48	236
		MED			39.9	50.0	42	217	44.7	50.0	47	225
		HIGH			42.6	50.0	45	243	47.4	60.0	50	251
	MED-Hi Eff	43.8			50.0	46	226	48.6	60.0	52	234	
		HIGH-Hi Eff			44.3	50.0	47	253	49.1	60.0	52	261

See Legend on next page

**LEGEND:**

- C.O. – Convenient outlet
- DISC – Disconnect
- FLA – Full load amps
- IFM – Indoor fan motor
- LRA – Locked rotor amps
- MCA – Minimum circuit amps
- MOCP – Maximum over current protection
- P.E. – Power exhaust
- UNPWRD CO – Unpowered convenient outlet



**NOTES:**

1. In compliance with NEC requirements for multimotor and combination load equipment (refer to NEC Articles 430 and 440), the overcurrent protective device for the unit shall be fuse or HACR breaker. Canadian units may be fuse or circuit breaker.

**2. Unbalanced 3-Phase Supply Voltage**

Never operate a motor where a phase imbalance in supply voltage is greater than 2%. Use the following formula to determine the percentage of voltage imbalance.

$$\% \text{ Voltage Imbalance} = 100 \times \frac{\text{max voltage deviation from average voltage}}{\text{average voltage}}$$

Example: Supply voltage is 230-3-60



- AB = 224 v
- BC = 231 v
- AC = 226 v

$$\begin{aligned} \text{Average Voltage} &= \frac{(224 + 231 + 226)}{3} = \frac{681}{3} \\ &= 227 \end{aligned}$$

Determine maximum deviation from average voltage.

(AB)  $227 - 224 = 3 \text{ v}$

(BC)  $231 - 227 = 4 \text{ v}$

(AC)  $227 - 226 = 1 \text{ v}$

Maximum deviation is 4 v.

Determine percent of voltage imbalance.

$$\begin{aligned} \% \text{ Voltage Imbalance} &= 100 \times \frac{4}{227} \\ &= 1.76\% \end{aligned}$$

This amount of phase imbalance is satisfactory as it is below the maximum allowable 2%.

**IMPORTANT:** If the supply voltage phase imbalance is more than 2%, contact your local electric utility company immediately.

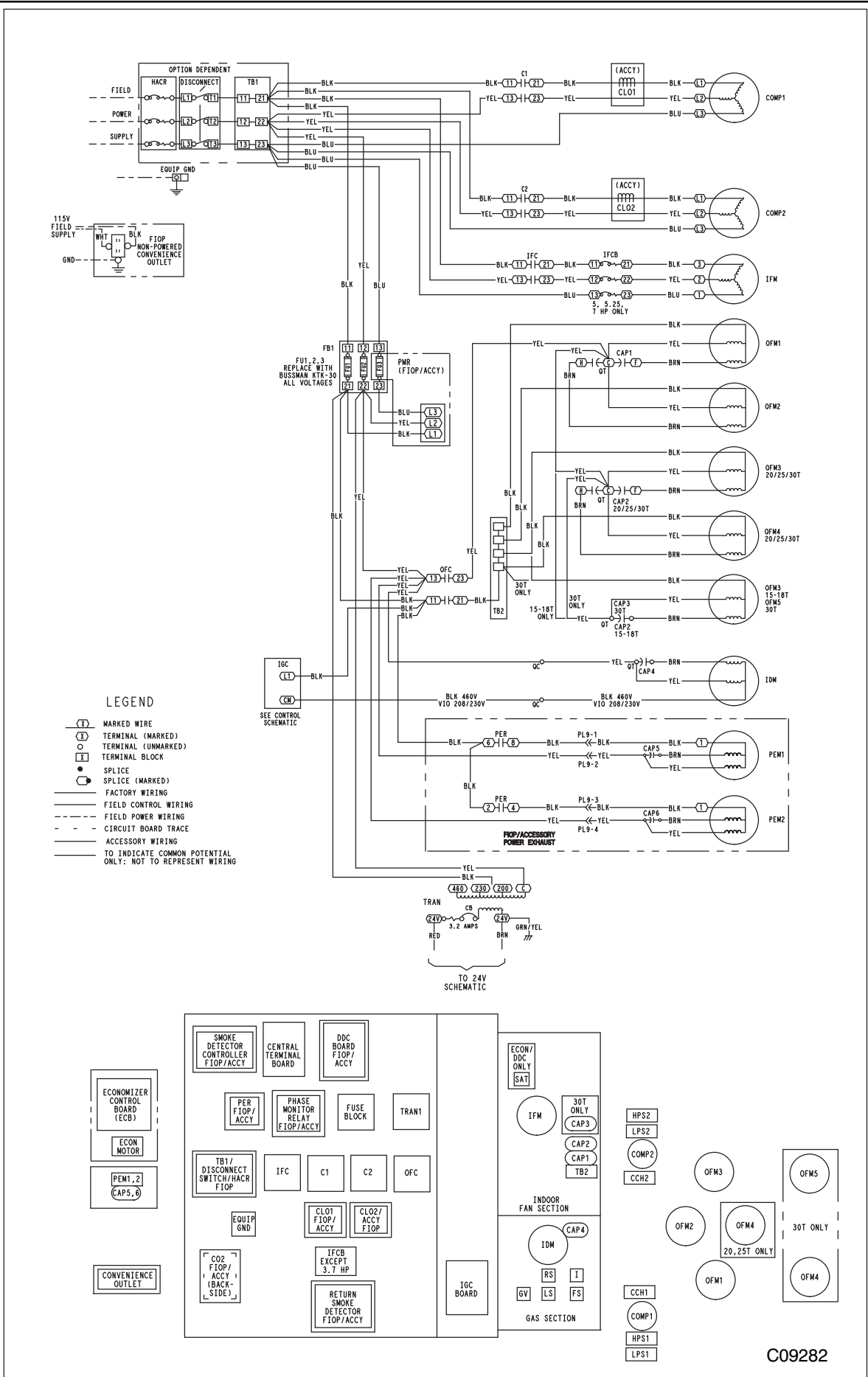

Fig. 4 Typical Power Diagram (All Voltages)

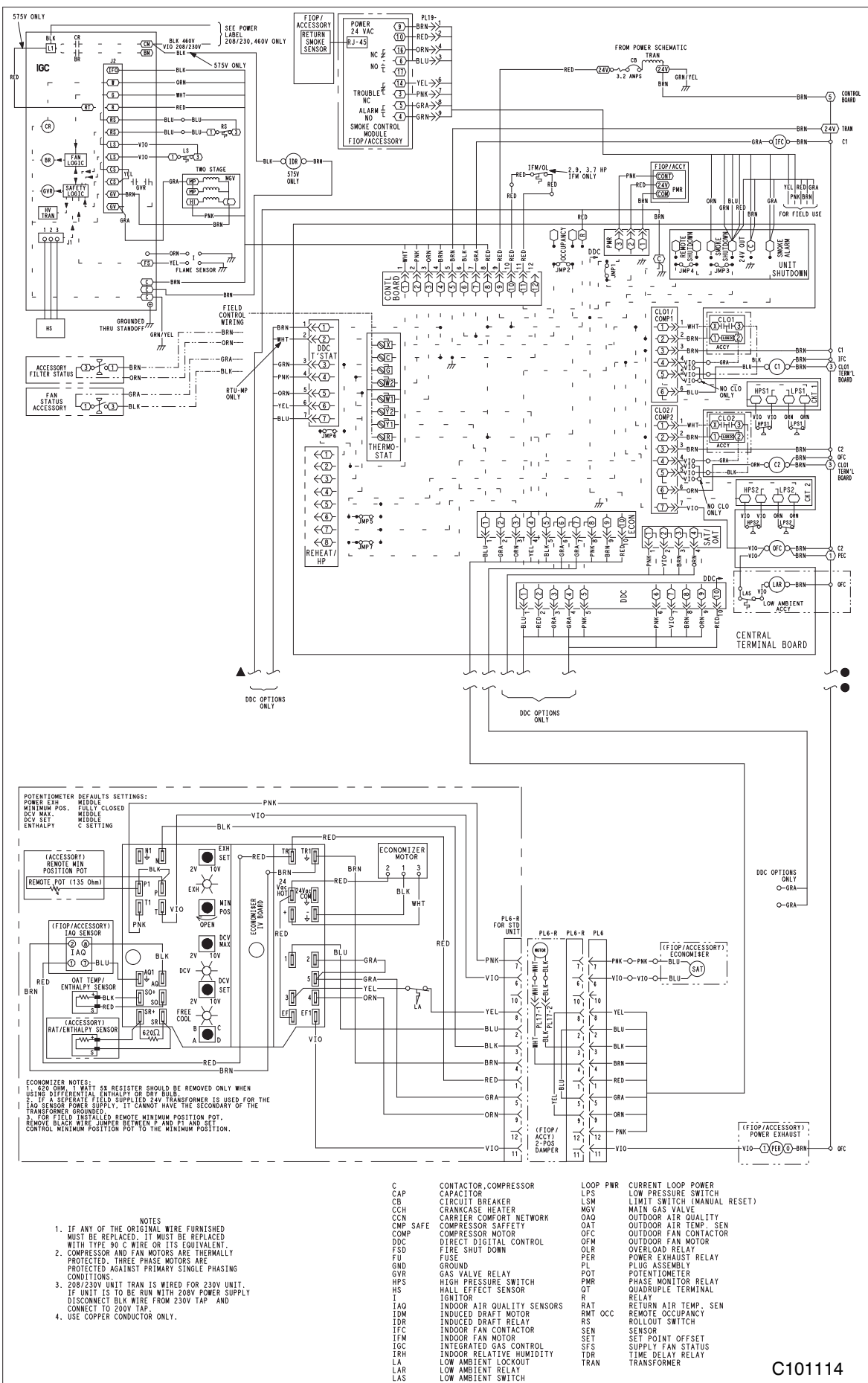

Fig. 5 Typical Control Diagram (All Voltages)



# SEQUENCE OF OPERATION

## General

The sequence below describes the sequence of operation for an electro-mechanical unit with and without a factory installed "economizer". For information regarding a direct digital controller, see the start-up, operations, and troubleshooting manual for the applicable controller.

### Units with no economizer

#### Cooling —

When the field supplied commercial grade thermostat calls for cooling, terminals G and Y1 are energized. As a result, the indoor-fan contactor (IFC) and the compressor contactor (C1) are energized, causing the indoor-fan motor (IFM), compressor #1, and outdoor fan to start. If the unit has 2 stages of cooling, the thermostat will additionally energize Y2. The Y2 signal will energize compressor contactor #2 (C2), causing compressor #2 to start. Regardless of the number of stages, the outdoor-fan motor runs continuously while unit is cooling.

#### Heating —

**NOTE:** Units have 2 stages of gas heat.

When the field supplied commercial grade thermostat calls for heating, power is sent to W on the Integrated Gas Controller (IGC) board. An LED (light-emitting diode) on the IGC board turns on and remains on during normal operation. A check is made to ensure that the rollout switch and limit switch are closed. If the check was successful, the induced-draft motor is energized, and when its speed is satisfactory, as proven by the "hall effect" sensor, the ignition activation period begins. The burners will ignite within 5 seconds. If the burners do not light, there is a 22-second delay before another 5-second attempt. This sequence is repeated for 15 minutes or until the burners light. If, after the 15 minutes, the burners still have not lit, heating is locked out. To reset the control, break 24-v power to the thermostat.

When ignition occurs, the IGC board will continue to monitor the condition of the rollout switch, the limit switches, the "hall effect" sensor, as well as the flame sensor. 45 seconds after ignition occurs, assuming the unit is controlled through a room thermostat set for fan auto, the indoor-fan motor will energize (and the outdoor-air dampers will open to their minimum position). If, for some reason, the over-temperature limit opens prior to the start of the indoor fan blower, the unit will shorten the 45-second delay to 5 seconds less than the time from initiation of heat to when the limit tripped. Gas will not be interrupted to the burners and heating will continue. Once the fan-on delay has been modified, it will not change back to 45 seconds until power is reset to the control.

On units with 2 stages of heat, when additional heat is required, W2 closes and initiates power to the second stage of the main gas valve. When the thermostat is satisfied, W1 and W2 open and the gas valve closes, interrupting the flow of gas to the main burners.

If the call for W1 lasted less than 1 minute, the heating cycle will not terminate until 1 minute after W1 became active. If the unit is controlled through a room thermostat set for fan auto, the indoor-fan motor will continue to operate for an additional 45 seconds then stop. If the over-temperature limit opens after the indoor motor is stopped, but within 10 minutes of W1 becoming inactive, on the next cycle the time will be extended by 15 seconds. The maximum delay is 3 minutes. Once modified, the fan off delay will not change back to 45 seconds unless power is reset to the control. A LED indicator is provided on the IGC to monitor operation.

### Units with an Economizer

#### Cooling —

When free cooling is not available, the compressors will be controlled by the zone thermostat. When free cooling is available, the outdoor-air damper is modulated by the economizer control to provide a 50°F (10°C) to 55°F (13°C) mixed-air temperature into the zone. As the mixed air temperature fluctuates above 55°F (13°C) or below 50°F (10°C) dampers will be modulated (open or close) to bring the mixed-air temperature back within control. If mechanical cooling is utilized with free cooling, the outdoor-air damper will maintain its current position at the time the compressor is started. If the increase in cooling capacity causes the mixed-air temperature to drop below 45°F (7°C), then the outdoor-air damper position will be decreased to the minimum position. If the mixed-air temperature continues to fall, the outdoor-air damper will close. Control returns to normal once the mixed-air temperature rises above 48°F (9°C). The power exhaust fans will be energized and de-energized, if installed, as the outdoor-air damper opens and closes.

If field-installed accessory CO<sub>2</sub> sensors are connected to the economizer control, a demand controlled ventilation strategy will begin to operate. As the CO<sub>2</sub> level in the zone increases above the CO<sub>2</sub> setpoint, the minimum position of the damper will be increased proportionally. As the CO<sub>2</sub> level decreases because of the increase in fresh air, the outdoor-air damper will be proportionally closed. For economizer operation, there must be a thermostat call for the fan (G). If the unit is occupied and the fan is on, the damper will operate at minimum position. Otherwise, the damper will be closed.

When the economizer control is in the occupied mode and a call for cooling exists (Y1 on the thermostat), the control will first check for indoor fan operation. If the fan is not on, then cooling will not be activated. If the fan is on, then the control will open the economizer damper to the minimum position.

On the initial power to the economizer control, it will take the damper up to 2 1/2 minutes before it begins to position itself. After the initial power-up, further changes in damper position can take up to 30 seconds to initiate. Damper movement from full closed to full open (or vice versa) will take between 1 1/2 and 2 1/2 minutes. If free cooling can be used as determined from the appropriate changeover command (switch, dry bulb, enthalpy curve, differential dry bulb, or differential enthalpy), then the control will modulate the dampers open to maintain the mixed-air temperature setpoint at 50°F (10°C) to 55°F (13°C). If there is a further demand for cooling (cooling second stage – Y2 is energized), then the control will bring on compressor stage 1 to maintain the mixed-air temperature setpoint. The economizer damper will be open at maximum position. economizer operation is limited to a single compressor.

#### Heating —

The sequence of operation for the heating is the same as a unit with no economizer. The only difference is how the economizer acts. The economizer will stay at the Economizer Minimum Position while the evaporator fan is operating. The outdoor-air damper is closed when the indoor fan is not operating.

Refer to Service and Maintenance Manual for further details.

## GAS HEAT / ELECTRIC COOLING PACKAGED ROOFTOP

### HVAC Guide Specifications

Size Range:15 to 25 Nominal Tons

<u>Section</u>	<u>Description</u>
----------------	--------------------

<b>23 06 80</b>	<b>Schedules for Decentralized HVAC Equipment</b>
-----------------	---

23 06 80.13	Decentralized Unitary HVAC Equipment Schedule
-------------	---

23 06 80.13.A.	Rooftop unit schedule
----------------	-----------------------

1. Schedule is per the project specification requirements.

<b>23 07 16</b>	<b>HVAC Equipment Insulation</b>
-----------------	----------------------------------

23 07 16.13	Decentralized, Rooftop Units:
-------------	-------------------------------

23 07 16.13.A.	Evaporator fan compartment:
----------------	-----------------------------

1. Interior cabinet surfaces shall be insulated with a minimum 1/2-in. thick, minimum 1 1/2 lb density, flexible fiberglass insulation bonded with a phenolic binder, neoprene coated on the air side.
2. Insulation and adhesive shall meet NFPA 90A requirements for flame spread and smoke generation.

23 07 16.13.B.	Gas heat compartment:
----------------	-----------------------

1. Aluminum foil-faced fiberglass insulation shall be used.
2. Insulation and adhesive shall meet NFPA 90A requirements for flame spread and smoke generation.

<b>23 09 13</b>	<b>Instrumentation and Control Devices for HVAC</b>
-----------------	---

23 09 13.23	Sensors and Transmitters
-------------	--------------------------

23 09 13.23.A.	Thermostats
----------------	-------------

1. Thermostat must
  - a. energize both "W" and "G" when calling for heat.
  - b. have capability to energize 2 different stages of cooling, and 2 different stages of heating.
  - c. include capability for occupancy scheduling.

<b>23 09 33</b>	<b>Electric and Electronic Control System for HVAC</b>
-----------------	--

23 09 33.13	Decentralized, Rooftop Units:
-------------	-------------------------------

23 09 33.13.A.	General:
----------------	----------

1. Shall be complete with self-contained low-voltage control circuit protected by a resettable circuit breaker on the 24-v transformer side. Transformer shall have 75VA capability.
2. Shall utilize color-coded wiring.
3. Shall include a central control terminal board to conveniently and safely provide connection points for vital control functions such as: smoke detectors, phase monitor, gas controller, economizer, thermostat, and low and high pressure switches.
4. The heat exchanger shall be controlled by an integrated gas controller (IGC) microprocessor. See heat exchanger section of this specification.
5. Unit shall include a minimum of one 8-pin screw terminal connection board for connection of control wiring.

23 09 33.23.B.	Safeties:
----------------	-----------

1. Compressor over-temperature, over-current. High internal pressure differential.
2. Low-pressure switch.
  - a. Units shall have different sized connectors for the circuit 1 and circuit 2 low and high pressure switches. They shall physically prevent the cross-wiring of the safety switches between circuits 1 and 2.
  - b. Low pressure switch shall use different color wire than the high pressure switch. The purpose is to assist the installer and service technician to correctly wire and or troubleshoot the rooftop unit.

3. High–pressure switch.
  - a. Units shall have different sized connectors for the circuit 1 and circuit 2 low and high pressure switches. They shall physically prevent the cross–wiring of the safety switches between circuits 1 and 2.
  - b. High pressure switch shall use different color wire than the low pressure switch. The purpose is to assist the installer and service technician to correctly wire and or troubleshoot the rooftop unit.
4. Automatic reset, motor thermal overload protector.
5. Heating section shall be provided with the following minimum protections:
  - a. High–temperature limit switches.
  - b. Induced draft motor speed sensor.
  - c. Flame rollout switch.
  - d. Flame proving controls.

### **23 09 93 Sequence of Operations for HVAC Controls**

23 09 93.13 Decentralized, Rooftop Units:

23 09 93.13 INSERT SEQUENCE OF OPERATION

### **23 40 13 Panel Air Filters**

23 40 13.13 Decentralized, Rooftop Units:

23 40 13.13.A. Standard filter section

1. Shall consist of factory–installed, low velocity, disposable 2–in. thick fiberglass filters of commercially available sizes.
2. Unit shall use only one filter size. Multiple sizes are not acceptable.
3. Filters shall be accessible through a dedicated, weather tight access panel.
4. 4–in filter capabilities shall be capable with pre–engineered and approved filter track field installed accessory. This kit requires field furnished filters.

### **23 81 19 Self–Contained Air Conditioners**

23 81 19.13 Medium–Capacity Self–Contained Air Conditioners (RGH181–303)

23 81 19.13.A. General

1. Outdoor, rooftop mounted, electrically controlled, heating and cooling unit utilizing a fully hermetic scroll compressor(s) for cooling duty and gas combustion for heating duty.
2. Factory assembled, single–piece heating and cooling rooftop unit. Contained within the unit enclosure shall be all factory wiring, piping, controls, and special features required prior to field start–up.
3. Unit shall use environmentally sound, R–410A refrigerant.
4. Unit shall be installed in accordance with the manufacturer’s instructions.
5. Unit must be selected and installed in compliance with local, state, and federal codes.

23 81 19.13.B. Quality Assurance

1. Unit meets ASHRAE 90.1 minimum efficiency requirements.
2. Units are Energy Star certified where sizes are required.
3. Unit shall be rated in accordance with AHRI Standard 340/360.
4. Unit shall be designed to conform to ASHRAE 15.
5. Unit shall be UL–tested and certified in accordance with ANSI Z21.47 Standards and UL–listed and certified under Canadian standards as a total package for safety requirements.
6. Insulation and adhesive shall meet NFPA 90A requirements for flame spread and smoke generation.
7. Unit casing shall be capable of withstanding 500–hour salt spray exposure per ASTM B117 (scribed specimen).
8. Unit casing shall be capable of withstanding Federal Test Method Standard No. 141 (Method 6061) 5000–hour salt spray.
9. Unit shall be designed in accordance with ISO 9001:2000, and shall be manufactured in a facility registered by ISO 9001:2000.
10. Roof curb shall be designed to conform to NRCA Standards.
11. Unit shall be subjected to a completely automated run test on the assembly line. The data for each unit will be stored at the factory, and must be available upon request.
12. Unit shall be designed in accordance with UL Standard 1995, including tested to withstand rain.
13. Unit shall be constructed to prevent intrusion of snow and tested to prevent snow intrusion into the control box up to 40 mph.
14. Unit shake tested to assurance level 1, ASTM D4169 to ensure shipping reliability.

23 81 19.13.C. Delivery, Storage, and Handling

1. Unit shall be stored and handled per manufacturer's recommendations.
2. Lifted by crane requires either shipping top panel or spreader bars.
3. Unit shall only be stored or positioned in the upright position.

23 81 19.13.E. Project Conditions

1. As specified in the contract.

23 81 19.13.F. Operating Characteristics

1. Unit shall be capable of starting and running at 115°F (46°C) ambient outdoor temperature, meeting maximum load criteria of AHRI Standard 340/360 at ± 10% voltage.
2. Compressor with standard controls shall be capable of operation down to 30°F (-1°C), ambient outdoor temperatures. Accessory winter start kit is necessary if mechanically cooling at ambient temperatures below 30°F (-1°C).
3. Unit shall discharge supply air vertically or horizontally as shown on contract drawings.
4. Unit shall be factory configured and ordered for vertical supply & return configurations.
5. Unit shall be factory furnished for either vertical or horizontal configuration without the use of special conversion kits. No field conversion is possible. The supply air configuration determines the unit model number to be ordered.

23 81 19.13.G. Electrical Requirements

1. Main power supply voltage, phase, and frequency must match those required by the manufacturer.

23 81 19.13.H. Unit Cabinet

1. Unit cabinet shall be constructed of galvanized steel, and shall be bonderized and coated with a pre-painted baked enamel finish on all externally exposed surfaces.
2. Unit cabinet exterior paint shall be: film thickness, (dry) 0.003 inches minimum, gloss (per ASTM D523, 60°F / 16°C): 60, Hardness: H-2H Pencil hardness.
3. Evaporator fan compartment interior cabinet insulation shall conform to AHRI Standard 340/360 minimum exterior sweat criteria. Interior surfaces shall be insulated with a minimum 1/2-in. thick, 1 lb density, flexible fiberglass insulation, neoprene coated on the air side. Aluminum foil-faced fiberglass insulation shall be used in the gas heat compartment.
4. Base of unit shall have a minimum of four locations for thru-the-base gas and electrical connections standard. Both gas and electric connections shall be internal to the cabinet to protect from environmental issues.
5. Base Rail
  - a. Unit shall have base rails on a minimum of 2 sides.
  - b. Holes shall be provided in the base rails for rigging shackles to facilitate maneuvering and overhead rigging.
  - c. Holes shall be provided in the base rail for moving the rooftop by fork truck.
  - d. Base rail shall be a minimum of 16 gauge thickness.
6. Condensate pan and connections:
  - a. Shall be a sloped condensate drain pan made of a non-corrosive material.
  - b. Shall comply with ASHRAE Standard 62.
  - c. Shall use a 3/4-in -14 NPT drain connection, through the side of the drain pan. Connection shall be made per manufacturer's recommendations.
7. Top panel:
  - a. Shall be a multi-piece top panel linked with water tight flanges and locking systems.
8. Gas Connections:
  - a. All gas piping connecting to unit gas valve shall enter the unit cabinet at a single location on side of unit (horizontal plane).
  - b. Thru-the-base capability
    - (1.) Standard unit shall have a thru-the-base gas-line location using a raised, embossed portion of the unit basepan.
    - (2.) Optional, factory-approved, water-tight connection method must be used for thru-the-base gas connections.
    - (3.) No basepan penetration, other than those authorized by the manufacturer, is permitted.
9. Electrical Connections
  - a. All unit power wiring shall enter unit cabinet at a single, factory-prepared, knockout location.
  - b. Thru-the-base capability.
    - (1.) Standard unit shall have a thru-the-base electrical location(s) using a raised, embossed portion of the unit basepan.

(2.) Optional, factory-approved, water-tight connection method must be used for thru-the-base electrical connections.

(3.) No basepan penetration, other than those authorized by the manufacturer, is permitted.

10. Component access panels (standard)

- a. Cabinet panels shall be easily removable for servicing.
- b. Unit shall have one factory installed, tool-less, removable, filter access panel.
- c. Panels covering control box and filter shall have molded composite handles while the blower access door shall have an integrated flange for easy removal.
- d. Handles shall be UV modified, composite. They shall be permanently attached, and recessed into the panel.
- e. Screws on the vertical portion of all removable access panels shall engage into heat resistant, molded composite collars.
- f. Collars shall be removable and easily replaceable using manufacturer recommended parts.

23 81 19.13.I. Gas Heat

1. General

- a. Heat exchanger shall be an induced draft design. Positive pressure heat exchanger designs shall not be allowed.
- b. Shall incorporate a direct-spark ignition system and redundant main gas valve.
- c. Gas supply pressure at the inlet to the rooftop unit gas valve must match that required by the manufacturer.

2. The heat exchanger shall be controlled by an integrated gas controller (IGC) microprocessor.

- a. IGC board shall notify users of fault using an LED (light-emitting diode).
- b. The LED shall be visible without removing the control box access panel.
- c. IGC board shall contain algorithms that modify evaporator-fan operation to prevent future cycling on high temperature limit switch.
- d. Unit shall be equipped with anti-cycle protection with one short cycle on unit flame rollout switch or 4 continuous short cycles on the high temperature limit switch. Fault indication shall be made using an LED.

3. Standard Heat Exchanger construction

- a. Heat exchanger shall be of the tubular-section type constructed of a minimum of 20-gauge steel coated with a nominal 1.2 mil aluminum-silicone alloy for corrosion resistance.
- b. Burners shall be of the in-shot type constructed of aluminum-coated steel.
- c. Burners shall incorporate orifices for rated heat output up to 2000 ft (610m) elevation. Additional accessory kits may be required for applications above 2000 ft (610m) elevation, depending on local gas supply conditions.
- d. Each heat exchanger tube shall contain multiple dimples for increased heating effectiveness.

4. Optional Stainless Steel Heat Exchanger construction

- a. Use energy saving, direct-spark ignition system.
- b. Use a redundant main gas valve.
- c. Burners shall be of the in-shot type constructed of aluminum-coated steel.
- d. All gas piping shall enter the unit cabinet at a single location on side of unit (horizontal plane).
- e. The optional stainless steel heat exchanger shall be of the tubular-section type, constructed of a minimum of 20-gauge type 409 stainless steel.
- f. Type 409 stainless steel shall be used in heat exchanger tubes and vestibule plate.
- g. Complete stainless steel heat exchanger allows for greater application flexibility.

5. Induced draft combustion motor and blower

- a. Shall be a direct-drive, single inlet, forward-curved centrifugal type.
- b. Shall be made from steel with a corrosion-resistant finish.
- c. Shall have permanently lubricated sealed bearings.
- d. Shall have inherent thermal overload protection.
- e. Shall have an automatic reset feature.

23 81 19.13.J. Coils

1. Standard Coils:

- a. Standard evaporator coils shall have aluminum lanced plate fins mechanically bonded to seamless internally grooved copper tubes with all joints brazed.
- b. Evaporator coils shall be leak tested to 150 psig, pressure tested to 450 psig, and qualified to UL 1995 burst test at 1775 psig.

- c. Condenser coils shall be leak tested to 150 psig, pressure tested to 650 psig, and qualified to UL 1995 burst test at 1980 psig.
2. Optional E-coated aluminum-fin condenser coils:
- a. Shall have a flexible epoxy polymer coating uniformly applied to all coil surface areas without material bridging between fins.
  - b. Coating process shall ensure complete coil encapsulation of tubes, fins and headers.
  - c. Color shall be high gloss black with gloss per ASTM D523-89.
  - d. Uniform dry film thickness from 0.8 to 1.2 mil on all surface areas including fin edges.
  - e. Superior hardness characteristics of 2H per ASTM D3363-92A and cross-hatch adhesion of 4B-5B per ASTM D3359-93.
  - f. Impact resistance shall be up to 160 in.-lb (ASTM D2794-93).
  - g. Humidity and water immersion resistance shall be up to minimum 1000 and 250 hours respectively (ASTM D2247-92 and ASTM D870-92).
  - h. Corrosion durability shall be confirmed through testing to be no less than 1000 hours salt spray per ASTM B117-90.

23 81 19.13.K. Refrigerant Components

1. Refrigerant circuit shall include the following control, safety, and maintenance features:
- a. Fixed orifice metering system shall prevent mal-distribution of two-phase refrigerant by including multiple fixed orifice devices in each refrigeration circuit. Each orifice is to be optimized to the coil circuit it serves.
  - b. Refrigerant filter drier – Solid core design.
  - c. Service gauge connections on suction and discharge lines.
  - d. Pressure gauge access through a specially designed access screen on the side of the unit.
2. Compressors
- a. Unit shall use fully hermetic, scroll compressor for each independent refrigeration circuit.
  - b. Models shall be available with 2 compressor/2 stage cooling and microchannel condenser coils.
  - c. Compressor motors shall be cooled by refrigerant gas passing through motor windings.
  - d. Compressors shall be internally protected from high discharge temperature conditions.
  - e. Compressors shall be protected from an over-temperature and over-ampereage conditions by an internal, motor overload device.
  - f. Compressor shall be factory mounted on rubber grommets.
  - g. Compressor motors shall have internal line break thermal, current overload and high pressure differential protection.
  - h. Crankcase heaters shall not be required for normal operating range, unless provided by the factory.

23 81 19.13.L. Filter Section

- 1. Filters access is specified in the unit cabinet section of this specification.
- 2. Filters shall be held in place by a preformed, slide-out filter tray, facilitating easy removal and installation.
- 3. Shall consist of factory-installed, low velocity, throw-away 2-in. thick fiberglass filters.
- 4. Filters shall be standard, commercially available sizes.
- 5. Only one size filter per unit is allowed.
- 6. 4-in filter capability is possible with a field installed pre engineered slide out filter track accessory. 4-in filters are field furnished.

23 81 19.13.M. Evaporator Fan and Motor

1. Evaporator fan motor:
- a. Shall have inherent automatic-reset thermal overload protection or circuit breaker.
  - b. Shall have a maximum continuous bhp rating for continuous duty operation; no safety factors above that rating shall be required.
2. Belt-driven Evaporator Fan:
- a. Belt drive shall include an adjustable-pitch motor pulley and belt break protection system.
  - b. Shall use rigid pillow block bearing system with lubricant fittings at accessible bearing or lubrication line.
  - c. Blower fan shall be double-inlet type with forward-curved blades.
  - d. Shall be constructed from steel with a corrosion resistant finish and dynamically balanced.

23 81 19.13.N. Condenser Fans and Motors

1. Condenser fan motors:
- a. Shall be a totally enclosed motor.

- b. Shall use permanently lubricated bearings.
- c. Shall have inherent thermal overload protection with an automatic reset feature.
- d. Shall use a shaft-down design.

2. Condenser Fans:

- a. Shall be a direct-driven propeller type fan.
- b. Shall have aluminum blades riveted to corrosion-resistant steel spiders and shall be dynamically balanced.

23 81 19.13.O. Special Features Options and Accessories

1. Integrated Economizers:

- a. Integrated, gear-driven parallel modulating blade design type capable of simultaneous economizer and compressor operation.
- b. Independent modules for vertical or horizontal return configurations shall be available. Vertical and horizontal return modules shall be available as a factory installed option.
- c. Damper blades shall be galvanized steel with composite gears. Plastic or composite blades on intake or return shall not be acceptable.
- d. Shall include all hardware and controls to provide free cooling with outdoor air when temperature and/or humidity are below setpoints.
- e. Shall be equipped with gear driven dampers for both the outdoor ventilation air and the return air for positive air stream control.
- f. Shall be equipped with low-leakage dampers, not to exceed 2% leakage at 1 in. wg pressure differential.
- g. Shall be capable of introducing up to 100% outdoor air.
- h. Shall be equipped with a barometric relief damper capable of relieving up to 100% return air.
- i. Shall be designed to close damper(s) during loss-of-power situations with spring return built into motor.
- j. Dry bulb outdoor-air temperature sensor shall be provided as standard. Outdoor air sensor setpoint shall be adjustable and shall range from 40 to 100°F / 4 to 38°C. Additional sensor options shall be available as accessories.
- k. The economizer controller shall also provide control of an accessory power exhaust unit function. Factory set at 100%, with a range of 0% to 100%.
- l. The economizer shall maintain minimum airflow into the building during occupied period and provide design ventilation rate for full occupancy. A remote potentiometer may be used to override the damper setpoint.
- m. Dampers shall be completely closed when the unit is in the unoccupied mode.
- n. Economizer controller shall accept a 2–10Vdc CO<sub>2</sub> sensor input for IAQ/DCV control. In this mode, dampers shall modulate the outdoor-air damper to provide ventilation based on the sensor input.
- o. Compressor lockout sensor shall open at 35°F (2°C) and close closes at 50°F (10°C).
- p. Actuator shall be direct coupled to economizer gear. No linkage arms or control rods shall be acceptable.
- q. Economizer controller shall provide indications when in free cooling mode, in the DCV mode, or the exhaust fan contact is closed.

2. Two-Position Motorized Damper

- a. Damper shall be a Two-Position Damper. Damper travel shall be from the full closed position to the field adjustable %-open setpoint.
- b. Damper shall include adjustable damper travel from 25% to 100% (full open).
- c. Damper shall include single or dual blade, gear driven dampers and actuator motor.
- d. Actuator shall be direct coupled to damper gear. No linkage arms or control rods shall be acceptable.
- e. Damper will admit up to 100% outdoor air for applicable rooftop units.
- f. Damper shall close upon indoor (evaporator) fan shutoff and/or loss of power.
- g. The damper actuator shall plug into the rooftop unit's wiring harness plug. No hard wiring shall be required.
- h. Outside air hood shall include aluminum water entrainment filter.

3. Manual damper

- a. Manual damper package shall consist of damper, air inlet screen, and rain hood which can be preset to admit up to 25% outdoor air for year round ventilation.

4. Head Pressure Control Package

- a. Controller shall control coil head pressure by condenser-fan speed modulation or condenser-fan cycling and wind baffles.
- b. Shall consist of solid-state control and condenser-coil temperature sensor to maintain condensing temperature between 90°F (32°C) and 110°F (43°C) at outdoor ambient temperatures down to -20°F (-29°C).

5. Propane Conversion Kit
  - a. Package shall contain all the necessary hardware and instructions to convert a standard natural gas unit for use with liquefied propane. Kits shall be available for elevations from 0 up to 14,000 ft (4,276m).
6. Condenser Coil Hail Guard Assembly
  - a. Shall protect against damage from hail.
  - b. Shall be louvered style design.
7. Unit–Mounted, Non–Fused Disconnect Switch:
  - a. Switch shall be factory–installed, internally mounted.
  - b. National Electric Code (NEC) and UL approved non–fused switch shall provide unit power shutoff.
  - c. Shall be accessible from outside the unit.
  - d. Shall provide local shutdown and lockout capability.
8. Convenience Outlet:
  - e. Non–Powered convenience outlet.
    - (1.) Outlet shall be powered from a separate 115/120v power source.
    - (2.) A transformer shall not be included.
    - (3.) Outlet shall be factory–installed and internally mounted with easily accessible 115–v female receptacle.
    - (4.) Outlet shall include 15 amp GFI receptacles with independent fuse protection.
    - (5.) Outlet shall be accessible from outside the unit.
9. Flue Discharge Deflector:
  - a. Flue discharge deflector shall direct unit exhaust vertically instead of horizontally.
  - b. Deflector shall be defined as a “natural draft” device by the National Fuel and Gas (NFG) code.
10. Centrifugal Propeller Power Exhaust:
  - a. Power exhaust shall be used in conjunction with an integrated economizer.
  - b. Independent modules for vertical or horizontal return configurations shall be available.
  - c. Horizontal power exhaust is shall be mounted in return ductwork.
  - d. Power exhaust shall be controlled by economizer controller operation. Exhaust fans shall be energized when dampers open past the 0–100% adjustable setpoint on the economizer control.
11. Roof Curbs (Vertical):
  - a. Full perimeter roof curb with exhaust capability providing separate air streams for energy recovery from the exhaust air without supply air contamination.
  - b. Formed galvanized steel with wood nailer strip and shall be capable of supporting entire unit weight.
  - c. Permits installation and securing of ductwork to curb prior to mounting unit on the curb.
12. High Altitude Gas Conversion Kit:
  - a. Package shall contain all the necessary hardware and instructions to convert a standard natural gas unit to operate from 3,000–10,000 ft (914 to 3048m) elevation and 10,001–14,000 ft (3049–4267m) elevation.
13. Outdoor Air Enthalpy Sensor:
  - a. The outdoor air enthalpy sensor shall be used to provide single enthalpy control. When used in conjunction with a return air enthalpy sensor, the unit will provide differential enthalpy control. The sensor allows the unit to determine if outside air is suitable for free cooling.
14. Return Air Enthalpy Sensor:
  - a. The return air enthalpy sensor shall be used in conjunction with an outdoor air enthalpy sensor to provide differential enthalpy control.
15. Indoor Air Quality (CO<sub>2</sub>) Sensor:
  - a. Shall be able to provide demand ventilation indoor air quality (IAQ) control.
  - b. The IAQ sensor shall be available in duct mount. The setpoint shall have adjustment capability.
16. Smoke detectors (Supply):
  - a. Shall be a Four–Wire Controller and Detector.
  - b. Shall be environmental compensated with differential sensing for reliable, stable, and drift–free sensitivity.
  - c. Shall use magnet–activated test/reset sensor switches.
  - d. Shall have tool–less connection terminal access.
  - e. Shall have a recessed momentary switch for testing and resetting the detector.
  - f. Controller shall include:
    - (1.) One set of normally open alarm initiation contacts for connection to an initiating device circuit on a fire alarm control panel.



- (2.) Two Form-C auxiliary alarm relays for interface with rooftop unit or other equipment.
  - (3.) One Form-C supervision (trouble) relay to control the operation of the Trouble LED on a remote test/reset station.
  - (4.) Capable of direct connection to two individual detector modules.
  - (5.) Can be wired to up to 14 other duct smoke detectors for multiple fan shutdown applications
17. Winter start kit
- a. Shall contain a bypass device around the low pressure switch.
  - b. Shall be required when mechanical cooling is required down to 25°F (-4°C).
  - c. Shall not be required to operate on an economizer when below an outdoor ambient of 40°F (4°C).
18. Time Guard
- a. Shall prevent compressor short cycling by providing a 5-minute delay (±2 minutes) before restarting a compressor after shutdown for any reason.
  - b. One device shall be required per compressor.
19. Barometric Hood (Horizontal Economizer Applications)
- a. Shall be required when a horizontal economizer and barometric relief are required. Barometric relief damper must be installed in the return air (horizontal) duct work. This hood provides weather protection.
20. Hinged Access Panels
- a. Shall provide easy access through integrated quarter turn latches.
  - b. Shall be on major panels of; filter, control box, fan motor and compressor.