

PACKAGE GAS / ELECTRIC UNIT – 71 to 136 MBtuh Meets Ashrae 90.1 – Efficiency Standards

REFRIGERATION CIRCUIT

- Scroll compressors on most Models.
- High and Low pressure switches and evaporator evaporator freeze thermostat.
- PGE090–150 have two stages of cooling, PGE072 is single stage.
- Anti–cycle timer built into the electronic board.

BUILT TO LAST

- Tubular, dimpled heat exchangers.
- Pre–painted galvanized steel cabinet for long life and quality appearance.
- Integral Commercial strength base rails. Holes provided for lifting lugs makes rooftop installation easier.
- Non–corrosive, sloped condensate drain pan, meets ASHRAE 62.

EASY TO INSTALL AND SERVICE

- Combination gas heating and electric cooling, self contained for year-round comfort. Systems installed on rooftop or ground level. The unit is shipped in the horizontal position and can easily be converted to downflow.
- Thru–the–bottom utility connection capability allow power, control wiring, and gas to be routed through unit base pan, minimizing roof penetrations.
- Exclusive integrated gas control board with diagnostics.
- Induced–draft fan for gas combustion.
- Direct–spark ignition systems.
- Factory wired to accept economizer.
- Refrigerant filter drier.

WARRANTY

- 10 year limited heat exchanger warranty
- 5 year compressor limited warranty
- 1 year parts limited warranty



PGE090 – 150 Shown



UNIT PERFORMANCE DATA

Model Number *	COOLING			HEATING		Unit Dimensions H X W X L	Unit Weight
	Rated Capacity BTUH	E.E.R	IPLV	Input (MBTUH) Std. Stage 2 / Stage 1	Efficiency (Steady State) (AFUE) Std.		
PGE072H150A	71,000	10.1	n/a	150,000 / 120,000	80	33-5/16" x 45" x 73-11/16"	615
PGE072L150A	71,000	10.1	n/a	150,000 / 120,000	80	33-5/16" x 45" x 73-11/16"	615
PGE072S150A	71,000	10.1	n/a	150,000 / 120,000	80	33-5/16" x 45" x 73-11/16"	615
PGE090H224A	87,000	10.1	10.4	224,000 / 180,000	80	41-5/16" x 57-3/4" x 87-3/8"	870
PGE090L224A	87,000	10.1	10.4	224,000 / 180,000	80	41-5/16" x 57-3/4" x 87-3/8"	870
PGE090S224A	87,000	10.1	10.4	224,000 / 180,000	80	41-5/16" x 57-3/4" x 87-3/8"	870
PGE102H224A	100,000	10.1	10.4	224,000 / 180,000	80	41-5/16" x 57-3/4" x 87-3/8"	880
PGE102L224A	100,000	10.1	10.4	224,000 / 180,000	80	41-5/16" x 57-3/4" x 87-3/8"	880
PGE102S224A	100,000	10.1	10.4	224,000 / 180,000	80	41-5/16" x 57-3/4" x 87-3/8"	880
PGE120H250A	112,000	10.1	10.9	250,000 / 200,000	80	49-15/16" x 57-3/4" x 87-3/8"	1035
PGE120L250A	112,000	10.1	10.9	250,000 / 200,000	80	49-15/16" x 57-3/4" x 87-3/8"	1035
PGE120S250A	112,000	10.1	10.9	250,000 / 200,000	80	49-15/16" x 57-3/4" x 87-3/8"	1035
PGE150H250A	136,000	9.5	10.2	250,000 / 200,000	80	49-15/16" x 57-3/4" x 87-3/8"	1050
PGE150L250A	136,000	9.5	10.2	250,000 / 200,000	80	49-15/16" x 57-3/4" x 87-3/8"	1050
PGE150S250A	136,000	9.5	10.2	250,000 / 200,000	80	49-15/16" x 57-3/4" x 87-3/8"	1050

* Unit voltage: H = 208/230v, L = 460v, S = 575v

Table of Contents

	Page
Features/Benefits	1
Model Number Nomenclature	2
Unit Specifications	3-5
Dimensions	6-7
Performance Data	8-16
Typical Installation	17
Accessories	18-27
Controls	28
Guide Specs	28

MODEL NUMBER IDENTIFICATION GUIDE							
MODEL NUMBER	P	G	E	090	H	224	A
PRODUCT FAMILY Package Units							Sales Code
TYPE H= Heat Pump G = Gas/Electric A = Air Conditioner							GAS HEATING OPTIONS (BTUH) 150 = 150,000 224 = 224,000 250 = 250,000
DESIGN SERIES E = Ashrae Compliant							VOLTAGE / PHASE / HERTZ H = 208/230-3-60 L = 460-3-60 S = 575-3-60
							COOLING CAPACITY (NOMINAL BTUH) 072 = 6 Ton 090 = 7-1/2 Ton 102 = 8-1/2 Ton 120 = 10 Ton 150 = 12-1/2 Ton

UNIT SPECIFICATIONS (Legend on Page 5)				MODELS					
COOLING	PGE072H	PGE072L	PGE072S	PGE090H	PGE090L	PGE090S	PGE102H	PGE102L	PGE102S
ARI Rated Capacity Btuh (Net)	71,000			87,000			100,000		
Nominal Tons	6			7-1/2			8-1/2		
Standard CFM	2400			2800			3200		
EER	10.1			10.1			10.1		
IPLV	n/a			10.4			10.4		
Sound Rating (Bels)	8.0			8.7			8.2		
Unit Weight (lbs. / kg)	615 / 279			870 / 395			880 / 475		
ELECTRICAL	PGE072H	PGE072L	PGE072S	PGE090H	PGE090L	PGE090S	PGE102H	PGE102L	PGE102S
Volts/ 3 Phase/ 60Hertz	208/230	460	575	208/230	460	575	208/230	460	575
Voltage Range Min/Max	187 / 254	414 / 508	518 / 632	187 / 254	414 / 508	518 / 632	187 / 254	414 / 508	518 / 632
Power Supply MCA	32.4 / 32.4	15.4	11.4	40.1 / 40.1	18.4	14.9	44.3 / 44.3	21.8	18.9
Power Supply MOCPS*	40 / 40	20	20	45 / 45	20	20	50 / 50	25	25
COMPRESSOR - QTY	SCROLL - 1			RECIPROCATING - 2			SCROLL - 2		
Quantity...Model	SR(Y,H,J)682AE*			CR46K6			SR(Y,H,J)482AC / SR(Y,H,J)552HE*		
Oil (Oz.)	60			42 ea			60 ea		
RLA / LRA	20.6 / 146.0	9.5 / 73.0	8.6 / 58.1	14.0 / 91.0	6.4 / 42.0	5.2 / 39.0	17.3 / 120	7.9 / 70.0	5.5 / 50.0
REFRIGERANT TYPE	R-22								
Expansion Device	Fixed Orifice Metering Device								
Operating Charge...lb. oz....Circuit 1	11 - 0			7 - 6			9 - 8		
...Circuit 2	n/a			8 - 1			9 - 5		
CONDENSER FAN	Propeller Type								
Nominal CFM	4100			6400			7000		
Quantity..Diameter (In.)	1...22			2...22			2...22		
Motor Hp...RPM	1/4...1100			1/4...1100			1/4...1100		
Watts Input (Total)	320			600			650		
FLA	1.4	0.9	0.6	1.4	0.7	0.7	1.4	0.7	0.7
CONDENSER COIL	Enhanced Copper Tubes, Aluminum Lanced fins								
Rows...Fin/In.	2...17			2...17			2...17		
Total Face Area (Sq. Ft..)	16.50			20.50			20.50		
EVAPORATOR COIL	Enhanced Copper Tubes, Aluminum Double Wavy Fins								
Rows...Fins/Inch	4...15			3...15			3...15		
Total Face Aea (sq. ft.)	5.5			8.9			8.9		
EVAPORATOR FAN	Centrifugal Type								
Quantity...Size (in.)	1...10 x 10			1...15 x 15			1...15 x 15		
Type Drive	Belt			Belt			Belt		
Nominal CFM	2100			3000			3000		
Max. Continuous Bhp	2.4			2.4			2.4		
FLA-208-230/460/575V	5.2/2.6/2.6			5.8/2.6/2.6			5.8/2.6/2.6		
Motor Frame Size	56			56			56		
Fan RPM Range	1070-1460			590-840			685-935		
Motor Bearing	Ball			Ball			Ball		
Maximum Allowable RPM	2100			2100			2100		
Motor Pulley Pitch / Diameter Min/Max. (in.)	2.8 / 3.8			2.4 / 3.4			2.8 / 3.8		
Motor Shaft Diameter (in.)	5/8			5/8			5/8		
Fan Pulley Pitch Diam (in)	4.5			7.0			7.0		
Belt, Quantity...Type... Length (in.)	1...A..39			1...A..49			1...A..48		
Pulley Center Line Distance (in)	16.75-19.25			16.75-19.25			16.75-19.25		
Speed Change per Full Turn of Movable Pulley Flange (RPM)	80			50			50		
Pulley Max. full Turns From Closed Postion	5			5			5		
Factory Setting	3			5			5		
Factory Speed Setting RPM	1226			590			685		
Fan Shaft Diam. at Pulley	5/8			1			1		

* Y = 208/230V, H = 460V, J = 575V.

UNIT SPECIFICATIONS (Legend on Next Page)		MODELS				
COOLING	PGE120H	PGE120L	PGE120S	PGE150H	PGE150L	PGE150S
ARI Rated Capacity Btuh (Net)	112,000			136,000		
Nominal Tons	10			12-1/2		
Standard CFM	4000			4500		
EER	10.1			9.5		
IPLV	10.9			10.2		
Sound Rating (Bels)	8.8			8.7		
Unit Weight (lbs. / kg)	1035 / 469			1050 / 476		
ELECTRICAL	PGE120H	PGE120L	PGE120S	PGE150H	PGE150L	PGE150S
Volts/ 3 Phase/ 60Hertz	208/230	460	575	208/230	460	575
Voltage Range Min/Max	187 / 254	414 / 508	518 / 632	187 / 254	414 / 508	518 / 632
Power Supply MCA	44.2 / 44.2	21.8	18.9	60.6 / 60.6	29.1	23.7
Power Supply MOCP*	50 / 50	25	25	70 / 70	40	30
COMPRESSOR - QTY	SCROLL - 2			SCROLL - 2		
Model	SR582AE			ZR68KC		
Oil (Oz.)	54 ea			60 ea		
RLA / LRA	15.8 / 130	7.9 / 64.0	6.6 / 52.0	19 / 156.0	9.0 / 70.0	7.4 / 54.0
REFRIGERANT TYPE	R-22					
Expansion Device	Fixed Orifice Metering Device					
Operating Charge....lb. oz....Circuit 1	7 - 3			9 - 8		
.....Circuit 2	7 - 13			9 - 5		
CONDENSER FAN	Propeller Type					
Nominal CFM	7000			7000		
Quantity..Diameter (In.)	2...22			2...22		
Motor Hp...RPM	1/4...1100			1/4...1100		
Watts Input (Total)	600			650		
FLA	1.4	0.7	0.7	1.4	0.7	0.7
CONDENSER COIL	Enhanced Copper Tubes, Aluminum Lanced fins					
Rows...Fin/In.	2...17			2...17		
Total Face Area (Sq. Ft.)	20.47			25.0		
EVAPORATOR COIL	Enhanced Copper Tubes, Aluminum Double Wavy Fins					
Rows...Fins/Inch	3...15			4...15		
Total Face Aea (sq. ft.)	10.0			11.1		
EVAPORATOR FAN	Centrifugal Type					
Quantity...Size (in.)	1...15 x 15			1...15 x 15		
Type Drive	Belt			Belt		
Nominal CFM	4000			5000		
Max. Continuous Bhp	2.4			5.25		
FLA-208-230/460/575V	5.8/2.6/2.6			15.0/7.4/7.4		
Motor Frame Size	56			56		
Fan RPM Range	685-935			900-1260		
Motor Bearing	Ball			Ball		
Maximum Allowable RPM	2100			2100		
Motor Pulley Pitch / Diameter Min/Max. (in.)	2.8 / 3.8			2.8 / 3.8		
Motor Shaft Diameter (in.)	5/8			7/8		
Fan Pulley Pitch Diam (in)	7.0			8.0		
Belt, Quantity...Type... Length (in.)	1...A...49			1...A...52		
Pulley Center Line Distance (in)	15.85-17.50			15.85-17.50		
Speed Change per Full Turn of Movable Pulley Flange (RPM)	50			60		
Pulley Max. full Turns From Closed Postion	5			6		
Factory Setting	5			5		
Factory Speed Setting RPM	685			960		
Fan Shaft Diam. at Pulley	1			1		

UNIT SPECIFICATIONS (CONT)		MODELS				
FURNACE SECTION		PGE072	PGE090	PGE102	PGE120	PGE150
Rollout Switch Cutout Temp (F)		195	195	195	195	195
Burner Orifice Diameter (in. .drill size)						
Natural Gas		113...33	120...31	120...31	129...30	129...30
Liquid Propane		089...43	096...41	096...41	102...38	102...38
Thermostat Heat Anticipator Setting (amps)						
208/230 v and 575v	Stage 1	14	14	14	14	14
208/230 v and 575v	Stage 2	14	20	20	20	20
460 v	Stage 1	14	14	14	14	14
460 v	Stage 2	14	20	20	20	20
Gas Input (Btuh)						
Stage 2 / Stage 1		150,000 / 120,000	224,000 / 180,000	224,000 / 180,000	250,000 / 200,000	250,000 / 200,000
Output Capacity (Btuh)		120,000	179,200	179,200	200,000	200,000
Efficiency (Steady State) (%) AFUE		80	80	80	80	80
Temperature Rise Range		50-80	45-75	45-75	40-70	40-70
Manifold Pressure (in. wg)						
Natural Gas		3.5	3.5	3.5	3.5	3.5
Liquid Propane		3.5	3.5	3.5	3.5	3.5
Gas Valve Quantity						
Gas Valve Pressure Range	Psig	0.180-0.487	0.180-0.487	0.180-0.487	0.180-0.487	0.180-0.487
	in. wg	5.0-13.5	5.0-13.5	5.0-13.5	5.0-13.5	5.0-13.5
Field Gas Connection Size (in.)						
		1/2	3/4	3/4	3/4	3/4
HIGH-PRESSURE SWITCH (psig)						
Standard Compressor		500 +/- 50	450 +/- 50	450 +/- 50	450 +/- 50	450 +/- 50
Internal Relief (Differential) Cutout		428	428	428	428	428
Reset (Auto.)		320	320	320	320	320
LOSS-OF-CHARGE SWITCH (psig) (LOW-PRESS.)						
Cutout		7 +/- 3	7 +/- 3	7 +/- 3	7 +/- 3	7 +/- 3
Reset (Auto.)		22 +/- 7	22 +/- 7	22 +/- 7	22 +/- 7	22 +/- 7
FREEZE PROTECTION THERMOSTAT (F)						
Opens		30 +/- 5	30 +/- 5	30 +/- 5	30 +/- 5	30 +/- 5
Closes		45 +/- 5	45 +/- 5	45 +/- 5	45 +/- 5	45 +/- 5
RETURN-AIR FILTERS (THROWAWAY)						
Quantity...Size (in.)		2...16 x 25 x 2	4...16 x 20 x 2	4...20 x 20 x 2	4...20 x 20 x 2	4...20 x 20 x 2

LEGENDS AND NOTES

Bhp = Brake Horsepower

Legend

Bels	-	Sound Levels
EER	-	Energy Efficiency Ratio
IPLV	-	Integrated Part Load Values
MCA	-	Minimum Circuit Amps
MOCP	-	Maximum Over-current Protection
FLA	-	Full Load Amps
LRA	-	Locked Rotor Amps
*	-	Fuse or HACR circuit breaker
RLA	-	Rated Load Amps

NOTES:

1. In compliance with NEC requirements for multimotor and combination load equipment (refer to NEC Articles 430 and 440), the over-current protective device for the unit shall be fuse or HACR breaker. Canadian units may be fuse or circuit breaker.

2. Unbalanced 3-Phase Supply Voltage

Never operate a motor where a phase imbalance in supply voltage is greater than 2%. Use the following formula to determine the percent voltage imbalance.

% Voltage Imbalance

$$= 100 \times \frac{\text{max voltage deviation from average voltage}}{\text{average voltage}}$$

- NOTES: 1. Rated in accordance with ARI Standards 210/240, latest revision (for sizes 090 & 120) or 360, latest revision (for size 150).
 2. ARI ratings are net values, reflecting the effects of circulating fan heat.
 3. Ratings are based on:
 Cooling Standard: 80F db, 67F wb indoor entering air temperature and 95F db air entering outdoor unit.
 IPLV Standard: 80F db, 67F wb indoor entering air temperature and 80F db entering air temperature.

EXAMPLE: Supply voltage is 460-3-60.

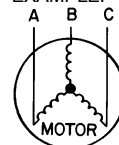

$$\begin{aligned} AB &= 452 \text{ v} & \text{Average Voltage} &= \frac{452 + 464 + 455}{3} \\ BC &= 464 \text{ v} & &= \frac{1371}{3} \\ AC &= 455 \text{ v} & &= 457 \end{aligned}$$

Determine maximum deviation from average voltage.

$$(AB) 457 - 452 = 5 \text{ V}$$

$$(BC) 464 - 457 = 7 \text{ V}$$

$$(AC) 457 - 455 = 2 \text{ V}$$

Maximum deviation is 7 v.

Determine percent voltage imbalance.

$$\% \text{ Voltage Imbalance} = 100 \times \frac{7}{457} = 1.53\%$$

This amount of phase imbalance is satisfactory as it is below the maximum allowable 2%.

IMPORTANT: If the supply voltage phase imbalance is more than 2%, contact your local electric utility company immediately.

BASE UNIT WEIGHT AND DIMENSIONS - PGE072

Unit	Total Weight		Corner A		Corner B		Corner C		Corner D		Dim K	
	lb	kg	lb	kg	lb	kg	lb	kg	lb	kg	inches	mm
PGE072	615	279	147	67	142	65	160	73	166	75	19-3/16	847

All measurements in inches (mm)

THREADED CONDUIT SIZE	WIRE USE	REQUIRED HOLE SIZES (MAX.)
1/2"	ACC	7/8" [22]
1/2"	24	7/8" [22]
3/4"	Power*	1-1/8" [28.4]
1-1/4" FPT	Power*	1-3/4" [44.4]
1/2" FPT	GAS	1-1/4" [31.8]
3/4" FPT	GAS	1-5/8" [41.3]

* Select either 3/4" or 1-1/4" for power, depending on wire size.

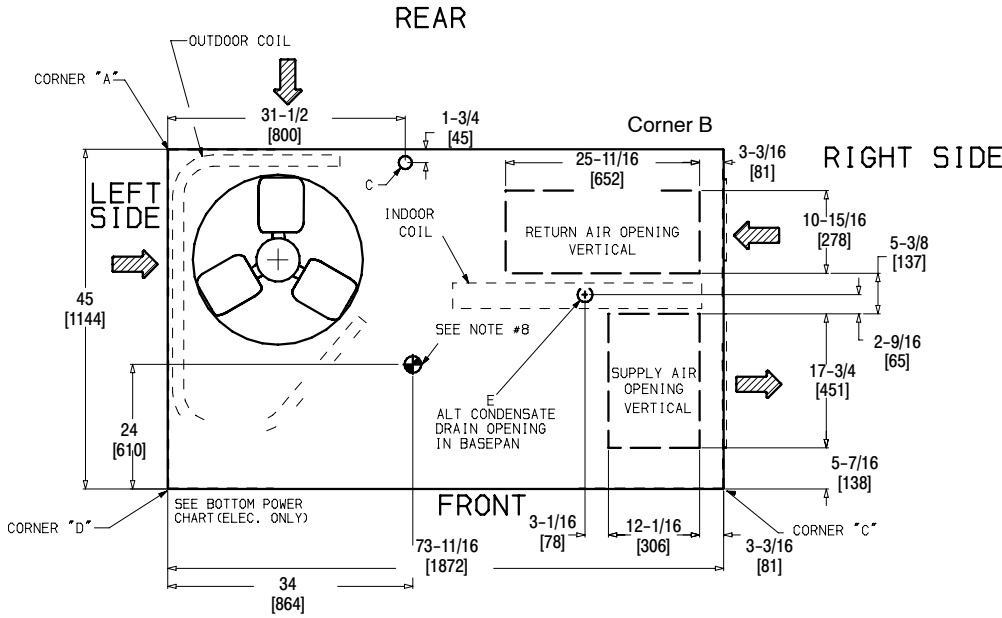

Connection Sizes - PGE072	
A	1-3/8" Dia (35) Field Power Supply Hole
B	2" Dia (51) Power Supply Knockout
C	1-3/4" Dia (44) Charging Port Hole
D	7/8" Dia (22) Field Control Wiring Hole
E	3/4"-14 NPT Condensate Drain
F	1/2"-14NPT Gas Connection
G	2-1/2" Dia (64) Power Supply Knockout

Connection Sizes - PGS072	
A	1-3/8" Dia (35) Field Power Supply Hole
B	2" Dia (51) Power Supply Knockout
C	2-1/2" Dia (44) Charging Port Hole
D	7/8" Dia (22) Field Control Wiring Hole
E	3/4"-14 NPT Condensate Drain
F	1/2"-14 NPT Gas Connection

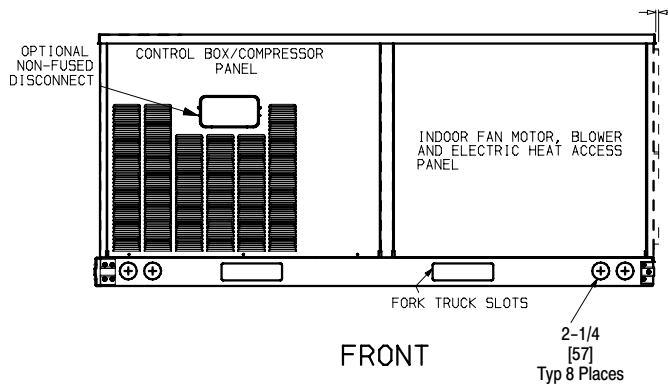
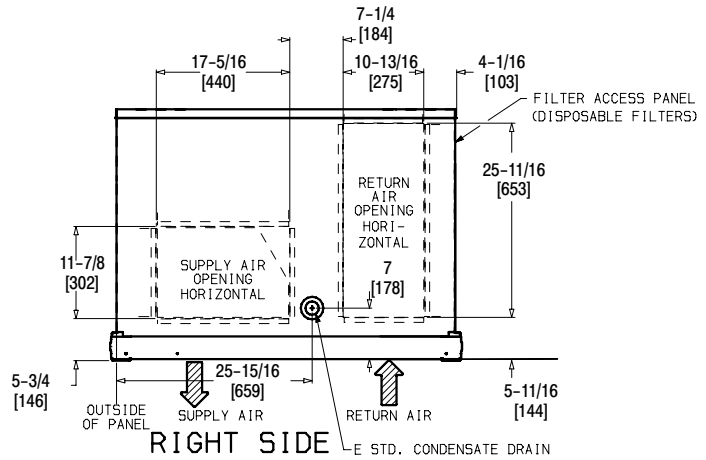
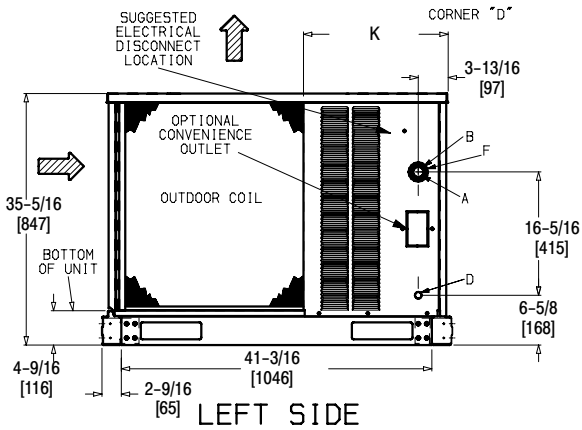

Unit	Total		Corner A		Corner B		Corner C		Corner D		Dim A		Dim B		Dim C	
Size	lb	kg	lb	kg	lb	kg	lb	kg	lb	kg	inches	mm	inches	mm	inches	mm
PGE090	870	395	189	86	161	73	239	109	280	127	14 ⁷ / ₈	378	41 ⁵ / ₁₆	1050	35 ¹¹ / ₁₆	856
PGE102	880	399	191	87	153	74	242	110	284	129	39 ⁷ / ₈	1013	41 ⁵ / ₁₆	1050	35 ¹¹ / ₁₆	856
PGE120	1035	489	225	102	192	87	285	129	333	151	29 ⁷ / ₈	759	49 ¹⁵ / ₁₆	1253	3 ³ / ₈	924
PGE150	1050	476	228	103	195	88	289	131	338	153	14 ⁷ / ₈	378	49 ¹⁵ / ₁₆	1253	3 ³ / ₈	924

All measurements in inches (mm)

THREADED CONDUIT SIZE	WIRE USE	REQUIRED HOLE SIZES (MAX.)
1/2"	24	7/8" [22]
3/4"	Power*	1-1/8" [28.4]
1-1/4" FPT	Power*	1-3/4" [44.4]

* Select either 3/4" or 1-1/4" for power, depending on wire size.

Connection Sizes	
D	1-3/8" Dia (35) Field Power Supply Hole
E	2-1/2" Dia (64) Power Supply Knockout
F	1-3/4" Dia (44) Charging Port Hole
G	7/8" Dia (22) Field Control Wiring Hole
H	3/4"-14 NPT Condensate Drain
I	2" Dia (51) Power Supply Knockout
J	3/4"-14 NPT Gas connection
K	26-7/16 (090) 34-7/16 (120 & 150 MODELS)

**BASE UNIT WEIGHT AND DIMENSIONS
PGE090-150**

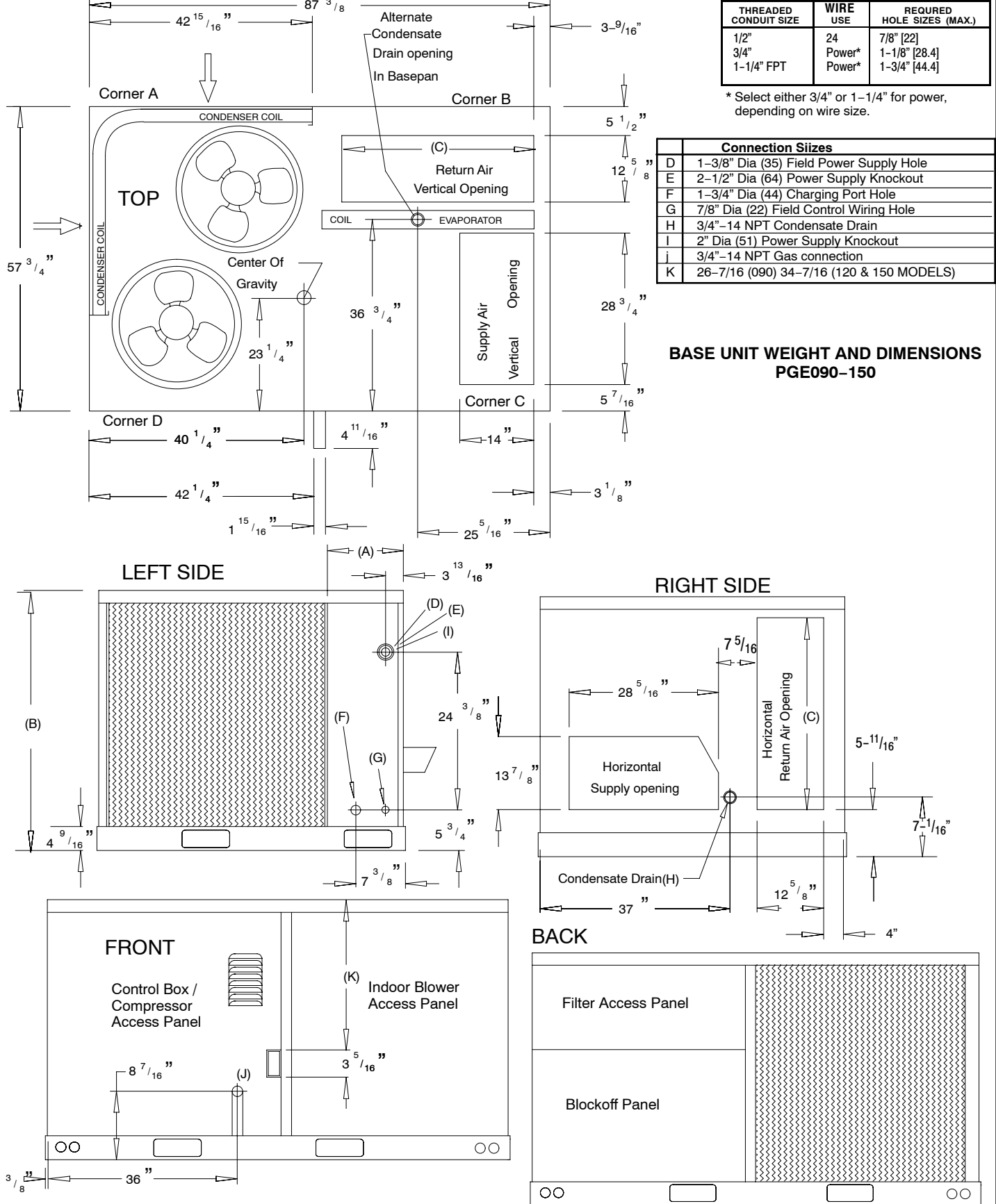

EXPANDED PERFORMANCE DATA (COOLING) 6 TON (GROSS CAPACITY)

Temp (F) Air Entering Condenser (Edb)		Air Entering Evaporator — Cfm/BF											
		1800/0.06			2100/0.07			2400/0.09			3000/0.11		
		Air Entering Evaporator — Ewb (F)											
		72	67	62	72	67	62	72	67	62	72	67	62
75	TC	81.3	77.8	71.3	82.7	78.7	72.9	84.2	79.7	74.6	85.3	82.5	76.7
	SHC	38.2	51.3	61.6	40.2	54.2	65.9	42.3	57.1	70.2	43.7	64.0	76.4
	kW	4.69	4.63	4.52	4.73	4.65	4.56	4.77	4.67	4.60	4.80	4.75	4.63
85	TC	78.8	75.6	69.0	81.1	77.1	70.7	83.3	78.6	72.3	85.0	80.5	75.0
	SHC	37.7	50.4	60.5	40.0	53.9	64.9	42.2	57.5	69.2	44.3	63.6	74.9
	kW	5.21	5.16	5.05	5.27	5.20	5.09	5.34	5.24	5.13	5.39	5.29	5.17
95	TC	77.1	73.3	66.9	79.2	74.8	68.5	81.3	76.2	70.1	82.0	78.0	73.3
	SHC	37.0	49.9	59.7	39.4	53.3	64.0	41.8	56.8	68.3	43.5	63.4	73.2
	kW	5.80	5.78	5.65	5.87	5.81	5.70	5.94	5.85	5.74	5.95	5.88	5.8
105	TC	75.4	70.7	62.9	76.6	72.1	64.8	77.9	73.4	66.7	79.7	74.9	70.9
	SHC	36.7	48.7	58.2	38.6	52.3	62.2	40.6	55.9	66.3	43.0	62.4	70.9
	kW	6.49	6.45	6.26	6.53	6.48	6.32	6.56	6.51	6.38	6.61	6.53	6.46
115	TC	72.1	67.9	59.0	73.6	69.0	61.1	75.2	70.1	63.3	76.7	71.9	68.1
	SHC	35.3	47.5	57.2	37.6	51.2	60.2	39.9	54.8	63.3	42.2	61.5	68.1
	kW	7.20	7.17	6.94	7.25	7.18	7.01	7.29	7.20	7.08	7.35	7.26	7.15

LEGEND

- BF — Bypass Factor
- Edb — Entering Dry-Bulb
- Ewb — Entering Wet-Bulb
- kW — Compressor Motor Power Input
- Ldb — Leaving Dry-Bulb
- Lwb — Leaving Wet-Bulb
- SHC — Sensible Heat Capacity (1000 Btuh) Gross
- TC — Total Capacity (1000 Btuh) Gross

NOTES:

1. Direct interpolation is permissible. Do not extrapolate.
2. The following formulas may be used:

$$t_{ldb} = t_{edb} - \frac{\text{sensible capacity (Btuh)}}{1.10 \times \text{cfm}}$$

t_{lwb} = Wet-bulb temperature corresponding to enthalpy of air leaving evaporator coil (h_{lwb})

$$h_{lwb} = h_{ewb} - \frac{\text{total capacity (Btuh)}}{4.5 \times \text{cfm}}$$

Where: h_{ewb} = Enthalpy of air entering evaporator coil.

3. The SHC is based on 80 F edb temperature of air entering evaporator coil.
Below 80 F edb, subtract (corr factor x cfm) from SHC.
Above 80 F edb, add (corr factor x cfm) to SHC.

BYPASS FACTOR (BF)	ENTERING AIR DRY-BULB TEMP (F)					
	79	78	77	76	75	under 75
	81	82	83	84	85	over 85
Correction Factor						
.05	1.04	2.07	3.11	4.14	5.18	Use formula shown below.
.10	.98	1.96	2.94	3.92	4.90	
.20	.87	1.74	2.62	3.49	4.36	
.30	.76	1.53	2.29	3.05	3.82	

Interpolation is permissible.

Correction Factor = $1.10 \times (1 - BF) \times (edb - 80)$.

EXPANDED PERFORMANCE DATA (COOLING) 7-1/2 Ton (GROSS Capacity)

Airflow CFM IDB (BF)			Outdoor Ambient Temperature - Degrees F, Dry Bulb														
			75			85			95			105			115		
			Entering Indoor Air Temperature - Degrees F, Wet Bulb														
			62	67	72	62	67	72	62	67	72	62	67	72	62	67	72
80	3750 (0.14)	MBH	94.0	102.0	109.6	90.0	97.2	105.0	85.5	91.6	99.8	80.9	85.7	94.2	76.3	79.7	87.9
		S/T	0.99	0.76	0.53	1.00	0.79	0.54	1.00	0.82	0.56	1.00	0.85	0.58	1.00	0.89	0.60
		KW	6.00	6.28	6.52	6.47	6.71	6.98	6.92	7.13	7.43	7.36	7.55	7.85	7.82	7.96	8.29
	3000 (0.11)	MBH	91.2	99.4	106.8	86.3	94.8	103.0	81.5	89.4	98.0	76.3	83.7	92.0	71.3	77.7	85.9
		S/T	0.93	0.71	0.50	0.95	0.73	0.51	0.97	0.75	0.53	0.99	0.78	0.54	1.00	0.81	0.56
		KW	5.87	6.15	6.40	6.31	6.59	6.87	6.73	7.03	7.34	7.17	7.43	7.75	7.62	7.83	8.16
	2800 (0.11)	MBH	90.4	98.6	106.2	85.5	94.0	102.2	80.3	88.7	97.4	74.9	83.1	91.4	69.9	77.1	85.5
		S/T	0.91	0.69	0.50	0.93	0.71	0.51	0.97	0.73	0.52	0.99	0.76	0.53	1.00	0.79	0.54
		KW	5.84	6.10	6.36	6.28	6.56	6.84	6.68	6.99	7.31	7.12	7.40	7.69	7.55	7.80	8.13
	2250 (0.10)	MBH	86.5	95.2	103.2	81.9	90.6	98.8	76.9	85.5	94.2	71.1	80.1	88.7	66.3	74.1	83.1
		S/T	0.85	0.65	0.48	0.87	0.67	0.49	0.90	0.68	0.49	0.93	0.70	0.50	0.96	0.73	0.51
		KW	5.68	5.96	6.24	6.12	6.42	6.70	6.54	6.85	7.15	6.98	7.26	7.59	7.36	7.68	8.01

FORMULAS AND NOTES FOR USING EXPANDED PERFORMANCE DATA

To find leaving wet bulb and dry bulb from the expanded performance charts, use the following formulas.

- Direct interpolation is permissible. Do not extrapolate.
- The following formulas may be used:
 $t/db = t\ edb - \text{sensible capacity Btuh} / (1.10 \times \text{cfm})$
 $t/wb = \text{Wet bulb temp. corresponding to enthalpy of air leaving evaporator coil (h/wb)}$
 $h/wb = h\ ewb - \text{total capacity Btuh} / (4.5 \times \text{cfm})$
 where h ewb = Enthalpy of air entering evap. coil
- The SHC is based on 80F edb of air entering evap coil. Below 80F edb, subtract (corr factor x cfm) from SHC. Above 80F edb, add (corr factor x cfm) to SHC.

LEGEND	
MBH	= Total Capacity (Gross)
S/T	= Sensible to Total Ratio
KW	= Compressor Motor Power Input.
IDB	= Indoor Dry Bulb
edb	= Entering Dry Bulb
ewb	= Entering Wet Bulb
t/db	= Leaving Dry Bulb
t/wb	= Leaving Wet Bulb
h/wb	= Enthalpy of Leaving Wet Bulb
SHC	= Sensible Heat Capacity

BYPASS FACTOR (BF)	ENTERING AIR DRY BULB						Use formulas shown below
	79	78	77	76	75	under 75	
	81	82	83	84	85	over 85	
Correction Factor							
.05	1.04	2.07	3.11	4.14	5.18		
.10	0.98	1.96	2.94	3.92	4.90		
.20	0.87	1.74	2.62	3.49	4.36		
.30	0.76	1.53	2.29	3.05	3.82		

Correction Factor = 1.10 x (1-BF) x (edb-80).

EXPANDED PERFORMANCE DATA (COOLING) 8-1/2 TON (GROSS CAPACITY)

Temp (F) Air Entering Condenser (Edb)		Air Entering Evaporator — Cfm/BF											
		2550/0.08			3000/0.09			3400/0.11			4250/0.13		
		Air Entering Evaporator — Ewb (F)											
		72	67	62	72	67	62	72	67	62	72	67	62
75	TC	117.7	104.1	93.4	121.3	107.5	97.2	122.9	109.0	98.7	124.4	111.1	101.8
	SHC	55.7	64.7	76.6	59.3	70.6	85.0	61.3	74.7	91.4	66.8	82.1	99.7
	kW	6.42	6.34	6.26	6.46	6.38	6.30	6.47	6.39	6.33	6.50	6.41	6.35
85	TC	113.8	100.4	89.2	117.9	103.8	93.4	119.6	105.3	94.7	122.1	107.5	97.2
	SHC	54.3	63.3	75.0	58.0	69.4	83.8	60.4	73.4	89.1	65.2	81.7	97.0
	kW	7.35	7.26	7.17	7.41	7.31	7.24	7.43	7.33	7.24	7.46	7.37	7.28
95	TC	109.6	96.2	85.3	113.3	99.7	89.2	115.4	101.1	90.3	118.3	103.2	93.1
	SHC	52.9	61.9	73.1	56.5	67.9	81.7	59.1	71.9	87.3	64.0	80.3	93.1
	kW	8.37	8.27	8.16	8.42	8.33	8.24	8.46	8.34	8.22	8.51	8.40	8.31
105	TC	105.6	92.1	81.3	108.8	95.2	84.6	110.4	96.4	86.3	113.2	98.4	89.1
	SHC	51.4	60.4	71.6	55.2	66.4	80.0	57.5	70.3	85.3	62.5	78.3	89.1
	kW	9.49	9.37	9.27	9.55	9.44	9.34	9.57	9.45	9.35	9.61	9.49	9.41
115	TC	100.4	87.9	76.8	103.1	90.4	80.3	105.1	91.7	82.1	107.6	93.5	85.0
	SHC	49.4	58.6	69.6	52.9	64.7	78.3	55.8	68.5	81.9	60.6	76.6	85.0
	kW	10.63	10.56	10.46	10.70	10.62	10.55	10.74	10.62	10.54	10.80	10.68	10.58
125	TC	95.8	83.0	72.0	98.5	85.5	74.9	99.8	86.6	77.5	101.4	88.2	80.7
	SHC	48.0	56.8	67.5	51.6	62.9	74.9	54.0	66.9	77.5	58.2	74.6	80.7
	kW	11.97	11.83	11.61	12.02	11.89	11.73	12.05	11.92	11.80	12.09	11.97	11.86

LEGEND

- BF — Bypass Factor
- Edb — Entering Dry-Bulb
- Ewb — Entering Wet-Bulb
- kW — Compressor Motor Power Input
- Ldb — Leaving Dry-Bulb
- Lwb — Leaving Wet-Bulb
- SHC — Sensible Heat Capacity (1000 Btuh) Gross
- TC — Total Capacity (1000 Btuh) Gross

NOTES:

1. Direct interpolation is permissible. Do not extrapolate.
2. The following formulas may be used:

$$t_{ldb} = t_{edb} - \frac{\text{sensible capacity (Btuh)}}{1.10 \times \text{cfm}}$$

t_{lwb} = Wet-bulb temperature corresponding to enthalpy of air leaving evaporator coil (h_{lwb})

$$h_{lwb} = h_{ewb} - \frac{\text{total capacity (Btuh)}}{4.5 \times \text{cfm}}$$

Where: h_{ewb} = Enthalpy of air entering evaporator coil.

3. The SHC is based on 80 F edb temperature of air entering evaporator coil. Below 80 F edb, subtract (corr factor x cfm) from SHC. Above 80 F edb, add (corr factor x cfm) to SHC.

BYPASS FACTOR (BF)	ENTERING AIR DRY-BULB TEMP (F)					
	79	78	77	76	75	under 75
	81	82	83	84	85	over 85
Correction Factor						
.05	1.04	2.07	3.11	4.14	5.18	Use formula shown below.
.10	.98	1.96	2.94	3.92	4.90	
.20	.87	1.74	2.62	3.49	4.36	
.30	.76	1.53	2.29	3.05	3.82	

Interpolation is permissible.

Correction Factor = $1.10 \times (1 - BF) \times (edb - 80)$.

EXPANDED PERFORMANCE DATA (COOLING) 10 Ton (GROSS Capacity)

Airflow CFM IDB (BF)			Outdoor Ambient Temperature - Degrees F, Dry Bulb														
			75			85			95			105			115		
			Entering Indoor Air Temperature - Degrees F, Wet Bulb														
			62	67	72	62	67	72	62	67	72	62	67	72	62	67	72
80	4500 (0.15)	MBH	120.6	131.2	143.1	115.6	125.3	136.7	109.5	119.3	129.9	102.3	112.4	123.2	97.2	105.8	120.2
		S/T	0.97	0.75	0.53	0.98	0.76	0.54	0.99	0.79	0.55	1.00	0.82	0.56	1.00	0.85	0.57
		KW	7.66	7.93	8.27	8.21	8.48	8.82	8.79	9.07	9.38	9.45	9.68	10.00	9.75	9.94	10.28
	4000 (0.125)	MBH	118.7	129.4	141.1	113.4	123.8	134.7	105.9	117.8	128.3	97.6	110.8	121.6	92.5	102.8	118.9
		S/T	0.94	0.72	0.51	0.96	0.73	0.52	0.99	0.76	0.53	1.00	0.78	0.55	1.00	0.82	0.55
		KW	7.60	7.88	8.20	8.15	8.43	8.75	8.71	9.01	9.33	9.35	9.62	9.94	9.66	9.88	10.23
	3500 (0.095)	MBH	114.8	126.5	137.8	108.2	121.2	131.8	100.9	115.2	125.6	92.3	107.2	119.3	88.0	100.0	116.4
		S/T	0.91	0.69	0.50	0.93	0.70	0.51	0.96	0.72	0.52	0.98	0.75	0.53	1.00	0.78	0.53
		KW	7.53	7.79	8.10	8.07	8.34	8.64	8.62	8.92	9.23	9.23	9.53	9.86	9.50	9.79	10.14

FORMULAS AND NOTES FOR USING EXPANDED PERFORMANCE DATA

To find leaving wet bulb and dry bulb from the expanded performance charts, use the following formulas.

- Direct interpolation is permissible. Do not extrapolate.
- The following formulas may be used:
 $t/db = t\ edb - \text{sensible capacity Btuh} / (1.10 \times \text{cfm})$
 $t/wb = \text{Wet bulb temp. corresponding to enthalpy of air leaving evaporator coil (h/wb)}$
 $h/wb = h\ ewb - \text{total capacity Btuh} / (4.5 \times \text{cfm})$
 where h ewb = Enthalpy of air entering evap. coil
- The SHC is based on 80F edb of air entering evap coil. Below 80F edb, subtract (corr factor x cfm) from SHC. Above 80F edb, add (corr factor x cfm) to SHC.

LEGEND	
MBH	= Total Capacity (Gross)
S/T	= Sensible to Total Ratio
KW	= Compressor Motor Power Input.
IDB	= Indoor Dry Bulb
edb	= Entering Dry Bulb
ewb	= Entering Wet Bulb
t/db	= Leaving Dry Bulb
t/wb	= Leaving Wet Bulb
h/wb	= Enthalpy of Leaving Wet Bulb
SHC	= Sensible Heat Capacity

BYPASS FACTOR (BF)	ENTERING AIR DRY BULB					
	79	78	77	76	75	under 75
	81	82	83	84	85	over 85
	Correction Factor					
.05	1.04	2.07	3.11	4.14	5.18	Use formulas shown below
.10	0.98	1.96	2.94	3.92	4.90	
.20	0.87	1.74	2.62	3.49	4.36	
.30	0.76	1.53	2.29	3.05	3.82	

Correction Factor = 1.10 x (1-BF) x (edb-80).

EXPANDED PERFORMANCE DATA (COOLING) 12-1/2 Ton (GROSS Capacity)

Airflow CFM IDB (BF)			Outdoor Ambient Temperature - Degrees F, Dry Bulb														
			75			85			95			105			115		
			Entering Indoor Air Temperature - Degrees F, Wet Bulb														
			62	67	72	62	67	72	62	67	72	62	67	72	62	67	72
80	6250 (0.12)	MBH	151.0	162.0	173.9	147.1	156.8	169.5	142.3	150.9	164.0	136.7	143.7	156.4	128.1	133.2	148.4
		S/T	1.00	0.79	0.56	1.00	0.81	0.57	1.00	0.83	0.58	1.00	0.86	0.59	1.00	0.90	0.61
		KW	9.03	9.29	9.53	10.06	10.27	10.59	11.18	11.39	11.69	12.33	12.53	12.77	13.49	13.65	13.94
	5000 (0.10)	MBH	146.2	158.2	170.9	141.3	153.0	166.3	134.5	147.6	159.9	136.4	140.4	153.3	117.1	127.5	145.5
		S/T	0.96	0.73	0.52	0.97	0.75	0.53	0.99	0.76	0.54	0.93	0.79	0.55	1.00	0.83	0.56
		KW	8.93	9.19	9.46	9.96	10.17	10.51	11.03	11.30	11.57	12.14	12.43	12.72	13.30	13.52	13.84
	4500 (0.09)	MBH	142.6	155.3	167.3	137.4	150.2	162.6	129.3	144.6	157.2	119.1	137.2	150.7	109.1	119	142.1
		S/T	0.92	0.70	0.51	0.93	0.71	0.51	0.96	0.72	0.52	0.99	0.74	0.53	1.00	0.814	0.54
		KW	8.87	9.12	9.36	9.87	10.12	10.39	10.93	11.22	11.51	12.02	12.33	12.64	13.15	13.44	13.73
	3750 (0.08)	MBH	139.9	152.0	164.6	133.6	147.1	159.9	124.4	141.5	154.2	114.0	134.2	147.8	102.8	120.4	139.7
		S/T	0.87	0.67	0.49	0.89	0.68	0.50	0.92	0.69	0.51	0.96	0.71	0.51	1.00	0.75	0.52
		KW	8.82	9.04	9.30	9.82	10.03	10.33	10.84	11.13	11.43	11.91	12.23	12.57	13.02	13.35	13.64

FORMULAS AND NOTES FOR USING EXPANDED PERFORMANCE DATA

To find leaving wet bulb and dry bulb from the expanded performance charts, use the following formulas.

1. Direct interpolation is permissible. Do not extrapolate.

2. The following formulas may be used:

$$t/db = t\ edb - \text{sensible capacity Btuh} / (1.10 \times \text{cfm})$$

$$t/wb = \text{Wet bulb temp. corresponding to enthalpy of air leaving evaporator coil (h/wb)}$$

$$h/wb = h\ ewb - \text{total capacity Btuh} / (4.5 \times \text{cfm})$$

where h ewb = Enthalpy of air entering evap. coil

3. The SHC is based on 80F edb of air entering evap coil. Below 80F edb, subtract (corr factor x cfm) from SHC. Above 80F edb, add (corr factor x cfm) to SHC.

LEGEND	
MBH	= Total Capacity (Gross)
S/T	= Sensible to Total Ratio
KW	= Compressor Motor Power Input.
IDB	= Indoor Dry Bulb
edb	= Entering Dry Bulb
ewb	= Entering Wet Bulb
t/db	= Leaving Dry Bulb
t/wb	= Leaving Wet Bulb
h/wb	= Enthalpy of Leaving Wet Bulb
SHC	= Sensible Heat Capacity

BYPASS FACTOR (BF)	ENTERING AIR DRY BULB					
	79	78	77	76	75	under 75
	81	82	83	84	85	over 85
Correction Factor						
.05	1.04	2.07	3.11	4.14	5.18	Use formulas shown below
.10	0.98	1.96	2.94	3.92	4.90	
.20	0.87	1.74	2.62	3.49	4.36	
.30	0.76	1.53	2.29	3.05	3.82	

$$\text{Correction Factor} = 1.10 \times (1-BF) \times (\text{edb}-80).$$

CIRCULATING BLOWER PERFORMANCE - PGE072 - Standard Motor (Belt Drive)* (Horizontal Discharge)

Airflow CFM	EXTERNAL STATIC PRESSURE (in. wg)																			
	0.2		0.4		0.6		0.8		1.0		1.2		1.4		1.6		1.8		2.0	
	RPM	Watts	RPM	Watts	RPM	Watts	RPM	Watts	RPM	Watts	RPM	Watts	RPM	Watts	RPM	Watts	RPM	Watts	RPM	Watts
1800	919	561	1010	663	1095	771	1174	886	1250	1008	1321	1137	1390	1273	1455	1415	1518	1563	1579	1718
1900	960	648	1047	754	1129	867	1206	986	1279	1111	1348	1243	1415	1381	1479	1526	1541	1677	1601	1834
2000	1001	744	1085	855	1163	972	1238	1095	1309	1224	1377	1359	1442	1500	1505	1648	1565	1801	1624	1961
2100	1043	850	1123	965	1199	1086	1271	1213	1340	1346	1406	1485	1470	1629	1531	1780	1591	1936	1648	2098
2200	1085	966	1162	1086	1235	1211	1305	1342	1372	1479	1437	1621	1499	1769	1559	1923	1617	2082	-	-
2300	1127	1092	1201	1217	1272	1347	1340	1482	1405	1623	1468	1769	1529	1920	1587	2077	-	-	-	-
2400	1169	1229	1241	1359	1310	1493	1375	1633	1439	1778	1500	1928	1559	2083	-	-	-	-	-	-
2500	1212	1378	1281	1513	1348	1652	1412	1796	1473	1945	1533	2098	-	-	-	-	-	-	-	-
2600	1255	1539	1322	1678	1386	1822	1448	1970	1508	2124	-	-	-	-	-	-	-	-	-	-
2700	1298	1713	1363	1857	1425	2005	-	-	-	-	-	-	-	-	-	-	-	-	-	-
2800	1341	1899	1404	2048	-	-	-	-	-	-	-	-	-	-	-	-	-	-	-	-
2900	1384	2099	-	-	-	-	-	-	-	-	-	-	-	-	-	-	-	-	-	-
3000	-	-	-	-	-	-	-	-	-	-	-	-	-	-	-	-	-	-	-	-

LEGEND

Watts = Input Watts to motor.

* Motor drive range: 1070 to 1460 rpm. All other rpms require a field-supplied drive.

Maximum continuous bhp is 2.40.

CIRCULATING BLOWER PERFORMANCE - PGE090 - Standard Motor (Belt Drive)* (Horizontal Discharge)

Airflow CFM	EXTERNAL STATIC PRESSURE (in. wg)																			
	0.2		0.4		0.6		0.8		1.0		1.2		1.4		1.6		1.8		2.0	
	RPM	Watts	RPM	Watts	RPM	Watts	RPM	Watts	RPM	Watts	RPM	Watts	RPM	Watts	RPM	Watts	RPM	Watts	RPM	Watts
2250	505	484	586	681	657	901	722	1142	782	1403	838	1683	891	1981	-	-	-	-	-	-
2300	513	509	592	708	663	931	727	1174	787	1437	842	1719	895	2019	-	-	-	-	-	-
2400	528	561	605	766	675	993	738	1241	796	1508	851	1793	903	2097	-	-	-	-	-	-
2500	543	617	618	828	686	1060	748	1312	806	1583	860	1873	911	2180	-	-	-	-	-	-
2550	550	647	625	860	692	1095	754	1349	811	1623	865	1914	916	2223	-	-	-	-	-	-
2600	558	677	632	894	698	1131	759	1388	816	1664	869	1957	-	-	-	-	-	-	-	-
2700	574	742	646	964	711	1207	770	1469	826	1749	879	2046	-	-	-	-	-	-	-	-
2800	589	811	660	1039	723	1287	782	1554	837	1839	889	2140	-	-	-	-	-	-	-	-
2900	605	885	674	1119	736	1372	794	1644	848	1933	899	2239	-	-	-	-	-	-	-	-
3000	621	963	688	1204	749	1463	806	1740	859	2033	-	-	-	-	-	-	-	-	-	-
3100	637	1046	702	1293	763	1558	818	1840	871	2139	-	-	-	-	-	-	-	-	-	-
3200	653	1135	717	1388	776	1658	831	1946	-	-	-	-	-	-	-	-	-	-	-	-
3300	670	1228	732	1488	789	1764	843	2057	-	-	-	-	-	-	-	-	-	-	-	-
3400	686	1328	747	1593	803	1876	856	2174	-	-	-	-	-	-	-	-	-	-	-	-
3500	703	1433	762	1705	817	1993	-	-	-	-	-	-	-	-	-	-	-	-	-	-
3600	719	1543	777	1822	832	2116	-	-	-	-	-	-	-	-	-	-	-	-	-	-
3700	736	1660	793	1944	-	-	-	-	-	-	-	-	-	-	-	-	-	-	-	-
3750	745	1721	801	2008	-	-	-	-	-	-	-	-	-	-	-	-	-	-	-	-

LEGEND

Watts = Input Watts to motor.

* Motor drive range: 590 to 840 rpm. All other rpms require a field-supplied drive.

Maximum continuous bhp is 2.40.

CIRCULATING BLOWER PERFORMANCE - PGE102 - Standard Motor (Belt Drive) (Horizontal Discharge)																					
Airflow CFM		EXTERNAL STATIC PRESSURE (in. wg)																			
		0.2		0.4		0.6		0.8		1.0		1.2		1.4		1.6		1.8		2.0	
		RPM	Watts	RPM	Watts	RPM	Watts	RPM	Watts	RPM	Watts	RPM	Watts	RPM	Watts	RPM	Watts	RPM	Watts	RPM	Watts
2550	550	647	625	860	692	1095	754	1349	811	1623	865	1914	916	2223	-	-	-	-	-	-	
2600	558	677	632	894	698	1131	760	1388	816	1664	869	1957	-	-	-	-	-	-	-	-	
2700	574	742	646	964	710	1207	770	1469	826	1749	879	2046	-	-	-	-	-	-	-	-	
2800	589	811	660	1039	723	1287	782	1554	837	1839	889	2140	-	-	-	-	-	-	-	-	
2900	605	885	673	1119	736	1372	794	1644	848	1933	899	2239	-	-	-	-	-	-	-	-	
3000	621	963	688	1204	749	1463	806	1740	859	2033	-	-	-	-	-	-	-	-	-	-	
3100	637	1046	702	1293	763	1558	819	1840	871	2139	-	-	-	-	-	-	-	-	-	-	
3200	653	1135	717	1388	776	1658	831	1946	-	-	-	-	-	-	-	-	-	-	-	-	
3300	670	1228	732	1488	790	1764	843	2057	-	-	-	-	-	-	-	-	-	-	-	-	
3400	686	1328	747	1593	803	1876	856	2174	-	-	-	-	-	-	-	-	-	-	-	-	
3500	703	1433	762	1705	817	1993	-	-	-	-	-	-	-	-	-	-	-	-	-	-	
3600	719	1543	777	1822	832	2116	-	-	-	-	-	-	-	-	-	-	-	-	-	-	
3700	736	1660	793	1944	-	-	-	-	-	-	-	-	-	-	-	-	-	-	-	-	
3750	744	1721	801	2008	-	-	-	-	-	-	-	-	-	-	-	-	-	-	-	-	
3800	753	1783	808	2074	-	-	-	-	-	-	-	-	-	-	-	-	-	-	-	-	
3900	770	1912	824	2209	-	-	-	-	-	-	-	-	-	-	-	-	-	-	-	-	
4000	787	2047	-	-	-	-	-	-	-	-	-	-	-	-	-	-	-	-	-	-	
4100	804	2189	-	-	-	-	-	-	-	-	-	-	-	-	-	-	-	-	-	-	
4200	-	-	-	-	-	-	-	-	-	-	-	-	-	-	-	-	-	-	-	-	

LEGEND

Watts = Input Watts to motor.

* Motor drive range: 685 to 935 rpm. All other rpms require a field-supplied drive.

Maximum continuous bhp is 2.40.

CIRCULATING BLOWER PERFORMANCE - PGE120 - Standard Motor (Belt Drive) (Horizontal Discharge)																					
Airflow CFM		EXTERNAL STATIC PRESSURE (in. wg)																			
		0.2		0.4		0.6		0.8		1.0		1.2		1.4		1.6		1.8		2.0	
		RPM	Watts	RPM	Watts	RPM	Watts	RPM	Watts	RPM	Watts	RPM	Watts	RPM	Watts	RPM	Watts	RPM	Watts	RPM	Watts
3000	555	630	629	765	696	904	757	1048	814	1198	867	1353	918	1513	966	1680	1012	1852	1056	2029	
3100	568	686	641	825	706	968	766	1115	823	1269	876	1427	926	1590	973	1760	1019	1934	-	-	
3200	582	745	652	888	717	1035	776	1186	832	1343	884	1504	934	1671	981	1843	1026	2020	-	-	
3300	595	808	664	955	728	1106	786	1261	841	1421	893	1586	942	1755	988	1930	1033	2111	-	-	
3400	609	874	677	1026	739	1181	797	1340	851	1503	902	1671	950	1844	996	2022	-	-	-	-	
3500	623	945	689	1100	750	1259	807	1422	860	1589	911	1760	959	1937	-	-	-	-	-	-	
3600	636	1019	702	1179	762	1341	817	1508	870	1679	920	1854	967	2033	-	-	-	-	-	-	
3700	650	1097	714	1261	773	1428	828	1598	880	1772	929	1951	-	-	-	-	-	-	-	-	
3800	664	1179	727	1347	785	1518	839	1693	890	1870	939	2053	-	-	-	-	-	-	-	-	
3900	678	1266	740	1438	797	1613	850	1791	901	1973	-	-	-	-	-	-	-	-	-	-	
4000	693	1356	753	1533	809	1712	861	1894	911	2080	-	-	-	-	-	-	-	-	-	-	
4100	707	1451	766	1632	821	1816	873	2002	-	-	-	-	-	-	-	-	-	-	-	-	
4200	721	1551	779	1736	833	1924	-	-	-	-	-	-	-	-	-	-	-	-	-	-	
4300	735	1656	792	1845	846	2037	-	-	-	-	-	-	-	-	-	-	-	-	-	-	
4400	750	1764	806	1958	-	-	-	-	-	-	-	-	-	-	-	-	-	-	-	-	
4500	764	1879	819	2077	-	-	-	-	-	-	-	-	-	-	-	-	-	-	-	-	
4600	779	1998	-	-	-	-	-	-	-	-	-	-	-	-	-	-	-	-	-	-	
4700	-	-	-	-	-	-	-	-	-	-	-	-	-	-	-	-	-	-	-	-	
4800	-	-	-	-	-	-	-	-	-	-	-	-	-	-	-	-	-	-	-	-	
4900	-	-	-	-	-	-	-	-	-	-	-	-	-	-	-	-	-	-	-	-	
5000	-	-	-	-	-	-	-	-	-	-	-	-	-	-	-	-	-	-	-	-	

LEGEND

Watts = Input Watts to motor.

* Motor drive range: 685 to 935 rpm. All other rpms require a field-supplied drive.

Maximum continuous bhp is 2.40.

CIRCULATING BLOWER PERFORMANCE - PGE150 - Standard Motor (Belt Drive) (Horizontal Discharge)

Airflow CFM	EXTERNAL STATIC PRESSURE (in. wg)																			
	0.2		0.4		0.6		0.8		1.0		1.2		1.4		1.6		1.8		2.0	
	RPM	Watts	RPM	Watts	RPM	Watts	RPM	Watts	RPM	Watts	RPM	Watts	RPM	Watts	RPM	Watts	RPM	Watts	RPM	Watts
3700	676	1106	747	1328	811	1552	871	1779	927	2008	981	2240	1031	2473	1079	2709	1125	2948	1169	3189
3800	690	1185	760	1414	823	1644	882	1876	938	2111	990	2348	1040	2587	1088	2828	1133	3073	1170	3319
3900	705	1269	773	1503	835	1739	894	1977	948	2217	1000	2459	1050	2705	1097	2951	1142	3201	1186	3452
4000	719	1357	786	1597	848	1838	905	2082	959	2328	1011	2576	1059	2826	1106	3079	1151	3334	-	-
4100	734	1449	799	1695	860	1942	917	2192	970	2443	1021	2697	1069	2953	1116	3210	-	-	-	-
4200	748	1545	813	1797	872	2050	928	2305	981	2562	1031	2822	1079	3083	1125	3347	-	-	-	-
4300	763	1646	826	1903	885	2162	940	2423	992	2686	1042	2951	1089	3218	-	-	-	-	-	-
4400	778	1751	840	2014	898	2279	952	2546	1004	2814	1053	3085	1100	3357	-	-	-	-	-	-
4500	792	1860	853	2130	910	2401	964	2673	1015	2947	1064	3224	-	-	-	-	-	-	-	-
4600	807	1975	867	2250	923	2527	976	2805	1027	3085	1075	3367	-	-	-	-	-	-	-	-
4700	822	2094	881	2375	936	2658	989	2942	1038	3227	-	-	-	-	-	-	-	-	-	-
4800	837	2218	895	2505	949	2794	1001	3093	1050	3375	-	-	-	-	-	-	-	-	-	-
4900	852	2347	909	2640	963	2935	1014	3230	-	-	-	-	-	-	-	-	-	-	-	-
5000	867	2482	923	2781	976	3081	1026	3383	-	-	-	-	-	-	-	-	-	-	-	-
5100	882	2622	937	2926	989	3232	-	-	-	-	-	-	-	-	-	-	-	-	-	-
5200	897	2766	951	3077	1003	3389	-	-	-	-	-	-	-	-	-	-	-	-	-	-
5300	912	2917	966	3233	-	-	-	-	-	-	-	-	-	-	-	-	-	-	-	-
5400	927	3073	980	3395	-	-	-	-	-	-	-	-	-	-	-	-	-	-	-	-
5500	943	3234	-	-	-	-	-	-	-	-	-	-	-	-	-	-	-	-	-	-
5600	958	3402	-	-	-	-	-	-	-	-	-	-	-	-	-	-	-	-	-	-

LEGEND

Watts = Input Watts to motor.

* Motor drive range: 860 to 1080 rpm. All other rpms require a field-supplied drive.

Maximum continuous bhp is 3.70.

Altitude Derating Factor*	
Elevation (ft.)	Maximum Heating Value (Btu/ft ³)
0 – 2000	1100
2001 – 3000	1050
3001 – 4000	1000
4001 – 5000	950
5001 – 6000	900

* Derating of the unit is not required unless the heating value of the gas exceeds the values listed in the table above, or if the elevation exceeds 6000 ft. Derating conditions must be 4% per thousand ft. above sea level. For example at 4000 ft. If the heating value of the gas exceeds 1000 Btu/ft³, the unit will require a 16% derating. For elevations above 6000 ft., the same formula applies. For example, at 7000 ft., the unit will require a 28% derating of the maximum heating value per the National Fuel Gas Code.

PGE Series PERFORMANCE DATA (CONT.)

Evaporator-Fan Motor Efficiency	
Unit PGE	Motor Efficiency (%)
072	84
090	80
102	80
120/150	85

All indoor-fan motors 5 hp and larger meet the minimum efficiency requirements as established by the Energy Policy Act of 1992 (EPACT) effective October 24, 1997.

EVAPORATOR-FAN MOTOR PERFORMANCE

Unit PGE	Evaporator-Fan Motor	Unit Voltage	Max. Acceptable Continuous BHP*	Max. Acceptable Operating Watts	Max. AMP Draw
072	Standard	208/230	2.40	2120	5.2
		460			3.0
		575			3.0
090	Standard	208/230	2.40	2120	6.7
		460			3.0
		575			3.0
102	Standard	208/230	2.40	2120	6.7
		460			3.0
		575			3.0
120	Standard	208/230	2.40	2120	6.7
		460			3.0
		575			3.0
150	Standard	208/230	3.70	3313	12.2
		460			5.5
		575			5.5

LEGEND

BHP = Brake Horsepower

* Extensive motor and electrical testing on these units ensures that the full horsepower range of the motors can be utilized with

confidence. Using your fan motors up to the horsepower ratings shown in this table will not result in nuisance tripping or premature motor failure. Unit Warranty will not be affected.

FAN RPM MOTOR PULLEY SETTINGS

Unit PGE	MOTOR PULLEY TURNS OPEN												
	0	1/2	1	1-1/2	2	2-1/2	3	3-1/2	4	4-1/2	5	5-1/2	6
072	1460	1421	1382	1343	1304	1265	1226	1187	1148	1109	1070	-	-
090	840	815	790	765	740	715	690	665	635	615	590	-	-
102	935	910	885	860	835	810	785	760	735	710	685	-	-
120	935	910	885	860	835	810	785	760	735	710	685	-	-
150	1080	1060	1035	1015	990	970	950	925	905	880	860	-	-

* Approximate fan rpm shown.

TYPICAL INSTALLATIONS

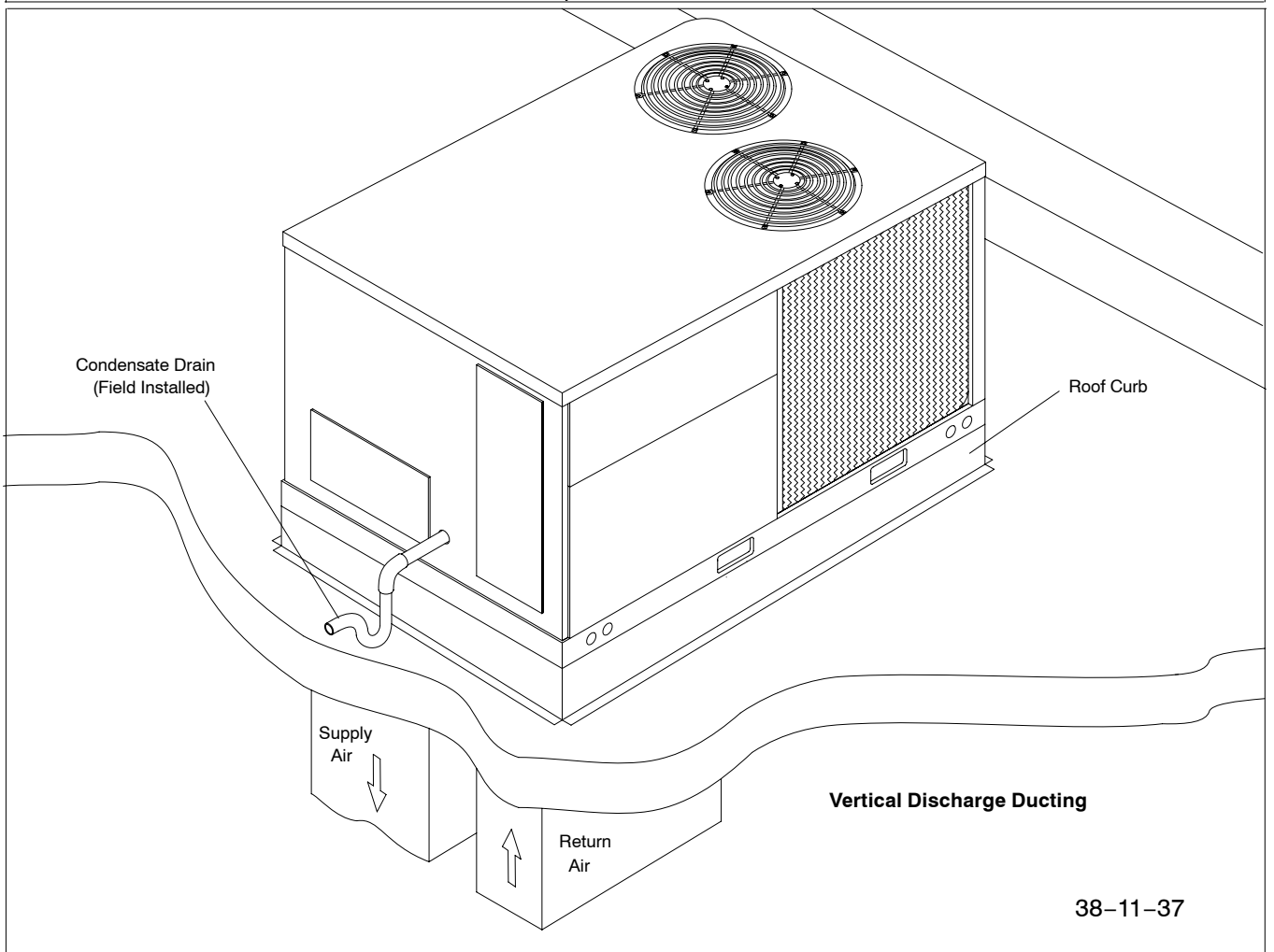
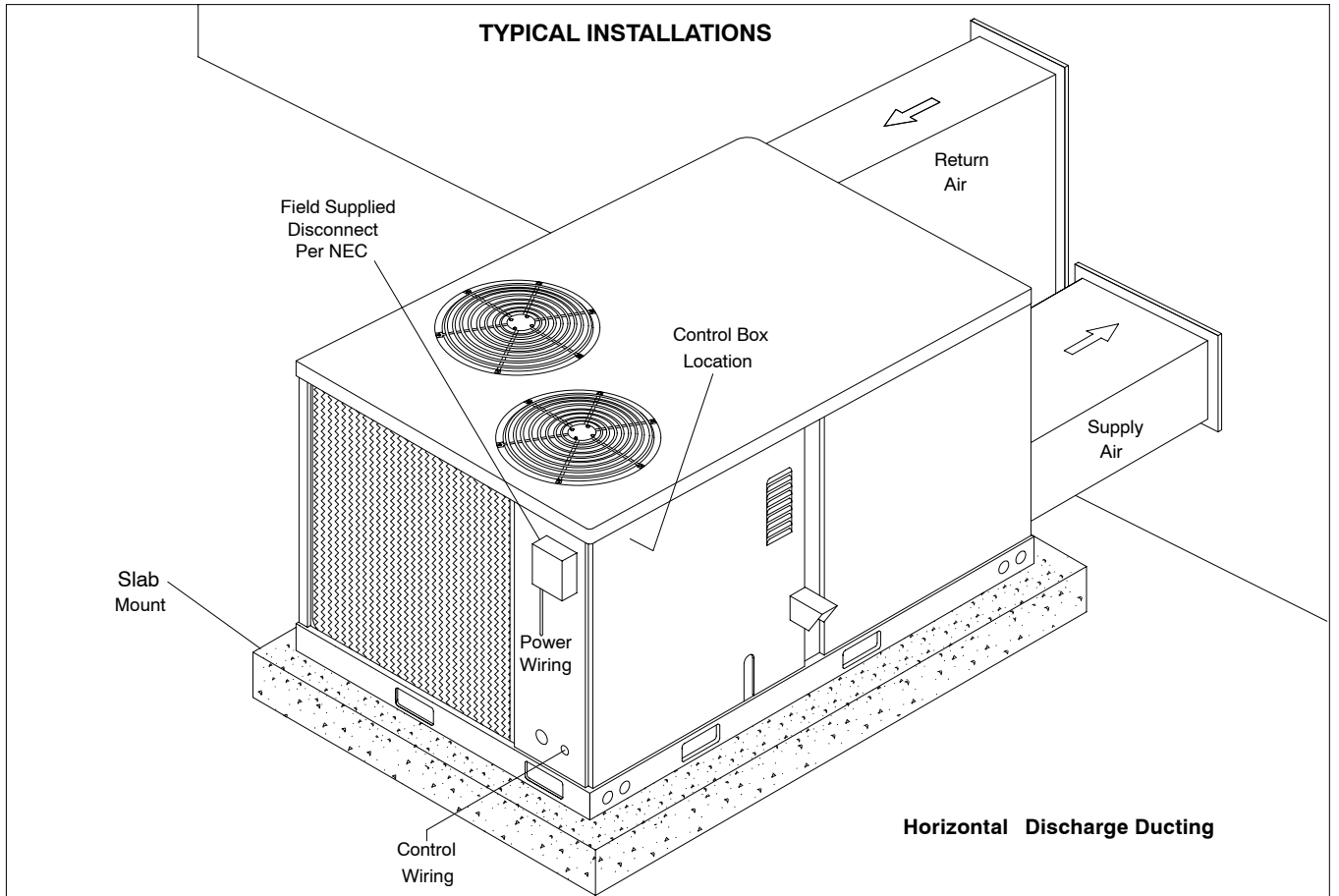

38-11-37

ACCESSORIES – PGE072

ROOF CURBS

Description	Model Number	Where Used
8" High *	AXB035CLA	072
14" High *	AXB035CMA	072
24" High *	AXB035CHA	072

CURB ADAPTOR

Description	Model Number	Where Used *
Curb Adaptor	AXB035CAA	072
Curb Adaptor With Duct	AXB035CBA	072

* Used with AXB030 curbs

Roof Opening
35" Long
40" Wide

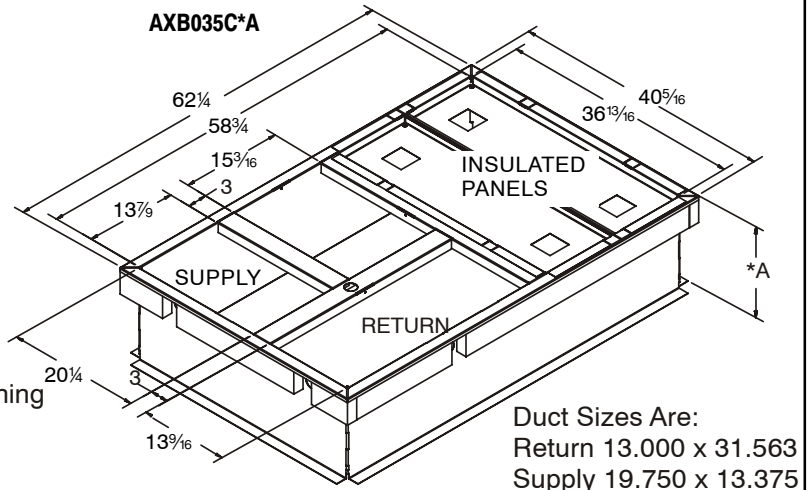

ECONOMIZER – DOWNFLOW

Description	Model Number	Where Used
Fully Modulating	AXB035EMA	072
Three Position	AXB035EPA	072

AXB035E*A

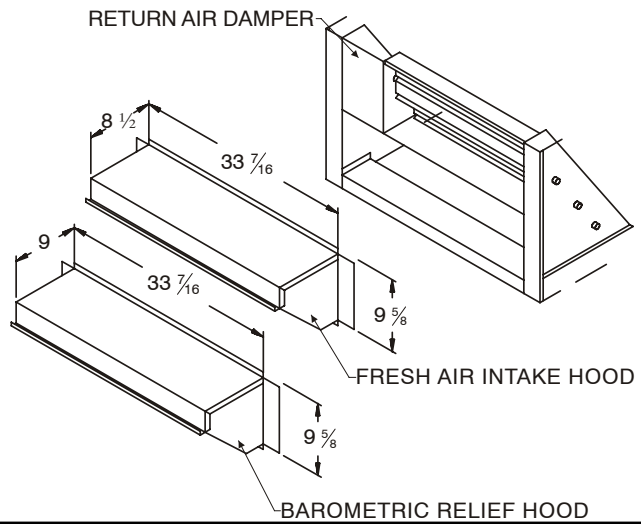

ECONOMIZER – HORIZONTAL

Description	Model Number	Where Used
Fully Modulating	AXB035HEA	072
Three Position	AXB035HPA	072

AXB035H*A

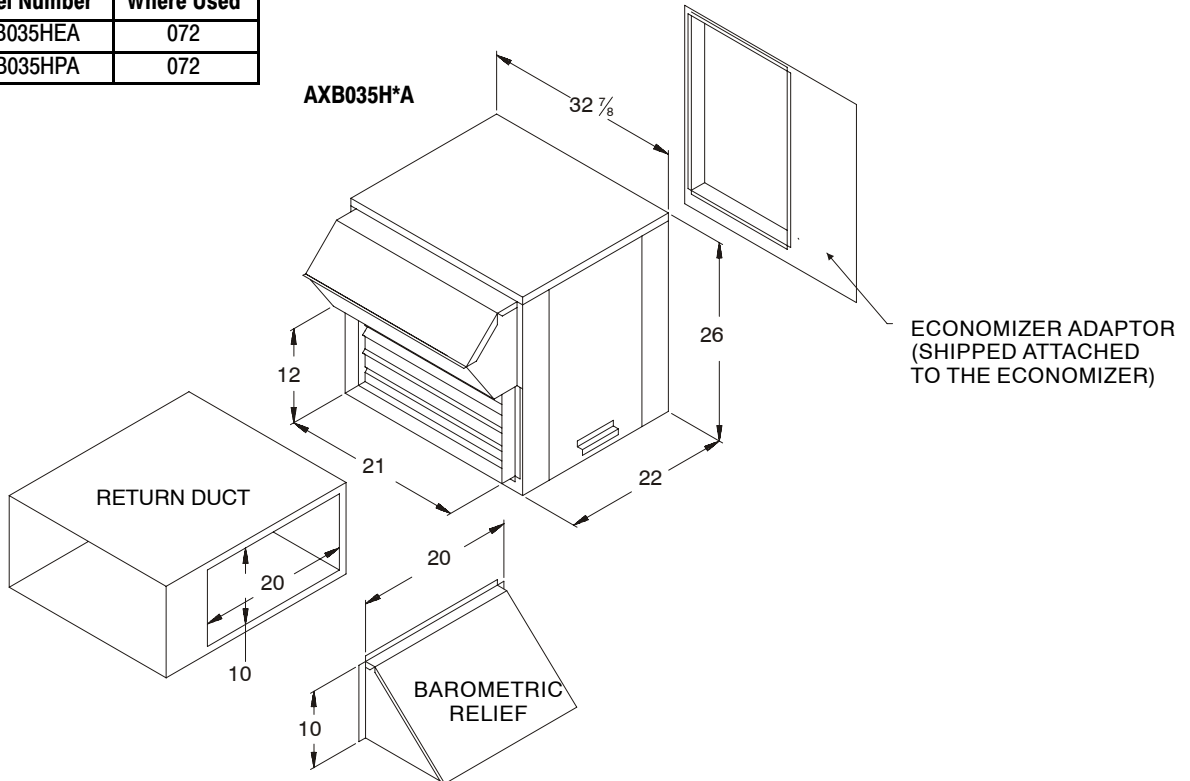

ACCESSORIES: PGE072 (CONT.)

FRESH AIR DAMPER

Description	Model Number	Where Used
Manual	AXB035FAA	072
Motorized	AXB035FMA	072

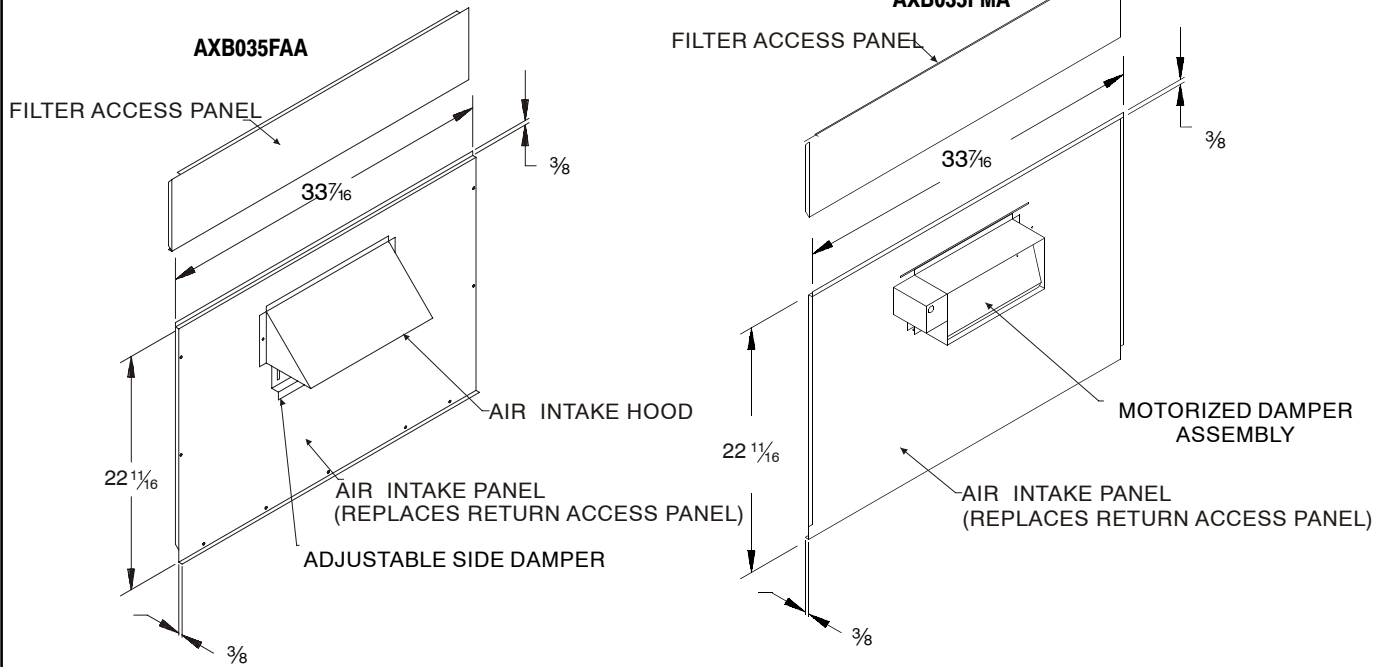

COIL PROTECTION

Description	Model Number	Where Used
Coil Guard	AXB035CGA	072
Hail Guard	AXB035HGA	072

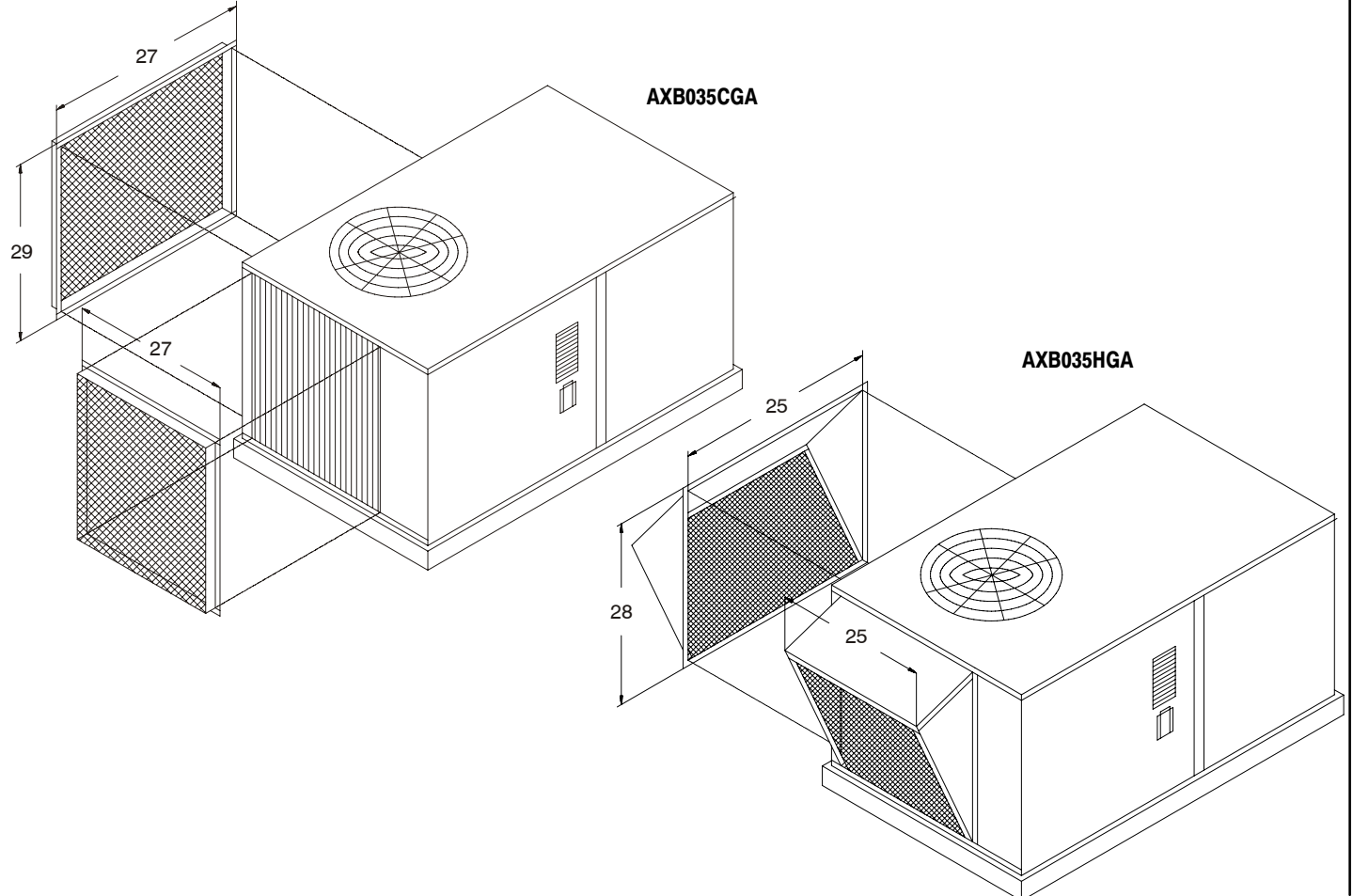

ACCESSORIES: PGE072 (CONT.)

CONCENTRIC DUCT KIT

Description	Model Number	Where Used
20" Round.	AXB035CTA	072

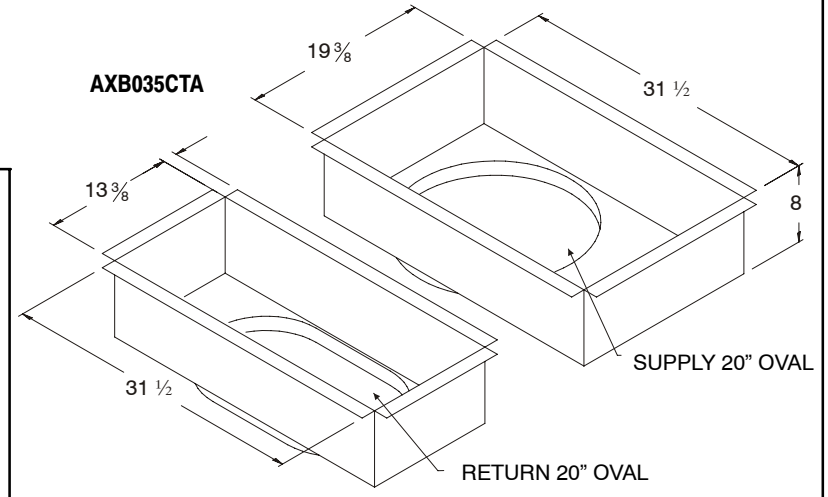

PERFORMANCE DATA ON NEXT PAGE

CONCENTRIC DIFFUSER

Description	Model Number	Used With
Flush Mount	AXB030CFA	072
Flush Mount	AXB040CFA	072
Step Down	AXB030CSA	072
Step Down	AXB040CSA	072

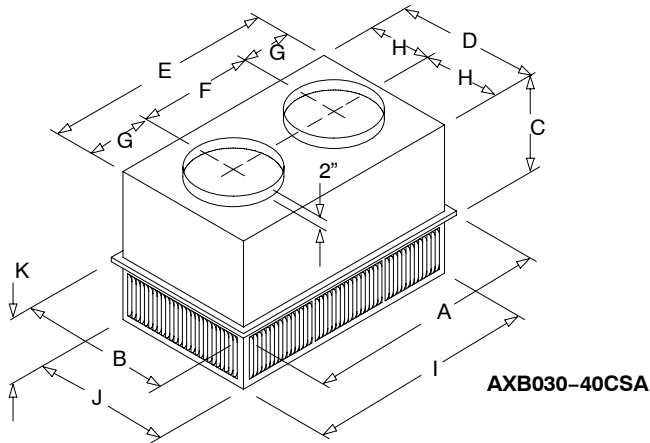

CONCENTRIC DIFFUSER (Step Down)

Model Number	A	B	C	D	E	F	G	H	I	J	K	Duct Size
AXB030CSA	47-5/8	23-5/8	11-3/8	21-1/2	45-1/2	22-1/2	11-1/2	10-3/4	45-1/2	21-1/2	7-1/8	18" RD
AXB040CSA	47-5/8	29-5/8	14-3/8	27-1/2	45-1/2	22-1/2	11-1/2	13-3/4	45-1/2	27-1/2	8-1/8	20" RD

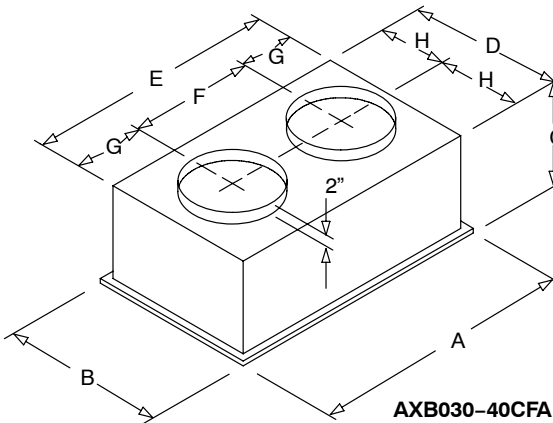

CONCENTRIC DIFFUSER (Flush Mount)

Model Number	A	B	C	D	E	F	G	H	Duct Size
AXB030CFA	47-5/8	23-5/8	13-1/2	21	45	22-1/2	11-1/4	10-1/2	18" RD
AXB040CFA	47-5/8	29-5/8	16-5/8	27	45	22-1/2	11-1/4	13-1/2	20" RD

ACCESSORIES: PGE072 (CONT.)

CSA SERIES STEP-DOWN PERFORMANCE					
Part No. AXB	CFM	Static Pressure In. WC	Throw Feet	Neck / Jet Velocity FPM	db Sound Levels
030CSA	1200	.17	11-18	421	20
	1400	.20	12-19	491	20
	1600	.24	12-20	561	20
	1800	.30	13-21	632	20
	2000	.36	14-23	702	20
	2200	.40	16-25	772	20
040CSA	2600	.17	24-29	669	20
	2800	.20	25-30	720	25
	3000	.25	27-33	772	25
	3200	.31	28-35	823	25
	3400	.37	30-37	874	30

CFA SERIES FLUSH MOUNT PERFORMANCE						
Part No. AXB	CFM	Static Pressure In. WC	Throw Feet	Neck Velocity FPM	Jet Velocity FPM	db Sound Level
030CFA	1000	.14	15-20	391	694	20
	1200	.17	16-22	469	833	25
	1400	.20	17-24	547	972	30
	1600	.24	18-25	625	1111	30
	1800	.30	20-28	703	1250	35
	2000	.36	21-29	781	1389	40
	2200	.40	22-30	859	1528	40
	040CFA	2600	.17	19-24	663	1294
2800		.20	20-28	714	1393	35
3000		.25	21-29	765	1492	35
3200		.31	22-29	816	1592	40
3400		.37	22-30	867	1692	40

CSA/CFA NOTES:

1. All data is based on the Air Diffusion Council guidelines.
2. Throw data is based on Terminal Velocities of 75 FPM using isothermal air.
3. Throw is based on diffuser blades being directed in a straight pattern.
4. Actual sound levels are less than those shown.
5. Minimum height 9' above floor.

NATURAL TO LP CONVERSION KIT	
Model Number *	Used With
AXB035LPA (1175706)	072
LOW AMBIENT KIT	
Model Number	Used With
AXB035LAA	072
THRU-THE-BASE POWER KIT	
Model Number	Used With
AXB035PKA	072

* Available thru service parts only

ACCESSORIES: PGE072 (CONT.)

POWER EXHAUST

Description	Model Number	Where Used
208/230 Volt	AXB035PEH	072
460 Volt	AXB035PEL	072
575 Volt	AXB035PES	072

POWER EXHAUST PERFORMANCE DATA

Model	Volt/Phase/ Hertz	Motor			Unit									
		Qty	HP	RPM	Cir. Qty	LRA	FLA	MCA	Fuse Size	@0.0		@0.3		
										CFM	RPM	CFM	RPM	
AXB035PEH	208-230/1/60	1	1	1725	1	10.2	4.3	5.4	10	2400	1725	2100	1725	
AXB035PEL	460/1/60	1	1	1625	1	4.1	1.7	2.2	4	2300	625	2000	1625	
AXB035PES	575/1/60	1	1	1625	1	4.1	1.7	2.2	4	2300	1625	2000	1625	

NOTE: Power exhaust is wired single phase, drop third leg when installing.

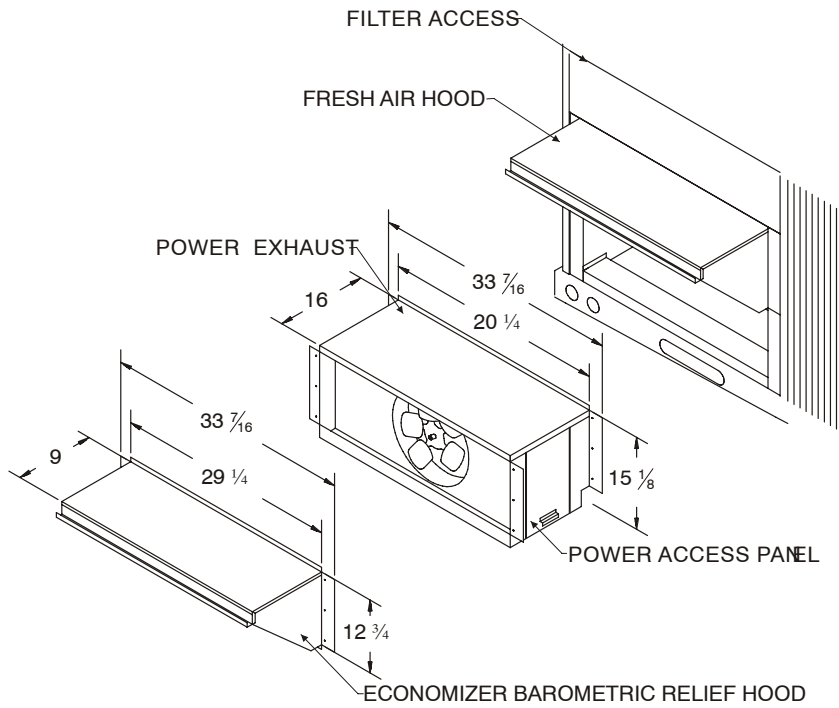

ACCESSORIES: PGE090 – 150

ROOF CURBS

Description	Model Number	Where Used
8" High *	AXB045CLA	090, 102, 120, 150
14" High *	AXB045CMA	090, 102, 120, 150
24" High *	AXB045CHA	090, 102, 120, 150

* A Dimension

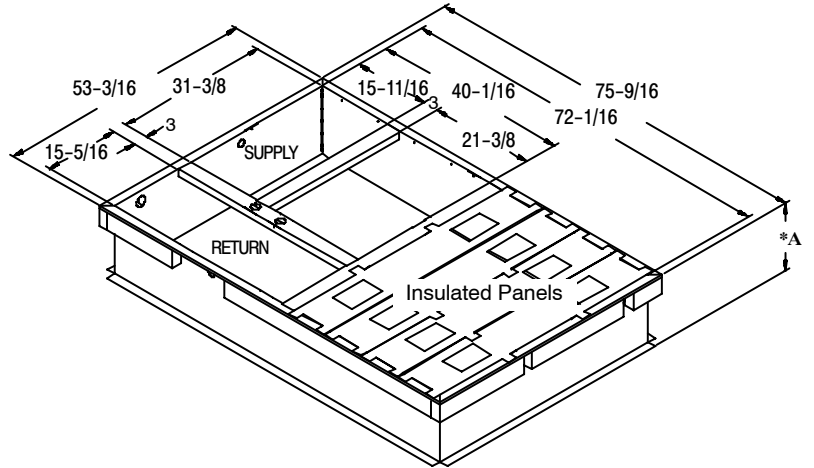

ECONOMIZER – DOWNFLOW

Description	Model Number	A Dimension	B Dimension	Where Used
Fully Modulating	AXB145EMA	13-3/4"	12-3/4"	090, 102
	AXB245EMA	16-1/2"	17-3/4"	120, 150
Three Position	AXB145EPA	13-3/4"	12-3/4"	090, 102
	AXB245EPA	16-1/2"	17-3/4"	120, 150

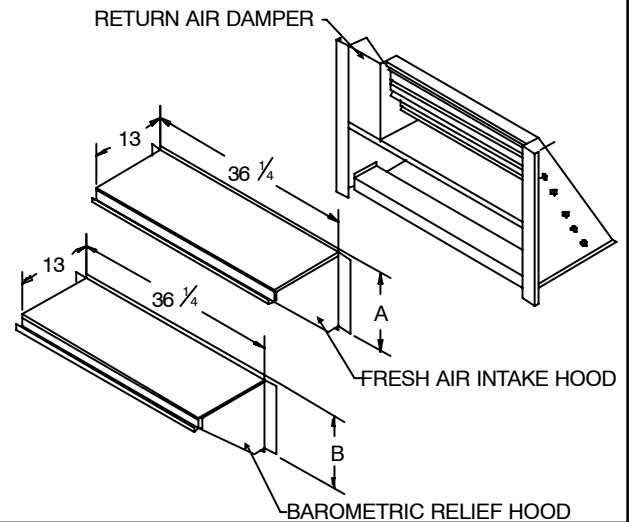

ECONOMIZER – HORIZONTAL

Description	Model Number	Where Used
Fully Modulating	AXB145HEA	090, 102
	AXB245HEA	120, 150
Three Position	AXB145HPA	090, 102
	AXB245HPA	120, 150

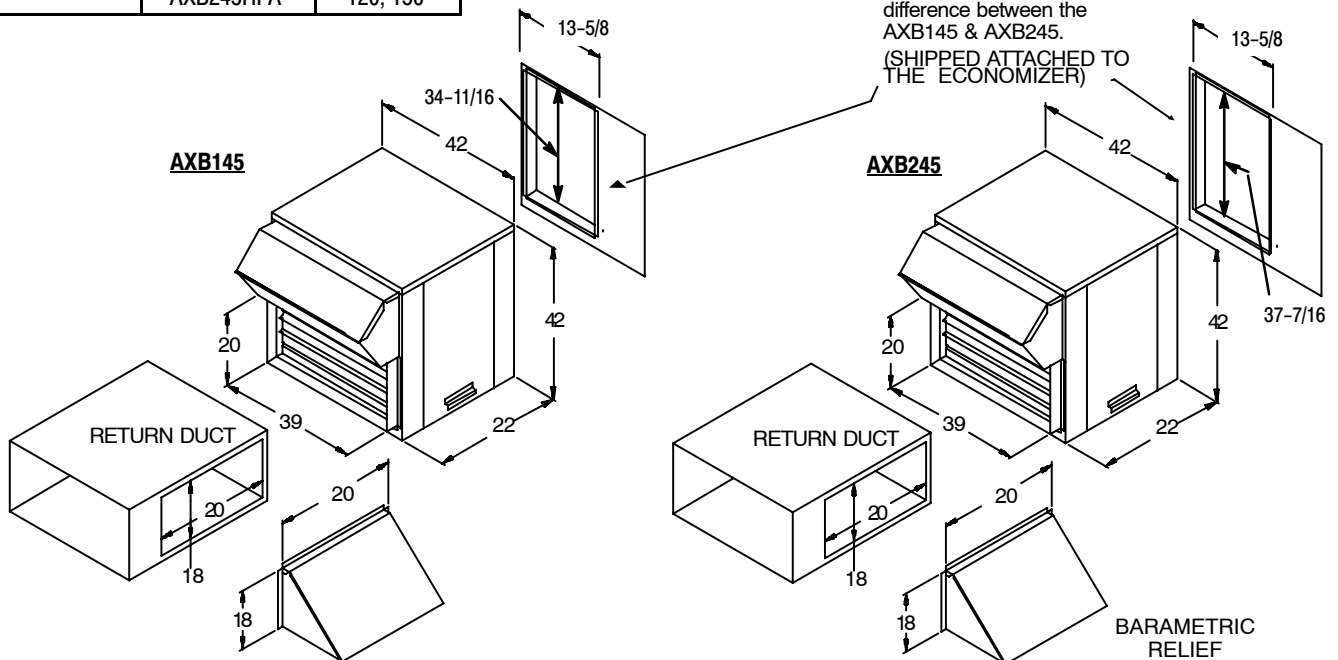

ACCESSORIES: PGE090 – 150 (CONT.)

FRESH AIR DAMPER

Description	Model Number	A Dimension	Where Used
Manual	AXB145FAA	27-15/16	90, 102
	AXB245FAA	32-1/2	120, 150
Motorized	AXB145FMA	27-15/16	090, 102
	AXB245FMA	32-1/2	120, 150

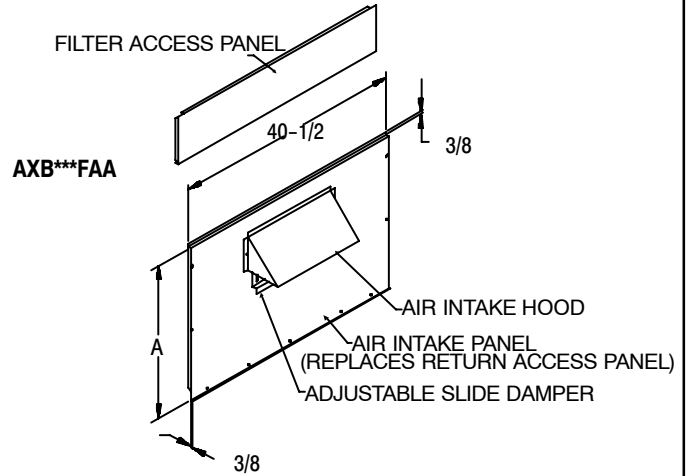
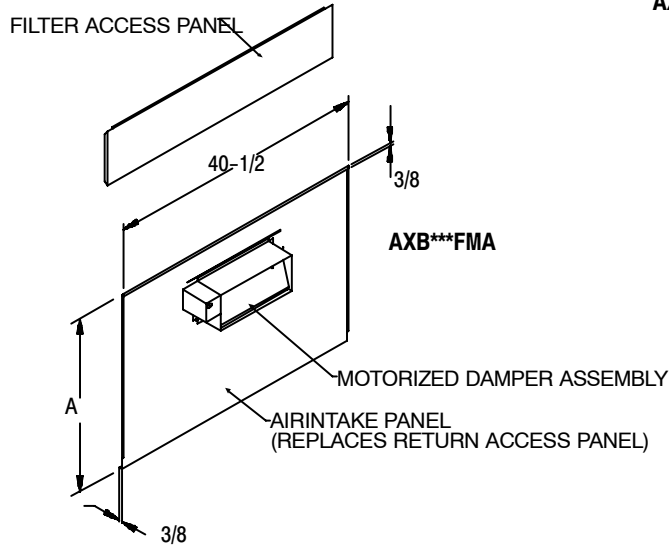

COIL PROTECTION

DIMENSIONS

Description	Model Number	Where Used	A	B
Coil Guard	AXB145CGA	090, 102	44	37
	AXB245CGA	120, 150	45-3/8	45
Hail Guard	AXB145HGA	090, 102	42	36
	AXB245HGA	120, 150	43-3/8	44

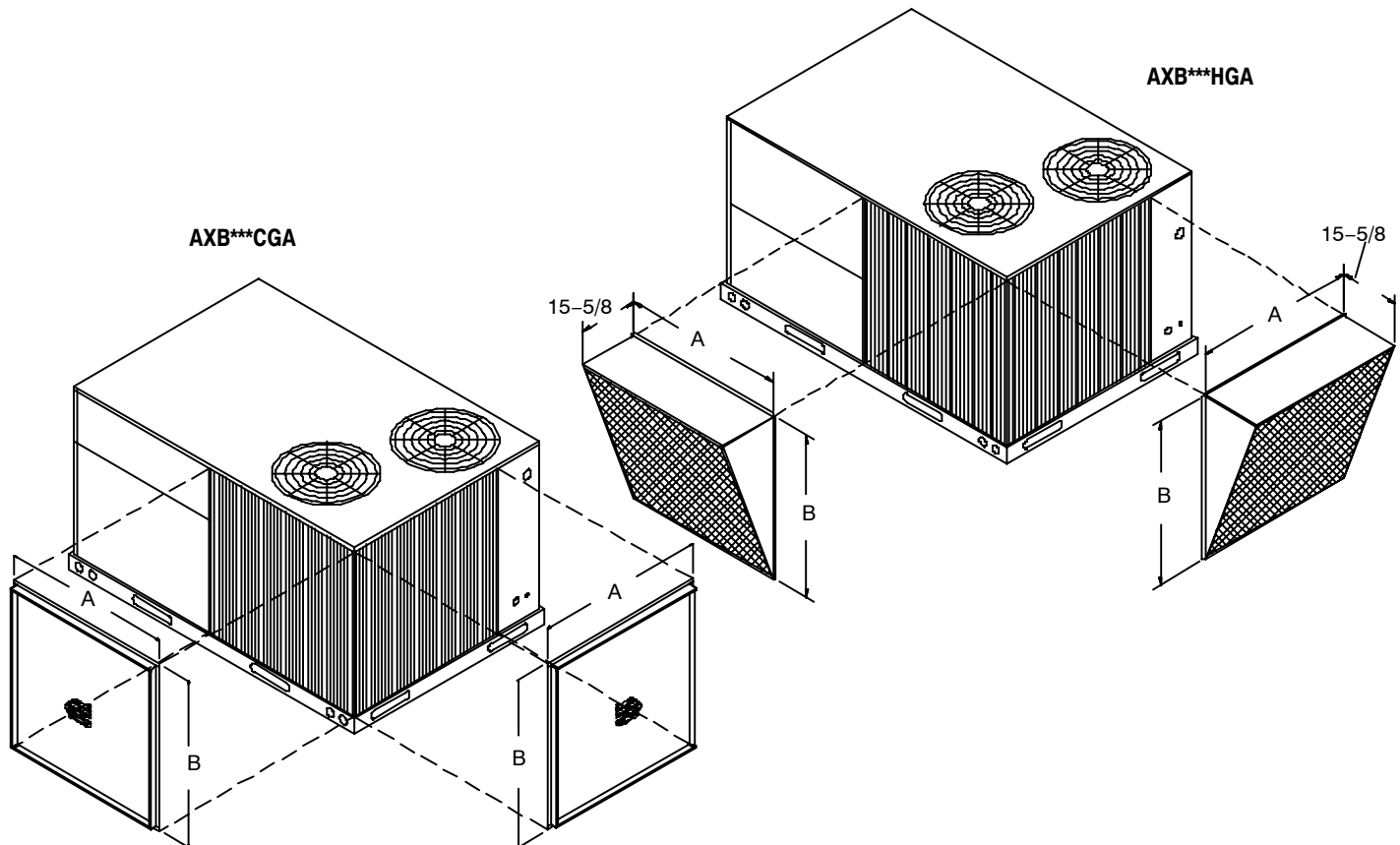

ACCESSORIES: PGE090 – 150 (CONT.)

CONCENTRIC DUCT KIT

Description	Model Number	Where Used
20" Round	AXB445CTA	090, 102
18" x 28" Rect.	AXB545CTA	120
18" x 32" Rect.	AXB645CTA	150

AXB445CTA
SHOWN

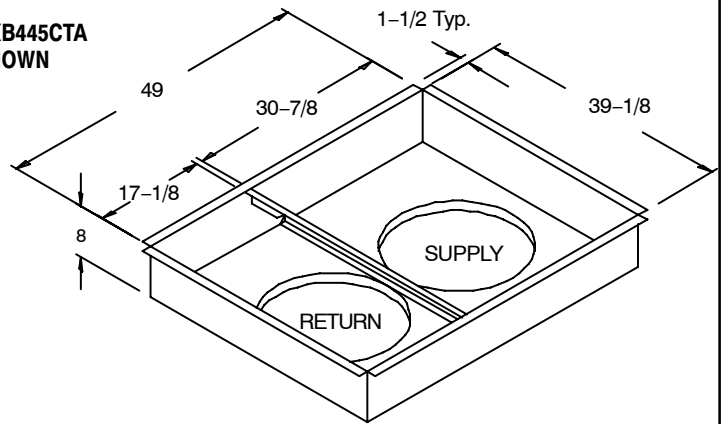

PERFORMANCE DATA ON NEXT PAGE

CONCENTRIC DIFFUSER

Description	Model Number	Used With
Flush Mount	AXB040CFA	AXB445CTA
Flush Mount	AXB045CFA	AXB545CTA
Flush Mount	AXB050CFA	AXB645CTA
Step Down	AXB040CSA	AXB445CTA
Step Down	AXB045CSA	AXB545CTA
Step Down	AXB050CSA	AXB645CTA

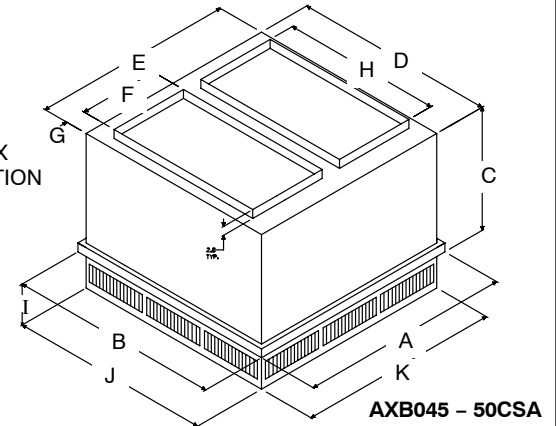
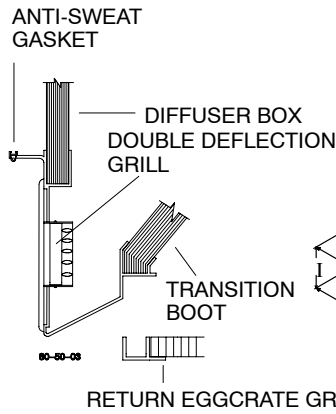
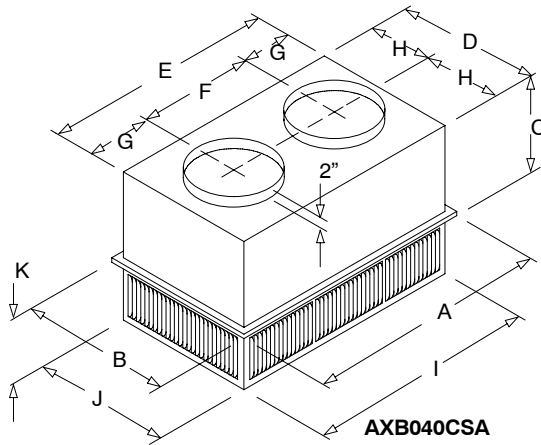

CONCENTRIC DIFFUSER (Step Down)

Model Number	A	B	C	D	E	F	G	H	I	J	K	Duct Size
AXB040CSA	47-5/8	29-3/8	14-3/8	27-1/2	45-1/2	22-1/2	11-1/2	13-3/4	45-1/2	27-1/2	8-1/8	20" RD
AXB045CSA	47-5/8	35-5/8	20-5/8	33-1/2	45-1/2	18	2-1/2	28	9-1/8	33-1/2	45-1/2	18 x 28
AXB050CSA	47-5/8	41-5/8	25-7/8	45-1/2	45-1/2	18	2-1/2	32	9-1/8	39-1/2	45-1/2	18 x 32

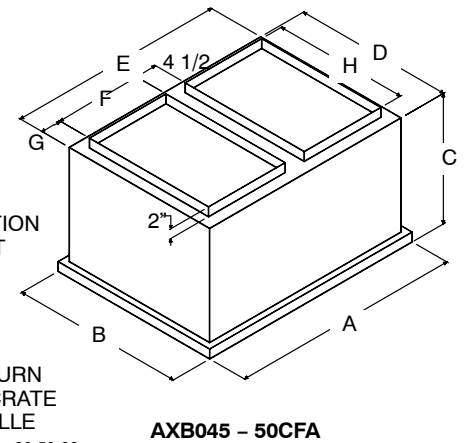
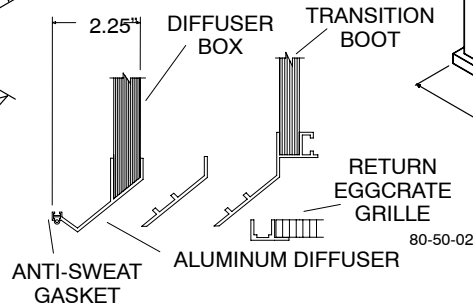
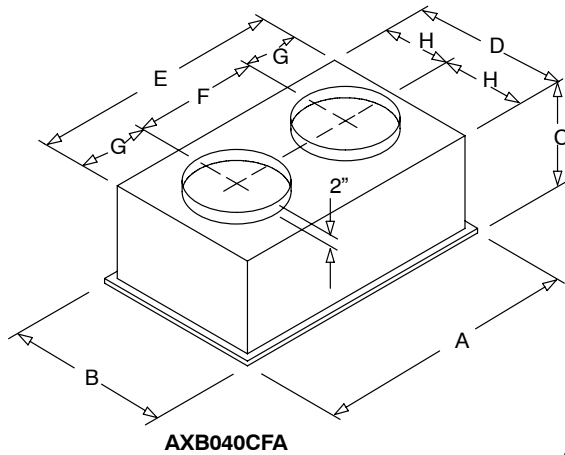

CONCENTRIC DIFFUSER (Flush Mount)

Model Number	A	B	C	D	E	F	G	H	Duct Size
AXB040CFA	47-5/8	29-5/8	16-5/8	27	45	22-1/2	11-1/4	13-1/2	20" RD
AXB045CFA	47-5/8	35-5/8	21-3/4	33	45	18	2-1/4	28	18 x 28
AXB050CFA	47-5/8	41-5/8	29-1/4	39	45	18	2-1/4	32	18 x 32

ACCESSORIES: PGE090 – 150 (CONT.)

CSA SERIES STEP-DOWN PERFORMANCE					
Part No. AXB	CFM	Static Pressure In. WC	Throw Feet	Neck / Jet Velocity FPM	db Sound Levels
040CSA	2600	.17	24-29	669	20
	2800	.20	25-30	720	25
	3000	.25	27-33	772	25
	3200	.31	28-35	823	25
	3400	.37	30-37	874	30
045CSA	3600	.17	25-33	851	30
	3800	.18	27-35	898	30
	4000	.21	29-37	946	30
	4200	.24	32-40	993	30
	4400	.27	34-42	1040	30
050CSA	4400	.29	25-30	733	30
	4600	.31	26-31	767	30
	4800	.32	27-32	800	30
	5000	.34	28-33	833	30
	5200	.36	28-34	867	30
	5400	.39	29-35	900	30

CFA SERIES FLUSH MOUNT PERFORMANCE						
Part No. AXB	CFM	Static Pressure In. WC	Throw Feet	Neck Velocity FPM	Jet Velocity FPM	db Sound Level
040CFA	2600	.17	19-24	663	1294	30
	2800	.20	20-28	714	1393	35
	3000	.25	21-29	765	1492	35
	3200	.31	22-29	816	1592	40
	3400	.37	22-30	867	1692	40
	045CFA	3600	.17	22-29	844	1646
3800		.18	22-30	891	1737	40
4000		.21	24-33	938	1829	40
4200		.24	26-35	985	1920	40
4400		.27	28-37	1032	2011	40
050CFA		4600	.31	25-34	922	1795
	4800	.32	26-35	962	1873	40
	5000	.34	27-36	1002	1951	40
	5200	.36	30-39	1043	2029	45
	5400	.39	32-41	1083	2107	45

CSA/CFA NOTES:

1. All data is based on the Air Diffusion Council guidelines.
2. Throw data is based on Terminal Velocities of 75 FPM using isothermal air.
3. Throw is based on diffuser blades being directed in a straight pattern.
4. Actual sound levels are less than those shown.
5. Minimum height 9' above floor.

7 DAY PROGRAMMABLE COMMERCIAL THERMOSTAT	
Model Number	Used With
1170830	090 - 150
NATURAL TO LP CONVERSION KIT	
Model Number	Used With
AXB345LPA	090 - 150
LOW AMBIENT KIT	
Model Number	Used With
AXB045LAA (-20°)	090 - 150
THRU-THE-BASE POWER KIT	
Model Number	Used With
AXB045PKA	090 - 150

With 1-1/4" Power and 3/4" Gas Connections.

Available thru service parts only.

ACCESSORIES: PGE090 – 150 (CONT.)

POWER EXHAUST

Description	Model Number	Where Used
208/230 Volt	AXB145PEH	090, 102
460 Volt	AXB145PEL	090, 102
575 Volt	AXB145PES	090, 102
208/230 Volt	AXB245PEH	120, 150
460 Volt	AXB245PEL	120, 150
575 Volt	AXB245PES	120, 150

POWER EXHAUST PERFORMANCE DATA

Model	Volt/Phase/ Hertz	Motor			Unit										
		Qty	HP	RPM	Cir. Qty	LRA	FLA	MCA	Fuse Size	@0.0		@0.1	@0.3		
										CFM	RPM	CFM	CFM	RPM	
AXB145PEH	208-230/1/60	1	1/2	1725	1	10.2	4.3	5.4	8	2400	1725	N/A	2100	1725	
AXB145PEL	460/1/60	1	1/2	1625	1	4.1	1.7	2.2	5	2300	1625	N/A	2000	1625	
AXB145PES	575/1/60	1	1/2	1625	1	4.1	1.7	2.2	5	2300	1625	N/A	2000	1625	
AXB245PEH	208-230/1/60	1	3/4	1075	1	24.9	5.0	6.3	10	N/A	N/A	4800	N/A	N/A	
AXB245PEL	460/1/60	1	3/4	1075	1	N/A	2.2	2.8	5	N/A	N/A	4800	N/A	N/A	
AXB245PES	575/1/60	1	3/4	1050	1	N/A	1.5	1.9	4	N/A	N/A	4800	N/A	N/A	

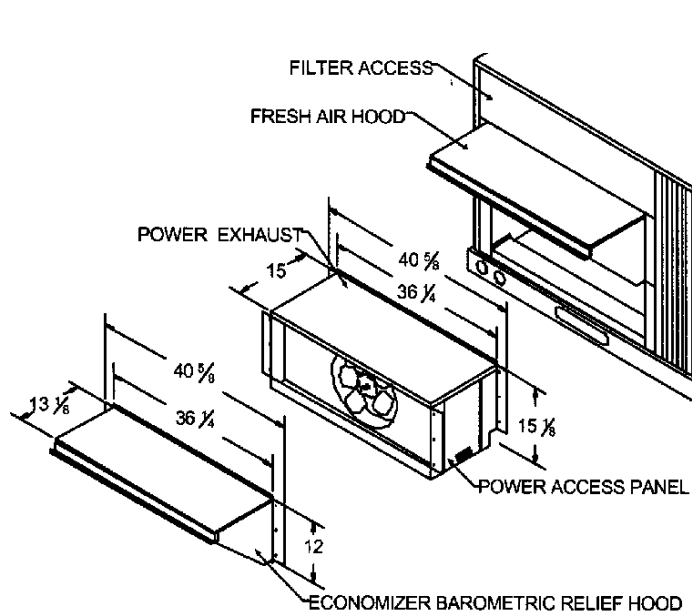

POWER EXHAUST DOWNFLOW, MODEL AXB145***

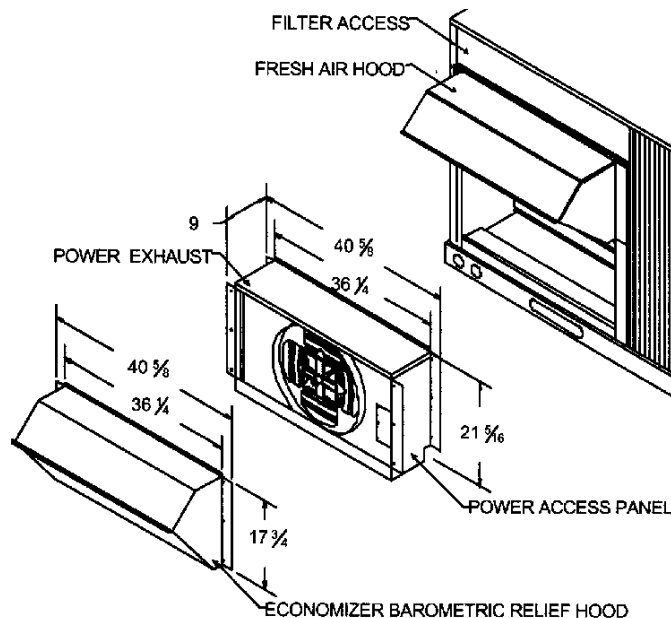

POWER EXHAUST DOWNFLOW, MODEL AXB245***

CONTROLS

OPERATING SEQUENCE

Cooling, Units Without Economizer When thermostat calls for cooling, terminals G and Y1 are energized. The indoor (evaporator) fan contactor (IFC), compressor contactor no. 1 (C1) and outdoor-fan contactor (OFC) are energized, and evaporator-fan motor, compressor no. 1, and both condenser fans start. The condenser-fan motors run continuously while unit is cooling. If the thermostat calls for a second stage of cooling by energizing Y2, compressor contactor no. 2 (C2) is energized and compressor no. 2 starts.

When the thermostat is satisfied, C1 and C2 are deenergized and the compressors and outdoor (condenser) fan motors (OFM) shut off. After a 30-second delay, the indoor (evaporator) fan motor (IFM) shuts off. If the thermostat fan selector switch is in the ON position, the evaporator-fan motor will run continuously.

Heating, Units Without Economizer When the thermostat calls for heating, terminal W1 is energized. In order to prevent thermostat short-cycling, the unit is locked into the Heating mode for at least 1 minute when W1 is energized. The induced-draft motor (IDM) is then energized and the burner ignition sequence begins. The indoor (evaporator) fan motor (IFM) is energized 45 seconds after a flame is ignited. On units equipped for two stages of heat, when additional heat is needed, W2 is energized and the high-fire solenoid on the main gas valve (MGV) is energized. When the thermostat is satisfied and W1 and W2 are deenergized, the IFM stops after a 45-second time-off delay.

APPLICATION DATA

- 1. DUCTWORK** Secure vertical discharge ductwork to roof curb. For horizontal discharge applications, attach ductwork to unit, or field-supplied flanges can be attached to horizontal discharge openings and all ductwork attached to flanges.
- 2. THRU-THE-BOTTOM UTILITY CONNECTIONS** An accessory kit is required for proper installation of thru-the-bottom connections.
- 3. THERMOSTAT** Use of 2-stage cooling thermostat is recommended for all units.
- 4. HEATING-TO-COOLING CHANGEOVER** All units are automatic changeover from heating to cooling when automatic changeover thermostat and subbase are used.
- 5. AIRFLOW** Units are draw-thru on cooling and blow-thru on heating.
- 6. MAXIMUM AIRFLOW** To minimize the possibility of condensate blow-off from evaporator, airflow through units should not exceed 500 cfm/ton.
- 7. MINIMUM AIRFLOW** The minimum airflow for cooling is 300 cfm/ton.
- 8. MINIMUM AMBIENT COOLING OPERATION TEMPERATURE** The cooling temperature for size all units is 25 F.
- 9. MAXIMUM OPERATING OUTDOOR-AIR TEMPERATURE** For cooling, this temperature is 115 F.
- 10. HIGH ALTITUDE** A change to the gas orifice may be required at high altitudes. Refer to Altitude Compensation charts.

11. MINIMUM TEMPERATURE Air entering the heat exchanger in heating must be a minimum of 50 F continuous and 45 F intermittent.

12. INTERNAL UNIT DESIGN Due to the PGS internal unit design (draw-thru over the motor), air path, and specially designed motors, the full horsepower (maximum continuous bhp) listed in the Physical Data table and the notes following each Fan Performance table can be utilized with extreme confidence.

Using PGS motors with the values listed in the Physical and Fan Performance Data tables will not result in nuisance tripping or premature motor failure. The unit warranty will not be affected.

GUIDE SPECIFICATIONS: PGE072-150

CABINET:

The cabinet shall be made of sturdy baked enamel coated galvanized steel. Base rails shall be 16 gauge steel and have fork lift slots and holes provided for lifting shackles. Unit shall be designed with convertible airflow and shipped ready for downflow applications with conversion to horizontal air flow accomplished by relocating two panels.

Return air compartments shall be insulated with not less than 1/2" of water resistant coated glass fiber and not less than 1/2" of aluminum foil faced glass fiber in the furnace/supply compartments.

COOLING SECTION:

Units shall be factory charged and operationally ready. Each refrigeration circuit shall have a compressor, with internal overload protection, high and low pressure switches, filter drier and copper tube/aluminum fin evaporator and condenser coils.

Units shall be capable of cooling operation down to 25°F as shipped from the factory.

COILS:

The evaporator and condenser coils shall be fabricated with aluminum fins mechanically bonded to copper tubing. Both coils shall be pressure tested prior to assembly into the unit and electronically leak tested after assembly onto the unit. The evaporator coil shall be protected from dust and debris on the return air side by factory installed 2" air filters.

CONDENSER FAN:

The unit shall have a single direct drive propeller fan/motor assembly mounted directly to a vertical-discharge grille panel that is easily removable. Motors shall have permanently lubricated sleeve bearings and inherent overload protection.

EVAPORATOR BLOWER:

The units shall have a single belt driven evaporator blower. The motor shall have permanently lubricated ball bearings and internal overload protection. An adjustable motor drive sheave for matching air flow requirements shall be standard.

HEATING SECTION:

The units shall have aluminized steel tubular heat exchangers located on the discharge side of the evaporator blower and equipped with a two-stage gas valve. The units shall have in-shot burners that are ignited by an electronic spark with flame proving feature and protected by both a limit switch and flame roll-out switch.