



PHN5

Product Specifications

15 SEER, 8.0 HSPF, PACKAGE HEAT PUMP, 2 - 5 TONS Single Phase, 208/230 V, 60 Hz.

REFRIGERATION CIRCUIT

- R-410A refrigerant
- Copper tube/aluminum fin condenser and evaporator coils
- Two stage scroll compressors standard on all models with two stages of cooling and heating
- Short-cycling protection for the compressor is built in the defrost control board

EASY TO INSTALL AND SERVICE

- Installs easily on a rooftop or at ground level
- Easy single-panel accessibility for maintenance and installation
- Easily converts to down discharge applications with duct covers provided
- Combination electric heating and cooling

BUILT TO LAST

- Wire Grille
- Heavy-duty pre-painted steel cabinet
- Direct drive high efficiency X-13 blower motor on all models
- Vertical condenser fan discharge
- Rust-proof base with integral sloping drain

LIMITED WARRANTY

- 10-year compressor limited warranty
- 5-year parts limited warranty



This product has been designed and manufactured to meet ENERGY STAR criteria for energy efficiency when matched with appropriate coil components. However, proper refrigerant charge and proper air flow are critical to achieve rated capacity and efficiency. Installation of this product should follow the manufacturer's refrigerant charging and air flow instructions. Failure to confirm proper charge and airflow may reduce energy efficiency and shorten equipment life.



UNIT PERFORMANCE DATA

Model Number	COOLING				Sound Ratings dba †	Unit Dimensions Height x Width x Depth in (mm)	Operating Weight lb / kg
	Nominal Tons	Net Capacity High/Low Stage BTU/h	S.E.E.R*	E.E.R**			
PHN524000K00A	2	22,600 / 17,600	15.0	11.4	75	41 (1042) X 48 (1220) X 31.5 (799)	405 / 184
PHN536000K00A	3	34,600 / 24,400	15.0	12.0	75	45 (1142) X 48 (1220) X 43 (1091)	464 / 211
PHN548000K00A	4	46,000 / 33,400	15.0	11.0	78	47 (1193) X 48 (1220) X 43 (1091)	492 / 223
PHN560000K00A	5	57,000 / 40,500	14.5	11.0	78	51 (1295) X 48 (1220) X 43 (1091)	535 / 243

UNIT PERFORMANCE DATA (Cont)

Model Number	HEATING				
	High Heat Capacity BTU/h @ 47°F (8.3°C) High/Low Stage	High Heat COP @ 47°F (8.3°C) High/Low Stage	Low Heat Capacity BTU/h @ 17°F (-8.3°C) High/Low Stage	Low Heat COP @ 17°F (-8.3°C) High/Low Stage	HSPF*
PHN524000K00A	20,800 / 16,800	3.3 / 3.2	11,600 / 8,400	2.2 / 1.8	8.0
PHN536000K00A	33,600 / 23,000	3.4 / 3.4	17,200 / 11,200	2.4 / 1.7	8.0
PHN548000K00A	45,500 / 32,200	3.3 / 3.5	25,000 / 15,200	2.4 / 1.9	8.0
PHN560000K00A	56,000 / 39,500	3.2 / 3.3	30,800 / 20,400	2.2 / 1.9	8.0

* Rated in accordance with U.S. Government DOE (Department of Energy) test procedures and/or ARI Standards 210/240---94.

** "A" conditions-80°F (26.6°C) indoor db/67°F (19.4°C) indoor wb & 95°F (35°C) outdoor db.

† Tested in accordance with ARI Standard 270---95 (not listed in ARI).

UNIT SPECIFICATIONS

MODEL NUMBER	Electrical Data			Condenser									Sound Ratings (dBA)
				Coil			Fan Motor			Fan			
	208 / 230 Voltage Phase - Hz	HACR Brkr Max Fuse	Minimum Circuit Ampacity	Total Face Area (Sq. Ft.)	Fins Per In. / Rows	Tube Diameter (In.)	HP	Full Load Amps	Locked Rotor Amps	Size Diameter (In.)	RPM (Max.)	CFM (Design)	
PHN524000K00A	1-60	35 amps.	24.1	13.6	21 / 2	3 / 8	1 / 8	0.9	1.6	22	825	2700	75
PHN536000K00A	1-60	40 amps.	27.8	17.5	21 / 2	3 / 8	1 / 8	0.9	1.7	22	825	2800	75
PHN548000K00A	1-60	60 amps.	43.9	19.4	21 / 2	3 / 8	1 / 4	1.5	3.2	22	1100	3300	78
PHN560000K00A	1-60	60 amps.	43.6	23.3	21 / 2	3 / 8	1 / 3	1.9	3.7	22	1110	3300	78

MODEL NUMBER	Evaporator							Scroll Compressor		Factory Refrigerant Charge R-410A (lbs.)
	Coil			Motor		Blower		Rated Load Amps	Locked Rotor Amps	
	Total Face Area (Sq. Ft.)	Fins Per In. / Rows	Tube Diam. (In.)	HP	Full Load Amps	Size	CFM Rated			
PHN524000K00A	3.7	17 / 3	3 / 8	1/2	4.1	10 x 10	800	15.3	52.0	10.3
PHN536000K00A	4.7	17 / 3	3 / 8	3/4	6.0	11 x 10	1200	16.7	82.0	9.7
PHN548000K00A	5.7	17 / 3	3 / 8	1.0	7.6	11 x 10	1600	27.8	96.0	15.5
PHN560000K00A	5.7	17 / 4	3 / 8	1.0	7.6	11 x 10	1850	27.3	118.0	16.0

UNIT PERFORMANCE DATA

Model Number	COOLING				Sound Ratings dba †	Unit Dimensions Height x Width x Depth in (mm)	Operating Weight lb / kg	
	Nominal Tons	Net Capacity High/Low Stage BTU/h		S.E.E.R**				E.E.R**
PHN524000K00A	2	22,600 / 17,600		15.0	11.4	75	41 (1042) X 48 (1220) X 31.5 (799)	405 / 184
PHN536000K00A	3	34,600 / 24,400		15.0	12.0	75	45 (1142) X 48 (1220) X 43 (1091)	464 / 211
PHN548000K00A	4	46,000 / 33,400		15.0	11.0	78	47 (1193) X 48 (1220) X 43 (1091)	492 / 223
PHN560000K00A	5	57,000 / 40,500		14.5	11.0	78	51 (1295) X 48 (1220) X 43 (1091)	535 / 243

Model Number	HEATING					HSPF*			
	High Heat Capacity BTU/h @ 47°F (8.3°C) High/Low Stage		High Heat Cop @ 47°F (8.3°C) High/Low Stage		Low Heat Capacity BTU/h @ 17°F (-8.3°C) High/Low Stage		Low Heat COP @ 17°F (-8.3°C) High/Low Stage		
PHN524000K00A	20,800 / 16,800		3.3 / 3.2		11,600 / 8,400		2.2 / 1.8		8.0
PHN536000K00A	33,600 / 23,000		3.4 / 3.4		17,200 / 11,200		2.4 / 1.7		8.0
PHN548000K00A	45,500 / 32,200		3.3 / 3.5		25,000 / 15,200		2.4 / 1.9		8.0
PHN560000K00A	56,000 / 39,500		3.2 / 3.3		30,800 / 20,400		2.2 / 1.9		8.0

* Rated in accordance with U.S. Government DOE (Department of Energy) test procedures and/or ARI Standards 210/240---94.

** "A" conditions -80°F (26.6°C) indoor db/67°F (19.4°C) indoor wb & 95°F (35°C) outdoor db.

† Tested in accordance with ARI Standard 270---95 (not listed in ARI).

UNIT SIZE	PHN524	PHN536	PHN548	PHN560
HIGH-PRESSURE SWITCH (psig)				
Cutout		670±15		
Reset (Auto)		470±25		
LOSS-OF-CHARGE/LOW-PRESSURE SWITCH (Liquid Line) (psig)				
Cutout		23±5		
Reset (Auto)		55±5		
RETURN-AIR FILTERS* Throwaway in. (mm)	20x24x1 (508x610x25)	24x30x1 (610x762x25)	24x36x1 (610x914x25)	

Dry Coil Air Delivery* - Horizontal Discharge CFM

Unit (Voltage)	Motor Speed	Wire Color	External Static Pressure (IN. W.C.)								
			0.1	0.2	0.3	0.4	0.5	0.6	0.7	0.8	0.9
PHN524 (208/230-1-60)	Low ¹	Blue	659	551	440	335	---	---	---	---	---
	Med-Low	Pink	726	625	537	407	---	---	---	---	---
	Medium ²	Red	907	837	759	679	588	474	343	---	---
	Med-High	Orange	953	870	807	718	652	528	443	---	---
	High	Black	1179	1118	1061	996	942	864	794	718	619
PHN536 (208/230-1-60)	Low ¹	Blue	921	740	448	---	---	---	---	---	---
	Med-Low	Pink	1019	849	603	479	---	---	---	---	---
	Medium ²	Red	1272	1203	1150	1097	1054	996	937	881	841
	Med-High ²	Orange	1321	1258	1212	1168	1114	1075	1009	856	904
	High	Black	1478	1426	1387	1334	1292	1247	1212	1148	1108
PHN548 (208/230-1-60)	Low ¹	Blue	1201	1159	1101	1062	1004	957	897	852	793
	Med-Low	Pink	1419	1364	1318	1258	1214	1160	1118	1053	1009
	Medium ²	Red	1678	1635	1602	1558	1513	1474	1438	1404	1349
	Med-High	Orange	1916	1881	1846	1810	1761	1722	1681	1647	1600
	High	Black	2093	2051	2024	1967	1947	1907	1854	1826	1749
PHN560 (208/230-1-60)	Low ¹	Blue	1320	1256	1211	1142	1096	1028	973	903	835
	Med-Low	Pink	1351	1295	1258	1212	1170	1124	1080	1036	992
	Medium ²	Red	1824	1782	1742	1711	1673	1641	1607	1563	1490
	Med-High	Orange	2001	1958	1923	1883	1831	1776	1705	1624	1538
	High	Black	2292	2238	2158	2049	1935	1840	1732	1635	1513

* Air delivery values are without air filter and are for dry coil (See PHN5 Wet Coil Pressure Drop Table).

¹ Factory-shipped low stage cooling speed

² Factory-shipped high stage cooling speed

NOTE: Deduct field-supplied air filter pressure drop and wet coil pressure drop to obtain external static pressure available for ducting.

ELECTRIC HEATER USAGE CHART

Electric Heater Model Number	Nominal Capacity (kW)	Fuses	Used With Model Sizes			
			24	36	48	60
ELECTRIC HEATERS (208 / 230 — SINGLE PHASE — 60 Hz)						
EHNA05K0N	5.0	0	✓	✓		
EHNA05K4F	5.0	4			✓	✓
EHNA07K4F	7.2	4	✓	✓	✓	✓
EHNA10K4F	10.0	4	✓	✓	✓	✓
EHNA15K6F	15.0	6		✓	✓	✓
EHNA20K6F	20.0	6			✓	✓

ELECTRIC HEATER ELECTRICAL DATA

MODEL SIZE	NOMINAL V-PH-HZ	VOLTAGE RANGE		ELECTRIC HEAT (208V / 230V)		POWER SUPPLY (208V / 230V)	
		MIN	MAX	NOMINAL kW	Full Load Ampacity	Minimum Circuit Ampacity	Maximum Over- Current Protection
24	208 / 230-1-60	187	253	3.8 / 5	18.1 / 20.8	46.8 / 50.1	50 / 60
				5.4 / 7.2	25.9 / 30	56.5 / 61.6	60 / 70
				7.5 / 10	36.1 / 41.7	69.3 / 76.3	70 / 80
36	208 / 230-1-60	187	253	3.8 / 5	18.1 / 20.8	50.4 / 53.8	60 / 60
				5.4 / 7.2	25.9 / 30	60.2 / 65.3	70 / 70
				7.5 / 10	36.1 / 41.7	72.9 / 79.9	80 / 80
				11.3 / 15	54.2 / 62.5	95.5 / 105.9	100 / 110
48	208 / 230-1-60	187	253	3.8 / 5	18.1 / 20.8	66.5 / 69.9	70 / 70
				5.4 / 7.2	25.9 / 30	76.2 / 81.4	80 / 90
				7.5 / 10	36.1 / 41.7	89.0 / 96.0	90 / 100
				11.3 / 15	54.2 / 62.5	111.6 / 122.0	125 / 125
				15 / 20	72.2 / 83.3	134.1 / 148.0	150 / 150
60	208 / 230-1-60	187	253	3.8 / 5	18.1 / 20.8	66.3 / 69.6	70 / 70
				5.4 / 7.2	25.9 / 30	76.0 / 81.1	80 / 90
				7.5 / 10	36.1 / 41.7	88.8 / 95.8	90 / 100
				11.3 / 15	54.2 / 62.5	111.4 / 121.8	125 / 125
				15 / 20	72.2 / 83.3	133.9 / 147.8	150 / 150

PERFORMANCE DATA-STANDARD X-13 INDOOR MOTOR

Cooling Extended Performance Table

PHN524 High Cool

EVAPORATOR AIR		CONDENSER ENTERING AIR TEMPERATURES deg F																	
		75 (23.8°C)			85 (29.4°C)			95 (35°C)			105 (40.5°C)			115 (46.1°C)			125 (51.6°C)		
		CFM	EWB	Total System KW	Capacity MBtuh	Total System KW	Capacity MBtuh	Total System KW	Capacity MBtuh	Total System KW	Capacity MBtuh	Total System KW	Capacity MBtuh	Total System KW	Capacity MBtuh	Total System KW	Capacity MBtuh	Total System KW	
	57	21.77	1.61	20.88	20.88	1.79	19.95	19.95	2.00	18.94	18.94	2.23	17.86	17.86	2.48	16.66	16.66	2.77	
	62	22.40	1.69	21.29	18.21	1.80	20.13	17.70	2.00	18.95	18.95	2.23	17.86	17.86	2.48	16.66	16.66	2.77	
	63	22.85	1.62	21.71	14.70	1.80	20.52	14.21	2.01	19.25	13.70	2.23	17.90	13.16	2.48	16.42	12.58	2.77	
	67	24.66	1.64	23.44	15.24	1.83	22.15	14.75	2.03	20.79	14.24	2.26	19.34	13.70	2.51	17.74	13.12	2.79	
	72	27.16	1.67	25.83	12.28	1.86	24.42	11.80	2.06	22.94	11.29	2.29	21.33	10.76	2.54	19.57	10.18	2.83	
	57	22.76	1.64	21.81	21.81	1.82	20.81	20.81	2.03	19.74	19.74	2.26	18.58	18.58	2.51	17.29	17.29	2.80	
	62	22.97	1.64	21.84	21.76	1.82	20.81	20.81	2.03	19.74	19.74	2.26	18.58	18.58	2.51	17.29	17.29	2.80	
	63	23.39	1.64	22.19	15.71	1.83	20.94	15.21	2.03	19.62	14.69	2.26	18.22	14.14	2.51	16.69	13.54	2.79	
	67	25.22	1.67	23.94	16.32	1.85	22.60	15.82	2.05	21.18	15.30	2.28	19.67	14.74	2.53	18.01	14.14	2.82	
	72	27.77	1.70	26.37	12.96	1.88	24.90	12.48	2.09	23.35	11.95	2.31	21.66	11.41	2.57	20.60	11.05	2.57	

PHN524 Low Cool

EVAPORATOR AIR		CONDENSER ENTERING AIR TEMPERATURES deg F																	
		75 (23.8°C)			85 (29.4°C)			95 (35°C)			105 (40.5°C)			115 (46.1°C)			125 (51.6°C)		
		CFM	EWB	Total System KW	Capacity MBtuh	Total System KW	Capacity MBtuh	Total System KW	Capacity MBtuh	Total System KW	Capacity MBtuh	Total System KW	Capacity MBtuh	Total System KW	Capacity MBtuh	Total System KW	Capacity MBtuh	Total System KW	
	57	16.65	1.05	15.95	15.95	1.20	15.21	15.21	1.37	14.40	14.40	1.57	13.52	13.52	1.80	12.55	12.55	2.07	
	62	17.20	1.06	16.29	14.07	1.21	15.34	13.65	1.37	14.40	14.40	1.57	13.52	13.52	1.80	12.55	12.55	2.07	
	63	17.61	1.06	16.69	11.36	1.21	15.70	10.96	1.38	14.64	10.53	1.57	13.50	10.07	1.80	12.27	9.58	2.06	
	67	19.23	1.08	18.23	11.87	1.22	17.18	11.47	1.39	16.05	11.03	1.58	14.83	10.58	1.81	13.50	10.09	2.07	
	72	21.48	1.09	20.41	9.66	1.24	19.26	9.26	1.41	18.02	8.84	1.60	16.69	8.39	1.83	15.24	7.90	2.09	
	57	17.52	1.08	16.77	16.77	1.23	15.96	15.96	1.39	15.10	15.10	1.59	14.15	14.15	1.82	13.11	13.11	2.09	
	62	17.71	1.08	16.78	16.75	1.23	15.96	15.96	1.39	15.10	15.10	1.59	14.15	14.15	1.82	13.12	13.12	2.09	
	63	18.10	1.08	17.12	12.18	1.23	16.09	11.76	1.39	14.98	11.32	1.59	13.80	10.85	1.81	12.51	10.95	2.08	
	67	19.75	1.09	18.71	12.74	1.24	17.60	12.32	1.41	16.41	11.88	1.60	15.14	11.41	1.83	13.76	10.91	2.09	
	72	22.06	1.11	20.93	10.21	1.26	19.72	9.80	1.43	18.41	9.36	1.62	17.03	8.91	1.85	15.51	8.41	2.11	

PERFORMANCE DATA-STANDARD X-13 INDOOR MOTOR

Heating Extended Performance Table

PHN524 High Heat

INDOOR AIR		OUTDOOR COIL ENTERING AIR TEMPERATURES deg F																					
		-10 (-23.3°C)				0 (-17.7°C)				10 (-12.2°C)				17 (-8.3°C)				20 (-6.6°C)					
		Capacity MBtuh		Total System KW		Capacity MBtuh		Total System KW		Capacity MBtuh		Total System KW		Capacity MBtuh		Total System KW		Capacity MBtuh		Total System KW			
EDB	CFM	Total	Integ	Total	System KW	Total	Integ	Total	System KW	Total	Integ	Total	System KW	Total	Integ	Total	System KW	Total	Integ	Total	System KW		
60	700	4.21	3.88	1.12	6.40	5.89	1.21	9.38	8.61	1.32	11.90	10.85	1.42	14.22	12.90	1.45	17.90	16.45	1.75	20.75	19.00	2.00	23.25
	800	4.24	3.90	1.11	6.47	5.95	1.20	9.46	8.69	1.31	11.94	10.89	1.43	14.27	12.94	1.44	17.94	16.48	1.76	20.76	19.01	2.01	23.26
70	700	3.97	3.65	1.25	6.12	5.63	1.35	9.01	8.27	1.46	11.51	10.49	1.55	12.36	11.21	1.49	16.86	15.55	1.75	19.75	18.10	1.90	21.90
	800	4.02	3.70	1.24	6.20	5.71	1.34	9.12	8.37	1.45	11.60	10.58	1.55	12.46	11.30	1.66	16.91	15.60	1.76	20.00	18.30	1.90	22.00
80	700	3.77	3.47	1.38	5.83	5.36	1.49	8.62	7.91	1.61	11.03	10.06	1.70	11.85	10.75	1.75	16.70	15.35	1.70	19.70	18.05	1.90	21.70
	800	3.82	3.51	1.38	5.91	5.43	1.48	8.74	8.02	1.59	11.17	10.19	1.69	12.00	10.88	1.72	16.80	15.40	1.70	20.00	18.30	1.90	22.00

PHN524 High Heat Cont.

INDOOR AIR		OUTDOOR COIL ENTERING AIR TEMPERATURES deg F																					
		30 (-1.1°C)				40 (4.4°C)				47 (8.3°C)				50 (10°C)				60 (15.5°C)					
		Capacity MBtuh		Total System KW		Capacity MBtuh		Total System KW		Capacity MBtuh		Total System KW		Capacity MBtuh		Total System KW		Capacity MBtuh		Total System KW			
EDB	CFM	Total	Integ	Total	System KW	Total	Integ	Total	System KW	Total	Integ	Total	System KW	Total	Integ	Total	System KW	Total	Integ	Total	System KW		
60	700	16.65	14.60	1.58	19.30	19.30	1.69	21.15	21.15	1.75	22.00	22.00	1.78	25.14	25.14	1.92	28.22	28.22	2.00	30.00	30.00	2.10	33.10
	800	16.84	14.76	1.53	19.36	19.36	1.61	21.27	21.27	1.66	22.16	22.16	1.70	25.40	25.40	1.82	28.50	28.50	2.00	30.00	30.00	2.10	33.10
70	700	16.03	14.05	1.62	18.69	18.69	1.86	20.68	20.68	1.95	21.51	21.51	1.98	24.54	24.54	2.11	27.41	27.41	2.20	29.20	29.20	2.30	32.00
	800	16.25	14.24	1.68	18.95	18.95	1.79	20.80	20.80	1.85	21.65	21.65	1.87	24.82	24.82	2.00	27.65	27.65	2.20	29.20	29.20	2.30	32.00
80	700	14.91	13.06	1.89	17.97	17.97	2.03	20.04	20.04	2.14	20.96	20.96	2.20	23.91	23.91	2.32	26.83	26.83	2.40	27.40	27.40	2.50	30.00
	800	15.10	13.23	1.84	18.27	18.27	1.96	20.30	20.30	2.05	21.13	21.13	2.08	24.20	24.20	2.21	27.07	27.07	2.40	27.40	27.40	2.50	30.00

LEGEND

Cap.— Heating Capacity (1000 Btuh) (Includes Indoor-Fan Motor Heat)

db — Dry Bulb

kw — Total Power Input (Includes Compressor Motor Power Input Outdoor-Fan Motor Input, and Indoor-Fan Motor Input)

rh — Relative Humidity

NOTES:

Integrated capacity is maximum (instantaneous) capacity less the effect of frost on the outdoor coil and the heat required to defrost it.

PERFORMANCE DATA-STANDARD X-13 INDOOR MOTOR

Heating Extended Performance Table

PHN524 Low Heat

INDOOR AIR		OUTDOOR COIL ENTERING AIR TEMPERATURES deg F																				
		-10 (-23.3°C)				0 (-17.7°C)				10 (-12.2°C)				17 (-8.3°C)				20 (-6.6°C)				
		Capacity MBtuh		Total System KW		Capacity MBtuh		Total System KW		Capacity MBtuh		Total System KW		Capacity MBtuh		Total System KW		Capacity MBtuh		Total System KW		
EDB	CFM	Total	Integ	Total	System KW	Total	Integ	Total	System KW	Total	Integ	Total	System KW	Total	Integ	Total	System KW	Total	Integ	Total	System KW	
60	525	2.95	2.72	1.05	4.89	4.50	1.11	7.22	6.63	1.18	8.74	7.97	1.22	9.48	8.60	1.24						
	600	2.99	2.75	1.04	4.97	4.58	1.09	7.31	6.71	1.17	8.89	8.11	1.20	9.64	8.74	1.22						
70	525	2.81	2.59	1.22	4.72	4.34	1.29	6.73	6.18	1.35	8.26	7.53	1.38	8.97	8.14	1.40						
	600	2.87	2.64	1.21	4.80	4.41	1.28	6.87	6.30	1.34	8.40	7.66	1.37	9.13	8.28	1.38						
80	525	2.61	2.41	1.37	4.45	4.09	1.46	6.26	5.75	1.52	7.78	7.10	1.56	8.46	7.68	1.57						
	600	2.66	2.46	1.36	4.53	4.16	1.44	6.38	5.86	1.51	7.92	7.22	1.54	8.60	7.80	1.56						

PHN524 Low Heat (Cont.)

INDOOR AIR		OUTDOOR COIL ENTERING AIR TEMPERATURES deg F																				
		30 (-1.1°C)				40 (4.4°C)				47 (8.3°C)				50 (10°C)				60 (15.5°C)				
		Capacity MBtuh		Total System KW		Capacity MBtuh		Total System KW		Capacity MBtuh		Total System KW		Capacity MBtuh		Total System KW		Capacity MBtuh		Total System KW		
EDB	CFM	Total	Integ	Total	System KW	Total	Integ	Total	System KW	Total	Integ	Total	System KW	Total	Integ	Total	System KW	Total	Integ	Total	System KW	
60	525	12.17	10.66	1.30	15.20	15.20	1.37	17.28	17.28	1.41	18.16	18.16	1.44	19.43	19.43	1.44						
	600	12.37	10.84	1.27	15.22	15.22	1.33	16.79	16.79	1.37	16.85	16.85	1.36	16.78	16.78	1.29						
70	525	11.60	10.17	1.46	14.55	14.55	1.54	16.84	16.84	1.61	17.86	17.86	1.64	20.96	20.96	1.71						
	600	11.80	10.34	1.43	14.80	14.80	1.50	16.80	16.80	1.54	17.64	17.64	1.57	18.39	18.39	1.53						
80	525	11.00	9.64	1.64	13.91	13.91	1.72	16.15	16.15	1.79	17.17	17.17	1.83	20.53	20.53	1.91						
	600	11.21	9.83	1.61	14.16	14.16	1.68	16.40	16.40	1.74	17.36	17.36	1.77	20.33	20.33	1.85						

LEGEND

Cap.— Heating Capacity (1000 Btuh) (Includes Indoor-Fan Motor Heat)

db — Dry Bulb

kW — Total Power Input (Includes Compressor Motor Power Input Outdoor-Fan Motor Input, and Indoor-Fan Motor Input)

rh — Relative Humidity

NOTES:

Integrated capacity is maximum (instantaneous) capacity less the effect of frost on the outdoor coil and the heat required to defrost it.

PERFORMANCE DATA-STANDARD X-13 INDOOR MOTOR

Cooling Extended Performance Table

PHN536 High Cool

EVAPORATOR AIR		CONDENSER ENTERING AIR TEMPERATURES deg F																	
		75 (23.8°C)			85 (29.4°C)			95 (35°C)			105 (40.5°C)			115 (46.1°C)			125 (51.6°C)		
		Capacity MBtuh	Total System KW	EWB	Capacity MBtuh	Total System KW	EWB	Capacity MBtuh	Total System KW	EWB	Capacity MBtuh	Total System KW	EWB	Capacity MBtuh	Total System KW	EWB	Capacity MBtuh	Total System KW	EWB
1050	57	33.64	2.28	32.32	2.53	30.90	2.81	29.36	3.11	27.65	3.46	25.71	3.84	25.71	3.84	25.71	3.84	25.71	3.84
	62	34.47	2.29	32.83	2.54	31.11	2.81	29.36	3.11	27.65	3.46	25.71	3.84	25.71	3.84	25.71	3.84	25.71	3.84
	63	35.12	2.29	33.44	2.56	31.65	2.81	29.73	3.12	27.64	3.45	25.33	3.83	25.33	3.83	25.33	3.83	25.33	3.83
	67	37.76	2.32	35.94	2.57	34.00	2.84	31.91	3.15	29.65	3.49	27.14	3.87	27.14	3.87	27.14	3.87	27.14	3.87
	73	42.16	2.37	40.12	2.62	37.93	2.90	35.58	3.20	33.02	3.54	30.21	3.92	30.21	3.92	30.21	3.92	30.21	3.92
1200	57	35.06	2.32	33.64	2.58	32.12	2.85	30.46	3.16	28.63	3.50	26.56	3.89	26.56	3.89	26.56	3.89	26.56	3.89
	62	35.29	2.33	33.64	2.58	32.12	2.85	30.46	3.16	28.63	3.50	26.56	3.89	26.56	3.89	26.56	3.89	26.56	3.89
	63	35.86	2.33	34.09	2.58	32.22	2.85	30.23	3.15	28.05	3.49	25.66	3.87	25.66	3.87	25.66	3.87	25.66	3.87
	67	38.52	2.36	36.62	2.61	34.60	2.88	32.43	3.19	30.06	3.53	27.47	3.90	27.47	3.90	27.47	3.90	27.47	3.90
	73	42.99	2.41	40.85	2.66	38.57	2.93	36.13	3.24	33.48	3.58	30.56	3.96	30.56	3.96	30.56	3.96	30.56	3.96

PHN536 Low Cool

EVAPORATOR AIR		CONDENSER ENTERING AIR TEMPERATURES deg F																	
		75 (23.8°C)			85 (29.4°C)			95 (35°C)			105 (40.5°C)			115 (46.1°C)			125 (51.6°C)		
		Capacity MBtuh	Total System KW	EWB	Capacity MBtuh	Total System KW	EWB	Capacity MBtuh	Total System KW	EWB	Capacity MBtuh	Total System KW	EWB	Capacity MBtuh	Total System KW	EWB	Capacity MBtuh	Total System KW	EWB
745	57	23.27	1.46	22.34	1.65	21.31	1.87	20.19	2.12	18.95	2.41	17.58	2.76	17.58	2.76	17.58	2.76	17.58	2.76
	62	23.91	1.46	22.70	1.66	21.41	1.87	20.19	2.12	18.95	2.41	17.58	2.76	17.58	2.76	17.58	2.76	17.58	2.76
	63	24.46	1.47	23.21	1.66	21.87	1.87	20.42	2.12	18.85	2.41	17.14	2.75	17.14	2.75	17.14	2.75	17.14	2.75
	67	26.63	1.48	25.29	1.67	23.85	1.89	22.28	2.14	20.58	2.43	18.72	2.77	18.72	2.77	18.72	2.77	18.72	2.77
	72	29.67	1.51	28.20	1.70	26.61	1.91	24.89	2.16	23.01	2.45	20.96	2.79	20.96	2.79	20.96	2.79	20.96	2.79
850	57	24.45	1.48	23.43	1.67	22.33	1.89	21.11	2.14	19.80	2.44	18.32	2.78	18.32	2.78	18.32	2.78	18.32	2.78
	62	24.61	1.48	23.43	1.67	22.33	1.89	21.12	2.14	19.80	2.44	18.32	2.78	18.32	2.78	18.32	2.78	18.32	2.78
	63	25.11	1.49	23.80	1.68	22.39	1.89	20.88	2.14	19.24	2.43	17.46	2.77	17.46	2.77	17.46	2.77	17.46	2.77
	67	27.33	1.50	25.92	1.69	24.40	1.91	22.76	2.15	20.99	2.44	19.06	2.78	19.06	2.78	19.06	2.78	19.06	2.78
	72	30.44	1.53	28.89	1.71	27.21	1.93	25.40	2.17	23.45	2.46	21.30	2.80	21.30	2.80	21.30	2.80	21.30	2.80

PERFORMANCE DATA-STANDARD X-13 INDOOR MOTOR

Heating Extended Performance Table

PHN536 High Heat

INDOOR AIR		OUTDOOR COIL ENTERING AIR TEMPERATURES deg F																				
		-10 (-23.3°C)				0 (-17.7°C)				10 (-12.2°C)				17 (-8.3°C)				20 (-6.6°C)				
		Capacity MBtuh		Total System KW		Capacity MBtuh		Total System KW		Capacity MBtuh		Total System KW		Capacity MBtuh		Total System KW		Capacity MBtuh		Total System KW		
EDB	CFM	Total	Integ	Total	Integ	Total	Integ	Total	Integ	Total	Integ	Total	Integ	Total	Integ	Total	Integ	Total	Integ	Total	Integ	
60	1050	8.62	7.93	1.43	10.43	1.60	14.73	13.52	1.78	17.57	16.02	1.92	18.91	17.15	1.99							
	1200	8.70	8.01	1.43	11.45	1.59	14.88	13.66	1.77	17.76	16.19	1.90	19.11	17.33	1.97							
70	1050	8.34	7.68	1.59	10.14	1.77	14.26	13.09	1.97	16.99	15.49	2.12	18.32	16.61	2.19							
	1200	8.44	7.77	1.59	11.14	1.77	14.42	13.24	1.96	17.20	15.68	2.10	18.53	16.81	2.17							
80	1050	7.96	7.32	1.74	10.60	1.95	13.78	12.65	2.17	16.38	14.93	2.33	17.63	15.99	2.40							
	1200	8.07	7.43	1.74	10.74	1.94	13.93	12.79	2.15	16.59	15.12	2.31	17.86	16.19	2.38							

PHN536 High Heat (Cont.)

INDOOR AIR		OUTDOOR COIL ENTERING AIR TEMPERATURES deg F																				
		30 (-1.1°C)				40 (4.4°C)				47 (8.3°C)				50 (10°C)				60 (15.5°C)				
		Capacity MBtuh		Total System KW		Capacity MBtuh		Total System KW		Capacity MBtuh		Total System KW		Capacity MBtuh		Total System KW		Capacity MBtuh		Total System KW		
EDB	CFM	Total	Integ	Total	Integ	Total	Integ	Total	Integ	Total	Integ	Total	Integ	Total	Integ	Total	Integ	Total	Integ	Total	Integ	
60	1050	23.95	20.99	2.22	29.99	2.51	34.51	34.51	2.69	36.57	36.57	2.79	43.09	43.09	3.12							
	1200	24.20	21.21	2.20	30.20	2.45	34.82	34.82	2.67	36.95	36.95	2.74	43.39	43.39	2.88							
70	1050	23.16	20.29	2.44	28.99	2.73	33.82	33.82	2.98	35.98	35.98	3.08	42.90	42.90	3.44							
	1200	23.44	20.54	2.41	29.28	2.71	33.60	33.60	2.90	35.59	35.59	3.00	43.10	43.10	3.30							
80	1050	22.38	19.61	2.67	28.03	2.99	32.65	32.65	3.24	34.87	34.87	3.37	42.66	42.66	3.75							
	1200	22.66	19.86	2.64	28.36	2.94	33.00	33.00	3.21	34.97	34.97	3.29	42.80	42.80	3.69							

PERFORMANCE DATA-STANDARD X-13 INDOOR MOTOR

Heating Extended Performance Table

PHN536 Low Heat

INDOOR AIR		OUTDOOR COIL ENTERING AIR TEMPERATURES deg F																				
		-10 (-23.3°C)				0 (-17.7°C)				10 (-12.2°C)				17 (-8.3°C)				20 (-6.6°C)				
		Capacity MBtuh		Total System KW		Capacity MBtuh		Total System KW		Capacity MBtuh		Total System KW		Capacity MBtuh		Total System KW		Capacity MBtuh		Total System KW		
EDB	CFM	Total	Integ	Total	Integ	Total	Integ	Total	Integ	Total	Integ	Total	Integ	Total	Integ	Total	Integ	Total	Integ	Total	Integ	
60	745	3.84	3.53	1.62	6.63	6.10	1.68	9.48	8.70	1.72	11.69	10.66	1.74	12.69	11.51	1.75						
	850	3.91	3.60	1.62	6.71	6.17	1.67	9.61	8.82	1.70	11.84	10.80	1.71	12.85	11.66	1.72						
70	745	3.10	2.86	1.82	5.88	5.41	1.89	8.83	8.10	1.93	11.03	10.06	1.95	12.02	10.90	1.96						
	850	3.23	2.98	1.82	6.01	5.53	1.89	8.98	8.24	1.92	11.20	10.21	1.93	12.20	11.07	1.94						
80	745	2.22	2.05	2.03	5.00	4.60	2.10	8.01	7.35	2.15	10.24	9.33	2.18	11.23	10.18	2.19						
	850	2.34	2.16	2.04	5.12	4.71	2.11	8.17	7.49	2.14	10.42	9.50	2.16	11.42	10.36	2.16						

PHN536 Low Heat(Cont.)

INDOOR AIR		OUTDOOR COIL ENTERING AIR TEMPERATURES deg F																				
		30 (-1.1°C)				40 (4.4°C)				47 (8.3°C)				50 (10°C)				60 (15.5°C)				
		Capacity MBtuh		Total System KW		Capacity MBtuh		Total System KW		Capacity MBtuh		Total System KW		Capacity MBtuh		Total System KW		Capacity MBtuh		Total System KW		
EDB	CFM	Total	Integ	Total	Integ	Total	Integ	Total	Integ	Total	Integ	Total	Integ	Total	Integ	Total	Integ	Total	Integ	Total	Integ	
60	745	16.25	14.24	1.78	20.33	20.33	1.81	23.56	23.56	1.84	25.01	25.01	1.85	30.27	30.27	1.90						
	850	16.46	14.42	1.74	20.70	20.70	1.76	23.96	23.96	1.78	25.46	25.46	1.78	30.88	30.88	1.82						
70	745	15.55	13.62	1.99	19.45	19.45	2.02	22.61	22.61	2.05	24.02	24.02	2.06	29.09	29.09	2.11						
	850	15.78	13.82	1.95	19.78	19.78	1.97	23.00	23.00	1.98	24.44	24.44	1.99	29.68	29.68	2.02						
80	745	14.74	12.91	2.22	18.60	18.60	2.26	21.56	21.56	2.28	22.94	22.94	2.29	27.95	27.95	2.35						
	850	14.98	13.13	2.18	18.90	18.90	2.20	21.95	21.95	2.21	23.44	23.44	2.22	28.50	28.50	2.25						

LEGEND

Cap.— Heating Capacity (1000 Btuh) (Includes Indoor-Fan Motor Heat)

db — Dry Bulb

kW — Total Power Input (Includes Compressor Motor Power Input Outdoor-Fan Motor Input, and Indoor-Fan Motor Input)

rh — Relative Humidity

NOTES:

Integrated capacity is maximum (instantaneous) capacity less the effect of frost on the outdoor coil and the heat required to defrost it.

PERFORMANCE DATA-STANDARD X-13 INDOOR MOTOR

Cooling Extended Performance Table

PHN548 High Cool

EVAPORATOR AIR		CONDENSER ENTERING AIR TEMPERATURES deg F																	
CFM	EWB	75 (23.8°C)			85 (29.4°C)			95 (35°C)			105 (40.5°C)			115 (46.1°C)			125 (51.6°C)		
		Capacity MBtuh	Total System KW		Capacity MBtuh	Total System KW		Capacity MBtuh	Total System KW		Capacity MBtuh	Total System KW		Capacity MBtuh	Total System KW		Capacity MBtuh	Total System KW	
		Total	Sens		Total	Sens		Total	Sens		Total	Sens	Total	Sens		Total	Sens	Total	Sens
	57	44.39	44.39	3.40	42.70	42.70	3.71	40.87	40.87	4.05	38.88	38.88	4.43	36.67	36.67	4.84	34.16	34.16	5.30
	62	45.43	38.20	3.41	43.33	37.29	3.72	41.11	36.31	4.05	38.87	38.87	4.43	36.67	36.67	4.84	35.30	35.30	4.84
1400	63	46.29	30.85	3.42	44.11	29.95	3.73	41.79	29.00	4.06	39.28	28.00	4.43	36.54	26.91	4.84	33.51	25.73	5.29
	67	50.04	32.01	3.46	47.71	31.11	3.77	45.21	30.16	4.11	42.50	29.14	4.48	41.00	28.60	4.43	36.24	26.85	5.34
	72	55.24	25.88	3.53	52.68	24.98	3.84	49.93	24.04	4.18	46.96	23.04	4.55	45.43	22.53	4.52	40.04	20.75	5.41
	57	46.32	46.32	3.48	44.10	44.10	3.79	42.54	42.54	4.13	40.41	40.41	4.51	38.04	38.04	4.92	36.62	36.62	4.93
	62	46.57	41.09	3.48	44.43	44.43	3.79	42.54	42.54	4.13	41.40	41.40	4.51	38.04	38.04	4.92	36.61	36.61	4.93
1600	63	47.25	32.81	3.49	44.97	31.89	3.80	42.55	30.92	4.13	39.95	29.90	4.50	37.11	28.80	4.91	33.97	27.59	5.36
	67	51.07	34.10	3.53	48.62	33.18	3.84	46.00	32.20	4.18	43.19	31.17	4.55	40.12	30.06	4.96	38.36	29.43	4.97
	72	56.36	27.17	3.60	53.67	26.25	3.91	50.80	25.29	4.25	47.69	24.26	4.62	44.30	23.15	5.03	42.55	22.59	5.06

PHN548 Low Cool

EVAPORATOR AIR		CONDENSER ENTERING AIR TEMPERATURES deg F																	
CFM	EWB	75 (23.8°C)			85 (29.4°C)			95 (35°C)			105 (40.5°C)			115 (46.1°C)			125 (51.6°C)		
		Capacity MBtuh	Total System KW		Capacity MBtuh	Total System KW		Capacity MBtuh	Total System KW		Capacity MBtuh	Total System KW		Capacity MBtuh	Total System KW		Capacity MBtuh	Total System KW	
		Total	Sens		Total	Sens		Total	Sens		Total	Sens	Total	Sens		Total	Sens	Total	Sens
	57	31.49	31.49	2.22	30.30	30.30	2.49	29.02	29.02	2.78	27.63	27.63	3.12	26.10	26.10	3.51	24.40	24.40	3.96
	62	32.49	27.41	2.21	30.96	26.74	2.48	29.34	26.03	2.78	27.64	27.57	3.12	26.10	26.10	3.51	24.40	24.40	3.97
965	63	33.19	22.28	2.21	31.62	21.62	2.48	29.95	20.92	2.78	28.14	20.18	3.12	26.19	19.39	3.52	24.04	18.53	3.97
	67	36.14	23.21	2.21	34.45	22.54	2.47	32.65	21.84	2.77	30.72	21.10	3.10	28.62	20.30	3.49	26.31	19.44	3.94
	72	40.19	19.02	2.21	38.34	18.36	2.46	36.37	17.67	2.75	34.25	16.93	3.08	31.95	16.14	3.46	29.40	15.29	3.90
	57	33.04	33.04	2.24	31.76	31.76	2.50	30.39	30.39	2.80	28.90	28.90	3.13	27.27	27.27	3.52	25.45	25.45	3.97
	62	33.42	29.57	2.23	31.85	28.86	2.50	30.39	30.39	2.80	28.90	28.90	3.13	27.27	27.27	3.52	25.45	25.45	3.97
1100	63	34.05	23.76	2.23	32.40	23.08	2.50	30.64	22.37	2.80	28.77	21.61	3.14	26.73	20.81	3.53	24.50	19.92	3.99
	67	37.06	24.78	2.23	35.29	24.10	2.49	33.40	23.38	2.78	31.39	22.62	3.12	29.20	21.81	3.51	26.79	20.93	3.95
	72	41.21	20.03	2.23	39.26	19.35	2.48	37.19	18.64	2.77	34.96	17.88	3.10	32.54	17.07	3.48	29.89	16.19	3.92

PERFORMANCE DATA-STANDARD X-13 INDOOR MOTOR

Heating Extended Performance Table

PHN548 High Heat

INDOOR AIR		OUTDOOR COIL ENTERING AIR TEMPERATURES deg F																				
		-10 (-23.3°C)				0 (-17.7°C)				10 (-12.2°C)				17 (-8.3°C)				20 (-6.6°C)				
		Capacity MBtuh		Total System KW		Capacity MBtuh		Total System KW		Capacity MBtuh		Total System KW		Capacity MBtuh		Total System KW		Capacity MBtuh		Total System KW		
EDB	CFM	Total	Integ	Total	Integ	Total	Integ	Total	Integ	Total	Integ	Total	Integ	Total	Integ	Total	Integ	Total	Integ	Total	Integ	
60	1400	13.33	12.27	2.19	17.37	15.98	20.10	2.63	21.89	20.10	2.80	25.47	23.23	27.14	24.61	2.88	27.47	24.92	2.88	27.47	24.92	2.88
	1600	13.53	12.45	2.21	17.59	16.18	22.14	2.64	22.14	20.32	2.80	25.78	23.51	27.47	24.92	2.88	27.47	24.92	2.88	27.47	24.92	2.88
70	1400	12.72	11.71	2.39	16.74	15.40	19.50	2.87	21.24	19.50	2.87	24.70	22.52	26.27	23.83	3.13	26.27	23.83	3.13	26.27	23.83	3.13
	1600	12.94	11.91	2.41	16.98	15.62	21.52	2.88	21.52	19.75	2.88	25.00	22.79	26.61	24.14	3.13	26.61	24.14	3.13	26.61	24.14	3.13
80	1400	11.86	10.91	2.58	15.90	14.63	20.40	2.84	20.40	18.73	3.11	23.85	21.74	25.40	23.04	3.40	25.40	23.04	3.40	25.40	23.04	3.40
	1600	12.09	11.12	2.61	16.17	14.88	20.70	2.86	20.70	19.00	3.12	24.18	22.05	25.75	23.36	3.40	25.75	23.36	3.40	25.75	23.36	3.40

PHN548 High Heat (Cont.)

INDOOR AIR		OUTDOOR COIL ENTERING AIR TEMPERATURES deg F																				
		30 (-1.1°C)				40 (4.4°C)				47 (8.3°C)				50 (10°C)				60 (15.5°C)				
		Capacity MBtuh		Total System KW		Capacity MBtuh		Total System KW		Capacity MBtuh		Total System KW		Capacity MBtuh		Total System KW		Capacity MBtuh		Total System KW		
EDB	CFM	Total	Integ	Total	Integ	Total	Integ	Total	Integ	Total	Integ	Total	Integ	Total	Integ	Total	Integ	Total	Integ	Total	Integ	
60	1400	33.39	29.26	3.16	40.69	40.69	3.49	46.59	46.59	3.77	49.36	49.36	3.91	58.12	58.12	4.29	58.12	58.12	4.29	58.12	58.12	4.29
	1600	33.83	29.64	3.15	41.16	41.16	3.48	46.62	46.62	3.72	49.42	49.42	3.83	58.16	58.16	4.22	58.16	58.16	4.22	58.16	58.16	4.22
70	1400	32.29	28.29	3.43	39.25	39.25	3.77	44.95	44.95	4.05	47.65	47.65	4.19	57.17	57.17	4.65	57.17	57.17	4.65	57.17	57.17	4.65
	1600	32.73	28.68	3.41	39.82	39.82	3.74	45.50	45.50	4.04	48.12	48.12	4.17	57.23	57.23	4.57	57.23	57.23	4.57	57.23	57.23	4.57
80	1400	31.08	27.23	3.71	37.81	37.81	4.07	43.28	43.28	4.37	45.87	45.87	4.51	55.65	55.65	5.07	55.65	55.65	5.07	55.65	55.65	5.07
	1600	31.53	27.62	3.69	38.39	38.39	4.04	43.94	43.94	4.33	46.54	46.54	4.48	55.70	55.70	4.92	55.70	55.70	4.92	55.70	55.70	4.92

LEGEND

Cap.— Heating Capacity (1000 Btuh) (Includes Indoor-Fan Motor Heat)

db — Dry Bulb

kW — Total Power Input (Includes Compressor Motor Power Input Outdoor-Fan Motor Input, and Indoor-Fan Motor Input)

rh — Relative Humidity

NOTES:

Integrated capacity is maximum (instantaneous) capacity less the effect of frost on the outdoor coil and the heat required to defrost it.

PERFORMANCE DATA-STANDARD X-13 INDOOR MOTOR

Heating Extended Performance Table

PHN548 Low Heat

INDOOR AIR		OUTDOOR COIL ENTERING AIR TEMPERATURES deg F																				
		-10 (-23.3°C)				0 (-17.7°C)				10 (-12.2°C)				17 (-8.3°C)				20 (-6.6°C)				
		Capacity MBtuh		Total System KW		Capacity MBtuh		Total System KW		Capacity MBtuh		Total System KW		Capacity MBtuh		Total System KW		Capacity MBtuh		Total System KW		
EDB	CFM	Total	Integ	Total	Integ	Total	Integ	Total	Integ	Total	Integ	Total	Integ	Total	Integ	Total	Integ	Total	Integ	Total	Integ	
60	965	5.86	5.39	1.86	9.04	8.32	1.96	12.71	11.67	2.05	15.64	14.26	2.12	17.00	15.42	2.15						
	1100	5.95	5.47	1.86	9.16	8.42	1.95	12.85	11.79	2.03	15.80	14.41	2.09	17.18	15.58	2.12						
70	965	5.21	4.80	2.08	8.43	7.76	2.19	12.11	11.12	2.30	15.01	13.69	2.37	16.35	14.83	2.41						
	1100	5.32	4.89	2.08	8.56	7.88	2.18	12.27	11.27	2.28	15.20	13.86	2.34	16.55	15.01	2.37						
80	965	4.44	4.09	2.32	7.66	7.05	2.43	11.36	10.42	2.55	14.25	12.99	2.64	15.58	14.13	2.68						
	1100	4.55	4.18	2.33	7.79	7.17	2.43	11.53	10.58	2.54	14.45	13.17	2.61	15.80	14.33	2.64						

PHN548 Low Heat (Cont.)

INDOOR AIR		OUTDOOR COIL ENTERING AIR TEMPERATURES deg F																				
		30 (-1.1°C)				40 (4.4°C)				47 (8.3°C)				50 (10°C)				60 (15.5°C)				
		Capacity MBtuh		Total System KW		Capacity MBtuh		Total System KW		Capacity MBtuh		Total System KW		Capacity MBtuh		Total System KW		Capacity MBtuh		Total System KW		
EDB	CFM	Total	Integ	Total	Integ	Total	Integ	Total	Integ	Total	Integ	Total	Integ	Total	Integ	Total	Integ	Total	Integ	Total	Integ	
60	965	21.99	19.27	2.26	27.98	27.98	2.40	32.83	32.83	2.51	35.07	35.07	2.56	43.68	43.68	2.76						
	1100	22.24	19.48	2.22	28.40	28.40	2.33	33.33	33.33	2.43	35.65	35.65	2.47	44.63	44.63	2.66						
70	965	21.27	18.64	2.53	26.97	26.97	2.66	31.72	31.72	2.78	33.87	33.87	2.84	41.97	41.97	3.05						
	1100	21.53	18.87	2.48	27.36	27.36	2.59	32.20	32.20	2.70	34.41	34.41	2.74	42.84	42.84	2.93						
80	965	20.45	17.92	2.81	26.04	26.04	2.96	30.48	30.48	3.08	32.72	32.72	3.15	40.41	40.41	3.37						
	1100	20.73	18.16	2.76	26.39	26.39	2.89	30.97	30.97	2.99	33.22	33.22	3.04	41.15	41.15	3.24						

LEGEND

Cap. — Heating Capacity (1000 Btuh) (Includes Indoor-Fan Motor Heat)

db — Dry Bulb

kW — Total Power Input (Includes Compressor Motor Power Input Outdoor-Fan Motor Input, and Indoor-Fan Motor Input)

rh — Relative Humidity

NOTES:

Integrated capacity is maximum (instantaneous) capacity less the effect of frost on the outdoor coil and the heat required to defrost it.

PERFORMANCE DATA-STANDARD X-13 INDOOR MOTOR

Cooling Extended Performance Table

PHN560 High Cool

EVAPORATOR AIR		CONDENSER ENTERING AIR TEMPERATURES deg F																	
		75 (23.8°C)			85 (29.4°C)			95 (35°C)			105 (40.5°C)			115 (46.1°C)			125 (51.6°C)		
		CFM	EWB	Total System KW	Capacity MBtuh	Total System KW	Capacity MBtuh	Total System KW	Capacity MBtuh	Total System KW	Capacity MBtuh	Total System KW	Capacity MBtuh	Total System KW	Capacity MBtuh	Total System KW	Capacity MBtuh	Total System KW	
	57	58.24	4.41	55.10	55.10	4.84	54.80	54.80	4.69	52.40	52.40	5.23	46.70	46.70	6.40	42.90	42.90	7.02	
	62	58.46	4.42	55.79	55.79	4.84	55.36	55.36	4.69	52.73	52.73	5.23	46.94	46.94	6.40	43.20	43.20	7.02	
2000	63	59.23	4.33	4.42	56.27	42.07	4.85	55.68	41.83	4.89	52.48	40.49	5.22	45.80	37.74	6.37	41.56	36.02	6.97
	67	63.56	44.86	4.50	60.35	43.59	4.92	56.88	42.24	5.38	56.82	42.14	5.33	48.97	39.21	6.44	44.37	37.49	7.05
	72	69.55	35.33	4.59	66.01	34.07	5.02	62.20	32.73	5.48	58.07	31.30	5.99	53.51	29.74	6.54	48.46	28.03	7.15
	57	56.01	56.01	4.29	53.76	53.76	4.72	51.30	51.30	5.19	50.80	50.80	5.08	45.20	45.20	6.27	41.70	41.70	6.89
	62	57.19	50.62	4.31	54.45	49.37	4.73	51.51	48.01	5.19	50.93	47.74	5.08	45.50	45.50	6.27	41.99	41.99	6.89
1750	63	58.18	40.75	4.32	55.35	39.51	4.74	52.28	38.20	5.20	51.66	37.95	5.10	45.27	35.27	6.26	41.16	33.59	6.87
	67	62.48	42.11	4.39	59.41	40.86	4.81	57.00	39.90	5.18	55.71	39.39	5.21	48.47	36.58	6.34	44.00	34.88	6.94
	72	68.41	33.69	4.48	65.01	32.46	4.91	61.35	31.14	5.37	57.37	29.72	5.88	52.97	28.19	6.44	48.09	26.53	7.04

PHN560 Low Cool

EVAPORATOR AIR		CONDENSER ENTERING AIR TEMPERATURES deg F																	
		75 (23.8°C)			85 (29.4°C)			95 (35°C)			105 (40.5°C)			115 (46.1°C)			125 (51.6°C)		
		CFM	EWB	Total System KW	Capacity MBtuh	Total System KW	Capacity MBtuh	Total System KW	Capacity MBtuh	Total System KW	Capacity MBtuh	Total System KW	Capacity MBtuh	Total System KW	Capacity MBtuh	Total System KW	Capacity MBtuh	Total System KW	
	57	39.88	39.88	2.70	38.34	38.34	3.04	36.64	36.64	3.43	34.74	34.74	3.87	31.90	31.90	4.37	29.70	29.70	4.94
	62	40.94	35.96	2.69	39.01	35.09	3.04	36.90	34.14	3.43	34.90	34.90	3.87	32.60	32.60	4.37	30.16	30.16	4.94
1200	63	41.76	29.14	2.69	39.78	28.27	3.04	37.61	27.34	3.42	35.23	26.33	3.87	32.61	25.22	4.37	29.69	24.04	4.96
	67	45.04	30.17	2.68	42.87	29.29	3.02	40.50	28.35	3.40	37.91	27.31	3.84	35.04	26.21	4.33	31.84	25.00	4.90
	72	49.59	24.40	2.68	47.18	23.52	3.01	44.52	22.56	3.38	41.68	21.55	3.80	38.47	20.43	4.28	34.93	19.21	4.84
	57	41.69	41.69	2.72	40.00	40.00	3.07	37.90	37.90	3.45	35.45	35.45	3.89	33.62	33.62	4.38	30.90	30.90	4.95
	62	41.98	38.83	2.72	40.02	40.02	3.07	38.18	38.18	3.45	36.13	36.13	3.89	33.82	33.82	4.38	31.19	31.19	4.95
1370	63	42.72	31.09	2.72	40.63	30.20	3.07	38.35	29.24	3.45	35.86	28.21	3.89	33.13	27.09	4.40	30.10	25.87	4.98
	67	46.03	32.23	2.72	43.75	31.34	3.05	41.27	30.36	3.43	38.55	29.32	3.86	35.56	28.18	4.36	32.25	26.93	4.92
	72	50.62	25.68	2.71	48.09	24.78	3.04	45.37	23.83	3.41	42.32	22.77	3.83	39.01	21.64	4.31	35.34	20.40	4.86

PERFORMANCE DATA-STANDARD X-13 INDOOR MOTOR

Heating Extended Performance Table

PHN560 High Heat

INDOOR AIR		OUTDOOR COIL ENTERING AIR TEMPERATURES deg F (°C)																				
		-10 (-23.3)				0 (-17.7)				10 (-12.2)				17 (-8.3)				20 (-6.6)				
		Capacity MBtuh		Total System KW		Capacity MBtuh		Total System KW		Capacity MBtuh		Total System KW		Capacity MBtuh		Total System KW		Capacity MBtuh		Total System KW		
EDB	CFM	Total	Integ	Total	Integ	Total	Integ	Total	Integ	Total	Integ	Total	Integ	Total	Integ	Total	Integ	Total	Integ	Total	Integ	
60	1750	17.01	15.65	3.08	21.62	19.89	3.31	27.05	24.83	3.55	31.57	28.78	3.73	33.69	30.55	3.82						
	2000	17.24	15.86	3.12	21.87	20.13	3.34	27.37	25.12	3.57	31.93	29.11	3.74	34.08	30.90	3.83						
70	1750	16.62	15.29	3.40	21.22	19.53	3.65	26.51	24.33	3.91	30.80	28.08	4.10	32.92	29.86	4.19						
	2000	16.88	15.53	3.44	21.50	19.78	3.69	26.82	24.62	3.93	31.18	28.43	4.11	33.32	30.22	4.20						
80	1750	16.04	14.75	3.72	20.64	18.99	4.01	25.93	23.80	4.29	30.06	27.41	4.49	31.99	29.01	4.59						
	2000	16.31	15.01	3.77	20.95	19.27	4.04	26.26	24.11	4.31	30.42	27.74	4.50	32.41	29.39	4.59						

PHN560 High Heat (Cont.)

INDOOR AIR		OUTDOOR COIL ENTERING AIR TEMPERATURES deg F (°C)																				
		30 (-1.1)				40 (4.4)				47 (8.3)				50 (10)				60 (15.5)				
		Capacity MBtuh		Total System KW		Capacity MBtuh		Total System KW		Capacity MBtuh		Total System KW		Capacity MBtuh		Total System KW		Capacity MBtuh		Total System KW		
EDB	CFM	Total	Integ	Total	Integ	Total	Integ	Total	Integ	Total	Integ	Total	Integ	Total	Integ	Total	Integ	Total	Integ	Total	Integ	
60	1750	41.80	36.62	4.14	50.24	50.24	4.44	56.80	56.80	4.63	59.20	59.20	4.67	64.80	64.80	4.75						
	2000	41.90	36.71	4.12	50.80	50.80	4.36	56.90	56.90	4.40	59.50	59.50	4.42	65.10	65.10	4.50						
70	1750	40.71	35.67	4.52	49.81	49.81	4.91	56.00	56.00	5.13	58.75	58.75	5.26	63.56	63.56	5.44						
	2000	41.19	36.09	4.53	50.10	50.10	4.84	56.40	56.40	4.99	59.10	59.10	5.02	64.30	64.30	5.11						
80	1750	39.61	34.70	4.93	48.50	48.50	5.35	55.46	55.46	5.63	58.45	58.45	5.74	62.90	62.90	6.23						
	2000	40.12	35.15	4.92	48.79	48.79	5.29	55.90	55.90	5.56	58.90	58.90	5.66	63.50	63.50	5.78						

LEGEND

Cap.— Heating Capacity (1000 Btuh) (Includes Indoor-Fan Motor Heat)

db — Dry Bulb

kW — Total Power Input (Includes Compressor Motor Power Input Outdoor-Fan Motor Input, and Indoor-Fan Motor Input)

rh — Relative Humidity

NOTES:

Integrated capacity is maximum (instantaneous) capacity less the effect of frost on the outdoor coil and the heat required to defrost it.

PERFORMANCE DATA-STANDARD X-13 INDOOR MOTOR

Heating Extended Performance Table

PHN560 Low Heat

INDOOR AIR		OUTDOOR COIL ENTERING AIR TEMPERATURES deg F (°C)																				
		-10 (-23.3)				0 (-17.7)				10 (-12.2)				17 (-8.3)				20 (-6.6)				
		Capacity MBtuh		Total System KW		Capacity MBtuh		Total System KW		Capacity MBtuh		Total System KW		Capacity MBtuh		Total System KW		Capacity MBtuh		Total System KW		
EDB	CFM	Total	Integ	Total	Integ	Total	Integ	Total	Integ	Total	Integ	Total	Integ	Total	Integ	Total	Integ	Total	Integ	Total	Integ	
60	1200	9.91	9.11	2.55	13.43	12.36	2.64	17.58	16.14	2.72	20.92	19.07	2.78	22.45	20.36	2.81						
	1370	10.02	9.22	2.55	13.56	12.48	2.62	17.73	16.28	2.69	21.10	19.23	2.74	22.64	20.54	2.76						
70	1200	9.46	8.70	2.89	12.98	11.94	2.99	17.10	15.69	3.08	20.40	18.60	3.15	21.92	19.88	3.18						
	1370	9.59	8.82	2.89	13.13	12.08	2.97	17.29	15.87	3.05	20.61	18.79	3.10	22.14	20.08	3.13						
80	1200	8.82	8.11	3.25	12.35	11.36	3.36	16.47	15.12	3.46	19.75	18.01	3.54	21.27	19.29	3.57						
	1370	8.96	8.24	3.25	12.52	11.52	3.34	16.67	15.30	3.43	19.98	18.22	3.49	21.51	19.51	3.52						

PHN560 Low Heat (Cont.)

INDOOR AIR		OUTDOOR COIL ENTERING AIR TEMPERATURES deg F (°C)																				
		30 (-1.1)				40 (4.4)				47 (8.3)				50 (10)				60 (15.5)				
		Capacity MBtuh		Total System KW		Capacity MBtuh		Total System KW		Capacity MBtuh		Total System KW		Capacity MBtuh		Total System KW		Capacity MBtuh		Total System KW		
EDB	CFM	Total	Integ	Total	Integ	Total	Integ	Total	Integ	Total	Integ	Total	Integ	Total	Integ	Total	Integ	Total	Integ	Total	Integ	
60	1200	28.14	24.66	2.91	35.04	35.04	3.03	40.62	40.62	3.13	43.31	43.31	3.18	53.58	53.58	3.38						
	1370	28.41	24.90	2.84	35.43	35.43	2.94	41.18	41.18	3.03	43.95	43.95	3.07	54.06	54.06	3.19						
70	1200	27.54	24.13	3.28	34.06	34.06	3.40	39.50	39.50	3.51	42.04	42.04	3.56	51.83	51.83	3.77						
	1370	27.81	24.37	3.21	34.46	34.46	3.31	40.01	40.01	3.40	42.63	42.63	3.44	52.74	52.74	3.62						
80	1200	26.82	23.50	3.69	33.24	33.24	3.82	38.34	38.34	3.92	40.91	40.91	3.99	50.19	50.19	4.21						
	1370	27.11	23.76	3.61	33.60	33.60	3.71	38.85	38.85	3.80	41.41	41.41	3.85	51.04	51.04	4.04						

LEGEND

Cap. — Heating Capacity (1000 Btuh) (Includes Indoor-Fan Motor Heat)

db — Dry Bulb

kW — Total Power Input (Includes Compressor Motor Power Input Outdoor-Fan Motor Input, and Indoor-Fan Motor Input)

rh — Relative Humidity

NOTES:

Integrated capacity is maximum (instantaneous) capacity less the effect of frost on the outdoor coil and the heat required to defrost it.

ACCESSORIES

ROOF CURBS

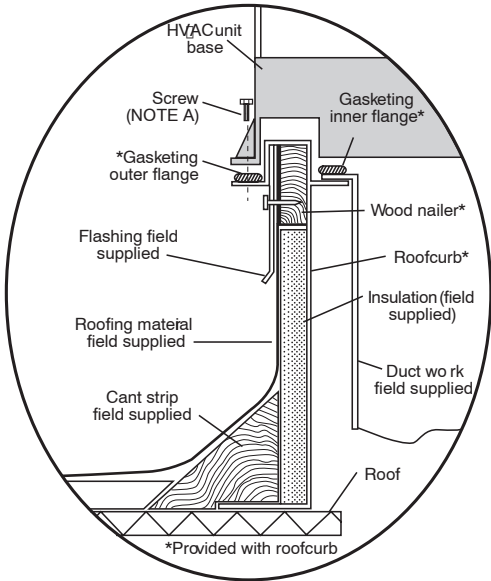

Roof Curb for Small Cabinet

Note A: When unit mounting screw is used retainer bracket must also be used.

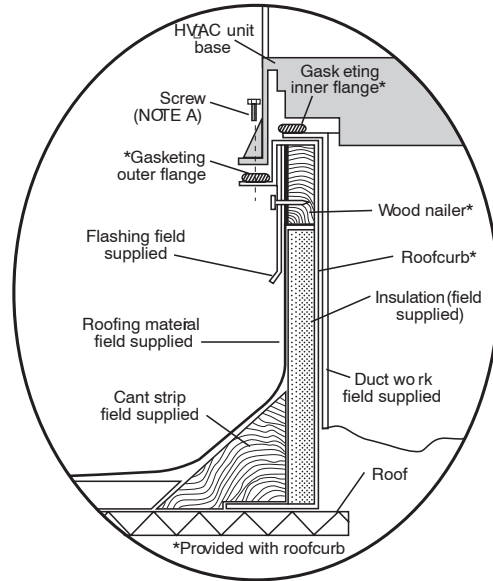

Roof Curb for Large Cabinet

Note A: When unit mounting screw is used retainer bracket must also be used.

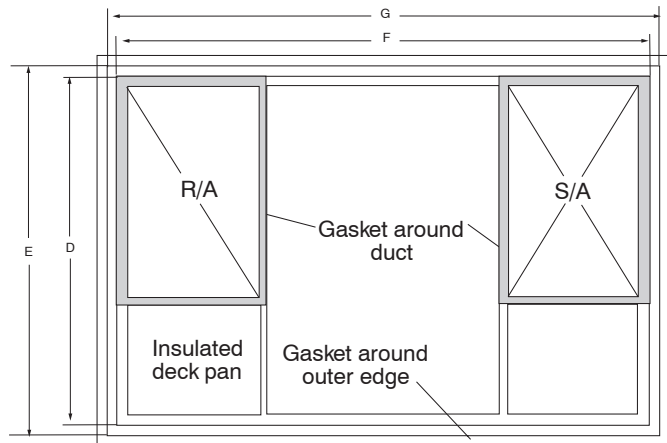
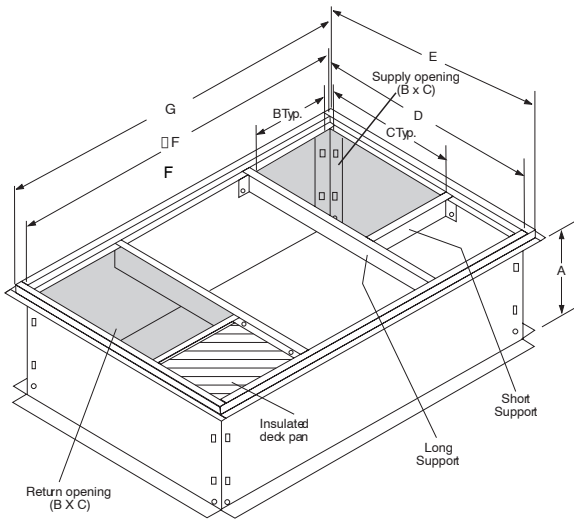

Model PHN5	MODEL NUMBER	A IN. [MM]	B IN. [MM]	C IN. [MM]	D IN. [MM]	E IN. [MM]	F IN. [MM]	G IN. [MM]
24	NPRFCURB006A00	8 [203]	11 [279]	16-1/2 [419]	28-3/4 [730]	30-3/8 [771]	44-5/16 [1126]	45-15/16 [1167]
	NPRFCURB007A00	14 [356]	11 [279]	16-1/2 [419]	28-3/4 [730]	30-3/8 [771]	44-5/16 [1126]	45-15/16 [1167]
36-60	NPRFCURB008A00	8 [203]	16-3/16 [411]	17-3/8 [441]	40-1/4 [1022]	41-15/16 [1065]	44-7/16 [1129]	46-1/16 [1169]
	NPRFCURB009A00	14 [356]	16-3/16 [411]	17-3/8 [441]	40-1/4 [1022]	41-15/16 [1065]	44-7/16 [1129]	46-1/16 [1169]

Notes:

1. Seal strip must be applied as required to unit being installed.
2. Roof curb is made of 16 gauge steel.
3. Attach ductwork to curb (flanges of duct rest on curb).
4. Insulated panels: 1-in. thick fiberglass 1 lb. density.
5. When unit mounting screw is used (see Note A), a retainer bracket must be used as well. This bracket must also be used when required by code for hurricane or seismic conditions. This bracket is available through Micrometl.

ACCESSORIES

MANUAL FRESH AIR DAMPERS (use in DOWNFLOW application only) *

Model Number	Control	Use With Model Size
NPMANDPR004A00	Manual	24
NPMANDPR005A00		36
NPMANDPR006A00		48, 60

* Unit must have internal filters to protect evaporator coil when Fresh Air Damper is installed.
All Manual Fresh Air Dampers shipped with Filter Racks but without Filters.

FILTER RACK and FILTER (shipped with 1" filters)

Model Number	Application	Filter Size	Use With Model Size
NPFILTRK004A00	Horizontal or Downflow	12" x 20" x 1" (quan. 2) or 12" x 20" x 2" (quan. 1) PLUS 10" x 20" x 2" (quan.1)	24
NPFILTRK005A00		12" x 24" x 1" or 2" (3 required)	36
NPFILTRK006A00		12" x 24" x 1" or 2" (3 required)	48, 60

CONCENTRIC ADAPTER

Model Number	Description	Use With Model Size
AXB030CAA	Adapts downflow openings thru the curb into round duct (18" dia.)	ALL

CONCENTRIC DIFFUSER

Model Number	Description	Use With Model Size
AXB030CSA	STEP DOWN - Adapts round duct (18" dia.) to ceiling diffuser	ALL
AXB030CFA	FLUSH MOUNT - Adapts round duct (18" dia.) to ceiling diffuser	ALL

SQUARE to ROUND TRANSITION

Model Number	Round Size	Square Size	Use With Model Size
NPDUFCFLG002A00	14"	14" x 16"	24, 36, 48, 60

PTC COMPRESSOR START ASSIST KIT

Model Number	Description	Use With Model Size
NPHSTART001A00	PTC type compressor start assist	ALL

LIFTING / RIGGING KIT

Model Number	Description	Use With Model Size
NPLIFTBK003A10	Lifting / Rigging Kit (Set of 10)	ALL

UNIT DIMENSIONS, model sizes 24

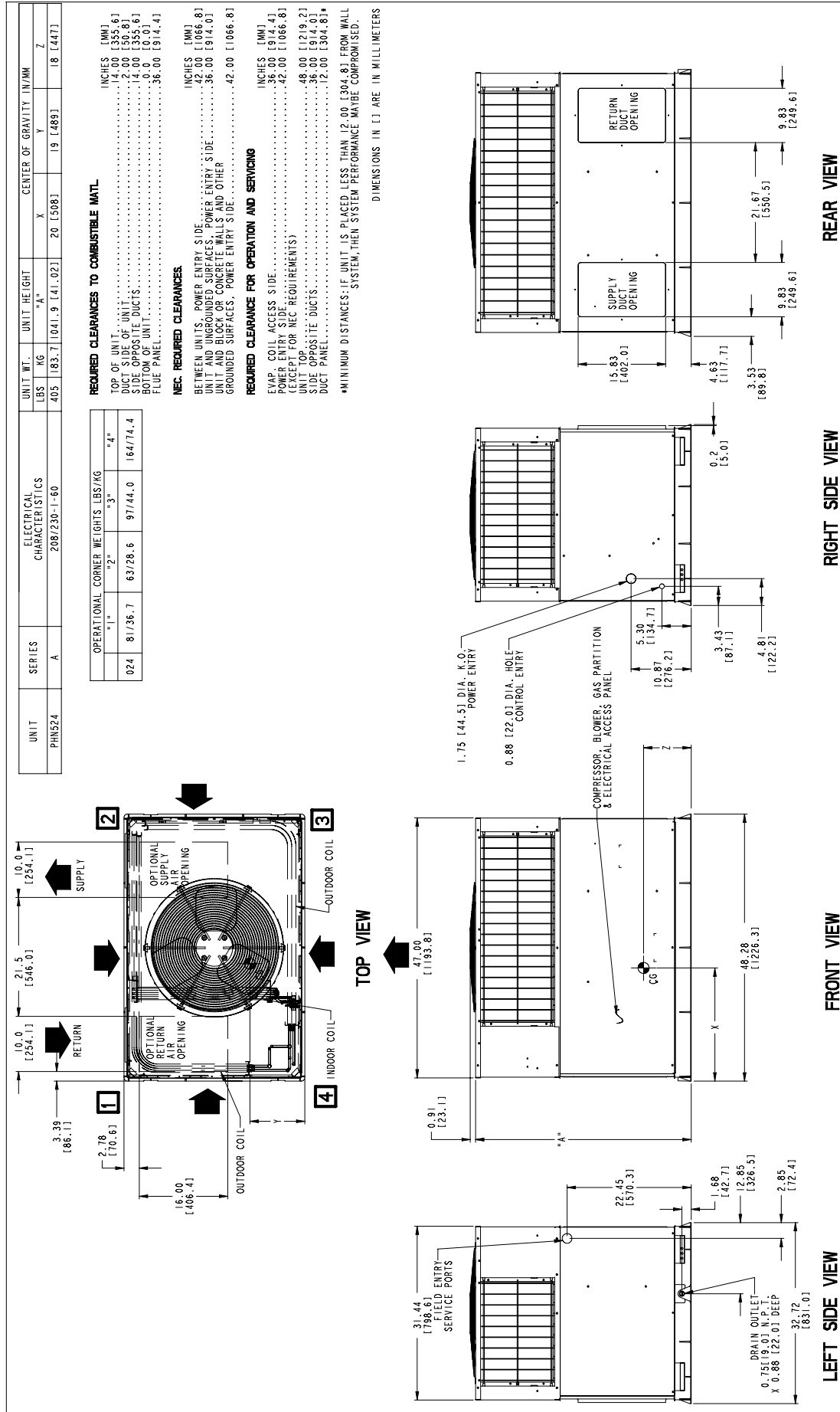

UNIT DIMENSIONS, model sizes 36 - 60

UNIT	SERIES	ELECTRICAL CHARACTERISTICS	UNIT WT.			UNIT HEIGHT			CENTER OF GRAVITY IN/MM			
			LBS	KG	"A"	"A"	X	Y	Z			
PHN536	A	208/230-1-60	464	[210.5]	44.98	[1142.5]	21	[533]	21	[537.1]	17	[422.1]
PHN548	A	208/230-1-60	492	[223.2]	46.98	[1183.3]	20	[493]	21	[534]	18	[457.1]
PHN560	A	208/230-1-60	535	[242.7]	50.98	[1284.9]	21	[533]	20	[508]	18	[447.1]

OPERATING CORNER WEIGHTS LBS/KG	"2"		"3"		"4"	
	"1"	"2"	"1"	"2"	"1"	"2"
036	93/42	72/33	112/51	187/85		
048	104/47	65/30	135/61	188/85		
060	115/52	75/34	146/66	189/90		

REQUIRED CLEARANCES TO COMBUSTIBLE MATL.

	INCHES [MM]
TOP OF UNIT.....	14.00 [355.6]
DUCT SIDE OF UNIT.....	2.00 [50.8]
SIDE OPPOSITE DUCTS.....	4.00 [101.6]
BOTTOM OF UNIT.....	36.00 [914.4]
ELECTRIC HEAT PANEL.....	36.00 [914.4]
NEC. REQUIRED CLEARANCES.	
BETWEEN UNITS, POWER ENTRY SIDE.....	42.00 [1066.8]
UNIT AND BLOCK OR CONCRETE WALLS AND OTHER GROUNDED SURFACES, POWER ENTRY SIDE.....	36.00 [914.4]
REQUIRED CLEARANCE FOR OPERATION AND SERVICING	
EVAP. COIL ACCESS SIDE.....	18.00 [457.1]
POWER ENTRY SIDE.....	42.00 [1066.8]
(EXCEPT FOR NEC REQUIREMENTS)	
UNIT TOP.....	48.00 [1219.2]
SIDE OPPOSITE DUCTS.....	36.00 [914.4]
DUCT PANEL.....	12.00 [304.8]

TOP VIEW

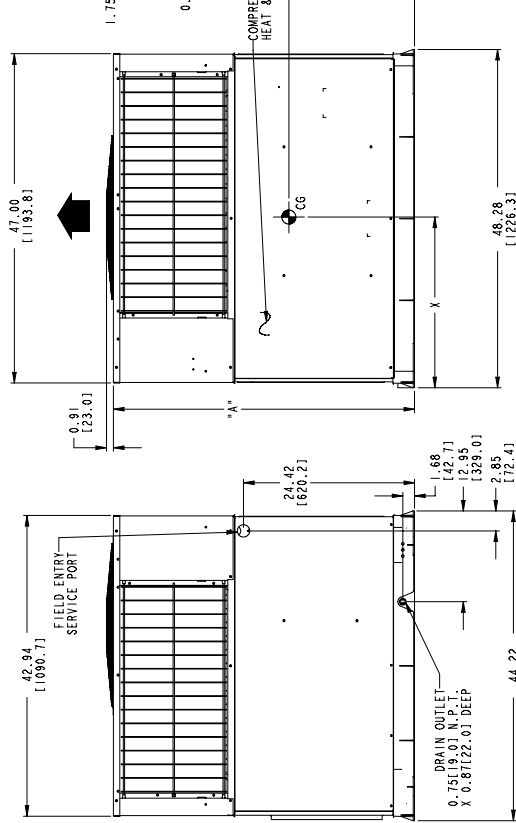
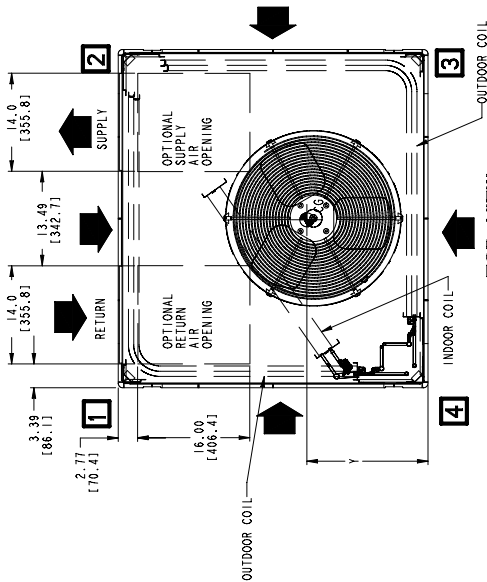

REAR VIEW

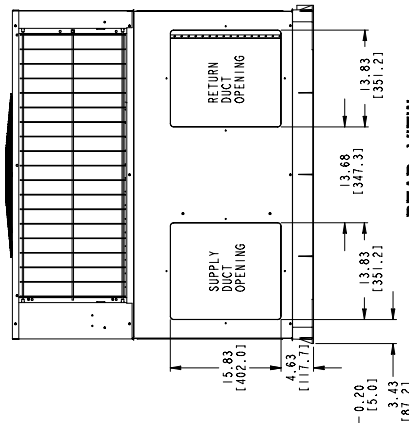

RIGHT SIDE VIEW

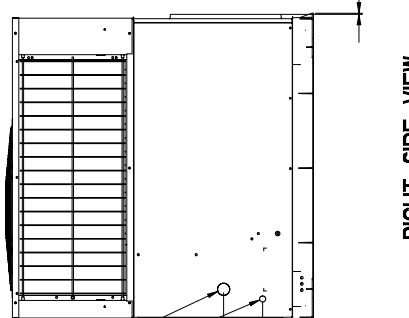

FRONT VIEW

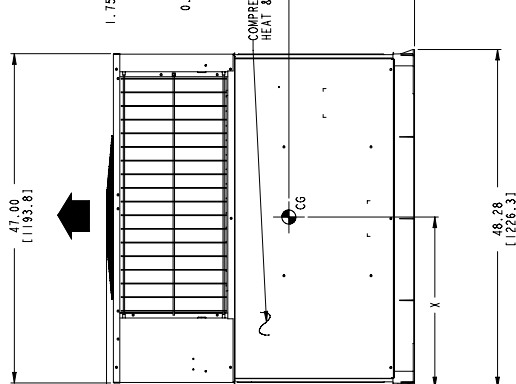

LEFT SIDE VIEW

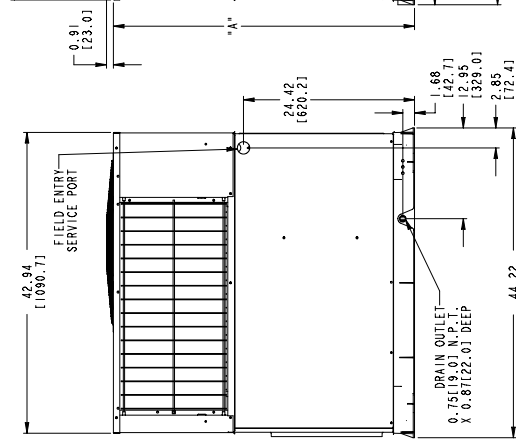

DIMENSIONS IN [] ARE IN MILLIMETERS

TOP VIEW

GUIDE SPECIFICATIONS

CABINET

Unit cabinet shall be constructed of phosphated, zinc-coated, pre-painted steel capable of with-standing 500 hours in salt spray. Normal service shall be through a single removable cabinet panel.

The unit shall be constructed on a rust proof unit base that has an externally trapped, integrated sloped drain.

Evaporator fan compartment top surface shall be insulated with a minimum 1/2-in. thick, flexible fiberglass insulation, coated on the air side and retained by adhesive and mechanical means. The evaporator wall sections will be insulated with a minimum semi-rigid foil-faced board capable of being wiped clean. Aluminum foil-faced fiberglass insulation shall be used in the entire indoor air cavity section.

COOLING SECTION

The unit is factory charged and operationally ready upon delivery. The unit refrigerant circuit has a high efficiency scroll compressor with internal overload protection, and copper tube / aluminum fin evaporator and condenser coils. The unit has a minimum ambient operating temperature of 55° F (12.7°C). Maximum outdoor operating air temperature for cooling is 125° F (51.6°C).

COILS

The evaporator and condenser coils are fabricated with aluminum fins mechanically bonded to copper tubing. Both coils are pressure tested prior to assembly into the unit and electronically leak tested after assembly into the unit.

CONDENSER FAN

The unit has a single direct-drive propeller-fan / motor assembly. The assembly is mounted directly to a vertical-discharge grille that is easily removed for service. Motors are 825 RPM or 1100 RPM with sleeve or ball bearings and internal overload protection.

EVAPORATOR BLOWER

All units have a direct-drive X-13 evaporator blower motor as a standard. The direct-drive evaporator blower motor has sleeve bearings and internal overload protection.

CORNER WEIGHTS and RIGGING DETAILS

FIGURE 1

Unit Corner Weight and Rigging

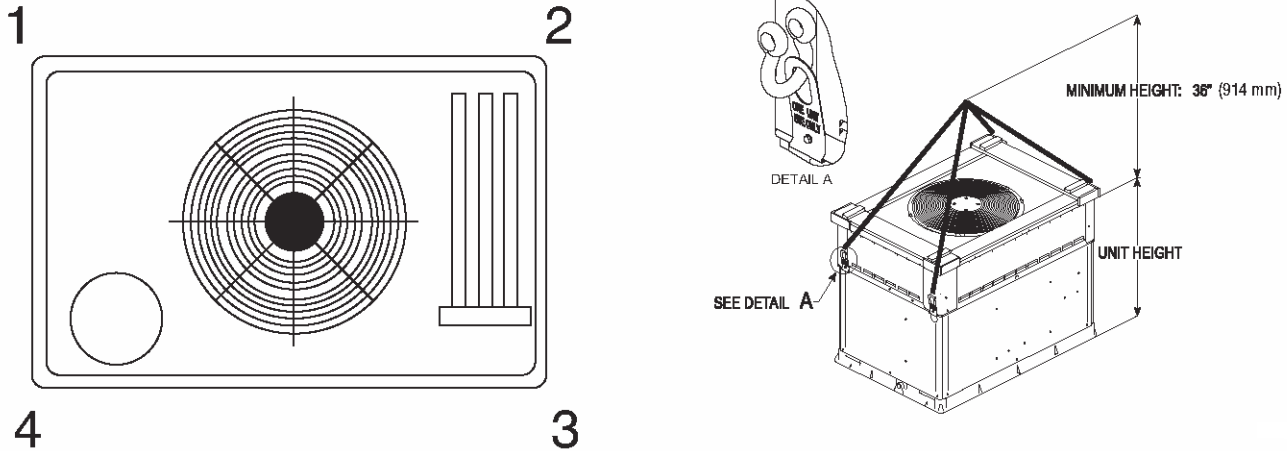

Cabinet	MODEL NUMBER	Rigging Weight		1		2		3		4	
		lb	kg	lb	kg	lb	kg	lb	kg	lb	kg
Small	PHN524	382	173	75	34	57	26	91	41	158	72
Large	PHN536	469	213	93	42	71	32	113	51	192	87
	PHN548	497	225	104	47	63	29	136	62	193	88
	PHN560	548	249	117	53	75	34	149	68	207	94

MODEL NUMBER IDENTIFICATION GUIDE

Product Family	SEER	Nominal Cooling Capacity BTU/h	Heating Input BTU/h	Voltage	Option Code	Design Code	Eng. Rev. Code
PHN - Package Heat Pump	5 = 15	24 = 24,000 36 = 36,000 48 = 48,000 60 = 60,000	000 = N/A	K = 208/230-1-60	00 = N/A	A	1
Example: PHN	5	24	000	K	00	A	1