

CRNGELEV001A00
CRNGELEV002A00
CRLPELEV005A00
CRLPELEV006A00
CRLPKIT9001A00

PACKAGED ROOFTOP UNITS with R-410A
ACCESSORY PROPANE and
HIGH ALTITUDE GAS CONVERSION KIT
GAS HEATING/ELECTRIC COOLING
176,000–400,000 Btu/hr HEATING

Installation Instructions

TABLE OF CONTENTS

PACKAGE CONTENTS	1	HIGH ALTITUDE NATURAL GAS CONVERSION KIT INSTALLATION	8
SAFETY CONSIDERATIONS	3	Step 1 - Remove Gas Manifold from Base Unit	8
GENERAL	3	Step 2 - Modify Gas Manifold Assembly	8
STANDARD/HIGH ALTITUDE PROPANE CONVERSION KIT INSTALLATION	4	Step 3 - Re-install Gas Manifold Assembly	8
Step 1 - Remove Gas Manifold from Base Unit	4	Step 4 - Check Unit Operation and Make Necessary Adjustments	8
Step 2 - Modify Gas Manifold/Valve Assembly	5		
Step 3 - Re-install Gas Manifold/Valve Assembly ...	6		
Step 4 - Check Unit Operation and Make Necessary Adjustments	7		

IMPORTANT: Read these instructions completely before attempting to install this accessory.

Table 1 – Package Usage

Model	Unit Size
48HC	17–28
48TC	17–30
48LC	14–26

Model	Size
580J	17–30
581J	17–28

Model	Size
RGS	210–336
RGH	181–303

PACKAGE CONTENTS TABLES HIGH ALTITUDE AND PROPANE KITS

CRNGELEV001A00		High Altitude – Natural Gas Kit (3000 – 10000 ft.)	
ITEM	COMPONENT NUMBER	QTY	COMPONENT NAME
1	IJK–CRLPNGE01–02	1	INSTRUCTIONS, INSTALLATION
2	LH32RF120 (#31)	9	ORIFICE, BURNER
3	LH32RF116 (#32)	9	ORIFICE, BURNER
4	LH32RF111 (#34)	9	ORIFICE, BURNER
5	48TM501015	1	LABEL, HIGH–ALTITUDE RESPONSIBILITY
6	50HE501331	1	LABEL, CONVERSION KIT RATING PLATE

CRNGELEV002A00		High Altitude – Natural Gas Kit (10000 – 14000 ft.)	
ITEM	COMPONENT NUMBER	QTY	COMPONENT NAME
1	IJK–CRLPNGE01–02	1	INSTRUCTIONS, INSTALLATION
2	LH32RF110 (#35)	9	ORIFICE, BURNER
3	LH32RF104 (#37)	9	ORIFICE, BURNER
4	LH32RF103 (#39)	9	ORIFICE, BURNER
5	48TM501015	1	LABEL, HIGH–ALTITUDE RESPONSIBILITY
6	50HE501331	1	LABEL, CONVERSION KIT RATING PLATE

CRLPELEV005A00		High Altitude – Propane Kit (2000 – 10000 ft.)	
ITEM	COMPONENT NUMBER	QTY	COMPONENT NAME
1	IJK–CRLPNGE01–02	1	INSTRUCTIONS, INSTALLATION
2	LH32RF073 (#49)	9	ORIFICE, BURNER
3	LH32RF070 (#50)	9	ORIFICE, BURNER
4	LH32RF067 (#51)	9	ORIFICE, BURNER
5	CA01CA014	1	NIPPLE, 1/8" PIPE X 2 1/2"
6	HK02LB008	1	SWITCH, PROPANE PRESSURE
7	99MG737XC201018	1	WIRE, BROWN
8	EF39ZW023	2	SPRINGS, PROPANE CONVERSION
9	48TM501012	1	LABEL, UNIT WARNING
10	48TM501013	1	LABEL, PROPANE CONVERSION
11	48TM501014	1	LABEL, PROPANE RESPONSIBILITY
12	50HE501340	1	LABEL, CONVERSION KIT RATING PLATE

CRLPELEV006A00		High Altitude – Propane Kit (10000 – 14000 ft.)	
ITEM	COMPONENT NUMBER	QTY	COMPONENT NAME
1	IJK–CRLPNGE01–02	1	INSTRUCTIONS, INSTALLATION
2	LH32RF065 (#52)	9	ORIFICE, BURNER
3	LH32RF060 (#53)	9	ORIFICE, BURNER
4	CA01CA014	1	NIPPLE, 1/8" PIPE X 2 1/2"
5	HK02LB008	1	SWITCH, PROPANE PRESSURE
6	99MG737XC201018	1	WIRE, BROWN
7	EF39ZW023	2	SPRINGS, PROPANE CONVERSION
8	48TM501012	1	LABEL, UNIT WARNING
9	48TM501013	1	LABEL, PROPANE CONVERSION
10	48TM501014	1	LABEL, PROPANE RESPONSIBILITY
11	50HE501340	1	LABEL, CONVERSION KIT RATING PLATE

CRLPKIT9001A00		Standard Altitude – Propane Kit (0 – 2000 ft.)	
ITEM	COMPONENT NUMBER	QTY	COMPONENT NAME
1	IJK–CRLPNGE01–02	1	INSTRUCTIONS, INSTALLATION
2	LH32RF076 (#48)	9	ORIFICE, BURNER
3	CA01CA014	1	NIPPLE, 1/8" PIPE X 2 1/2"
4	HK02LB008	1	SWITCH, PROPANE PRESSURE
5	99MG737XC201018	1	WIRE, BROWN
6	EF39ZW023	2	SPRINGS, PROPANE CONVERSION
7	48TM501012	1	LABEL, UNIT WARNING
8	48TM501013	1	LABEL, PROPANE CONVERSION
9	48TM501014	1	LABEL, PROPANE RESPONSIBILITY

SAFETY CONSIDERATIONS

Installation and servicing of air-conditioning equipment can be hazardous due to system pressure and electrical components. Only trained and qualified service personnel should install, repair, or service air-conditioning equipment.

Untrained personnel can perform the basic maintenance functions. All other operations should be performed by trained service personnel. When working on air-conditioning equipment, observe precautions in the literature, tags and labels attached to the unit, and other safety precautions that may apply.

Follow all safety codes. Wear safety glasses and work gloves.

Recognize safety information. This is the safety-alert symbol . When you see this symbol on the unit and in instructions or manuals, be alert to the potential for personal injury.

Understand the signal words DANGER, WARNING, and CAUTION. These words are used with the safety-alert symbol. DANGER identifies the most serious hazards which **will** result in severe personal injury or death. WARNING signifies a hazard which **could** result in personal injury or death. CAUTION is used to identify unsafe practices which **may** result in minor personal injury or product and property damage. NOTE is used to highlight suggestions which **will** result in enhanced installation, reliability, or operation.

GENERAL

These models are shipped from the factory equipped to operate with natural gas at elevations up to 3000 ft (914 m). The units must be modified if installed at elevations above 3000 ft (914 m) using natural gas, or if operated with propane at any altitude.

For installations in Canada, the unit rating must be derated by 10% for altitudes of 2000 ft (610 m) to 4500 ft (1372 m) above sea level.

Five different gas conversion kits are available, as shown in Package Contents tables (see pages 1 and 2). Each kit contains a particular range of orifice sizes plus other hardware and labels necessary for converting the unit. Refer to the Altitude Compensation table (at the end of this document) to determine the recommended orifice size based on fuel type and elevation.

WARNING

FIRE, EXPLOSION, CARBON MONOXIDE POISONING, PROPERTY DAMAGE HAZARD

Failure to follow this warning could result in personal injury, death or property damage.

This conversion kit shall be installed by a qualified service agency in accordance with the manufacturer's instructions and all applicable codes and requirements of the authority having jurisdiction. The qualified service agency is responsible for the proper installation of this kit. The installation is not proper and complete until the operation of the converted furnace is checked as specified in the manufacturer's instructions supplied in the kit.

AVERTISSEMENT

FEU, EXPLOSION, EMPOISONNEMENT PAR CARBON DE MONOXYDE, RISQUE DE DOMMAGE À LA PROPRIÉTÉ

La négligence de suivre l'avis suivant, peut causer des blessures personnelles, la mort ou du dommage à la propriété.

Cette trousse de conversion doit être installée par un Entrepreneur qualifié, selon les instructions du fabricant et doit se conformer à toutes les exigences et tout les codes pertinents de l'autorité compétente. L'Entrepreneur qualifié est responsable, et doit s'assurer de bien suivre les instructions dans cet avis. L'installation sera considérée conforme et rencontrant les spécifications et instructions du fabricant qui sont inclus dans la trousse, seulement après vérification de l'opération de la fournaise convertie.

⚠ WARNING

EXPLOSION, PERSONAL INJURY HAZARD

Failure to follow this warning could result in personal injury or death.

Unit is designed to operate at 10.0 in. we of manifold pressure on HIGH stage and 6.6 in. we on LOW stage with PROPANE gas.

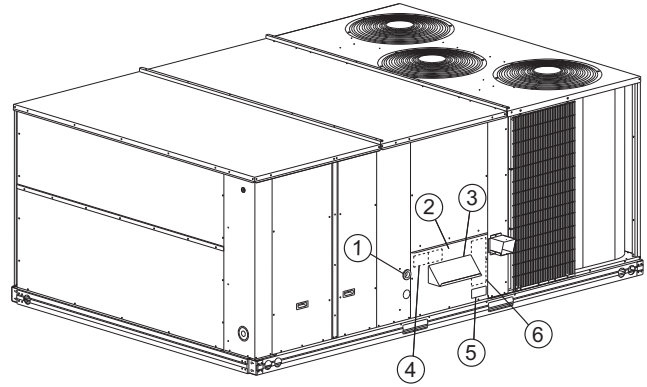

C09394

Item No.	Description
1	Gas Inlet
2	Burner Access Panel
3	Inlet Air Hood
4	Propane Responsibility Label or High Altitude Responsibility Label (If specified, apply label to back side of panel)
5	Warning Label (apply label to outside of panel)
6	Conversion Kit Rating Plate Label (If specified, apply label to back side of panel)

Fig. 1 - Typical Base Unit

⚠ WARNING

FIRE, EXPLOSION, ELECTRICAL HAZARD

Failure to follow this warning could result in personal injury, death or property damage.

Gas supply **MUST** be shut off before disconnecting electrical power and proceeding with conversion

⚠ WARNING

ELECTRICAL SHOCK HAZARD

Failure to follow this warning could result in personal injury or death.

Before installing or servicing system, always turn off main power to system. There may be more than one disconnect switch. Tag disconnect switch with suitable warning label.

STANDARD/HIGH ALTITUDE PROPANE CONVERSION KIT INSTALLATION

Step 1 — Remove Gas Manifold Assembly from Base Unit

1. Shut off main gas supply to unit.
2. Shut off power to unit and install lockout tag.
3. Remove burner access panel.
4. Disconnect gas piping to allow removal of gas manifold.
5. Disconnect and mark wires to gas valve and cut wire ties holding wire bundle to gas manifold.
6. Remove the 2 screws on each end of the gas manifold that attached it to the sheet metal side brackets. (See Fig. 2, Item 1.)
7. Remove the gas manifold assembly with the gas valve attached.

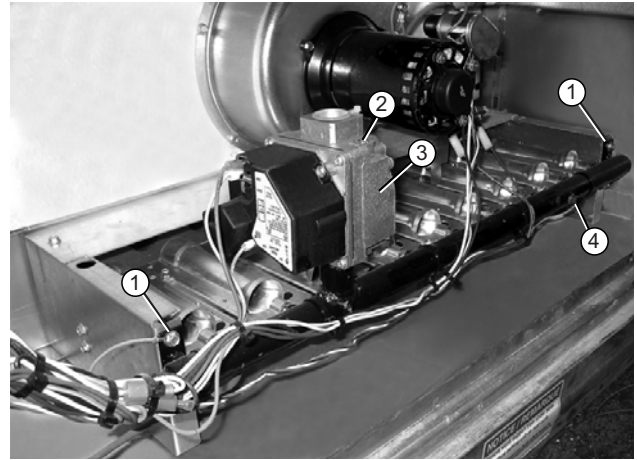

C09395

Item No.	Description
1	Gas Manifold Mounting Screws (qty 2)
2	Gas Valve Inlet Plug
3	Propane Conversion Label (apply label where indicated)
4	Gas Manifold Pressure Tap

Fig. 2 - Gas Section Details

Step 2 — Modify Gas Manifold / Valve Assembly

1. Remove existing gas orifices. Install the new orifices (as shown in Fig. 3) from the gas conversion kit, making sure they match the recommended size from Table 2.

IMPORTANT: Never use Teflon tape to seal gas orifice threads because peeling tape can plug the orifice.

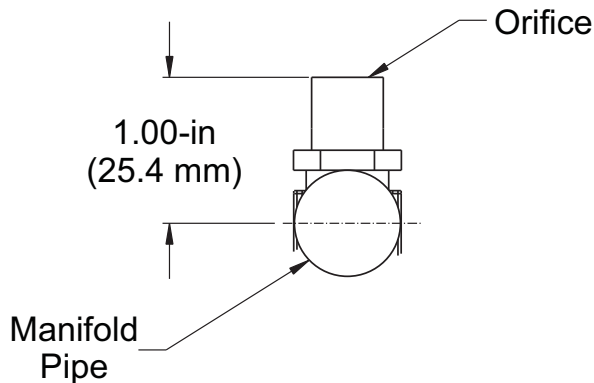
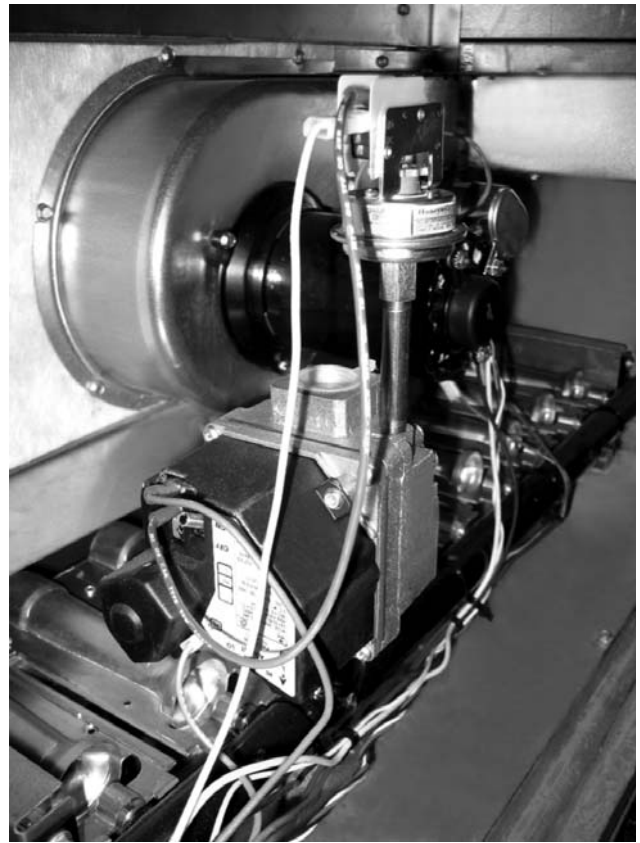

Fig. 3 - Orifice Projection

C08211

2. Remove the plug on the inlet end of the gas valve using a $\frac{3}{16}$ -in hex wrench. (See Fig. 2, Item 2.)
3. Install the $\frac{1}{8}$ -in x $2\text{-}\frac{1}{2}$ -in nipple where the plug was removed. (See Fig. 4.) Use pipe thread dope or tape (field supplied, must be certified for use with propane gas) for all joints, making sure not to get any excess in the pipe or valve. Next, install the Propane Pressure Switch as shown in Fig. 4.
4. Connect supplied brown jumper wire from terminal "C" on the pressure switch to terminal "MP" on the gas valve as shown in Fig. 4.
5. Remove regulator cover screws from gas regulators. (See Fig. 5.) Save regulator cover screws.
6. Using a screwdriver, remove plastic adjustment screws from both regulators. (See Fig. 5.) Save plastic adjustment screws.



C09396

Fig. 4 - Propane Pressure Switch Piping and Wiring

7. Remove regulator springs (silver) from gas regulators. (See Fig. 5.) Discard the regulator springs.
8. Install propane gas regulator springs (white) shipped with the kit into the gas regulators. (See Fig. 5.)
9. Using the plastic adjust screws removed earlier, install one of the screws into the low stage gas regulator, turning it clockwise 13.5 turns. (See Fig. 5.) Install the remaining plastic adjust screw into the low stage gas regulator, turning it clockwise 9.5 turns. Replace regulator cover screws. (See Fig. 5.)

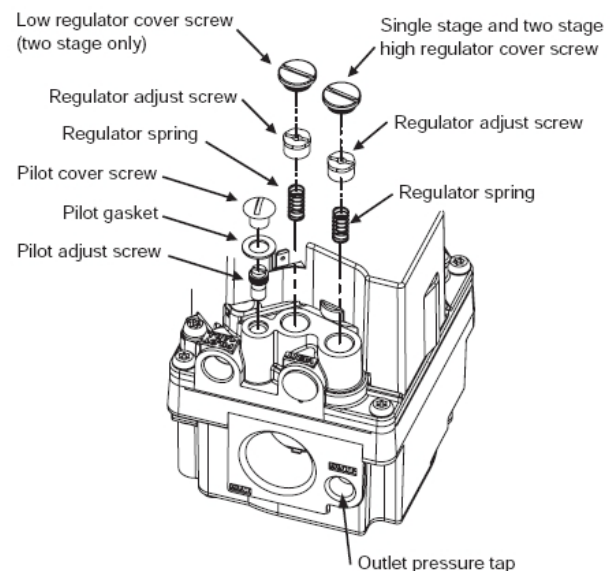
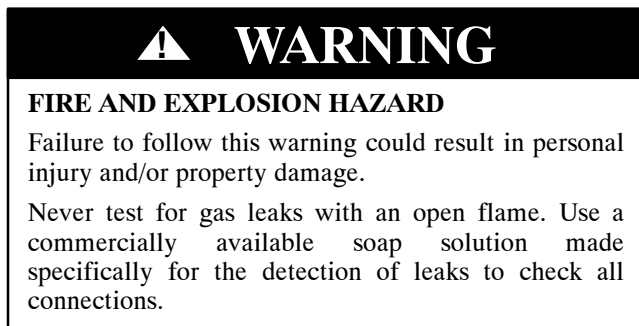

Fig. 5 - Two-Stage Spring Installation

C08241

Step 3 — Re-install Gas Manifold / Valve Assembly

1. Remount the gas manifold assembly to the sheet metal side brackets using 2 screws on each end; make sure that the gas orifices are all inserted into the burners. (See Fig. 2.)
2. Reconnect the wires to the gas valve, except for the grey wire. Connect the grey wire to the “NO” (Normally Open) terminal on the pressure switch.
3. Using wire ties reconnect the wire bundle to the gas manifold making sure that the spark ignitor wire is kept separate and away from the bundle.
4. Connect gas piping to the gas valve.
5. Attach Propane Conversion Label to gas valve. (See Fig. 2, Item 3 and Fig. 7.)
6. Attach Unit Warning Label to burner access panel. (See Fig. 1, Item 5 and Fig. 6.)
7. Attach completed Propane Responsibility Label to inside of burner access panel (See Fig. 1, Item 4 and Fig. 8.)
8. For High Altitude Propane installations attach Conversion Kit Rating Plate Label to inside of burner access panel. (See Fig. 1, Item 6 and Fig. 10.)
9. Leak check all gas connections including the main service connection, gas valve, gas spuds, and manifold pipe plug. All leaks must be repaired before firing unit. NOTE: Test pressure not to exceed $\frac{1}{2}$ psi (13.8-in wc).



The newly installed low gas pressure switch is a safety device used to guard against adverse burner operating characteristics that can result from low gas supply pressure. Switch opens at not less than 7.2-in. wc and closes at not greater than 10.2-in. wc.

This switch also prevents operation when the propane tank level is low which can result in gas with a high concentration of impurities, additives, and residues that have settled to the bottom of the tank. Operation under these conditions can cause harm to the heat exchanger system. This normally open switch closes when gas is supplied to gas valve under normal Propane operating pressure of 11.0 to 13.0-in.wc. The closed switch completes control circuit. Should an interruption or reduction in gas supply occur, the gas pressure at switch drops below low gas pressure switch setting, and switch opens. Any interruption in control circuit (in which low gas pressure switch is wired) quickly closes gas valve and stops gas flow to burners.



Fig. 6 - Unit Warning Label – Propane Only



Fig. 7 - Propane Conversion Label – Propane Only

<p>THIS FURNACE WAS CONVERTED ON _____ - _____ - _____ TO PROPANE GAS <small>DAY MONTH YEAR</small></p> <p>USING _____ ORIFICE SIZE.</p> <p>BY: _____</p> <p>_____</p> <p>_____</p> <p><small>(Name and address of organization making this conversion), which accepts the responsibility that this conversion has been properly made.</small></p> <p style="text-align: right;">48TM501014 REV-</p>	<p>CÉ GÉNÉRATEUR D'AIR CHAUD A ÉTÉ CONVERTI LE _____ - _____ - _____ POUR <small>JOUR MOIS ANNEE</small></p> <p>GAZ DE PÉTROLÉ LIQUÉFIE OU PROPANE SI L'ORIFICE EST INDENTIQUE AU TROU D'UN FORÉT N° PAR: _____</p> <p>_____</p> <p>_____</p> <p><small>(Nom et adresse de l'organisme qui a effectué la conversion), qui accepte l'entière responsabilité de la conversion.</small></p>
---	--

C08242

Fig. 8 - Propane Responsibility Label

Step 4 — Check Unit Operation and Make Necessary Adjustments

NOTE: Propane gas supply pressure must not be less than **11-in.wc** or greater than **13-in.wc** at the unit connection.

1. Remove gas manifold pressure tap plug and connect pressure gauge or manometer. (See Fig. 2, Item 4.)
2. Turn on electrical supply.
3. Turn on unit main gas valve.
4. Set room thermostat to call for heat. Verify high-stage heat operation before attempting to adjust manifold pressure.
5. When main burners ignite, check all fittings, manifold, and orifices for leaks.
6. Adjust high-stage pressure to 10.0-in. wc by turning the plastic adjust screw clockwise to increase pressure, or, counter-clockwise to decrease to pressure.
7. Set room thermostat to call for low-stage heat. Verify then adjust low-stage pressure to 6.6-in. wc.
8. Replace regulator cover screws when finished.
9. With burner access panel removed, observe unit heating operation in both high stage and low stage operation. Observe burner flames to see if they are blue in appearance, and that the flames are approximately the same for each burner.
10. Turn off unit, remove pressure manometer and replace the 1/8-in. pipe fitting on the gas manifold. (See Fig. 2, Item 4.)

WARNING

FIRE AND EXPLOSION HAZARD

Failure to follow this warning could result in personal injury and/or property damage.

Never test for gas leaks with an open flame. Use a commercially available soap solution made specifically for the detection of leaks to check all connections.

WARNING

ELECTRICAL SHOCK HAZARD

Failure to follow this warning could result in personal injury or death.

Before installing or servicing system, always turn off main power to system. There may be more than one disconnect switch. Tag disconnect switch with suitable warning label.

WARNING

FIRE, EXPLOSION AND ELECTRICAL SHOCK HAZARD

Failure to follow this warning could result in personal injury, death and/or property damage.

Gas supply **MUST** be shut off before disconnecting electrical power and proceeding with conversion.

HIGH ALTITUDE NATURAL GAS CONVERSION KIT INSTALLATION

Step 1 — Remove Gas Manifold Assembly from Base Unit

1. Shut off main gas supply to unit.
2. Shut off power to unit and install lockout tag.
3. Remove burner access panel.
4. Disconnect gas piping at unit gas valve.
5. Disconnect and mark wires to gas valve and cut wire ties holding wire bundle to gas manifold.
6. Remove the 2 screws on each end of the gas manifold that attached it to the sheet metal side brackets. (See Fig. 2, Item 1.)
7. Remove the gas manifold assembly with the gas valve attached.

Step 2 — Modify Gas Manifold Assembly

1. Remove existing gas orifices. Install the new orifices (as shown in Fig. 3) from the gas conversion kit, making sure they match the recommended size from Table 2.

IMPORTANT: Never use Teflon tape to seal gas orifice threads because peeling tape can plug the orifice.

Step 3 — Re-install Gas Manifold Assembly

1. Remount the gas manifold assembly to the sheet metal side brackets using 2 screws on each end; make sure that the gas orifices are all inserted into the burners. (See Fig. 2.)
2. Reconnect wires to gas valve.
3. Using wire ties reconnect the wire bundle to the gas manifold making sure that the spark ignitor wire is kept separate and away from the bundle.
4. Connect gas piping to the gas valve.

5. Attach completed High Altitude Responsibility Label to inside of service access panel. (See Fig. 1, Item 4 and Fig. 9.)
6. Attach Conversion Kit Rating Plate Label to inside of burner access panel. (See Fig. 1, Item 6 and Fig. 10.)
7. Leak check all gas connections including the main service connection, gas valve, gas spuds, and manifold pipe plug. All leaks must be repaired before firing unit. NOTE: Test pressure not to exceed $1/2$ psi (13.8-in wc).

Step 4 — Check Unit Operation and Make Necessary Adjustments

1. Remove manifold pressure tap plug and connect pressure gauge or manometer. (See Fig. 2, Item 4.)
2. Turn on electrical supply.
3. Turn on unit main gas valve.
4. Set room thermostat to call for heat. Verify high-stage heat operation before attempting to adjust manifold pressure.
5. When main burners ignite, check all fittings, manifold, and orifices for leaks.
6. Adjust high-stage pressure to 3.0-in. wc by turning the plastic adjust screw clockwise to increase pressure, or, counter-clockwise to decrease pressure.
7. Set room thermostat to call for low-stage heat. Verify then adjust low-stage pressure to 2.0-in. wc.
8. Replace regulator cover screw(s) when finished.
9. With burner access panel removed, observe unit heating operation in both high stage and low stage operation. Observe burner flames to see if they are blue in appearance, and that the flames are approximately the same for each burner.
10. Turn off unit, remove pressure manometer and replace the $1/8$ -in. pipe fitting on the gas manifold. (See Fig. 2, Item 4.)

<p>THIS FURNACE WAS CONVERTED ON _____ FOR OPERATION AT <small>DAY MONTH YEAR</small> _____ ft (_____)m ALTITUDE WITH KIT NO. _____ BY. _____ _____ _____ <small>(Name and address of organization making this conversion), which accepts the responsibility that this conversion has been properly made.</small> 48TM501015 REV-</p>	<p>CÉ GÉNÉRATEUR D'AIR CHAUD A ÉTÉ CONVERTI LE _____ POUR <small>JOUR MOIS ANNEE</small> UTILISATION Á UNE ALTITUDE DE _____pi (_____)m AU MOYEN DE LA TRO_USSE N°. _____ PAR. _____ _____ _____ <small>(Nom et adresse de l'organisme qui a effectué la conversion), qui accepte l'entnere responsabilité de la conversion.</small></p>
---	--

Fig. 9 - High-Altitude Responsibility Label

C08243

**CONVERSION KIT RATING PLATE
NATURAL GAS HIGH ALTITUDE**

APPLIES TO MODELS 48TC AND 48HC
REFER TO MAIN RATING PLATE FOR SPECIFIC MODEL NUMBER.
THIS UNIT HAS BEEN CONVERTED TO OPERATE WITH NATURAL GAS
AT ALTITUDES FROM 3,000 TO 14,000 FEET.
UNITS INSTALLED AT ALTITUDES BELOW 3,000 FEET DO NOT REQUIRE CONVERSION.
REFER TO KIT INSTRUCTIONS FOR CONVERSION PROCEDURES.

CONVERSION KIT PART NUMBERS:
CRNGELEV001A00 FOR 3,000 TO 10,000 FT. ELEVATION
CRNGELEV002A00 FOR 10,000 TO 14,000 FT. ELEVATION

MANIFOLD PRESSURE: 3.0 IN. W.C. HIGH STAGE
2.0 IN. W.C. LOW STAGE
MINIMUM GAS SUPPLY PRESSURE: 5.0 IN. W.C.
MAXIMUM GAS SUPPLY PRESSURE: 13.0 IN. W.C.

REFER TO ALTITUDE COMPENSATION TABLES FOUND IN KIT INSTRUCTIONS FOR
REQUIRED INFORMATION TO COMPLETE THIS SECTION.

INSTALLATION ALTITUDE _____ FT

ORIFICE SIZE INSTALLED _____

INPUT RATE AT INSTALLATION ALTITUDE _____ BTU/HR

FOR INSTALLATIONS IN CANADA, THE INPUT RATING SHOULD BE DERATED BY 10%
FOR ALTITUDES FROM 2,000 FT (610 M) TO 4,500 FT (1372 M) ABOVE SEA LEVEL.

**PLAQUE SIGNALÉTIQUE DE TROUSSE DE CONVERSION
GAZ NATUREL HAUTE ALTITUDE**

APPLICABLE AUX MODÈLES 48TC ET 48HC
SE RÉFÉRER À LA PLAQUE SIGNALÉTIQUE PRINCIPALE POUR LE NUMÉRO DE MODÈLE SPÉCIFIQUE
CET APPAREIL A FAIT L'OBJET D'UNE CONVERSION POUR UN FONCTIONNEMENT
AU GAZ NATUREL À DES ALTITUDES SITUÉES ENTRE 3 000 ET 14 000 PIEDS.
LES APPAREILS INSTALLÉS EN DESSOUS DE 3 000 PIEDS NE NÉCESSITENT PAS DE CONVERSION.
SE RÉFÉRER AUX INSTRUCTIONS FOURNIES AVEC LA TROUSSE POUR OBTENIR LES PROCÉDURES
DE CONVERSION.

NUMÉROS DE PIÈCE DES TROUSSES DE CONVERSION :
CRNGELEV001A00 POUR ALTITUDES ENTRE 3 000 ET 10 000 PIEDS
CRNGELEV002A00 POUR ALTITUDES ENTRE 10 000 ET 14 000 PIEDS

PRESSION DE COLLECTEUR: 3,0 DE COLONNE D'EAU ÉTAGE SUPÉRIEUR
2,0 DE COLONNE D'EAU ÉTAGE INFÉRIEUR
PRESSION MINIMUM DE L'ARRIVÉE DE GAZ : 5,0 DE COLONNE D'EAU
PRESSION MAXIMUM DE L'ARRIVÉE DE GAZ : 13,0 DE COLONNE D'EAU

SE RÉFÉRER AU TABLEAU DE COMPENSATION D'ALTITUDE FOURNI AVEC LA TROUSSE POUR
LES INFORMATIONS NÉCESSAIRES À L'ACHEVEMENT DE CETTE SECTION.

ALTITUDE D'INSTALLATION _____ M

TAILLE DE LA BUSE INSTALLÉE _____

CAPACITÉ D'ENTRÉE À L'ALTITUDE D'INSTALLATION _____ BTU/HR

POUR LES INSTALLATIONS AUX CANADA, LA CAPACITÉ D'ENTRÉE DOIT ÊTRE DÉPRÉCIEE
DE 10% POUR LES ALTITUDES SITUÉES ENTRE 2 000 PIEDS (610 MÈTRES) ET 4 500 PIEDS
(1372 MÈTRES) AU DESSUS DU NIVEAU DE LA MER.

50HE501331 2.0

**CONVERSION KIT RATING PLATE
PROPANE GAS**

APPLIES TO MODELS 48TC AND 48HC
REFER TO MAIN RATING PLATE FOR SPECIFIC MODEL NUMBER.
THIS UNIT HAS BEEN CONVERTED TO OPERATE WITH PROPANE GAS
AT ALTITUDES FROM 0 TO 14,000 FEET.
REFER TO KIT INSTRUCTIONS FOR CONVERSION PROCEDURES.

CONVERSION KIT PART NUMBERS:
CRLPKIT9001A00 FOR 0 TO 2,000 FT. ELEVATION
CRLPELEVO05A00 FOR 2,000 TO 10,000 FT. ELEVATION
CRLPELEVO06A00 FOR 10,000 TO 14,000 FT. ELEVATION

MANIFOLD PRESSURE: 10.0 IN. W.C. HIGH STAGE
6.6 IN. W.C. LOW STAGE
MINIMUM GAS SUPPLY PRESSURE: 11.0 IN. W.C.
MAXIMUM GAS SUPPLY PRESSURE: 13.0 IN. W.C.

REFER TO ALTITUDE COMPENSATION TABLES FOUND IN KIT INSTRUCTIONS FOR
REQUIRED INFORMATION TO COMPLETE THIS SECTION.

INSTALLATION ALTITUDE _____ FT

ORIFICE SIZE INSTALLED _____

INPUT RATE AT INSTALLATION ALTITUDE _____ BTU/HR

FOR INSTALLATIONS IN CANADA, THE INPUT RATING SHOULD BE DERATED BY 10%
FOR ALTITUDES FROM 2,000 FT (610 M) TO 4,500 FT (1372 M) ABOVE SEA LEVEL.

**PLAQUE SIGNALÉTIQUE DE TROUSSE DE CONVERSION
GAZ PROPANE**

APPLICABLE AUX MODÈLES 48TC ET 48HC
SE RÉFÉRER À LA PLAQUE SIGNALÉTIQUE PRINCIPALE POUR LE NUMÉRO DE MODÈLE SPÉCIFIQUE
CET APPAREIL A FAIT L'OBJET D'UNE CONVERSION POUR UN FONCTIONNEMENT AU GAZ PROPANE
À DES ALTITUDES SITUÉES ENTRE 0 ET 14 000 PIEDS.
SE RÉFÉRER AUX INSTRUCTIONS FOURNIES AVEC LA TROUSSE POUR OBTENIR LES PROCÉDURES
DE CONVERSION.

NUMÉROS DE PIÈCE DES TROUSSES DE CONVERSION :
CRLPKIT9001A00 POUR ALTITUDES ENTRE 0 ET 2 000 PIEDS
CRLPELEVO05A00 POUR ALTITUDES ENTRE 2 000 ET 10 000 PIEDS
CRLPELEVO06A00 POUR ALTITUDES ENTRE 10 000 ET 14 000 PIEDS

PRESSION DE COLLECTEUR: 10,0 DE COLONNE D'EAU ÉTAGE SUPÉRIEUR
6,6 DE COLONNE D'EAU ÉTAGE INFÉRIEUR
PRESSION MINIMUM DE L'ARRIVÉE DE GAZ : 11,0 DE COLONNE D'EAU
PRESSION MAXIMUM DE L'ARRIVÉE DE GAZ : 13,0 DE COLONNE D'EAU

SE RÉFÉRER AU TABLEAU DE COMPENSATION D'ALTITUDE FOURNI AVEC LA TROUSSE POUR
LES INFORMATIONS NÉCESSAIRES À L'ACHEVEMENT DE CETTE SECTION.

ALTITUDE D'INSTALLATION _____ M

TAILLE DE LA BUSE INSTALLÉE _____

CAPACITÉ D'ENTRÉE À L'ALTITUDE D'INSTALLATION _____ BTU/HR

POUR LES INSTALLATIONS AUX CANADA, LA CAPACITÉ D'ENTRÉE DOIT ÊTRE DÉPRÉCIEE
DE 10% POUR LES ALTITUDES SITUÉES ENTRE 2 000 PIEDS (610 MÈTRES) ET 4 500 PIEDS
(1372 MÈTRES) AU DESSUS DU NIVEAU DE LA MER.

50HE501340 2.0

C09399

Fig. 10 - Conversion Kit Rating Plate Label

Table 2 – Altitude Compensation*
48HC 17-28 , 48LC 14-26, 48TC 17-30 ,
580J 17-30, 581J 17-28
RGS 210-336, RGH 181-303

Natural Gas

ELEVATION		NOMINAL HEAT INPUT							
		176k BTUH		220k BTUH		310k BTUH		400k BTUH	
FT	M	Orifice Size	Input (btu/hr)	Orifice Size	Input (btu/hr)	Orifice Size	Input (btu/hr)	Orifice Size	Input (btu/hr)
0 - 2000	610	30	176,000	30	220,000	30	310,000	30	400,000
2000	610	30	161,920	30	202,400	30	285,200	30	368,000
3000	914	31 ¹	154,880	31 ¹	193,600	31 ¹	272,800	31 ¹	352,000
4000	1219	31 ¹	147,840	31 ¹	184,800	31 ¹	260,400	31 ¹	336,000
5000	1524	31 ¹	140,800	31 ¹	176,000	31 ¹	248,000	31 ¹	320,000
6000	1829	31 ¹	133,760	31 ¹	167,200	31 ¹	235,600	31 ¹	304,000
7000	2134	32 ¹	126,720	32 ¹	158,400	32 ¹	223,200	32 ¹	288,000
8000	2438	32 ¹	119,680	32 ¹	149,600	32 ¹	210,800	32 ¹	272,000
9000	2743	34 ¹	112,640	34 ¹	140,800	34 ¹	198,400	34 ¹	256,000
10000	3048	35 ²	105,600	35 ²	132,000	35 ²	186,000	35 ²	240,000
11000	3353	37 ²	98,560	37 ²	123,200	37 ²	173,600	37 ²	224,000
12000	3658	37 ²	91,520	37 ²	114,400	37 ²	161,200	37 ²	208,000
13000	3962	39 ²	84,480	39 ²	105,600	39 ²	148,800	39 ²	192,000
14000	4267	39 ²	77,440	39 ²	96,800	39 ²	136,400	39 ²	176,000

Propane Gas

ELEVATION		NOMINAL HEAT INPUT							
		176k BTUH		220k BTUH		310k BTUH		400k BTUH	
FT	M	Orifice Size	Input (btu/hr)	Orifice Size	Input (btu/hr)	Orifice Size	Input (btu/hr)	Orifice Size	Input (btu/hr)
0 - 2000	610	48 ⁵	176,000	48 ⁵	220,000	48 ⁵	310,000	48 ⁵	400,000
2000	610	49 ³	161,920	49 ³	202,400	49 ³	285,200	49 ³	368,000
3000	914	49 ³	154,880	49 ³	193,600	49 ³	272,800	49 ³	352,000
4000	1219	49 ³	147,840	49 ³	184,800	49 ³	260,400	49 ³	336,000
5000	1524	50 ³	140,800	50 ³	176,000	50 ³	248,000	50 ³	320,000
6000	1829	50 ³	133,760	50 ³	167,200	50 ³	235,600	50 ³	304,000
7000	2134	50 ³	126,720	50 ³	158,400	50 ³	223,200	50 ³	288,000
8000	2438	51 ³	119,680	51 ³	149,600	51 ³	210,800	51 ³	272,000
9000	2743	51 ³	112,640	51 ³	140,800	51 ³	198,400	51 ³	256,000
10000	3048	52 ⁴	105,600	52 ⁴	132,000	52 ⁴	186,000	52 ⁴	240,000
11000	3353	52 ⁴	98,560	52 ⁴	123,200	52 ⁴	173,600	52 ⁴	224,000
12000	3658	53 ⁴	91,520	53 ⁴	114,400	53 ⁴	161,200	53 ⁴	208,000
13000	3962	53 ⁴	84,480	53 ⁴	105,600	53 ⁴	148,800	53 ⁴	192,000
14000	4267	53 ⁴	77,440	53 ⁴	96,800	53 ⁴	136,400	53 ⁴	176,000

* As the height above sea level increases, there is less oxygen per cubic ft. of air. Therefore, heat input rate should be reduced at higher altitudes.

KIT NO

- xx¹ = CRNGELEV001A00
- xx² = CRNGELEV002A00
- xx³ = CRNGELEV005A00
- xx⁴ = CRNGELEV006A00
- xx⁵ = CRLPKIT9001A00