

SERVICE MANUAL

Residential Small Package Products

Air Conditioners and Heat Pumps Using R-410A Refrigerant

TABLE OF CONTENTS

	PAGE
SAFETY CONSIDERATIONS	2
INTRODUCTION	2
INSTALLATION GUIDELINE	2
ACCESSORY DESCRIPTIONS	2
LOW-AMBIENT COOLING GUIDELINE	3
CABINET ASSEMBLY & COMPONENTS	3
ELECTRICAL	9-10
Aluminum Wire	9
Contactor	9
Capacitor	9
Cycle Protector	10
Crankcase Heater	10
PRESSURE SWITCHES	10-11
Low-Pressure Switch	10
High-Pressure Switch (AC & HP)	10
Loss Of Charge Switch (HP only)	11
DEFROST THERMOSTAT	11
DEFROST CONTROL BOARD	11-11
Defrost Control	11
COPELAND SCROLL, DANFOSS SCROLL , LG SCROLL	14-15
Compressor Failures	15
Mechanical Failures	15
Electrical Failures	15
RECIPROCATING COMPRESSOR	16-19
Mechanical Failures	16
Electrical Failures	17
FAN MOTOR	19
COMPRESSOR PLUG	19
LOW-VOLTAGE TERMINALS	20
REFRIGERATION SYSTEM	20-23
Refrigerant	20
Compressor Oil	20
Brazing	20
Liquid Line Filter Drier	22
Suction Line Filter Drier	22
Accumulator	22
Thermostatic Expansion Valve (TXV)	23
PISTON BODY CLEANING OR REPLACEMENT	24
REFRIGERATION SYSTEM REPAIR	24
Leak Detection	24

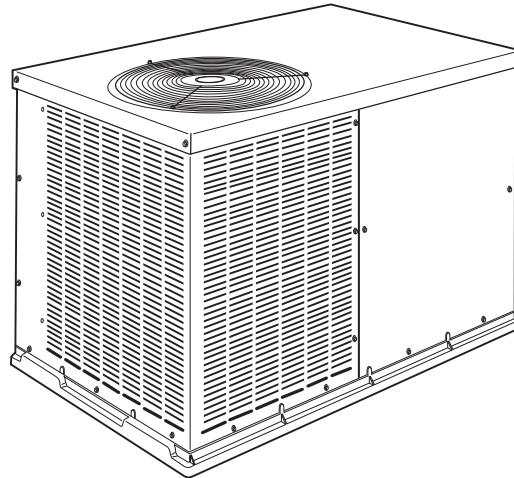

**24-48 A/C and Heat Pump
60 A/C & 13 SEER Heat Pump**

A10165

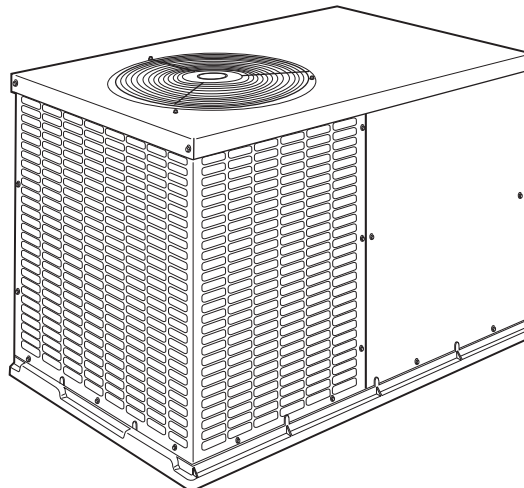

60 14 SEER Heat Pump

A150067

Figure 1 – A/C and Heat Pump

	PAGE
Coil Removal	25
Compressor Removal and Replacement	25
System Clean-Up After Burnout	26
Evacuation	26
CHECK CHARGE	27
TROUBLESHOOTING WITH SUPERHEAT	27
INDOOR AIRFLOW AND AIRFLOW ADJUSTMENTS	28-31
Refrigerant	28
Heating Check Charge Procedure	29

Sequence of Operation 31
 ECM FAN MOTOR TROUBLESHOOTING 31–32
 Time Delays 31
 Pressure Switches 32
 Accumulator, Reversing Valve (RVS) 32
 Control Box 32
 CARE AND MAINTENANCE 37
 R-410A QUICK REFERENCE GUIDE 38
 INDEX OF TABLES 42

SAFETY CONSIDERATIONS

Installation, service, and repair of these units should be attempted only by trained service technicians familiar with standard service instruction and training material.

All equipment should be installed in accordance with accepted practices and unit Installation Instructions, and in compliance with all national and local codes. Power should be turned off when servicing or repairing electrical components. Extreme caution should be observed when troubleshooting electrical components with power on. Observe all warning notices posted on equipment and in instructions or manuals.

⚠ WARNING

UNIT OPERATION AND SAFETY HAZARD

Failure to follow this warning could result in personal injury or equipment damage.

R-410A systems operate at higher pressures than standard R-22 systems. Do not use R-22 service equipment or components on these R-410A units. Ensure service equipment is rated for R-410A.

Refrigeration systems contain refrigerant under pressure. Extreme caution should be observed when handling refrigerants. Wear safety glasses and gloves to prevent personal injury. During normal system operations, some components are hot and can cause burns. Rotating fan blades can cause personal injury. Appropriate safety considerations are posted throughout this manual where potentially dangerous techniques are addressed.

Follow all safety codes. Wear safety glasses, protective clothing, and work gloves. Have a fire extinguisher available. Read these instructions thoroughly and follow all warnings or cautions included in literature and attached to the unit. Consult local building codes, the current editions of the National Electrical Code (NEC) NFPA 70 and NFPA 90B–Installation Warm Air Heating and A/C Systems (Residential).

In Canada refer to the current editions of the Canadian Electrical Code CSA C22.1.

INTRODUCTION

This document provides required system information necessary to install, service, repair or maintain the small package products (SPP) air conditioners and heat pumps using R-410A refrigerant.

Refer to the unit Product Data/Technical specifications for rating information, electrical data, required clearances, additional component part numbers and related pre-sale data. Installation Instructions are also available per specific models.

Information in this document refers to units produced in 2010 to current.

INSTALLATION GUIDELINE

Residential New Construction

Specifications for these units in the residential new construction market require the unit to be installed outdoors and meet all local code and requirements. Consult the Installation Instructions for any additional installation detail.

Add-On Replacement (Retrofit)

Specifications for these units in the add-on replacement/retrofit market require the unit to be installed outdoors and meet all local codes and requirements. Clearances, power supply, system static needs to be check to ensure that the replacement unit can perform within the design parameter desired specified in the Product Data.

ACCESSORIES

Table 1 – Required Field-Installed Accessories for Air Conditioners and Heat Pumps

Accessory	Required for low ambient cooling applications (Below 40°F / 4.4°C)	Accessory Part Number
Motormaster II Low Ambient Kit	Yes	CPLOWAMB001A00
Evaporator Freeze Thermostat	Recommended	NASA00201FS
Compressor Start Assist (CTCR)	Yes	CPHSTART002A00
Isolation Relay (Required for Heat Pumps)	Yes	1184479
Crankcase Heater	--	See below...
-- AC 13 SEER 24–42	Yes	CPCRKHTR007A00
-- AC 14 SEER 24–36		
-- AC 13 SEER 48–60	Yes	CPCRKHTR004A00
-- AC 14 SEER 42–60		
-- HP 13 SEER 42–60		
-- HP 14 SEER 42–60		
-- HP 13 SEER 24–36	Yes	CPCRKHTR008A00
-- HP 14 SEER 24–36		

ACCESSORY DESCRIPTIONS

Refer to Table 1 for an Accessory Usage Guide for Air Conditioners and Heat Pumps. Refer to the appropriate section below for a description of each accessory and its use.

1. Crankcase Heater

An electric resistance heater which mounts to the base of the compressor to keep the lubricant warm during off cycles. Improves compressor lubrication on restart and minimizes the chance of liquid slugging.

Usage Guideline:

Required in low ambient cooling applications.

Suggested in all commercial applications.

2. Evaporator Freeze Thermostat

An SPST temperature-actuated switch that stops unit operation when evaporator reaches freeze-up conditions.

Usage Guideline:

Required when low ambient kit has been added.

3. Isolation Relay

An SPDT relay which switches the low-ambient controller out of the outdoor fan motor circuit when the heat pump switches to heating mode.

Usage Guideline:

Required in all heat pumps where low ambient kit has been added

4. Outdoor Thermostat Kit

Locks out the accessory electric heater until outdoor ambient conditions falls below the pre-set temperature. This kit will activate the electric heat when additional heat is required at lower ambient making it a more efficient system.

LOW-AMBIENT COOLING GUIDELINE

The minimum operating temperature for these units in cooling mode is 40°F/4.4°C outdoor ambient without additional accessories. This equipment may be operated in cooling mode at ambient temperatures below 40°F/4.4°C when the accessories listed in Table 1 are installed.

CABINET ASSEMBLY

Basic Cabinet Designs

Certain maintenance routines and repairs require removal of the cabinet panels. There are 3 cabinet sizes for the air conditioning and heat pump models. However, all of the units have similar panel construction other than their size. The base footprint is the same on all three cabinet sizes.

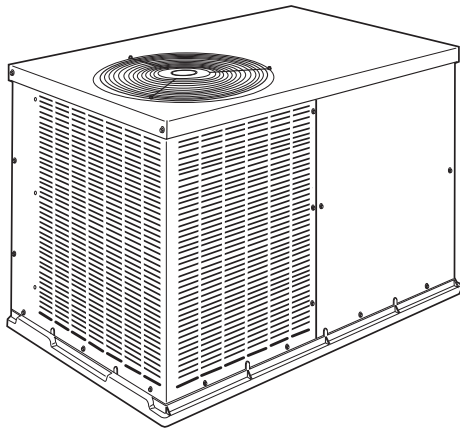

Small, Medium and Large Cabinet

A10165

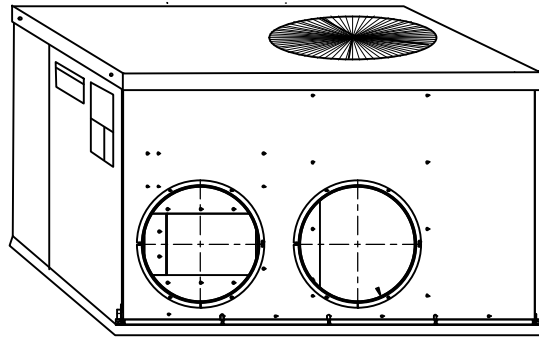

REAR VIEW

Small and Medium Cabinet

A10166

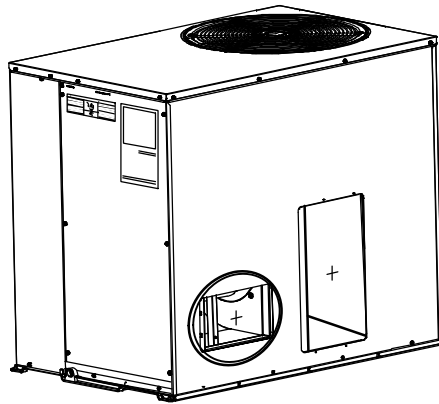

Medium and Large Cabinet Rear View

A10167

Figure 2 – Cabinet Designs

Air Conditioners - 13 SEER

UNIT	ELECTRICAL CHARACTERISTICS			UNIT WT.			UNIT HEIGHT			CENTER OF GRAVITY IN (MM)		
	LSB.	KG.	W.	LSB.	KG.	W.	A	Y	Z	X	Y	Z
42	208/230-1-60	158	138	34-1/8 (867)	19 (483)	14 (356)	19 (483)	19 (483)	16 (406)	14 (356)	19 (483)	16 (406)
48	208/230-1-60	158	138	34-1/8 (867)	19 (483)	14 (356)	19 (483)	19 (483)	16 (406)	14 (356)	19 (483)	16 (406)
60	208/230-1-60	158	138	34-1/8 (867)	19 (483)	14 (356)	19 (483)	19 (483)	16 (406)	14 (356)	19 (483)	16 (406)

Heat Pump - 13 SEER

UNIT	ELECTRICAL CHARACTERISTICS			UNIT WT.			UNIT HEIGHT			CENTER OF GRAVITY IN (MM)		
	LSB.	KG.	W.	LSB.	KG.	W.	A	Y	Z	X	Y	Z
42	208/230-1-60	154	134	42-1/8 (1070)	19 (483)	14 (356)	19 (483)	19 (483)	19 (483)	14 (356)	19 (483)	19 (483)
48	208/230-1-60	154	134	42-1/8 (1070)	19 (483)	14 (356)	19 (483)	19 (483)	19 (483)	14 (356)	19 (483)	19 (483)
60	208/230-1-60	154	134	42-1/8 (1070)	19 (483)	14 (356)	19 (483)	19 (483)	19 (483)	14 (356)	19 (483)	19 (483)

Air Conditioners - 14 SEER

UNIT	ELECTRICAL CHARACTERISTICS			UNIT WT.			UNIT HEIGHT			CENTER OF GRAVITY IN (MM)		
	LSB.	KG.	W.	LSB.	KG.	W.	A	Y	Z	X	Y	Z
42	208/230-1-60	158	138	34-1/8 (867)	19 (483)	14 (356)	19 (483)	19 (483)	16 (406)	14 (356)	19 (483)	16 (406)
48	208/230-1-60	158	138	34-1/8 (867)	19 (483)	14 (356)	19 (483)	19 (483)	16 (406)	14 (356)	19 (483)	16 (406)
60	208/230-1-60	158	138	34-1/8 (867)	19 (483)	14 (356)	19 (483)	19 (483)	16 (406)	14 (356)	19 (483)	16 (406)

Heat Pump - 14 SEER

UNIT	ELECTRICAL CHARACTERISTICS			UNIT WT.			UNIT HEIGHT			CENTER OF GRAVITY IN (MM)		
	LSB.	KG.	W.	LSB.	KG.	W.	A	Y	Z	X	Y	Z
42	208/230-1-60	154	134	42-1/8 (1070)	19 (483)	14 (356)	19 (483)	19 (483)	19 (483)	14 (356)	19 (483)	19 (483)
48	208/230-1-60	154	134	42-1/8 (1070)	19 (483)	14 (356)	19 (483)	19 (483)	19 (483)	14 (356)	19 (483)	19 (483)
60	208/230-1-60	154	134	42-1/8 (1070)	19 (483)	14 (356)	19 (483)	19 (483)	19 (483)	14 (356)	19 (483)	19 (483)

NEC REQUIRED CLEARANCES

BETWEEN UNITS, POWER ENTRY SIDE.....42.0 (1067)
 UNIT AND UNGROUNDED SURFACES, POWER ENTRY SIDE.....36.0 (914)
 GROUNDED SURFACES, POWER ENTRY SIDE.....42.0 (1067)
 SIDE OF UNIT WITH DUCT OPENINGS.....0

REQUIRED CLEARANCE FOR SERVICING

TOP OF UNIT.....36.0 (914)
 SIDE OF UNIT OPPOSITE DUCT OPENINGS.....36.0 (914)
 SIDE OF UNIT WITH DUCT OPENINGS.....30.0 (762)
 (EXCEPT FOR NEC REQUIREMENTS).....30.0 (762)

NOTE: CLEARANCES MUST BE MAINTAINED TO PREVENT RECIRCULATION OF AIR FROM CONDENSATE DRAIN DISCHARGE. A REMOVABLE FENCE OR BARRICADE REQUIRES NO CLEARANCE.

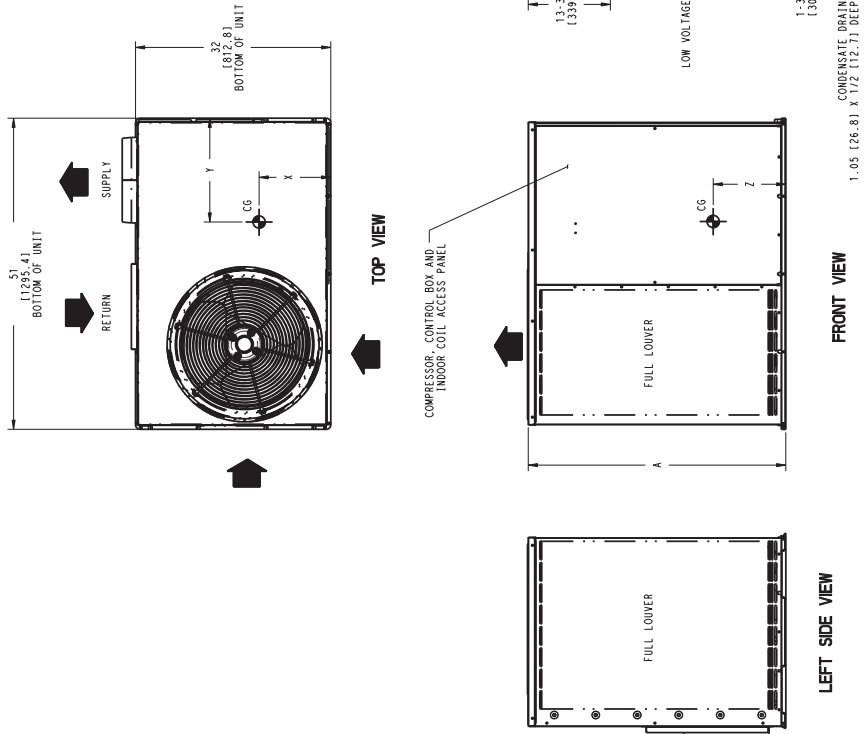

Figure 4 – Unit Base Dimensions (Medium, Large Cabinet except 60 size)

A14537B

A14537B

UNIT	ELECTRICAL CHARACTERISTICS		UNIT WT.		CENTER OF GRAVITY IN [MM]			
	LBS.	KG.	A	X	Y	Z		
60	425	193	42-1/8 [1070]	14 [356]	19 [483]	19-3/4 [503]		

REQUIRED CLEARANCES TO COMBUSTIBLE MATL.

TOP OF UNIT..... 0 INCHES [0MM]
 BOTTOM OF UNIT..... 0 INCHES [0MM]
 SIDE OF UNIT..... 0 INCHES [0MM]
 SIDE OF UNIT OPPOSITE DUCT OPENINGS..... 0 INCHES [0MM]

NEC. REQUIRED CLEARANCES.

BETWEEN UNITS, POWER ENTRY SIDE..... 42.0 [1067] INCHES [MM]
 UNIT AND UNGROUNDED SURFACES, POWER ENTRY SIDE..... 36.0 [914] INCHES [MM]
 UNITS, CONDENSATE DRAIN AND OTHER GROUNDED SURFACES, POWER ENTRY SIDE..... 42.0 [1067] INCHES [MM]

REQUIRED CLEARANCE FOR SERVICING

TOP OF UNIT, OPPOSITE DUCT OPENINGS..... 36.0 [914] INCHES [MM]
 SIDE OF UNIT, OPPOSITE DUCT OPENINGS..... 36.0 [914] INCHES [MM]
 SIDE OF UNIT, POWER ENTRY..... 30.0 [762] INCHES [MM] (EXCEPT FOR NEC REQUIREMENTS)

NOTE: CLEARANCES MUST BE MAINTAINED TO PREVENT RECIRCULATION OF AIR FROM OUTDOOR FAN DISCHARGE... A REMOVABLE FENCE OR BARRICADE REQUIRES NO CLEARANCE.

DIMENSIONS IN [] ARE IN MM

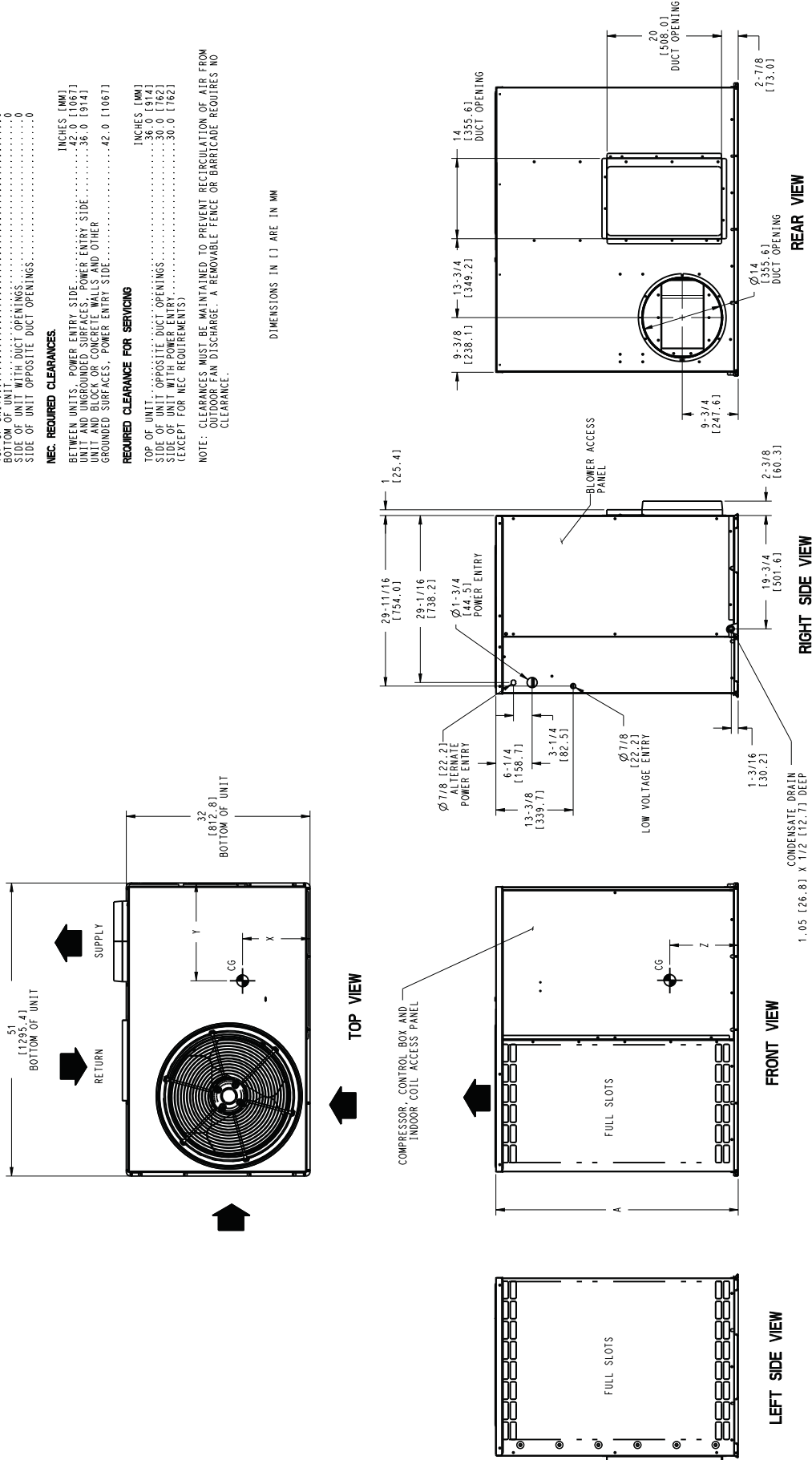

Figure 5 – 14 SEER Heat Pump 60 Size

A150071B

Access Compressor Or Other Internal Cabinet Components

NOTE: Access to most of the components through the side panels of the unit. The top will need to be removed to access the evaporator or condenser coil. In some instances screws on the back of the unit (duct side) will need to be accessed. If the unit is up against the structure, the unit will have to be pulled away for servicing. Follow the procedures below to access the different components:

1. Access to control box, compressor, reversing valve, metering device, accumulator and liquid line drier.
 - a. Removal of the right front panel, opposite the duct flanges will give access to the component above. (See Figure 6.)
2. Access to the indoor fan motor and electric heater
 - a. Removal of the right side (side with electric access), right back panel to access components above. (See Figure 7.)
3. Access or removal of the condenser coil.
 - a. Removal of the top, the control/compressor panel, the front/left side louver panel.
 - b. Screws from the compressor compartment and either the side of the unit or below the condenser fan (depending on the shape of coil) will need to be removed to remove condenser coil. (See Figure 8.)
4. Access or removal of the evaporator coil.
 - a. (24 to 36) The indoor evaporator coil is held in place by screws located in the compressor compartment and behind the return air duct. The 14" return collar must be removed to access these screws.
 - b. (42 to 60) The indoor evaporator coil is held in place by screws located in the compressor compartment and on the rectangular duct flange. The rectangular duct flange does not need to be removed but the left side screws will have to be removed. (See Figure 8 and Figure 9.)

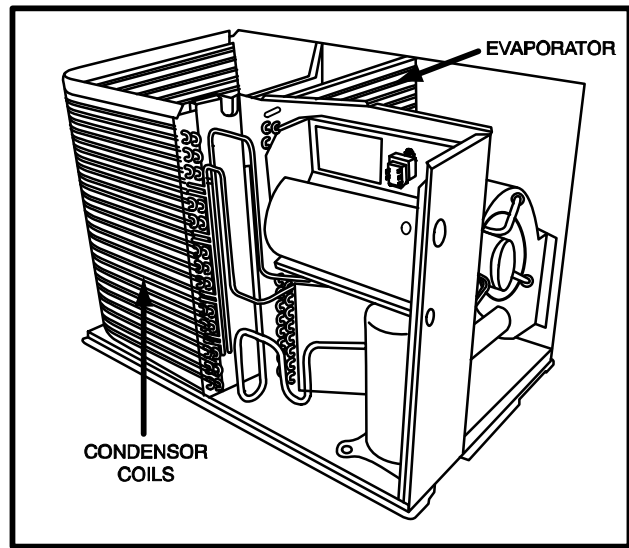

Figure 8 – Access of Condenser Coil

A10161

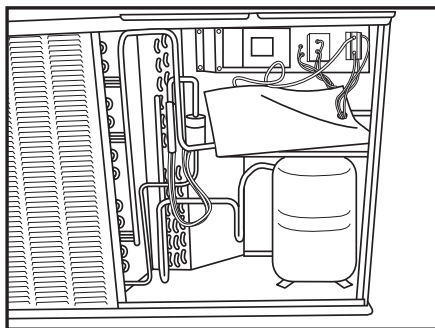

Figure 6 – Removal of Right Front Panel

A10160

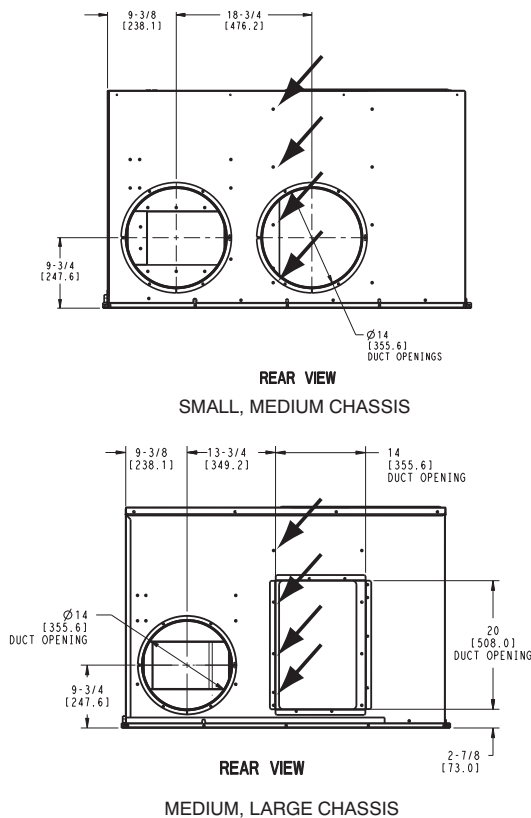

Figure 9 – Location of Screws

A10173

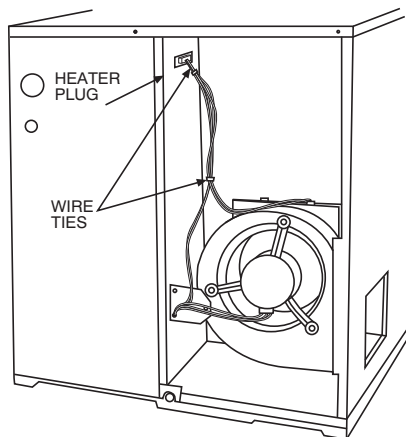

Figure 7 – Removal of Right Side Back Panel

A10159

Labeling

The wiring schematic, sub-cooling charging tables with instructions, and warning labels. Refer to Figure 10 for label location.

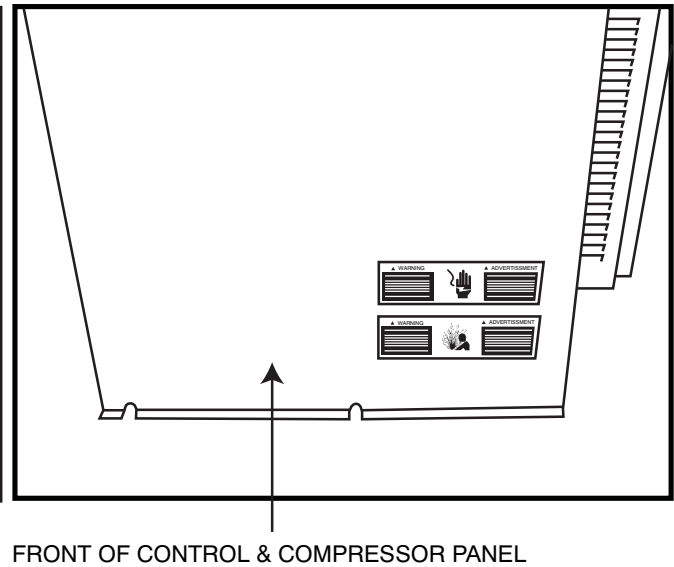
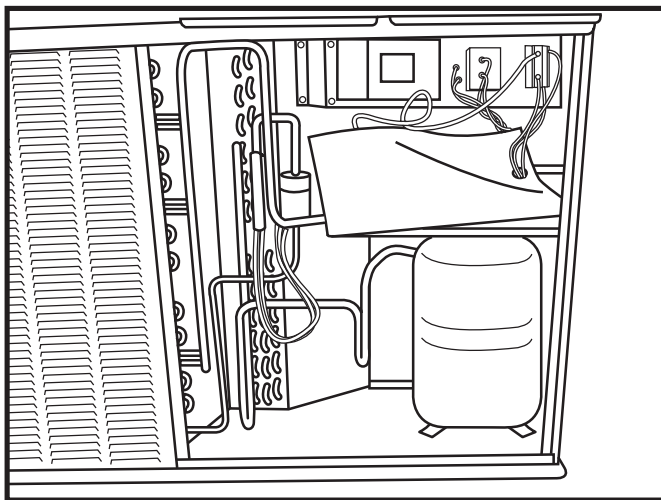
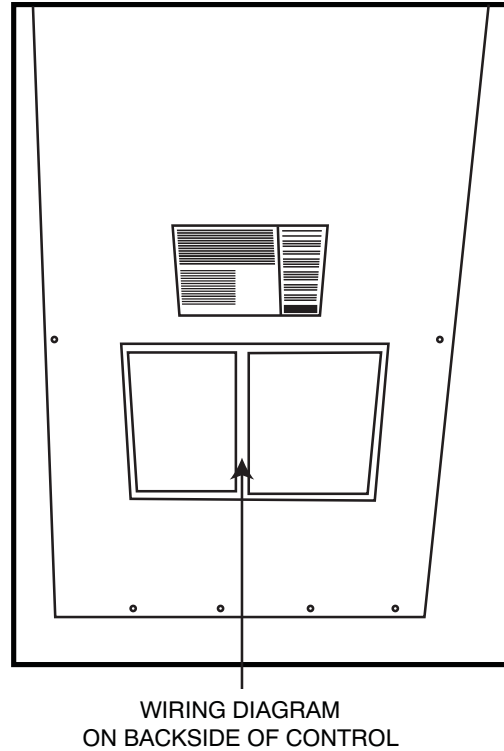
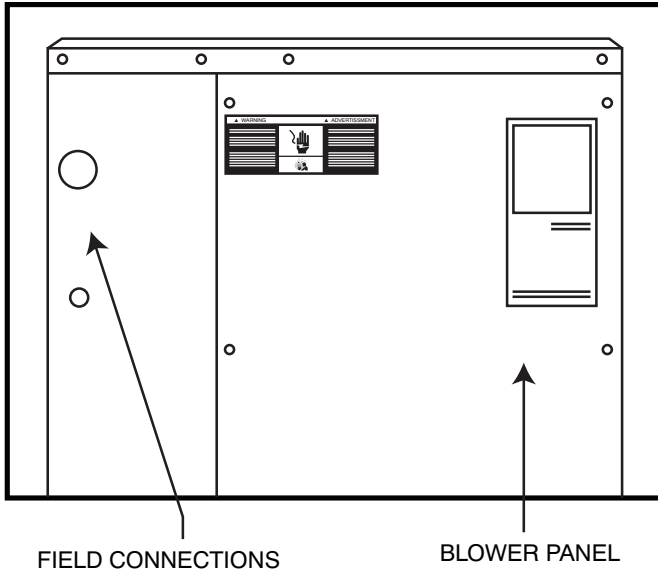

Figure 10 - Label Location

A10163

ELECTRICAL**⚠ WARNING****ELECTRICAL SHOCK HAZARD**

Failure to follow this warning could result in personal injury or death.

Exercise extreme caution when working on any electrical components. Shut off all power to system prior to troubleshooting. Some troubleshooting techniques require power to remain on. In these instances, exercise extreme caution to avoid danger of electrical shock. **ONLY TRAINED SERVICE PERSONNEL SHOULD PERFORM ELECTRICAL TROUBLESHOOTING.**

Aluminum Wire**⚠ CAUTION****UNIT OPERATION AND SAFETY HAZARD**

Failure to follow this caution may result in equipment damage or improper operation.

Aluminum wire may be used in the branch circuit (such as the circuit between the main and unit disconnect), but only copper wire may be used between the unit disconnect and the unit.

Whenever aluminum wire is used in branch circuit wiring with this unit, adhere to the following recommendations.

Connections must be made in accordance with the National Electrical Code (NEC), using connectors approved for aluminum wire. The connectors must be UL approved (marked Al/Cu with the UL symbol) for the application and wire size. The wire size selected must have a current capacity not less than that of the copper wire specified, and must not create a voltage drop between service panel and unit in excess of 2% of unit rated voltage. To prepare wire before installing connector, all aluminum wire must be "brush-scratched" and coated with a corrosion inhibitor such as Pentrox A. When it is suspected that connection will be exposed to moisture, it is very important to cover entire connection completely to prevent an electrochemical action that will cause connection to fail very quickly. Do not reduce effective size of wire, such as cutting off strands so that wire will fit a connector. Proper size connectors should be used. Check all factory and field electrical connections for tightness. This should also be done after unit has reached operating temperatures, especially if aluminum conductors are used.

Contactors

The contactor provides a means of applying power to unit using low voltage (24v) from transformer in order to power contactor coil. Depending on unit model, you may encounter single- or double-pole contactors. Exercise extreme caution when troubleshooting as 1 side of line may be electrically energized. The contactor coil is powered by 24vac. If contactor does not operate:

1. With power off, check whether contacts are free to move. Check for severe burning or arcing on contact points.
2. With power off, use ohmmeter to check for continuity of coil. Disconnect leads before checking. A low

resistance reading is normal. Do not look for a specific value, as different part numbers will have different resistance values.

3. Reconnect leads and apply low-voltage power to contactor coil. This may be done by leaving high-voltage power to outdoor unit off and turning thermostat to cooling. Check voltage at coil with voltmeter. Reading should be between 20v and 30v. Contactor should pull in if voltage is correct and coil is good. If contactor does not pull in, replace contactor.
4. With high-voltage power off and contacts pulled in, check for continuity across contacts with ohmmeter. A very low or 0 resistance should be read. Higher readings could indicate burned or pitted contacts which may cause future failures.

Capacitor**⚠ WARNING****ELECTRICAL SHOCK HAZARD**

Failure to follow this warning could result in personal injury or equipment damage.

Capacitors can store electrical energy when power is off. Electrical shock can result if you touch the capacitor terminals and discharge the stored energy. Exercise extreme caution when working near capacitors. With power off, discharge stored energy by shorting across the capacitor terminals with a 15,000-ohm, 2-watt resistor.

⚠ WARNING**ELECTRICAL SHOCK HAZARD**

Failure to follow this warning could result in personal injury or equipment damage.

Always check capacitors with power off. Attempting to troubleshoot a capacitor with power on can be dangerous. Defective capacitors may explode when power is applied. Insulating fluid inside is combustible and may ignite, causing burns.

Capacitors are used as a phase-shifting device to aid in starting certain single-phase motors. Check capacitors as follows:

1. With power off, discharge capacitors as outlined above. Disconnect capacitor from circuit. Put ohmmeter on R X 10k scale. Using an analog ohmmeter, check each terminal to ground (use capacitor case). Discard any capacitor which measures 1/2 scale deflection or less. Place ohmmeter leads across capacitor and place on R X 10k scale. Meter should jump to a low resistance value and slowly climb to higher value. Failure of meter to do this indicates an open capacitor. If resistance stays at 0 or a low value, capacitor is internally shorted.
2. Capacitance testers are available which will read value of capacitor. If value is not within ± 10 percent value stated on capacitor, it should be replaced. If capacitor is not open or shorted, the capacitance value is calculated by measuring voltage across capacitor and current it draws.

⚠ WARNING

ELECTRICAL SHOCK HAZARD

Failure to follow this warning could result in personal injury or death.
Exercise extreme caution when taking readings while power is on.

Use following formula to calculate capacitance:

Capacitance (mfd) = (2650 X amps)/volts

3. Remove any capacitor that shows signs of bulging, dents, or leaking. Do not apply power to a defective capacitor as it may explode.

Sometimes under adverse conditions, a standard run capacitor in a system is inadequate to start compressor. In these instances, a start assist device is used to provide an extra starting boost to compressor motor. This device is called a positive temperature coefficient (PTCR or PTC) or start thermistor. It is a resistor wired in parallel with the run capacitor. As current flows through the PTC at start-up, it heats up. As PTC heats up, its resistance increases greatly until it effectively lowers the current through itself to an extremely low value. This, in effect, removes the PTC from the circuit.

After system shutdown, resistor cools and resistance value returns to normal until next time system starts. Thermistor device is adequate for most conditions, however, in systems where off cycle is short, device cannot fully cool and becomes less effective as a start device. It is an easy device to troubleshoot. Shut off all power to system.

Check thermistor with ohmmeter as described below. Shut off all power to unit. Remove PTC from unit. Wait at least 10 minutes for PTC to cool to ambient temperature.

Measure resistance of PTC with ohmmeter.

The cold resistance (RT) of any PTC device should be approximately 100–180 percent of device ohm rating.

12.5-ohm PTC = 12.5–22.5 ohm resistance (beige color)

If PTC resistance is appreciably less than rating or more than 200 percent higher than rating, device is defective.

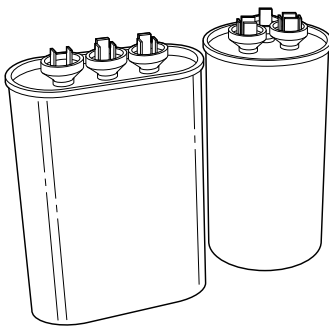

Figure 11 – Capacitors

A94006

Cycle Protector

Corporate thermostats have anti-cycle protection built in to protect the compressor. If cycle protection is needed, consult factory authorized aftermarket offering.

Crankcase Heater

Crankcase heater is a device for keeping compressor oil warm. By keeping oil warm, refrigerant does not migrate to and condense in compressor shell when the compressor is off. This prevents flooded starts which can damage compressor.

On units that have a single-pole contactor, the crankcase heater is wired in parallel with contactor contacts and in series with compressor. (See Figure 12.) When contacts open, a circuit is completed from line side of contactor, through crankcase heater, through run windings of compressor, and to other side of line. When contacts are closed, there is no circuit through crankcase heater because both leads are connected to same side of line. This allows heater to operate when system is not calling for cooling. The heater does not operate when system is calling for cooling.

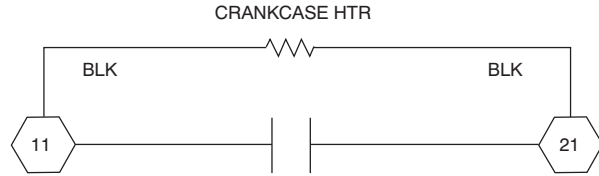

A10174

Figure 12 – Wiring for Single-Pole Contactor

Pressure Switches

Pressure switches are protective devices wired into control circuit (low voltage). They shut off compressor if abnormally high or low pressures are present in the refrigeration circuit. R-410A pressure switches are specifically designed to operate with R-410A systems. R-22 pressure switches must **not** be used as replacements for the R-410A air conditioners or heat pumps. R-410A pressure switches are identified by a pink stripe down each wire.

Low-Pressure Switch

Neither of the air conditioner or heat pump units have a low pressure switch. The heat pump models have a loss of charge switch located downstream of the liquid line filter drier. See loss of charge for more details.

High-Pressure Switch (AC & HP)

The high-pressure switch is located in the discharge line and protects against excessive condenser coil pressure. It opens around 650 psig and closes at 420 (+/- 25) psig for R-410A. High pressure may be caused by a dirty condenser coil, failed fan motor, or condenser air re-circulation.

To check switch:

1. Turn off all power to unit.
2. Disconnect leads on switch.
3. Apply ohmmeter leads across switch. You should have continuity on a good switch.

NOTE: Because these switches are attached to refrigeration system under pressure, it is not advisable to remove this device for troubleshooting unless you are reasonably certain that a problem exists. If switch must be removed, remove and recover all system charge so that pressure gauges read 0 psig. Never open system without breaking vacuum with dry nitrogen.

⚠ CAUTION

PERSONAL INJURY HAZARD

Failure to follow this caution may result in personal injury.

Wear safety glasses, protective clothing, and gloves when handling refrigerant.

To replace switch:

1. Apply heat with torch to solder joint and remove switch.

⚠ CAUTION

PERSONAL INJURY HAZARD

Failure to follow this caution may result in personal injury.

Wear safety glasses when using torch. Have quenching cloth available. Oil vapor in line may ignite when switch is removed.

2. Braze in a new pressure switch.

Loss of Charge Switch (HP Only)

Located on liquid line of heat pump only, the liquid line pressure switch functions similar to conventional low-pressure switch.

Because heat pumps experience very low suction pressures during normal system operation, a conventional low-pressure switch cannot be installed on suction line. This switch is installed in liquid line instead and acts as loss-of-charge protector. The liquid-line is the low side of the system in heating mode. It operates identically to low-pressure switch except it opens at 20 (+/- 5) psig and closes at 45 (+/- 10) psig for R-410A. Troubleshooting and removing this switch is identical to procedures used on other switches. Observe same safety precautions.

Defrost Thermostats

Defrost thermostat signals heat pump that conditions are right for defrost or that conditions have changed to terminate defrost. It is a thermally actuated switch clamped to outdoor coil to sense its temperature. Normal temperature range is for 13 SEER closed at 32° ± 3°F and open at 65° ± 5°F. For 14 SEER 33° ± 3°F and open at 55° ± 5°F.

Check Defrost Thermostat

There is a liquid header with a brass distributor and feeder tubes going into outdoor coil. At the end of 1 of the feeder tubes, there is a 3/8-in. OD stub tube approximately 3 in. long. (See Figure 13.) The defrost thermostat should be located on stub tube. Note that there is only 1 stub tube used with a liquid header, and on most units it is the bottom circuit. (See Figure 15 and Figure 16 for DFT Sensor Location.)

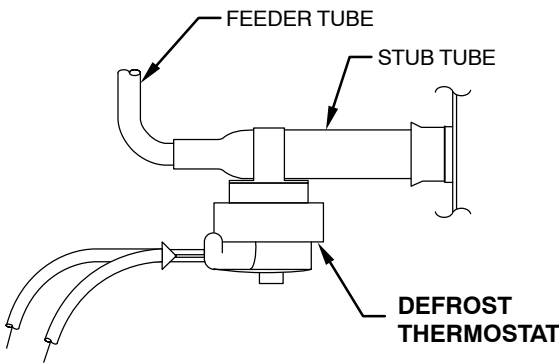

Figure 13 - Defrost Thermostat Location

NOTE: The defrost thermostat must be located on the liquid side of the outdoor coil on the bottom circuit and as close to the coil as possible.

Defrost Control Board

Troubleshooting defrost control involves a series of simple steps that indicate whether or not board is defective.

NOTE: This procedure allows the service technician to check control board and defrost thermostat for defects. First, troubleshoot to make sure unit operates properly in heating

and cooling modes. This ensures operational problems are not attributed to the defrost control board.

Defrost Control

The defrost control is used in all R-410A Mobile Home series heat pump models. Its features include selectable defrost intervals of 30, 60, 90 minutes, and standard defrost speed up capability. This section describes the sequence of operation and trouble shooting methods for this control.

Cooling Sequence of Operation

On a call for cooling, thermostat makes R-O, R-Y, and R-G. Circuit R-O energizes reversing valve switching it to cooling position. Circuit R-Y sends low voltage through the safeties and energizes the contactor, which starts the compressor and energizes the T1 terminal on the circuit board. This will energize the OF2 fan relay which starts the outdoor fan motor.

When the cycle is complete, R-Y is turned off and compressor and outdoor fan should stop. With corporate thermostats, the O terminal remains energized in the cooling mode. If the mode is switched to heat or Off, the valve is de-energized. There is no compressor delay built into this control.

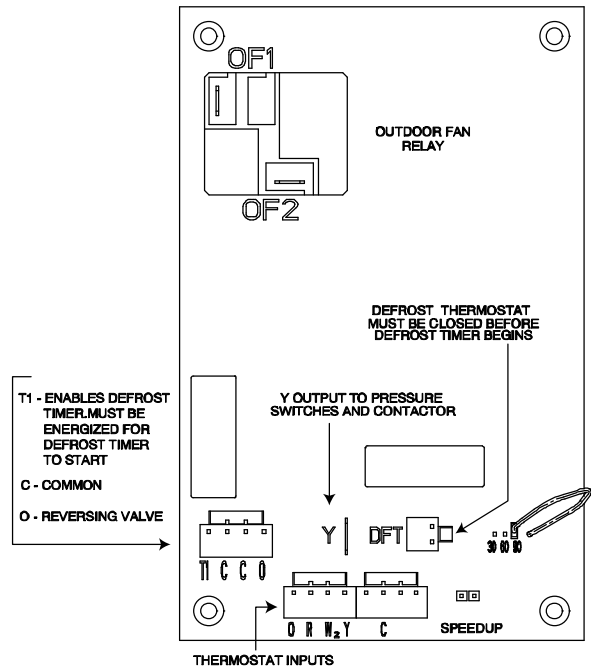

Figure 14 - Defrost Control

A05332

Heating Sequence of Operation

On a call for heating, thermostat makes R-Y, and R-G. Circuit R-Y sends low voltage through the safeties and energizes the contactor, which starts the compressor and energizes the T1 terminal on the circuit board. The T1 terminal energizes the defrost logic. This will energize the OF2 fan relay start the outdoor motor. The T1 terminal must be energized for defrost to function.

When the cycle is complete, R-Y is turned off and the compressor and outdoor fan should stop. There is no compressor delay built into this control.

Defrost Sequence

The defrost control is a time/temperature control that has field selectable settings of 30, 60, and 90 minutes. These represent the amount of time that must pass after closure of the defrost thermostat before the defrost sequence begins.

The defrost thermostat senses coil temperature throughout the heating cycle. When the coil temperature reaches the defrost thermostat setting, it will close, which energizes the DFT terminal and begins the defrost timing sequence. When the DTF has been energized for the selected time, the defrost cycle begins, and the control shifts the reversing valve into cooling position, and turns the outdoor fan off. This shifts hot gas flow into the outdoor coil which melts the frost from the coil. The defrost cycle is terminated when defrost thermostat opens, or automatically after 10 minutes.

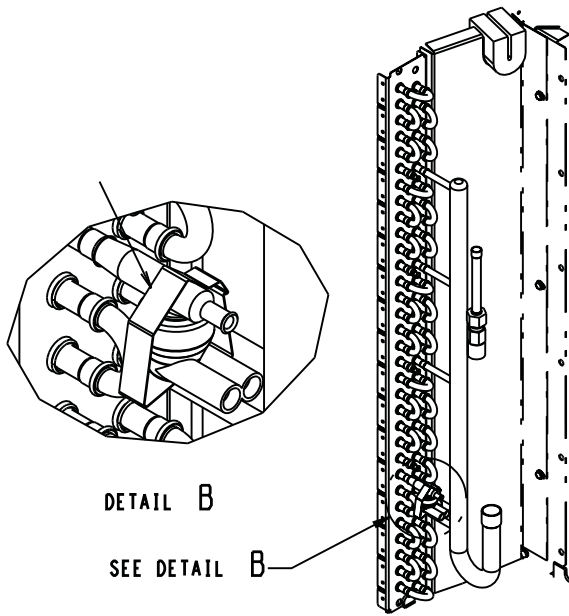

**024, 030 13 SEER
024 14 SEER**

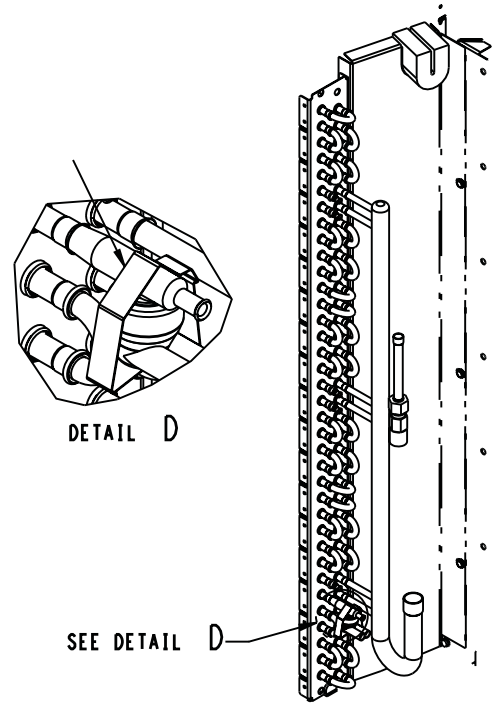

**036 13 SEER
030, 036 14 SEER**

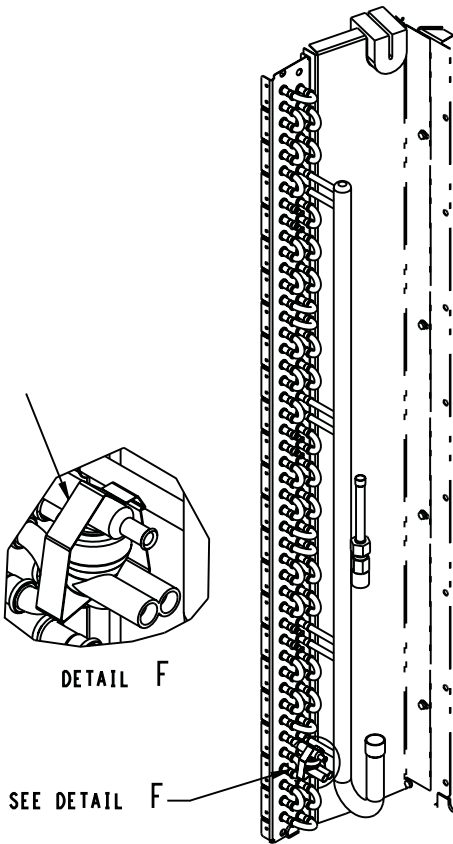

042 13 & 14 SEER

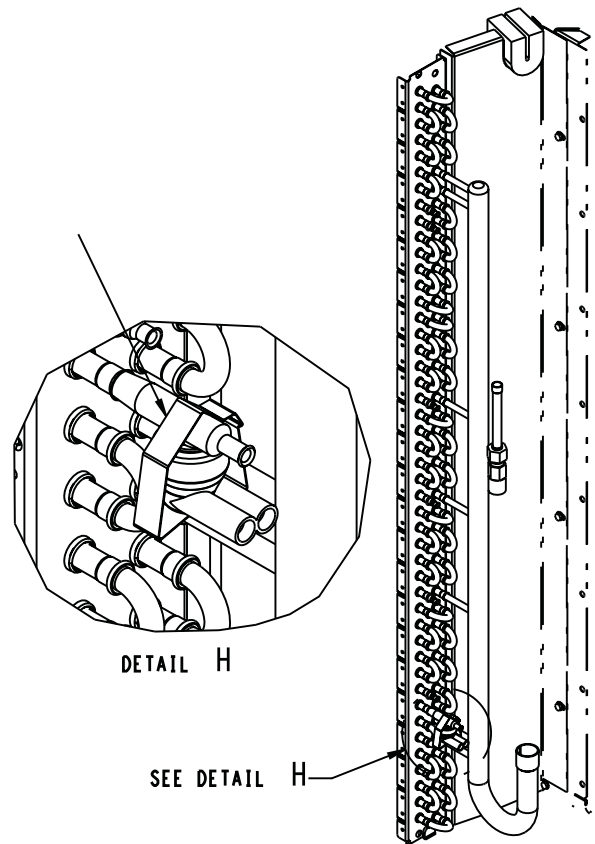

048 13 & 14 SEER

Defrost thermostat can either be located on the bottom of tube (as shown) or on the top and must not interfere with any other tubing.

Figure 15 – DFT Sensor Location 24–48

A14538

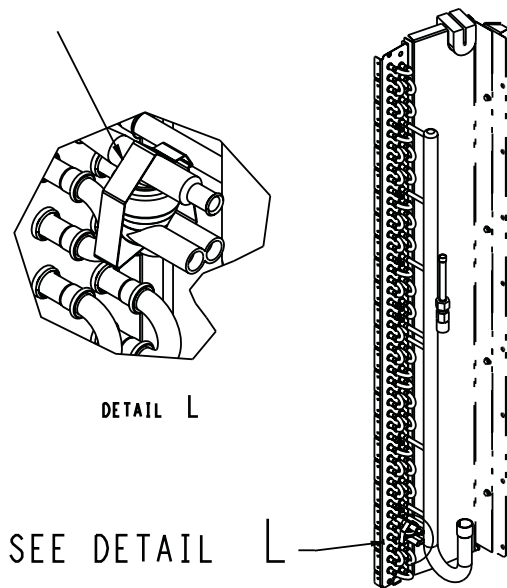
**060 13 SEER**

Defrost thermostat can either be located on the bottom of tube (as shown) or on the top and must not interfere with any other tubing.

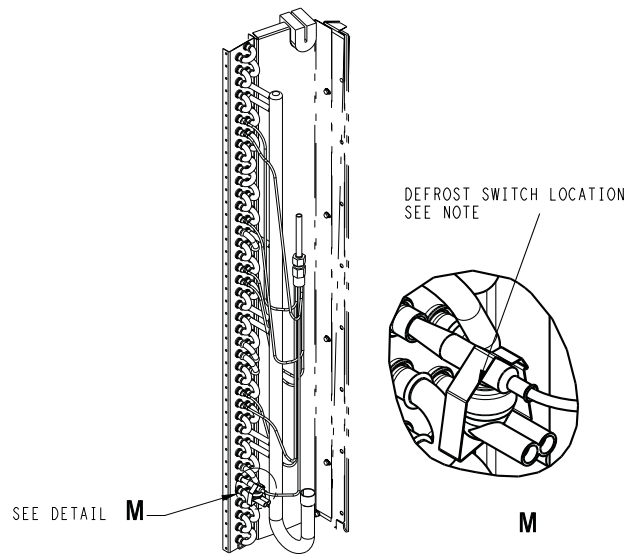

2. Defrost switch can either be located on the bottom of tube (as shown) or on the top and must not interfere with any other tubing.

060 14 SEER Heat Pump

A150080

A150079

Figure 16 – DFT Sensor Location 60**Troubleshooting****If unit will not run:**

1. Does the Y input has 24 volts from thermostat? If not, check thermostat or wire. If yes proceed to #2
2. The Y spade terminal on the circuit board should have 24 volts if Y input is energized. This output goes through the pressure switches and to the contactor. If 24 volts is present on the Y spade terminal, and the contactor is not closed, check voltage on contactor coil. If no voltage is present, check for opened pressure switch.
3. If voltage is present and contactor is open, contactor may be defective. Replace contactor if necessary.
4. If contactor is closed and unit will still not run, check wiring, capacitor and compressor.

Defrost Speedup

To test the defrost function on these units, speed up pins are provided on the circuit board. To force a defrost cycle, the defrost thermostat must be closed, or the defrost thermostat pins must be jumpered. Follow the steps below to force a defrost cycle:

1. Jumper the DFT input .
2. Short the speed up pins. This speeds up the defrost timer by a factor of 256. The longer the defrost interval setting, the longer the pins must be shorted to speed through the timing. For example, if interval is 90 min, the speed up will take $(90/256)\text{min} \times (60\text{seconds} / \text{minute}) = 21 \text{ seconds max}$. This could be shorter depending on how much time has elapsed since the defrost thermostat closed.
3. Remove the short immediately when the unit shifts into defrost. Failure to remove the short immediately will result in a very short forced defrost cycle (the 10 minute timer will be sped through in 2 seconds).
4. When defrost begins, it will continue until the defrost thermostat opens or 10 minutes has elapsed.

NOTE: The T1 terminal on the defrost board powers the defrost timing function. This terminal must be energized before any defrost function will occur.

If defrost thermostat is stuck closed:

Whether the unit is in heating or cooling mode, it will run a defrost cycle for 10 minutes each time the compressor has been energized for the selected time interval. The board will terminate automatically after 10 minutes of defrost time regardless of defrost thermostat position.

If defrost thermostat is stuck open:

The unit will not defrost

If unit will not defrost:

1. Perform the speedup function as described above to test the defrost function of the circuit board.
2. If the unit does not go into defrost after performing the speed up, check for 24 volts on the T1 terminal. This terminal powers the defrost circuit, and must be energized before any defrost function can occur. The T1 should be energized once the Y terminal is energized and the pressure switches are closed. Ensure the T1 wire is connected at the contactor, and that 24 volts is present on the T1 terminal.
3. If all voltages are present and unit will still not run defrost, remove thermostat pigtail harness from board and perform checks directly on input pins with jumper wires. The pigtail may have a bad connection or be mis-wired.

To fully troubleshoot defrost thermostat and control function :

1. Turn thermostat to OFF. Shut off all power to outdoor unit.
2. Remove control box cover for access to electrical components and defrost control board.
3. Disconnect defrost thermostat leads from control board, and connect to ohmmeter. Thermostat leads are black, insulated wires connected to DFT and R terminals on control board. Resistance reading may be zero (indicating closed defrost thermostat), or

- infinity (∞ for open thermostat) depending on outdoor temperature.
- 4. Jumper between DFT and R terminals on control board as shown in Figure 14.
- 5. Disconnect outdoor fan motor lead from OF2. Tape lead to prevent grounding.
- 6. Turn on power to outdoor unit.
- 7. Restart unit in heating mode, allowing frost to accumulate on outdoor coil.
- 8. After a few minutes in heating mode, liquid line temperature at defrost thermostat should drop below closing set point of defrost thermostat of approximately 32°F (0°C). Check resistance across defrost thermostat leads using ohmmeter. Resistance of zero indicates defrost thermostat is closed and operating properly.
- 9. Short between the speed-up terminals using a thermostat screwdriver. This reduces the timing sequence to 1/256 of original time. (See Table 2.)

Table 2 – Defrost Control Speed-Up Timing Sequence

PARAMETER	MINIMUM (MINUTES)	MAXIMUM (MINUTES)	SPEED-UP (NOMINAL)
30-minute cycle	27	33	7 sec
50-minute cycle	45	55	12 sec
90-minute cycle	81	99	21 sec
10-minute cycle	9	11	2 sec

⚠ CAUTION

UNIT DAMAGE HAZARD

Failure to follow this caution may result in equipment damage or improper operation.

Exercise extreme caution when shorting speed-up pins. If pins are accidentally shorted to other terminals, damage to the control board will occur.

- 10. Unit is now operating in defrost mode. Check between C and W2 using voltmeter. Reading on voltmeter should indicate 24v. This step ensures defrost relay contacts have closed, energizing supplemental heat (W2) and reversing valve solenoid (O).
- 11. Unit should remain in defrost no longer than 10 minutes. Actual time in defrost depends on how quickly speed-up jumper is removed. If it takes 2 sec to remove speed-up jumper after unit has switched to defrost, the unit will switch back to heat mode.
- 12. After a few minutes, in defrost (cooling) operation, liquid line should be warm enough to have caused defrost thermostat contacts to open. Check resistance across defrost thermostat. Ohmmeter should read infinite resistance, indicating defrost thermostat has opened at approximately 65°F.
- 13. Shut off unit power and reconnect fan lead.
- 14. Remove jumper between DFT and R terminals. Reconnect defrost thermostat leads. Failure to remove jumper causes unit to switch to defrost every 30, 60, or 90 minutes and remain in defrost for full 10 minutes.
- 15. Replace access panel. Restore power to unit.

If defrost thermostat does not check out following above items or incorrect calibration is suspected, check for defective thermostat as follows:

- 1. Follow items 1–5 above.
- 2. Route sensor or probe using thermocouple temperature measuring device. Attach to liquid line near defrost thermostat. Insulate for more accurate reading.
- 3. Turn on power to outdoor unit.
- 4. Restart unit in heating.
- 5. Within a few minutes, liquid line temperature drops within a range causing defrost thermostat contacts to close. Temperature range is from 36°F (2.2°C) to 29°F (-1.7°C). Notice temperature at which ohmmeter reading goes from ∞ to zero ohms. Thermostat contacts close at this point.
- 6. Short between the speed-up terminals using a small slotted screwdriver.
- 7. Unit changes over to defrost within 21 sec (depending on timing cycle setting). Liquid line temperature rises to range where defrost thermostat contacts open. Temperature range is from 50°F (10°C) to 70°F (21.1°C). Resistance goes from zero to ∞ when contacts are open.
- 8. If either opening or closing temperature does not fall within above ranges or thermostat sticks in 1 position, replace thermostat to ensure proper defrost operation.

NOTE: With timing cycle set at 90 minutes, unit initiates defrost within approximately 21 sec. When you hear the reversing valve changing position, remove screwdriver immediately. Otherwise, control will terminate normal 10-minute defrost cycle in approximately 2 sec.

COPELAND/DANFOSS/LG SCROLL COMPRESSOR

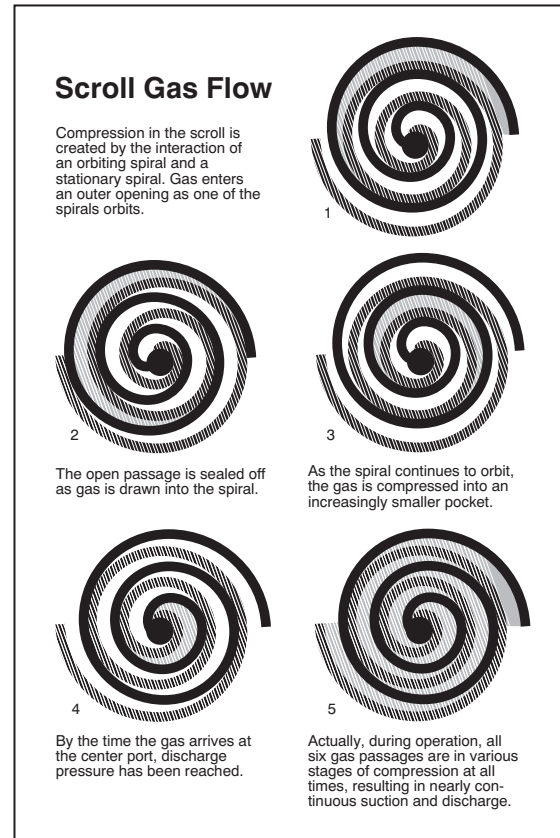

Figure 17 – Scroll Compressor Refrigerant Flow

A90198

The compressors used in these products are specifically designed to operate with designated refrigerant and cannot be interchanged. The compressor is an electrical (as well as mechanical) device. Exercise extreme caution when working near compressors. Power should be shut off, if possible, for most troubleshooting techniques. Refrigerants present additional safety hazards.

⚠ CAUTION

PERSONAL INJURY HAZARD

Failure to follow this caution may result in personal injury.

Wear safety glasses, protective clothing, and gloves when handling refrigerant.

The scroll compressor pumps refrigerant through the system by the interaction of a stationary and an orbiting scroll. (See Figure 17.) The scroll compressor has no dynamic suction or discharge valves, and it is more tolerant of stresses caused by debris, liquid slugging, and flooded starts. The compressor is equipped with an internal pressure relief port. The pressure relief port is a safety device, designed to protect against extreme high pressure. The relief port has an operating range between 550 to 625 psig differential pressure (Copeland) and 550 to 650 psig differential pressure (Danfoss) for R-410A refrigerant. Scrolls have a variety of shut down solutions, depending on model, to prevent backward rotation and eliminate the need for cycle protection.

Compressor Failures

Compressor failures are classified in 2 broad failure categories; mechanical and electrical. Both types are discussed below.

Mechanical Failures

A compressor is a mechanical pump driven by an electric motor contained in a welded or hermetic shell. In a mechanical failure, motor or electrical circuit appears normal, but compressor does not function normally.

⚠ WARNING

ELECTRICAL SHOCK HAZARD

Failure to follow this warning could result in personal injury or death.

Do not supply power to unit with compressor terminal box cover removed.

⚠ WARNING

ELECTRICAL SHOCK HAZARD

Failure to follow this warning could result in personal injury or death.

Exercise extreme caution when reading compressor currents when high-voltage power is on. Correct any of the problems described below before installing and running a replacement compressor.

Locked Rotor

In this type of failure, compressor motor and all starting components are normal. When compressor attempts to

start, it draws locked rotor current and cycles off on internal protection. Locked rotor current is measured by applying a clamp-on ammeter around common (blk) lead of compressor. Current drawn when it attempts to start is then measured. Locked rotor amp (LRA) value is stamped on compressor nameplate.

If compressor draws locked rotor amps and all other external sources of problems have been eliminated, compressor must be replaced. Because compressor is a sealed unit, it is impossible to determine exact mechanical failure. However, complete system should be checked for abnormalities such as incorrect refrigerant charge, restrictions, insufficient airflow across indoor or outdoor coil, etc., which could be contributing to the failure.

Runs, Does Not Pump

In this type of failure, compressor motor runs and turns compressor, but compressor does not pump refrigerant. A clamp-on ammeter on common leg shows a very low current draw, much lower than rated load amp (RLA) value stamped on compressor nameplate. Because no refrigerant is being pumped, there is no return gas to cool compressor motor. It eventually overheats and shuts off on its internal protection.

Noisy Compressor

Noise may be caused by a variety of internal and external factors. Careful attention to the "type" of noise may help identify the source. The following are some examples of abnormal conditions that may create objectionable noise:

1. A gurgling sound may indicate a liquid refrigerant floodback during operation. This could be confirmed if there is no compressor superheat. A compressor superheat of "0" degrees would indicate liquid refrigerant returning to the compressor. Most common reasons for floodback are: loss of evaporator blower, dirty coils, and improper airflow.
2. A rattling noise may indicate loose hardware. Inspect all unit hardware including the compressor grommets.
3. An internal "thunking", "thumping", "grinding" or "rattling" noise could indicate compressor internal failures and may be verified by comparing the compressor amperage to what the compressor should be drawing according to a manufacturer's performance data.
4. A whistling or squealing noise during operation may indicate a partial blockage of the refrigerant charge.
5. A whistle on shut down could indicate a partial leak path as refrigerant is equalizing from high to low side. On occasion, an in-line discharge check valve has prevented this sound.
6. If a compressor hums but won't start it could indicate either a voltage or amperage issue. Verify adequate voltage and operational start components if installed. If it is drawing excessive amperage and voltage doesn't appear to be the problem it may be assumed a locked condition. Ensure refrigerant has had ample time to equalize and boil out of the compressor before condemning.
7. When a heat pump switches into and out of defrost, a "swooshing" noise is expected due to the rapid pressure change within the system. Check that the defrost thermostat or thermistor is operating properly. Insulating the defrost sensing device may also help.

Electrical Failures

The compressor mechanical pump is driven by an electric motor within its hermetic shell. In electrical failures, compressor does not run although external electrical and

mechanical systems appear normal. Compressor must be checked electrically for abnormalities.

Before troubleshooting compressor motor, review this description of compressor motor terminal identification.

Single-Phase Motors

To identify terminals C, S, and R:

1. Turn off all unit power.
2. Discharge run and start capacitors to prevent shock.
3. Remove all wires from motor terminals.
4. Read resistance between all pairs of terminals using an ohmmeter on 0–10 ohm scale.
5. Determine 2 terminals that provide greatest resistance reading.

Through elimination, remaining terminal must be common (C). Greatest resistance between common (C) and another terminal indicates the start winding because it has more turns. This terminal is the start (S). The remaining terminal will be run winding (R).

NOTE: If compressor is hot, allow time to cool and internal line break to reset. There is an internal line break protector which must be closed.

All compressors are equipped with internal motor protection. If motor becomes hot for any reason, protector opens. Compressor should always be allowed to cool and protector to close before troubleshooting. Always turn off all power to unit and disconnect leads at compressor terminals before taking readings.

Most common motor failures are due to either an open, grounded, or short circuit. When a compressor fails to start or run, 3 tests can help determine the problem. First, all possible external causes should be eliminated, such as overloads, improper voltage, pressure equalization, defective capacitor(s), relays, wiring, etc. Compressor has internal line break overload, so be certain it is closed.

Open Circuit

⚠ WARNING

UNIT PERSONAL INJURY HAZARD

Failure to follow this warning could result in personal injury.

Use caution when working near compressor terminals. Damaged terminals have the potential to cause personal injury.

Never put face or body directly in line with terminals.

To determine if any winding has a break in the internal wires and current is unable to pass through, follow these steps:

1. Be sure all power is off.
2. Discharge all capacitors.
3. Remove wires from terminals C, S, and R.
4. Check resistance from C–R, C–S, and R–S using an ohmmeter on 0–1000 ohm scale.

Because winding resistances are usually less than 10 ohms, each reading appears to be approximately 0 ohm. If resistance remains at 1000 ohms, an open or break exists and compressor should be replaced.



CAUTION

UNIT DAMAGE HAZARD

Failure to follow this caution may result in equipment damage or improper operation.

Be sure internal line break overload is not temporarily open.

RECIPROCATING COMPRESSOR

The compressor is the heart of the refrigeration system. It pumps refrigerant through the system. If it malfunctions, system capacity and efficiency could be negatively affected.



WARNING

FIRE/EXPLOSION HAZARD

Failure to follow this warning could result in personal injury or death and/or property damage.

Wear safety glasses and gloves when handling refrigerants. Keep torches and other ignition sources away from refrigerants and oils.

The compressor is an electrical (as well as mechanical) device. Exercise extreme caution when working near compressors. Power should be shut off, if possible, for most troubleshooting techniques. Refrigerants in system present other safety hazards. Always wear safety glasses and gloves when handling refrigerants.

Compressor Failures

Compressor failures are classified in 2 broad failure categories: mechanical and electrical. Both types are discussed below.

Mechanical Failures

A compressor is a mechanical pump driven by an electric motor contained in a welded or hermetic shell. In a mechanical failure, motor or electrical circuit appears normal, but compressor does not function normally.



WARNING

ELECTRICAL SHOCK HAZARD

Failure to follow this warning could result in personal injury or death.

Before installing, modifying, or servicing system, main electrical disconnect switch must be in the OFF position. There may be more than 1 disconnect switch. Lock out and tag switch with a suitable warning label.

Locked Rotor

In this type of failure, compressor motor and all starting components are normal. When compressor attempts to start, it draws locked rotor current and cycles off on the internal protection. Locked rotor current is measured by applying a clamp-on ammeter around common (blk) lead of the compressor on a single-phase compressor. Current drawn when it attempts to start is then measured. LRA (locked rotor amp) value is stamped on compressor nameplate.

If compressor draws locked rotor amps and all other external sources of problems have been eliminated,

compressor must be replaced. Because compressor is a sealed unit, it is impossible to determine exact mechanical failure. However, complete system should be checked for abnormalities such as incorrect refrigerant charge, restrictions, insufficient airflow across indoor or outdoor coil, etc., which could be contributing to the failure.

Runs, Does Not Pump

In this type of failure, compressor motor runs and turns compressor, but compressor does not pump the refrigerant.

A clamp-on ammeter on common leg of a single-phase compressor, shows a very low current draw, much lower than RLA (rated load amps) value stamped on compressor nameplate. Because no refrigerant is being pumped, there is no return gas to cool compressor motor. It eventually overheats and shuts off on its internal protection.

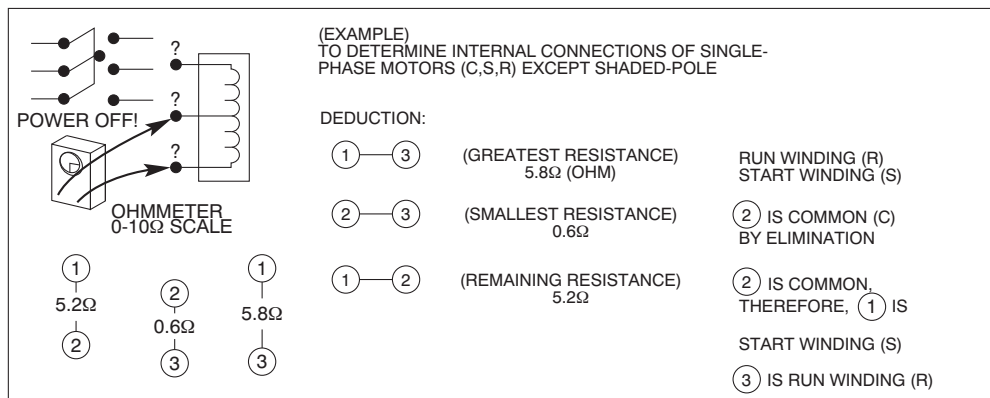

Figure 18 – Identifying Compressor Terminals

A88344

Runs, Does Not Pump, High-To-Low Side Leak

In this type of failure, compressor motor runs and turns compressor, and compressor is pumping. Usually, an internal problem such as blown head gasket or broken internal discharge line causes compressor to pump hot discharge gas back into its own shell rather than through system.

Using pressure gages on high flow service valves shows high suction and low discharge pressure readings. Motor currents are lower than normal. Because hot gas is being discharged into shell, the shell becomes hot. The hot gas causes compressor motor to cycle off on its internal protection.

Runs and Pumps, Low Capacity

This failure type is difficult to pinpoint because extent of damage varies. Compressor is a pump with internal valves that enable compressor to pump properly. The cylinder has a set of suction and discharge valves. Any of these parts may become damaged or broken, causing loss in pumping capacity. Severity of damage determines amount of capacity loss. Use pressure gages to find any abnormal system pressures if system charge and other conditions are normal. An owner may complain that a unit is not handling the building's heating or cooling load. The compressor current draw may be abnormally low or high. Although this type of failure does occur, all other possible causes of capacity loss must be eliminated before condemning compressor.

Noisy Compressor

Noise may be caused by a variety of internal problems such as loosened hardware, broken mounting springs, etc. System problems such as overcharged compressor (especially at start-up) or too much oil in compressor may also cause excessive noise. Excess oil in compressor is normally encountered only after a replacement compressor has been added without purging oil from previous compressor. As new compressor pumps, excess oil in system returns and adds to volume already present, causing noise.

Compressor Leaks

⚠ CAUTION

UNIT DAMAGE AND/OR PERSONAL INJURY HAZARD

Failure to follow this caution may result in personal injury and/or unit component damage.

High flow service valves are equipped with Schrader valves. Wear safety glasses and gloves when handling refrigerant.

Sometimes a leak is detected at weld seam around girth of compressor or a fitting that joins compressor shell. Many of these leaks can be repaired and the compressor saved if correct procedure is followed.

1. Turn off all power to unit.
2. Remove and recover all refrigerant from system so that gage pressures are 0 psig.
3. Clean area around leak to bare metal.
4. Apply flux and repair joint with silver solder. Do not use low temperature solder such as 50-50.
5. Clean off excess flux, check for leaks, and apply paint over repaired area to prevent corrosion.

Do not use this method to repair a compressor leak due to severe corrosion. Never attempt to repair a compressor leaking at electric terminals. This type of failure requires compressor replacement.

Electrical Failures

The compressor mechanical pump is driven by an electric motor within its hermetic shell. In electrical failures, compressor does not run although external electrical and mechanical systems appear normal. Compressor must be checked electrically for abnormalities.

Before troubleshooting compressor motor, review this description of compressor motor terminal identification.

Single-Phase Motors

To identify terminals C, S, and R:

1. Turn off all unit power.
2. Short the run and start capacitors to prevent shock.
3. Remove all wires from motor terminals.
4. Read resistance between all pairs of terminals using an ohmmeter on 0–10 ohm scale.
5. Determine 2 terminals that provide greatest resistance reading.

Through elimination, remaining terminal must be common (C). Greatest resistance between common (C) and another terminal indicates start winding because it has more turns. This terminal is start (S). Remaining terminal will be run winding (R). (See Figure 18.)

NOTE: If compressor is hot, allow time to cool and internal line break to reset. There is an internal line break protector which must be closed.

Open Circuit

To determine if any winding has a break in the internal wires and current is unable to pass through:

1. Be sure all power is off.
2. Discharge all capacitors.
3. Remove wires from terminals C, S and R.
4. Check resistance from C–R, C–S and R–S using an ohmmeter on 0–1000 ohm scale.

Because winding resistances are usually less than 10 ohms, each reading appears to be approximately 0 ohm. If resistance remains at 1000 ohms, an open or break exists and compressor should be replaced. Be sure internal line break overload is not temporarily open.

Ground Circuit

To determine if a wire has broken or come in direct contact with shell, causing a direct short to ground:

1. Be sure all power is off.
2. Discharge all capacitors.
3. Remove wires from terminals C, S, and R.
4. On hermetic compressors, allow crankcase heaters to remain on for several hours before checking motor to ensure windings are not saturated with refrigerant.
5. Use an ohmmeter on R X 10,000 ohm scale. A megohmmeter may be used in place of ohmmeter. Follow manufacturer's instructions.
6. Place 1 meter probe on ground or on compressor shell. Make a good metal-to-metal contact. Place other probe on terminals C, S, and R in sequence.
7. Note meter scale.
8. If reading of zero or low resistance is obtained, motor is grounded. Replace compressor.

A compressor of 1 ton capacity or less is probably grounded if resistance is below 1 million ohms. On larger sized single-phase compressors, resistance to ground should not be less than 1000 ohms per volt of operating voltage.

Example:

230 volts X 1000 ohms/volt = 230,000 ohms minimum.

SHORT CIRCUIT

To determine if any wires within windings have broken through their insulation and made contact with other wires, thereby shorting all or part of the winding(s), be sure the following conditions are met:

1. Correct motor winding resistances must be known before testing, either from previous readings or from manufacturer's specifications.
2. Temperature of windings must be as specified, usually about 70°F (21.1°C).

3. Resistance measuring instrument must have an accuracy within ± 5 –10 percent. This requires an accurate ohmmeter such as a Wheatstone bridge or null balance-type instrument.
4. Motor must be dry or free from direct contact with liquid refrigerant.

Make This Critical Test

(Not advisable unless above conditions are met.)

1. Be sure all power is off.
2. Discharge all capacitors.
3. Remove wires from terminals C, S, and R.
4. Place instrument probes together and determine probe and lead wire resistance.
5. Check resistance readings from C–R, C–S, and R–S.
6. Subtract instrument probe and lead resistance from each reading.

If any reading is within ± 20 percent of known resistance, motor is probably normal. Usually a considerable difference in reading is noted if a turn-to-turn short is present.

System Clean-Up After Burnout

Turn off all power to unit before proceeding. Wear safety glasses and gloves when handling refrigerants. Acids formed as a result of motor burnout can cause burns.

NOTE: To analyze level of suspected contamination from compressor burnout, use Total Test™. See your distributor/branch.

Some compressor electrical failures can cause motor to overheat. When this occurs, byproducts, which include sludge, carbon, and acids, contaminate system. If burnout is severe enough, system must be cleaned before replacement compressor is installed. The 2 types of motor burnout are classified as mild or severe.

In mild burnout, there is little or no detectable odor. Compressor oil is clear or slightly discolored. An acid test of compressor oil will be negative. This type of failure is treated the same as mechanical failure. Liquid line strainer should be removed and liquid line filter drier installed.

In a severe burnout, there is a strong, pungent, rotten egg odor. Compressor oil is very dark. Evidence of burning may be present in tubing connected to compressor. An acid test of compressor oil will be positive. Complete system must be reverse flushed with refrigerant. Metering device must be cleaned or replaced. In a heat pump, accumulator and reversing valve are replaced. These components are also removed and bypassed during reverse flushing procedure. Remove and discard liquid line strainer. After system is reassembled, install liquid and suction line filter driers. Run system for 2 hrs. Discard both driers and install new liquid line drier only.

Compressor Removal and Replacement

Once it is determined that compressor has failed and the reason established, compressor must be replaced.



CAUTION

PERSONAL INJURY HAZARD

Failure to follow this caution may result in personal injury. Wear safety glasses, protective clothing, and gloves when handling refrigerant and observe the following:

The high flow service valve is equipped with Schrader valves.

⚠ WARNING

PERSONAL INJURY AND ENVIRONMENTAL HAZARD

Failure to follow this warning could result in personal injury or death. Relieve pressure and recover all refrigerant before system repair or final unit disposal. Use all service ports and open all flow-control devices, including solenoid valves. Federal regulations require that you do not vent refrigerant to the atmosphere. Recover during system repair or final unit disposal.

1. Shut off all power to unit.
2. Remove and recover all refrigerant from system until pressure gages read zero psig. Use all service ports.
3. Disconnect electrical plug from compressor. Disconnect or remove crankcase heater (if equipped) and remove compressor holddown nuts and washers.
4. Cut compressor from system with tubing cutters. Do not use brazing torch for compressor removal. Oil vapor may ignite when compressor is disconnected.
5. Scratch matching marks on stubs in old compressor. Make corresponding marks on replacement compressor.
6. Use torch to remove stubs from old compressor and to reinstall them in replacement compressor.
7. Use copper couplings to tie compressor back into system.
8. Evacuate system, recharge, and check for normal system operation.
9. Compressors have copper plated steel suction ports. Excess heat during brazing will burn off copper plating. See Brazing section for additional information.

Outdoor Fan Adjustment

⚠ CAUTION

UNIT OPERATION HAZARD

Failure to follow this caution may result in damage to unit components.

Keep the condenser fan free from all obstructions to ensure proper cooling operation. Never place articles on top of unit.

1. Shut off unit power supply and install lockout tag.
2. Remove outdoor-fan assembly (grille, motor, motor cover, and fan) by removing screws and flipping assembly onto unit top cover.
3. Inspect the fan blades for cracks or bends.
4. If fan needs to be removed, loosen the setscrew and slide the fan off the motor shaft.
5. When replacing fan blade, position blade as shown in Figure 19. Tighten setscrews.

Fan Motor

The fan motor rotates the fan blade that draws air through the outdoor coil to exchange heat between the refrigerant and the air. Motors are totally enclosed to increase reliability. This eliminates the need for a rain shield. For the correct position of fan blade assembly, the fan hub should be flush with the motor shaft. Replacement motors and blades may vary slightly.

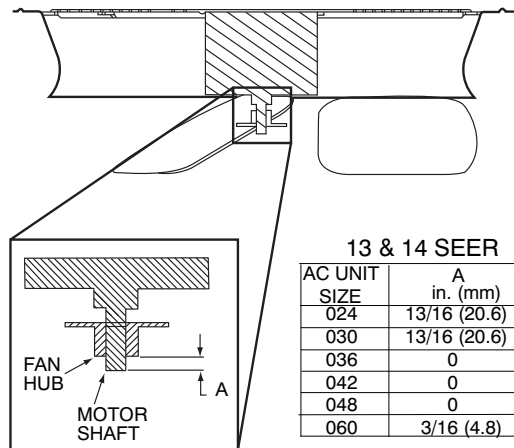

13 & 14 SEER	
AC UNIT SIZE	A in. (mm)
024	13/16 (20.6)
030	13/16 (20.6)
036	0
042	0
048	0
060	3/16 (4.8)

A14540

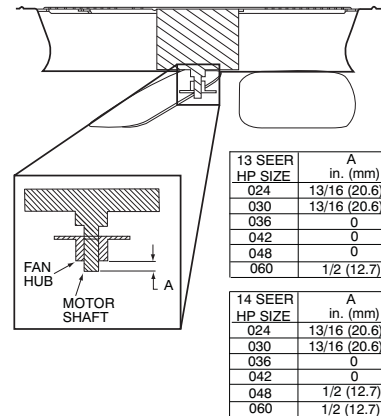

13 SEER	
HP SIZE	A in. (mm)
024	13/16 (20.6)
030	13/16 (20.6)
036	0
042	0
048	0
060	1/2 (12.7)

14 SEER	
HP SIZE	A in. (mm)
024	13/16 (20.6)
030	13/16 (20.6)
036	0
042	0
048	1/2 (12.7)
060	1/2 (12.7)

A150078

Figure 19 – Outdoor Fan Adjustment

⚠ WARNING

ELECTRICAL SHOCK HAZARD

Failure to follow this warning could result in personal injury or death.

Turn off all power before servicing or replacing fan motor. Be sure unit main power switch is turned off. Lock out and tag with suitable warning label.

The bearings are permanently lubricated, therefore, no oil ports are provided.

For suspected electrical failures, check for loose or faulty electrical connections, or defective fan motor capacitor. Fan motor is equipped with thermal overload device in motor windings which may open under adverse operating conditions. Allow time for motor to cool so device can reset. Further checking of motor can be done with an ohmmeter. Set scale on R X 1 position, and check for continuity between 3 leads. Replace motors that show an open circuit in any of the windings. Place 1 lead of ohmmeter on each motor lead. At same time, place other ohmmeter lead on motor case (ground). Replace any motor that shows resistance to ground, arcing, burning, or overheating.

Compressor Plug

The compressor electrical plug provides a quick-tight connection to compressor terminals. The plug completely covers the compressor terminals and the mating female terminals are completely encapsulated in plug. Therefore, terminals are isolated from any moisture so corrosion and resultant pitted or discolored terminals are reduced. The

plug is oriented to relief slot in terminal box so cover cannot be secured if wires are not positioned in slot, assuring correct electrical connection at the compressor. The plug can be removed by simultaneously pulling while “rocking” plug. However, these plugs can be used only on specific compressors. The configuration around the fusite terminals is outlined on the terminal covers. The slot through which wires of plug are routed is oriented on the bottom and slightly to the left. The correct plug can be connected easily to compressor terminals and plug wires can easily be routed through slot terminal cover.

It is strongly recommended to replace the compressor plug should a compressor fail due to a suspected electrical failure. At a minimum, inspect plug for proper connection and good condition on any compressor replacement.

Low-Voltage Terminals

The low-voltage terminal designations, and their description and function, are used on all Small Packaged Products (SPP) condensers.

W—Energizes first-stage supplemental heat.

R—Energizes 24-v power from transformer.

Y—Energizes contactor for first-stage cooling or first-stage heating for heat pumps.

O—Energizes reversing valve on heat pumps.

C—Common side of transformer.

G—Indoor Fan

Ground Circuit

To determine if a wire has broken or come in direct contact with shell, causing a direct short to ground, follow these steps:

1. Recover all refrigerant charge.
2. Using an ohmmeter on R X 10,000 ohm scale or megohmmeter (follow manufacturer’s instructions).
3. Be sure all power is off.
4. Discharge all capacitors.
5. Remove compressor plug.
6. Place one meter probe on ground or on compressor shell. Make a good metal-to-metal contact. Place other probe on terminals C, S, and R in sequence.
7. Note meter scale.
8. If reading of 0 or low resistance is obtained, motor is grounded. Replace compressor.

Compressor resistance to ground should not be less than 1000 ohms per volt of operating voltage.

Example:

230 volts X 1000 ohms/volt = 230,000 ohms minimum.

Short Circuit

To determine if any wires within windings have broken through their insulation and made contact with other wires, thereby shorting all or part of the winding(s), be sure the following conditions are met.

1. Correct motor winding resistances must be known before testing, either from previous readings or from manufacturer’s specifications.
2. Temperature of windings must be as specified, usually about 70°F (21°C).
3. Resistance measuring instrument must have an accuracy within \pm 5–10 percent. This requires an accurate ohmmeter such as a Wheatstone bridge or null balance-type instrument.
4. Motor must be dry or free from direct contact with liquid refrigerant.

Make This Critical Test

(Not advisable unless above conditions are met)

1. Be sure all power is off.
2. Recover all refrigerant charge.
3. Discharge all capacitors.
4. Remove wires from terminals C, S, and R.
5. Place instrument probes together and determine probe and lead wire resistance.
6. Check resistance readings from C–R, C–S, and R–S.
7. Subtract instrument probe and lead resistance from each reading.

If any reading is within \pm 20 percent of known resistance, motor is probably normal. Usually a considerable difference in reading is noted if a turn-to-turn short is present.

REFRIGERATION SYSTEM

Refrigerant

WARNING

UNIT OPERATION AND SAFETY HAZARD

Failure to follow this warning could result in personal injury or equipment damage.

R-410A refrigerant which has higher pressures than R-22 and other refrigerants. No other refrigerant may be used in this system. Gauge set, hoses, and recovery system must be designed to handle R-410A. If you are unsure consult the equipment manufacturer.

In an air conditioning and heat pump system, refrigerant transfers heat from one replace to another. The condenser is the outdoor coil in the cooling mode and the evaporator is the indoor coil.

In a heat pump, the condenser is the indoor coil in the heating mode and the evaporator is the outdoor coil.

In the typical air conditioning mode, compressed hot gas leaves the compressor and enters the condensing coil. As gas passes through the condenser coil, it rejects heat and condenses into liquid. The liquid leaves condensing unit through liquid line and enters metering device at evaporator coil. As it passes through metering device, it becomes a gas-liquid mixture. As it passes through indoor coil, it absorbs heat and the refrigerant moves to the compressor and is again compressed to hot gas, and cycle repeats.

Compressor Oil

CAUTION

UNIT DAMAGE HAZARD

Failure to follow this caution may result in equipment damage or improper operation.

The compressor in a R-410A system uses a polyolester (POE) or polyvinyl ether (PVE) oil. This oil is extremely hygroscopic, meaning it absorbs water readily. POE/PVE oils can absorb 15 times as much water as other oils designed for HCFC and CFC refrigerants. Take all necessary precautions to avoid exposure of the oil to the atmosphere. (See Table 3.)

Brazing

This section on brazing is not intended to teach a technician how to braze. There are books and classes which teach and

refine brazing techniques. The basic points below are listed only as a reminder.

Definition: The joining and sealing of metals using a nonferrous metal having a melting point over 800°F/426.6°C.

Flux: A cleaning solution applied to tubing or wire before it is brazed. Flux improves the strength of the brazed connection.

When brazing is required in the refrigeration system, certain basics should be remembered. The following are a few of the basic rules.

1. Clean joints make the best joints. To clean:
 - Remove all oxidation from surfaces to a shiny finish before brazing.
 - Remove all flux residue with brush and water while material is still hot.
2. Silver brazing alloy is used on copper-to-brass, copper-to-steel, or copper-to-copper. Flux is required when using silver brazing alloy. Do not use low temperature solder.
3. Fluxes should be used carefully. Avoid excessive application and do not allow fluxes to enter into the system.
4. Brazing temperature of copper is proper when it is heated to a minimum temperature of 800°F (426.6°C) and it is a dull red color in appearance.

Reversing Valve

In heat pumps, changeover between heating and cooling modes is accomplished with a valve that reverses flow of refrigerant in system. This reversing valve device is easy to troubleshoot and replace. The reversing valve solenoid can be checked with power off with an ohmmeter. Check for continuity and shorting to ground. With control circuit (24v) power on, check for correct voltage at solenoid coil. Check for overheated solenoid.

With unit operating, other items can be checked, such as frost or condensate water on refrigerant tubes.

The sound made by a reversing valve as it begins or ends defrost is a “whooshing” sound, as the valve reverses and

pressures in system equalize. An experienced service technician detects this sound and uses it as a valuable troubleshooting tool.

Using a remote measuring device, check inlet and outlet line temperatures. **DO NOT** touch lines. If reversing valve is operating normally, inlet and outlet temperatures on appropriate lines should be close to each other. Any difference would be due to heat loss or gain across valve body. Temperatures are best checked with a remote reading electronic-type thermometer with multiple probes. Route thermocouple leads to inside of coil area through service valve mounting plate area underneath coil. Figure 20 and Figure 21 show test points (TP) on reversing valve for recording temperatures. Insulate points for more accurate reading.

If valve is defective:

1. Shut off all power to unit and remove charge from system.
2. Remove solenoid coil from valve body. Remove valve by cutting it from system with tubing cutter. Repair person should cut in such a way that stubs can be easily re-brazed back into system. Do not use hacksaw. This introduces chips into system that cause failure. After defective valve is removed, wrap it in wet rag and carefully unbrazed stubs. Save stubs for future use. Because defective valve is not overheated, it can be analyzed for cause of failure when it is returned.
3. Braze new valve onto used stubs. Keep stubs oriented correctly. Scratch corresponding matching marks on old valve and stubs and on new valve body to aid in lining up new valve properly. When brazing stubs into valve, protect valve body with wet rag to prevent overheating.
4. Use slip couplings to install new valve with stubs back into system. Even if stubs are long, wrap valve with a wet rag to prevent overheating.
5. After valve is brazed in, check for leaks. Evacuate and charge system. Operate system in both modes several times to be sure valve functions properly.

**Table 3 – Compressor Information
13 SEER Air Conditioner**

Unit Size	24	30	36	42	48	60
Type	AC	AC	AC	AC	AC	AC
Chassis Size	Small	Small	Small	Medium	Medium	Large
Compressor	Bristol Recip	Bristol Recip	Bristol Recip	Bristol Recip	Copeland Scroll	Danfoss Scroll
Manufacturer Oil Type	Hatcol 32BCE Polyolester (POE)	Hatcol 32BCE Polyolester (POE)	Hatcol 32BCE Polyolester (POE)	Hatcol 32BCE Polyolester (POE)	3MAF Polyolester Oil (POE)	Polyvinyl Ether Oil (PVE)
Oil Charge - fl.oz. (initial/recharge)	30 / 27	30 / 27	40 / 37	40 / 37	42 / 34	45 / 39
Winding Resistance -ohm (Start C-R)	1.43	0.98	0.63	0.52	0.52	0.43
Winding Resistance -ohm (Start C-S)	2.38	1.73	1.26	1.64	0.82	1.06
Winding Resistance -ohm (Start R-S)	3.81	2.71	1.89	2.16	1.34	1.5
Run Capacitor (mfd / volts)	35 / 440	35 / 440	40 / 440	45 / 440	70 / 440	70 / 440

14 SEER Air Conditioner

Unit Size	24	30	36	42	48	60
Type	AC	AC	AC	AC	AC	AC
Chassis Size	Small	Small	Small	Medium	Large	Large
Compressor	Bristol Recip	Bristol Recip	Bristol Recip	LG Scroll	Copeland Scroll	Copeland Scroll
Manufacturer Oil Type	Hatcol 32BCE Polyolester (POE)	Hatcol 32BCE Polyolester (POE)	Hatcol 32BCE Polyolester (POE)	RB32G Polyolester (POE)	3MAF Polyolester Oil (POE)	3MAF Polyolester Oil (POE)
Oil Charge - fl.oz. (initial/recharge)	30 / 27	30 / 27	30 / 27	43 / 35	42 / 36	42 / 36
Winding Resistance -ohm (Start C-R)	1.43	0.98	0.82	0.67	.464–.534 / .499 avg.	.391–.449 / .420 avg.
Winding Resistance -ohm (Start C-S)	2.38	1.73	1.63	1.46	.753–.867/.810 avg.	.814–.936 / .875 avg.
Winding Resistance -ohm (Start R-S)	3.81	2.71	2.45	2.13	1.31	1.30
Run Capacitor (mfd / volts)	35 / 440	40 / 440	45 / 440	45 / 440	70 / 440	70 / 440

13 SEER Heat Pump

Unit Size	24	30	36	42	48	60
Type	HP	HP	HP	HP	HP	HP
Chassis Size	Small	Small	Medium	Large	Large	Large
Compressor	Copeland Scroll	Copeland Scroll	Copeland Scroll	Copeland Scroll	Copeland Scroll	Copeland Scroll
Manufacturer Oil Type	3MAF Polyolester Oil (POE)	3MAF Polyolester Oil (POE)	3MAF Polyolester Oil (POE)	3MAF Polyolester Oil (POE)	3MAF Polyolester Oil (POE)	3MAF Polyolester Oil (POE)
Oil Charge - fl.oz. (initial/recharge)	25 / 19	25 / 21	25 / 19	25 / 19	42 / 34	42 / 34
Winding Resistance -ohm (Start C-R)	1.23	0.98	0.87	0.56	0.52	0.45
Winding Resistance -ohm (Start C-S)	1.47	1.78	1.47	1.25	0.82	0.79
Winding Resistance -ohm (Start R-S)	2.7	2.76	2.34	1.81	1.34	1.24
Run Capacitor (mfd / volts)	40 / 440	40 / 440	45 / 440	45 / 440	70 / 440	70 / 440

14 SEER Heat Pump

Unit Size	24	30	36	42	48	60
Type	HP	HP	HP	HP	HP	HP
Chassis Size	Small	Medium	Medium	Large	Large	Large
Compressor	Copeland Scroll	Copeland Scroll	LG Scroll	LG Scroll	LG Scroll	Copeland Scroll
Manufacturer Oil Type	3MAF Polyolester Oil (POE)	3MAF Polyolester Oil (POE)	RB32G Polyolester Oil (POE)	RB32G Polyolester Oil (POE)	RB32G Polyolester Oil (POE)	3MAF Polyolester Oil (POE)
Oil Charge - fl.oz. (initial/recharge)	21 / 17	25 / 21	25 / 19	43 / 35	43 / 35	42 / 36
Winding Resistance -ohm (Start C-R)	1.212-1.394 / 1.303 avg.	.949-1.091 / 1.020 avg.	0.90	0.67	0.70	0.45
Winding Resistance -ohm (Start C-S)	1.523-1.753 / 1.638 avg.	1.772-2.038 / 1.905 avg.	1.30	1.46	0.82	0.79
Winding Resistance -ohm (Start R-S)	2.94	2.93	2.20	2.13	1.50	1.24
Run Capacitor (mfd / volts)	40 / 440	35 / 440	45 / 440	45 / 440	70 / 440	70 / 440

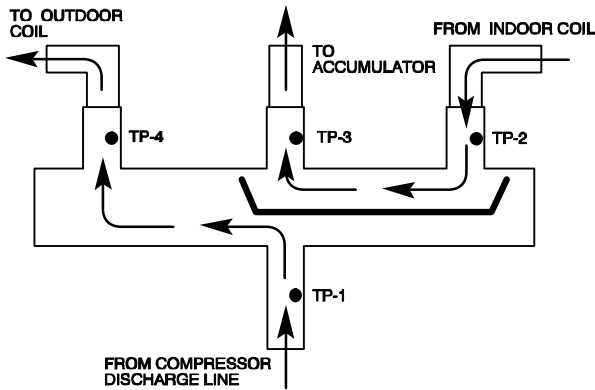

A10189

Figure 20 – Reversing Valve (Cooling Mode or Defrost Mode, Solenoid Energized)

Liquid Line Filter Drier

Filter driers are specifically designed for R-410A refrigerant. Only operate with the appropriate drier using factory authorized components.

There is a liquid line drier located inside the unit in the compressor section. The liquid line drier also acts as a strainer.

Suction Line Filter Drier

The suction line drier is specifically designed to operate with R-410A, use only factory authorized components. Suction line filter drier is used in cases where acid might occur, such as burnout. Heat pump units must have the drier installed between the compressor and accumulator only. Remove after 10 hours of operation. Never leave suction line filter drier in a system longer than 72 hours (actual time).

Accumulator

The accumulator is specifically designed to operate with R-410A pressures; use only factory-authorized components. Under some light load conditions on indoor coils, liquid refrigerant is present in suction gas returning to compressor. The accumulator stores liquid and allows it to boil off into a vapor so it can be safely returned to compressor. Since a compressor is designed to pump refrigerant in its gaseous state, introduction of liquid into it could cause severe damage or total failure of compressor.

The accumulator is a passive device which seldom needs replacing. Occasionally its internal oil return orifice or bleed hole may become plugged. Some oil is contained in accumulator returning to compressor. It cannot boil off in accumulator with liquid refrigerant. The bleed hole allows a small amount of oil and refrigerant to enter the return line where velocity of refrigerant returns it to compressor. If bleed hole plugs, oil is trapped in accumulator, and compressor will eventually fail from lack of lubrication. If bleed hole is plugged, accumulator must be changed. The accumulator has a fusible element located in the bottom end bell. (See Figure 22.) This fusible element will melt at 430°F/221°C and vent the refrigerant if this temperature is reached either internal or external to the system. If fuse melts, the accumulator must be replaced.

To change accumulator:

1. Shut off all power to unit.
2. Recover all refrigerant from system.
3. Break vacuum with dry nitrogen. Do not exceed 5 psig.

NOTE: Refer to appropriate sections of Service Manual for instructions.

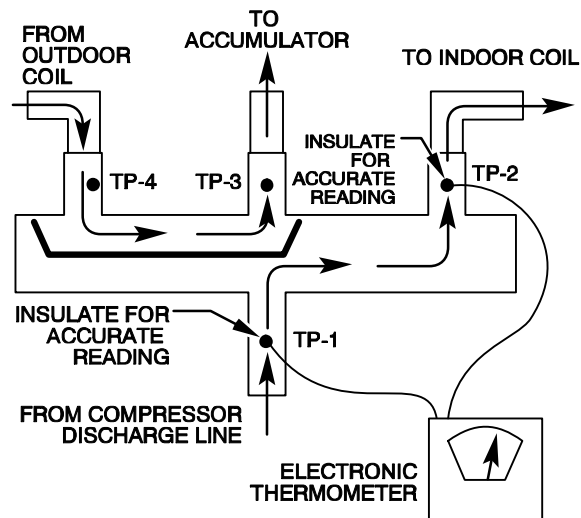

A10188

Figure 21 – Reversing Valve (Heating Mode, Solenoid De-Energized)

CAUTION

PERSONAL INJURY HAZARD

Failure to follow this caution may result in personal injury.

Wear safety glasses, protective clothing, and gloves when handling refrigerant.

4. Remove accumulator from system with tubing cutter.
5. Tape ends of open tubing.
6. Scratch matching marks on tubing studs and old accumulator. Scratch matching marks on new accumulator. Unbrazed stubs from old accumulator and braze into new accumulator.
7. Thoroughly rinse any flux residue from joints and paint with corrosion-resistant coating such as zinc-rich paint.
8. Install factory authorized accumulator into system with copper slip couplings.
9. Evacuate and charge system.

Pour and measure oil quantity (if any) from old accumulator. If more than 20 percent of oil charge is trapped in accumulator, add new POE or PVE oil to compressor to make up for this loss. (See Table 3.)

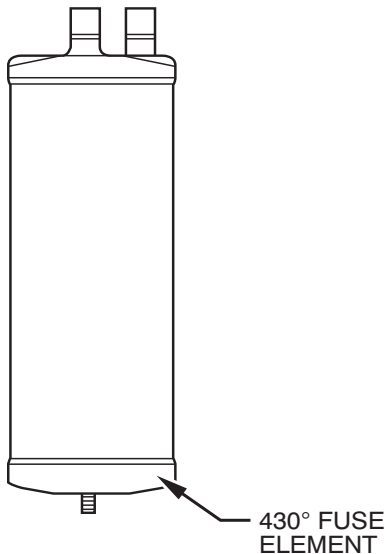

Figure 22 – Accumulator

A88410

Thermostatic Expansion Valve (TXV)

The five ton air conditioning and heat pump units have a factory installed thermostatic expansion valve (TXV). The TXV will be a bi-flow, hard-shutoff with an external equalizer and a balance port pin. A hard shut-off TXV does not have a bleed port. Therefore, minimal equalization takes place after shutdown. TXVs are specifically designed to operate with R-410A refrigerant, use only factory authorized TXV's. **Do not interchange R-410A and R-22 TXVs.**

TXV Operation

The TXV is a metering device that is used in air conditioning and heat pump systems to adjust to changing load conditions by maintaining a preset superheat temperature at the outlet of the evaporator coil. The volume of refrigerant metered through the valve seat is dependent upon the following:

1. Superheat temperature is sensed by cap tube sensing bulb on suction tube at outlet of evaporator coil. This temperature is converted into pressure by refrigerant in the bulb pushing downward on the diaphragm which opens the valve via the pushrods.
2. The suction pressure at the outlet of the evaporator coil is transferred via the external equalizer tube to the underside of the diaphragm. This is needed to account for the indoor coil pressure drop. Coils typically have a high pressure drop, which requires this valve feature.
3. The pin is spring loaded, which exerts pressure on the underside of the diaphragm. Therefore, the bulb pressure works against the spring pressure and evaporator suction pressure to open the valve. If the load increases, the temperature increases at the bulb, which increases the pressure on the top side of the diaphragm. This opens the valve and increases the flow of refrigerant. The increased refrigerant flow causes the leaving evaporator temperature to decrease. This lowers the pressure on the diaphragm and closes the pin. The refrigerant flow is effectively stabilized to the load demand with negligible change in superheat.

Table 4 – Piston/TXV Table

Air Conditioner

Unit Size (ton)	Indoor Cooling Piston/TXV Number	Outdoor Heating Piston Number
13 SEER		
24	59	--
24	59	--
30	59	--
36	67	--
42	73	--
48	82	--
60	TXV	--
14 SEER		
24	57	--
30	63	--
36	67	--
42	76	--
48	80	--
60	TXV	--

Heat Pump

Unit Size (ton)	Indoor Cooling Piston/TXV Number	Outdoor Heating Piston Number
13 SEER		
24	59	49
30	59	49
36	70	57
42	73	61
48	82	70
60	TXV	73
14 SEER		
24	59	TXV
30	59	49
36	67	57
42	76	59
48	TXV	TXV
60	TXV	70

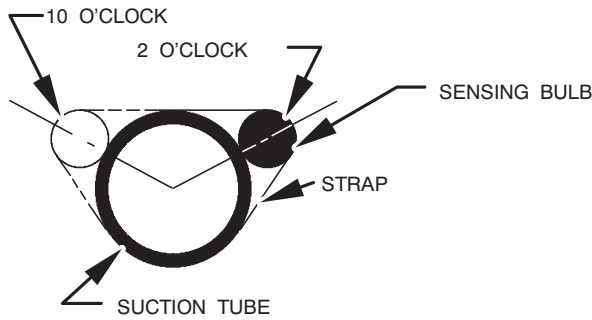

Figure 23 – Position of Sensing Bulb

A08083

PISTON BODY CLEANING OR REPLACEMENT

⚠ WARNING

PERSONAL INJURY AND ENVIRONMENTAL HAZARD

Failure to relieve system pressure could result in personal injury and/or death.

1. Relieve pressure and recover all refrigerant before servicing existing equipment, and before final unit disposal. Use all service ports.
2. Federal regulations require that you do not vent refrigerant into the atmosphere. Recover during system repair or final unit disposal.

⚠ CAUTION

UNIT DAMAGE HAZARD

Failure to follow this caution may result in equipment damage.

Damage may occur to the scroll compressor if operated at a negative suction pressure during a system pumpdown.

1. Recover refrigerant from tubing and coil through high flow service port on suction and discharge lines. Disconnect refrigerant (liquid) tube from distributor body. (See Figure 24.)
2. Avoid damaging seal ring or machined surfaces on piston, bore, and retainer.
3. Using small wire with a hook on end of it, remove piston from body.

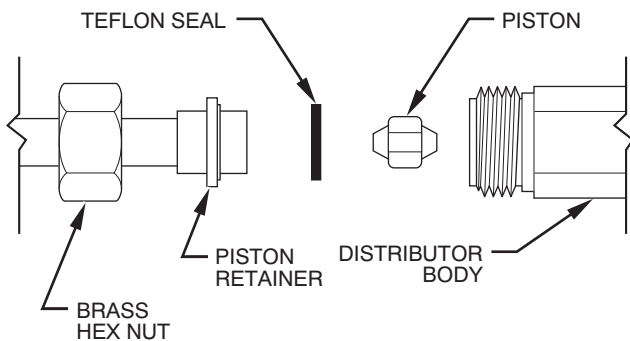

Figure 24 – Refrigerant Flow-Control Device

A10176

⚠ CAUTION

UNIT DAMAGE HAZARD

Failure to follow this caution may result in equipment damage.

When cleaning the piston orifice, be careful not to scratch or enlarge the opening, as this will affect operation.

4. Install new or cleaned piston into body.
5. Replace seal ring on retainer.
6. Reconnect refrigerant tube to piston body.
7. Pressurize tubing and coil, then leak check.
8. Evacuate tubing and coil as necessary.

⚠ CAUTION

UNIT DAMAGE HAZARD

Failure to follow this caution may result in equipment damage.

Use a backup wrench and do not over tighten, as deformation of the piston body will occur, causing the piston to lodge in a partially open or closed position.

LIQUID TUBE STRAINER/FILTER

The TXV and refrigerant flow-control device is protected by either a wire mesh strainer or filter drier.

REFRIGERATION SYSTEM REPAIR

⚠ WARNING

EXPLOSION HAZARD

Failure to follow this warning could result in death, serious personal injury, and/or property damage.

Never use air or gases containing oxygen for leak testing or operating refrigerant compressors. Pressurized mixtures of air or gases containing oxygen can lead to an explosion.

Leak Detection

New installations should be checked for leaks prior to complete charging. If a system has lost all or most of its charge, system must be pressurized again to approximately 150 psig minimum and 375 psig maximum. This can be done by adding refrigerant using normal charging procedures or by pressurizing system with nitrogen (less expensive than refrigerant). Nitrogen also leaks faster than refrigerants. Nitrogen cannot, however, be detected by an electronic leak detector. (See Figure 25.)

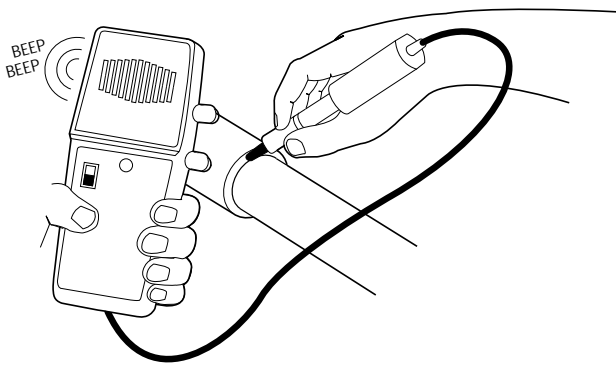

Figure 25 – Electronic Leak Detection

A95422

⚠ WARNING

PERSONAL INJURY AND UNIT DAMAGE HAZARD

Failure to follow this warning could result in personal injury or death.

Due to the high pressure of nitrogen, it should never be used without a pressure regulator on the tank.

Assuming that a system is pressurized with either all refrigerant or a mixture of nitrogen and refrigerant, leaks in the system can be found with an electronic leak detector that is capable of detecting specific refrigerants.

If system has been operating for some time, first check for a leak visually. Since refrigerant carries a small quantity of oil, traces of oil at any joint or connection is an indication that refrigerant is leaking at that point.

A simple and inexpensive method of testing for leaks is to use soap bubbles. (See Figure 26.) Any solution of water and soap may be used. Soap solution is applied to all joints and connections in system. A small pinhole leak is located by tracing bubbles in soap solution around leak. If the leak is very small, several minutes may pass before a bubble will form. Popular commercial leak detection solutions give better, longer-lasting bubbles and more accurate results than plain soapy water. The bubble solution must be removed from the tubing and fittings after checking for leaks as some solutions may corrode the metal.

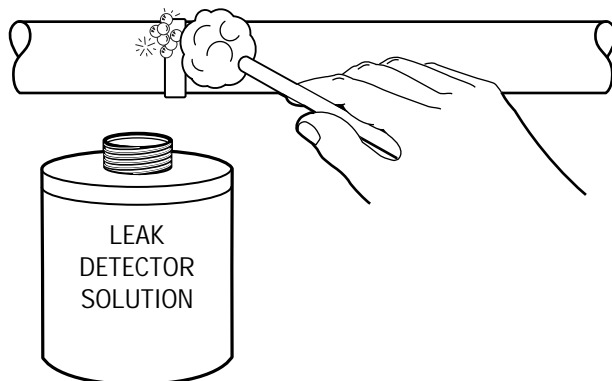

Figure 26 – Bubble Leak Detection

A95423

You may use an electronic leak detector designed for specific refrigerant to check for leaks. (See Figure 25.) This unquestionably is the most efficient and easiest method for checking leaks. There are various types of electronic leak detectors. Check with manufacturer of equipment for suitability. Generally speaking, they are portable, lightweight, and consist of a box with several switches and a probe or sniffer. Detector is turned on and probe is passed around all fittings and connections in system. Leak is detected by either the movement of a pointer on detector dial, a buzzing sound, or a light.

In all instances when a leak is found, system charge must be recovered and leak repaired before final charging and operation. After leak testing or leak is repaired, replace liquid line filter drier, evacuate system, and recharge with correct refrigerant quantity.

Coil Removal

Coils are easy to remove if required for compressor removal, or to replace coil.

1. Shut off all power to unit.
2. Recover refrigerant from system through high flow service valves.
3. Break vacuum with nitrogen.
4. Remove top cover. (See Access Compressor or other internal cabinet component, Figure 6 – Figure 8.)
5. Remove screws in coil panels.

⚠ WARNING

FIRE HAZARD

Failure to follow this warning could result in personal injury or equipment damage.

Cut tubing to reduce possibility of personal injury and fire.

6. Use midget tubing cutter to cut liquid and vapor lines at both sides of coil. Cut in convenient location for easy reassembly with copper slip couplings.
7. Lift coil vertically from basepan and carefully place aside.
8. Reverse procedure to reinstall coil.
9. Replace filter drier, evacuate system, recharge, and check for normal systems operation.

Compressor Removal and Replacement

Once it is determined that compressor has failed and the reason established, compressor must be replaced.

⚠ CAUTION

PERSONAL INJURY HAZARD

Failure to follow this caution may result in personal injury.

Turn off all power to unit before proceeding. Lock out and tag switch with suitable warning label. Wear safety glasses, protective clothing, and gloves when handling refrigerant. Acids formed as a result of motor burnout can cause burns.

⚠ CAUTION

PERSONAL INJURY HAZARD

Failure to follow this caution may result in personal injury.

Wear safety glasses, protective clothing, and gloves when handling refrigerant and when using brazing torch..

1. Shut off all power to unit.
2. Remove and recover all refrigerant from system until pressure gauges read 0 psig. Use all service ports. Never open a system under a vacuum to atmosphere. Break vacuum with dry nitrogen holding charge first. Do not exceed 5 psig.
3. Disconnect electrical leads from compressor. Disconnect or remove crankcase heater and remove compressor hold-down bolts.
4. Cut compressor from system with tubing cutter. Do not use brazing torch for compressor removal. Oil vapor may ignite when compressor is disconnected.
5. Scratch matching marks on stubs in old compressor. Make corresponding marks on replacement compressor.
6. Use torch to remove stubs from old compressor and to reinstall them in replacement compressor.
7. Use copper couplings to tie compressor back into system.
8. Replace filter drier, evacuate system, recharge, and check for normal system operation.

⚠ CAUTION

UNIT DAMAGE HAZARD

Failure to follow this caution may result in equipment damage or improper operation.

Do not leave system open to atmosphere. Compressor oil is highly susceptible to moisture absorption.

System Clean-Up After Burnout

Some compressor electrical failures can cause motor to burn. When this occurs, by-products of burn, which include sludge, carbon, and acids, contaminate system. Test the oil for acidity using POE oil acid test to determine burnout severity. If burnout is severe enough, system must be cleaned before replacement compressor is installed. The 2 types of motor burnout are classified as mild or severe.

In mild burnout, there is little or no detectable odor. Compressor oil is clear or slightly discolored. An acid test of compressor oil will be negative. This type of failure is treated the same as mechanical failure. Liquid-line strainer should be removed and liquid-line filter drier replaced.

In a severe burnout, there is a strong, pungent, rotten egg odor. Compressor oil is very dark. Evidence of burning may be present in tubing connected to compressor. An acid test of compressor oil will be positive. Follow these additional steps:

1. TXV must be cleaned or replaced.
2. Drain any trapped oil from accumulator if used.
3. Remove and discard liquid-line strainer and filter drier.

4. After system is reassembled, install liquid and suction-line R-410A filter driers.

NOTE: On heat pumps, install suction line drier between compressor and accumulator.

5. Operate system for 10 hr. Monitor pressure drop across drier. If pressure drop exceeds 3 psig replace suction-line and liquid-line filter driers. Be sure to purge system with dry nitrogen when replacing filter driers. If suction line driers must be replaced, retest pressure drop after additional 10 hours (run time). Continue to monitor pressure drop across suction line filter drier. After 10 hr of run time, remove suction-line filter drier and replace liquid-line filter drier. Never leave suction-line filter drier in system longer than 72 hr (actual time).
6. Charge system. (See unit information plate.)

⚠ CAUTION

UNIT DAMAGE HAZARD

Failure to follow this caution may result in equipment damage or improper operation.

Only suction line filter driers should be used for refrigerant and oil clean up. Use of non-approved products could limit system life and void unit warranty.

Evacuation

Proper evacuation of the system will remove non-condensibles and assure a tight, dry system before charging. The 2 methods used to evacuate a system are the deep vacuum method and the triple evacuation method.

Deep Vacuum Method

The deep vacuum method requires a vacuum pump capable of pulling a vacuum of 500 microns and a vacuum gauge capable of accurately measuring this vacuum depth. The deep vacuum method is the most positive way of assuring a system is free of air and moisture. (See Figure 27.)

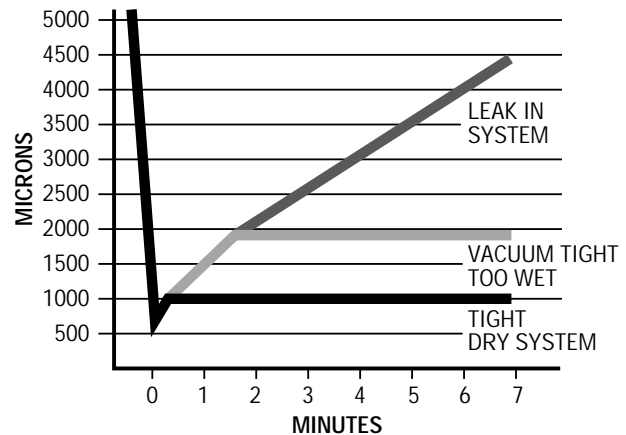

Figure 27 – Deep Vacuum Graph

A95424

Triple Evacuation Method

The triple evacuation method should be used when vacuum pump is only capable of pumping down to 28 in. of mercury vacuum and system does not contain any liquid water. Refer to Figure 28 and proceed as follows:

1. Pump system down to 28 in. of mercury and allow pump to continue operating for an additional 15 minutes.
2. Shut off vacuum pump.
3. Connect a nitrogen cylinder and regulator to system and open until system pressure is 2 psig.
4. Allow system to stand for 1 hr. During this time, dry nitrogen will be able to diffuse throughout the system absorbing moisture.
5. Repeat this procedure as indicated in Figure 28. System will then be free of any contaminants and water vapor.

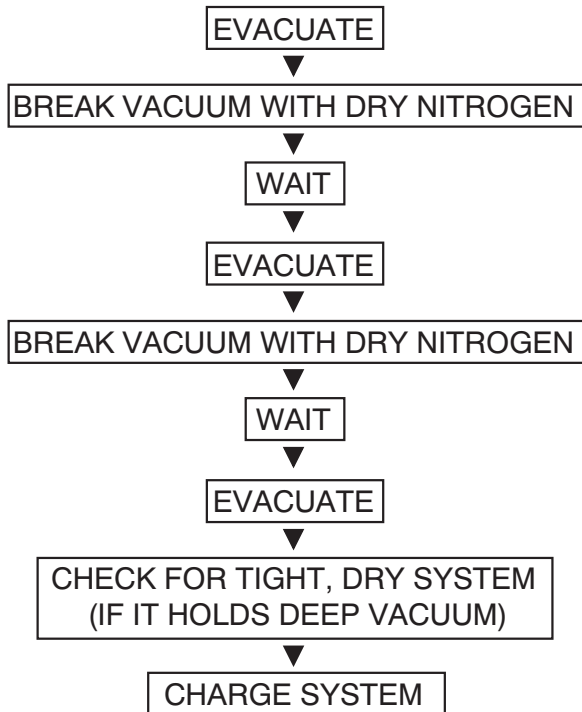

Figure 28 – Triple Evacuation Method

A95425

Check Charge

(See Charging Tables 6 and 7.)

Factory charge amount and desired subcooling are shown on unit rating plate. Charging method is shown on information plate inside unit. To properly check or adjust charge, conditions must be favorable for subcooling charging. Favorable conditions exist when the outdoor temperature is between 70°F and 100°F (21.11°C and 37.78°C), and the indoor temperature is between 70°F and 80°F (21.11°C and 26.67°C). Follow the procedure below:

To check charge allow system to operate in cooling mode at least 15 minutes. If conditions are favorable, check system charge by subcooling method. If any adjustment is necessary, adjust charge slowly and allow system to operate for 15 minutes to stabilize before declaring a properly charged system.

If the indoor temperature is above 80°F (26.67°C), and the outdoor temperature is in the favorable range, adjust system charge and allow the indoor temperature to drop to 80°F (26.67°C) before attempting to check system charge by subcooling method as described above.

If the indoor temperature is below 70°F (21.11°C), or the outdoor temperature is not in the favorable range, the charge level could then be checked at another time when the both indoor and outdoor temperatures are in a more favorable range.

Troubleshooting with SuperHeat

This troubleshooting routine was developed to diagnose cooling problems using superheat in TXV systems. It is effective on heat pumps in cooling mode as well as air conditioners. The system must utilize a TXV as the expansion device in cooling mode.

Basic Diagnostics

NOTE: When checking refrigerant charge and troubleshooting operating systems, the indoor airflow has significant effect on the determination. If you are at this stage, it is assumed you have already checked the subcooling once and believe the charge is correct. From this point, the airflow must be verified prior to proceeding, hence step 1 below.

1. Check or verify proper indoor airflow
 - Indoor air filter
 - Duct dampers and supply registers are open
 - Indoor coil for debris
2. Check subcooling at OD coil and discharge high flow valve
 - Outdoor airflow (debris on coil, etc.)
 - Set the subcooling at value listed on rating plate.
3. Check superheat at suction high flow service valve.
 - If low (< 2°F), proceed to Low SuperHeat section.
 - If between 2 and 20°F/–6.7°C valve is probably operating properly.
 - If operation erratic (hunting), proceed to Hunting Superheat °F Superheat in repetition section.

NOTE: Hunting is when the valve superheat swings more than 10°.

Low Superheat with Normal or Low Suction Pressure

NOTE: Normal or low suction pressure is considered for R-410A: < 135 psig

1. Re-check airflow and then check sensing bulb tightness, orientation on vapor tube and is properly wrapped.
 - Low Superheat with Normal or Low Suction Pressure If OK proceed to Step 2
2. Check superheat at suction high flow service valve and Pseudo Evaporator Superheat.
 - If both are less than 2°F, TXV likely not controlling properly, i.e. stuck open → REPLACE VALVE
 - If superheat is higher than 15°F, proceed to Step 3
3. Perform TXV function check.
 - With system running, place sensing bulb in ice bath for ~1 minute → superheat should increase.
 - If no response, Replace Valve
 - If OK proceed to Step 4
4. Check for even temperature distribution at outlet of each circuit of evaporator
 - If greater than 15°F between circuits, distributor or coil has a restriction.
 - If OK proceed to Step 5

Low Superheat with High Suction Pressure

NOTE: High suction pressure is considered for R-410A: > ~135 psig. Component failure typically causes this condition.

5. Check airflow, sensing bulb tightness, orientation on vapor tube and ensure bulb is properly wrapped.
 - If OK proceed to Step 6
6. Check that compressor is pumping properly

NOTE: Loose Rules of Thumb: Is discharge saturated ~20°F higher than ambient temperature? Is discharge superheat between 15 and 50?

- If OK proceed to Step 7
- 7. Recheck Airflow and Subcooling.
- If OK proceed to Replace Valve

High Superheat with Normal or Low Pressure

NOTE: Normal or low suction pressure is considered: R-410A < 135 psig.

8. Check for restriction in liquid line (kinked line, filter drier restricted, etc.)
 - If OK proceed to Step 9
9. Check for restriction in suction line (kink, restricted suction filter drier etc.)
 - If OK proceed to Step 10
10. Check power element cap tube is not broken
 - If OK proceed to Step 11
11. Check that equalizer tube is not kinked or plugged
 - If OK proceed to Step 12
12. Check that inlet screen is not restricted
 - If OK proceed to Step 13
13. Replace Valve

High Superheat with Normal or High Suction Pressure

NOTE: Normal to High suction pressure is considered for R-410A: > ~110 psig. An application issue or other system component failure typically causes this condition.

14. Check airflow, sensing bulb tightness, orientation on vapor tube and ensure bulb is properly wrapped.
 - If OK proceed to Step 15
15. R-410A Systems: Make sure proper valve is used (Not R-22)
 - If OK proceed to Step 16
16. Check for even temperature distribution at outlet of each circuit of evaporator
 - If OK proceed to Step 17
17. Check for high evaporator load: Return Air Leaks, high indoor wet bulb and/or dry bulb temp, undersized system, etc.
 - If OK proceed to Step 18
18. Check that compressor is pumping properly
 - Loose Rule of Thumb: Is discharge saturated ~20°F higher than ambient temperature? Is discharge superheat between 15°F (-9.4°C) and 50°F (10°C)?

Hunting Superheat

NOTE: Hunting is when the valve superheat swings more than 10°F Superheat in repetition. This is typically an application issue.

19. Check for obvious kinked or pinched distributor (capillary) tubes causing imbalance to the circuiting.
 - If OK proceed to Step 20
20. Check that proper size valve is used per Product Literature.
 - If OK proceed to Step 21
21. Check airflow, sensing bulb tightness, orientation on vapor tube and ensure bulb is properly wrapped.
 - If OK proceed to Step 22
22. Check for even temperature distribution (±5° difference) at outlet of each circuit of evaporator and for even air distribution over all evaporator slabs

- If OK proceed to Step 23
- 23. Move sensing bulb further down suction line.
- If problem not corrected, replace valve

Indoor Airflow and Airflow Adjustments

⚠ WARNING

UNIT OPERATION HAZARD

Failure to follow this caution may result in equipment damage or improper operation.

For cooling operation, the recommended airflow is 350 to 450 cfm for each 12,000 Btuh of rated cooling capacity.

NOTE: Be sure that all supply- and return-air grilles are open, free from obstructions, and adjusted properly.

⚠ WARNING

ELECTRICAL SHOCK HAZARD

Failure to follow this warning could result in personal injury or death.

Disconnect electrical power to the unit and install lockout tag before changing blower speed.

Blower speed tap can be changed by replacing the factory installed blue low speed tap wire (cooling) with the unused black high speed wire in unit control box. The red medium speed wire is factory installed to operate with a call for supplemental electric heat. See unit wiring diagram.

Be sure new airflow meets the range noted above and minimum electric heat CFM, if equipped. Refer to Table 5.

All model sizes are factory wired or rated airflow operation.

Refrigerant Charge

Refrigerant Charge — The refrigerant system is fully charged with R-410A refrigerant and is tested and factory sealed. Amount of refrigerant charge is listed on unit's rating plate. Unit must operate a minimum of 15 minutes before checking charge.

NOTE: Adjustment of the refrigerant charge is not required unless the unit is suspected of not having the proper R-410A charge.

NOTE: Unit sizes 24-48 have fixed orifice refrigerant metering devices, the 60 size has a TXV. There is a different charging procedure for both expansion devices. Refer to the correct procedure for your unit.

NO CHARGE

Use standard evacuating techniques. After evacuating system, weigh in the specified amount of refrigerant (refer to unit's rating plate).

LOW CHARGE COOLING

Fixed Metering Device:

1. Operate unit a minimum of 10 minutes before checking charge.
2. Measure suction pressure by attaching an accurate gauge to compressor suction side service port.
3. Measure suction side temperature by attaching an accurate thermistor type or electronic thermometer to suction line about 10 in. from compressor.
4. Measure outdoor air dry-bulb temperature with thermometer.

5. Measure indoor air (return air) wet-bulb temperature with a sling psychrometer or electronic equivalent.
6. Using Superheat Charging Table (Table 6) find outdoor temperature and indoor air wet-bulb temperature. At this intersection note superheat. Where a dash (--) appears on table do not attempt to charge unit under these conditions or refrigerant slugging may occur. In this situation refrigerant must be evacuated and weighed in. See rating plate for charge quantity.
7. Refer to Required Suction Tube Temp. Table (Table 6). Find superheat temperature located in Step 6 and suction pressure. At this intersection note suction line temperature.
8. If unit has a higher suction line temperature than charted temperature, add refrigerant until charted temperature is reached.
9. If unit has a lower suction line temperature than charted temperature, reclaim refrigerant until charted temperature is reached.
10. If outdoor air temperature or pressure at suction port changes, charge to new suction line temperature indicated on chart.

48-60 Units, TXV

1. Measure Discharge line pressure by attaching a gauge to the service port.
2. Measure the Liquid line temperature by attaching a temperature sensing device to it.
3. Insulate the temperature sensing device so that the Outdoor Ambient doesn't affect the reading.
4. Refer to the required Subcooling in Table 7 based on the model size and the Outdoor Ambient temperature.
5. Interpolate if the Outdoor ambient temperature lies in between the table values.
6. Find the Pressure Value in the table corresponding to the measured Pressure of the Compressor Discharge line.
7. Read across from the Pressure reading to obtain the Liquid line temperature for a required Subcooling.
8. Add Charge if the measured temperature is higher than the table value.
9. Remove charge if the measured temperature is lower than the table value.

Heating Mode

NOTE: When charging is necessary during heating season, charge must be weighed in accordance with unit rating plate.

**Table 5 – Minimum Airflow for Safe Electric Heater Operation
Air Conditioner**

AC Unit Size	Minimum Airflow (CFM)				
	5 kW	7.5 kW	10 kW	15 kW	20 kW
24	600	750	750	X	X
30	600	750	750	X	X
36	600	750	750	1050	X
42	600	750	750	1050	X
48	600	750	750	1050	1400
60	600	750	750	1050	1400

X = Not Approved Combination

Heat Pump

HP Unit Size	Minimum Airflow (CFM)				
	5 kW	7.5 kW	10 kW	15 kW	20 kW
24	750	800	800	X	X
30	750	800	800	X	X
36	750	800	800	1200	X
42	750	800	800	1200	X
48	750	800	800	1200	1700
60	750	800	800	1200	1700

X = Not Approved Combination

Table 6 – Superheat Charging

Sequence of Operation

FAN OPERATION

The FAN switch on the thermostat controls indoor fan operation. When the FAN switch is placed in the ON position, the indoor (evaporator) fan motor (IFM) is energized through the G terminal on the thermostat. The motor's internal logic then provides power to the indoor (evaporator) fan motor (IFM). The IFM will run continuously when the FAN switch is set to ON.

When the FAN switch is set to AUTO, the thermostat deenergizes the IFM (provided there is not a call for cooling). The contacts open and the IFM is deenergized. The IFM will be energized only when there is a call for cooling, in heat pump heating mode or if the unit is equipped with accessory electric heat, the indoor-fan motor will also run while the accessory electric heat is energized.

NOTE: Motors on this product are programmed for 60 second time delay on tap 1 and 30 second time delay on tap 2. There is no time delay on tap 3. The indoor fan will remain ON for the set time delay after G or W2 is de-energized.

COOLING OPERATION

With a call for cooling (Y), the compressor, outdoor fan, and indoor fan start immediately. When the cooling demand is met, Y de-energizes, shutting the compressor, indoor fan and the outdoor fan.

HEATING OPERATION

With a call for heating (Y), the compressor, outdoor fan, and indoor fan start immediately. If Y cannot satisfy the heating demand, the auxiliary or backup heat (W2) energizes. In case of staged heating, W3 is energized if the demand is not met. When heating demand is met, W3, W2 and Y sequentially de-energize shutting the compressor, indoor fan and the outdoor fan.

CONTINUOUS FAN

With the continuous indoor fan option selected on the thermostat, G is continuously energized. The continuous fan speed will be the same as the cooling fan speed.

DEFROST

Defrost board (DB) is a time and temperature control, which includes a field-selectable time period between checks for defrost (30, 60, 90 and 120 minutes). The time period is factory-set at 60 minutes and should only be adjusted by a trained service person. Electronic timer and defrost cycle start only when contactor is energized and defrost thermostat (DFT) is closed.

Defrost mode is identical to Cooling mode. The outdoor fan motor stops because of "OF1" and "OF2" contacts opening on the defrost board, a bank of optional electric heat turns on to warm air supplying the conditioned space.

ELECTRIC RESISTANCE HEATING

If accessory electric heaters are installed, on a call for "Emergency Heat" the thermostat energizes W which energizes the heater relay and in turn energizes the electric heaters. The IFM is energized which starts the indoor-fan motor. If the heaters are staged, W2 is energized when the second stage of heating is required. When the need for heating is satisfied, the heater and IFM are de-energized.

ECM Fan Motor Troubleshooting

Caution – Do not disconnect motor plugs under load.

- Check the high-voltage supply to motor. The ECM fan motor will always have high voltage to the motor even when the motor is off. The 24 volt signal cycles the motor on and off. The motor can accept more than one 24 volt control signal to the different motor taps without damaging it. The

motor will default to the highest speed tap that see a 24 volt signal.

Fan won't run...

- Cycle power off to the unit. Disconnect the two plugs going into the motor. One plug is the high voltage supply and the other is the low voltage control.
- Cycle power back on and measure the high voltage supply plug to determine if there is voltage at plug. If there is no voltage at plug, determine if there is power to the unit. The easiest place to measure the voltage is on the line side of the contactor. If there is voltage at the contactor and no voltage at the plug, cycle the power back off and inspect the wiring harness and plug for loose or broken connections.
- Replace the wiring harness and plug, if it is found to be defective.
- If there is power at the high voltage plug, check the low voltage control signal.
- With the power on to the unit, verify that there is 24volts between R and C in the low voltage control box. If there is not 24 volts at R and C check the inline 3 amp fuse. If the fuse is blown, check for shorted, bare or chaffed wires before installing another fuse in the holder. If the fuse is good make sure there is line voltage on the primary side of the transformer. Then check the secondary side of the transformer. If there is line voltage on the transformer primary and no voltage on the secondary; replace the transformer.
- If there is 24volts between R and C, jump R and G together in the low voltage control box. Check to see if there is a 24 volt signal at pins 1, 2 or 3 referenced to common (ground) at the motor's low voltage plug. If there is no voltage between common and one of the pins, trace the wires back to the low voltage control box.
- If there is power at the high voltage plug, voltage at pins 1, 2 or 3 on the low voltage plug, the connections are good between the plugs and motor and the motor is not running: replace the motor.

Two 24 volt signal wires will be connected from the thermostat to the low voltage control plug. One wire (signal) will be for constant fan (cooling) speed and the other will be for electric heat.

If there is an intermittent motor operation issue, check the 1000 ohm resistor between the green "G" wire and the brown "C" wire in the unit's wiring harness. (See unit's wiring diagram.) The resistor could be blown (open). This resistor is in line with the fan motor to provide a load for the thermostat's triacs, or relay.

Time Delays

The unit/system time delays include:

- The air conditioning or heat pump units do not have any built in time delays to start the cooling or heating cycle. Most residential thermostats have an electronic safety start feature built into the software to prevent compressor short cycling.
- The indoor fan motor (ECM) has a built in fan off delays on the first two taps of the motor. The third motor tap will shut off immediately after the 24v signal is gone. See the following for details:

Tap 1 – 60 second off delay

Tap 2 – 30 second off delay

Tap 3 – 0 second off delay

- The only other timing feature in the heat pump units are built into the defrost board. See defrost board sequence for more details on defrost time delays and setups.

Pressure Switches

The R-410A air conditioner contains one pressure switch to prevent system operation if the pressures get excessively high. The high pressure switch opens at 650 psig and closes at 420 psig. The pressure switch setting is considerably higher than on comparably sized R-22 units. The high pressure switch can be identified by their pink stripe on the switch's electrical wires.

The R-410A heat pump contains a loss of charge switch in the liquid line which opens at 20 psig and closes at 45 psig. See troubleshooting section for sequence when a pressure switch trip occurs.

Accumulator, Reversing Valve (RVS)

The R-410A heat pumps have a specifically designed reversing valve, for R-410A application and an accumulator for storing excess liquid refrigerant during the heating mode to prevent damaging flood-back.

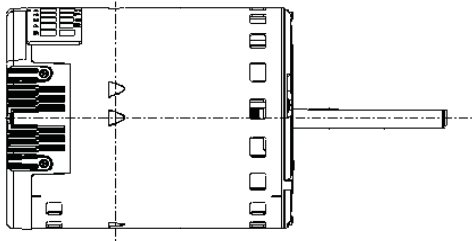

Figure 29 – ECM Motor

A10170

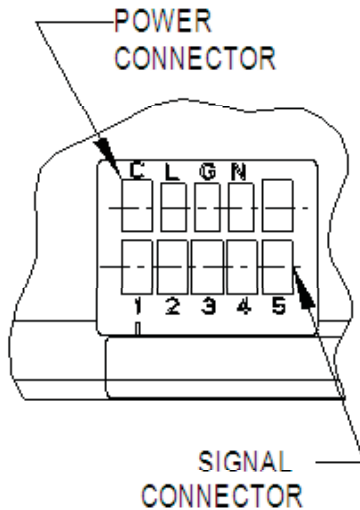

Figure 30 – ECM Module Plug

A10169

Control Box

Contactors, Capacitor and Board

Removal of the front, right compressor/control panel will expose most of the unit's components. Both the air conditioner and heat pump control boxes will be in the upper right corner of the unit. There will be a contactor that cycles components off and on. The capacitor will assist the outdoor fan and compressor to operate. The heat pump models will have a circuit board to control the defrost cycle.

Always replace these devices with the Factory Approved Components.

Incoming Power

Incoming power is attached to the two power wire stripped leads. A ground lug is also provided. Unit should always be grounded through the ground lug to the unit disconnect and from the disconnect to the electrical fuse box. Failure to do so can cause serious injury or death.

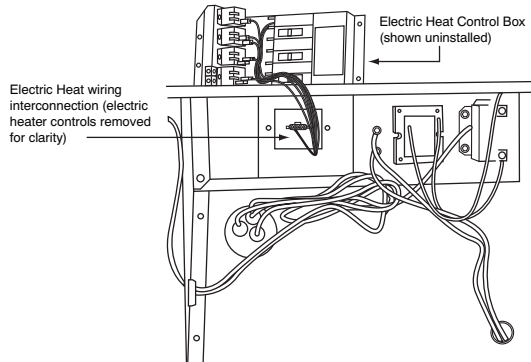

A10030

Air Conditioning Control Box Wiring

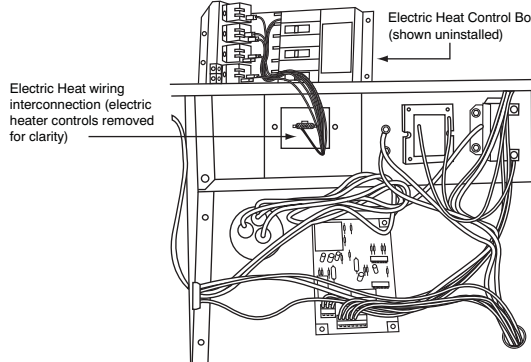

A10031

Heat Pump Control Box Wiring
Figure 31 – Control Box Wiring

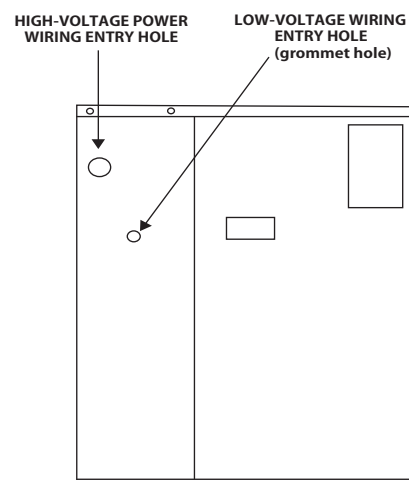

A08407

Figure 32 – Unit Electrical Connection

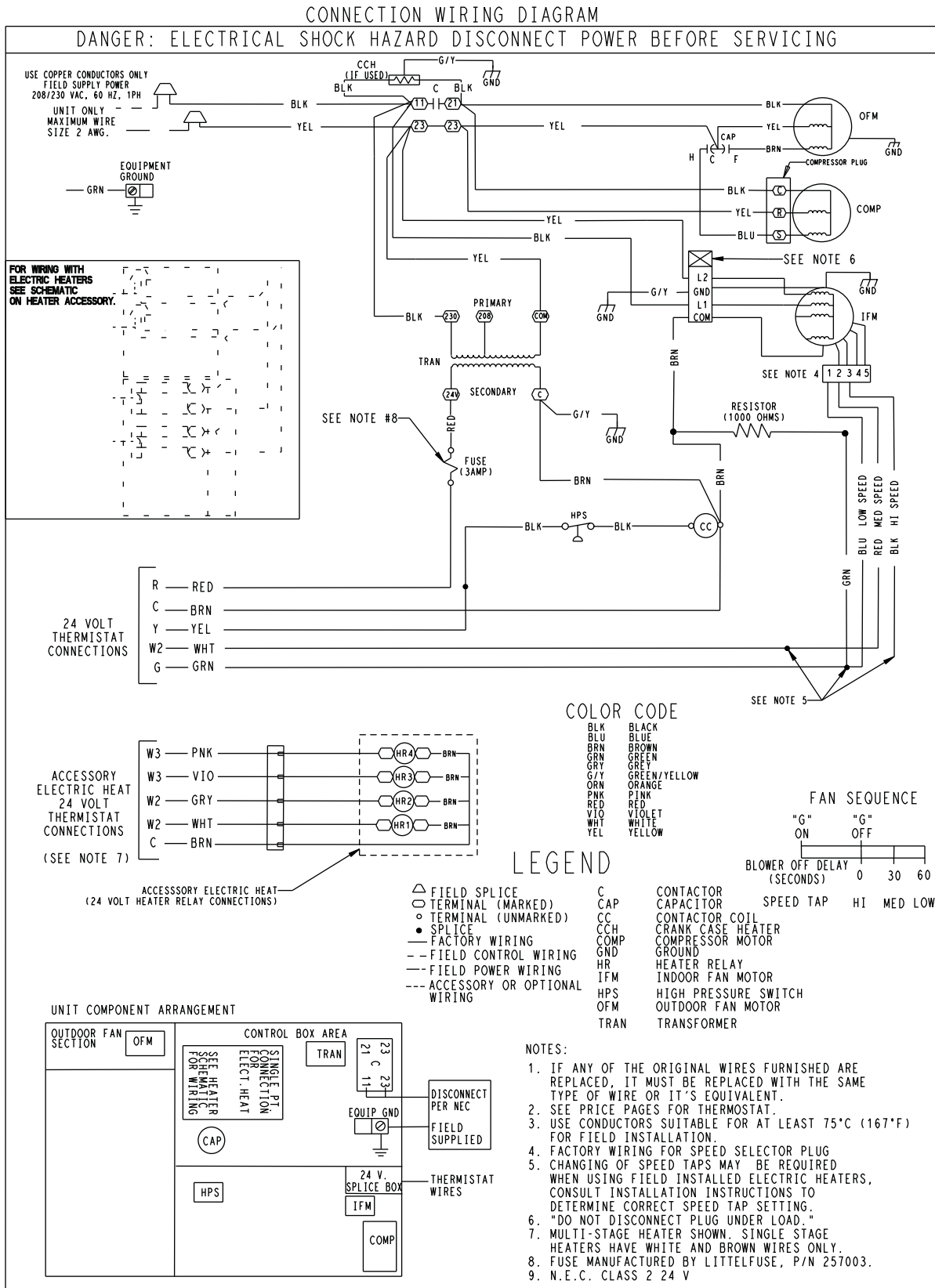
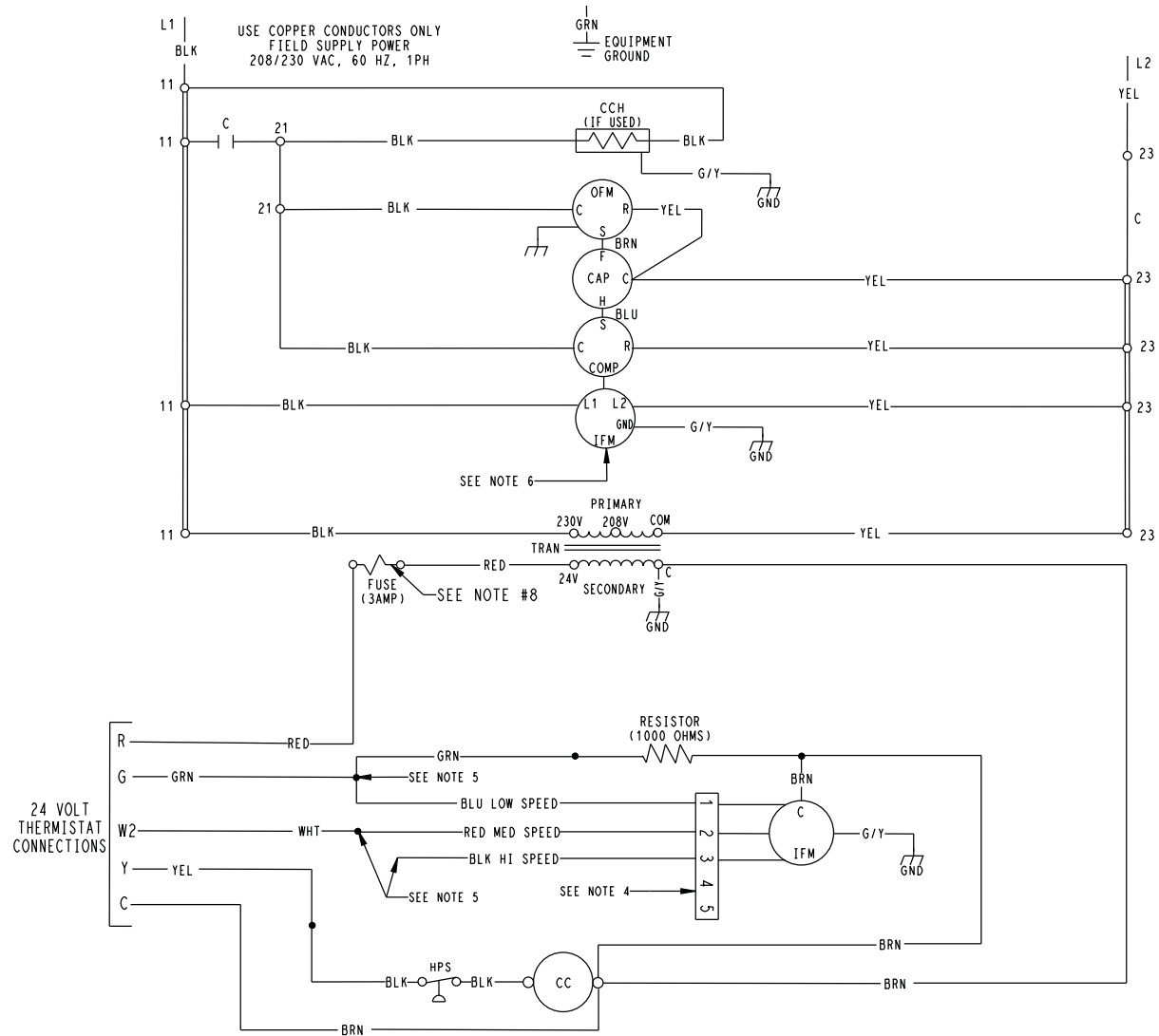

Figure 33 – Typical Air Conditioning Single-Phase Unit Connection Electrical Diagram

A14542

LADDER WIRING DIAGRAM

DANGER: ELECTRICAL SHOCK HAZARD DISCONNECT POWER BEFORE SERVICING



50ZP500775 B

Figure 34 - Typical Air Conditioning Single-Phase Unit Ladder Electrical Diagram

A14543

CONNECTION WIRING DIAGRAM

DANGER: ELECTRICAL SHOCK HAZARD DISCONNECT POWER BEFORE SERVICING

USE COPPER CONDUCTORS ONLY
FIELD SUPPLY POWER
208/230 VAC, 60 HZ, 1PH

UNIT ONLY
MAXIMUM WIRE
SIZE 2 AWG.

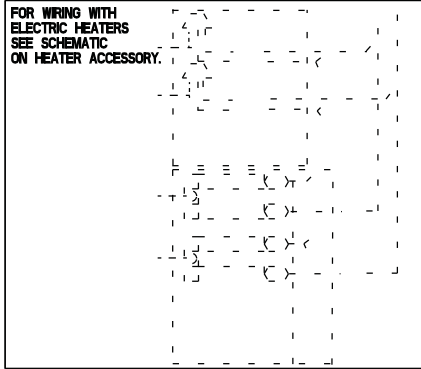
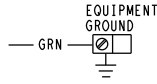

24 VOLT THERMISTAT CONNECTIONS
R — RED
O — ORN
W2 — WHT
Y — YEL
C — BRN
G — GRN

ACCESSORY ELECTRIC HEAT 24 VOLT THERMISTAT CONNECTIONS (SEE NOTE 7)
W3 — PNK
W3 — VIO
W2 — GRY
W2 — WHT
C — BRN

ACCESSORY ELECTRIC HEAT (24 VOLT HEATER RELAY CONNECTIONS)

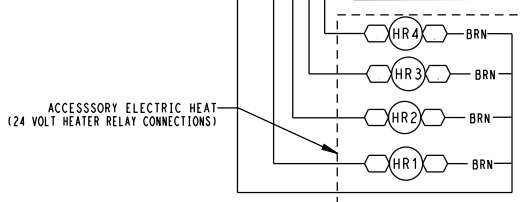

UNIT COMPONENT ARRANGEMENT

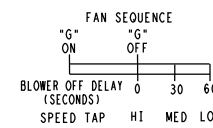
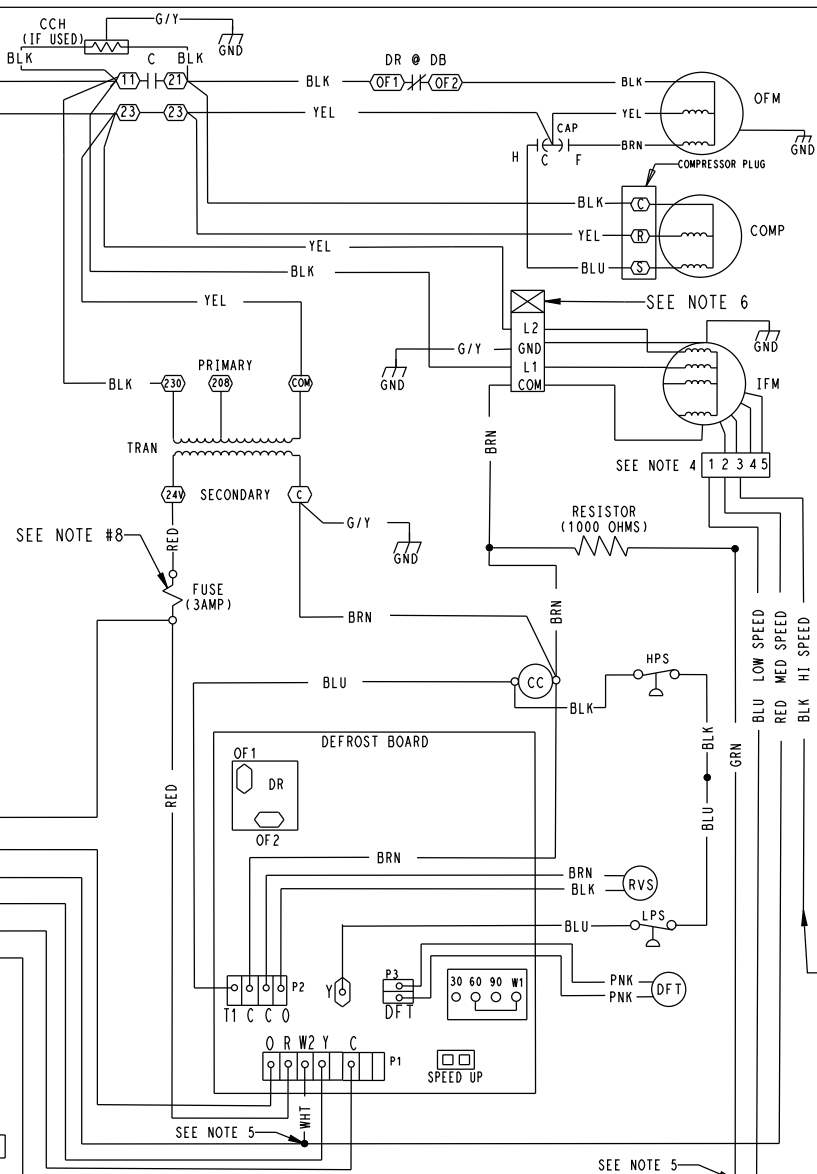
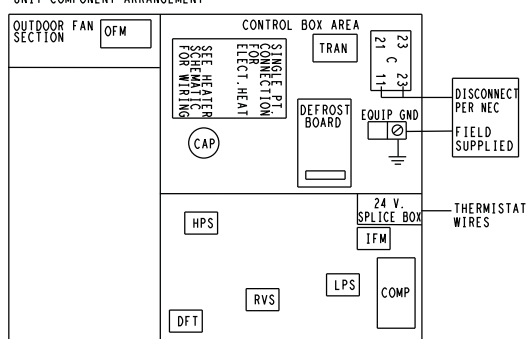

COLOR CODE

- BLK BLACK
- BLU BLUE
- BRN BROWN
- GRN GREEN
- GRY GREY
- G/Y GREEN/YELLOW
- ORN ORANGE
- PNK PINK
- RED RED
- VIO VIOLET
- WHT WHITE
- YEL YELLOW

LEGEND

- FIELD SPlice
- TERMINAL (MARKED)
- TERMINAL (UNMARKED)
- SPlice
- FACTORY WIRING
- - - FIELD CONTROL WIRING
- - - FIELD POWER WIRING
- - - ACCESSORY OR OPTIONAL WIRING
- C CAPACITOR
- CC CONTACTOR COIL
- CCH CRANK CASE HEATER
- COMP COMPRESSOR MOTOR
- DB DEFROST BOARD
- DR DEFROST THERMOSTAT
- DR DEFROST RELAY
- GND GROUND
- HR HEATER RELAY
- IFM INDOOR FAN MOTOR
- LPS LOW PRESSURE SWITCH
- HPS HIGH PRESSURE SWITCH
- OFM OUTDOOR FAN MOTOR
- PLUG PLUG
- RVS REVERSING VALVE SOLENOID
- TRAN TRANSFORMER

DEFROST TIMING SELECTION

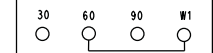

FIELD SELECTABLE OPTIONS FOR TIME PERIOD BETWEEN DEFROST CYCLES (MINUTES)
FACTORY DEFROST SETTING IS 60 MIN.

SPEED UP JUMPED SPEED UP PINS (USE METAL OBJECT) UP FIELD SPEED-UP CYCLE

1. DFT MUST BE CLOSED TO INITIATE DEFROST CYCLE. IF NECESSARY, REMOVE DFT CONNECTION BEFORE PLACING JUMPER ACCROSS DFT PINS.
2. AT THE SAME TIME DFT CLOSED, JUMPER "SPEED UP" PINS WITH SMALL SCREW DRIVER UNTIL DEFROST IS INITIATED. THEN REMOVE SCREW DRIVER.
3. SHORTED "SPEED UP" PINS WILL SPEED UP TIMER BY A FACTOR OF 256.

NOTES:

1. IF ANY OF THE ORIGINAL WIRES FURNISHED ARE REPLACED, IT MUST BE REPLACED WITH THE SAME TYPE OF WIRE OR IT'S EQUIVALENT.
2. SEE PRICE PAGES FOR THERMOSTAT.
3. USE CONDUCTORS SUITABLE FOR AT LEAST 75°C (167°F) FOR FIELD INSTALLATION.
4. FACTORY WIRING FOR SPEED SELECTOR PLUG
5. CHANGING OF SPEED TAPS MAY BE REQUIRED WHEN USING FIELD INSTALLED ELECTRIC HEATERS. CONSULT INSTALLATION INSTRUCTIONS TO DETERMINE CORRECT SPEED TAP SETTING.
6. "DO NOT DISCONNECT PLUG UNDER LOAD."
7. MULTI-STAGE HEATER SHOWN. SINGLE STAGE HEATERS HAVE WHITE AND BROWN WIRES ONLY.
8. FUSE MANUFACTURED BY LITTELFUSE, P/N 257003.
9. N.E.C. CLASS 2 24 V

Figure 35 – Typical Heat Pump Unit Connection Electrical Diagram

A14544

CARE AND MAINTENANCE

To assure high performance and minimize possible equipment malfunction, it is essential that maintenance be performed periodically on this equipment. The frequency with which maintenance is performed is dependent on such factors as hours of operation, geographic location, and local environmental conditions.

⚠ WARNING

ELECTRICAL SHOCK HAZARD

Failure to follow this warning could result in equipment damage or death.

Disconnect all electrical power to unit before performing any maintenance or service on outdoor unit. Remember to disconnect power supply to air handler as this unit supplies low-voltage power to the outdoor unit. Lock out and tag switch with suitable warning label.

The minimum maintenance that should be performed on this equipment is as follows:

1. Check outdoor coil for cleanliness each heating and cooling season and clean as necessary.
2. Check fan motor and blade for cleanliness each month during cooling season and clean as necessary.
3. Check electrical connections for tightness and controls for proper operation each cooling season and service as necessary.

⚠ CAUTION

UNIT DAMAGE HAZARD

Failure to follow this caution may result in equipment damage or improper operation.

Because of possible damage to the equipment or personal injury, maintenance should be performed by qualified personnel only.

Desert and Seacoast Locations

Special consideration must be given to installation and maintenance of condensing units installed in coastal or desert locations. This is because salt and alkali content of sand adheres to aluminum fins of coil and can cause premature coil failure due to corrosion.

Preventive measures can be taken during installations, such as:

1. Locate unit on side of structure opposite prevailing winds.
2. Install unit where drifting sand cannot pile up against coil.

Maintenance in desert and seacoast locations:

1. Frequent inspection of coil and basepan especially after storms and/or high winds.
2. Clean coil by flushing out sand from between coil fins and out of basepan as frequently as inspection determines necessary.
3. In off season, cover with covering that allows air to circulate through but prevents sand from sifting in (such as canvas material). Do not use plastic as plastic will hold moisture possibly causing corrosion.

Cleaning Coil

1. Remove side panel. (See Remove Side Panel in Cabinet section of this manual.)

⚠ CAUTION

UNIT DAMAGE HAZARD

Failure to follow this caution may result in equipment damage or improper operation.

Coil fin damage can result in higher operating costs or compressor damage. Do not use flame, high-pressure water, steam, volatile or corrosive cleaners on fins or tubing.

2. Clean coil using vacuum cleaner and its crevice tool. Move crevice tool vertically, close to area being cleaned, making sure tool touches only dirt on fins and not fins. To prevent fin damage, do not scrub fins with tool or move tool horizontally against fins.
3. If oil deposits are present, spray coil with ordinary household detergent. Wait 10 minutes, and proceed to next step.
4. Using garden hose, spray coil vertically downward with constant stream of water at moderate pressure. Keep nozzle at a 15- to 20° angle, about 3 in. from coil face and 18 in. from tube. Spray so debris is washed out of coil and basepan.
5. Reinstall side panel.
6. Reconnect electrical power and check for proper operation.

Cleaning Outdoor Fan Motor and Blade

1. Remove grille, fan motor and blade. Be careful not to bend or dent fan blade.
2. Clean motor and blade with soft brush or cloth. Be careful not to disturb balance weights on fan blade.
3. Check fan blade setscrew for tightness.
4. Reinstall fan motor and blade to grille and check for alignment.
5. Reinstall grille and position blade.
6. Reconnect electrical power and check for proper operation.

Electrical Controls and Wiring

1. Disconnect power to unit.
2. Check all electrical connections for tightness. Tighten all screws on electrical connections. If any connections appear to be burned or smoky, disassemble the connection, clean all parts and stripped wires, and reassemble. Use a new connector if old one is burned or corroded, and crimp tightly.
3. Reconnect electrical power to unit and observe unit through 1 complete operating cycle.
4. If there are any discrepancies in operating cycle, troubleshoot to find cause and correct.

Refrigerant Circuit

1. Check refrigerant charge using the superheat method, and if low on charge, check unit for leaks using an electronic leak detector.
2. If any leaks are found, remove and reclaim or isolate charge (pumpdown) if applicable. Make necessary repairs.
3. Evacuate, recharge, and observe unit through 1 complete operating cycle.

Final Check–Out

After the unit has been operating, the following items should be checked.

1. Check that unit operational noise is not excessive due to vibration of component, tubing, panels, etc. If present, isolate problem and correct.
2. Check to be sure caps are installed on high flow valves and are tight.
3. Check to be sure tools, loose parts, and debris are removed from unit.
4. Check to be sure all panels and screws are in place and tight.

R–410A REFRIGERANT QUICK REFERENCE GUIDE

- R–410A refrigerant operates at 50–70 percent higher pressures than R–22. Be sure that servicing equipment and replacement components are designed to operate with R–410A refrigerant.
- R–410A refrigerant cylinders are rose colored.
- Recovery cylinder service pressure rating must be 400 psig, DOT 4BA400 or DOT BW400.
- R–410A refrigerant systems should be charged with liquid refrigerant. Use a commercial type metering device in the manifold hose when charging into suction line with compressor operating
- Manifold sets should be 700 psig high side and 180 psig low side with 550 psig low–side retard.
- Use hoses with 700 psig service pressure rating.
- Leak detectors should be designed to detect HFC refrigerant.
- R–410A refrigerant, as with other HFCs, is only compatible with POE or PVE oils.
- Vacuum pumps will not remove moisture from oil.
- Do not use liquid–line filter driers with rated working pressures less than 600 psig.
- Do not leave R–410A refrigerant suction line filter driers in line longer than 72 hours.
- Do not install a suction–line filter drier in liquid line.
- POE and PVE oils absorb moisture rapidly. Do not expose oil to atmosphere.
- POE and PVE oils may cause damage to certain plastics and roofing materials.
- Wrap all filter driers with wet cloth when brazing.
- A factory approved liquid–line filter drier is required on every unit.
- Do NOT use an R–22 TXV.
- Never open system to atmosphere while it is under a vacuum.
- When system must be opened for service, recover refrigerant, evacuate then break vacuum with dry nitrogen and replace filter driers. Evacuate to 500 microns prior to recharging.
- Do not vent R–410A refrigerant into the atmosphere.
- Observe all **warnings**, **cautions**, and **bold** text.

Table 8 – Pressure vs. Temperature Chart – R-410A Refrigerant

PSIG	°F	°C	PSIG	°F	°C	PSIG	°F	°C	PSIG	°F	°C	PSIG	°F	°C	PSIG	°F	°C
12	-37.7	-38.7	114	37.8	3.2	216	74.3	23.5	318	100.2	37.9	420	120.7	49.3	522	137.6	58.7
14	-34.7	-37.0	116	38.7	3.7	218	74.9	23.8	320	100.7	38.2	422	121.0	49.4	524	137.9	58.8
16	-32.0	-35.6	118	39.5	4.2	220	75.5	24.2	322	101.1	37.4	424	121.4	47.7	526	138.3	59.1
18	-29.4	-34.1	120	40.5	4.7	222	76.1	24.5	324	101.6	37.8	426	121.7	49.8	528	138.6	59.2
20	-26.9	-32.7	122	41.3	5.2	224	76.7	24.8	326	102.0	38.9	428	122.1	50.1	530	138.9	59.4
22	-24.5	-31.3	124	42.2	5.7	226	77.2	25.1	328	102.4	39.1	430	122.5	50.3	532	139.2	59.6
24	-22.2	-30.1	126	43.0	6.1	228	77.8	25.4	330	102.9	39.4	432	122.8	50.4	534	139.5	59.7
26	-20.0	-28.9	128	43.8	6.6	230	78.4	25.6	332	103.3	39.6	434	123.2	50.7	536	139.8	59.9
28	-17.9	-28.7	130	44.7	7.1	232	78.9	26.1	334	103.7	39.8	436	123.5	50.8	538	140.1	60.1
30	-15.8	-26.6	132	45.5	7.5	234	79.5	26.4	336	104.2	40.1	438	123.9	51.1	540	140.4	60.2
32	-13.8	-25.4	134	46.3	7.9	236	80.0	26.7	338	104.6	40.3	440	124.2	51.2	544	141.0	60.6
34	-11.9	-24.4	136	47.1	8.4	238	80.6	27.0	340	105.1	40.6	442	124.6	51.4	548	141.6	60.9
36	-10.1	-23.4	138	47.9	8.8	240	81.1	27.3	342	105.4	40.8	444	124.9	51.6	552	142.1	61.2
38	-8.3	-22.4	140	48.7	9.3	242	81.6	27.6	344	105.8	41.0	446	125.3	51.8	556	142.7	61.5
40	-6.5	-21.4	142	49.5	9.7	244	82.2	27.9	346	106.3	41.3	448	125.6	52.0	560	143.3	61.8
42	-4.5	-20.3	144	50.3	10.2	246	82.7	28.2	348	106.6	41.4	450	126.0	52.2	564	143.9	62.2
44	-3.2	-19.6	146	51.1	10.6	248	83.3	28.5	350	107.1	41.7	452	126.3	52.4	568	144.5	62.5
46	-1.6	-18.7	148	51.8	11.0	250	83.8	28.8	352	107.5	41.9	454	126.6	52.6	572	145.0	62.8
48	0.0	-17.8	150	52.5	11.4	252	84.3	29.1	354	107.9	42.2	456	127.0	52.8	576	145.6	63.1
50	1.5	-16.9	152	53.3	11.8	254	84.8	29.3	356	108.3	42.4	458	127.3	52.9	580	146.2	63.4
52	3.0	-16.1	154	54.0	12.2	256	85.4	29.7	358	108.8	42.7	460	127.7	53.2	584	146.7	63.7
54	4.5	-15.3	156	54.8	12.7	258	85.9	29.9	360	109.2	42.9	462	128.0	53.3	588	147.3	64.1
56	5.9	-14.5	158	55.5	13.1	260	86.4	30.2	362	109.6	43.1	464	128.3	53.5	592	147.9	64.4
58	7.3	-13.7	160	56.2	13.4	262	86.9	30.5	364	110.0	43.3	466	128.7	53.7	596	148.4	64.7
60	8.6	-13.0	162	57.0	13.9	264	87.4	30.8	366	110.4	43.6	468	129.0	53.9	600	149.0	65.0
62	10.0	-12.2	164	57.7	14.3	266	87.9	31.1	368	110.8	43.8	470	129.3	54.1	604	149.5	65.3
64	11.3	-11.5	166	58.4	14.7	268	88.4	31.3	370	111.2	44.0	472	129.7	53.2	608	150.1	65.6
66	12.6	-10.8	168	59.0	15.0	270	88.9	31.6	372	111.6	44.2	474	130.0	54.4	612	150.6	65.9
68	13.8	-10.1	170	59.8	15.4	272	89.4	31.9	374	112.0	44.4	476	130.3	54.6	616	151.2	66.2
70	15.1	-9.4	172	60.5	15.8	274	89.9	32.2	376	112.4	44.7	478	130.7	54.8	620	151.7	66.5
72	16.3	-8.7	174	61.1	16.2	276	90.4	32.4	378	112.6	44.8	480	131.0	55.0	624	152.3	66.8
74	17.5	-8.1	176	61.8	16.6	278	90.9	32.7	380	113.1	45.1	482	131.3	55.2	628	152.8	67.1
76	18.7	-7.4	178	62.5	16.9	280	91.4	33.0	382	113.5	45.3	484	131.6	55.3	632	153.4	67.4
78	19.8	-6.8	180	63.1	17.3	282	91.9	33.3	384	113.9	45.5	486	132.0	55.6	636	153.9	67.7
80	21.0	-6.1	182	63.8	17.7	284	92.4	33.6	386	114.3	45.7	488	132.3	55.7	640	154.5	68.1
82	22.1	-5.5	184	64.5	18.1	286	92.8	33.8	388	114.7	45.9	490	132.6	55.9	644	155.0	68.3
84	23.2	-4.9	186	65.1	18.4	288	93.3	34.1	390	115.0	46.1	492	132.9	56.1	648	155.5	68.6
86	24.3	-4.3	188	65.8	18.8	290	93.8	34.3	392	115.5	46.4	494	133.3	56.3	652	156.1	68.9
88	25.4	-3.7	190	66.4	19.1	292	94.3	34.6	394	115.8	46.6	496	133.6	56.4	656	156.6	69.2
90	26.4	-3.1	192	67.0	19.4	294	94.8	34.9	396	116.2	46.8	498	133.9	56.6	660	157.1	69.5
92	27.4	-2.6	194	67.7	19.8	296	95.2	35.1	398	116.6	47.0	500	134.0	56.7	664	157.7	69.8
94	28.5	-1.9	196	68.3	20.2	298	95.7	35.4	400	117.0	47.2	502	134.5	56.9	668	158.2	70.1
96	29.5	-1.4	198	68.9	20.5	300	96.2	35.7	402	117.3	47.4	504	134.8	57.1	672	158.7	70.4
98	30.5	-0.8	200	69.5	20.8	302	96.6	35.9	404	117.7	47.6	506	135.2	57.3	676	159.2	70.7
100	31.2	-0.4	202	70.1	21.2	304	97.1	36.2	406	118.1	47.8	508	135.5	57.5	680	159.8	71.0
102	32.2	0.1	204	70.7	21.5	306	97.5	36.4	408	118.5	47.1	510	135.8	57.7	684	160.3	71.3
104	33.2	0.7	206	71.4	21.9	308	98.0	36.7	410	118.8	48.2	512	136.1	57.8	688	160.8	71.6
106	34.1	1.2	208	72.0	22.2	310	98.4	36.9	412	119.2	48.4	514	136.4	58.0	692	161.3	71.8
108	35.1	1.7	210	72.6	22.6	312	98.9	37.2	414	119.6	47.7	516	136.7	57.7	696	161.8	72.1
110	35.5	1.9	212	73.2	22.9	314	99.3	37.4	416	119.9	48.8	518	137.0	58.3			
112	36.9	2.7	214	73.8	23.2	316	99.7	37.6	418	120.3	49.1	520	137.3	58.5			

AIR CONDITIONER TROUBLESHOOTING CHART

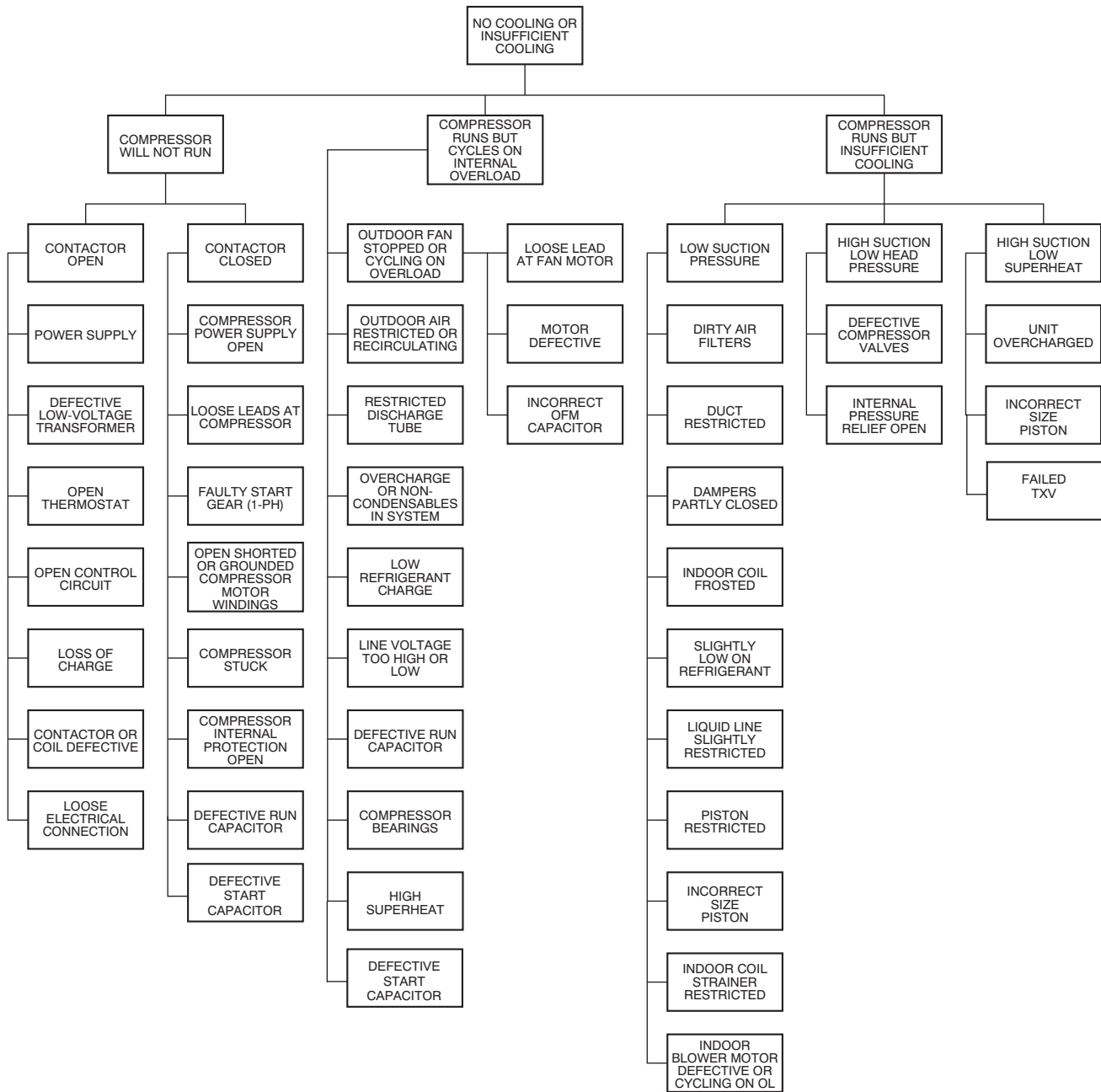

Figure 37 – Air Conditioner Troubleshooting Chart

A90208

HEAT PUMP TROUBLESHOOTING HEATING CYCLE

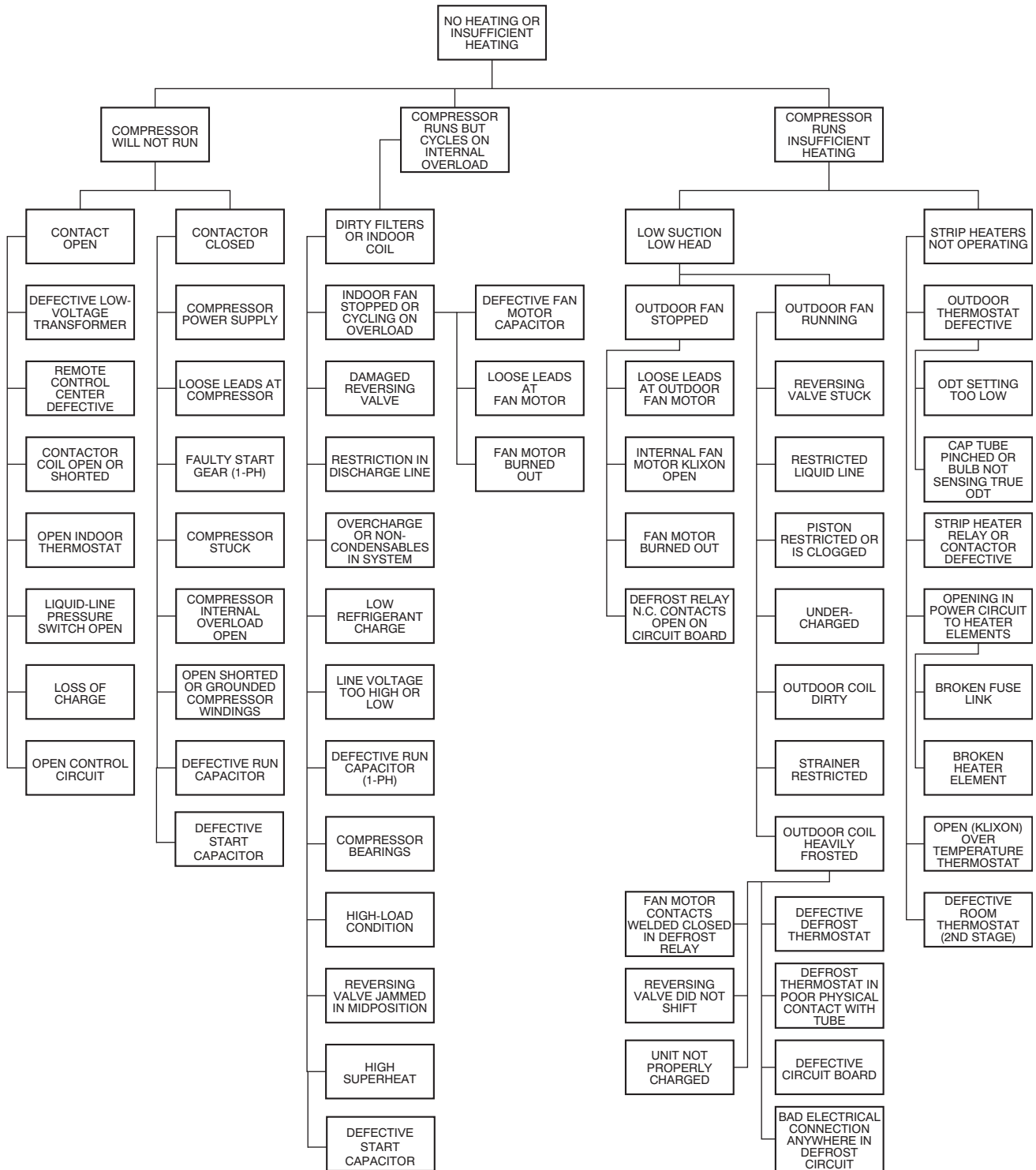
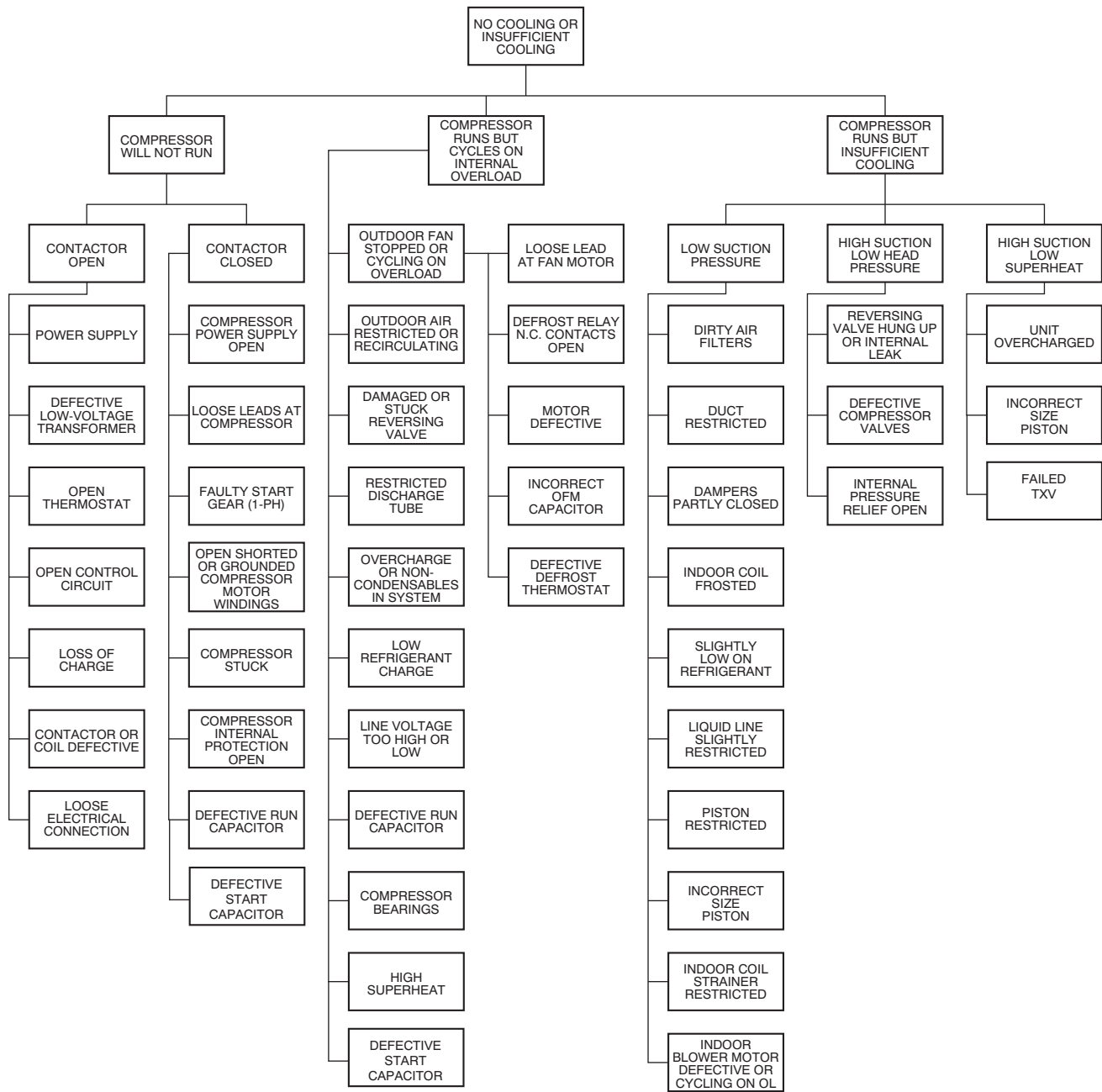

Figure 38 – Heat Pump Troubleshooting – Heating Cycle

A90206

HEAT PUMP TROUBLESHOOTING COOLING CYCLE



A90207

Figure 39 – Heat Pump Troubleshooting – Cooling Cycle

INDEX OF TABLES

DESCRIPTION	PAGE
Required Field-Installed Accessories for Air Conditioners & Heat Pumps Table	2
Defrost Control Speed-Up Timing Sequence Table	14
Air Conditioner & Heat Pump Compressor Information Table	21
Piston/TXV Table	23
Minimum Airflow for Safe Electric Heater Operation Table	29
Superheat Charging Table	29
Required Subcooling Table	30
Pressure vs Temperature Chart Table	39