

INSTALLATION INSTRUCTIONS

R-410A, 50 Hz Split System Heat Pump

Product Family: R4HE

These instructions must be read and understood completely before attempting installation.

Safety Labeling and Signal Words

DANGER, WARNING, CAUTION, and NOTE

The signal words **DANGER**, **WARNING**, **CAUTION**, and **NOTE** are used to identify levels of hazard seriousness. The signal word **DANGER** is only used on product labels to signify an immediate hazard. The signal words **WARNING**, **CAUTION**, and **NOTE** will be used on product labels and throughout this manual and other manuals that may apply to the product.

DANGER – Immediate hazards which **will** result in severe personal injury or death.

WARNING – Hazards or unsafe practices which **could** result in severe personal injury or death.

CAUTION – Hazards or unsafe practices which **may** result in minor personal injury or product or property damage.

NOTE – Used to highlight suggestions which **will** result in enhanced installation, reliability, or operation.

Signal Words in Manuals

The signal word **WARNING** is used throughout this manual in the following manner:



The signal word **CAUTION** is used throughout this manual in the following manner:



Signal Words on Product Labeling

Signal words are used in combination with colors and/or pictures on product labels.



TABLE OF CONTENTS

Safety Considerations	2
Installation	2
Location	2
Clearances	3
Refrigeration System	3
Electrical Connections	6
Start-up Procedure	7
Sequence of Operation	7
Refrigerant Charge	8
Maintenance	9
R-410A Quick Reference Guide	10



DEATH, PERSONAL INJURY, AND/OR PROPERTY DAMAGE HAZARD

Failure to carefully read and follow this warning could result in equipment malfunction, property damage, personal injury and/or death.

Installation or repairs made by unqualified persons could result in equipment malfunction, property damage, personal injury and/or death.

The information contained in this manual is intended for use by a qualified service technician familiar with safety procedures and equipped with the proper tools and test instruments.

Installation must conform with local building codes and with the National Electrical Code NFPA70 current edition or Canadian Electrical Code Part 1 CSA C.22.1.

SAFETY CONSIDERATIONS

Improper installation, adjustment, alteration, service, maintenance, or use can cause explosion, fire, electrical shock, or other conditions which may cause death, personal injury, or property damage. Consult a qualified installer,

service agency, or your distributor or branch for information or assistance. The qualified installer or agency must use factory–authorized kits or accessories when modifying this product. Refer to the individual instructions packaged with the kits or accessories when installing.

Follow all safety codes. Wear safety glasses, protective clothing, and work gloves. Use quenching cloth for brazing operations. Have fire extinguisher available. Read these instructions thoroughly and follow all warnings or cautions included in literature and attached to the unit. Consult local building codes and current editions of the National Electrical Code (NEC) NFPA 70. In Canada, refer to current editions of the Canadian electrical code CSA 22.1.

Recognize safety information. This is the safety–alert symbol

⚠ When you see this symbol on the unit and in instructions or manuals, be alert to the potential for personal injury. Understand these signal words; DANGER, WARNING, and CAUTION. These words are used with the safety–alert symbol. DANGER identifies the most serious hazards which will result in severe personal injury or death. WARNING signifies hazards which could result in personal injury or death. CAUTION is used to identify unsafe practices which would result in minor personal injury or product and property damage. NOTE is used to highlight suggestions which will result in enhanced installation, reliability, or operation.

⚠ CAUTION

CUT HAZARD

Failure to follow this caution may result in property damage.

Sheet metal parts may have sharp edges or burrs. Use care and wear appropriate protective clothing and gloves when handling parts.

⚠ WARNING

ELECTRICAL SHOCK HAZARD

Failure to follow this warning could result in personal injury or death.

Before installing, modifying, or servicing system, main electrical disconnect switch must be in the OFF position. There may be more than 1 disconnect switch. Lock out and tag switch with a suitable warning label.

⚠ WARNING

PROPERTY DAMAGE HAZARD

Failure to follow this warning could result in property damage.

R-410A refrigerant systems operate at higher pressures than standard R-22 systems. Do not use R-22 service equipment or components on R-410A refrigerant equipment.

INSTALLATION

NOTE: In some cases noise in the living area has been traced to gas pulsations from improper installation of equipment.

1. Locate unit away from windows, patios, decks, and so forth, where unit operation sound may disturb customer.
2. Insure that vapor– and liquid–tube diameters are appropriate to capacity of unit.
3. Run refrigerant tubes as directly as possible by avoiding unnecessary turns and bends.
4. Leave some slack between structure and unit to absorb vibration.
5. When passing refrigerant tubes through the wall, seal opening with RTV or other pliable silicon–based caulk. (See Fig. 1.)
6. Avoid direct tubing contact with water pipes, duct work, floor joists, wall studs, floors, and walls.
7. Do not suspend refrigerant tubing from joists and studs with a rigid wire or strap that comes in direct contact with tubing. (See Fig. 1.)
8. Ensure that tubing insulation is pliable and completely surrounds vapor tube.
9. When necessary, use hanger straps which are 1 in. (25mm) wide and conform to shape of tubing insulation. (See Fig. 1.)
10. Isolate hanger straps from insulation by using metal sleeves bent to conform to shape of insulation.

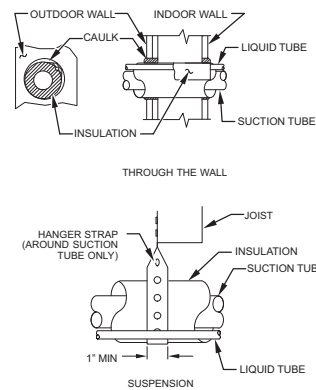

A07588

Fig. 1 – Connecting Tubing Installation

INSPECT NEW UNIT

File claim with shipping company prior to installation if shipment is damaged or incomplete. Locate unit rating plate on unit service panel. It contains information needed to properly install unit. Check rating plate to be sure unit matches job specifications.

LOCATION

Check local codes for regulations concerning zoning, noise, platforms, and other issues.

Locate unit away from fresh air intakes, vents, or bedroom windows. Noise may carry into the openings and disturb people inside.

Locate unit in a well drained area, or support unit high enough so that water runoff will not enter the unit.

Locate unit away from areas where heat, lint, or exhaust fumes will be discharged onto unit (as from dryer vents).

Locate unit away from recessed or confined areas where recirculation of discharge air may occur (refer to CLEARANCES section of this document).

Roof-top installation is acceptable providing the roof will support the unit and provisions are made for water drainage and noise/vibration dampening.

NOTE: Roof mounted units exposed to wind may require wind baffles. Consult the manufacturer for additional information.

INSTALL ON SOLID, LEVEL MOUNTING PAD

If conditions or local codes require the unit be attached to pad, tie-down bolts should be used and fastened through knockouts provided in unit base pan. Refer to unit mounting pattern in Fig. 2 to determine base pan size and knockout hole location.

Arrange supporting members to adequately support unit and minimize transmission of vibration to building. Consult local codes governing rooftop applications.

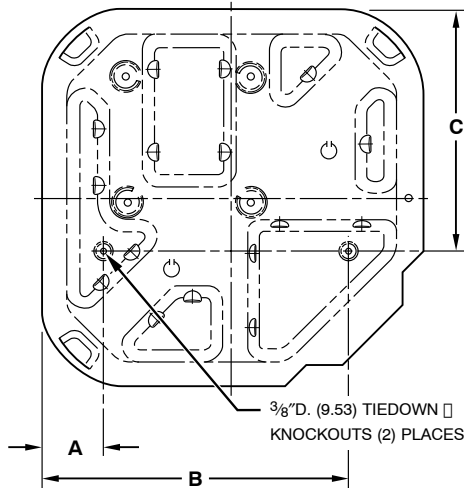

UNIT SIZE	MINIMUM MOUNTING PAD DIMENSIONS (cm)	TIEDOWN KNOCKOUT LOCATIONS (cm)		
		A	B	C
24	57 X 57	9.4	46	36.5
36-60	76 X 76	16.5	59.7	50.8

Fig. 2 – Tie Down Knockouts

CLEARANCES

When installing, allow sufficient space for airflow clearance, wiring, refrigerant piping, and service. Allow 76 cm clearance to service end of unit and 122 cm above unit. For proper airflow, a 15 cm clearance on 1 side of unit and 30.5 cm on all remaining sides must be maintained. Maintain a distance of 61cm between units. Position so water, snow, or ice from roof or eaves cannot fall directly on unit.

On rooftop applications, locate unit at least 15 cm above roof surface.

OPERATING AMBIENT

The minimum outdoor operating ambient in cooling mode without additional accessories is 13°C, and the maximum outdoor operating ambient in cooling mode is 52°C. The maximum outdoor operating ambient in heating mode is 19°C.

ELEVATE UNIT

Elevate unit per local climate and code requirements to provide clearance above estimated snowfall level and ensure adequate drainage of unit.

CAUTION

UNIT DAMAGE HAZARD

Failure to follow this caution may result in unit damage. Accumulation of water and ice in base pan may cause equipment damage.

REFRIGERATION SYSTEM

CHECK DEFROST THERMOSTAT

Check defrost thermostat to ensure it is properly located and securely attached. Find the liquid tube with a brass distributor and feeder tubes going into outdoor coil. At the end of one of the feeder tubes, there is a 9.5 mm OD stub tube approximately 7.6 cm long. (See Fig. 3.) The defrost thermostat should be located on stub tube. Note that there is only one stub tube used with feeder tube, and on most units it is the bottom circuit.

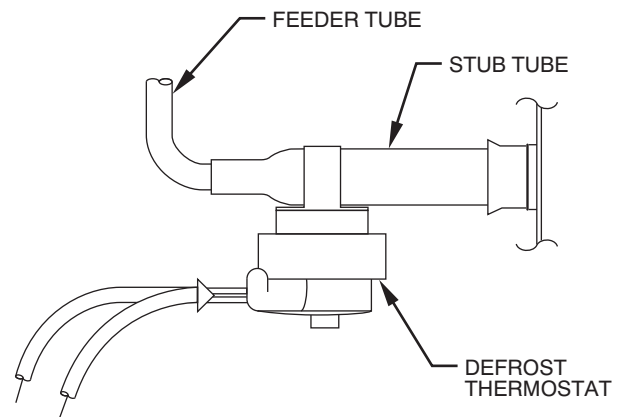

Fig. 3 – Defrost Thermostat Location

A97517

In Long-Line Applications, Install Liquid-Line Solenoid Valve (LSV)

For refrigerant piping arrangements with equivalent lengths greater than 15 m and/or when elevation difference between indoor and outdoor unit is greater than ±6 m, follow all requirements of the Long-Line Applications Guideline for R-410A Split Systems.

If required by Long Line Applications Guideline, install LSV kit part No. NASA001LS.

MAKING PIPING CONNECTIONS

⚠ WARNING

PERSONAL INJURY HAZARD
 Failure to relieve system pressure could result in personal injury and/or death.

Relieve pressure and recover all refrigerant before servicing existing equipment, and before final unit disposal. Use all service ports and open all flow-control devices, including solenoid valves.

Federal regulations require that you do not vent refrigerant to the atmosphere. Recover during system repair or final unit disposal.

⚠ CAUTION

UNIT OPERATION HAZARD
 Failure to follow this caution may result in improper product operation.

Do not leave system open to atmosphere any longer than absolutely required for installation. Internal system components – especially refrigerant oils – are extremely susceptible to moisture contamination. Keep ends of tubing sealed during installation until the last possible moment.

⚠ CAUTION

UNIT DAMAGE HAZARD
 Failure to follow this caution may result in unit damage.

If ANY refrigerant tubing is buried, provide a 15 cm vertical rise at service valve. Refrigerant tubing lengths up to 91 cm may be buried. Do NOT bury tubing lengths over 91 cm.

⚠ CAUTION

UNIT DAMAGE HAZARD
 Failure to follow this caution may result in unit component damage.
 Service valves must be wrapped while brazing in a heat sink material, such as a wet cloth.

Outdoor units may be connected to indoor section using accessory tubing package or field-supplied refrigerant grade tubing of correct size and condition. For tubing requirements beyond 15 m, substantial capacity and performance losses can occur. Follow the recommendations in the Long Line Applications Guideline. Refer to Table 1 for field tubing diameters. Refer to Table 2 for accessory requirements.

Refrigerant tubes and indoor coil must be evacuated to 500 microns to minimize contamination and moisture in the system.

Outdoor Unit Connected To Factory-Approved Indoor Unit

These outdoor units are carefully evaluated and listed with specific indoor coils for proper system performance.

IMPORTANT: Do not apply indoor coils which are not factory approved to these units.

INSTALL ADAPTER TUBE

1. Remove plastic retainer holding outdoor piston in liquid service valve.
2. Check outdoor piston size with matching number listed on unit rating plate.
3. Locate plastic bag taped to unit containing adapter tube.
4. Remove Teflon washer from bag and install on open end of liquid service valve. (See Fig. 4.)
5. Remove adapter tube from bag and connect threaded nut to liquid service valve. Tighten nut finger tight and then with wrench an additional 1/12 turn (15 ft-lb/20 n-m). DO NOT OVERTIGHTEN.

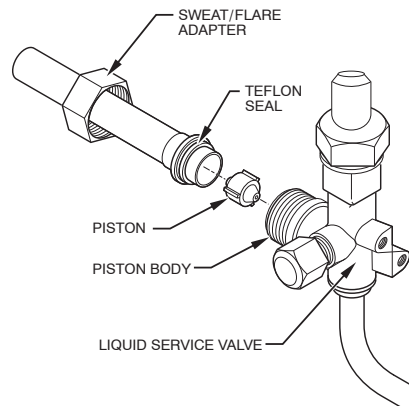

Fig. 4 – Liquid Service Valve with Sweat Adapter Tube

A01214

Table 1—Refrigerant Connections and Recommended Liquid Line and Vapor Tube Diameters – in. (mm)

UNIT SIZE	CONNECTION DIAMETER		TUBE DIAMETER		TUBE DIAMETER (ALTERNATE)
	Liquid	Rated Vapor*	Liquid	Rated Vapor*	Rated Vapor*
24	3/8 (9.5)	5/8 (15.9)	3/8 (9.5)	5/8 (15.9)	3/4 (19.1)
36	3/8 (9.5)	3/4 (19.1)	3/8 (9.5)	3/4 (19.1)	5/8, 7/8 (15.9, 22.2)
48	3/8 (9.5)	7/8 (22.2)	3/8 (9.5)	7/8 (22.2)	3/4 (19.1)
60	3/8 (9.5)	1-1/8 (28.6)	3/8 (9.5)	1-1/8 (28.6)	7/8 (22.2)

* Units are rated with 25 ft. (7.6 m) of lineset. See Product Data sheet for performance data when using different size and length linesets.

Notes:

1. Do not apply capillary tube indoor coils to these units.
2. For Tubing Set lengths between 80 and 200 ft. (24.38 and 60.96 m) horizontal or 20 ft. (6.1 m) vertical differential, refer to the Residential Longline Applications Guideline.

Table 2—Accessory Usage

ACCESSORY	REQUIRED FOR LOW-AMBIENT APPLICATIONS (BELOW 55°F/13°C)	REQUIRED FOR LONG-LINE APPLICATIONS* (OVER 50 FT/15 M)
Crankcase Heater	Yes	Yes
Evaporator Freeze Thermostat	Yes	No
Hard Start Kit—Capacitor and Relay	Yes	Yes
Low-Ambient Pressure Switch	Yes	No
Support Feet	Recommended	No
Liquid-Line Solenoid Valve for Heating	No	See Long-Line Applications Guideline

Refrigerant Piping and Filter Drier

⚠ CAUTION

UNIT DAMAGE HAZARD
 Failure to follow this caution may result in unit damage. Installation of filter drier in liquid line is required to avoid performance loss due to plugged circuits or plugged expansion devices, and to avoid compressor failure.

Connect vapor tubing to fittings on outdoor unit vapor service valves. Connect liquid tube to filter drier. (See Table 1 and Fig. 5.) Use refrigerant grade tubing. Connect other end of filter drier to adapter tube on liquid service valve.

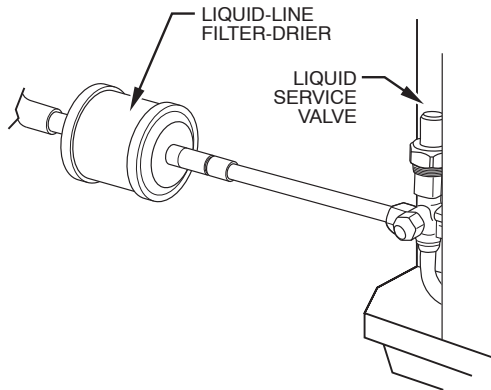

Fig. 5 – Filter Drier with Sweat Adapter Tube and Liquid Tube

A01215

Sweat Connection

⚠ CAUTION

UNIT DAMAGE HAZARD
 Failure to follow this caution may result in unit component damage. Service valves must be wrapped while brazing in a heat sink material, such as a wet cloth.

Wrap service valves and filter drier with a wet cloth or heatsinking material. Braze connections using either silver bearing or non-silver bearing brazing material. Do not use soft solder (materials which melt below 800°F/427°C.) Consult local code requirements.

Leak Checking

Leak test all joints in indoor, outdoor, and refrigerant tubing.

Evacuate Refrigerant Tubing And Indoor Coil

⚠ CAUTION

UNIT DAMAGE HAZARD
 Failure to follow this caution may result in unit component damage. To avoid compressor damage never use the system compressor as a vacuum pump.

Refrigerant tubes and indoor coil should be evacuated using the recommended deep vacuum method of 500 microns. The alternate triple evacuation method may be used if the procedure outlined below is followed.

IMPORTANT: Never open system under vacuum to atmosphere without first breaking it open with nitrogen.

Deep Vacuum Method

The deep vacuum method requires a vacuum pump capable of pulling a vacuum of 500 microns and a vacuum gage capable of accurately measuring this vacuum depth. The deep vacuum method is the most positive way of assuring a system is free of air and liquid water. (See Fig. 6.)

Triple Evacuation Method

The triple evacuation method should only be used when vacuum pump is only capable of pumping down to 28 in. (71 cm) of mercury vacuum and system does not contain any liquid water. Refer to Fig. 7 and proceed as follows:

1. Pump system down to 28 in. (71 cm) of mercury and allow pump to continue operating for an additional 15 minutes.
2. Close service valves and shut off vacuum pump.
3. Connect a nitrogen cylinder and regulator to system and open until system pressure is 2 psig (14 kPa).
4. Close service valve and allow system to stand for 1 hr. During this time, dry nitrogen will be able to diffuse throughout the system absorbing moisture.
5. Repeat this procedure as indicated in Fig.
6. System will then be free of any contaminants and water vapor.

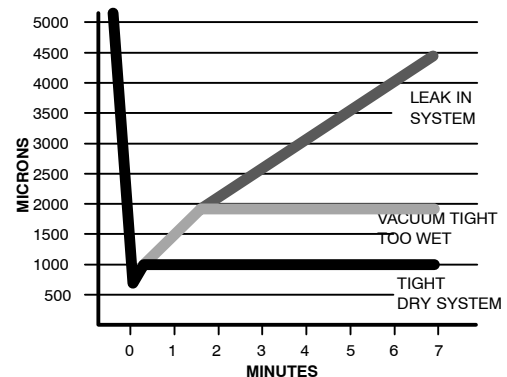

Fig. 6 – Deep Vacuum Graph

A95424

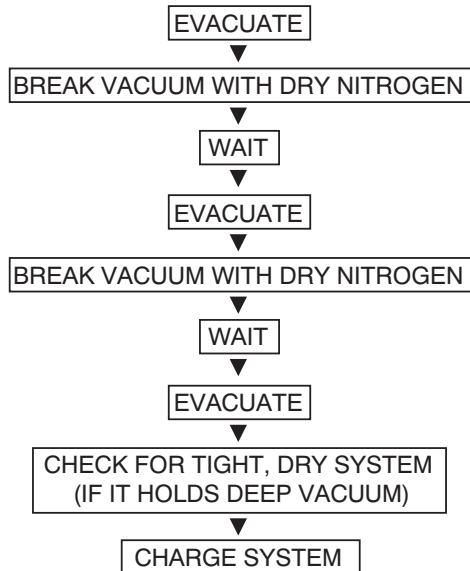

Fig. 7 – Triple Evacuation Method

A95425

Final Tubing Check

IMPORTANT: Check to be certain factory tubing on both indoor and outdoor unit has not shifted during shipment. Ensure tubes are not rubbing against each other or any sheet metal. Pay close attention to feeder tubes, making sure wire ties on feeder tubes are secure and tight.

ELECTRICAL CONNECTIONS

⚠ WARNING

ELECTRICAL SHOCK HAZARD
 Failure to follow this warning could result in personal injury or death.
 Do not supply power to unit with compressor terminal box cover removed.

Be sure field wiring complies with local and national fire, safety, and electrical codes, and voltage to system is within limits shown on unit rating plate. Contact local power company to correct improper voltage. See unit rating plate for recommended circuit protection device.

NOTE: Operation of unit on improper line voltage constitutes abuse and could affect unit reliability. See unit rating plate. Do not install unit in system where voltage or phase imbalance (3-phase) may fluctuate above or below permissible limits.

NOTE: Use copper wire only between disconnect switch and unit.

NOTE: Install branch circuit disconnect of adequate size per NEC to handle unit starting current. Locate disconnect within sight from and readily accessible from unit, per Section 440-14 of NEC or local code.

Route Ground and Power Wires

Remove access panel to gain access to unit wiring. Install conduit to knockout hole in bottom of control box. Extend power and ground leads into control box and connect to unit contactor and ground lug as shown on unit wiring diagram and Fig. 8. Consult IEC 60335-1, Part 25 for additional information.

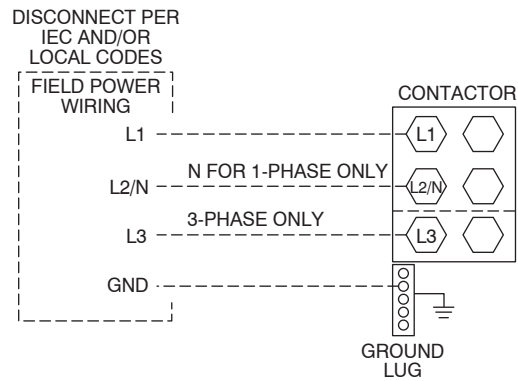

Fig. 8 – Line Power Connections

A03226

⚠ WARNING

ELECTRICAL SHOCK HAZARD
 Failure to follow this warning could result in personal injury or death.
 The unit cabinet must have an uninterrupted or unbroken ground. The ground may consist of electrical wire or metal conduit when installed in accordance with existing electrical codes.

Connect Control Wiring

Remove grommet from control wiring hole in control box. Install conduit to knockout hole in control box. Extend control wiring leads into control box and connect to terminal board as shown on unit wiring diagram and Fig. 9. Consult IEC 60335-1, Part 25 for additional information.

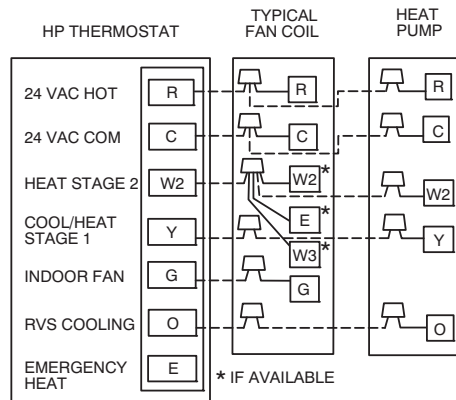

Fig. 9 – Generic Wiring Diagram

(See thermostat Installation Instructions for wiring specific unit combinations.)

A02325

Use No. 18 AWG color-coded, insulated (35°C minimum) wire. If thermostat is located more than 100 ft (30 m) from unit, as measured along the control voltage wires, use No. 16 AWG color-coded wire to avoid excessive voltage drop.

All wiring must be NEC Class 1 (US), or 245 IEC 57 and must be separated from incoming power leads. Wire insulation must conform to EN 60335-2-40.

Use fan coil transformer or accessory transformer for control power, 24v/40va minimum.

NOTE: Use of available 24v accessories may exceed the minimum 40va power requirement. Determine total

transformer loading and increase the transformer capacity or split the load with an accessory transformer as required.

Final Wiring Check

IMPORTANT: Check factory wiring and field wire connections to ensure terminations are secured properly. Check wire routing to ensure wires are not in contact with tubing, sheet metal, etc.

Compressor Crankcase Heater

When equipped with a crankcase heater, furnish power to heater a minimum of 24 hr before starting unit. To furnish power to heater only, set thermostat to OFF and close electrical disconnect to outdoor unit.

A For tubing sets lengths between 80 and 200 ft. (24 and 61 m) horizontal or 20 ft. (6 m) vertical differential, refer to the Residential Piping and Long Line Guideline.

Install Electrical Accessories

Refer to the individual instructions packaged with kits or accessories when installing.

START-UP

CAUTION

PERSONAL INJURY AND/OR EQUIPMENT DAMAGE HAZARD

Failure to follow this caution could result in personal and/or equipment damage.

- Do not overcharge system with refrigerant.
- Do not operate unit in a vacuum or at negative pressure.
- Do not disable low-pressure switch

In scroll compressor applications:

- Dome temperatures may be hot

CAUTION

PERSONAL INJURY HAZARD

Failure to follow this caution could result in personal injury.

Always wear safety glasses, protective clothing, and gloves when handling refrigerant.

WARNING

PERSONAL INJURY and ENVIRONMENTAL HAZARD

Failure to relieve system pressure could result in personal injury and/or death.

- Relieve pressure and recover all refrigerant before servicing existing equipment, and before final unit disposal. Use all service ports and open all flow-control devices, including solenoid valves.
- Federal regulations require that you do not vent refrigerant into the atmosphere. Recover during system repair or final unit disposal.

Follow these steps to properly start up the system:

- Fully back seat (open) liquid and vapor service valves.
- Unit is shipped with valve stem(s) front seated (closed) and caps installed. replace stem caps after system is opened to refrigerant flow (back seated). Replace caps finger-tight and tighten with wrench an additional 1/12

turn. Use a backup wrench on valve body flats to prevent distortion of sheet metal.

- Close electrical disconnects to energize system.
- Set room thermostat at desired temperature. Be sure set point is below indoor ambient temperature.
- Set room thermostat to HEAT or COOL and fan control to ON or AUTO mode, as desired. Operate unit for 15 minutes. Check system refrigerant charge.

CAUTION

UNIT DAMAGE HAZARD

Failure to follow this caution may result in unit damage.

- 3-phase scroll compressors are rotation sensitive.
- A flashing LED on phase monitor indicates reverse rotation. (See Fig. 10 and Table 3.)
- This will not allow contactor to be energized.
- Disconnect power to unit and interchange 2 field wiring leads on unit contactor.

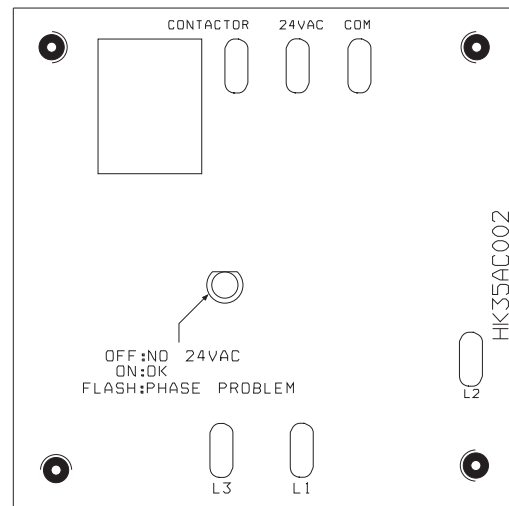

Fig. 10 – 3 Phase Monitor Control

A00010

Table 3—Phase-Monitor LED Indicators

LED	STATUS
OFF	No call for compressor operation
FLASHING	Reversed phase
ON	Normal

SEQUENCE OF OPERATION

NOTE: Defrost control board is equipped with 5 minute lockout timer that is initiated upon any interruption of power.

Turn on power to indoor and outdoor units. Transformer is energized.

Cooling

On a call for cooling, thermostat makes circuits R-O, R-Y, and R-G. Circuit R-O energizes reversing valve, switching it to cooling position. Circuit R-Y sends low voltage through the safeties and energizes the T1 terminal on the circuit board. If the compressor has been off for 5 minutes, or power has not been cycled for 5 minutes, the OF2 relay and T2 terminal will energize. This will close the contactor, and start the outdoor fan motor and compressor.

When the cycle is complete, R-Y is turned off, stopping the compressor and outdoor fan. The 5 minute time guard begins counting. Compressor will not come on again until this delay expires. In the event of a power interruption, the time guard will not allow another cycle for 5 minutes.

NOTE: If the indoor blower off delay is enabled, it will run up to an additional 90 seconds to increase system efficiency.

Heating

On a call for heating, thermostat makes circuits R-Y and R-G. Circuit R-Y sends low voltage through the safeties and energizes the T1 terminal on the circuit board. T1 energizes the defrost logic circuit. If the compressor has been off for 5 minutes, or power

has not been cycled for 5 minutes, the OF2 relay and T2 terminal will energize. This will close the contactor, start the outdoor fan motor and compressor.

When the cycle is complete, R-Y is turned off, stopping the compressor and outdoor fan. The 5 minute time guard begins counting. Compressor will not come on again until this time delay expires. In the event of a power interruption, the time guard will

not allow another cycle for 5 minutes.

Defrost:

The defrost control is a time/temperature control which includes a field-selectable (quick-connects located at board edge) time period between defrost cycles (30, 60, or 90 minutes), factory set at 60 minutes.

Defrost mode is identical to cooling mode except that outdoor fan motor stops and second-stage heat is turned on to continue warming conditioned space.

First the defrost cycle timer starts when the contactor is energized and a 24 volt signal is present on the T1 terminal. Then the defrost cycle begins when the cycle times out (30, 60, 90 min) and the defrost thermostat is closed.

To initiate defrost, the defrost thermostat must be closed. This can be accomplished as follows:

1. Turn off power to outdoor unit.
2. Disconnect outdoor fan motor lead from OF2 on control board. Tape lead to prevent grounding.
3. Restart unit in heating mode, allowing frost to accumulate on outdoor coil.
4. After a few minutes in heating mode, liquid line temperature should drop below closing point of defrost thermostat (approximately 30°F / -1.11°C).
5. Short between speed-up terminals with a flat-bladed screw-driver. (See Fig 11.) This reduces the timing sequence to 1/25th of original time. (See Table 4.)
6. When you hear reversing valve change position, remove screwdriver immediately; otherwise, control will terminate normal 10-minute defrost cycle in approximately 2 seconds

NOTE: Length of defrost cycle is dependent on the length of time it takes to remove screwdriver from test pins after reversing valve has shifted.

7. Unit will remain in defrost for remainder of defrost cycle time or until defrost thermostat reopens at approximately 80°F coil temperature of liquid line.
8. Turn off power to outdoor unit and reconnect fan motor lead to OF2 on control board.

Table 4—Defrost Control Speed-Up Timing Sequence

PARAMETER	MINIMUM (MINUTES)	MAXIMUM (MINUTES)	SPEED-UP (NOMINAL)
30-minute cycle	27	33	7 sec
60-minute cycle	56	66	14 sec
90-minute cycle	81	99	21 sec
10-minute cycle	9	11	2 sec

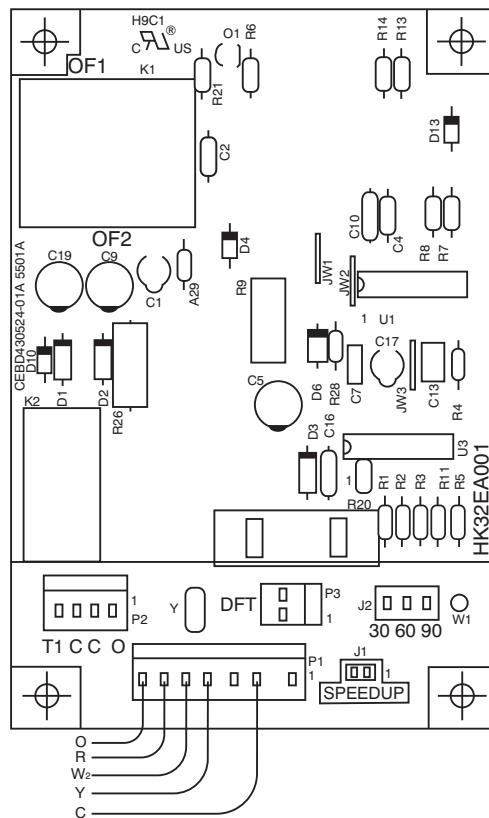

Fig. 11 – Defrost Control

A02001 Rev. B

REFRIGERANT CHARGE

Unit Charge

Factory charge is shown on unit rating plate. To check charge in cooling mode, refer to Cooling Only Procedure. To check charge in heating mode, refer to Heating Check Chart Procedure.

Cooling Only Procedure

NOTE: If superheat or subcooling charging conditions are not favorable, charge must be weighed in accordance with unit rating plate \pm 0.6 oz/ft of 3/8-in. (56g/m of 9.5 mm) liquid line above or below 15 ft (7.6 m) respectively.

EXAMPLE: To calculate additional charge required for a 10 m line set: 10 m - 7.6 m = 2.4 m X 56 g/m = 134.4 g of additional charge

The following procedure is valid when indoor airflow is within \pm 21 percent of its rated CFM.

1. Operate unit a minimum of 10 minutes before checking charge.
2. Measure suction pressure by attaching an accurate gage to suction valve service port.
3. Measure suction temperature by attaching an accurate thermistor type or electronic thermometer to suction line near service valve.
4. Measure outdoor air dry bulb temperature with thermometer.
5. Measure indoor air (entering indoor coil) wet bulb temperature with a sling psychrometer.
6. Refer to Table 5. Find outdoor temperature and evaporator entering air web bulb temperature. At this intersection, note superheat.

7. Refer to Table 6. Find superheat temperature located in item 6 and suction pressure. At this intersection, note suction line temperature.
8. If a unit has a higher suction line temperature than charted temperature, add refrigerant until charted temperature is reached.
9. If unit has a lower suction line temperature than charted temperature, reclaim refrigerant until charted temperature is reached.
10. When adding refrigerant, charge in liquid form into suction service port using a flow-restricting device.
11. If outdoor air temperature or pressure at suction valve changes, charge to new suction line temperature indicated on chart.

Table 5—Superheat Charging Table (SI)

OUTDOOR TEMP (°C)	EVAPORATOR ENTERING AIR TEMPERATURE (°C WB)														
	10	11	12	13	14	15	16	17	18	19	20	21	22	23	24
13	5.0	6.7	7.8	9.4	11.1	11.9	12.8	14.4	16.1	17.8	19.4	20.6	22.2	23.3	25.0
16	3.9	5.6	6.7	8.3	10.0	10.8	11.7	13.3	15.0	16.7	18.3	20.0	21.1	22.2	23.9
18	–	3.3	5.6	7.2	8.9	9.7	10.6	11.7	13.3	15.0	16.7	18.3	20.0	21.1	22.8
21	–	–	3.9	5.6	7.2	8.1	8.9	10.6	11.7	13.3	15.0	16.7	18.3	20.0	21.7
24	–	–	–	3.3	5.0	5.8	6.7	8.3	10.0	11.7	7.8	15.6	17.2	18.9	20.6
27	–	–	–	–	2.8	3.6	4.4	6.7	8.3	10.0	11.7	13.9	15.6	17.2	19.4
29	–	–	–	–	–	–	–	4.4	6.1	8.3	10.6	12.2	14.4	16.7	18.3
32	–	–	–	–	–	–	–	2.8	5.0	7.2	8.9	11.1	13.3	15.0	17.2
35	–	–	–	–	–	–	–	–	3.3	5.6	7.8	10.0	12.2	13.9	16.1
38	–	–	–	–	–	–	–	–	–	4.4	6.7	8.3	11.1	12.8	15.0
41	–	–	–	–	–	–	–	–	–	2.8	5.0	7.2	9.4	12.2	14.4
43	–	–	–	–	–	–	–	–	–	–	3.3	6.1	8.3	11.1	13.9
46	–	–	–	–	–	–	–	–	–	–	–	4.4	7.8	10.0	12.8

Where a dash (–) appears, do not attempt to charge system under these conditions, or refrigerant slugging may occur. Charge must be weighed in.

NOTE: Superheat °C is at low–side service port.

Table 6—Required Suction Line Temperature (°C)

SUPERHEAT TEMP (°C)	SUCTION PRESSURE AT SERVICE PORT (kPa)								
	743	774	805	836	869	902	957	971	1005
0	1.7	2.8	3.9	5.0	6.1	7.2	8.3	9.4	10.6
1	2.8	3.9	5.0	6.1	7.2	8.3	9.4	10.6	11.7
2	3.9	5.0	6.1	7.2	8.3	9.4	10.6	11.7	12.8
3	5.0	6.1	7.2	8.3	9.4	10.6	11.7	12.8	13.9
4	6.1	7.2	8.3	9.4	10.6	11.7	12.8	13.9	15.0
6	7.2	8.3	9.4	10.6	11.7	12.8	13.9	15.0	16.1
7	8.3	9.4	10.6	11.7	12.8	13.9	15.0	16.1	17.2
8	9.4	10.6	11.7	12.8	13.9	15.0	16.1	17.2	18.3
9	10.6	11.7	12.8	13.9	15.0	16.1	17.2	18.3	19.4
10	11.7	12.8	13.9	15.0	16.1	17.2	18.3	19.4	20.6
11	12.8	13.9	15.0	16.1	17.2	18.3	19.4	20.6	21.7
12	13.9	15.0	16.1	17.2	18.3	19.4	20.6	21.7	22.8
13	15.0	16.1	17.2	18.3	19.4	20.6	21.7	22.8	23.9
14	16.1	17.2	18.3	19.4	20.6	21.7	22.8	23.9	25.0
15	17.2	18.3	19.4	20.6	21.7	22.2	23.3	24.4	25.6
16	17.2	18.3	19.4	20.6	21.7	22.8	23.9	25.0	26.1
17	18.3	19.4	20.6	21.7	22.8	23.9	25.0	26.1	27.2
18	19.4	20.6	21.7	22.8	23.9	25.0	26.1	27.2	28.3
19	20.6	21.7	22.8	23.9	25.0	26.1	27.2	28.3	29.4
20	21.7	22.8	23.9	25.0	26.1	27.2	28.3	29.4	30.6
21	22.8	23.9	25.0	26.1	27.2	28.3	29.4	30.6	31.7
22	23.9	25.0	26.1	27.2	28.3	29.4	30.6	31.7	32.8

Heating Check Chart Procedure

To check system operation during heating cycle, refer to the Heat Pump Pressure chart label on outdoor unit. This chart indicates whether a correct relationship exists between system operating pressure and air temperature entering indoor and outdoor units. If pressure and temperature do not match on chart, system refrigerant charge may not be correct. Do not use chart to adjust refrigerant charge.

NOTE: In heating mode, check refrigerant charge only when pressures are stable. If in doubt, remove charge and weigh in correct refrigerant charge.

NOTE: When charging is necessary during heating season, charge must be weighed in accordance with unit rating plate and adjusted for interconnecting tubes greater than or less than 7.6 m.

Final Checks

IMPORTANT: Before leaving job, be sure to do the following:

1. Securely fasten all panels and covers.
2. Tighten service valve stem caps to 1/12–turn past finger tight.
3. Leave User’s Manual with owner. Explain system operation and periodic maintenance requirements outlined in manual. 4
4. Fill out Dealer Installation Checklist and place in customer file.

MAINTENANCE

For continuing high performance and to minimize possible equipment failure, periodic maintenance must be performed on this equipment.

Frequency of maintenance may vary depending upon geographic areas, such as coastal applications.

R-410A QUICK REFERENCE GUIDE

- R-410A refrigerant operates at 50–70 percent higher pressures than R-22. Be sure that servicing equipment and replacement components are designed to operate with R-410A refrigerant.
- R-410A refrigerant cylinders are rose colored.
- Recovery cylinder service pressure rating must be 400 psig, DOT 4BA400 or DOT BW400.
- R-410A refrigerant systems should be charged with liquid refrigerant. Use a commercial type metering device in the manifold hose when charging into suction line with compressor operating.
- Manifold sets should be 700 psig high side and 180 psig low side with 550 psig low-side retard.
- Use hoses with 700 psig service pressure rating.
- Leak detectors should be designed to detect HFC refrigerant.
- R-410A refrigerant, as with other HFCs, is only compatible with POE oils.
- Vacuum pumps will not remove moisture from oil.
- Do not use liquid-line filter driers with rated working pressures less than 600 psig.
- Do not leave R-410A refrigerant suction line filter driers in line longer than 72 hours.
- Do not install a suction-line filter drier in liquid-line.
- POE oils absorb moisture rapidly. Do not expose oil to atmosphere.
- POE oils may cause damage to certain plastics and roofing materials.
- Wrap all filter driers and service valves with wet cloth when brazing.
- A factory-approved liquid-line filter drier is required on every unit.
- Do NOT use an R-22 TXV.
- If indoor unit is equipped with an R-22 TXV, it must be changed to a hard-shutoff R-410A refrigerant TXV.
- Never open system to atmosphere while it is under a vacuum.
- When system must be opened for service, recover refrigerant, evacuate then break vacuum with dry nitrogen and replace filter driers. Evacuate to 500 microns prior to recharging.
- Do not vent R-410A refrigerant into the atmosphere.
- Do not use capillary tube coils.
- Observe all **warnings**, **cautions**, and **bold** text.
- All indoor coils must be installed with a hard-shutoff R-410A refrigerant TXV metering device.