

Installation Instructions

DNECOMZR024A02, DNECOMZR025A02

Horizontal Economizer Accessory For Rooftop Units 3 to 12 ½ Tons

Read these instructions completely before attempting to install the accessory Economizer.

Field-installed CO2 sensors are available.

CONTENTS

	Page
SAFETY CONSIDERATIONS	1
GENERAL	1
ACCESSORIES LIST	2
INSTALLATION	2-4
Economizer.....	2
CONFIGURATION	4-9
Economizer Standard Sensors	4
Economizer Control Modes.....	5
OPERATION	9
Sequence of Operation.....	9
Performance Data.....	9
TROUBLESHOOTING	10,11

Standard barometric relief dampers provide natural building pressurization control. An optional power exhaust system is available for applications requiring even greater exhaust capabilities. The power exhaust set point is adjustable at the Economizer controller.

See Table 1 for package usage. See Table 2 for package contents. See Table 3 for sensor usage.

Table 1 – Package Usage

UNIT SIZE	PART NUMBER
STANDARD EFFICIENCY Small Cabinet 3 to 6 Ton HIGH EFFICIENCY 3 – 5 Ton	DNECOMZR024A02
STANDARD EFFICIENCY Large Cabinet 7 ½ to 12 ½ Ton HIGH EFFICIENCY 6 – 8 ½ Ton	DNECOMZR025A02

SAFETY CONSIDERATIONS

Installation and servicing of air-conditioning equipment can be hazardous due to system pressure and electrical components. Only trained and qualified service personnel should install, repair, or service air-conditioning equipment.

Untrained personnel can perform the basic maintenance functions of replacing filters. All other operations should be performed by trained service personnel. When working on air-conditioning equipment, observe precautions in the literature, tags and labels attached to the unit, and other safety precautions that may apply.

WARNING

TURN OFF UNIT POWER and lock out. Electrical shock, personal injury, OR DEATH could result.

GENERAL

The Economizer system utilizes the latest technology available for integrating the use of free cooling with mechanical cooling for packaged rooftop units. The solid-state control system optimizes energy consumption, zone comfort, and equipment cycling by operating the compressors when the outdoor-air temperature is too warm, integrating the compressor with outdoor air when free cooling is available, and locking out the compressor when outdoor-air temperature is too cold. Demand ventilation is supported.

The Economizer system utilizes gear-drive technology with a direct-mount spring return actuator that will close upon loss of power. The Economizer system comes standard with an outdoor air temperature sensor, supply air temperature sensor, and low temperature compressor lockout switch. Indoor enthalpy and outdoor enthalpy sensors are available for field Installation.

Table 2 – Package Contents

ACCESSORY	QTY	CONTENTS
DNECOMZR024A02	1	Hood Assembly
	1	Filter Access Door
	1	Aluminum Filter
	18	Screws
	1	Economizer Assembly
DNECOMZR025A02	1	Supply Air Temperature Sensor
	1	Hood Assembly
	1	Filter Access Door
	1	Aluminum Filter
	18	Screws
	1	Economizer Assembly
1	Supply Air Temperature Sensor	
1	Front Blank Off Panel	
1	Horizontal Blank Off Panel	

Table 3 – Economizer Sensor Usage

APPLICATION	ECONOMIZER WITH OUTDOOR AIR DRY BULB
	Accessories Required
Outdoor Air Dry Bulb	None. The outdoor air dry bulb sensor is factory installed
Single Enthalpy	AXB078ENT
Differential Enthalpy	AXB078ENT and DNENTDIF004A00*
CO2 for DCV Control using a Wall-Mounted CO2 Sensor	DNCBDIOX005A00**

*DNENTDIF004A00 accessories are used on many different base units. As such, these Kits may contain parts that will not be needed for installation. Required for duct-mounted applications.
 **DNCBDIOX005A00 is an accessory that contains both 33ZSENCO2 – CO2SENSOR
 And 33ZCASPCO2 – Aspirator box accessories.

ACCESSORIES LIST

The Economizer has several field-installed accessories available to optimize performance. Refer to Table 4 for authorized parts.

Table 4 — Economizer Field-Installed Accessories

DESCRIPTION	PART NUMBER
3-6 Ton Power Exhaust 208V-230V 1Ph	DNPWREXH030A01
3-6 Ton Power Exhaust 460V 3Ph	DNPWREXH021A01
7 1/2-12 1/2 Ton Power Exhaust 208-230V 1Ph	DNPWREXH022A01
7 1/2-12 1/2 Ton Power Exhaust 460V 3Ph	DNPWREXH023A01
Outdoor Air Enthalpy Sensor	AXB078ENT
Indoor Air Enthalpy Sensor	DNENTDIF004A00
CO2 Room Sensor and Aspirator Box	DNCBDIOX005A00
Return Air CO2 Sensor (4 to 20 mA)	DNCBDIOX002A00

INSTALLATION

Economizer - See Fig. 1 for Economizer component locations. To install the horizontal Economizer, perform the following procedure:

1. Turn off unit power supply and install lockout tag.

⚠ WARNING

TURN OFF UNIT POWER and install lock out tag before attempting to install accessory. Electrical shock, personal injury, OR DEATH could result.

2. Remove the existing unit filter access panel. Raise the panel and swing the bottom outward. The panel is now disengaged from the track and can be removed and discarded. See Fig. 2.
3. Remove the indoor coil access panel and discard. See Fig. 2.
4. The Economizer hood assembly is shipped assembled. Aluminum filter must be installed on some models.
5. To install the filter, open the filter clips which are located underneath the hood top. Insert the aluminum filter into the bottom filter rack (hood divider). Push the filter into position past the open filter clips. Close the filter clips to lock the filter into place. See Fig. 3.
6. Set the Economizer upright as shown in Fig. 4.
7. Insert the Economizer assembly into the rooftop unit, positioning the Economizer to the far left side of the opening. See Fig. 5.
8. Slide the Economizer all the way back into the unit until it locks into the horizontal opening of the HVAC (heating, ventilation and air conditioning) unit.

9. Secure the Economizer mounting flanges to the HVAC unit with the screws provided. See Fig. 6.
10. Install a screw through the pre-punched hole in the Economizer into the flange on the horizontal duct opening. See Fig. 7.

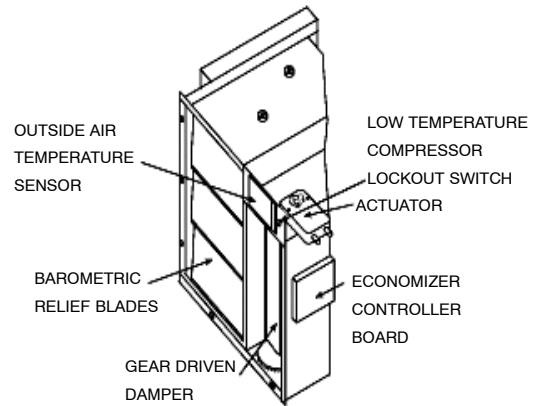

Fig. 1- Economizer Component Locations

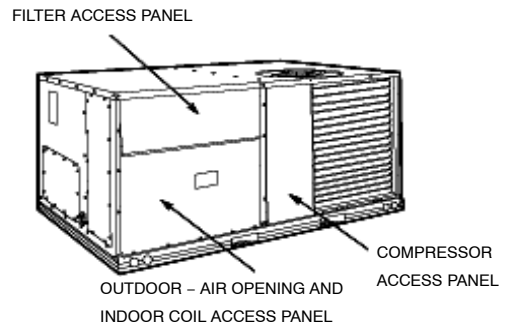

Fig. 2- Typical Outdoor Air Section Access Panel Locations

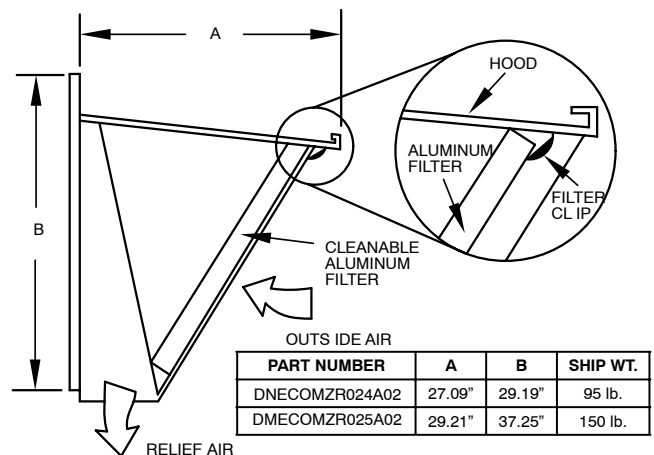

Fig. 3- Economizer Hood Detail

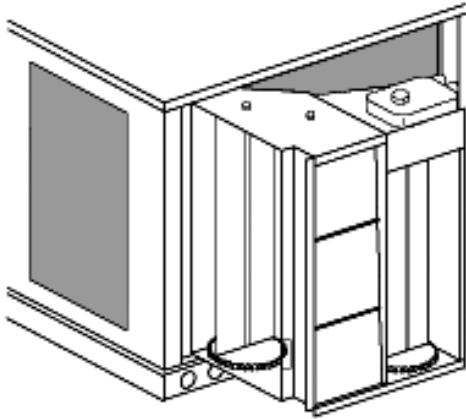

Fig. 4- Economizer Positioned for Installation in Unit

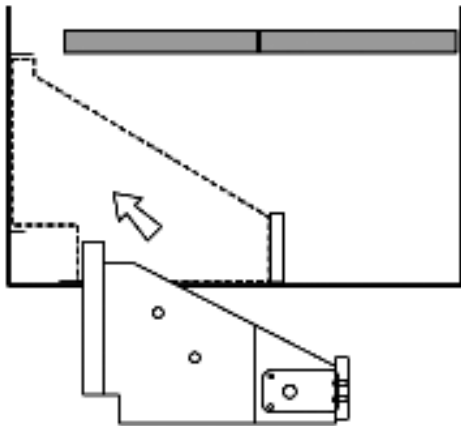

Fig. 5- Top View of Economizer Installation

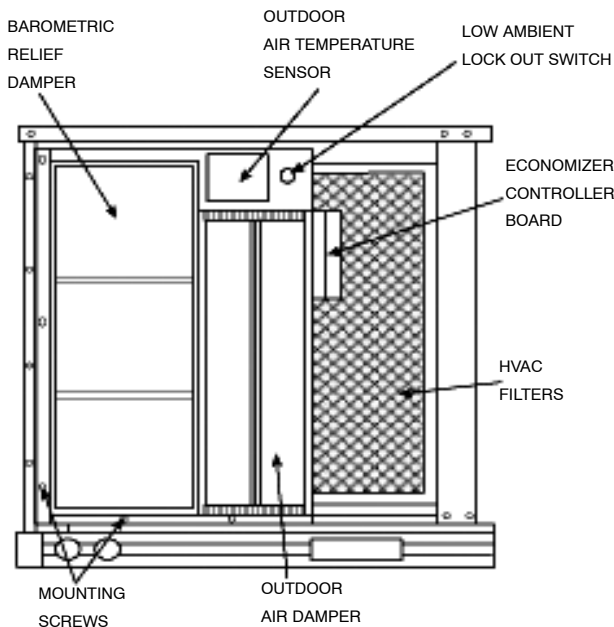

Fig. 6- Economizer installed in unit

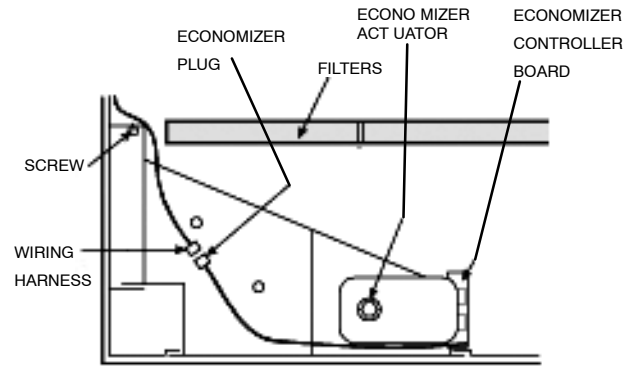

Fig. 7- Top View of Economizer

11. Remove and save the 12-pin jumper plug from the unit wiring harness (located in the upper left corner of the unit). Insert the Economizer plug into the unit wiring harness. See Fig. 7. Refer to Fig. 8 for wiring diagram. NOTE: The 12-pin jumper plug should be saved for future use, in the event that the Economizer is removed from the unit. The jumper plug is not needed as long as the Economizer is installed.
12. Remove the indoor fan motor access panel. See Fig. 9
13. The supply air temperature sensor looks like an eyelet terminal with wires running to it. The sensor is located on the "crimp end" and is sealed from moisture. Mount the supply air temperature sensor (provided) to the lower left section of the indoor fan blower housing. See Fig. 10 Use the screw provided and use existing hole. Connect the violet and pink wires to the corresponding connections on the supply air temperature sensor. See Fig 8
NOTE: Be sure that the arrow on the actuator motor is pointing to "Run" and not to "Test." If the arrow is at "Test," the Economizer damper will drive open.
14. Review the controller setting options in the Operation section.
 - a. The standard Economizer controller has a factory setting of 63 F for the outdoor air temperature changeover and 55 F for the supply air temperature sensor. The outdoor air temperature setting can be adjusted on the sensor by setting the dip switches on the sensor. See Fig. 15. The ABCD potentiometer on the economizer Controller should be set to the "D" position.
 - b. The low temperature compressor lockout switch setting is fixed at 42 F.
 - c. The minimum position for the outdoor damper can be configured at the controller. When not using a CO2 sensor, the DCV Max potentiometer must be completely closed (CCW) for Minimum Position potentiometer to function correctly.
15. Replace the indoor fan motor access panel.
16. Remove the tape securing the relief dampers in place.
17. Install the Economizer hood over the Economizer. Use screws provided. See Fig. 11 and 12. Insert screw through right side flange of hood into Economizer flange.
18. Install access door next to hood. Screw bottom of door to HVAC unit. See Fig. 11 and 12.
19. Panels for tall units. On 6, 10, 12 ½ Ton units, install front blank off above hood. Screw in place. See Fig. 12. On 12 ½ Ton units, install the horizontal blank-off at the Top of the return air opening. See Fig. 13. Screw in Place through pre-punched holes.
20. Install all Economizer accessories

Fig. 8

Economizer Wiring

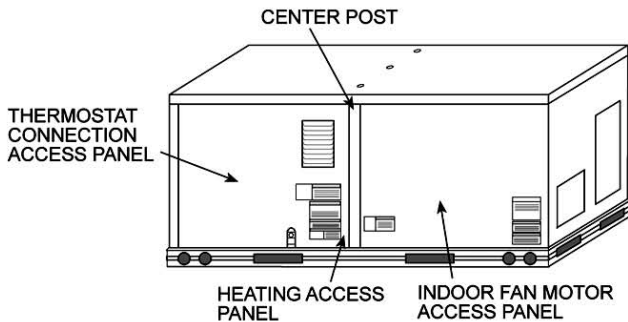
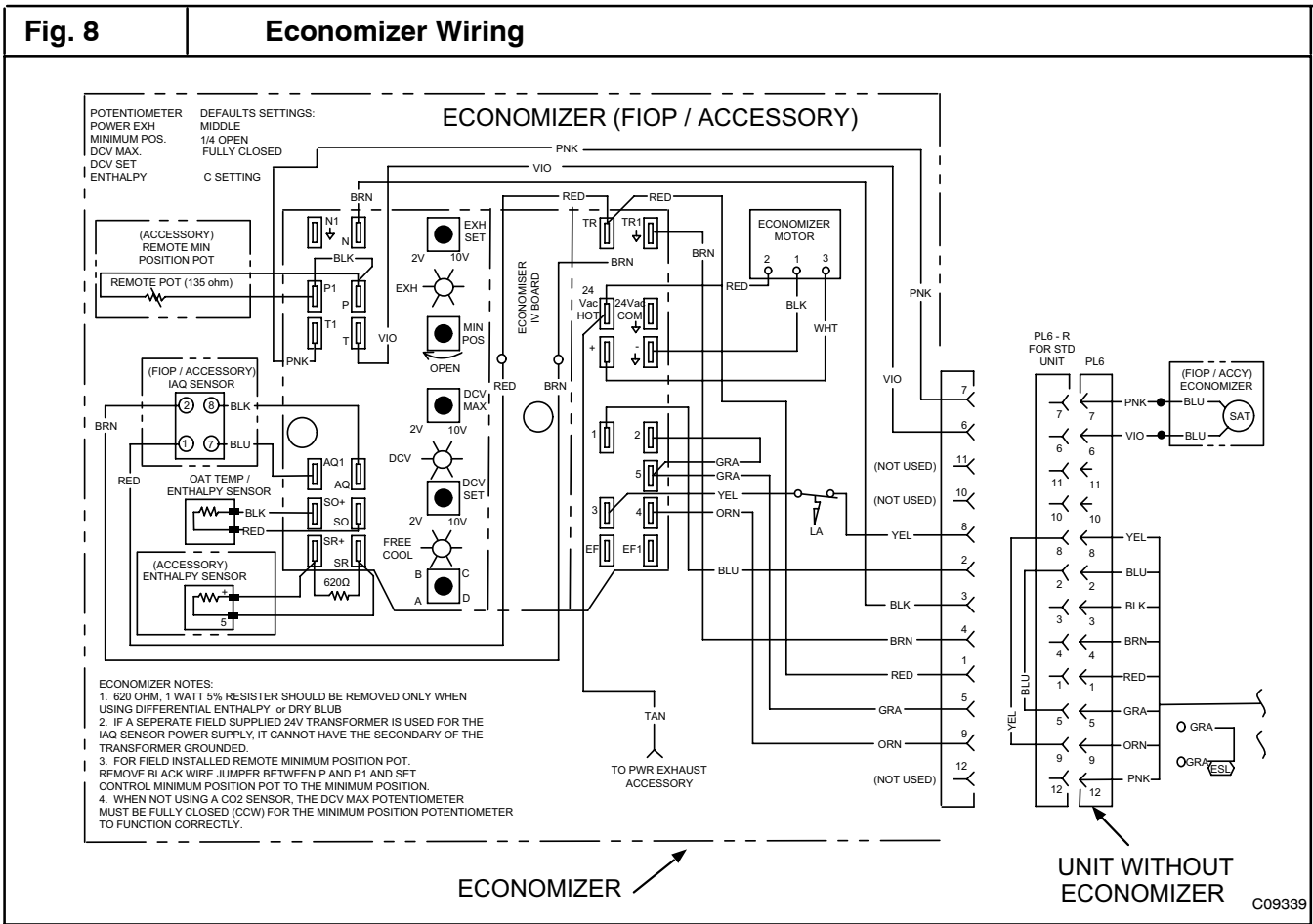

Fig. 9- Typical Indoor Fan Motor Access Panel Locations

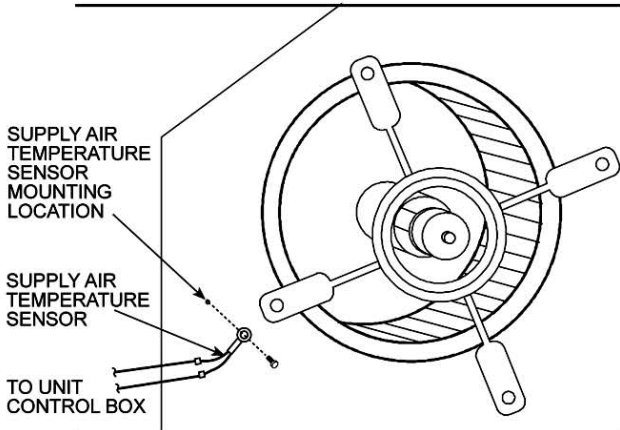

Fig. 10- Supply Air Sensor Installation Location

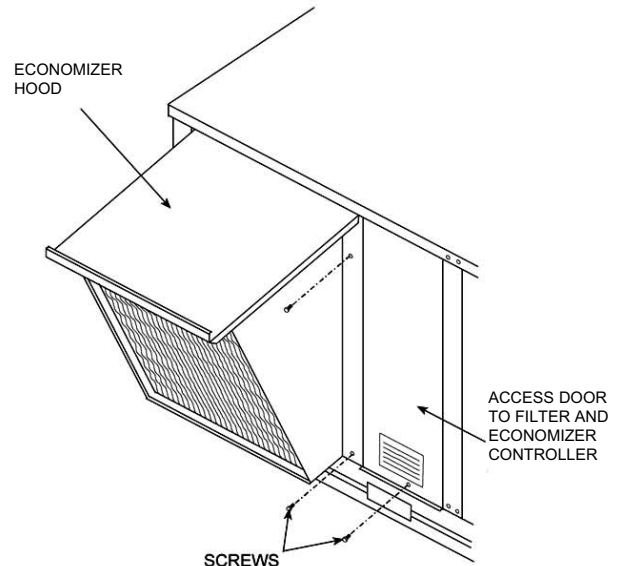

Fig. 11- Economizer Hood Installation (5 Ton Unit Shown)

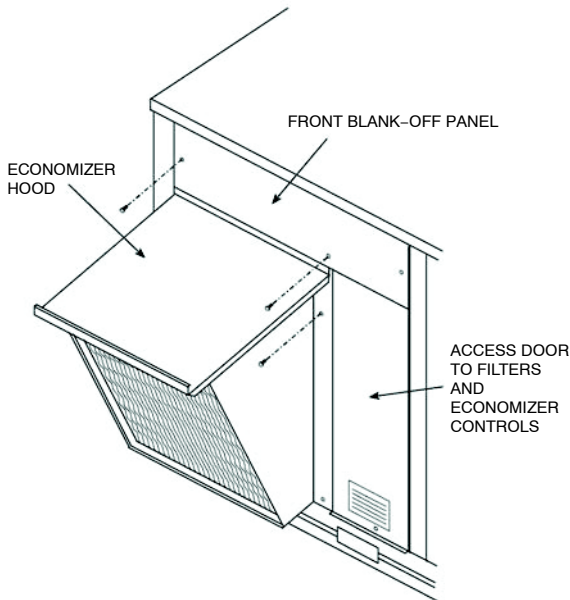

Fig. 12- Front Blank-Off Panel Installation Panel (6,10 & 12-1/2 Ton Units)

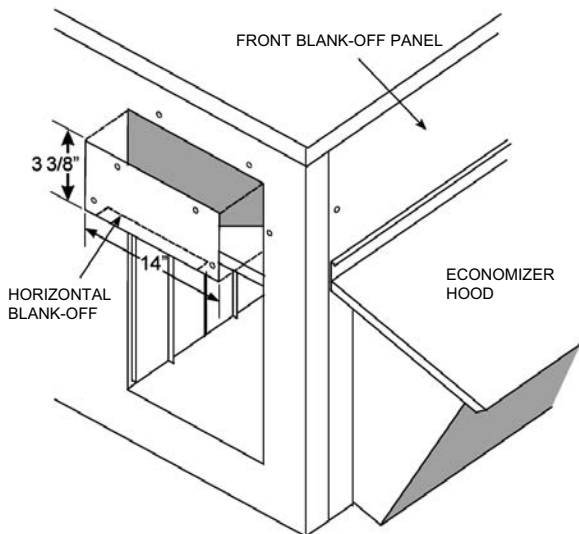

Fig. 13- Horizontal Return Opening Blank-Off Panel (10 and 12-1/2 Ton Units)

CONFIGURATION

Economizer Standard Sensors

OUTDOOR AIR TEMPERATURE (OAT) SENSOR - The outdoor air temperature sensor (HH57AC080) is a 10 to 20mA device used to measure the outdoor-air temperature. The outdoor-air temperature is used to determine when the Economizer can be used for free cooling. The sensor is factory-installed on the Economizer in the outdoor airstream. See Fig. 1. The sensor has 8 selectable temperature changeover set points, ranging from 48 F to 78 F. The temperature changeover is set using the 3 dip switches on the sensor. See Fig 15. The ABCD potentiometer should be set to the "D" position.

SUPPLY AIR TEMPERATURE (SAT) SENSOR - The supply air temperature sensor is a 3 K thermistor located at the inlet of the indoor fan. See Fig. 10. This sensor is field installed. The operating range of temperature measurement is 0° to 158°F. See Table 5 for sensor temperature/resistance values.

The temperature sensor looks like an eyelet terminal with wires running to it. The sensor is located in the "crimp end" and is sealed from moisture.

Table 5- Supply Air Sensor Temperature/Resistance Values

TEMPERATURE (F)	RESISTANCE (ohms)
-58	200.250
-40	100.680
-22	53.010
-4	29.091
14	16.590
32	9.795
50	5.970
68	3.747
77	3.000
86	2.416
104	1.597
122	1.080
140	746
158	525
176	376
185	321
194	274
212	203
230	153
248	116
257	102
266	89
284	70
302	55

LOW TEMPERATURE COMPRESSOR LOCKOUT SWITCH — The Economizer is equipped with a low ambient temperature lockout switch located in the outdoor airstream which is used to lock out the compressors below a 42 F ambient temperature. See Fig. 1.

Economizer Control Modes - Determine the Economizer control mode before set up of the control. Some modes of operation may require different sensors. Refer to Table 3. The Economizer is supplied from the factory with a supply air temperature sensor, a low ambient lockout sensor, and an outdoor air temperature sensor. This allows for operation of the Economizer with outdoor air dry bulb changeover control. Additional accessories can be added to allow for different types of changeover control and operation of the Economizer and unit.

OUTDOOR DRY BULB CHANGEOVER – The standard controller is shipped from the factory configured for outdoor dry bulb changeover control. The outdoor air and supply air temperature sensors are included as standard. For this control mode, the outdoor temperature is compared to an adjustable set point selected on the sensor. If the outdoor-air temperature is above the set point, the Economizer will adjust the outdoor air dampers to minimum position. If the outdoor-air temperature is below the set point, the position of the outdoor-air dampers will be controlled to provide free cooling using outdoor air. When in this mode, the LED next to the A, B, C, D potentiometer will be on. The changeover temperature set point is controlled by the switches on the sensor. See Fig. 15 for the corresponding temperature changeover values.

OUTDOOR ENTHALPY CHANGEOVER - For enthalpy control, accessory enthalpy sensor is required. Replace the standard outdoor dry bulb temperature sensor with the accessory enthalpy sensor in the same

mounting location. See Fig. 1. When the outdoor air enthalpy rises above the outdoor enthalpy changeover set point, the outdoor-air damper moves to its minimum position. The outdoor enthalpy changeover set point is set with the outdoor enthalpy set point potentiometer on the Economizer controller. The set points are A, B, C, and D. See Fig. 17. The factory-installed 620-ohm jumper must be in place across terminals SR and SR+ on the Economizer controller. See Fig. 18

DIFFERENTIAL ENTHALPY CONTROL - For differential enthalpy control, the Economizer controller uses two enthalpy sensors (AXBO78ENT and DNENTDIF004A00), one in the outside air and one in the return airstream. The Economizer controller compares the outdoor air enthalpy to the return air enthalpy to determine Economizer use. The controller selects the lower enthalpy air (return or outdoor) for cooling. For example, when the outdoor air has a lower enthalpy than the return air and is below the set point, the opens to bring in outdoor air for free cooling.

Replace the standard outside air dry bulb temperature sensor with the accessory enthalpy sensor in the same mounting location. See Fig. 1. Mount the return air enthalpy sensor in the return air duct. See Fig. 16. See Fig. 8. When using this mode of changeover control, turn the enthalpy set point potentiometer fully clockwise to the D setting.

INDOOR AIR QUALITY (IAQ) SENSOR INPUT - The IAQ input can be used for demand control ventilation control based on the level of CO2 measured in the space or return air duct. Mount the accessory IAQ sensor according to manufacturer specifications. The IAQ sensor should be wired to the AQ and AQ1 terminals of the controller. Adjust the DCV potentiometers to correspond to the DCV voltage output of the indoor air quality sensor at the user-determined set point. See Fig. 19. If a separate field-supplied transformer is used to power the IAQ sensor, the sensor must not be grounded or the Economizer control board will be damaged.

EXHAUST SET POINT ADJUSTMENT - The exhaust set point will determine when the exhaust fan runs based on damper position (if accessory power exhaust is installed). The set point is modified with the Exhaust Fan Set Point (EXH SET) potentiometer. See Fig. 14. The set point represents the damper position above which the exhaust fans will be turned on. When there is a call for exhaust, the Economizer controller provides a 45 ± 15 second delay before exhaust fan activation to allow the dampers to open. This delay allows the damper to reach the appropriate position to avoid unnecessary fan overload.

MINIMUM POSITION CONTROL - There is a minimum damper position potentiometer on the Economizer controller. See Fig. 14. The minimum damper position maintains the minimum airflow into the building during the occupied period.

When using demand ventilation, the minimum damper position represents the minimum ventilation position for VOC (volatile organic compound) ventilation requirements. The maximum demand ventilation position is used for fully occupied ventilation.

When demand ventilation control is not being used, the minimum position potentiometer should be used to set the occupied ventilation position. The DCV Max potentiometer must be fully closed (CCW) to allow Minimum Position potentiometer to function correctly.

Adjust the minimum position potentiometer to allow the minimum amount of outdoor air, as required by local codes, to

enter the building. Make minimum position adjustments with at least 10 F temperature difference between the outdoor and return-air temperatures.

To determine the minimum position setting, perform the following procedure:

1. Calculate the appropriate mixed air temperature using the following formula:

$$(T_o \times OA/100) + (T_R \times RA/100) = T_M$$

T_o = Outdoor-Air Temperature

OA = Percent of Outdoor Air

T_R = Return-Air Temperature

RA = Percent of Return Air

T_M = Mixed-Air Temperature

As an example, if local codes require 10% outdoor air during occupied conditions, outdoor-air temperature is 60 F, and return-air temperature is 75 F.

$$(60 \times .10) + (75 \times .90) = 73.5 \text{ F}$$

2. Disconnect the supply air sensor from terminals T and T1.

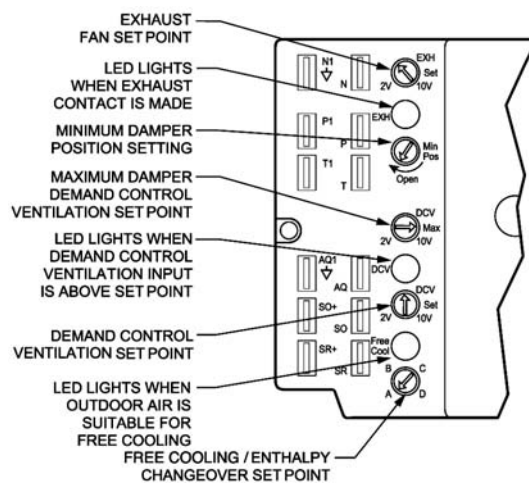

Fig. 14– Economizer Controller Potentiometer and LED Locations

DIP SWITCH POSITION	CHANGEOVER TEMPERATURE
ON OFF 1 2 3	48°F
ON OFF 1 2 3	53°F
ON OFF 1 2 3	55°F
ON OFF 1 2 3	58°F
ON OFF 1 2 3	63°F
ON OFF 1 2 3	68°F
ON OFF 1 2 3	73°F
ON OFF 1 2 3	78°F

M27636
Selectable Temperature Options

Fig. 15– Outdoor Air Temperature Changeover Set Points

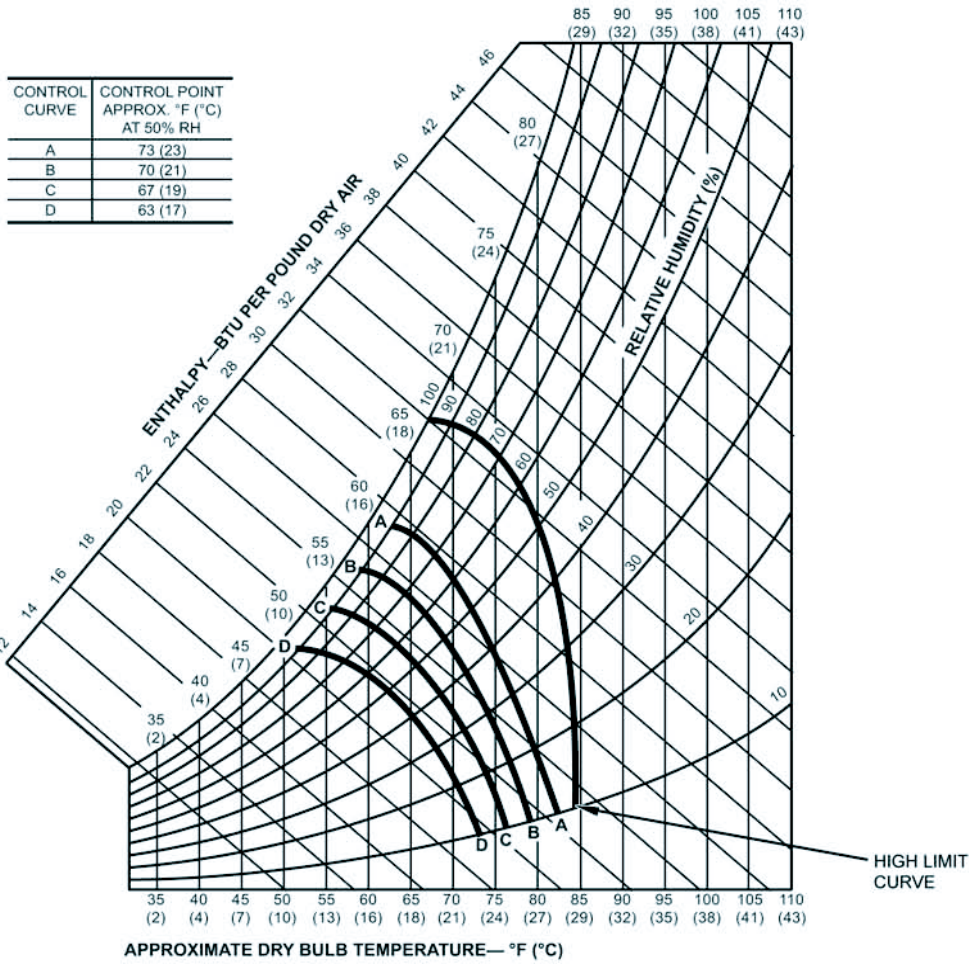

Fig. 17 - Enthalpy Changeover Set Point

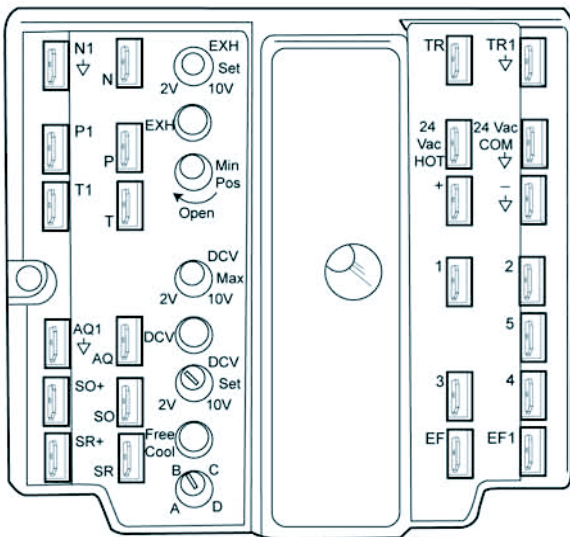

Fig. 18 - Economizer Controller

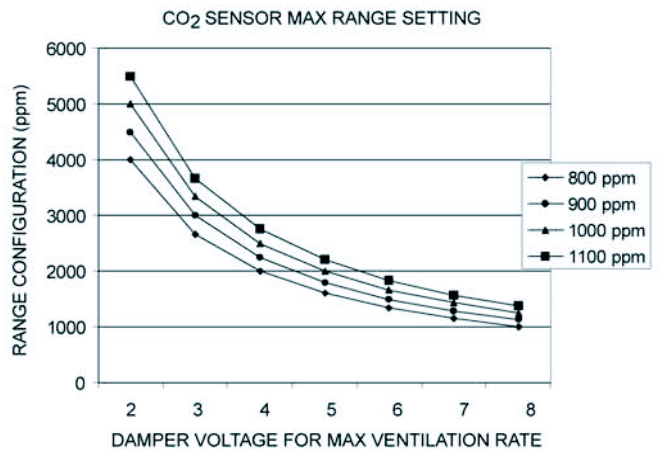

Fig. 19 - CO₂ Sensor Maximum Range Setting

3. Ensure that the factory-installed jumper is in place across terminals P and P1. If remote damper positioning is being used, make sure that the terminals are wired according to Fig. 8 and that the minimum position potentiometer is turned fully clockwise.
4. Connect 24 vac across terminals TR and TR1
5. Carefully adjust the minimum position potentiometer until the measured mixed-air temperature matches the calculated value.
6. Reconnect the supply air sensor to terminals T and T1.

Remote control of the Economizer damper is desirable when requiring additional temporary ventilation. If a field-supplied remote potentiometer (Honeywell part number S963B1128) is wired to the Economizer controller, the minimum position of the damper can be controlled from a remote location.

To control the minimum damper position remotely, remove the factory-installed jumper on the P and P1 terminals on the Economizer controller. Wire the field-supplied potentiometer to the P and P1 terminals on the Economizer controller. See Fig. 18.

DAMPER MOVEMENT - Damper movement from full open to full closed (or vice versa) takes 2 1/2 minutes.

THERMOSTATS— The Economizer control works with conventional thermostats that have a Y1 (cool stage 1), Y2 (cool stage 2), w1 (heat stage 1), W2 (heat stage 2), and G (fan). The Economizer control does not support space temperature sensors. Connections are made at the thermostat terminal connection board located in the main control box.

OCCUPANCY CONTROL - The factory default configuration for the Economizer control is occupied mode. Occupied status is provided by the black wire from pin #3 when unoccupied mode is desired. Install a field supplied timeclock function in place of the jumper between TR and N. See Fig. 8. When the timeclock contacts are closed, the Economizer control will be in occupied mode. When the timeclock contacts are open (removing the 24-v signal from terminal N), the Economizer will be in unoccupied mode.

DEMAND CONTROLLED VENTILATION (DCV)-When using the Economizer for demand controlled ventilation, there are some equipment selection criteria which should be considered. When selecting the heat capacity and cool capacity of the equipment, the maximum ventilation rate must be evaluated for design conditions. The maximum damper position must be calculated to provide the desired fresh air.

Typically the maximum ventilation rate will be about 5 to 10% more than the typical cfm required per person, using normal outside air design criteria.

An exponential anticipatory strategy should be taken with the following conditions: a zone with a large area, varied occupancy, and equipment that cannot exceed the required ventilation rate at design conditions. Exceeding the required ventilation rate means the equipment can condition air at a maximum ventilation rate that is greater than the required ventilation rate for maximum occupancy. An exponential-anticipatory strategy will cause the fresh air supplied to increase as the room CO2 level increase even though the CO2 set point has not been reached. By the time the CO2 level reaches the set point, the damper will be at maximum ventilation and should maintain the set point.

In order to have the CO2 sensor control the economizer damper in this manner, first determine the damper voltage output for minimum or base ventilation. Base ventilation is the ventilation required to remove contaminants during unoccupied periods. The following equation may be used to determine the percent of outside-air entering the building for a given damper position. For best results there should be at least a 10 degree difference in outside and return-air temperatures.

$$(TO \times OA/100) + (TR \times RA/100) = TM$$

TO = Outdoor-Air Temperature
 OA = Percent of Outdoor Air
 TR = Return-Air Temperature
 RA = Percent of Return Air
 TM = Mixed-Air Temperature

Once base ventilation has been determined, set the minimum damper position potentiometer to the correct position.

The same equation can be used to determine the occupied or maximum ventilation rate to the building. For example, an output of 3.6 volts to the actuator provides a base ventilation rate of 5% and an output of 6.7 volts provides the maximum ventilation rate of 20% (or base plus 15 cfm per person). Use Fig. 19 to determine the maximum setting of the CO2 sensor. For example, a 1100 ppm set point relates to a 15 cfm per person design. Use the 1100 ppm curve on Fig. 19 to find the point when the CO2 sensor output will be 6.7 volts. Line up the point on the graph with the left side of the chart to determine that the range configuration for the CO2 sensor should be 1800 ppm. The Economizer controller will output the 6.7 volts from the CO2 sensor to the actuator when the CO2 concentration in the space is 1100 ppm. The DCV set point may be left at 2 volts since the CO2 sensor voltage will be ignored by the Economizer controller until it rises above the 3.6 volt setting of the minimum position potentiometer.

Once the fully occupied damper position has been determined, set the maximum damper demand control ventilation potentiometer to this position. Do not set to the maximum position as this can result in over-ventilation to the space and potential high-humidity levels.

CO2 SENSOR CONFIGURATION- The CO2 sensor has preset standard voltage settings that can be selected anytime after the sensor is powered up. See Table 6.

Use setting 1 or 2 for Carrier equipment. See Table 6.

1. Press Clear and Mode Buttons. Hold at least 5 seconds until the sensor enters the Edit mode.
2. Press Mode twice. The STD SET Menu will appear.
3. Use the Up/Down button to select the preset number. See Table 6.
4. Press Enter to lock in the selection.
5. Press Mode to exit and resume normal operations.

The custom settings of the CO2 sensor can be changed anytime after the sensor is energized. Follow the steps below to change the non-standard settings:

1. Press Clear and Mode buttons. Hold at least 5 seconds until the sensor enters the Edit mode.
2. Press Mode twice. The STD SET Menu will appear.
3. Use the Up/Down button to toggle to the NON STD menu and press Enter.
4. Use the Up/Down button to toggle through each of the nine variables, starting with Altitude, until the desired setting is reached.
5. Press Mode to move through the variables.
6. Press Enter to lock in the selection, then press Mode to continue to the next variable.

DEHUMIDIFICATION OF FRESH AIR WITH DCV CONTROL- Information from ASHRAE indicates that the largest humidity load on any zone is the fresh air introduced. For some applications, an energy recovery unit can be added to reduce the moisture content of the fresh air being brought into the building when the enthalpy is high. In most cases, the normal heating and cooling processes are more than adequate to remove the humidity loads for most commercial applications.

If normal rooftop heating and cooling operation is not adequate for the outdoor humidity level, an energy recovery unit and/or a dehumidification option should be considered.

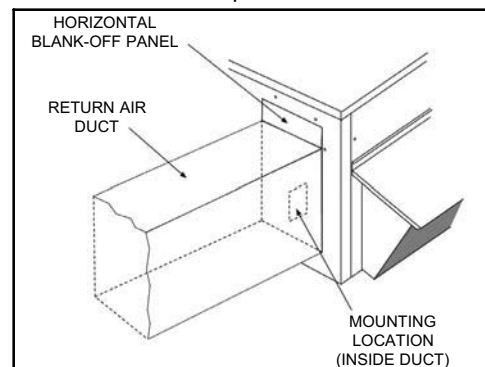

Fig. 16- Outdoor Air Enthalpy sensor Mounting Location (10 to 12-1/2 Ton Units)

Table 6– CO2 Sensor Standard Settings

SETTING	EQUIPMENT	OUTPUT	VENTILATION RATE (cfm/Person)	ANALOG OUTPUT	CO ₂ CONTROL RANGE (ppm)	OPTIONAL RELAY SETPOINT (ppm)	RELAY HYSTERESIS (ppm)
1	Interface w/Standard Building Control System	Proportional	Any	0-10V 4-20 mA	0-2000	1000	50
2		Proportional	Any	2-10V 7-20 mA	0-2000	1000	50
3		Exponential	Any	0-10V 4-20 mA	0-2000	1100	50
4	Economizer	Proportional	15	0-10V 4-20 mA	0-1100	1100	50
5		Proportional	20	0-10V 4-20 mA	0- 900	900	50
6		Exponential	15	0-10V 4-20 mA	0-1100	1100	50
7		Exponential	20	0-10V 4-20 mA	0- 900	900	50
8	Health & Safety	Proportional	—	0-10V 4-20 mA	0-9999	5000	500
9	Parking/Air Intakes/ Loading Docks	Proportional	—	0-10V 4-20 mA	0-2000	700	50

LEGEND

ppm — Parts Per Million

OPERATION

Sequence of Operation -When free cooling is not available, the compressors will be controlled by the zone thermostat. When free cooling is available, the outdoor-air damper is modulated by the Economizer control to provide a 50 to 55 F supply-air temperature into the zone. As the supply-air temperature fluctuates above 55 or below 50 F, the dampers will be modulated (open or close) to bring the supply-air temperature back within the set points limits.

For Economizer operation, there must be a thermostat call for the fan (G). This will move the damper to its minimum position during the occupied mode.

Above 50 F supply-air temperature, the dampers will modulate from 100% open to the minimum open position. From 50 F to 45 F supply-air temperature, the dampers will maintain at the minimum open position. below 45 F the dampers will be completely shut. As the supply-air temperature rises, the dampers will come back open to the minimum open position once the supply air temperature rises to 48 F.

If optional power exhaust is installed, as the outdoor-air damper opens and closes, the power exhaust fans will be energized and deenergized.

If field-installed accessory CO2 sensors are connected to the Economizer control, a demand controlled ventilation strategy will begin to operate. As the CO2 level in the zone increases above the CO2 set point, the minimum position of the damper will be increased proportionally. As the CO2 level decreases because of the increase in fresh air, the outdoor-air damper will be proportionally closed. Damper position will follow the higher demand condition from DCV mode or free cooling mode.

Damper movement from full closed to full open (or vice versa) will take between 1 -1/2 and 2 -1/2 minutes. If free cooling can be used as determined from the appropriate changeover command (dry bulb, enthalpy curve, or differential enthalpy) a call for cooling (Y1 closes at the thermostat) will cause the control to modulate the dampers open to maintain the supply air temperature set point at 50 to 55 F.

As the supply air temperature drops below the set point range of 50 to 55 F, the control will modulate the outdoor-air dampers closed to maintain the proper supply-air temperature.

Performance Data -Refer to Fig. 20 for barometric relief capacity. Refer to Fig. 21 for outdoor air leakage. Refer to Fig. 22 for return air pressure drop.

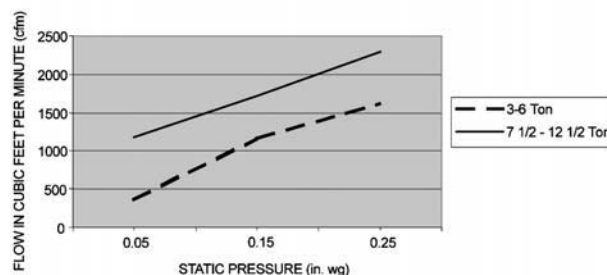

Fig. 20 — Barometric Flow Capacity

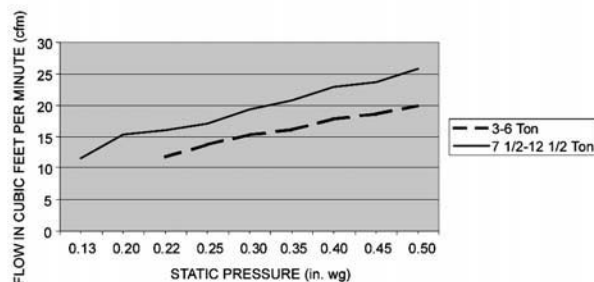

Fig. 21 — Outdoor-Air Damper Leakage

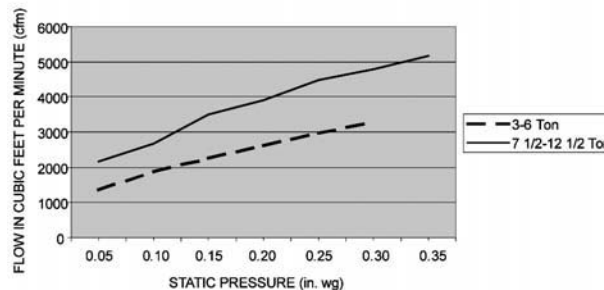

Fig. 22 — Return-Air Pressure Drop

TROUBLESHOOTING

See Table 7 for Economizer logic.

A functional view of the EconoMizer is shown in Fig. 23. Typical settings, sensor ranges, and jumper positions are also shown. An Economizer simulator program is available to help with Economizer training and troubleshooting.

Economizer Preparation -This procedure is used to prepare the Economizer for troubleshooting. No troubleshooting or testing is done by performing the following procedure. NOTE: This procedure requires a 9-v battery, 1.2 kilo-ohm resistor, and a 5.6 kilo-ohm resistor which are not supplied with the Economizer.

IMPORTANT: Be sure to record the positions of all potentiometers before starting troubleshooting.

1. Disconnect power at TR and T R1. All LEDs should be off. Exhaust fan contacts should be open.
2. Disconnect device at P and P1.
3. Jumper P to P1.
4. Disconnect wires at T and T1. Place 5.6 kilo-ohm resistor across T and T1.
5. Jumper TR to 1.
6. Jumper TR to N.
7. If connected, remove sensor from terminals SO and +. Connect 1.2 kilo-ohm 4074 EJM checkout resistor across terminals SO and +.
8. Put 620-ohm resistor across terminals SR and +.
9. Set minimum position, DCV set point, and exhaust potentiometers fully CCW (counterclockwise).
10. Set DCV maximum position potentiometer fully CW (clockwise).
11. Set enthalpy potentiometer to D.
12. Apply power (24 vac) to terminals TR and TR1.

Differential Enthalpy -To check differential enthalpy:

1. Make sure Economizer preparation procedure has been performed.
2. Place 620-ohm resistor across SO and +.
3. Place 1.2 kilo-ohm resistor across SR and +. The Free Cool LED should be lit.
4. Remove 620-ohm resistor across SO and +. The Free Cool LED should turn off.
5. Return Economizer settings and wiring to normal after completing troubleshooting.

Single Enthalpy -To check single enthalpy:

1. Make sure Economizer preparation procedure has been performed.
2. Set the enthalpy potentiometer to A (fully CCW). The Free Cool LED should be lit.
3. Set the enthalpy potentiometer to D (fully CW). The Free Cool LED should turn off.
4. Return Economizer settings and wiring to normal after completing troubleshooting.

DCV (Demand Controlled Ventilation) and

Power Exhaust -To check DCV and Power Exhaust:

1. Make sure Economizer preparation procedure has been performed.

Note: DCV Max potentiometer must be fully closed (CCW) when CO2 sensor is not used.

2. Ensure terminals AQ and AQ1 are open. The LED for both DCV and Exhaust should be off. The actuator should be fully closed.
3. Connect a 9-v battery to AQ (positive node) and AQ1 (negative node). The LED for both DCV and Exhaust should turn on. The actuator should drive to between 90 and 95% open.
4. Turn the Exhaust potentiometer CW until the Exhaust LED turns off. The LED should turn off when the potentiometer is approximately 90%. The actuator should remain in position.
5. Turn the DCV set point potentiometer CW until the DCV LED turns off. The DCV LED should turn off when the potentiometer is approximately 9-v. The actuator should drive fully closed.
6. Turn the DCV and Exhaust potentiometers CCW until the Exhaust LED turns on. The exhaust contacts will close 30 to 120 seconds after the Exhaust LED turns on.
7. Return Economizer settings and wiring to normal after completing troubleshooting.

DCV Minimum and Maximum Position - To check the DCV minimum and maximum position:

1. Make sure Economizer preparation procedure has been performed.
2. Connect a 9-v battery to AQ (positive node) and AQ1 (negative node). The DCV LED should turn on. The actuator should drive to between 90 and 95% open.
3. Turn the DCV Maximum Position potentiometer to mid point. The actuator should drive to between 20 and 80% open.
4. Turn the DCV Maximum Position potentiometer to fully CCW. The actuator should drive fully closed.
5. Turn the Minimum Position potentiometer to midpoint. The actuator should drive to between 20 and 80% open.
6. Turn the Minimum Position Potentiometer fully CW. The actuator should drive fully open.
7. Remove the jumper from TR and N. The actuator should drive fully closed.
8. Return Economizer settings and wiring to normal after completing troubleshooting.

Supply-Air Input - To check supply-air input:

1. Make sure Economizer preparation procedure has been performed.
2. Set the Enthalpy potentiometer to A. The Free Cool LED turns on. The actuator should drive to between 20 and 80% open.
3. Remove the 5.6 kilo-ohm resistor and jumper T to T1. The actuator should drive fully open.
4. Remove the jumper across T and T1. The actuator should drive fully closed.
5. Return Economizer settings and wiring to normal after completing troubleshooting.

Economizer Troubleshooting Completion -

This procedure is used to return the Economizer to operation. No troubleshooting or testing is done by performing the following procedure.

1. Disconnect power at TR and T R1.
2. Set enthalpy potentiometer to previous setting.
3. Set DCV maximum position potentiometer to previous setting.
4. Set minimum position, DCV set point, and exhaust potentiometers to previous settings.

5. Remove 620-ohm resistor from terminals SR and +.
6. Remove 1.2 kilo-ohm checkout resistor from terminals SO and +. If used, reconnect sensor from terminals SO and +.
7. Remove jumper from TR to N.
8. Remove jumper from TR to 1.
9. Remove 5.6 kilo-ohm resistor from T and T1. Reconnect wires at T and T1.
10. Remove jumper from P to P1. Reconnect device at P and P1.
11. Apply power (24 vac) to terminals TR and TR1.

Table 7– Economizer Input/Output Logic

Demand Control Ventilation (DCV)	INPUTS				OUTPUTS			
	Enthalpy*		Y1	Y2	Compressor		N Terminal†	
	Outdoor	Return			Stage 1	Stage 2	Occupied	Unoccupied
Below set (DCV LED Off)	High (Free Cooling LED Off)	Low	On	On	On	On	Minimum position	Closed
			On	Off	On	Off		
			Off	Off	Off	Off		
	Low (Free Cooling LED On)	High	On	On	On	Off	Modulating** (between min. position and full-open)	Modulating** (between closed and full-open)
			On	Off	Off	Off		
			Off	Off	Off	Off		
Above set (DCV LED On)	High (Free Cooling LED Off)	Low	On	On	On	On	Modulating†† (between min. position and DCV maximum)	Modulating†† (between closed and DCV maximum)
			On	Off	On	Off		
			Off	Off	Off	Off		
	Low (Free Cooling LED On)	High	On	On	On	Off	Modulating***	Modulating†††
			On	Off	Off	Off		
			Off	Off	Off	Off		

*For single enthalpy control, the module compares outdoor enthalpy to the ABCD set point.

†Power at N terminal determines Occupied/Unoccupied setting: 24 vac (Occupied), no power (Unoccupied).

**Modulation is based on the supply-air sensor signal.

††Modulation is based on the DCV signal.

***Modulation is based on the greater of DCV and supply-air sensor signals, between minimum position and either maximum position (DCV) or fully open (supply-air signal).

†††Modulation is based on the greater of DCV and supply-air sensor signals, between closed and either maximum position (DCV) or fully open (supply-air signal).

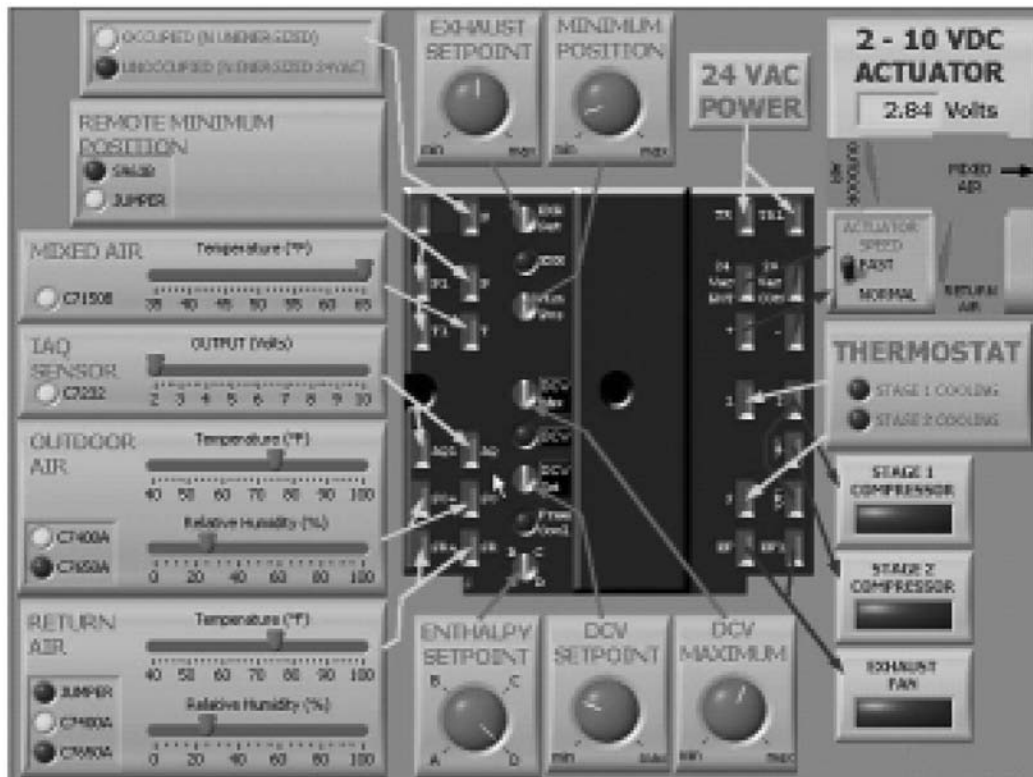

Fig. 23– Economizer Functional View