



EFFICIENT 13 SEER 3-PHASE AIR CONDITIONER ENVIRONMENTALLY SOUND R-410A REFRIGERANT

3 THRU 5 TONS SPLIT SYSTEM

208 / 230 Volt, 3-phase, 60 Hz

460 Volt, 3-phase, 60 Hz

REFRIGERATION CIRCUIT

- Copeland Scroll™ compressors on all models
- Crankcase Heaters factory installed on all models
- Filter-Drier supplied with every unit for field installation
- High and Low pressure switches
- Low ambient feature allows safe operation down to 20° F outdoor temperature*
- Copper tube / aluminum fin coil

PERFORMANCE

- 2-speed Fan Motors factory wired on all models
- Compressor Sound Jacket standard

EASY TO INSTALL AND SERVICE

- Comfort Alert™ Diagnostics device on all models*
- Easy Access service valves on all models
- Compressor access panel
- New, innovative control box design
- External high and low refrigerant service ports
- Fan motor in-line disconnect plug
- Only two screws to access control panel
- Factory charged with R-410A refrigerant

BUILT TO LAST

- High gloss, baked-on powder coat finish over galvanized steel
- Post-painted (black) coil fins
- Coated, weather-resistant cabinet screws
- Coated inlet grille with 3/8" spacing for extra protection
- Corner Posts for extra strength and style
- 5 year compressor, 1 year coil and parts limited warranties



Rated in accordance with ARI Standard 210. Certification applies only when used with proper components as listed with ARI.



Model Number	Voltage	Size (tons)	Nominal Btu/hr	Min. Circuit Ampacity	Max. Fuse or Breaker	Operating Dim's h x w x d (in)	Ship / Operating Weight (lbs)
H4A336GHB	208/230	3	36,000	15.2	20	39 ³ / ₈ × 31 ¹ / ₁₆ × 32 ⁵ / ₁₆	215 / 187
H4A336GLB	460			7.8	15		
H4A342GHB	208/230	3½	42,000	17.9	25	43½ × 35 × 36 ⁹ / ₁₆	282 / 248
H4A342GLB	460			8.2	15		
H4A348GHB	208/230	4	48,000	18.7	30	43½ × 35 × 36 ⁹ / ₁₆	285 / 251
H4A348GLB	460			8.4	15		
H4A360GHB	208/230	5	60,000	22.7	35	36 ³ / ₄ × 35 × 36 ⁹ / ₁₆	299 / 265
H4A360GLB	460			10.3	15		

*NOTE: Previous GHA/GLA models do not feature the Comfort Alert™ Diagnostics device or low ambient control.

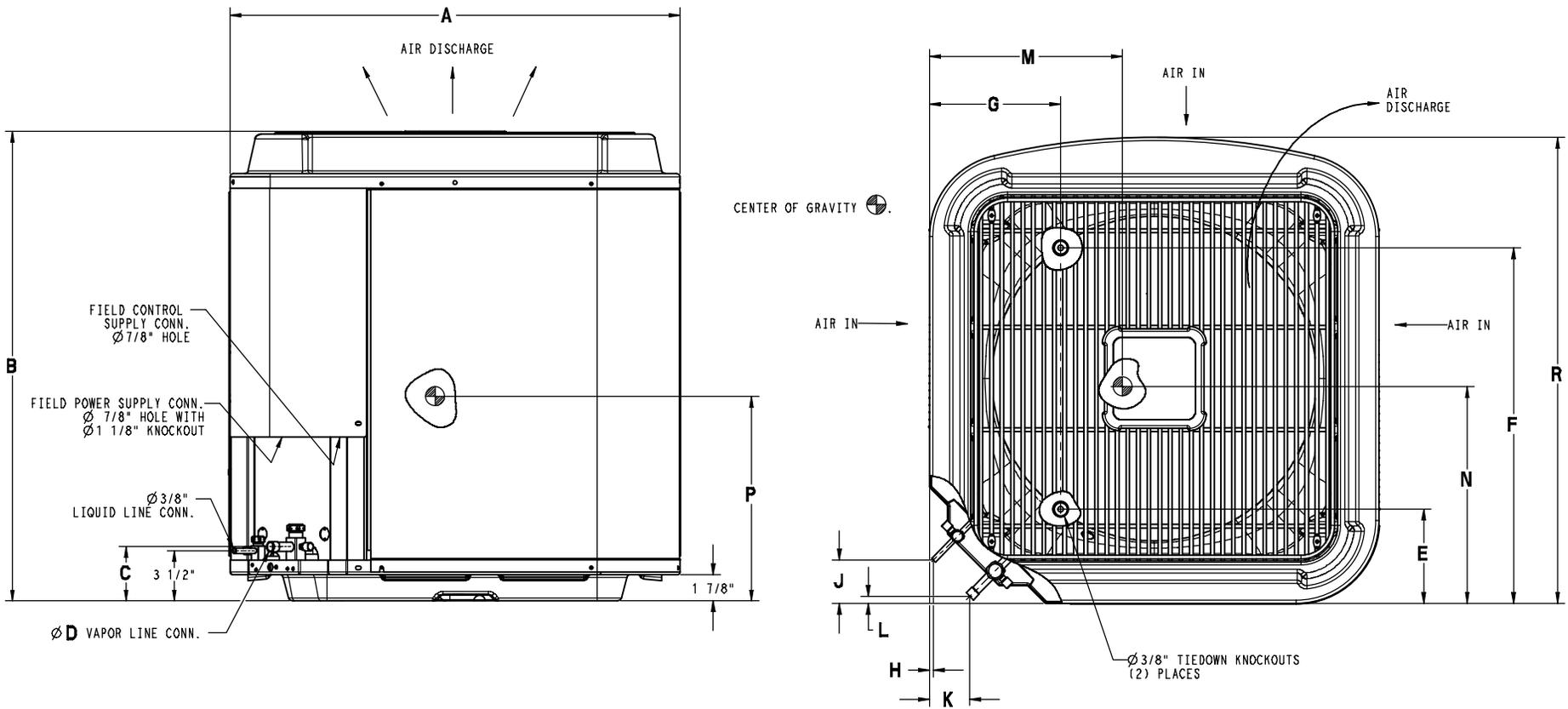

Model * = H or L	All Dimensions Inches															Minimum Mounting Pad Size	Crated Dimensions B(h) x A(w) x R(d)
	A	B	C	D	E	F	G	H	J	K	L	M	N	P	R		
H4A336G*B	31 ³ / ₁₆	39 ³ / ₈	3 ³ / ₄	3 ¹ / ₄	6 ⁹ / ₁₆	24 ¹¹ / ₁₆	9 ¹ / ₈	5 ¹ / ₁₆	3	2 ¹³ / ₁₆	1 ¹ / ₂	19 ³ / ₄	18	20 ¹ / ₄	32 ⁵ / ₁₆	31 ¹ / ₂ x 32 ¹ / ₂	46 ³ / ₁₆ x 35 ¹ / ₂ x 32 ³ / ₈
H4A342G*B	35	43 ¹ / ₂	3 ⁷ / ₈	7 ¹ / ₈	6 ⁹ / ₁₆	24 ¹¹ / ₁₆	9 ¹ / ₈	5 ¹ / ₁₆	3	2 ¹⁵ / ₁₆	5 ¹ / ₈	19 ³ / ₄	18	20 ¹ / ₄	36 ⁹ / ₁₆	35 x 36 ¹ / ₂	49 ⁹ / ₁₆ x 39 ⁵ / ₁₆ x 36 ¹ / ₈
H4A348G*B	35	43 ¹ / ₂	3 ⁷ / ₈	7 ¹ / ₈	6 ⁹ / ₁₆	24 ¹¹ / ₁₆	9 ¹ / ₈	5 ¹ / ₁₆	3	2 ¹⁵ / ₁₆	5 ¹ / ₈	19 ³ / ₄	18	20 ¹ / ₄	36 ⁹ / ₁₆	35 x 36 ¹ / ₂	49 ⁹ / ₁₆ x 39 ⁵ / ₁₆ x 36 ¹ / ₈
H4A360G*B	35	36 ³ / ₄	3 ⁷ / ₈	7 ¹ / ₈	6 ⁹ / ₁₆	24 ¹¹ / ₁₆	9 ¹ / ₈	5 ¹ / ₁₆	3	2 ¹⁵ / ₁₆	5 ¹ / ₈	19	18	15 ¹ / ₄	36 ⁹ / ₁₆	35 x 36 ¹ / ₂	42 ³ / ₄ x 39 ⁵ / ₁₆ x 36 ¹ / ₈

PHYSICAL DATA								
Model Size	36GH	36GL	42GH	42GL	48GH	48GL	60GH	60GL
Nominal Cooling Capacity (BTU/hr)	36,000		42,000		48,000		60,000	
Nominal SEER	13.0		13.0		13.0		13.0	
Sound Rating, High Spd Fan (dBA)	75		76		76		76	
Low Spd Fan (dBA)	72		74		74		75	
PSC Fan Motor HP	1/5		1/5		1/4		1/4	
Fan RPM High	825		825		825		825	
Fan RPM Low	750		750		750		750	
Fan CFM (High)	2800		3270		3670		3670	
Coil Face Area (ft ²)	16.08		22.36		22.36		18.30	
Coil Rows - fins per inch	1 - 25		1 - 25		1 - 25		2 - 20	
Low Pressure Switch	23 ± 5		23 ± 5		23 ± 5		23 ± 5	
Open Pressure (psig)	55 ± 5		55 ± 5		55 ± 5		55 ± 5	
Close Pressure (psig)	610 ± 10		610 ± 10		610 ± 10		610 ± 10	
High Pressure Switch	420 ± 25		420 ± 25		420 ± 25		420 ± 25	
Open Pressure (psig)	610 ± 10		610 ± 10		610 ± 10		610 ± 10	
Close Pressure (psig)	420 ± 25		420 ± 25		420 ± 25		420 ± 25	
Liquid Line Connection Size (in.)	3/8		3/8		3/8		3/8	
Vapor Line Connection Size (in.)	3/4		7/8		7/8		7/8	
Recommended Line Set	3/8		3/8		3/8		3/8	
Liquid Tube Diameter (in.)	3/4 *		7/8 *		7/8 *		1 1/8*	
Recommended Line Set	3/4 *		7/8 *		7/8 *		1 1/8*	
Vapor Tube Diameter (in.) *	* Recommended Vapor Tube Line size is for standard installations. These recommendations may not apply to "Long Line" installations. When the total equivalent line length exceeds 80 feet or there is more than 20 feet vertical separation between indoor and outdoor units, consult the Long Line Application Guideline document before purchasing/installing line sets.							
Factory Charge R-410A (lbs.)	5.85		7.13		8.40		9.35	
Required Subcooling (°F)	12		12		13		12	
Weight, shipping (lbs.)	215		282		285		299	
Weight, operating (lbs.)	187		248		251		265	

ELECTRICAL DATA								
Model Size	36GH	36GL	42GH	42GL	48GH	48GL	60GH	60GL
Supply Voltage, 3-phase 60 Hz.	208/230	460	208/230	460	208/230	460	208/230	460
Acceptable Voltage Range, min-max	197-253	414-506	197-253	414-506	197-253	414-506	197-253	414-506
Minimum Circuit Ampacity - MCA (amps)	15.2	7.8	17.9	8.2	18.7	8.4	22.7	10.3
Maximum OverCurrent Protective device - MOCP (amps)	20	15	25	15	30	15	35	15
Compr. RLA (Rated Load Amps)	11.3	5.8	13.5	7.1	13.8	6.2	17	7.8
LRA (Locked Rotor Amps)	73	38	83.1	41	83.1	41	110	52
Fan Motor FLA (Full Load Amps)	1.1	0.6	1.1	0.6	1.4	0.6	1.4	0.6

R-410A COOLING CAPACITY LOSS FOR VARIOUS LINE LENGTHS & TUBE DIAMETERS

Model Size	Liquid Line (in.)	Acceptable Vapor Line Sizes (in.)	Cooling Capacity Loss (%) at Total Equivalent Line Length (ft.) Refer to Long Line Application Guideline to calculate equivalent length										
			Standard Application			Long Line Application (Requires Accessories)							
			25'	50'	80'	81'	100'	125'	150'	175'	200'	225'	250'
36	3/8	5/8	1	2	4	4	5	6	7	9	10	11	13
		3/4	0	0	1	1	1	2	2	3	3	4	4
		7/8	0	0	0	0	0	1	1	1	1	2	2
42		3/4	0	1	2	2	2	3	4	4	5	6	6
		7/8	0	0	1	1	1	1	2	2	2	3	3
48		3/4	0	1	2	2	3	4	5	5	6	7	8
		7/8	0	0	1	1	1	2	2	2	3	3	4
60		3/4	1	2	4	4	5	6	7	9	10	11	12
		7/8	0	1	2	2	2	3	4	4	5	5	6
	1 1/8	0	0	0	0	1	1	1	1	1	1	2	

* Applications are considered “Long Line” if the total equivalent tubing length exceeds 80 feet or there is more than 20 foot vertical separation between indoor and outdoor units). These applications require additional accessories and system modifications for reliable system operation.

Applications in shaded area may have height restrictions that limit allowable total equivalent length when outdoor unit is below indoor unit.

ACCESSORY USAGE GUIDELINES

Accessory	REQUIRED FOR LOW-AMBIENT APPLICATIONS (Below 55° F)	REQUIRED FOR LONG LINE APPLICATIONS* (Over 80 Ft.)
Evaporator Freeze Thermostat	Yes	No
Winter Start Control	Yes	No
Support Feet, 4” tall	Recommended	No
Liquid Line Solenoid Valve	No	See Long-Line Application Guideline

* For Line Set lengths between 80 and 200 ft horizontal, or more than 20 ft indoor-outdoor vertical separation, refer to the Long Line Application Guideline document.

ACCESSORIES

Part Number	Description	Used On Model Size
NASA001FS	Evaporator Freeze Thermostat	ALL
NASA401LS	Liquid Line Solenoid Valve, R-410A	ALL
NASA001TD	Time Delay Relay, Indoor Blower	ALL
NASA001WS	Winter Start Control	ALL
NASA001AC	Anti-Cycle Timer (5 minute delay)	ALL
NASA001SF	Support Feet, 4” tall	ALL
EBAC06TXVX	TXV Kit, R-410A *	36, 42
EBAC07TXVX	TXV Kit, R-410A *	48, 60

* ONLY converts Fan Coils equipped with factory installed R-22 TXV.

COOLING PERFORMANCE FOR COMBINATION RATINGS									
Current Indoor Models									
Outdoor Model	Current Indoor Model (‡ tested combo)	Furnace Model	Factory Installed	Cooling (95 °F)			SEER		
				BTU/hr	S/T	EER	factory	w/ field TDR	w/ field R-410A TXV
H4A336GHB H4A336GLB	‡ED*4X36F**	†	TXV	34,800	0.77	11		13.00	
	ED*4X36B**	†	TXV	34,800	0.77	11.00		13.00	
	ED*4X36B**	MV08B15****	TDR&TXV	34,800	0.77	11.20	13.50		
	ED*4X36F**	*8MPV075	TDR&TXV	34,800	0.77	11.20	13.50		
	ED*4X36F**	*9MPV050	TDR&TXV	34,400	0.77	11.00	13.20		
	ED*4X36F**	*9MPV075	TDR&TXV	34,600	0.77	11.00	13.20		
	^ED*4X36F**	MV12F19****	TDR&TXV	35,000	0.77	11.50	14.00		
	ED*4X36J**	†	TXV	35,000	0.77	11.00		13.00	
	^ED*4X36J**	*8MPV100	TDR&TXV	35,200	0.77	11.50	14.00		
	^ED*4X36J**	*8MPV125	TDR&TXV	35,200	0.77	11.50	14.00		
	ED*4X36J**	*9MPV100	TDR&TXV	35,200	0.77	11.20	13.50		
	^ED*4X36J**	MV16J22****	TDR&TXV	35,000	0.77	11.70	14.50		
	ED*4X42F**	†	TXV	35,400	0.77	11.00		13.20	
	^ED*4X42F**	*8MPV075	TDR&TXV	35,400	0.77	11.50	14.00		
	ED*4X42F**	*9MPV050	TDR&TXV	35,000	0.77	11.20	13.50		
	ED*4X42F**	*9MPV075	TDR&TXV	35,000	0.77	11.50	13.50		
	^ED*4X42F**	MV12F19****	TDR&TXV	36,000	0.77	11.70	14.00		
	ED*4X42J**	†	TXV	35,200	0.77	11.00		13.00	
	^ED*4X42J**	*8MPV100	TDR&TXV	35,400	0.77	11.50	14.00		
	^ED*4X42J**	*8MPV125	TDR&TXV	35,400	0.77	11.50	14.00		
	ED*4X42J**	*9MPV100	TDR&TXV	35,400	0.77	11.20	13.50		
	^ED*4X42J**	MV16J22****	TDR&TXV	35,200	0.77	11.50	14.00		
	ED*4X42L**	†	TXV	35,200	0.77	11.00		13.00	
	^ED*4X42L**	*9MPV125	TDR&TXV	35,000	0.77	11.50	14.00		
	EHD4X36A**	†	TXV	35,000	0.77	11.00		13.00	
	EHD4X36A**	*8MPV050	TDR&TXV	34,800	0.77	11.20	13.50		
	EHD4X36A**	*8MPV075	TDR&TXV	34,800	0.77	11.20	13.50		
	^EHD4X36A**	*8MPV100	TDR&TXV	35,000	0.77	11.50	14.00		
	^EHD4X36A**	*8MPV125	TDR&TXV	35,800	0.77	11.50	14.00		
	EHD4X36A**	*9MPV050	TDR&TXV	34,400	0.77	11.20	13.50		
	EHD4X36A**	*9MPV075	TDR&TXV	34,600	0.77	11.20	13.50		
	^EHD4X36A**	*9MPV100	TDR&TXV	34,800	0.77	11.50	14.00		
	^EHD4X36A**	*9MPV125	TDR&TXV	35,000	0.77	11.50	14.00		
	^EHD4X36A**	MV08B15****	TDR&TXV	35,000	0.77	11.50	14.00		
	EHD4X42A**	†	TXV	35,200	0.77	11.00		13.00	
	EHD4X42A**	*8MPV050	TDR&TXV	35,200	0.77	11.20	13.50		
	^EHD4X42A**	*8MPV075	TDR&TXV	35,400	0.77	11.50	14.00		
	^EHD4X42A**	*8MPV100	TDR&TXV	35,400	0.77	11.50	14.00		
	EHD4X42A**	*9MPV050	TDR&TXV	34,800	0.77	11.20	13.50		
	EHD4X42A**	*9MPV075	TDR&TXV	35,200	0.77	11.20	13.50		
^EHD4X42A**	*9MPV100	TDR&TXV	35,600	0.77	11.50	14.00			
^EHD4X42A**	*9MPV125	TDR&TXV	35,800	0.77	11.50	14.00			
^EHD4X42A**	MV08B15****	TDR&TXV	35,600	0.77	11.50	14.00			
EMA4X36D**	†	TXV	34,800	0.77	11.00		13.00		
^FEM4X36****		TDR&TXV	35,600	0.77	11.50	14.00			
FEM4X36****		TDR&TXV		0.77	12.25				
^FEM4X42****		TDR&TXV	36,000	0.77	11.50	14.00			
FEM4X42****		TDR&TXV		0.77	12.15				
FS(M,U)4X42****		TDR&TXV	35,400	0.77	11.00	13.00			
FSA2X36****		TDR&TXV	34,800	0.77	11.00		13.00		
FSM4X36****		TDR&TXV	35,400	0.77	11.00	13.00			
FSU4X36****		TDR&TXV	34,400	0.77	11.00	13.00			
^FVM4X36****		TDR&TXV	34,800	0.77	12.00	14.00			
^FVM4X48****		TDR&TXV	36,000		12.50	14.00			

^ Indicates ENERGY STAR compliance for combinations with both: SEER 14.0 or higher and EER 11.5 or higher.

‡ For coils not listed with a matching furnace or blower, coil rating applies with any indoor blower device.

- continued on next page -

COOLING PERFORMANCE FOR COMBINATION RATINGS (continued)											
Current Indoor Models											
Outdoor Model	Current Indoor Model (‡ tested combo)	Furnace Model	Factory Installed	Cooling (95 ° F)			SEER				
				BTU/hr	S/T	EER	factory	w/ field TDR	w/ field R-410A TXV	w/ field R-410A TXV+TDR	
H4A342GHB H4A342GLB	ED*4X42F**	†	TXV	42,000	0.75	11.00		13.00			
	ED*4X42F**	*8MPV075	TDR&TXV	41,500	0.75	11.20	13.50				
	ED*4X42F**	*9MPV075	TDR&TXV	41,000	0.75	11.00	13.20				
	‡ED*4X42J**	†	TXV	42,000	0.75	11		13.00			
	^ED*4X42J**	*8MPV100	TDR&TXV	42,000	0.75	11.50	14.00				
	^ED*4X42J**	*8MPV125	TDR&TXV	42,000	0.75	11.50	14.00				
	ED*4X42J**	*9MPV100	TDR&TXV	42,000	0.75	11.20	13.50				
	^ED*4X42J**	MV16J22****	TDR&TXV	42,500	0.75	11.50	14.00				
	ED*4X42L**	†	TXV	42,000	0.75	11.00		13.00			
	ED*4X42L**	*9MPV125	TDR&TXV	42,500	0.75	11.00	13.20				
	ED*4X48F**	†	TXV	43,000	0.75	11.00		13.00			
	ED*4X48F**	*8MPV075	TDR&TXV	43,000	0.75	11.20	13.50				
	ED*4X48J**	†	TXV	42,500	0.75	11.00		13.00			
	^ED*4X48J**	*8MPV100	TDR&TXV	42,500	0.75	11.50	14.00				
	^ED*4X48J**	*8MPV125	TDR&TXV	43,000	0.75	11.50	14.00				
	ED*4X48J**	*9MPV100	TDR&TXV	43,000	0.75	11.00	13.20				
	ED*4X48L**	†	TXV	42,500	0.75	11.00		13.00			
	^ED*4X48L**	*9MPV125	TDR&TXV	43,000	0.75	11.50	14.00				
	EMA4X48D**	†	TXV	42,000	0.75	11.00		13.00			
	EHD4X42A**	†	TXV	42,000	0.75	11.00		13.00			
	EHD4X42A**	*8MPV075	TDR&TXV	42,000	0.75	11.20	13.50				
	EHD4X42A**	*8MPV100	TDR&TXV	42,500	0.75	11.20	13.50				
	^EHD4X42A**	*8MPV125	TDR&TXV	42,000	0.75	11.50	14.00				
	EHD4X42A**	*9MPV100	TDR&TXV	42,000	0.75	11.20	13.50				
	EHD4X42A**	*9MPV125	TDR&TXV	42,000	0.75	11.20	13.50				
	^EHD4X42A**	MV20N26****	TDR&TXV	42,000	0.75	11.50	14.00				
	EHD4X48A**	†	TXV	43,000	0.75	11.00		13.00			
	EHD4X48A**	*8MPV075	TDR&TXV	43,000	0.75	11.20	13.50				
	^EHD4X48A**	*8MPV100	TDR&TXV	42,500	0.75	11.50	14.00				
	^EHD4X48A**	*8MPV125	TDR&TXV	43,000	0.75	11.50	14.00				
	EHD4X48A**	*9MPV100	TDR&TXV	43,000	0.75	11.20	13.50				
	EHD4X48A**	*9MPV125	TDR&TXV	43,000	0.75	11.20	13.50				
	^EHD4X48A**	MV20N26****	TDR&TXV	43,500	0.75	11.50	14.00				
	FS(M,U)4X42****			TDR&TXV	42,000	0.75	11.00	13.00			
	FS(M,U)4X48****			TDR&TXV	43,000	0.75	11.00	13.20			
	FSM4X36****			TDR&TXV	42,500	0.75	11.00	13.00			
	^FEM4X42****			TDR&TXV	43,000	0.75	11.50	14.00			
	^FVM4X48****			TDR&TXV	43,500	0.75	12.00	14.00			
	^FVM4X60****			TDR&TXV	44,000	0.75	12.50	14.00			
	FEM4X42****			TDR&TXV		0.75	12.10				
FEM4X48****			TDR&TXV		0.75	12.55					

^ Indicates ENERGY STAR compliance for combinations with both: SEER 14.0 or higher and EER 11.5 or higher.

‡ For coils not listed with a matching furnace or blower, coil rating applies with any indoor blower device.

- continued on next page -

COOLING PERFORMANCE FOR COMBINATION RATINGS (continued)										
Current Indoor Models										
Outdoor Model	Current Indoor Model († tested combo)	Furnace Model	Factory Installed	Cooling (95 °F)			SEER			
				BTU/hr	S/T	EER	factory	w/ field TDR	w/ field R-410A TXV	w/ field R-410A TXV+TDR
H4A348GHB H4A348GLB	‡ED*4X48J**	†	TXV	47,000	0.76	11		13.00		
	ED*4X48F**	†	TXV	46,500	0.76	11.00		13.00		
	ED*4X48J**	*8MPV125	TDR&TXV	47,000	0.76	11.00	13.20			
	ED*4X48J**	MV16J22****	TDR&TXV	47,000	0.76	11.20	13.50			
	ED*4X48L**	†	TXV	47,000	0.76	11.00		13.00		
	ED*4X48L**	*9MPV125	TDR&TXV	46,500	0.76	11.00	13.20			
	ED*4X60J**	†	TXV	48,000	0.76	11.00		13.00		
	ED*4X60J**	*8MPV100	TDR&TXV	48,500	0.76	11.20	13.50			
	ED*4X60J**	*8MPV125	TDR&TXV	47,500	0.76	11.20	13.50			
	ED*4X60J**	*9MPV100	TDR&TXV	48,000	0.76	11.00	13.20			
	^ED*4X60J**	MV16J22****	TDR&TXV	49,000	0.76	11.50	14.00			
	ED*4X60L**	†	TXV	48,000	0.76	11.00		13.00		
	ED*4X60L**	*9MPV125	TDR&TXV	48,000	0.76	11.20	13.50			
	EMA4X48D**	†	TXV	46,000	0.76	11.00		13.00		
	EHD4X48A**	†	TXV	47,000	0.76	11.00		13.00		
	EHD4X48A**	*8MPV100	TDR&TXV	47,000	0.76	11.00	13.20			
	EHD4X48A**	*8MPV125	TDR&TXV	47,000	0.76	11.00	13.20			
	EHD4X48A**	*9MPV125	TDR&TXV	47,000	0.76	11.00	13.20			
	EHD4X48A**	MV16J22****	TDR&TXV	47,000	0.76	11.20	13.50			
	EHD4X48A**	MV20N26****	TDR&TXV	47,000	0.76	11.20	13.50			
	EHD4X60A**	†	TXV	48,000	0.76	11.00		13.00		
	EHD4X60A**	*8MPV100	TDR&TXV	48,500	0.76	11.20	13.50			
	EHD4X60A**	*8MPV125	TDR&TXV	47,500	0.76	11.20	13.50			
	EHD4X60A**	*9MPV125	TDR&TXV	48,000	0.76	11.20	13.50			
	^EHD4X60A**	MV16J22****	TDR&TXV	49,000	0.76	11.50	14.00			
	^EHD4X60A**	MV20N26****	TDR&TXV	49,000	0.76	11.50	14.00			
	FS(M,U)4X48****			TDR&TXV	47,500	0.76	11.00	13.00		
	FS(M,U)4X60****			TDR&TXV	48,000	0.76	11.00	13.00		
	FEM4X48****			TDR&TXV	48,000	0.76	11.20	13.50		
	^FEM4X60****			TDR&TXV	49,000	0.76	11.50	14.00		
	FVM4X48****			TDR&TXV	48,000	0.76	11.20	13.50		
	^FVM4X60****			TDR&TXV	48,500	0.76	12.00	14.00		
H4A360GHB H4A360GLB	‡ED*4X60L**	†	TXV	59,500	0.76	11		13.00		
	ED*4X60J**	†	TXV	59,000	0.76	11.00		13.00		
	ED*4X60J**	*8MPV100	TDR&TXV	58,500	0.76	11.00	13.20			
	ED*4X60J**	MV16J22****	TDR&TXV	59,500	0.76	11.00	13.20			
	ED*4X60L**	*9MPV125	TDR&TXV	57,500	0.76	11.00	13.20			
	EHD4X60A**	†	TXV	59,500	0.76	11.00		13.00		
	EHD4X60A**	*8MPV100	TDR&TXV	58,500	0.76	11.00	13.20			
	EHD4X60A**	*9MPV125	TDR&TXV	57,000	0.76	11.00	13.20			
	EHD4X60A**	MV16J22****	TDR&TXV	59,500	0.76	11.00	13.20			
	EHD4X60A**	MV20N26****	TDR&TXV	59,500	0.76	11.20	13.50			
	FS(M,U)4X60****			TDR&TXV	59,000	0.76	11.00	13.00		
	FEM4X60****			TDR&TXV	60,500	0.76	11.00	13.20		
	FVM4X60****			TDR&TXV	60,000	0.76	11.00	13.50		

^ Indicates ENERGY STAR compliance for combinations with both: SEER 14.0 or higher and EER 11.5 or higher.

† For coils not listed with a matching furnace or blower, coil rating applies with any indoor blower device.



This product has been designed and manufactured to meet ENERGY STAR criteria for energy efficiency when matched with appropriate coil components. However, proper refrigerant charge and proper air flow are critical to achieve rated capacity and efficiency. Installation of this product should follow the manufacturer's refrigerant charging and air flow instructions. Failure to confirm proper charge and airflow may reduce energy efficiency and shorten equipment life.

OUTDOOR UNIT MODEL NUMBER IDENTIFICATION GUIDE (3-phase)											
Digit Position:	1	2	3	4	5, 6	7	8	9	10	11	12
Example Part Number:	H	4	A	3	36	G	H	B	1	0	0
Product Family	REFRIGERANT 2 = R-22 4 = R-410A		TYPE A = Air Conditioner H = Heat Pump	NOMINAL EFFICIENCY 3 = 13 SEER 4 = 14 SEER	NOMINAL CAPACITY 36 = 36,000 BTUH = 3 tons 42 = 42,000 BTUH = 3½ tons 48 = 48,000 BTUH = 4 tons 60 = 60,000 BTUH = 5 tons	FEATURES A = Standard Grille G = Coil Guard Grille	VOLTAGE H = 208/230-3-60 L = 460-3-60	Sales Code	Engineering Revision	Extra Digit	Extra Digit

ACCESSORIES PART NUMBER IDENTIFICATION GUIDE									
Digit Position:	1	2	3	4	5	6, 7	8, 9	10, 11	
Example Part Number:	N	A	S	A	0	01	01	CH	
N = Non-Branded	BRANDING		PRODUCT GROUP A = Accessory	KIT USAGE S = Split System (AC & HP)	MAJOR SERIES A = Original B = 2nd Generation	REFRIGERANT 0 = Generic or Not Applicable 2 = R-22 4 = R-410A	Product Identifier Number	Package Quantity	Type of Kit (Example: CH = Crankcase Heater)