

### 15 SEER, PACKAGE AIR CONDITIONING UNITS, 2 – 5 TONS

#### 208/230–1–60, Single Phase

#### REFRIGERATION CIRCUIT

- Environmentally sound R–410A refrigerant
- Copper tube/aluminum fin condenser and evaporator coils
- Two stage scroll compressors standard on all models

#### EASY TO INSTALL AND SERVICE

- Installs easily on a rooftop or at ground level
- Easy three–panel accessibility for maintenance and installation
- Easily converts to down discharge applications

#### BUILT TO LAST

- Hail guard (3/8" spacing) wire grilles standard on PAD5\*\*000KTP models (2" spacing) wire grilles on non-tin models)
- Direct drive high efficiency ECM blower motor on all models
- Pre–painted steel cabinet
- Vertical condenser fan discharge
- Full perimeter steel base rails
- High and low pressure switches provide added reliability for the compressor
- Crankcase heaters on all models except 2 ton
- All models available with optional factory installed tin–coated copper evaporator coil (These models are identified with letters TP in the 11th and 12th positions in the model number)

#### WARRANTY\*

- 5 year No Hassle Replacement limited warranty for models with tin coated copper evaporator coils
- 5 year parts limited warranty (including compressor and coils)
  - With timely registration, an additional 5 year parts limited warranty (including compressor and coils)

\*Applies to original purchaser/homeowner, some limitations may apply. See warranty certificate for complete details.



As an Energy Star® Partner, International Comfort Products has determined that this product meets the ENERGY STAR® guidelines for energy efficiency.



Use of the AHRI Certified TM Mark indicates a manufacturer's participation in the program. For verification of certification for individual products, go to [www.ahridirectory.org](http://www.ahridirectory.org).

#### UNIT PERFORMANCE DATA

Model Number	COOLING				Unit Dimensions Height x Width x Depth Inches (mm)	Operating Weight lbs / kg
	Net Capacity BTU/h High / Low Stage	Standard CFM High / Low Stage	S.E.E.R	E.E.R.		
PAD524000K000C	22,600 / 17,600	800 / 600	15.5	11.4	44 <sup>3</sup> / <sub>4</sub> x48 <sup>3</sup> / <sub>16</sub> x32 <sup>5</sup> / <sub>8</sub> (1137x1224x829)	363 (165)
PAD524000KTP0C	22,600 / 17,600	800 / 600	15.5	11.4	44 <sup>3</sup> / <sub>4</sub> x48 <sup>3</sup> / <sub>16</sub> x32 <sup>5</sup> / <sub>8</sub> (1137x1224x829)	363 (165)
PAD536000K000C	34,600 / 24,400	1200 / 800	15.0	12.0	48 <sup>3</sup> / <sub>4</sub> x48 <sup>3</sup> / <sub>16</sub> x44 <sup>1</sup> / <sub>8</sub> (1238x1224x1121)	447 (203)
PAD536000KTP0C	34,600 / 24,400	1200 / 800	15.0	12.0	48 <sup>3</sup> / <sub>4</sub> x48 <sup>3</sup> / <sub>16</sub> x44 <sup>1</sup> / <sub>8</sub> (1238x1224x1121)	447 (203)
PAD548000K000C	46,000 / 33,400	1600 / 1100	15.0	11.0	50 <sup>3</sup> / <sub>4</sub> x48 <sup>3</sup> / <sub>16</sub> x44 <sup>1</sup> / <sub>8</sub> (1289x1224x1121)	475 (215)
PAD548000KTP0C	46,000 / 33,400	1600 / 1100	15.0	11.0	50 <sup>3</sup> / <sub>4</sub> x48 <sup>3</sup> / <sub>16</sub> x44 <sup>1</sup> / <sub>8</sub> (1289x1224x1121)	475 (215)
PAD560000K000C	57,000 / 40,500	1750 / 1200	14.5	11.0	54 <sup>3</sup> / <sub>4</sub> x48 <sup>3</sup> / <sub>16</sub> x44 <sup>1</sup> / <sub>8</sub> (1391x1224x1121)	526 (239)
PAD560000KTP0C	57,000 / 40,500	1750 / 1200	14.5	11.0	54 <sup>3</sup> / <sub>4</sub> x48 <sup>3</sup> / <sub>16</sub> x44 <sup>1</sup> / <sub>8</sub> (1391x1224x1121)	526 (239)

MODEL NOMENCLATURE											
MODEL SERIES	1	2	3	4	5,6	7,8,9	10	11,12	13	14	15
	P	A	D	5	36	000	K	00	0	C	1
P = Package											
A = Air Conditioner											
D = Standard											
TIER											
3 = 13											
4 = 14											
5 = 15											
SEER											
24 = 24,000 BTUH = 2 Tons											
36 = 36,000 BTUH = 3 Tons											
48 = 48,000 BTUH = 4 Tons											
60 = 60,000 BTUH = 5 Tons											
NOMINAL COOLING CAPACITY											
000 = no factory heat											
NOMINAL HEATING BTUH (input)											
K = 208/230-1-60											
VOLTAGE											
00 = No options											
TP – Tin Plated Evaporator Main Tubes											
FACTORY INSTALLED OPTIONS											
0 = Standard											
FEATURE CODE											
Sales Model Digit											
Engineering Digit											

<b>UNIT SPECIFICATIONS – PAD5</b>				
<b>UNIT SIZE</b>	<b>PAD524</b>	<b>PAD536</b>	<b>PAD548</b>	<b>PAD560</b>
<b>NOMINAL COOLING CAPACITY (ton)</b>	2	3	4	5
<b>OPERATING WEIGHT (lb/kg)</b>	363 / 165	447 / 203	475 / 215	526 / 239
<b>COMPRESSOR</b>	Two-Stage Scroll			
<b>REFRIGERANT (R-410A) QUANTITY (lb/kg)</b>	10.1/4.6	9.5/4.3	15.3/6.9	15.8/7.2
<b>REFRIGERANT METERING DEVICE</b>	TXV			
Size	2 Ton	3 Ton	4 Ton	5 Ton
Part Number	EA36YD129	EA36YD139	EA36YD149	EA36YD159
<b>OUTDOOR FAN</b>				
Nominal CFM	2700	2800	3300	3300
Diameter (in./mm)	22/559	22/559	22/559	22/559
Motor HP (RPM)	1/8 (825)	1/8 (825)	1/4 (1100)	1/3 (1110)
<b>OUTDOOR COIL</b>				
Rows...Fins/in	2...21	2...21	2...21	2...21
Face Area (sq. ft.)	13.6	17.5	19.4	23.3
<b>INDOOR COIL</b>				
Rows...Fins/in	3...17	3...17	3...17	4...17
Face Area (sq. ft.)	3.7	4.7	5.7	5.7
<b>INDOOR BLOWER</b>				
Nominal Low Stage Airflow (CFM)	600	800	1100	1200
Nominal High Stage Airflow (CFM)	800	1200	1600	1750
Blower Wheel Size (in. x in.)	10x10	11x10	11x10	11x10
Blower Wheel Size (mm x mm)	254x254	279x254	279x254	279x254
Motor HP (RPM)	1/2	3/4	1	1
<b>HIGH-PRESSURE SWITCH (psig)</b>				
Cutout	670+/-10			
Reset (Auto)	470+/-25			
<b>HIGH-PRESSURE SWITCH 2 (psig)</b> (Compressor Solenoid)				
Cutout	565+/-15			
Reset (Auto)	455+/-15			
<b>LOSS-OF-CHARGE/LOW-PRESSURE SWITCH</b> (Liquid Line) (psig)				
Cutout	23+/-5			
Reset (Auto)	55+/-5			
<b>RETURN-AIR FILTERS (in.) Throwaway*</b>	20x20x1	24x30x1	24x36x1	24x36x1
<b>RETURN-AIR FILTERS (mm) Throwaway*</b>	508x508x25	610x762x25	610x914x25	610x914x25

\* Recommended filter sizes for field-installed air filter grilles mounted on the wall or ceiling of the conditioned structure. Required filter sizes shown are based on the AHRI (Air Conditioning, Heating, and Refrigeration Institute) rated high stage cooling airflow and a maximum face velocity of 300 ft/minute for throwaway filters or 450 ft/minute for permanent filters. Air filter pressure drop for non-standard filters must not exceed .08 inches water column.

<b>A-WEIGHTED SOUND POWER LEVEL (dBA)</b>								
<b>MODEL PAD5</b>	<b>SOUND RATING</b>	<b>TYPICAL OCTAVE BAND SPECTRUM (without tone adjustment)</b>						
		<b>125</b>	<b>250</b>	<b>500</b>	<b>1000</b>	<b>2000</b>	<b>4000</b>	<b>8000</b>
24	75	58.8	63.5	67.2	66.9	63.7	58.3	50.0
36	75	63.7	63.3	66.8	66.5	64.2	60.3	53.0
48	78	69.9	69.9	71.3	73.4	70.0	66.3	60.1
60	78	67.6	67.6	71.8	75.5	71.0	68.1	59.9

NOTE: Tested in accordance with AHRI Standard 270 (not listed in AHRI).

**Dry Coil Air Delivery\* – Horizontal and Downflow Discharge – Unit PAD524–60**

Unit (Voltage)	Motor Speed	Wire Color		External Static Pressure (IN. W.C.)									
				0.1	0.2	0.3	0.4	0.5	0.6	0.7	0.8	0.9	
PAD524 (208/230-1-60)	Low <sup>1</sup>	Blue	CFM	659	551	440	335	---	---	---	---	---	---
	Med-Low	Pink	CFM	726	625	537	407	---	---	---	---	---	---
	Medium <sup>2</sup>	Red	CFM	907	837	759	679	588	474	343	---	---	---
	Med-High	Orange	CFM	953	870	807	718	652	528	443	---	---	---
	High	Black	CFM	1179	1118	1061	996	942	864	794	718	619	---
PAD536 (208/230-1-60)	Low <sup>1</sup>	Blue	CFM	921	740	448	---	---	---	---	---	---	---
	Med-Low	Pink	CFM	1019	849	603	479	---	---	---	---	---	---
	Medium <sup>2</sup>	Red	CFM	1272	1203	1150	1097	1054	996	937	881	841	---
	Med-High <sup>2</sup>	Orange	CFM	1321	1258	1212	1168	1114	1075	1009	856	904	---
	High	Black	CFM	1478	1426	1387	1334	1292	1247	1212	1148	1108	---
PAD548 (208/230-1-60)	Low <sup>1</sup>	Blue	CFM	1201	1159	1101	1062	1004	957	897	852	793	---
	Med-Low	Pink	CFM	1419	1364	1318	1258	1214	1160	1118	1053	1009	---
	Medium <sup>2</sup>	Red	CFM	1678	1635	1602	1558	1513	1474	1438	1404	1349	---
	Med-High	Orange	CFM	1916	1881	1846	1810	1761	1722	1681	1647	1600	---
	High	Black	CFM	2093	2051	2024	1967	1947	1907	1854	1826	1749	---
PAD560 (208/230-1-60)	Low <sup>1</sup>	Blue	CFM	1320	1256	1211	1142	1096	1028	973	903	835	---
	Med-Low	Pink	CFM	1351	1295	1258	1212	1170	1124	1080	1036	992	---
	Medium <sup>2</sup>	Red	CFM	1824	1782	1742	1711	1673	1641	1607	1563	1490	---
	Med-High	Orange	CFM	2001	1958	1923	1883	1831	1776	1705	1624	1538	---
	High	Black	CFM	2292	2238	2158	2049	1935	1840	1732	1635	1513	---

\* Air delivery values are without air filter and are for dry coil (See PAD5 Wet Coil Pressure Drop Table).

<sup>1</sup> Factory-shipped low stage cooling speed

<sup>2</sup> Factory-shipped high stage cooling speed

**NOTE:** Deduct field-supplied air filter pressure drop and wet coil pressure drop to obtain external static pressure available for ducting.

**FILTER PRESSURE DROP**

FILTER SIZE	CFM																			
	500	600	700	800	900	1000	1100	1200	1300	1400	1500	1600	1700	1800	1900	2000	2100	2200	2300	
	Pressure Drop (inches water column)																			
20 x 24 x 1	---	---	---	---	0.09	0.1	0.11	0.13	0.14	0.15	0.16	---	---	---	---	---	---	---	---	---
24 x 30 x 1	---	---	---	---	---	---	---	0.07	0.08	0.09	0.1	0.11	0.12	0.13	0.14	0.15	0.16	0.17	0.18	---
24 x 36 x 1	---	---	---	---	---	---	---	0.06	0.07	0.07	0.08	0.09	0.09	0.10	0.11	0.12	0.13	0.14	0.14	---

Minimum Filter Requirements:

20 x 24 x 1 = PAD524

24 x 30 x 1 = PAD536

24 x 36 x 1 = PAD548, PAD560

**WET COIL PRESSURE DROP (in wc)**

Unit PAD5	STANDARD CFM (SCFM)															
	600	700	800	900	1000	1100	1200	1300	1400	1500	1600	1700	1800	1900	2000	2100
24	0.005	0.007	0.010	0.012	0.015	-	-	-	-	-	-	-	-	-	-	-
36	-	-	-	0.019	0.023	0.027	0.032	0.037	0.042	0.047	-	-	-	-	-	-
48	-	-	-	-	-	-	0.027	0.032	0.036	0.041	0.046	0.052	0.057	0.063	0.068	-
60	-	-	-	-	-	-	-	-	-	-	0.029	0.032	0.036	0.040	0.045	0.049

**Electric Heat Pressure Drop Table (in wc) – Small Cabinet: 24**

CFM	500	600	700	800	900	1000	1100	1200	1300	1400	1500	1600
5kw	0.00	0.00	0.00	0.00	0.00	0.00	0.00	0.00	0.02	0.04	0.06	0.07
7.2 kw	0.00	0.00	0.00	0.00	0.00	0.00	0.00	0.02	0.03	0.05	0.07	0.09
10 kw	0.00	0.00	0.00	0.00	0.00	0.00	0.02	0.04	0.06	0.07	0.09	0.10
15 kw	0.00	0.00	0.00	0.02	0.04	0.06	0.08	0.10	0.12	0.14	0.16	0.18

**Electric Heat Pressure Drop Table (in wc) – Large Cabinet 36–60**

CFM	1100	1200	1300	1400	1500	1600	1700	1800	1900	2000	2100	2200	2300	2400	2500
5kw	0.00	0.00	0.00	0.01	0.02	0.03	0.04	0.05	0.06	0.07	0.08	0.09	0.10	0.11	0.12
7.2 kw	0.00	0.00	0.01	0.02	0.03	0.04	0.05	0.06	0.07	0.08	0.09	0.10	0.11	0.12	0.13
10 kw	0.00	0.00	0.01	0.02	0.03	0.04	0.05	0.06	0.07	0.08	0.09	0.10	0.11	0.12	0.13
15 kw	0.00	0.02	0.03	0.04	0.05	0.06	0.07	0.08	0.09	0.10	0.11	0.12	0.13	0.14	0.15
20 kw	0.02	0.03	0.04	0.05	0.06	0.07	0.08	0.09	0.10	0.11	0.12	0.13	0.14	0.15	0.16

ELECTRICAL DATA											
Unit	Nominal V-PH-HZ	Voltage Range		Compressor		OFM	IFM	Electric Heat		Single Point Power Supply	
		Min.	Max.	RLA	LRA	FLA	FLA	Nominal kW 208v/230v	FLA 208v/230v	MCA 208v/230v	MOCP 208v/230v
PAD524	208/230-1-60	187	253	10.3	52	0.9	4.3	-/-	-/-	18.0/18.0	25/25
								3.8/5.0	18.1/20.8	27.9/31.4	30/35
								5.4/7.2	26.0/30.0	37.9/42.9	40/45
								7.5/10.0	36.1/41.7	50.5/57.5	60/60
PAD536	208/230-1-60	187	253	16.7	82	0.9	6.8	-/-	-/-	28.5/28.2	45/45
								3.8/5.0	18.1/20.8	31.1/34.5	45/45
								5.4/7.2	26.0/30.0	41.0/46.0	45/50
								7.5/10.0	36.1/41.7	53.6/60.6	60/70
PAD548	208/230-1-60	187	253	21.2	96	1.5	6.8	-/-	-/-	34.7/34.7	50/50
								3.8/5.0	18.1/20.8	34.7/34.7	50/50
								5.4/7.2	26.0/30.0	41.0/46.0	50/50
								7.5/10.0	36.1/41.7	53.6/60.6	60/70
PAD560	208/230-1-60	187	253	25.6	118	1.9	9.1	-/-	-/-	43.1/43.1	60/60
								3.8/5.0	18.1/20.8	43.1/43.1	60/60
								5.4/7.2	26.0/30.0	43.9/48.9	60/60
								7.5/10.0	36.1/41.7	56.5/63.5	60/70
								11.3/15.0	54.2/62.5	79.1/89.5	80/90
								15.0/20.0	72.2/83.3	101.6/115.5	110/125

LEGEND

- FLA = Full Load Amps
- LRA = Locked Rotor Amps
- MCA = Minimum Circuit Ampacity
- MOCP = Maximum Overcurrent Protection
- RLA = Rated Load Amps



1. In compliance with NEC (National Electrical Code) requirements for multimotor and combination load equipment (refer to NEC Articles 430 and 440), the overcurrent protective device for the unit shall be Power Supply fuse. The CGA (Canadian Gas Association) units may be fuse or circuit breaker.
2. Minimum wire size is based on 60 C copper wire. If other than 60 C wire is used, or if length exceeds wire length in table, determine size from NEC.

**PAD524 EXTENDED COOLING PERFORMANCE – HIGH COOL**

**CONDENSER ENTERING AIR TEMPERATURES deg F**

EVAPORATOR AIR		75 (23.8 °C)						85 (29.4 °C)						95 (35 °C)						105 (40.5 °C)						115 (46.1 °C)						125 (51.6 °C)					
		CFM		Capacity MBtuh		Total System KW	Capacity MBtuh		Total System KW	Capacity MBtuh		Total System KW	Capacity MBtuh		Total System KW	Capacity MBtuh		Total System KW	Capacity MBtuh		Total System KW	Capacity MBtuh		Total System KW	Capacity MBtuh		Total System KW										
				Total	Sens		Total	Sens		Total	Sens		Total	Sens		Total	Sens		Total	Sens		Total	Sens		Total	Sens		Total	Sens	Total	Sens	Total	Sens				
700	57	21.77	21.77	1.61	20.88	1.79	19.95	19.95	2.00	18.94	18.94	2.23	17.86	17.86	2.48	16.66	16.66	2.77																			
	62	22.40	18.69	1.61	21.29	1.80	20.13	17.70	2.00	18.95	18.95	2.23	17.86	17.86	2.48	16.66	16.66	2.77																			
	63	22.85	15.18	1.62	21.71	1.80	20.52	14.21	2.01	19.25	13.70	2.23	17.90	13.16	2.48	16.42	12.58	2.77																			
	67	24.66	15.72	1.64	23.44	1.83	22.15	14.75	2.03	20.79	14.24	2.26	19.34	13.70	2.51	17.74	13.12	2.79																			
	72	27.16	12.75	1.67	25.83	1.86	24.42	11.80	2.06	22.94	11.29	2.29	21.33	10.76	2.54	19.57	10.18	2.83																			
	57	22.76	22.76	1.64	21.81	1.82	20.81	20.81	2.03	19.74	19.74	2.26	18.58	18.58	2.51	17.29	17.29	2.80																			
	62	22.97	20.16	1.64	21.84	1.82	20.81	20.81	2.03	19.74	19.74	2.26	18.58	18.58	2.51	17.29	17.29	2.80																			
800	63	23.39	16.20	1.64	22.19	1.83	20.94	15.21	2.03	19.62	14.69	2.26	18.22	14.14	2.51	16.69	13.54	2.79																			
	67	25.22	16.81	1.67	23.94	1.85	22.60	15.82	2.05	21.18	15.30	2.28	19.67	14.74	2.53	18.01	14.14	2.82																			
	72	27.77	13.43	1.70	26.37	1.88	24.90	12.48	2.09	23.35	11.95	2.31	21.66	11.41	2.57	20.80	11.05	2.57																			

**PAD524 EXTENDED COOLING PERFORMANCE – LOW COOL**

**CONDENSER ENTERING AIR TEMPERATURES deg F**

EVAPORATOR AIR		75 (23.8 °C)						85 (29.4 °C)						95 (35 °C)						105 (40.5 °C)						115 (46.1 °C)						125 (51.6 °C)					
		CFM		Capacity MBtuh		Total System KW	Capacity MBtuh		Total System KW	Capacity MBtuh		Total System KW	Capacity MBtuh		Total System KW	Capacity MBtuh		Total System KW	Capacity MBtuh		Total System KW	Capacity MBtuh		Total System KW	Capacity MBtuh		Total System KW										
				Total	Sens		Total	Sens		Total	Sens		Total	Sens		Total	Sens		Total	Sens		Total	Sens		Total	Sens		Total	Sens	Total	Sens	Total	Sens				
525	57	16.65	16.65	1.05	15.95	1.20	15.21	15.21	1.37	14.40	14.40	1.57	13.52	13.52	1.80	12.55	12.55	2.07																			
	62	17.20	14.47	1.06	16.29	1.21	15.34	13.65	1.37	14.40	14.40	1.57	13.52	13.52	1.80	12.55	12.55	2.07																			
	63	17.61	11.75	1.06	16.69	1.21	15.70	10.96	1.38	14.64	10.53	1.57	13.50	10.07	1.80	12.27	9.58	2.06																			
	67	19.23	12.26	1.08	18.23	1.22	17.18	11.47	1.39	16.05	11.03	1.58	14.83	10.58	1.81	13.50	10.09	2.07																			
	72	21.48	10.05	1.09	20.41	1.24	19.26	9.26	1.41	18.02	8.84	1.60	16.69	8.39	1.83	15.24	7.90	2.09																			
	57	17.52	17.52	1.08	16.77	1.23	15.96	15.96	1.39	15.10	15.10	1.59	14.15	14.15	1.82	13.11	13.11	2.09																			
	62	17.71	15.66	1.08	16.78	1.23	15.96	15.96	1.39	15.10	15.10	1.59	14.15	14.15	1.82	13.12	13.12	2.09																			
600	63	18.10	12.58	1.08	17.12	1.23	16.09	11.76	1.39	14.98	11.32	1.59	13.80	10.85	1.81	12.51	10.35	2.08																			
	67	19.75	13.14	1.09	18.71	1.24	17.60	12.32	1.41	16.41	11.88	1.60	15.14	11.41	1.83	13.76	10.91	2.09																			
	72	22.06	10.61	1.11	20.93	1.26	19.72	9.80	1.43	18.41	9.36	1.62	17.03	8.91	1.85	15.51	8.41	2.11																			

**PAD536 EXTENDED COOLING PERFORMANCE – HIGH COOL**

CONDENSER ENTERING AIR TEMPERATURES deg F																									
EVAPORATOR AIR		75 (23.8 °C)				85 (29.4 °C)				95 (35 °C)				105 (40.5 °C)				115 (46.1 °C)				125 (51.6 °C)			
CFM	EWB	Capacity MBtuh		Total System KW	Capacity MBtuh		Total System KW	Capacity MBtuh		Total System KW	Capacity MBtuh		Total System KW	Capacity MBtuh		Total System KW	Capacity MBtuh		Total System KW	Capacity MBtuh		Total System KW			
		Total	Sens		Total	Sens		Total	Sens		Total	Sens		Total	Sens		Total	Sens		Total	Sens		Total	Sens	Total
1050	57	33.64	33.64	2.28	32.32	32.32	2.53	30.90	30.90	2.81	29.36	29.36	3.11	27.65	27.65	3.46	25.71	25.71	3.84						
	62	34.47	28.72	2.29	32.83	28.00	2.54	31.11	27.24	2.81	29.36	29.36	3.11	27.65	27.65	3.46	25.71	25.71	3.84						
	63	35.12	23.25	2.29	33.44	22.56	2.54	31.65	21.83	2.81	29.73	21.07	3.12	27.64	20.25	3.45	25.33	19.35	3.83						
	67	37.76	24.04	2.32	35.94	23.34	2.57	34.00	22.61	2.84	31.91	21.83	3.15	29.65	21.00	3.49	27.14	20.10	3.87						
	73	42.16	18.41	2.37	40.12	17.73	2.62	37.93	17.01	2.90	35.58	16.24	3.20	33.02	15.43	3.54	30.21	14.53	3.92						
	57	35.06	35.06	2.32	33.64	33.64	2.58	32.12	32.12	2.85	30.46	30.46	3.16	28.63	28.63	3.50	26.56	26.56	3.89						
	62	35.29	30.91	2.33	33.64	33.64	2.58	32.12	32.12	2.85	30.46	30.46	3.16	28.63	28.63	3.50	26.56	26.56	3.89						
1200	63	35.86	24.79	2.33	34.09	24.08	2.58	32.22	23.34	2.85	30.23	22.56	3.15	28.05	21.71	3.49	25.66	20.78	3.87						
	67	38.52	25.68	2.36	36.62	24.97	2.61	34.60	24.22	2.88	32.43	23.43	3.19	30.06	22.57	3.53	27.47	21.64	3.90						
	73	42.99	19.31	2.41	40.85	18.61	2.66	38.57	17.87	2.93	36.13	17.09	3.24	33.48	16.25	3.58	30.56	15.35	3.96						

**PAD536 EXTENDED COOLING PERFORMANCE – LOW COOL**

CONDENSER ENTERING AIR TEMPERATURES deg F																									
EVAPORATOR AIR		75 (23.8 °C)				85 (29.4 °C)				95 (35 °C)				105 (40.5 °C)				115 (46.1 °C)				125 (51.6 °C)			
CFM	EWB	Capacity MBtuh		Total System KW	Capacity MBtuh		Total System KW	Capacity MBtuh		Total System KW	Capacity MBtuh		Total System KW	Capacity MBtuh		Total System KW	Capacity MBtuh		Total System KW	Capacity MBtuh		Total System KW			
		Total	Sens		Total	Sens		Total	Sens		Total	Sens		Total	Sens		Total	Sens		Total	Sens		Total	Sens	Total
745	57	23.27	23.27	1.46	22.34	22.34	1.65	21.31	21.31	1.87	20.19	20.19	2.12	18.95	18.95	2.41	17.58	17.58	2.76						
	62	23.91	20.06	1.46	22.70	19.54	1.65	21.41	18.97	1.87	20.19	20.19	2.12	18.95	18.95	2.41	17.58	17.58	2.76						
	63	24.46	16.28	1.47	23.21	15.77	1.66	21.87	15.23	1.87	20.42	14.65	2.12	18.85	14.03	2.41	17.14	13.96	2.75						
	67	26.63	16.96	1.48	25.29	16.45	1.67	23.85	15.90	1.89	22.28	15.32	2.14	20.58	14.69	2.43	18.72	14.02	2.77						
	72	29.67	13.86	1.51	28.20	13.35	1.70	26.61	12.81	1.91	24.89	12.23	2.16	23.01	11.60	2.45	20.96	10.93	2.79						
	57	24.45	24.45	1.48	23.43	23.43	1.67	22.33	22.33	1.89	21.11	21.11	2.14	19.80	19.80	2.44	18.32	18.32	2.78						
	62	24.61	21.68	1.48	23.43	23.43	1.67	22.33	22.33	1.89	21.12	21.12	2.14	19.80	19.80	2.44	18.32	18.32	2.78						
850	63	25.11	17.42	1.49	23.80	16.89	1.68	22.39	16.34	1.89	20.88	15.74	2.14	19.24	15.10	2.43	17.46	14.42	2.77						
	67	27.33	18.17	1.50	25.92	17.64	1.69	24.40	17.08	1.91	22.76	16.48	2.15	20.99	15.84	2.44	19.06	15.15	2.78						
	72	30.44	14.64	1.53	28.89	14.12	1.71	27.21	13.55	1.93	25.40	12.96	2.17	23.45	12.33	2.46	21.30	11.65	2.80						

**PAD548 EXTENDED COOLING PERFORMANCE – HIGH COOL**

**CONDENSER ENTERING AIR TEMPERATURES deg F**

EVAPORATOR AIR		75 (23.8 °C)						85 (29.4 °C)						95 (35 °C)						105 (40.5 °C)						115 (46.1 °C)						125 (51.6 °C)					
		Capacity MBtuh		Total System KW		Capacity MBtuh		Total System KW		Capacity MBtuh		Total System KW		Capacity MBtuh		Total System KW		Capacity MBtuh		Total System KW		Capacity MBtuh		Total System KW		Capacity MBtuh		Total System KW									
		Total	Sens	Total	Sens	Total	Sens	Total	Sens	Total	Sens	Total	Sens	Total	Sens	Total	Sens	Total	Sens	Total	Sens	Total	Sens	Total	Sens	Total	Sens	Total	Sens								
<b>1400</b>	CFM	57	44.39	44.39	3.40	42.70	42.70	3.71	40.87	40.87	4.05	38.88	38.88	4.43	36.67	36.67	4.84	34.16	34.16	5.30	31.95	31.95	6.00	29.74	29.74	7.00	27.53	27.53	8.00	25.32	25.32						
	EWB	62	45.43	38.20	3.41	43.33	37.29	3.72	41.11	36.31	4.05	38.87	38.87	4.43	36.67	36.67	4.84	34.16	35.30	4.84	35.30	5.30	31.95	35.30	6.00	29.74	35.30	7.00	27.53	35.30	8.00	25.32					
		63	46.29	30.85	3.42	44.11	29.95	3.73	41.79	29.00	4.06	39.28	28.00	4.43	36.54	26.91	4.84	33.51	33.51	5.30	31.95	4.84	33.51	25.73	4.84	33.51	25.73	5.30	31.95	5.30	26.85	5.30	26.85				
		67	50.04	32.01	3.46	47.71	31.11	3.77	45.21	30.16	4.11	42.50	29.14	4.48	41.00	28.60	4.43	36.24	36.24	5.30	31.95	4.43	41.00	28.60	4.43	36.24	26.85	5.30	31.95	5.30	26.85	5.30	26.85				
		72	55.24	25.88	3.53	52.68	24.98	3.84	49.93	24.04	4.18	46.96	23.04	4.55	45.43	22.53	4.52	40.04	40.04	5.30	31.95	4.52	45.43	22.53	4.52	40.04	20.75	5.41	40.04	20.75	5.41	40.04	20.75				
		57	46.32	46.32	3.48	44.10	44.10	3.79	42.54	42.54	4.13	40.41	40.41	4.51	38.04	38.04	4.92	36.62	36.62	5.30	31.95	4.92	38.04	38.04	4.92	36.62	36.62	4.93	36.62	36.62	4.93	36.62	36.62				
		62	46.57	41.09	3.48	44.43	44.43	3.79	42.54	42.54	4.13	41.40	41.40	4.51	38.04	38.04	4.92	36.61	36.61	5.30	31.95	4.92	38.04	38.04	4.92	36.61	36.61	4.93	36.61	36.61	4.93	36.61	36.61				
	63	47.25	32.81	3.49	44.97	31.89	3.80	42.55	30.92	4.13	39.95	29.90	4.50	37.11	28.80	4.91	33.97	27.59	5.30	31.95	4.91	37.11	28.80	4.91	33.97	27.59	5.36	33.97	27.59	5.36	33.97	27.59					
	67	51.07	34.10	3.53	48.62	33.18	3.84	46.00	32.20	4.18	43.19	31.17	4.55	40.12	30.06	4.96	38.36	29.43	5.30	31.95	4.96	40.12	30.06	4.96	38.36	29.43	5.97	40.12	30.06	5.97	40.12	30.06					
	72	56.36	27.17	3.60	53.67	26.25	3.91	50.80	25.29	4.25	47.69	24.26	4.62	44.30	23.15	5.03	42.55	22.59	5.30	31.95	5.03	44.30	23.15	5.03	42.55	22.59	5.06	42.55	22.59	5.06	42.55	22.59					

**PAD548 EXTENDED COOLING PERFORMANCE – LOW COOL**

**CONDENSER ENTERING AIR TEMPERATURES deg F**

EVAPORATOR AIR		75 (23.8 °C)						85 (29.4 °C)						95 (35 °C)						105 (40.5 °C)						115 (46.1 °C)						125 (51.6 °C)					
		Capacity MBtuh		Total System KW		Capacity MBtuh		Total System KW		Capacity MBtuh		Total System KW		Capacity MBtuh		Total System KW		Capacity MBtuh		Total System KW		Capacity MBtuh		Total System KW		Capacity MBtuh		Total System KW									
		Total	Sens	Total	Sens	Total	Sens	Total	Sens	Total	Sens	Total	Sens	Total	Sens	Total	Sens	Total	Sens	Total	Sens	Total	Sens	Total	Sens	Total	Sens	Total	Sens								
<b>965</b>	CFM	57	31.49	31.49	2.22	30.30	30.30	2.49	29.02	29.02	2.78	27.63	27.63	3.12	26.10	26.10	3.51	24.40	24.40	3.96	22.19	22.19	4.50	20.98	20.98	5.00	19.57	19.57	5.50	18.16	18.16						
	EWB	62	32.49	27.41	2.21	30.96	26.74	2.48	29.34	26.03	2.78	27.64	27.57	3.12	26.10	26.10	3.51	24.40	24.40	3.97	22.19	22.19	4.50	20.98	20.98	5.00	19.57	20.98	5.50	18.16	20.98	5.50	18.16				
		63	33.19	22.28	2.21	31.62	21.62	2.48	29.95	20.92	2.78	28.14	20.18	3.12	26.19	19.39	3.52	24.04	18.53	3.97	22.19	22.19	4.50	20.98	20.98	5.00	19.57	24.04	18.53	3.97	22.19	22.19					
		67	36.14	23.21	2.21	34.45	22.54	2.47	32.65	21.84	2.77	30.72	21.10	3.10	28.62	20.30	3.49	26.31	19.44	3.94	22.19	22.19	4.50	20.98	20.98	5.00	19.57	26.31	19.44	3.94	22.19	22.19					
		72	40.19	19.02	2.21	38.34	18.36	2.46	36.37	17.67	2.75	34.25	16.93	3.08	31.95	16.14	3.46	29.40	15.29	3.90	22.19	22.19	4.50	20.98	20.98	5.00	19.57	29.40	15.29	3.90	22.19	22.19					
		57	33.04	33.04	2.24	31.76	31.76	2.50	30.39	30.39	2.80	28.90	28.90	3.13	27.27	27.27	3.52	25.45	25.45	3.97	22.19	22.19	4.50	20.98	20.98	5.00	19.57	25.45	25.45	3.97	22.19	22.19					
		62	33.42	29.57	2.23	31.85	28.86	2.50	30.39	30.39	2.80	28.90	28.90	3.13	27.27	27.27	3.52	25.45	25.45	3.97	22.19	22.19	4.50	20.98	20.98	5.00	19.57	25.45	25.45	3.97	22.19	22.19					
<b>1100</b>		63	34.05	23.76	2.23	32.40	23.08	2.50	30.64	22.37	2.80	28.77	21.61	3.14	26.73	20.81	3.53	24.50	19.92	3.99	22.19	22.19	4.50	20.98	20.98	5.00	19.57	24.50	19.92	3.99	22.19	22.19					
		67	37.06	24.78	2.23	35.29	24.10	2.49	33.40	23.38	2.78	31.39	22.62	3.12	29.20	21.81	3.51	26.79	20.93	3.95	22.19	22.19	4.50	20.98	20.98	5.00	19.57	26.79	20.93	3.95	22.19	22.19					
		72	41.21	20.03	2.23	39.26	19.35	2.48	37.19	18.64	2.77	34.96	17.88	3.10	32.54	17.07	3.48	29.89	16.19	3.92	22.19	22.19	4.50	20.98	20.98	5.00	19.57	29.89	16.19	3.92	22.19	22.19					



**PAD560 EXTENDED COOLING PERFORMANCE – HIGH COOL**

EVAPORATOR AIR		CONDENSER ENTERING AIR TEMPERATURES deg F																	
		75 (23.8°C)			85 (29.4°C)			95 (35°C)			105 (40.5°C)			115 (46.1°C)			125 (51.6°C)		
		CFM	EWB	Capacity MBtuh Total	Sens	Total System KW	Capacity MBtuh Total	Sens	Total System KW	Capacity MBtuh Total	Sens	Total System KW	Capacity MBtuh Total	Sens	Total System KW	Capacity MBtuh Total	Sens	Total System KW	
2000	57	58.24	58.24	4.41	55.10	55.10	4.84	54.80	54.80	4.69	52.40	52.40	5.23	46.70	46.70	6.40	42.90	42.90	7.02
	62	58.46	54.46	4.42	55.79	55.79	4.84	55.36	55.36	4.69	52.73	52.73	5.23	46.94	46.94	6.40	43.20	43.20	7.02
	63	59.23	43.33	4.42	56.27	42.07	4.85	55.68	41.83	4.69	52.48	40.49	5.22	45.80	37.74	6.37	41.56	36.02	6.97
	67	63.56	44.86	4.50	60.35	43.59	4.92	56.88	42.24	5.38	56.62	42.14	5.33	48.97	39.21	6.44	44.37	37.49	7.05
	72	69.55	35.33	4.59	66.01	34.07	5.02	62.20	32.73	5.48	58.07	31.30	5.99	53.51	29.74	6.54	48.46	28.03	7.15
	57	56.01	56.01	4.29	53.76	53.76	4.72	51.30	51.30	5.19	50.80	50.80	5.08	45.20	45.20	6.27	41.70	41.70	6.89
	62	57.19	50.62	4.31	54.45	49.37	4.73	51.51	48.01	5.19	50.93	47.74	5.08	45.50	45.50	6.27	41.99	41.99	6.89
1750	63	58.18	40.75	4.32	55.35	39.51	4.74	52.28	39.20	5.20	51.66	37.95	5.10	45.27	35.27	6.26	41.16	33.59	6.87
	67	62.48	42.11	4.39	59.41	40.86	4.81	57.00	39.90	5.18	55.71	39.39	5.21	48.47	36.58	6.34	44.00	34.88	6.94
	72	68.41	33.69	4.48	65.01	32.46	4.91	61.35	31.14	5.37	57.37	29.72	5.88	52.97	28.19	6.44	48.09	26.53	7.04

**PAD560 EXTENDED COOLING PERFORMANCE – LOW COOL**

EVAPORATOR AIR		CONDENSER ENTERING AIR TEMPERATURES deg F																	
		75 (23.8°C)			85 (29.4°C)			95 (35°C)			105 (40.5°C)			115 (46.1°C)			125 (51.6°C)		
		CFM	EWB	Capacity MBtuh Total	Sens	Total System KW	Capacity MBtuh Total	Sens	Total System KW	Capacity MBtuh Total	Sens	Total System KW	Capacity MBtuh Total	Sens	Total System KW	Capacity MBtuh Total	Sens	Total System KW	
1200	57	39.88	39.88	2.70	38.34	38.34	3.04	36.64	36.64	3.43	34.74	34.74	3.87	31.90	31.90	4.37	29.70	29.70	4.94
	62	40.94	35.96	2.69	39.01	35.09	3.04	36.90	34.14	3.43	34.90	34.90	3.87	32.60	32.60	4.37	30.16	30.16	4.94
	63	41.76	29.14	2.69	39.78	28.27	3.04	37.61	27.34	3.42	35.23	26.33	3.87	32.61	25.22	4.37	29.69	24.04	4.96
	67	45.04	30.17	2.68	42.87	29.29	3.02	40.50	28.35	3.40	37.91	27.31	3.84	35.04	26.21	4.33	31.84	25.00	4.90
	72	49.59	24.40	2.68	47.18	23.52	3.01	44.52	22.56	3.38	41.68	21.55	3.80	38.47	20.43	4.28	34.93	19.21	4.84
	57	41.69	41.69	2.72	40.00	40.00	3.07	37.90	37.90	3.45	35.45	35.45	3.89	33.62	33.62	4.38	30.90	30.90	4.95
	62	41.98	38.83	2.72	40.02	40.02	3.07	38.18	38.18	3.45	36.13	36.13	3.89	33.82	33.82	4.38	31.19	31.19	4.95
1370	63	42.72	31.09	2.72	40.63	30.20	3.07	38.35	29.24	3.45	35.86	28.21	3.89	33.13	27.09	4.40	30.10	25.87	4.98
	67	46.03	32.23	2.72	43.75	31.34	3.05	41.27	30.36	3.43	38.55	29.32	3.86	35.56	28.18	4.36	32.25	26.93	4.92
	72	50.62	25.68	2.71	48.09	24.78	3.04	45.37	23.83	3.41	42.32	22.77	3.83	39.01	21.64	4.31	35.34	20.40	4.86

\* 63°F Ewb is at 75°F entering dry bulb — Tennessee Valley Authority [TVA] rating conditions; all others at 80°F entering dry bulb.

LEGEND: BF — Bypass Factor Ewb — Entering Wet Bulb kW — Total Unit Power Input SHC — Sensible Heat Capacity (x1000 Btuh) TC — Total Capacity (x1000 Btuh) (net)

NOTES:

1. Ratings are net; they account for the effects of the evaporator fan motor power and heat.
2. Direct interpolation is permissible. Do not extrapolate.
3. The following formulas may be used:

$$t_{Ldb} = t_{Edb} - \frac{\text{Sensible Capacity (BTU/h)}}{1.10 \times \text{cfm}}$$

$$t_{Lwb} = \text{Wet bulb temperature corresponding to enthalpy of air leaving evaporator coil } (h_{Lwb})$$

$$h_{Lwb} = h_{Ewb} - \frac{\text{Total Capacity (BTU/h)}}{4.5 \times \text{cfm}}$$

$$h_{Lwb} = h_{Ewb} - \frac{\text{Total Capacity (BTU/h)}}{4.5 \times \text{cfm}}$$

$$\text{Below } 80^\circ\text{F Edb, subtract (corr factor } \times \text{cfm) from SHC.}$$

$$\text{Above } 80^\circ\text{F Edb, add (corr factor } \times \text{cfm) to SHC. Correction Factor} = 1.10 \times (1 + \text{BF}) \times (\text{Edb} + 80).$$

Where:  $h_{Ewb}$  = Enthalpy of air entering evaporator coil

# UNIT DIMENSIONS - PAD524

PAD5	ELECTRICAL CHARACTERISTICS	UNIT WT.		UNIT HEIGHT IN/MM		CENTER OF GRAVITY IN/MM					
		LB	KG	"A"	X	Y	Z				
24	208/230-1-60	386	175.0	44-3/4	1136.7	20-1/2	520.7	15-3/4	400.1	16-5/8	422.3

PAD5	VOLTAGE	CORNER WEIGHT LB/KG		
		"1"	"2"	"4"
24	208/230	77.2	35.0	61.7
		28.0	92.6	42.0
		154.3	70.1	

**REQUIRED CLEARANCES TO COMBUSTIBLE WALL**

TOP OF UNIT.....42 [1066.8]  
 SIDE OF UNIT.....24 [610.0]  
 SIDE OPPOSITE DUCTS.....24 [610.0]  
 BOTTOM OF UNIT.....0 [0.0]  
 ELECTRICAL PANEL.....36 [914.4]

**REQ. REQUIRED CLEARANCES**

BETWEEN UNITS, POWER ENTRY SIDE.....42 [1066.8]  
 UNIT AND UNGROUND SURFACES, POWER ENTRY SIDE.....36 [914.0]  
 UNIT AND BLOCK OR CONCRETE WALLS AND OTHER UNGROUND SURFACES, POWER ENTRY SIDE.....42 [1066.8]

**REQUIRED CLEARANCE FOR OPERATION AND SERVICING**

FWP, COIL ACCESS SIDE.....42 [1066.8]  
 POWER ENTRY SIDE.....42 [1066.8]  
 (EXCEPT FOR NEC REQUIREMENTS)  
 UNIT TOP.....48 [1219.2]  
 SIDE OPPOSITE DUCTS.....36 [914.0]  
 DUCT PANEL.....12 [304.8]

\*MINIMUM DISTANCES IF UNIT IS PLACED LESS THAN 12.304.8 FROM WALL SYSTEM, THEN SYSTEM PERFORMANCE MAY BE COMPROMISED.

DIMENSIONS IN ( ) ARE IN MILLIMETERS

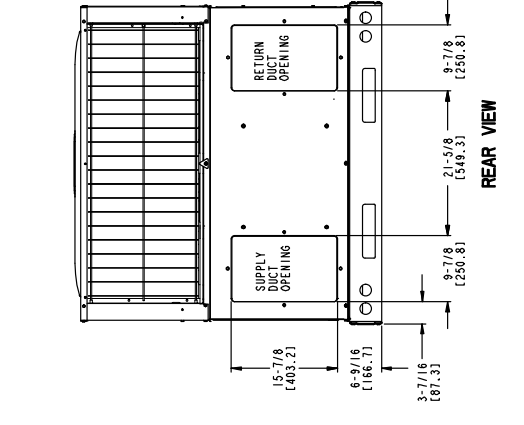
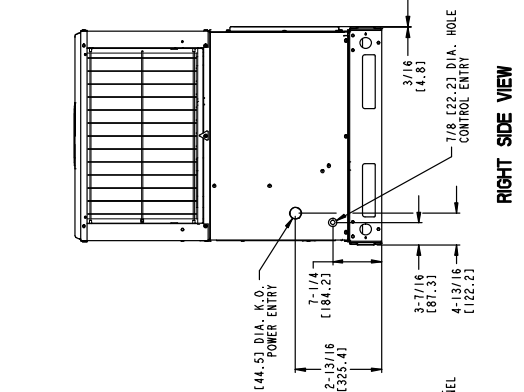
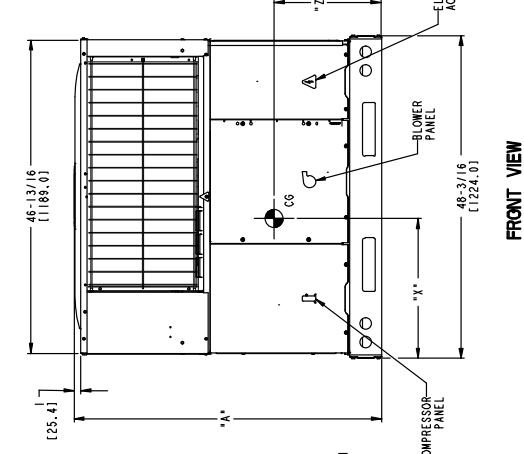
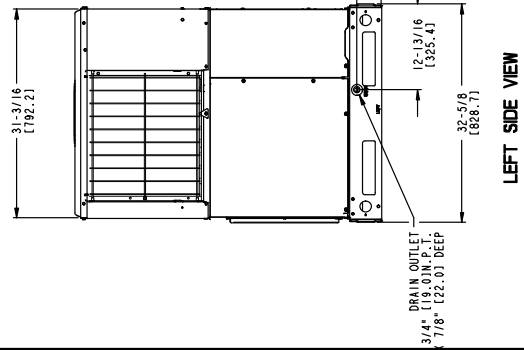
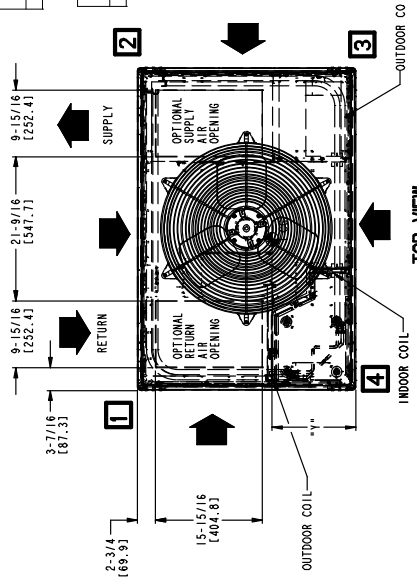

# UNIT DIMENSIONS – PAD536 – 60

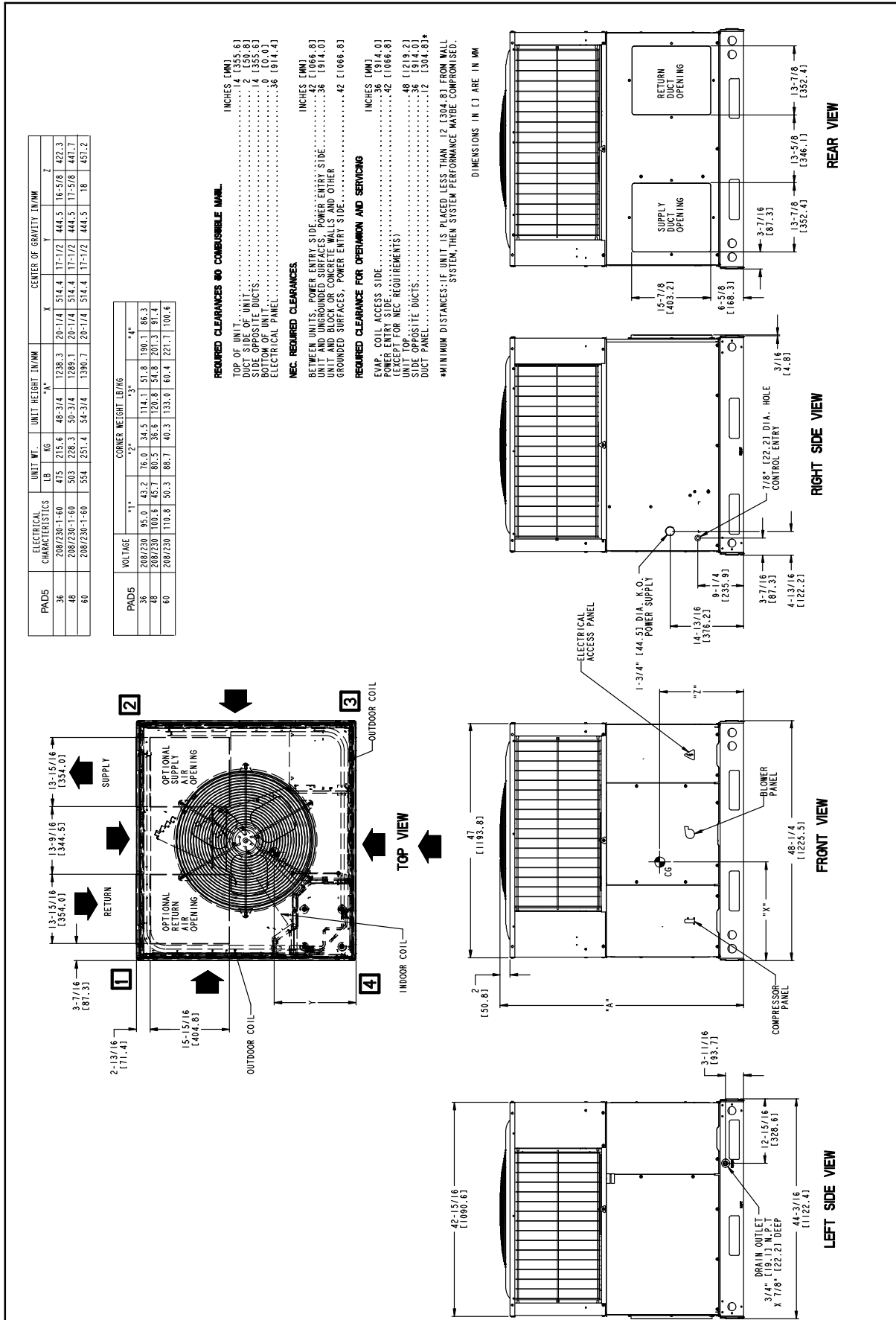





## CONTROLS, OPERATING SEQUENCE

### Operating Sequence

**Cooling Operation** – With a call for first stage cooling, the outdoor fan and low-stage compressor are energized. If low-stage cannot satisfy cooling demand, high-stage is energized by the thermostat. After second stage is satisfied, the unit returns to low-stage operation until first stage is satisfied or until second stage is required again. When both first stage and second stage cooling are satisfied, the compressor will shut off.

**NOTE:** When two-stage unit is operating at low stage, system vapor (suction) pressure will be higher than a standard single-stage system or high-stage operation.

**NOTE:** On units with anti-cycle timer: Once the compressor has started and then stopped, it cannot be restarted again until 5 minutes have elapsed.

**Heating** — If accessory electric heaters are installed, on a call for heat, circuit R-W is made through the thermostat contacts. Circuit R-G is made which energizes the IFR. If the heaters are staged, then the thermostat closes a second set of contacts (W2) when second stage is required. When thermostat is satisfied, contacts open, deenergizing the heater relay and the IFR.

# ACCESSORIES

## ROOF CURBS

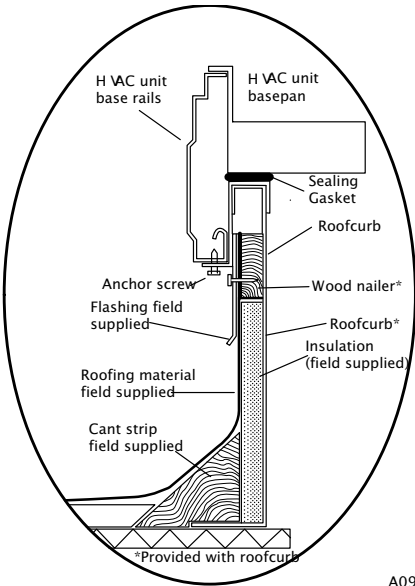

A09090

ROOF CURB DETAIL

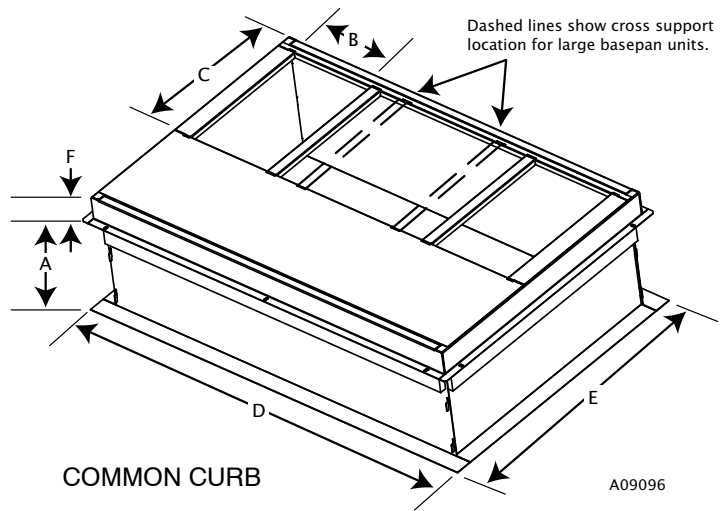

A09096

COMMON CURB

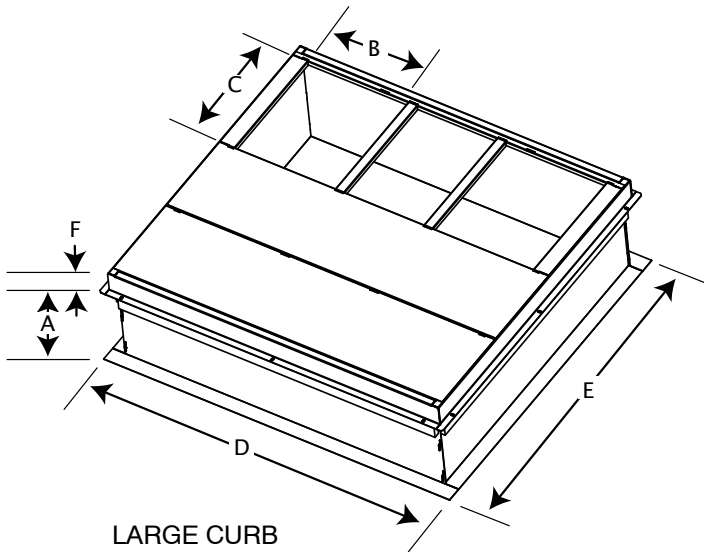

A09095

LARGE CURB

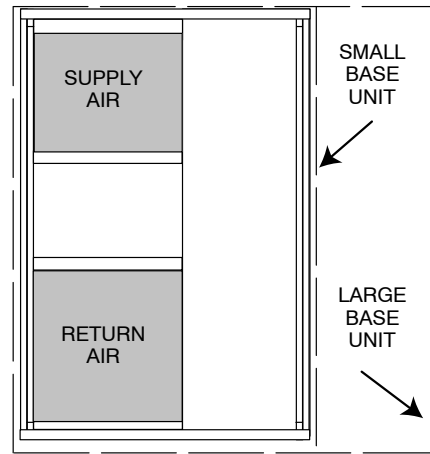

UNIT PLACEMENT ON COMMON CURB

A09094

SMALL OR LARGE BASE UNIT

UNIT SIZE	CATALOG NUMBER	A IN. (mm)	B (small base) IN. (mm)*	B (large base) IN. (mm)*	C IN. (mm)	D IN. (mm)	E IN. (mm)	F IN. (mm)
Small or Large	CPRFCURB010A00	11 (279)	10 (254)	14 (356)	16 (406)	47.8 (1214)	32.4 (822)	2.7 (69)
	CPRFCURB011A00	14 (356)						
Large	CPRFCURB012A00	11 (279)	14 (356)	14 (356)	16 (406)	47.8 (1214)	43.9 (1116)	2.7 (69)
	CPRFCURB013A00	14 (356)						

\* Part Numbers CPRFCURB010A00 and CPRFCURB011A00 can be used on both small and large basepan units. The cross supports must be located based on whether the unit is a small basepan or a large basepan.

NOTES:

1. Roof curb must be set up for unit being installed.
2. Seal strip must be applied, as required, to unit being installed.
3. Roof curb is made of 16-gauge steel.
4. Attach ductwork to curb (flanges of duct rest on curb).
5. Insulated panels: 1-in. (25.4 mm) thick fiberglass 1 lb. density.

PAD5 ACCESSORIES (Continued)						
Accessory Model Number		Description			Use With	
<b>CURBS</b>						
CPRFCURB010A00		Roof Curb, 11" High			24 – 60	
CPRFCURB011A00		Roof Curb, 14" High			24 – 60	
CPRFCURB012A00		Roof Curb, 11" High			36 – 60	
CPRFCURB013A00		Roof Curb, 14" High			36 – 60	
<b>Note: CPRFCURB010A00 AND CPRFCURB011A00 can be used with 36–60 size units with some overhang.</b>						
<b>ADAPTER CURBS*</b>						
CPADCURB001A00		Adapter curb for use with NPRFCURB006A00 & NPRFCURB007A00			24	
CPADCURB002A00		Adapter curb for use with NPRFCURB008A00 & NPRFCURB009A00			36 – 60	
* Can also be used when replacing other manufacturer's older generation units that contain a composite base without a metal base rail.						
<b>CONCENTRIC ADAPTERS – (Use with curb only)</b>						
NPCONADP001A00		For 18" round duct (use with curbs CPRFCURB010A00, CPRFCURB011A00)			Small Curb	
NPCONADP002A00		For 18" round duct (use with curbs CPRFCURB012A00, CPRFCURB013A00)			Large Curb	
<b>CONCENTRIC DIFFUSERS – (Ceiling or under roof)</b>						
AXB020CSA*		Step Down Diffuser – Fits 2' x 4' Ceiling Grid (16" round collars for flex conn.)			24 – 42	
AXB020CFA*		Flush Mount Diffuser – Fits 2' x 4' Ceiling Grid (16" round collars for flex conn.)			24 – 42	
AXB030CSA		Step Down Diffuser – Fits 2' x 4' Ceiling Grid (18" round collars for flex conn.)			24 – 60	
AXB030CFA		Flush Mount Diffuser – Fits 2' x 4' Ceiling Grid (18" round collars for flex conn.)			24 – 60	
* A field supplied 18" to 16" round reducer required when used with NP concentric adaptor						
<b>DAMPERS</b>						
CPMANDPR007A00		Manual Outside Air Damper – (Includes filter rack and 1" filter, same as CPFILTRK kit)			24	
CPMANDPR008A00					36	
CPMANDPR009A00					48, 60	
<b>INTERNAL FILTER RACKS</b>						
CPFILTRK007A00		Internal Filter Rack (includes 1–inch filters)			24	
CPFILTRK008A00					36	
CPFILTRK009A00					48, 60	
<b>LOW AMBIENT, ANTI-CYCLE TIMER, COMPRESSOR START ASSIST</b>						
CPLOWAMB001A00		Low Ambient Control – enables cooling system to operate down to 0 Deg. F by cycling condenser fan on and off.			ALL	
NRTIMEGD001A00		Five Minute Compressor Delay			ALL	
CPHSTART002A00		PTC Compressor Start Assist Kit			ALL	
<b>CRANKCASE HEATERS</b>						
CPCRKHTR0004A00		Crankcase Heater			24	
<b>HAIL GUARDS / COIL PROTECTION (Factory installed on PAD**000KTP models)</b>						
NAPA00701GR		3/8" spacing dense wire grilles			24	
NAPA01001GR		3/8" spacing dense wire grilles			36	
NAPA01101GR		3/8" spacing dense wire grilles			48	
NAPA01301GR		3/8" spacing dense wire grilles			60	
<b>ELECTRIC HEATER USAGE, 208/230–1–60</b>						
Electric Heater Model Number	Nominal Capacity (kW)	Fuses	Used With PAD5 Model Sizes			
			24	36	48	60
EHNA05K0N	5.0	0	✓	✓	✓	✓
EHNA05K4F	5.0	4	✓	✓	✓	✓
EHNA07K0N	7.5	0	✓	✓	✓	✓
EHNA07K4F	7.5	4	✓	✓	✓	✓
EHNA10K0N	10.0	0	✓	✓		
EHNA10K4F	10.0	4	✓	✓	✓	✓
EHNA15K4F	15.0	4		✓		
EHNA15K6F	15.0	6		✓	✓	✓
EHNA20K6F	20.0	6			✓	✓
<b>DUAL POINT WIRING KIT</b>						
CPDUALPT001A00		Dual Point Wiring kit, 5–20kW Heaters			ALL	
<b>DUCT TRANSITIONS</b>						
NPDUCLFG002A00		Square to Round (1 set of 2, use with horizontal duct flanges only)			24–48	

International Comfort Products, LLC  
Lewisburg, Tennessee 37091 USA  
www.GoHeil.com