



14 SEER, 12 EER PACKAGE AIR CONDITIONER, 2 – 5 TONS

Single Phase, 208/230 V, 60 Hz

REFRIGERATION CIRCUIT

- Environmentally sound R-410A refrigerant
- Copper tube/aluminum fin condenser and evaporator coils
- Scroll compressors standard on all models

EASY TO INSTALL AND SERVICE

- Installs easily on a rooftop or at ground level
- Easy single-panel accessibility for maintenance and installation
- Easily converts to down discharge applications

BUILT TO LAST

- Wire grille
- Heavy Duty Pre-painted steel cabinet
- Direct Drive High efficiency X-13 indoor blower motor on all models
- Vertical condenser fan discharge
- Rust-proof base with integral sloping drain
- High and low pressure switches provide added reliability for the compressor

WARRANTY*

- 5 year compressor limited warranty
- 5 year parts limited warranty (including compressor and coils)
 - With timely registration, an additional 5 year parts limited warranty (including compressor and coils)

*Applies to original purchaser/homeowner, some limitations may apply. See warranty certificate for complete details.



As an Energy Star® Partner, International Comfort Products has determined that this product meets the ENERGY STAR® guidelines for energy efficiency.



UNIT PERFORMANCE DATA						
Model Number	COOLING				Unit Dimensions Height x Width x Depth inches (mm)	Operating Weight lbs (kg)
	Nominal Capacity BTU/h	S.E.E.R	E.E.R.	S/T Ratio		
PAN424000K00A	24,000	14.3	12.0	.73	37x48x33 (940x1226x831)	265 (120)
PAN430000K00A	28,400	14.3	12.0	.75	37x48x33 (940x1226x831)	277 (126)
PAN436000K00A	34,200	14.2	12.0	.76	43x48x33 (1093x1226x831)	335 (152)
PAN442000K00A	40,500	14.3	12.0	.75	47x48x44 (1193x1226x1123)	384 (174)
PAN448000K00A	48,000	14.3	12.0	.75	47x48x44 (1193x1226x1123)	402 (182)
PAN460000K00A	59,000	14.0	12.0	.72	51x48x44 (1295x1226x1123)	430 (195)

UNIT SPECIFICATIONS												
MODEL NUMBER	Electrical Data 208/230 - 1 - 60		Condenser									Sound Ratings (dBA)
	Maximum HACR Breaker or Fuse	Minimum Circuit Ampacity	Coil			Fan Motor			Fan			
			Total Face Area (ft. ²)	Fins Per Inch / Rows	Tube Diameter (inch)	Horse Power	Full Load Amps	Locked Rotor Amps	Diameter (inches)	RPM (Max.)	CFM (Design)	
PAN424000K00A	30 amps	21.0	10.2	21 / 2	3/8	1/8	0.9	1.6	22	825	2200	71
PAN430000K00A	30 amps	21.0	10.2	21 / 2	3/8	1/8	0.9	1.6	22	825	2800	73
PAN436000K00A	35 amps	24.5	15.25	21 / 2	3/8	1/8	0.9	1.7	22	825	3000	76
PAN442000K00A	45 amps	29.3	19.4	21 / 2	3/8	1/8	0.9	1.7	22	825	3500	74
PAN448000K00A	50 amps	36.4	19.4	21 / 2	3/8	1/4	1.5	3.2	22	1100	3500	79
PAN460000K00A	60 amps	42.5	23.3	21 / 2	3/8	1/4	1.9	4.0	22	1100	4200	78

MODEL NUMBER	Evaporator								Scroll Compressor		Factory Refrigerant Charge R-410A (lbs)	Shipping Weight lbs/kg
	Coil			Motor		Blower			Rated Load Amps	Locked Rotor Amps		
	Total Face Area (ft. ²)	Fins Per Inch / Rows	Tube Diam. (inch)	HP	Full Load Amps	Size (inches)	RPM (Max)	CFM (Rated)				
PAN424000K00A	3.7	17 / 3	3/8	1/2	4.1	10 x 10	1050	800	12.8	58.3	7.5	319/145
PAN430000K00A	3.7	17 / 3	3/8	1/2	4.1	10 x 10	1050	1000	12.8	64.0	7.8	331/150
PAN436000K00A	3.7	15 / 4	3/8	3/4	6.0	11 x 10	1000	1200	14.1	77.0	9.8	389/176
PAN442000K00A	4.7	17 / 3	3/8	3/4	6.0	11 x 10	1075	1400	17.9	112.0	11.0	446/202
PAN448000K00A	5.7	17 / 3	3/8	1.0	7.6	11 x 10	1075	1600	21.8	117.0	10.5	464/211
PAN460000K00A	5.7	17 / 4	3/8	1.0	7.6	11 x 10	1040	1750	26.4	134.0	14.5	492/223

PRESSURE SWITCHES		
Switch Type	Cut-out Pressure (PSIG)	Reset (automatic) Pressure (PSIG)
High	650 +/- 15	420 +/- 15
Loss of Charge (Low)	20 +/- 5	45 +/- 10

UNIT AIRFLOW, Horizontal and Downflow Discharge, 230 Volts, Dry Coil

Model	Motor Speed	Wire Color	CFM at External Static Pressure (Inches Water Column)								
			0.1	0.2	0.3	0.4	0.5	0.6	0.7	0.8	0.9
PAN424000	Low	Blue	741	638	547	415	--	--	--	--	--
	Med-Low ¹	Pink	898	820	738	662	536	--	--	--	--
	Medium	Red	973	887	823	733	665	538	451	--	--
	Med-High	Orange	1140	1064	996	915	840	758	687	564	480
PAN430000	High	Black	1202	1140	1082	1015	961	881	810	732	631
	Low	Blue	741	638	547	415	--	--	--	--	--
	Med-Low	Pink	898	820	738	662	536	--	--	--	--
	Medium	Red	973	887	823	733	665	538	451	--	--
PAN436000	Med-High ¹	Orange	1140	1064	996	915	840	758	687	564	480
	High	Black	1202	1140	1082	1015	961	881	810	732	631
	Low	Blue	1206	1151	1085	1033	961	901	839	769	694
	Med-Low ¹	Pink	1369	1317	1262	1208	1152	1095	1037	979	919
PAN442000	Medium	Red	1419	1370	1315	1269	1209	1161	1101	1043	984
	Med-High	Orange	1557	1507	1464	1412	1365	1310	1265	1212	1154
	High	Black	1599	1553	1505	1460	1410	1361	1310	1262	1203
	Low	Blue	1295	1234	1182	1126	1075	1016	955	898	857
PAN448000	Med-Low	Pink	1345	1282	1235	1194	1140	1095	1027	974	921
	Medium	Red	1505	1452	1413	1358	1323	1282	1234	1169	1130
	Med-High ¹	Orange	1545	1492	1449	1411	1362	1313	1278	1231	1188
	High	Black	1705	1643	1607	1568	1518	1483	1448	1404	1360
PAN460000	Low	Blue	1445	1389	1341	1281	1236	1189	1139	1072	1027
	Med-Low ¹	Pink	1678	1635	1602	1558	1513	1474	1438	1404	1349
	Medium	Red	1962	1915	1880	1843	1794	1753	1711	1675	1628
	Med-High	Orange	2131	2088	2065	2013	1982	1941	1888	1860	1785
PAN460000	High	Black	2461	2409	2339	2286	2192	2140	2062	1968	1874
	Low	Blue	1448	1362	1296	1226	1168	1108	1071	998	905
	Med-Low	Pink	1722	1675	1614	1543	1499	1442	1408	1356	1308
	Medium ¹	Red	1887	1847	1783	1726	1677	1625	1578	1527	1432
PAN460000	Med-High	Orange	2055	2008	1958	1927	1900	1768	1685	1581	1458
	High	Black	2292	2238	2158	2049	1935	1840	1732	1635	1513

* Air delivery values are without air filter and are for dry coil (See Pressure Drop tables). Deduct field-supplied air filter pressure drop and wet coil pressure drop to obtain external static pressure available for ducting.

1. Factory-shipped cooling speed

FILTER PRESSURE DROP

FILTER SIZE	CFM																		
	500	600	700	800	900	1000	1100	1200	1300	1400	1500	1600	1700	1800	1900	2000	2100	2200	2300
	Pressure Drop (inches water column)																		
20 x 20 x 1	0.05	0.07	0.08	0.10	0.12	0.13	0.14	0.15	—	—	—	—	—	—	—	—	—	—	—
20 x 24 x 1	—	—	—	—	0.09	0.1	0.11	0.13	0.14	0.15	0.16	—	—	—	—	—	—	—	—
24 x 30 x 1	—	—	—	—	—	—	—	0.07	0.08	0.09	0.1	0.11	0.12	0.13	0.14	0.15	0.16	0.17	0.18
24 x 36 x 1	—	—	—	—	—	—	—	0.06	0.07	0.07	0.08	0.09	0.09	0.10	0.11	0.12	0.13	0.14	0.14

Minimum Filter Requirements:

20 x 20 x 1 = PAN424

20 x 24 x 1 = PAN430

24 x 30 x 1 = PAN436, PAN442

24 x 36 x 1 = PAN448, PAN460

MINIMUM AIRFLOW FOR RELIABLE ELECTRIC HEATER OPERATION (CFM)

Model Size:	24	30	36	42	48	60
Airflow:	800	1000	1200	1400	1600	1750

ELECTRIC HEATER USAGE, 208/230-1-60

Electric Heater Model Number	Nominal Capacity (kW)	Fuses	Used With Model Sizes					
			24	30	36	42	48	60
EHNA05K0N	5.0	0	✓	✓	✓	✓	✓	✓
EHNA07K0N	7.5	0	✓	✓	✓	✓	✓	✓
EHNA10K0N	10.0	0	✓	✓	✓	✓		
EHNA10K4F	10.0	4					✓	✓
EHNA15K4F	15.0	4		✓	✓	✓		
EHNA15K6F	15.0	6					✓	✓
EHNA20K6F	20.0	6				✓	✓	✓

ELECTRIC HEATER ELECTRICAL DATA

MODEL SIZE	NOMINAL V-PH-HZ	VOLTAGE RANGE		ELECTRIC HEAT (208V / 230V)		POWER SUPPLY (208V / 230V)	
		MIN	MAX	NOMINAL kW	Full Load Ampacity	Minimum Circuit Ampacity	Maximum Over-Current Protection
24	208/230-1-60	187	253	- / -	- / -	21.0 / 21.0	30 / 30
				3.8 / 5	18.1 / 20.8	27.8 / 31.1	30 / 35
				5.4 / 7.2	25.9 / 30	37.5 / 42.6	40 / 45
				7.5 / 10	36.1 / 41.7	50.3 / 57.3	60 / 60
30	208/230-1-60	187	253	- / -	- / -	21.0 / 21.0	30 / 30
				3.8 / 5	18.1 / 20.8	27.8 / 31.1	30 / 35
				5.4 / 7.2	25.9 / 30	37.5 / 42.6	40 / 45
				7.5 / 10	36.1 / 41.7	50.3 / 57.3	60 / 60
36	208/230-1-60	187	253	- / -	- / -	24.5 / 24.5	35 / 35
				3.8 / 5	18.1 / 20.8	30.1 / 33.5	35 / 35
				5.4 / 7.2	25.9 / 30	39.9 / 45.0	40 / 45
				7.5 / 10	36.1 / 41.7	52.6 / 59.6	60 / 60
42	208/230-1-60	187	253	- / -	- / -	29.3 / 29.3	45 / 45
				3.8 / 5	18.1 / 20.8	30.1 / 33.5	45 / 45
				5.4 / 7.2	25.9 / 30	39.9 / 45.0	45 / 45
				7.5 / 10	36.1 / 41.7	52.6 / 59.6	60 / 60
48	208/230-1-60	187	253	11.3 / 15	54.2 / 62.5	75.3 / 85.6	80 / 90
				15 / 20	72.2 / 83.3	97.8 / 111.6	100 / 125
				- / -	- / -	36.4 / 36.4	50 / 50
				3.8 / 5	18.1 / 20.8	36.4 / 36.4	50 / 50
60	208/230-1-60	187	253	5.4 / 7.2	25.9 / 30	41.9 / 47.0	50 / 50
				7.5 / 10	36.1 / 41.7	54.6 / 61.6	60 / 70
				11.3 / 15	54.2 / 62.5	77.3 / 87.6	80 / 90
				15 / 20	72.2 / 83.3	99.8 / 113.6	100 / 125

ELECTRIC HEATER PRESSURE DROP

Small Cabinet - Model Sizes 24, 30, 36

Heater Size	CFM											
	500	600	700	800	900	1000	1100	1200	1300	1400	1500	1600
	Static Pressure Drop Due to Electric Heater (inches water column)											
5 kW	0.00	0.00	0.00	0.00	0.00	0.00	0.00	0.00	0.02	0.04	0.06	0.07
10 kW	0.00	0.00	0.00	0.00	0.00	0.02	0.04	0.06	0.07	0.09	0.10	0.11
15 kW	0.00	0.00	0.00	0.02	0.04	0.06	0.08	0.10	0.12	0.14	0.16	0.18
20 kW	0.00	0.00	0.02	0.04	0.06	0.08	0.09	0.11	0.13	0.15	0.17	0.19

Large Cabinet - Model Sizes 42, 48, 60

Heater Size	CFM														
	1100	1200	1300	1400	1500	1600	1700	1800	1900	2000	2100	2200	2300	2400	2500
	Static Pressure Drop Due to Electric Heater (inches water column)														
5 kW	0.00	0.00	0.00	0.01	0.02	0.03	0.04	0.05	0.06	0.07	0.08	0.09	0.10	0.11	0.12
10 kW	0.00	0.00	0.01	0.02	0.03	0.04	0.05	0.06	0.07	0.08	0.09	0.10	0.11	0.12	0.13
15 kW	0.00	0.02	0.03	0.04	0.05	0.06	0.07	0.08	0.09	0.10	0.11	0.12	0.13	0.14	0.15
20 kW	0.02	0.03	0.04	0.05	0.06	0.07	0.08	0.09	0.10	0.11	0.12	0.13	0.14	0.15	0.16

PAN424 EXTENDED COOLING PERFORMANCE

EVAPORATOR AIR		CONDENSER ENTERING AIR TEMPERATURES °F (°C)																	
CFM / BF	Ewb	75 (23.9)			85 (29.4)			95 (35)			105 (40.6)			115 (46.1)			125 (51.7)		
		Capacity BTU/h x 1000		Total System kW	Capacity BTU/h x 1000		Total System kW	Capacity BTU/h x 1000		Total System kW	Capacity BTU/h x 1000		Total System kW	Capacity BTU/h x 1000		Total System kW	Capacity BTU/h x 1000		Total System kW
		Total	Sens		Total	Sens		Total	Sens		Total	Sens		Total	Sens		Total	Sens	
700 / 0.02	57	23.13	23.13	1.51	21.91	21.91	1.72	20.50	20.50	1.96	18.92	18.92	2.21	17.16	17.16	2.50	15.20	15.20	2.81
	62	24.10	21.63	1.51	22.43	20.43	1.73	20.57	20.42	1.96	18.92	18.92	2.21	17.15	17.15	2.50	15.20	15.20	2.81
	63*	24.71	17.79	1.51	23.02	16.68	1.73	21.08	15.52	1.96	18.86	14.31	2.21	16.35	13.06	2.49	13.60	13.49	2.78
	67	26.79	18.40	1.51	25.29	17.46	1.73	23.34	16.34	1.98	21.10	15.15	2.24	18.59	13.94	2.52	15.78	12.69	2.82
	72	28.73	14.69	1.52	27.87	14.14	1.74	26.34	13.34	1.98	24.27	12.35	2.26	21.74	11.26	2.56	18.87	10.11	2.88
800 / 0.03	57	24.40	24.40	1.53	23.11	23.11	1.75	21.64	21.64	1.99	19.98	19.98	2.25	18.13	18.13	2.54	16.08	16.08	2.85
	62	24.87	23.37	1.53	23.20	23.00	1.75	21.64	21.64	1.99	19.98	19.98	2.25	18.13	18.13	2.54	16.08	16.08	2.85
	63*	25.40	19.01	1.53	23.70	17.92	1.75	21.68	16.72	1.99	19.39	15.47	2.24	16.83	14.16	2.52	14.31	14.31	2.82
	67	27.34	19.51	1.53	25.95	18.71	1.75	24.00	17.61	2.00	21.67	16.38	2.27	19.09	15.13	2.55	16.24	13.80	2.85
	72	29.18	15.26	1.54	28.30	14.76	1.76	26.88	14.05	2.01	24.85	13.13	2.28	22.30	12.04	2.58	19.34	10.88	2.91
900 / 0.03	57	25.44	25.44	1.55	24.15	24.15	1.77	22.62	22.62	2.02	20.89	20.89	2.29	18.97	18.97	2.57	16.83	16.83	2.89
	62	25.53	25.30	1.55	24.15	24.15	1.77	22.62	22.62	2.02	20.89	20.89	2.29	18.96	18.96	2.57	16.83	16.83	2.89
	63*	25.90	20.12	1.55	24.23	19.09	1.77	22.15	17.86	2.02	19.82	16.57	2.27	17.24	15.18	2.54	14.96	14.96	2.85
	67	27.68	20.49	1.55	26.43	19.86	1.77	24.51	18.81	2.02	22.14	17.58	2.30	19.50	16.26	2.58	16.82	16.82	2.89
	72	29.46	15.74	1.56	28.58	15.29	1.78	27.24	14.69	2.03	25.27	13.83	2.30	22.72	12.78	2.60	19.71	11.61	2.93

PAN430 COOLING PERFORMANCE

EVAPORATOR AIR		CONDENSER ENTERING AIR TEMPERATURES °F (°C)																	
CFM / BF	Ewb	75 (23.9)			85 (29.4)			95 (35)			105 (40.6)			115 (46.1)			125 (51.7)		
		Capacity BTU/h x 1000		Total System kW	Capacity BTU/h x 1000		Total System kW	Capacity BTU/h x 1000		Total System kW	Capacity BTU/h x 1000		Total System kW	Capacity BTU/h x 1000		Total System kW	Capacity BTU/h x 1000		Total System kW
		Total	Sens		Total	Sens		Total	Sens		Total	Sens		Total	Sens		Total	Sens	
875 / 0.03	57	28.46	28.46	1.82	26.75	26.75	2.05	24.89	24.89	2.31	22.87	22.87	2.60	20.70	20.70	2.91	18.40	18.40	3.25
	62	29.16	24.94	1.82	27.05	24.24	2.05	24.89	24.89	2.31	22.86	22.86	2.60	20.70	20.70	2.91	18.39	18.39	3.25
	63*	29.82	20.37	1.82	27.65	19.70	2.06	25.25	18.93	2.31	22.60	18.05	2.59	19.73	17.05	2.89	16.70	15.92	3.21
	67	32.32	21.11	1.81	30.19	20.56	2.06	27.78	19.87	2.33	25.09	19.05	2.63	22.19	18.13	2.93	19.08	17.11	3.26
	72	35.18	16.93	1.82	33.30	16.52	2.06	31.09	15.99	2.33	28.50	15.30	2.63	25.62	14.49	2.97	22.41	13.55	3.33
1000 / 0.04	57	29.83	29.83	1.85	28.06	28.06	2.10	26.12	26.12	2.37	24.01	24.01	2.65	21.74	21.74	2.97	19.33	19.33	3.31
	62	30.00	26.83	1.85	28.06	28.06	2.10	26.11	26.11	2.37	24.00	24.00	2.65	21.74	21.74	2.97	19.33	19.33	3.31
	63*	30.52	21.77	1.85	28.31	21.13	2.10	25.84	20.35	2.36	23.13	19.46	2.64	20.21	18.43	2.94	17.36	17.36	3.26
	67	32.96	22.50	1.85	30.84	22.03	2.09	28.40	21.37	2.37	25.67	20.57	2.67	22.69	19.62	2.99	19.55	18.54	3.31
	72	35.69	17.67	1.85	33.82	17.32	2.10	31.62	16.85	2.37	29.05	16.22	2.67	26.12	15.44	3.01	22.85	14.52	3.37
1125 / 0.05	57	30.95	30.95	1.88	29.15	29.15	2.13	27.15	27.15	2.41	24.97	24.97	2.71	22.62	22.62	3.03	20.12	20.12	3.37
	62	30.94	30.94	1.88	29.15	29.15	2.13	27.15	27.15	2.41	24.96	24.96	2.71	22.62	22.62	3.03	20.12	20.12	3.37
	63*	31.04	23.08	1.88	28.81	22.48	2.13	26.30	21.70	2.40	23.56	20.78	2.68	20.65	20.48	2.99	18.05	18.05	3.32
	67	33.41	23.79	1.88	31.32	23.40	2.13	28.87	22.80	2.40	26.11	22.00	2.71	23.10	21.02	3.04	20.11	20.11	3.37
	72	36.05	18.34	1.89	34.17	18.04	2.13	31.98	17.63	2.41	29.41	17.06	2.71	26.48	16.33	3.05	23.17	15.44	3.41

– refer to Legend, Notes, and Formulas at the end of the chart –

SPECIFICATIONS SUBJECT TO CHANGE WITHOUT NOTICE

PAN436 COOLING PERFORMANCE																			
EVAPORATOR AIR		CONDENSER ENTERING AIR TEMPERATURES °F (°C)																	
CFM / BF	Ewb	75 (23.9)			85 (29.4)			95 (35)			105 (40.6)			115 (46.1)			125 (51.7)		
		Capacity BTU/h x 1000		Total System kW	Capacity BTU/h x 1000		Total System kW	Capacity BTU/h x 1000		Total System kW	Capacity BTU/h x 1000		Total System kW	Capacity BTU/h x 1000		Total System kW	Capacity BTU/h x 1000		Total System kW
		Total	Sens		Total	Sens		Total	Sens		Total	Sens		Total	Sens		Total	Sens	
1050 / 0.02	57	33.74	33.74	2.21	31.86	31.86	2.47	29.86	29.86	2.76	27.71	27.71	3.08	25.42	25.42	3.42	23.00	23.00	3.79
	62	34.63	29.69	2.22	32.34	29.18	2.48	29.93	29.78	2.76	27.71	27.71	3.08	25.42	25.42	3.42	23.00	23.00	3.79
	63*	35.42	24.26	2.23	33.09	23.73	2.49	30.56	23.09	2.77	27.82	22.33	3.08	24.86	21.44	3.40	21.70	20.43	3.75
	67	38.42	25.21	2.23	36.04	24.74	2.50	33.47	24.17	2.80	30.67	23.47	3.13	27.66	22.66	3.47	24.44	21.74	3.83
	72	42.11	20.41	2.24	39.77	19.99	2.51	37.26	19.49	2.81	34.52	18.88	3.14	31.52	18.16	3.50	28.25	17.30	3.89
1200 / 0.03	57	35.34	35.34	2.28	33.39	33.39	2.55	31.30	31.30	2.84	29.06	29.06	3.16	26.68	26.68	3.50	24.14	24.14	3.88
	62	35.58	32.00	2.28	33.39	33.39	2.55	31.30	31.30	2.84	29.06	29.06	3.16	26.67	26.67	3.50	24.14	24.14	3.88
	63*	36.26	25.97	2.28	33.86	25.44	2.55	31.25	24.80	2.83	28.44	24.04	3.14	25.41	23.15	3.47	22.21	22.09	3.82
	67	39.24	26.97	2.28	36.82	26.54	2.55	34.20	26.00	2.85	31.34	25.31	3.18	28.25	24.49	3.54	24.96	23.55	3.90
1350 / 0.03	72	42.80	21.39	2.29	40.39	20.99	2.56	37.86	20.53	2.86	35.10	19.97	3.19	32.08	19.29	3.55	28.76	18.46	3.95
	57	36.70	36.70	2.33	34.69	34.69	2.60	32.53	32.53	2.90	30.20	30.20	3.23	27.73	27.73	3.59	25.09	25.09	3.96
	62	36.70	36.70	2.33	34.69	34.69	2.60	32.52	32.52	2.90	30.20	30.20	3.23	27.72	27.72	3.59	25.09	25.09	3.96
	63*	36.89	27.59	2.33	34.44	27.08	2.60	31.78	26.44	2.90	28.92	25.68	3.21	25.86	24.75	3.54	22.78	22.78	3.90
	67	39.83	28.62	2.33	37.38	28.23	2.60	34.73	27.73	2.90	31.84	27.07	3.23	28.71	26.25	3.60	25.40	25.24	3.97
72	43.27	22.31	2.35	40.81	21.92	2.62	38.24	21.49	2.92	35.47	20.97	3.25	32.45	20.35	3.61	29.11	19.57	4.00	

PAN442 COOLING PERFORMANCE																			
EVAPORATOR AIR		CONDENSER ENTERING AIR TEMPERATURES °F (°C)																	
CFM / BF	Ewb	75 (23.9)			85 (29.4)			95 (35)			105 (40.6)			115 (46.1)			125 (51.7)		
		Capacity BTU/h x 1000		Total System kW	Capacity BTU/h x 1000		Total System kW	Capacity BTU/h x 1000		Total System kW	Capacity BTU/h x 1000		Total System kW	Capacity BTU/h x 1000		Total System kW	Capacity BTU/h x 1000		Total System kW
		Total	Sens		Total	Sens		Total	Sens		Total	Sens		Total	Sens		Total	Sens	
1225 / 0.03	57	39.18	39.18	2.56	36.42	36.42	2.90	33.76	33.76	3.28	31.03	31.03	3.70	28.30	28.30	4.17	25.52	25.52	4.68
	62	40.87	35.89	2.57	37.42	34.32	2.91	34.11	32.73	3.28	31.02	31.02	3.70	28.29	28.29	4.17	25.52	25.52	4.68
	63*	42.42	29.68	2.58	38.64	28.15	2.92	35.18	26.75	3.29	31.48	25.22	3.70	27.69	23.63	4.16	23.81	21.97	4.65
	67	46.44	30.98	2.60	42.97	29.69	2.95	39.60	28.41	3.33	36.16	27.09	3.75	32.63	25.72	4.22	28.89	24.22	4.72
	72	50.49	25.03	2.63	47.40	24.14	2.98	43.83	22.99	3.36	40.24	21.81	3.79	36.59	20.60	4.26	32.85	19.35	4.77
1400 / 0.04	57	41.90	41.90	2.62	38.93	38.93	2.96	36.19	36.19	3.34	33.33	33.33	3.77	30.43	30.43	4.24	27.48	27.48	4.75
	62	42.97	39.09	2.63	39.22	37.25	2.96	36.18	36.18	3.34	33.33	33.33	3.77	30.42	30.42	4.24	27.48	27.48	4.75
	63*	43.96	31.91	2.63	40.21	30.40	2.97	36.67	28.96	3.35	32.87	27.39	3.76	28.97	25.74	4.22	24.93	23.97	4.71
	67	47.54	33.05	2.65	43.97	31.76	2.99	40.50	30.45	3.38	36.96	29.10	3.80	33.35	27.69	4.27	29.66	26.21	4.78
1575 / 0.05	72	51.19	26.03	2.68	48.08	25.20	3.03	44.60	24.15	3.41	40.91	22.95	3.84	37.20	21.73	4.31	33.39	20.47	4.83
	57	44.01	44.01	2.67	41.03	41.03	3.02	38.13	38.13	3.40	35.17	35.17	3.83	32.15	32.15	4.30	29.08	29.08	4.82
	62	44.16	43.83	2.67	41.03	41.03	3.02	38.12	38.12	3.40	35.17	35.17	3.83	32.15	32.15	4.30	29.08	29.08	4.82
	63*	44.80	33.83	2.68	41.29	32.44	3.02	37.88	31.05	3.40	34.03	29.43	3.82	30.01	27.70	4.27	25.94	25.82	4.77
	67	48.33	34.96	2.69	44.73	33.72	3.04	41.17	32.38	3.42	37.57	30.99	3.85	33.89	29.55	4.31	30.16	28.02	4.83
72	51.62	26.90	2.73	48.32	25.98	3.08	45.11	25.19	3.46	41.35	23.97	3.89	37.59	22.76	4.36	33.74	21.50	4.88	

– refer to Legend, Notes, and Formulas at the end of the chart –

6

PAN448 COOLING PERFORMANCE																			
EVAPORATOR AIR		CONDENSER ENTERING AIR TEMPERATURES °F (°C)																	
CFM / BF	Ewb	75 (23.9)			85 (29.4)			95 (35)			105 (40.6)			115 (46.1)			125 (51.7)		
		Capacity BTU/h x 1000		Total System kW	Capacity BTU/h x 1000		Total System kW	Capacity BTU/h x 1000		Total System kW	Capacity BTU/h x 1000		Total System kW	Capacity BTU/h x 1000		Total System kW	Capacity BTU/h x 1000		Total System kW
		Total	Sens		Total	Sens		Total	Sens		Total	Sens		Total	Sens		Total	Sens	
1400 / 0.03	57	48.44	48.44	3.27	45.41	45.41	3.60	42.35	42.35	3.93	39.25	39.25	4.28	36.07	36.07	4.64	34.18	34.18	4.51
	62	50.26	44.05	3.27	46.66	42.03	3.60	43.09	40.02	3.94	39.52	37.98	4.28	36.06	36.06	4.64	34.18	34.18	4.51
	63*	51.28	36.22	3.27	47.58	34.38	3.60	43.89	32.55	3.94	40.18	30.72	4.28	36.42	28.87	4.64	34.30	27.73	4.51
	67	55.09	37.36	3.27	51.09	35.48	3.60	47.11	33.62	3.94	43.10	31.75	4.29	39.02	29.87	4.65	34.78	27.92	5.01
	72	60.45	30.62	3.26	56.04	28.88	3.60	51.64	27.15	3.95	47.22	25.42	4.30	42.71	23.67	4.67	40.74	22.84	4.59
1600 / 0.04	57	50.64	50.64	3.33	47.39	47.39	3.66	44.12	44.12	3.99	40.81	40.81	4.34	38.97	38.97	4.15	33.81	33.81	5.06
	62	51.54	47.47	3.33	47.82	45.31	3.66	44.17	43.97	3.99	40.81	40.81	4.34	38.97	38.97	4.15	33.81	33.81	5.06
	63*	52.46	38.62	3.33	48.59	36.69	3.66	44.75	34.79	4.00	40.90	32.88	4.34	38.86	31.74	4.15	32.95	28.95	5.05
	67	56.33	39.90	3.32	52.15	37.94	3.66	48.00	36.00	4.00	43.84	34.06	4.35	39.61	32.09	4.71	35.22	30.06	5.07
	72	61.77	32.23	3.32	57.17	30.43	3.66	52.59	28.64	4.00	48.00	26.86	4.36	43.32	25.05	4.72	38.45	23.18	5.08
1800 / 0.04	57	52.49	52.49	3.39	49.05	49.05	3.71	45.59	45.59	4.05	42.10	42.10	4.40	40.22	40.22	4.23	34.71	34.71	5.12
	62	52.66	50.62	3.39	49.04	49.04	3.71	45.59	45.59	4.05	42.09	42.09	4.40	38.49	38.49	4.76	36.60	36.60	4.65
	63*	53.37	40.93	3.39	49.37	38.93	3.71	45.40	36.94	4.05	41.44	34.96	4.40	37.42	32.94	4.75	33.28	30.85	5.11
	67	57.27	42.36	3.38	52.95	40.32	3.71	48.67	38.30	4.06	44.39	36.28	4.41	42.36	35.14	4.26	35.55	32.11	5.12
	72	62.77	33.77	3.37	58.02	31.92	3.71	53.29	30.08	4.06	48.56	28.24	4.42	43.75	26.38	4.78	38.76	24.47	5.14

PAN460 COOLING PERFORMANCE																			
EVAPORATOR AIR		CONDENSER ENTERING AIR TEMPERATURES °F (°C)																	
CFM / BF	Ewb	75 (23.9)			85 (29.4)			95 (35)			105 (40.6)			115 (46.1)			125 (51.7)		
		Capacity BTU/h x 1000		Total System kW	Capacity BTU/h x 1000		Total System kW	Capacity BTU/h x 1000		Total System kW	Capacity BTU/h x 1000		Total System kW	Capacity BTU/h x 1000		Total System kW	Capacity BTU/h x 1000		Total System kW
		Total	Sens		Total	Sens		Total	Sens		Total	Sens		Total	Sens		Total	Sens	
1750 / 0.03	57	62.31	62.31	3.82	57.76	57.76	4.31	53.24	53.24	4.85	48.73	48.73	5.45	44.19	44.19	6.12	39.54	39.54	6.85
	62	64.27	54.67	3.84	59.06	52.70	4.32	53.94	50.71	4.86	48.90	48.64	5.45	44.19	44.19	6.12	39.54	39.54	6.85
	63*	65.55	44.79	3.85	60.20	42.97	4.33	54.93	41.12	4.87	49.72	39.25	5.46	44.51	37.32	6.12	39.24	35.29	6.84
	67	70.43	46.23	3.90	64.67	44.38	4.38	59.00	42.51	4.92	53.38	40.61	5.51	47.75	38.65	6.17	42.05	36.58	6.89
	72	77.30	37.72	3.97	70.97	35.99	4.45	64.73	34.24	4.99	58.53	32.45	5.59	52.31	30.59	6.24	45.98	28.62	6.96
2000 / 0.04	57	65.10	65.10	3.93	60.26	60.26	4.42	55.46	55.46	4.96	50.67	50.67	5.57	45.84	45.84	6.24	40.90	40.90	6.97
	62	65.85	59.03	3.94	60.50	56.90	4.42	55.46	55.46	4.96	50.67	50.67	5.57	45.84	45.84	6.24	40.90	40.90	6.97
	63*	66.98	47.84	3.95	61.43	45.94	4.43	55.96	44.02	4.97	50.56	42.07	5.56	45.18	40.06	6.22	39.75	37.95	6.95
	67	71.92	49.46	4.00	65.94	47.53	4.48	60.07	45.59	5.02	54.26	43.62	5.62	48.44	41.58	6.28	42.56	39.43	6.99
	72	78.87	39.76	4.07	72.31	37.97	4.55	65.85	36.16	5.09	59.44	34.32	5.69	53.01	32.41	6.34	46.48	30.38	7.06
2250 / 0.04	57	67.45	67.45	4.04	62.36	62.36	4.53	57.30	57.30	5.07	52.27	52.27	5.68	47.19	47.19	6.35	42.00	42.00	7.08
	62	67.45	67.45	4.04	62.35	62.35	4.53	57.30	57.30	5.07	52.27	52.27	5.68	47.19	47.19	6.35	41.99	41.99	7.08
	63*	68.06	50.78	4.04	62.35	48.81	4.53	56.73	46.83	5.06	51.19	44.81	5.66	45.68	42.72	6.32	40.13	40.51	7.05
	67	73.04	52.59	4.09	66.90	50.60	4.58	60.86	48.59	5.12	54.90	46.55	5.72	48.94	44.43	6.38	42.93	42.19	7.09
	72	80.04	41.72	4.16	73.30	39.89	4.65	66.66	38.03	5.19	60.09	36.14	5.79	53.50	34.18	6.44	46.81	32.11	7.16

* 63°F Ewb is at 75°F entering dry bulb – Tennessee Valley Authority [TVA] rating conditions; all others at 80°F entering dry bulb.

LEGEND: BF — Bypass Factor Ewb — Entering Wet Bulb kW — Total Unit Power Input SHC — Sensible Heat Capacity (x1000 Btu/h) TC — Total Capacity (x1000 Btu/h) (net)

- NOTES:
 1. Ratings are net; they account for the effects of the evaporator fan motor power and heat.
 2. Direct interpolation is permissible. Do not extrapolate.
 3. The following formulas may be used:

$$t_{Ldb} = t_{Edb} - \frac{\text{Sensible Capacity (BTU/h)}}{1.10 \times \text{cfm}} \qquad h_{Lwb} = h_{Ewb} - \frac{\text{Total Capacity (BTU/h)}}{4.5 \times \text{cfm}} \qquad \text{Where: } h_{Ewb} = \text{Enthalpy of air entering evaporator coil}$$

4. The SHC is based on 80°F Edb temperature of air entering evaporator coil.
 Below 80°F Edb, subtract (corr factor x cfm) from SHC.
 Above 80°F Edb, add (corr factor x cfm) to SHC. Correction Factor = 1.10 x (1 + BF) x (Edb + 80).

ACCESSORIES

ROOF CURBS

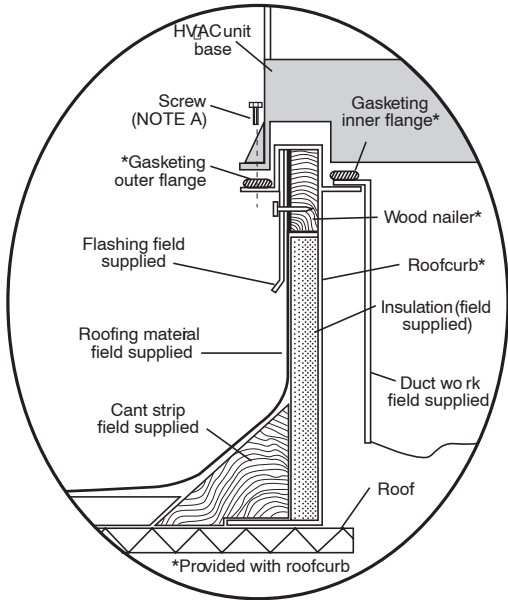

Roof Curb for Small Cabinet

Note A: When unit mounting screw is used, retainer bracket must also be used.

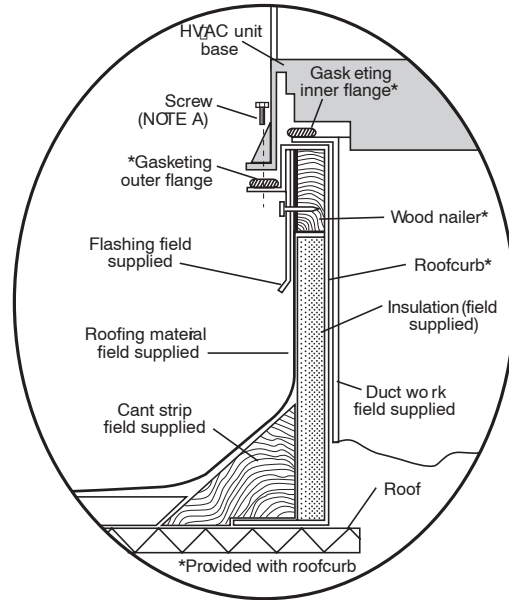

Roof Curb for Large Cabinet

Note A: When unit mounting screw is used, retainer bracket must also be used.

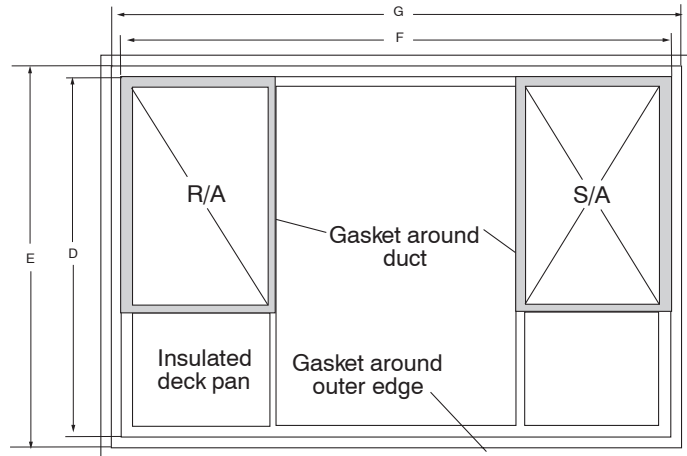
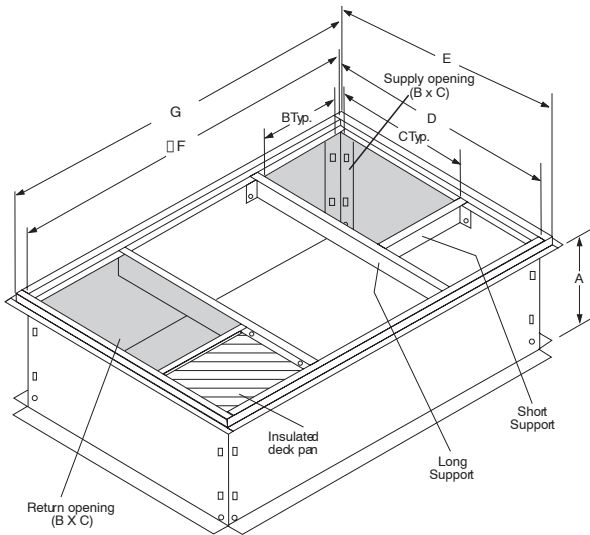

UNIT SIZE	MODEL NUMBER	A IN. [MM]	B IN. [MM]	C IN. [MM]	D IN. [MM]	E IN. [MM]	F IN. [MM]	G IN. [MM]
24, 30, 36	NPRFCURB006A00	8 [203]	11 [279]	16-1/2 [419]	28-3/4 [730]	30-3/8 [771]	44-5/16 [1126]	45-15/16 [1167]
	NPRFCURB007A00	14 [356]	11 [279]	16-1/2 [419]	28-3/4 [730]	30-3/8 [771]	44-5/16 [1126]	45-15/16 [1167]
42, 48, 60	NPRFCURB008A00	8 [203]	16-3/16 [411]	17-3/8 [441]	40-1/4 [1022]	41-15/16 [1065]	44-7/16 [1129]	46-1/16 [1169]
	NPRFCURB009A00	14 [356]	16-3/16 [411]	17-3/8 [441]	40-1/4 [1022]	41-15/16 [1065]	44-7/16 [1129]	46-1/16 [1169]

Notes:

1. Seal strip must be applied as required to unit being installed.
2. Roof curb is made of 16 gauge steel.
3. Attach ductwork to curb (flanges of duct rest on curb).
4. Insulated panels: 1-in. thick fiberglass 1 lb. density.
5. When unit mounting screw is used (see Note A), a retainer bracket must be used as well. This bracket must also be used when required by code for hurricane or seismic conditions. This bracket is available through Micrometl.

ACCESSORIES (continued)

ROOF CURBS

Model Number	Description	Use With Model Size
NPRFCURB006A00	8" High Roof Curb	24, 30, 36
NPRFCURB007A00	14" High Roof Curb	24, 30, 36
NPRFCURB008A00	8" High Roof Curb	42, 48, 60
NPRFCURB009A00	14" High Roof Curb	42, 48, 60

ECONOMIZERS

Model Number	Description	Use With Model Size
NPECOMZR003A00	Vertical or Horizontal, internal with solid state controller, fully modulating damper, up to 50% barometric relief *, supply and dry bulb outdoor air sensors, filter rack with 1-inch filters.**	24, 30, 36
NPECOMZR004A00		42
NPECOMZR006A00		48, 60
AXB078ENT	Outdoor Enthalpy Control	ALL

* Barometric relief only works in the down discharge application

** Outdoor enthalpy available as field installed accessory

MANUAL FRESH AIR DAMPERS

Model Number	Description	Use With Model Size
NPMANDPR004A00	Manual Outside Air Damper – External w/ filter rack and 1" filter	24, 30, 36
NPMANDPR005A00		42
NPMANDPR006A00		48, 60

INTERNAL FILTER RACK and FILTER (shipped with 1" filters)

Model Number	Description	Filter Size	Use With Model Size
NPFILTRK004A00	Horizontal or Downflow Internal Filter Rack	12" x 20" x 1" (quan. 2) or 12" x 20" x 2" (quan. 1) PLUS 10" x 20" x 2" (quan.1)	24, 30, 36
NPFILTRK005A00		12" x 24" x 1" or 2" (3 required)	42
NPFILTRK006A00		12" x 24" x 1" or 2" (3 required)	48, 60

CONCENTRIC DIFFUSER & DUCT TRANSITIONS

Model Number	Description	Use With Model Size
AXB030CSA	STEP DOWN – Fits 2' x 4' Ceiling Grid (Adpats round 18" duct)	ALL
AXB030CFA	FLUSH MOUNT – Fits 2' x 4' Ceiling Grid (Adapts round 18" duct)	ALL
NPDUCLG002A00	Square (14" x 16") to Round (14") – 1 set of 2, use with curb	30, 36, 42, 48

CRANKCASE HEATER (Belly Band Type)

Model Number	Description	Use With Model Size
NPCRKHTR008A00	240V Crankcase Heater	24
NPCRKHTR004A00	240V Crankcase Heater	30, 42, 48

HIGH AND LOW PRESSURE SWITCH KIT, LOW AMBIENT, ANTI-CYCLE TIMER, COMPRESSOR START ASSIST

Model Number	Description	Use With Model Size
AXB035LAA	Low ambient Control – enables cooling system to operate down to 0 Deg. F by cycling condenser fan on and off	ALL
NRTIMEGD001A00	5 minute anti-cycle timer (Note: many thermostats have inherent anti-cycle timer logic)	ALL
NPHSTART001A00	PTC type compressor start assist	ALL

LIFTING / RIGGING KIT

Model Number	Description	Use With Model Size
NPLIFTBK003A10	For Rooftop Applications (Set of 10)	ALL

UNIT DIMENSIONS, model sizes 24, 30, 36

REQUIRED CLEARANCES TO COMBUSTIBLE MATL.

TOP OF UNIT.....	INCHES [MM]
DUCT SIDE OF UNIT.....	14.00 [355.6]
DUCT SIDE OF DUCTS.....	2.00 [50.8]
BOTTOM OF UNIT.....	4.00 [101.6]
FLUE PANEL.....	36.00 [914.4]

NEC REQUIRED CLEARANCES

BETWEEN UNITS, POWER ENTRY SIDE.....	INCHES [MM]
UNIT AND UNGROUNDED SURFACES, POWER ENTRY SIDE.....	12.00 [304.8]
UNIT AND BLOCK OR CONCRETE WALLS AND OTHER GROUNDED SURFACES, POWER ENTRY SIDE.....	36.00 [914.0]

REQUIRED CLEARANCE FOR OPERATION AND SERVICING

EVAP. COIL ACCESS SIDE.....	INCHES [MM]
POWER ENTRY SIDE.....	36.00 [914.4]
(EXCEPT FOR NEC REQUIREMENTS)	42.00 [1066.8]
UNIT TOP.....	48.00 [1219.2]
SIDE OPPOSITE DUCTS.....	36.00 [914.0]
DUCT PANEL.....	12.00 [304.8]

*MINIMUM DISTANCES: IF UNIT IS PLACED LESS THAN 12.00 [304.8] FROM WALL SYSTEM, THEN SYSTEM PERFORMANCE MAYBE COMPROMISED.

DIMENSIONS IN [] ARE IN MILLIMETERS

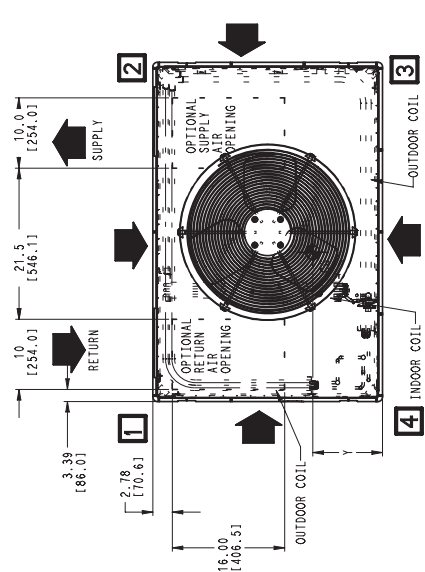

TOP VIEW

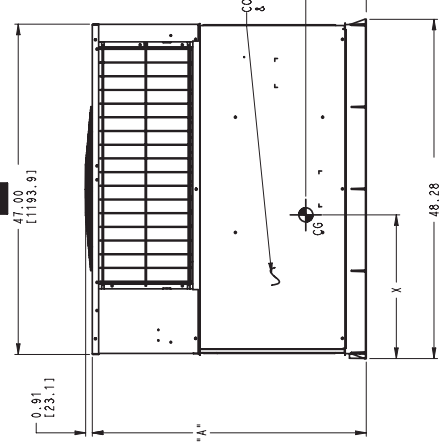

FRONT VIEW

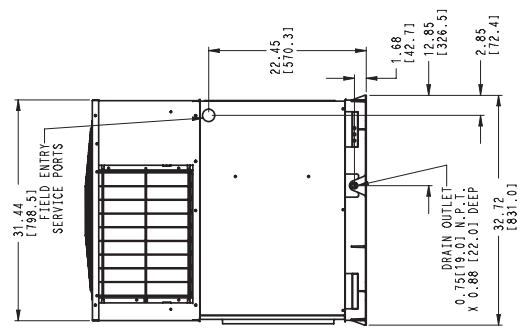

LEFT SIDE VIEW

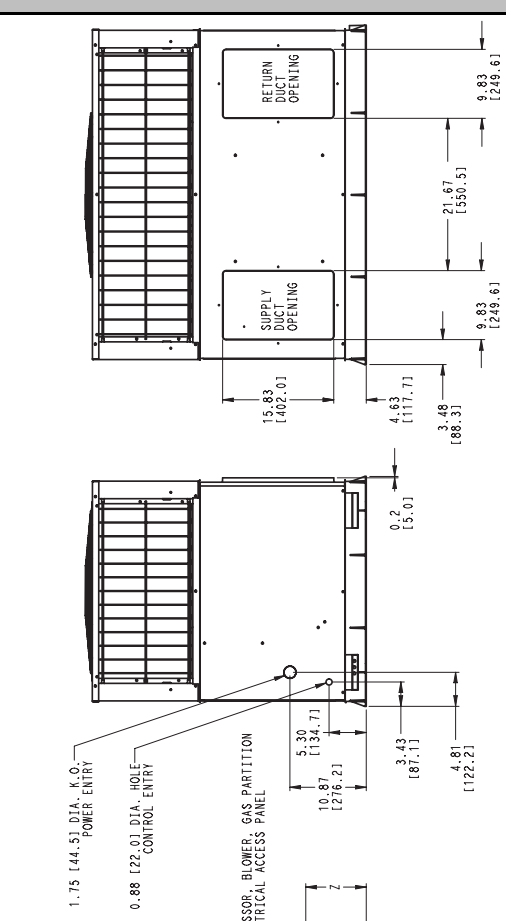

REAR VIEW

RIGHT SIDE VIEW

Model Size	UNIT HEIGHT	CENTER OF GRAVITY			
	inches [mm]	A	X	Y	Z
24	37.02 [940]	37.02 [940]	24.0 [609.6]	16.3 [414.0]	15.7 [398.8]
30	37.02 [940]	37.02 [940]	24.2 [614.7]	16.5 [419.1]	16.0 [406.4]
36	43.02 [1093]	43.02 [1093]	22.8 [579.1]	16.6 [421.6]	16.9 [429.3]

UNIT DIMENSIONS, model sizes 42, 48, 60

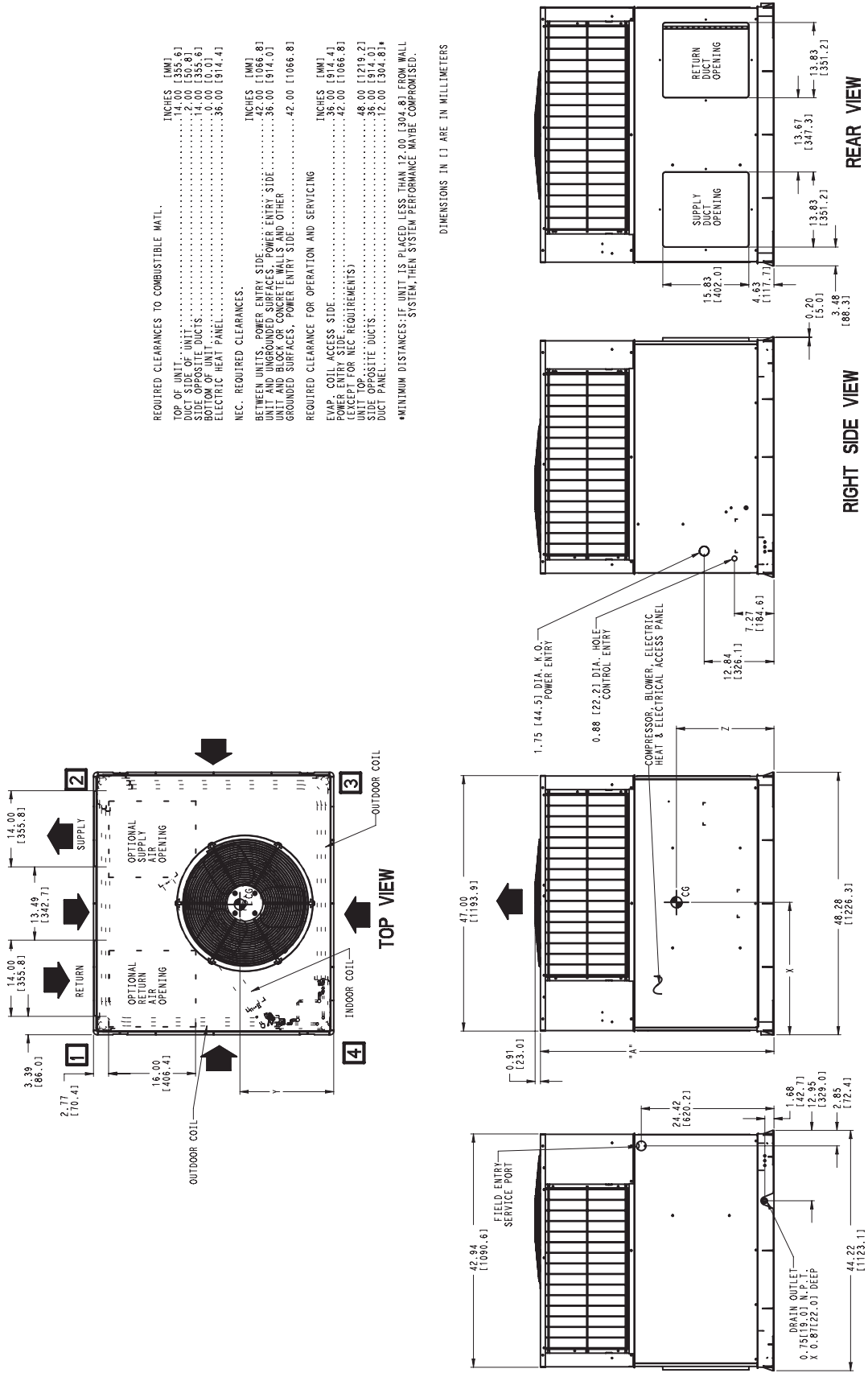

Model Size	UNIT HEIGHT	CENTER OF GRAVITY		
	inches [mm]	A	X	Y
42	46.98 [1193]	24.5 [622.3]	21.3 [541.0]	16.9 [429.3]
48	46.98 [1193]	24.6 [624.8]	22.0 [558.8]	17.5 [444.5]
60	50.98 [1295]	25.5 [647.7]	22.4 [568.9]	19.7 [500.4]

GUIDE SPECIFICATIONS

CABINET

Unit cabinet shall be constructed of phosphated, zinc-coated, pre-painted steel capable of with-standing 500 hours in salt spray. Normal service shall be through a single removable cabinet panel. The unit shall be constructed on a rust proof unit base that has an externally trapped, integrated sloped drain.

Evaporator fan compartment top surface shall be insulated with a minimum 1/2" thick, flexible fiberglass insulation, coated on the air side and retained by adhesive and mechanical means. The evaporator wall sections will be insulated with a minimum semi-rigid foil-faced board capable of being wiped clean. Aluminum foil-faced fiberglass insulation shall be used in the entire indoor air cavity section.

COOLING SECTION

The unit is factory charged and operationally ready upon delivery. The unit refrigerant circuit has a high efficiency scroll compressor with internal overload protection, and copper tube / aluminum fin evaporator and condenser coils. The unit is designed for cooling operation to 40° F and will be capable of being wired for field installed economizer type accessories.

COILS

The evaporator and condenser coils are fabricated with aluminum fins mechanically bonded to copper tubing. Both coils are pressure tested prior to assembly into the unit and electronically leak tested after assembly into the unit.

CONDENSER FAN

The unit has a single direct-drive propeller-fan / motor assembly. The assembly is mounted directly to a vertical-discharge grille that is easily removed for service. Motors are 825 – 1100 RPM with sleeve or ball bearings and internal overload protection.

EVAPORATOR BLOWER

All units have a direct-drive X-13 evaporator blower motor as a standard. The direct-drive evaporator blower motor has sleeve bearings and internal overload protection.

CORNER WEIGHTS and RIGGING DETAILS

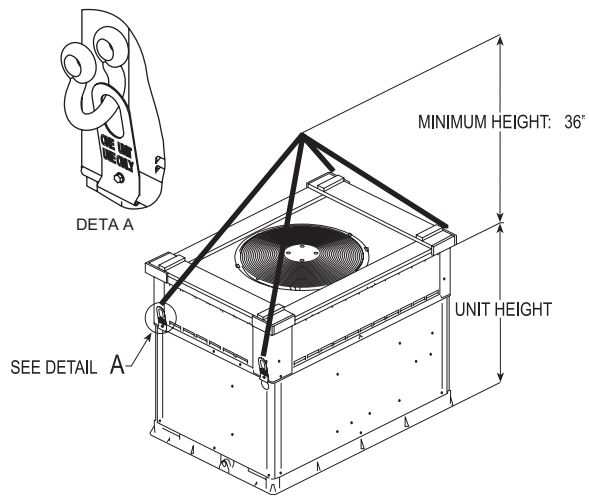
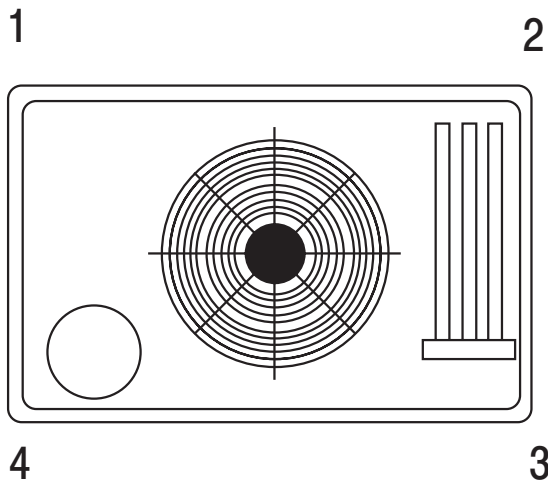

CORNER WEIGHTS (SMALL CABINET)						
Model Size	24		30		36	
	lbs	kg	lbs	kg	lbs	kg
Operating Weight	265	120.2	277	125.6	335	151.9
Corner Weight 1	50	22.7	52	23.6	71	32.2
Corner Weight 2	67	30.4	68	30.8	80	36.3
Corner Weight 3	70	31.8	67	30.4	81	36.7
Corner Weight 4	78	35.4	90	40.8	103	46.7
Rigging Weight	284	128.2	296	134.3	324	160.6
Shipping Weight	319	144.7	331	150.1	389	176.4

CORNER WEIGHTS (LARGE CABINET)						
Model Size	42		48		60	
	lbs	kg	lbs	kg	lbs	kg
Operating Weight	384	174.2	402	182.3	430	195.0
Corner Weight 1	59	26.8	62	28.1	75	34.0
Corner Weight 2	99	44.9	101	45.8	102	46.2
Corner Weight 3	98	44.5	101	45.8	106	48.1
Corner Weight 4	128	58.1	138	62.6	147	66.7
Rigging Weight	406	184.2	424	192.3	452	205
Shipping Weight	446	202.3	464	210.5	492	223.2

MODEL NOMENCLATURE										
MODEL SERIES	P	A	N	4	36	000	K	00	A	1
P = Package										
A = Air Conditioner										
N = R-410A										
4 = 14										
24 = 24,000 BTUH = 2 Tons										
30 = 30,000 BTUH = 2.5 Tons										
36 = 36,000 BTUH = 3 Tons										
42 = 42,000 BTUH = 3.5 Tons										
48 = 48,000 BTUH = 4 Tons										
60 = 60,000 BTUH = 5 Tons										
000 = N/A										
K = 208/230-1-60										
00 = Standard										
Sales Model Digit										
Engineering Digit										