

INDUCER HOUSING KIT

For Single-Stage, Two-Stage and Modulating Gas Furnaces

Installation Instructions

NOTE: Read the entire instruction manual before starting the installation.

SAFETY CONSIDERATIONS

Improper installation, adjustment, alteration, service, maintenance, or use can cause explosion, fire, electrical shock, or other conditions which may cause death, personal injury, or property damage. Consult a qualified installer, service agency, or your distributor or branch for information or assistance. The qualified installer or agency must use factory-authorized kits or accessories when modifying this product. Refer to the individual instructions packaged with the kits or accessories when installing.

Follow all safety codes. Wear safety glasses, protective clothing, and work gloves. Have a fire extinguisher available. Read these instructions thoroughly and follow all warnings or cautions included in literature and attached to the unit. Consult local building codes, the current editions of the National Fuel Gas Code (NFGC) NFPA 54/ANSI Z223.1 and the National Electrical Code (NEC) NFPA 70.

In Canada, refer to the current editions of the National Standards of Canada CAN/CSA-B149.1 and .2 Natural Gas and Propane Installation Codes, and Canadian Electrical Code CSA C22.1.

Recognize safety information. This is the safety-alert symbol . When you see this symbol on the unit and in instructions or manuals, be alert to the potential for personal injury.

Understand the signal words DANGER, WARNING, and CAUTION. These words are used with the safety-alert symbol. DANGER identifies the most serious hazards which will result in severe personal injury or death. WARNING signifies hazards which could result in personal injury or death. CAUTION is used to identify unsafe practices which may result in minor personal injury or product and property damage. NOTE is used to highlight suggestions which will result in enhanced installation, reliability, or operation.

WARNING

FIRE, EXPLOSION, ELECTRICAL SHOCK HAZARD

Failure to follow this warning could result in personal injury, death and/or property damage.

The ability to properly perform maintenance on this equipment requires certain knowledge, mechanical skills, tools, and equipment. If you do not possess these, do not attempt to perform any maintenance on this equipment other than those procedures recommended in the Owner's Manual.

WARNING

FIRE, EXPLOSION, ELECTRICAL SHOCK AND CARBON MONOXIDE POISONING HAZARD

Failure to follow instructions could result in personal injury, death or property damage.

Improper installation, adjustment, alteration, service, maintenance, or use can cause carbon monoxide poisoning, explosion, fire, electrical shock, or other conditions, which could result in personal injury or death. Consult your distributor or branch for information or assistance. The qualified installer or agency must use only factory-authorized kits or accessories when servicing this product.

WARNING

ELECTRICAL SHOCK HAZARD

Failure to follow this warning could result in personal injury or death.

Before installing, modifying, or servicing system, main electrical disconnect switch must be in the OFF position and install a lockout tag. There may be more than one electrical supply to the furnace. Check accessories and cooling unit for additional electrical supplies that must be shut off during furnace servicing. Lockout and tag switch with a suitable warning label. Verify proper operation after servicing.

INTRODUCTION

This instruction covers installation of the single-speed, two-speed, and modulating inducer assemblies on condensing 35-in. (889 mm) tall, high-efficiency units.

The inducer should be replaced when the motor is seized, open, shorted or grounded. The PSC motor is equipped with an internal thermal overload. If the overload is open, allow time (several minutes) for overload to reset.

ECM inducer motors do not have an internal overload and are internally protected through the electronics in the motor controller.

There are four (4) different PSC inducer assemblies to service all single-stage and 2-stage furnaces with PSC inducers.

Each of the four (4) PSC motors have a different horsepower and/or RPM range required for the various size furnaces.

The motor supplied in the kit for furnaces with PSC inducers is a two-speed inducer motor. Single-stage operation is achieved through the use of an adapter harness included with the kit.

There is one (1) kit for modulating furnaces. The replacement assembly may look different from the assembly installed on the furnace, but operates the same as the original motor. The new modulating furnace inducer kit does not require an adapter harness, see [Fig. 1](#).

Refer to [Table 2](#) for the correct furnace and kit combination.

Table 2 – Model Numbers

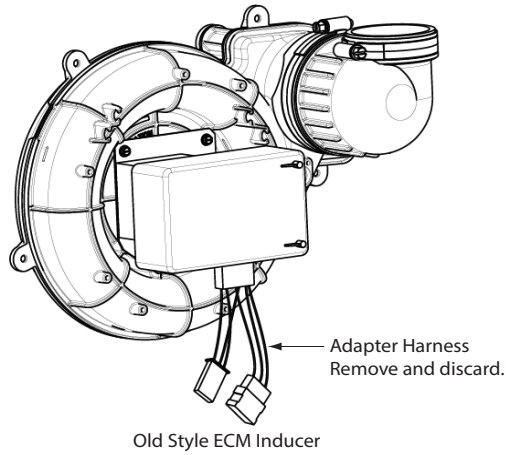

Old Style ECM Inducer

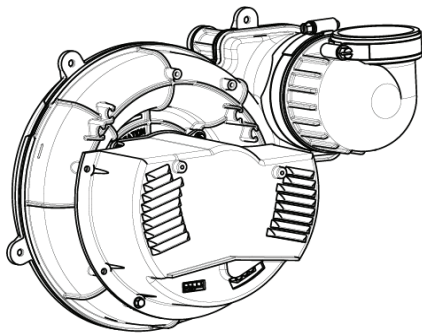

New Style ECM Inducer

Fig. 1 – ECM Inducers

A13034

DESCRIPTION AND USAGE

Use this inducer assembly kit to replace a failed inducer assembly. The assembly cannot be disassembled to remove or repair individual components. The kit contains the following items shown in Table 1.

NOTE: Inducer assembly consists of motor, wheel, inducer housing, inlet gasket, inlet choke plate and condensate drain gasket. It will be necessary to reuse some components from the old inducer assembly.

! CAUTION

UNIT DAMAGE HAZARD

Failure to follow this caution may result in unit damage. Using the incorrect inducer motor assembly could result in no pressure switch operation, poor ignition, poor combustion, erratic burner operation/burner pulsations, flame roll-out or noise.

Table 1 – Kit Contents

Description	Quantity
Inducer Assembly	1
Installation Instructions	1
Inlet Choke Plate (PSC and Ultra Low NOx only)	1 - 2
Inducer Outlet Restrictor (40,000 input only)	1
Two-stage to Single-stage Adapter Harness (PSC only except 140,000 input)	1
1/2-in. # 8 Hex Head Screws 1/2-in.	5
3/8-in. # 8 Hex Head Screws	2

INSTALLATION

SINGLE SPEED PSC INDUCER MODELS	
INPUT	KIT NUMBER*
26,000	1193418
40,000	
60,000	1193419
80,000	
100,000	1193420
120,000	
140,000	1193421
TWO SPEED PSC INDUCER MODELS	
INPUT	KIT NUMBER*
40,000	1193418
60,000	1193419
80,000	
100,000	1193420
120,000	
MODULATING MODELS	
INPUT	KIT NUMBER*
60,000	1193424
80,000	
100,000	
120,000	
ULTRA LOW NOX MODELS	
INPUT	KIT NUMBER*
40,000	1193425
60,000	
80,000	
100,000	
SINGLE SPEED export Models (220 VOLT, 50 Hz ONLY)	
INPUT	KIT NUMBER
100,000	1185902
120,000	
140,000	

*. All brands.

Unit Shut Down

! WARNING

ELECTRICAL SHOCK AND FIRE HAZARD

Failure to follow this warning could result in personal injury, death, and/or property damage.

Turn off the gas and electrical supplies to the furnace and install lockout tag before performing any maintenance or service. Follow the operating instructions on the label attached to the furnace.

1. Set room thermostat to lowest setting or "OFF."
2. Disconnect power at external disconnect, fuse or circuit breaker.
3. Turn off gas at external shut-off or gas meter.
4. Remove outer doors and set aside.
5. Turn gas valve electric switch to "OFF."

Vent Pipe Removal

NOTE: The vent pipe may be connected to the furnace at the rubber vent pipe support. Before cutting the vent pipe, loosen the clamps around the vent pipe coupling and move the vent pipe away from the furnace. Support the vent pipe as close to the furnace as possible to prevent damage to the vent system.

NOTE: If the vent pipe passes through the vent pipe coupling into the vent elbow on the inducer, it may be necessary to cut the vent pipe external to the casing, then re-cement the vent pipe with a field-supplied coupling.

1. Support the vent pipe as close to the furnace as possible to prevent damage to the vent system.
2. Cut vent pipe with a hacksaw and move the remaining vent pipe out of the way. Secure the vent pipe if necessary.
3. Loosen both clamps at the vent pipe support attached to furnace casing.
4. Loosen clamp for the vent pipe at vent elbow on the inducer assembly.
5. Remove remaining vent pipe through the top of the furnace casing and set aside.

! CAUTION

ELECTRICAL OPERATION HAZARD

Failure to follow this caution may result in improper furnace operation or failure of furnace.

Label all wires prior to disconnection when servicing controls. Wiring errors can cause improper and dangerous operation.

! ATTENTION

D'EQUIPEMENT D'OPERATION

Toute erreur de câblage peut être une source de danger et de panne.

Lors des opérations d'entretien des commandes, étiqueter tous les fils avant de les déconnecter.

Pressure Switch or Pressure Transducer Tube Removal

NOTE: There are two types of pressure switches. The modulating pressure switch assembly has three pressure switches. Two are side-by-side with the third switch mounted to the back of one of the switches.

The Ultra Low NOx furnace uses a pressure transducer attached to the inducer wire harness or mounted to a panel instead of a pressure switch. It is not necessary to remove the pressure transducer when replacing the inducer assembly.

All other furnaces have two pressure switches mounted back-to-back. Pressure switches for PSC inducers have a tube on the back pressure switch that connects to the port on the inducer assembly. Pressure switches for the modulating inducers only have one pressure switch tube. The pressure transducer for the Ultra Low NOx model is not connected to the inducer assembly.

1. Remove the front pressure switch or pressure transducer tube from the port on the collector box, see Fig. 2. For Ultra Low NOx models, go to Step 7. all other models, continue with Step 2.
2. Disconnect the pressure switch harness (modulating only) from the main wiring harness or remove the individual wires from the front pressure switch (non-modulating). Note the location of the wires for reassembly.
3. Remove the screws that attach the pressure switch assembly to the inducer.
4. Remove the back pressure switch tube that connects to the inducer assembly (PSC only).
5. Remove the wires from the back pressure switch. Note the location of the wires for reassembly. (PSC only).
6. Set the pressure switches aside.
7. If the relief tube for the condensate trap or pressure transducer tube is routed across the inducer assembly, remove the tube from the port on the collector box and from the stand-offs on the inducer and move the tube aside

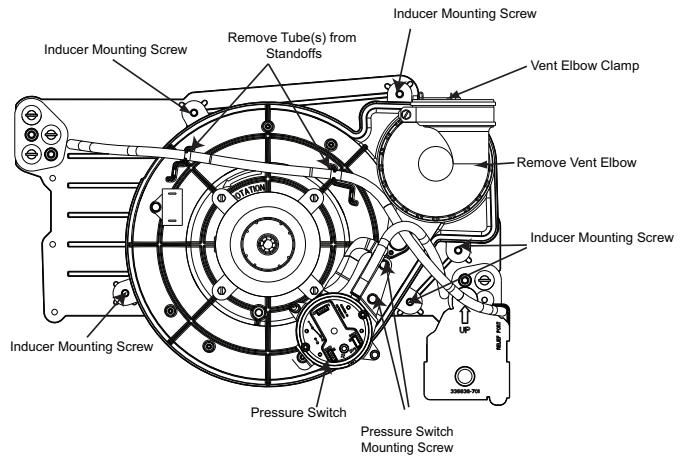

Fig. 2 – Inducer Assembly with Pressure Switches.
(Modulating/Ultra Low NOx model is similar)

A11361

Inducer Assembly Removal

1. Remove the door bracket from the front edge of the blower shelf.
2. Remove the wires that connect the main wiring harness to the inducer motor harness. On furnace using an old style ECM inducer, remove the adapter harness between the inducer motor and main furnace wiring harness and discard, see Fig. 1 and Fig. 3.

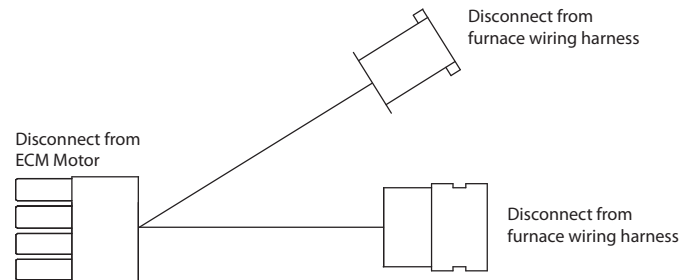

Fig. 3 – ECM Adapter Harness

A12001

3. Remove the screws from the tabs on inducer assembly that secures the inducer to the collector box. Note there is one mounting tab directly under the vent elbow.
4. Remove the inducer assembly and set aside.
5. To avoid double gasketing and leakage, check to make sure the drain gaskets for the inducer and the inducer gasket are not still attached to the collector box.
6. Remove any adhered gaskets from the front of the collector box.
7. Remove the vent elbow from the inducer assembly and set aside.

Inducer Inlet Choke Plate (PSC and Ultra Low NOx inducers only)

NOTE: Some PSC and Ultra Low NOx inducers have a factory-installed Inducer Inlet Choke. The Inlet Choke snaps into the inlet of the Inducer Assembly. A new Choke Plate is included in the loose parts bag of the inducer kit. If a new Choke Plate is required as shown in Table 3 and is not included in the loose parts bag, the choke plate from the old inducer assembly can be re-used in the new assembly. Modulating inducer assemblies do not use an Inlet Choke Plate, see Fig. 4.

1. Un-snap the Inlet Choke from the old inducer assembly.
2. Align the tabs on the Inlet Choke collector box with the slots on the inlet of the replacement inducer assembly and snap into place.

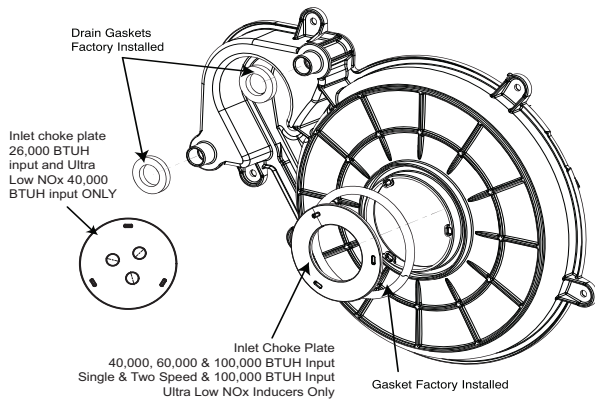

Fig. 4 – Inlet Choke

Table 3 – Inlet Choke Plate Required

Inducer Assembly Installation

SINGLE SPEED PSC INDUCER MODELS		
Input BTUH	Choke Plate Used	Inside diameter
26,000	1188169	(3) 9.7 mm diameter holes
40,000	1185620	44.45 mm
60,000	1185619	31.75 mm
80,000	No	N/A
100,000	1185620	44.45 mm
120,000	No	N/A
140,000	No	N/A
TWO SPEED PSC INDUCER MODELS		
Input BTUH	Choke Plate Required	Inside diameter
40,000	1185620	44.45 mm
60,000	1185619	31.75 mm
80,000	No	N/A
100,000	1185620	44.45 mm
120,000	No	N/A
ULTRA LOW NO _x MODELS		
Input BTUH	Choke Plate Required	Inside diameter
40,000	1188169	(3) 9.7 mm diameter holes
60,000	No	N/A
80,000	No	N/A
100,000	1185620	44.45 mm
MODULATING MODELS - No Choke Plate Required		
SINGLE SPEED EXPORT MODELS (220 VOLT, 50 HZ ONLY)		
Input BTUH	Choke Plate Required	Inside diameter
100,000	1185620	44.45 mm
120,000	No	N/A
140,000	No	N/A

1. Verify any remaining gaskets on the front of the collector box are removed.
2. Verify the inducer assembly has gaskets on the drain stubs and at the inducer inlet.
3. Verify the Inlet Choke Plate (when used) is installed on the inlet opening of the inducer.

! WARNING

CARBON MONOXIDE POISONING HAZARD

Failure to follow this warning could result in personal injury or death. Missing gaskets can increase the risk of increased levels of carbon monoxide.

4. Align the tabs on inducer assembly to the brass inserts on the collector box.
5. Insert the mounting screws by hand through the tabs to secure the inducer to the collector box. Remember there is a mounting tab located under the vent elbow.
6. Tighten the screws in an alternating pattern by hand. Do not use a screw gun or over-tighten the mounting screws.
7. Connect the inducer leads from the main wiring harness to the inducer motor harness.

On Variable Speed furnaces with old style ECM inducers, verify adapter harness has been removed before connecting harness to new ECM motor, see Fig. 3. Otherwise, connect furnace wiring harness directly to motor.

On 2-stage furnaces, connect furnace wiring harness directly to harness on inducer motor.

On single stage furnaces (except 140,000 input), attach adapter harness included in kit to harness on inducer motor. Connect the other end of the adapter harness to the main furnace wiring harness, see Fig. 5. On 140,000 input single-stage furnaces, connect furnace wiring harness directly to harness on inducer motor.

8. Attach the vent elbow to the inducer outlet. Torque the vent elbow clamp 15 lb-in.

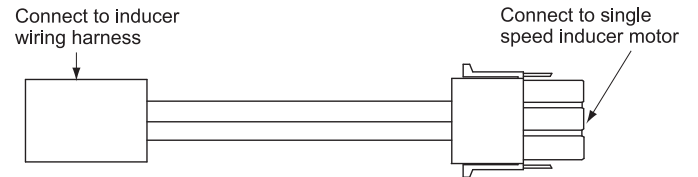

Fig. 5 – Single to Two-Stage PSC Adapter Harness

Pressure Switch or Pressure Transducer Tube Installation

NOTE: There are two types of pressure switches. The modulating pressure switch assembly has three pressure switches. Two are side-by-side with the third switch mounted to the back of one of the switches.

The Ultra Low NO_x furnace uses a pressure transducer mounted to the heat exchanger cell panel instead of a pressure switch. It is not necessary to remove the pressure transducer when replacing the inducer assembly.

All other furnaces have two pressure switches mounted back-to-back.

The tube for the front pressure switch connects the switch to the port on the collector box. The tube for the switch mounted on the back connects the switch to the port on the inducer assembly. The pressure transducer for the Ultra Low NO_x model is not connected to the inducer assembly.

1. Connect the wires to the back pressure switch (PSC only). For Ultra Low NO_x models, go to Step 3. and Step 7. all other models, continue with Step 3.
2. Connect the tube for the back pressure switch to the inducer assembly (PSC only).
3. Connect the tube for the front pressure switch or pressure transducer to the port on the collector box (PSC only).
4. Attach the pressure switch assembly to the inducer.
5. Connect the pressure switch harness (modulating only) to the main wiring harness or attach the individual wires to the pressure switch (non-modulating).
6. If necessary, route the pressure switch tubing for the front pressure switch through the stand-off on the inducer assembly.
7. If necessary, route the condensate trap relief tubing through the stand-off on the inducer assembly. Reconnect tubing to the ports on the condensate trap and collector box.

Inducer Outlet Restrictor (PSC models only)

On 40,000 BTUH input models on vent systems under 10 ft. in length, an inducer outlet restrictor is required at altitudes under 2000-ft (610 M). The outlet restrictor snaps into the outlet of the inducer assembly. If the Outlet restrictor was installed in the old inducer, remove it and re-install it in the replacement inducer.

To install the outlet restrictor:

1. Align the lock tabs on the outlet restrictor with the slots on inside outlet of the inducer assembly.
2. Snap the outlet restrictor in place.
3. Install the vent elbow in the required orientation.
4. Torque vent elbow clamp 15 lb-in.

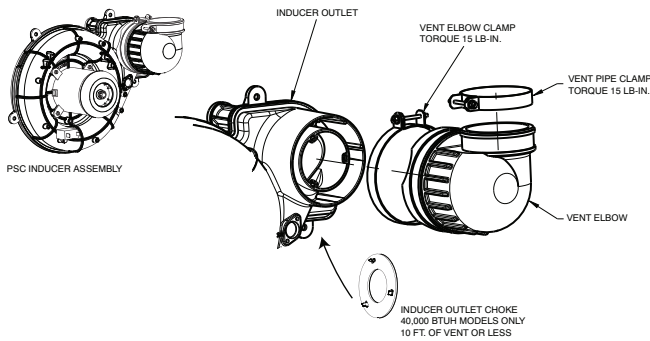

Fig. 6 – Outlet Choke Installation

A150624

Vent Pipe Installation

1. Orient the vent elbow in the required location. Torque the vent elbow clamp 15 lb-in.
2. Insert the vent pipe through the furnace casing and into the outlet of the inducer vent elbow.
3. Tighten the clamp for the vent pipe at vent elbow on the inducer assembly.
4. Align the remaining vent pipe system to the vent pipe in the furnace casing.
5. Solvent cement the pipes as required for the type of material used.
6. Tighten both clamps at the vent pipe support attached to furnace casing.

Unit Checkout

1. Set thermostat to “OFF”.
2. Turn on power at external disconnect, fuse or circuit breaker.
3. Turn on gas at external shut-off or gas meter.

! WARNING

FIRE AND EXPLOSION HAZARD

Failure to follow this warning could result in a fire, explosion, personal injury or death.

NEVER purge a gas line into a combustion chamber. NEVER test for gas leaks with an open flame. Use a commercially available soap solution made specifically for the detection of leaks to check all connections. A fire or explosion may result causing property damage, personal injury, or loss of life.

! AVERTISSEMENT

RISQUE D'EXPLOSION ET D'INCENDIE

Le non-respect des avertissements de sécurité pourrait d'entraîner des blessures graves, la mort ou des dommages matériels.

Ne jamais utiliser une flamme nue pour vérifier la présence des fuites de gaz. Pour la vérification de tous les joints, utiliser plutôt une solution savonneuse commerciale fabriquée spécifiquement pour la détection des fuites de gaz. Un incendie ou une explosion peut entraîner des dommages matériels, des blessures ou la mort.

4. Check for gas leaks with a commercially available soap solution made specifically for the detection of leaks.
5. Manually close blower door switch.
6. Turn gas valve electric switch to “ON.”

! WARNING

ELECTRICAL OPERATION HAZARD

Failure to follow this warning could result in personal injury or death. Blower door switch opens 115-v power to control. No component operation can occur unless switch is closed. Caution must be taken when manually closing this switch for service purposes.

7. Initiate component test through circuit board by referring to “Component Test” on status code label on blower access door for complete test sequence information.
8. If any status codes are flashed, refer to status code label on unit blower door.
9. Turn thermostat fan switch to “ON”, “Continuous” or jumper R to G terminals at furnace control board.
10. Check for air leakage around cell panel.
11. Remove jumper(s) or set thermostat fan to “Auto” or “OFF”
12. Release blower door switch
13. Install blower access door
14. Set thermostat to call for heat.
15. Allow unit to initiate a complete call for heat cycle.
16. Check for air leakage around collector box. A whistling noise may indicate air leak in collector box seal.

NOTE: If there is a severe air leak in the collector box seal, pressure switch may not close or will re-open, resulting in no ignition or erratic burner operation.

NOTE: As part of the system check-out, verify that the following conditions are not affecting the operation of the furnace:

- Short Cycling-Defective thermostat: Incorrect thermostat anticipator setting, dirty filter or over-sized furnace.
- Under firing/low BTU input: Set manifold pressure and verify firing rate as shown on rating plate by clocking the gas meter.
- Over firing/high BTU input: Set manifold pressure and verify firing rate as shown on rating plate by clocking the gas meter.
- Low temperature rise: Set unit for correct temperature rise range as shown on unit rating plate.
- Contaminated combustion air: Remove contaminants or provide ample fresh air for combustion.
- Excessive amounts of outside ventilation air: Return air temperature cannot be below 60 degrees F for extended periods of time.
- Incorrect venting or termination: Recirculation of products of combustion into the combustion air pipe can damage the furnace. Verify proper venting and vent termination per installation instructions. For additional information, and a complete sequence of

furnace operation, refer to furnace Installation, Start-Up and Operating Instructions.

17. After System Check-out is complete, set thermostat below room temperature.
18. Verify that burner shuts down and blower completes selected off delay time.
19. Verify furnace operates properly and set thermostat to desired room temperature.
20. Re-install outer door.