

HIGH EFFICIENCY PACKAGE GAS HEATING/ELECTRIC COOLING, R-410A SINGLE PACKAGE ROOFTOP 15 – 25 TONS

BUILT TO LAST, EASY TO INSTALL AND SERVICE

- One-piece, high efficiency gas heating and electric cooling with a low profile, prewired, tested, and charged at the factory
- Dedicated vertical or horizontal air flow duct configuration models. No field kits required.
- Full perimeter base rail with built-in rigging adapters and fork truck slots
- Pre-painted exterior panels and primer-coated interior panels tested to 500 hours salt spray protection
- Fully insulated cabinet
- Two-stage cooling with independent circuits and control on all models
- Redundant gas valve for two stage gas heating capacity control
- Exclusive IGC solid-state control for on-board diagnostics with LED error code designation, burner control logic and energy saving indoor fan motor delay
- High efficiency, gas heat with induced draft flue exhaust design
- Scroll compressors on all models
- All units have high and low pressure switches
- Two inch disposable fiberglass type return air filters in dedicated rack with tool-less filter access door
- Refrigerant circuits contain a liquid line filter drier to trap dirt and moisture
- Exclusive non-corrosive composite condensate pan in accordance with ASHRAE 62 Standard, sloping design; end drain
- Belt drive evaporator-fan motor and pulley combinations available to meet most applications
- Access panels with easy grip handles provide quick and easy access to the blower and blower motor, control box, and compressors.
- “No-strip” screw system has superior holding power and guides screws into position while preventing the screw from stripping the unit’s metal.
- Newly designed terminal board facilitates simple safety circuit troubleshooting and simplified control box arrangement
- Standard outdoor temperature cooling operation range up to 125°F (52°C) and down to 35°F (2°C)
- TXV metering devices on all models to precisely control refrigerant flow
- Large, laminated control wiring and power wiring drawings are affixed to unit to make troubleshooting easy
- Capable of thru-the-base or thru-the-curb gas line routing
- Single point gas and electrical connections



15 Ton



As an Energy Star® Partner, International Comfort Products has determined that this product meets the ENERGY STAR® guidelines for energy efficiency.



WARRANTY

- 15 Year limited warranty on optional stainless steel heat exchanger.
- 10 Year limited warranty on aluminized stainless steel heat exchanger
- 5 Year compressor limited warranty
- 1 Year parts limited warranty

UNIT PERFORMANCE DATA – Two Stage Cooling

UNIT	Dedicated Airflow	Nominal Tons	COOLING		GAS HEATING		Unit Dimensions H x W x L	Unit Weight lb. [kg]
			Net Cap. (Btuh)	EER	Input Cap. (Btuh) Stage 2	Thermal Efficiency %		
RGH181 [^] AA0AAA	Vertical	15	174,000	12.0	220,000 - 400,000	81.0	49-3/8" x 86-3/8" x 127-7/8"	1892 [860]
RGH183 [^] AA0AAA	Horizontal	15	174,000	11.5	220,000- 400,000	81.0	49-3/8" x 86-3/8" x 127-7/8"	1892 [860]
RGH210 [^] AA0AAA	Vertical	17.5	202,000	12.0	220,000 - 400,000	81.0	49-3/8" x 86-3/8" x 141-1/2"	2102 [956]
RGH213 [^] AA0AAA	Horizontal	17.5	202,000	11.3	220,000 - 400,000	81.0	49-3/8" x 86-3/8" x 141-1/2"	2102 [956]
RGH240 [^] AA0AAA	Vertical	20	232,000	12.0	220,000 - 400,000	81.0	57-3/8" x 86-3/8" x 141-1/2"	2247 [1021]
RGH243 [^] AA0AAA	Horizontal	20	232,000	11.4	220,000 - 400,000	81.0	57-3/8" x 86-3/8" x 141-1/2"	2247 [1021]
RGH300 [^] AA0AAA	Vertical	25	282,000	11.2	220,000 - 400,000	81.0	57-3/8" x 86-3/8" x 157-3/4"	2193 [997]
RGH303 [^] AA0AAA	Horizontal	25	282,000	10.5	220,000 - 400,000	81.0	57-3/8" x 86-3/8" x 157-3/4"	2193 [997]

* Indicates Unit voltage: H = 208/230-3-60, L = 460-3-60, S = 575-3-60

[^] See model nomenclature listing for gas heating options.

NOTE: BASE MODEL NUMBERS LISTED. SEE MODEL NOMENCLATURE LISTING FOR ADDITIONAL OPTIONS

TABLE OF CONTENTS

	PAGE		PAGE
MODEL NUMBER NOMENCLATURE	3	FAN PERFORMANCE PULLEY ADJUSTMENT	39
FACTORY OPTIONS AND/OR ACCESSORIES	4	OUTDOOR AIR INTAKE & EXHAUST PERF	40
AHRI COOLING RATING TABLE	9	ELECTRICAL DATA FOR UNITS PRODUCED ON OR AFTER JULY 30, 2012	41
HEAT RATING TABLES	9	ELECTRICAL INFO	42
SOUND PERFORMANCE TABLE	10	WIRE/FUSE OR HACR BREAKER SIZING DATA	44
PHYSICAL DATA	11	ELECTRICAL DATA FOR UNITS PRODUCED PRIOR TO JULY 30, 2012	46
CURBS & WEIGHTS DIMENSIONS	14	ELECTRICAL INFO	47
OPTIONS AND ACCESSORIES WEIGHT ADDERS ..	23	WIRE/FUSE OR HACR BREAKER SIZING DATA	49
APPLICATION DATA	24	SEQUENCE OF OPERATION	51
COOLING TABLES	26	GUIDE SPECIFICATIONS	54
STATIC PRESSURE ADDERS	34		
FAN PERFORMANCE	35		

15 to 25 TON ROOFTOP UNIT FIOP CODES (Use with Model Nomenclature on next page)			
OPTION	DESCRIPTION	NOMENCLATURE	
		CODE	OPTIONS
2	Non-Fused Disconnect Switch	0A	None
4	Easy Access Hinged Panels	4B	2
5	Unpowered Convenience Outlet	AT	5
9	Supply Air Smoke Detector	BR	9
		7C	2, 5
		7K	2,5,9
		BA	5, 9
		8A	2, 9
		AA	4
		6C	2, 4
		6D	2, 4, 5
		6L	2, 4, 5, 9
		7B	2, 4, 9
		AB	4, 5
		AJ	4, 5, 9
		CH	4, 9

MODEL NOMENCLATURE

MODEL SERIES	R	G	H	1	8	1	H	D	A	B	0	A	A	A
Position Number	1	2	3	4	5	6	7	8	9	10	11	12	13	14
R = Rooftop														
G = Gas/Electric		Type												
H = High Efficiency			Efficiency											
181 = 181,000 = 15 Tons Dedicated Vertical SA/RA (SA = Supply Air, RA = Return Air) 183 = 180,000 = 15 Tons Dedicated Horizontal SA/RA 210 = 210,000 = 17.5 Tons Dedicated Vertical SA/RA 213 = 210,000 = 17.5 Tons Dedicated Horizontal SA/RA 240 = 240,000 = 20 Tons Dedicated Vertical SA/RA 243 = 240,000 = 20 Tons Dedicated Horizontal SA/RA 300 = 300,000 = 25 Tons Dedicated Vertical SA/RA 303 = 300,000 = 25 Tons Dedicated Horizontal SA/RA														
Nominal Cooling Capacity														
H = 208/230-3-60 L = 460-3-60 S = 575-3-60														
Voltage														
D = Low Heat E = Medium Heat F = High Heat S = Low Heat, Stainless Steel Heat Exchanger R = Medium Heat, Stainless Steel Heat Exchanger T = High Heat, Stainless Steel Heat Exchanger														
Heating Capacity														
A = Standard Motor (All sizes) C = Medium Static Motor (15 & 17.5 ton with 1 speed IFM, All sizes with 2 speed IFM) B = High Static Motor (15 ton with 1 speed IFM, All sizes with 2 speed IFM) E = High Static - High Efficiency Motor (17.5 to 25 ton with 1 speed IFM) F = Medium Static - High Efficiency Motor (20 & 25 ton with 1 speed IFM) G = High Static Motor/Drive with Hot Gas Reheat (All sizes with 1 speed IFM)														
Motor Option														
A = None B = Temp Economizer w/Bara-relief E = Temp Economizer w/Bara-relief + CO ₂ sensor H = Enthalpy Economizer w/Bara-relief L = Enthalpy Economizer w/Bara-relief + CO ₂ sensor U = Temp. Ultra Low Leak Economizer w/Bara-relief W = Enthalpy Ultra Low Leak Economizer w/Bara-relief P = 2-Position damper														
Outdoor Air Options / Control														
0A = No Options 4B = Non-Fused Disconnect AT = Non-powered 115v C.O. BR = Supply Air Smoke Detector														
Factory Installed Options														
A = Aluminum Fin /Copper Tubes Cond & Evap Coil B = Precoat Aluminum/Copper Cond Coil C = E-Coated Cond Coil														
Condenser / Evaporator Coil Configuration														
A = Standard Motor T = 2 Speed Indoor Fan VFD Controller (For 2-stage units only)														
Motor Type Option														

Table 1 – FACTORY INSTALLED OPTIONS AND FIELD INSTALLED ACCESSORIES

CATEGORY	ITEM	FACTORY INSTALLED OPTION	FIELD INSTALLED ACCESSORY
Cabinet	Dedicated Vertical Air Flow Duct Configuration	X	
	Dedicated Horizontal Air Flow Duct Configuration	X	
	Hinged Access Panels	X	
Coil Options	Copper/Copper indoor and/or outdoor coils	X	
	Pre-coated outdoor coils	X	
	Premium, E-coated outdoor coils	X	
Condenser Protection	Condenser coil hail guard (louvered design)		X
Humidity Control	Hot Gas Reheat Dehumidification System	X	
Controls	Smoke detector (supply air)	X	
	Time Guard II compressor delay control circuit		X
	Phase Monitor		X
Economizers & Outdoor Air Dampers	Economizer IV	X	X
	Low Leak Economizer X for 2-speed Indoor Fan VFD Controller (For 2-stage units only) Vertical & Horizontal supply/return.	X	X
	Motorized 2 position outdoor-air damper	X	X
	Manual outdoor-air damper (25%)		X
	Barometric relief ¹ (Horizontal economizer)	X	X
	Power exhaust		X
Economizer Sensors & IAQ Devices	Single dry bulb temperature sensors ²	X	X
	Single enthalpy sensors ²	X	X
	Differential enthalpy sensors ²		X
	Duct mounted CO ₂ sensor ²		X
	4-in Filter Track Assembly		X
Gas Heat	Propane conversion kit		X
	Stainless steel heat exchanger	X	
	High altitude conversion kit		X
	Flue Discharge Deflector		X
Indoor Motor & Drive	Multiple motor and drive packages	X	
	2-Speed VFD drive motor system	X	
	VFD Remote keypad kit		X
Low Ambient Control	Winter start kit ³		X
	Motormaster head pressure controller ³		X
Power Options	Convenience outlet (unpowered)	X	
	Non-fused disconnect	X	
Roof Curbs	Roof curb 14-in (356mm)		X
	Roof curb 24-in (610mm)		X

NOTES:

1. Included with economizer.
2. Sensors used to optimize economizer performance.
3. See application data for assistance.
4. Non-fused disconnect switch cannot be used when MOCP electrical rating exceeds 70 amps at 460/575 volt and 150 amps at 208/230 volt.

FACTORY OPTIONS AND/OR ACCESSORIES

→ 2-Speed VFD Drive Motor

The 2-speed VFD drive motor system saves energy and installation time by utilizing a Variable Frequency Drive (VFD) to automatically adjust the indoor fan motor speed in sequence with the units cooling operation. Per ASHRAE 90.1 2016 standard, during the first stage of cooling operation the VFD will adjust the fan motor to provide 2/3rd of the total cfm established for the unit. When a call for the second stage of cooling is required, the VFD will allow the total cfm for the unit established (100%). During the heating mode the VFD will allow total design cfm (100%) operation and during the ventilation mode the VFD will allow operation to 2/3rd of total cfm.

Compared to single speed indoor fan motor systems, 2 speed system can save substantial energy, 25%+, versus single speed indoor fan motor systems.

The VFD used in the system has soft start capabilities to slowly ramp up the speeds, thus eliminating any high inrush air volume during initial start-up. It also has internal over-current protection for the fan motor and a field installed display kit that allows adjustment and in depth diagnostics of the VFD.

This system is available on models with 2-stage cooling operation with electro-mechanical controls. Both space sensor and conventional thermostats/controls can be used to provide accurate control in any application.

The system is very flexible for initial fan performance set up and adjustment. The standard factory shipped VFD is pre-programmed to automatically stage the fan speed between the first and second stage of cooling. The unit fan performance static pressure and cfm can be easily adjusted using the traditional means of pulley adjustments. The other means to adjust the unit static and cfm performance is to utilize the field installed Display Kit and adjust the frequency and voltage in the VFD to performance requirements. In either case, once set up, the VFD will automatically adjust the speed between the cooling stage operations.

Economizer (dry-bulb or enthalpy)

Economizers save money. They bring in fresh, outside air for ventilation; and provide cool, outside air to cool your building. This is the preferred method of low-ambient cooling. When coupled to CO₂ sensors, economizers can provide even more savings by coupling the ventilation air to only that amount required.

Economizers are available, installed and tested by the factory, with either enthalpy or dry-bulb temperature inputs. Additional sensors are available as accessories to optimize the economizers.

Economizers include gravity controlled, barometric relief equalizes building pressure and ambient air pressures. This can be a cost effective solution to prevent building pressurization. If further control of exhaust air is required, a dual centrifugal fan power exhaust system is also available.

CO₂ Sensor

Improves productivity and saves money by working with the economizer to intake only the correct amount of outside air for ventilation. As occupants fill your building, the CO₂ sensor detects their presence through increasing CO₂ levels, and opens the economizer appropriately.

When the occupants leave, the CO₂ levels decrease, and the sensor appropriately closes the economizer. This intelligent control of the ventilation air, called Demand Control Ventilation (DCV) reduces the overall load on the rooftop, saving money.

Smoke Detector

Smoke detectors make your application safer and your job easier. Smoke detectors immediately shut down the rooftop unit when smoke is detected. It is available for supply air.

Louvered Hail Guards (accessory only)

Sleek, louvered panels protect the condenser coil from hail damage, foreign objects, and incidental contact.

Convenience Outlet (un-powered)

Reduce service and/or installation costs by including a convenience outlet in your specification. The convenience outlet provides, 15 amp, 115v GFCI receptacle with "Wet in Use" cover. This option is to be powered from a separate 115/120v power source.

Non-Fused Disconnect

This OSHA-compliant, factory-installed, safety switch allows a service technician to locally secure power to the rooftop capable of providing protection to a MOCP maximum of 200A.

Power Exhaust with Barometric Relief

Superior internal building pressure control. This field-installed accessory may eliminate the need for costly, external pressure control fans.

Time Guard II Control Circuit

This accessory protects your compressor by preventing short-cycling in the event of some other failure, prevents the compressor from restarting for 30 seconds after stopping.

Filter or Fan Status Switches (accessory only)

Use these differential pressure switches to detect a filter clog or indoor fan motor failure. When used in conjunction with a compatible unit controller/thermostat, the switches will activate an alarm to warn the appropriate personnel.

Motorized 2-Position Damper

The new 2-position, motorized outdoor air damper admits up to 100% outside air. Using reliable, gear-driven technology, the 2-position damper opens to allow ventilation air and closes when the rooftop stops, stopping unwanted infiltration.

Manual OA Damper (accessory only)

Manual outdoor air dampers are an economical way to bring in ventilation air. The dampers are available in 25% versions.

Motormaster Head Pressure Controller

The Motormaster motor controller is a low ambient, head pressure controller kit that is designed to maintain the unit's condenser head pressure during periods of low ambient cooling operation. This device should be used as an alternative to economizer free cooling not when economizer usage is either not appropriate or desired. The Motormaster will either cycle the outdoor-fan motors or operate them at reduced speed to maintain the unit operation, depending on the model.

FACTORY OPTIONS AND/OR ACCESSORIES (CONT.)

Hot Gas Reheat Adaptive Dehumidification System

Our Hot Gas Reheat adaptive dehumidification system is an all-inclusive factory installed option that can be ordered with any High Static motor.

This system expands the envelope of operation of our rooftop products to provide unprecedented flexibility to meet year round comfort conditions.

The Hot Gas Reheat adaptive dehumidification system has the industry's only dual dehumidification mode setting. The system includes two new modes of operation.

The rooftop unit coupled with the Hot Gas Reheat system is capable of operating in normal design cooling mode, subcooling mode, and hot gas reheat mode. Normal design cooling mode is when the unit will operate under its normal sequence of operation by cycling compressors to maintain comfort conditions.

Subcooling mode will operate to satisfy part load type conditions when the space requires combined sensible and a higher proportion of latent load control. Hot Gas Reheat mode will operate when outdoor temperatures diminish and the need for latent capacity is required for sole humidity control. Hot Gas Reheat mode will provide neutral air for maximum dehumidification operation.

Winter Start Kit (accessory only)

The winter start kit extends the low ambient limit of your rooftop to 25°F (-4°C). The kit bypasses the low pressure switch, preventing nuisance tripping of the low pressure switch. Other low ambient precautions may still be prudent.

Propane Heating (accessory only)

Convert your gas heat rooftop from standard natural gas operation to propane using this field-installed kit.

High Altitude Heating (accessory only)

High altitudes have less oxygen, which means heat exchangers need less fuel. The new gas orifices in this field-installed kit make the necessary adjustment for high altitude applications. They restore the optimal fuel to air mixture and maintain healthy combustion at altitudes above 2000 ft (610m). Kits may not be required in all areas.

Optional Stainless Steel Heat Exchanger

The stainless steel heat exchanger option provides the tubular heat exchanger be made out of a minimum 20 gauge type 409 stainless steel for applications where the mixed air to the heat exchanger is expected to drop below 45°F (7°C). Stainless steel may be specified on applications where the presence of airborne contaminants require its use or in area with very high outdoor humidity that may result in severe condensation in the heat exchanger during cooling operation.

Flue Discharge Deflector (accessory only)

The flue discharge deflector is a useful accessory when flue gas recirculation is a concern. By venting the flue discharge upwards, the deflector minimizes the chance for a neighboring unit to intake the flue exhaust.

Alternate Motors and Drives

Some applications need larger horsepower motors, some need more airflow, and some need both. A wide selection of motors and pulleys (drives) are available, factory installed, to handle nearly any application.

Barometric Hood (accessory only)

For Horizontal Economizer applications where relief damper is installed in duct work. This kit provides the needed protection.

Hinged Access Panels

Allows access to unit's major components with specifically designed hinged access panels. Panels are filter, control box, indoor fan motor.

ACCESSORIES – RGH181–303

FLAT ROOF CURBS		
Model Number	Description	Use With Model Size
CRRFCURB045A00	14" (356 mm) High Roof Curb. Ductwork attaches to the roof curb. Includes thru-the-bottom capability.	181/183
CRRFCURB047A00		210/213 – 240/243
CRRFCURB049A00		300/303
CRRFCURB046A00	24" (607 mm) High Roof Curb. Ductwork attaches to the roof curb. Includes thru-the-bottom capability.	181/183
CRRFCURB048A00		210/213 – 240/243
CRRFCURB050A00		300/303

ECONOMIZERS*1, 2		
Model Number	Description	Use With Model Size
DNECOMZR052A00	Economizer IV, Vertical & Horizontal with solid state controller	181/183 – 210/213
DNECOMZR053A00	Economizer IV, Vertical & Horizontal with solid state controller	240/243 – 300/303
CRECOMZR074A00	Ultra Low Leak Horizontal & Vertical Economizer X with solid-state controller, gear-driven, fully modulating damper, spring return actuator, up to 100% barometric relief, supply and outdoor air sensors, and CO2 sensor compatible.	181/183 – 210/213
CRECOMZR075A00	Ultra Low Leak Horizontal & Vertical Economizer X with solid-state controller, gear-driven, fully modulating damper, spring return actuator, up to 100% barometric relief, supply and outdoor air sensors, and CO2 sensor compatible.	240/243 – 300/303

* Barometric relief hood is not included in the horizontal economizer and must be installed in return ductwork on Horizontal configured models. Order separately, see below, CRBARHOD001A00.

¹ Economizer X cannot be installed with Economizer IV, manual damper, or motorized damper.

² Can only be used on electrical mechanical units with 2-stage cooling and 2-speed fan control.

ECONOMIZER SENSORS		
Model Number	Description	Use With Model Size
DNTEMPSN002A00	Single (dry bulb) Control	Economizers IV
DNCBDIOX005A00	CO2 Sensor and aspirator box for use in return air stream.	Economizers IV & X
DNENTDIF004A00	Return Air Enthalpy Sensor	Economizers IV
AXB078ENT	Enthalpy Control	Economizers IV
CRTEMPSN005A00	Outdoor or return dry bulb temperature sensor used with Honeywell W7220 electro-mechanical control.	Economizer X
HH57AC081	Enthalpy control for W7220 controller only. (One required for single enthalpy, two required for differential enthalpy)	Economizer X

NOTE: Supply air temperature sensor (SAT and low ambient lockout switch) provided with economizer IV or economizer X.

BAROMETRIC RELIEF HOOD		
Model Number	Description	Use With Model Size
CRBARHOD001A00	For horizontal economizer applications where relief damper is installed in duct work, this kit provides needed protection	183 – 213 – 243 – 303

POWER EXHAUST*		
Model Number	Description	Use With Model Size
CRPWREXH068A00	Vertical and Horizontal, 208/230–3–60	181/183–210/213–240/243–300/303
CRPWREXH069A00	Vertical and Horizontal, 460–3–60	181/183–210/213–240/243–300/303
CRPWREXH070A00	Vertical and Horizontal, 575–3–60	181/183–210/213–240/243–300/303

MANUAL OUTDOOR AIR DAMPERS		
Model Number	Description	Use With Model Size
CRMANDPR009A00	25% Open Manual Fresh Air Damper	181/183 – 210/213
CRMANDPR010A00	25% Open Manual Fresh Air Damper	240/243 – 300/303

MOTORIZED OUTDOOR AIR DAMPERS		
Model Number	Description	Use With Model Size
CRTWOPOS012A00	Motorized 2 position outdoor air damper	181/183 – 210/213
CRTWOPOS013A00	Motorized 2 position outdoor air damper	240/243 – 300/303

ACCESSORIES – RGH181–303 (cont.)

LOW AMBIENT CONTROLS		
Model Number	Description	Use With Model Size
CRLOWAMB041A00 ¹	Motormaster I –20° Low Ambient Control 208/230–3–60	181/183–210/213–240/243–300/303
CRLOWAMB042A00 ¹	Motormaster I –20° Low Ambient Control 460–3–60, 575–3–60	181/183–210/213–240/243–300/303
CRTRXKIT001A00	Motormaster I –20° Transformer 575–3–60. Must be used in conjunction with Low Ambient Controller if used on 575–3–60 models.	181/183–210/213–240/243–300/303
¹ Also requires one DNWINSTR001A00 winter start kit per circuit.		
CONTROL UPGRADE KITS		
Model Number	Description	Use With Model Size
CRDISKIT001A00	VFD Remote keypad kit for programming replacement VFD drive module.	ALL
NRTIMEGD001A00	Time Guard II	181 – 303
CRSDTEST001A00	Smoke detector remote Test/Reset/Alarm indicator kit	181 – 303
CRPHASE3001A02	Electronic Phase Monitor – All 208/230/460–3–60 models	181 – 303
CRPHASE3002A00	Electronic Phase Monitor – All 575–3–60 models	181 – 303
CRSTATUS005A00	Fan/filter Status Switch – Indicator light not included	181 – 303
CRSMKSEN002A00	Smoke Detector Control Module	181 – 303
CRSMKKIT002A00	Smoke Detector Control Module (Smoke Detector Sensor with sampling tube & exhaust tube)	181 – 303
DNWINSTR001A00	Winter Start Kit – Contains time delay relay for timed bypass of low pressure switch on startup	181 – 303
PROPANE GAS CONVERSION KITS		
Model Number	Description	Use With Model Size
CRLPKIT9001A00	Propane Conversion kit. for use between 0' to 2,000'	181 – 303
CRLPELEV005A00	Propane and Hi Altitude conversion kit. for use between 2001' to 10,000'	181 – 303
CRLPELEV006A00	Propane and Hi Altitude conversion kit. for use between 10,001' to 14,000'	181 – 303
NATURAL GAS HIGH ALTITUDE CONVERSION KITS		
Model Number	Description	Use With Model Size
CRNGELEV001A00	High Altitude Conversion kit. for use between 3,000' to 10,000'	181 – 303
CRNGELEV002A00	High Altitude Conversion kit. for use between 10,001' to 14,000'	181 – 303
HEATING UPGRADE KITS		
Model Number	Description	Use With Model Size
CRFLUEDS006A00	Flue Discharge Deflector	181 – 303
4" FILTER TRACK UPGRADE KIT		
Model Number	Description	Use With Model Size
CRFLTTRK001A00	4" Field Conversion Kit	181 – 303
LOUVERED HAIL GUARDS		
Model Number	Description	Use With Model Size
CRLVHLGD017A00	Louvered Condenser Coil Hail Guard	181/183
CRLVHLGD030A00	Louvered Condenser Coil Hail Guard	210/213
CRLVHLGD031A00	Louvered Condenser Coil Hail Guard	240/243
CRLVHLGD029A00	Louvered Condenser Coil Hail Guard	300/303

**Table 2 – AHRI COOLING RATING TABLE
VERTICAL CONFIGURATION**

MODEL RGH	COOLING STAGES	NOMINAL CAPACITY (TONS)	NET COOLING CAPACITY (MBH)	TOTAL POWER (kW)	EER	IEER – 1 SPEED INDOOR FAN	IEER – 2 SPEED INDOOR FAN
181	2	15	174.0	14.5	12.0	13.0	13.5
210	2	17.5	202.0	16.8	12.0	13.0	13.6
240	2	20	232.0	19.7	12.0	13.2	13.8
300	2	25	282.0	25.2	11.2	12.0	12.5

HORIZONTAL CONFIGURATION

MODEL RGH	COOLING STAGES	NOMINAL CAPACITY (TONS)	NET COOLING CAPACITY (MBH)	TOTAL POWER (kW)	EER	IEER – 1 SPEED INDOOR FAN	IEER – 2 SPEED INDOOR FAN
183	2	15	174.0	14.5	11.5	12.0	13.0
213	2	17.5	202.0	16.8	11.3	11.5	13.2
243	2	20	232.0	19.7	11.4	12.0	13.0
303	2	25	282.0	25.2	10.5	N/A	11.9

LEGEND

- AHRI – Air-Conditioning, Heating and Refrigeration Institute
- ASHRAE – American Society of Heating, Refrigerating and Air Conditioning Engineers
- IEER – Integrated Energy Efficiency Ratio
- IPLV – Integrated Part Load Value

NOTES:

1. Rated and certified under AHRI Standard 340/360.
2. Ratings are based on:
Cooling Standard: 80°F (27°C) db, 67°F (19°C) wb indoor air temp and 95°F (35°C) db outdoor air temp.
IEER Standard: A measure that expresses cooling part-load EER efficiency for commercial unitary air conditioning and heat pump equipment on the basis of weighted operation at various load capacities.
3. All RGH units meet or exceed ASHRAE 90.1-2016 and IECC-2015 minimum efficiency requirements.
4. RGH units comply with US Energy Policy Act (2005). To evaluate code compliance requirements, refer to state and local codes or visit the following website: <http://bcap-energy.org> to determine if compliance with this standard pertains to your state, territory, or municipality.



As an Energy Star® Partner, International Comfort Products has determined that this product meets the ENERGY STAR® guidelines for energy efficiency.



Table 3 – HEATING RATING TABLE – NATURAL GAS & PROPANE

MODEL RGH	HEAT SIZE	AL/SS HEAT EXCHANGER		TEMP RISE (DEG F)	THERMAL EFFICIENCY (%)
		INPUT / OUTPUT STAGE 1 (MBH)	INPUT / OUTPUT STAGE 2 (MBH)		
181 – 183	LOW	176 / 142	220 / 178	20 – 55	81%
	MED	248 / 200	310 / 251	30 – 60	81%
	HIGH	320 / 260	400 / 324	35 – 65	81%
210 – 213	LOW	176 / 142	220 / 178	15 – 55	81%
	MED	248 / 200	310 / 251	25 – 60	81%
	HIGH	320 / 260	400 / 324	30 – 65	81%
240 – 243	LOW	176 / 142	220 / 178	15 – 55	81%
	MED	248 / 200	310 / 251	20 – 60	81%
	HIGH	320 / 260	400 / 324	30 – 65	81%
300 – 303	LOW	176 / 142	220 / 178	10 – 55	81%
	MED	248 / 200	310 / 251	15 – 60	81%
	HIGH	320 / 260	400 / 324	20 – 65	81%

NOTE:

Heat ratings are for natural gas heat exchangers operated at or below 2000 ft. For information on Propane or altitudes above 2000 ft (610m), see the Application Data section of this book. Accessory Propane/High Altitude kits are also available.

In the USA the input rating for altitudes above 2000 ft (610m) must be derated by 4% for each 1000 ft (305 m) above sea level. In Canada, the input rating must be derated by 10% for altitudes of 2000 ft (610 m) to 4500 ft (1372 m) above sea level.

Table 4 – SOUND PERFORMANCE TABLE

MODEL RGH	COOLING STAGES	Outdoor Sound (dB)									
		A-Wtg.	ARI 370 Rating	63	125	250	500	1000	2000	4000	8000
181 – 183	2	84.1	84	92.2	83.9	80.4	81.8	78.7	76.5	72.2	65.4
210 – 213	2	84.1	84	92.2	83.9	80.4	81.8	78.7	76.5	72.2	65.4
240 – 243	2	86.5	87	95.6	87.5	84.2	84.2	81.7	77.9	73.2	66.3
300 – 303	2	85.9	86	97.1	88.3	84.4	83.3	80.7	77.4	73.4	67.3

LEGEND

dB – Decibel



NOTES:

1. Outdoor sound data is measured in accordance with AHRI standard 270–2008.
2. Measurements are expressed in terms of sound power. Do not compare these values to sound pressure values because sound pressure depends on specific environmental factors which normally do not match individual applications. Sound power values are independent of the environment and therefore more accurate.
3. A-weighted sound ratings filter out very high and very low frequencies, to better approximate the response of “average” human ear. A-weighted measurements are taken in accordance with AHRI standard 270–2008.

Table 5 – MINIMUM – MAXIMUM AIRFLOW RATINGS – NATURAL GAS & LIQUID PROPANE

MODEL RGH	HEAT SIZE	COOLING				AL HEAT EXCHANGER HEATING		SS HEAT EXCHANGER HEATING	
		Minimum Single Speed Fan Motor	Minimum 2–speed Fan Motor (at high speed)	Minimum 2–speed Fan Motor (at low speed)	Maximum	Minimum	Maximum	Minimum	Maximum
181 – 183	LOW					3000	8250	3000	8250
	MED	4500	5070	3346	7500	3880	7750	3880	7750
	HIGH					4620	8570	4620	8570
210 – 213	LOW					3000	11000	2960	11000
	MED	5250	5915	3904	9000	3880	9300	3880	9300
	HIGH					4620	10000	4620	10000
240 – 243	LOW					3000	11000	3000	11000
	MED	6000	7500	4950	10000	3880	11630	3880	11630
	HIGH					4620	10000	4620	10000
300 – 303	LOW					3000	16500	2960	16500
	MED	7500	8450	5577	12500	3880	15500	3880	15500
	HIGH					4620	15000	4620	15000

Table 6 – PHYSICAL DATA (COOLING) 15 – 25 TONS

RGH	181 – 183	210 – 213	240 – 243	300 – 303
Refrigeration System # Circuits / # Comp. / Type R-410a charge A/B (lbs) Metering device High-press. Trip / Reset (psig) Low-press. Trip / Reset (psig) Compressor Capacity Staging (%)	2 / 2 / Scroll 17/16.4 TXV 630 / 505 54 / 117 50% / 100%	2 / 2 / Scroll 17.5/16.8 TXV 630 / 505 54 / 117 50% / 100%	2 / 2 / Scroll 23.8/23.1 TXV 630 / 505 54 / 117 50% / 100%	2 / 2 / Scroll 24.9/27.7 TXV 630 / 505 54 / 117 50% / 100%
Evap. Coil Material Tube Diameter Rows / FPI Total face area (ft2) Condensate drain conn. size	Cu / Al 3/8" RTPF 4 / 15 22 3/4"	Cu / Al 3/8" RTPF 4 / 15 22 3/4"	Cu / Al 3/8" RTPF 4 / 15 26 3/4"	Cu / Al 3/8" RTPF 4 / 15 26 3/4"
Hot Gas Reheat Coil Material Tube Diameter Rows / FPI Total face area (ft2)	Cu / Al 3/8" RTPF 1 / 17 22	Cu / Al 3/8" RTPF 1 / 17 22	Cu / Al 3/8" RTPF 1 / 17 26	Cu / Al 3/8" RTPF 1 / 17 26
Evap. fan and motor VERTICAL				
<div style="border: 1px solid black; padding: 2px; width: fit-content;">Standard Static</div> Motor Qty / Drive type Max BHP RPM range Motor frame size Fan Qty / Type Fan Diameter (in)	1 / Belt 2.2 514–680 56 2 / Centrifugal 15 x 15	1 / Belt 3.3 622–822 56 2 / Centrifugal 15 x 15	1 / Belt 4.9 690–863 56 2 / Centrifugal 15 x 15	1 / Belt 4.9 717–911 56 2 / Centrifugal 15 x 15
<div style="border: 1px solid black; padding: 2px; width: fit-content;">Medium Static</div> Motor Qty / Drive type Max BHP RPM range Motor frame size Fan Qty / Type Fan Diameter (in)	1 / Belt 3.3 679–863 56 2 / Centrifugal 15 x 15	1 / Belt 4.9 713–879 56 2 / Centrifugal 15 x 15	1 / Belt 6.5 835–1021 184T 2 / Centrifugal 15 x 15	1 / Belt 6.5 913–1116 184T 2 / Centrifugal 15 x 15
<div style="border: 1px solid black; padding: 2px; width: fit-content;">High Static</div> Motor Qty / Drive type Max BHP RPM range Motor frame size Fan Qty / Type Fan Diameter (in)	1 / Belt 4.9 826–1009 56 2 / Centrifugal 15 x 15	1 / Belt 6.5 882–1078 184T 2 / Centrifugal 15 x 15	1 / Belt 8.7 941–1176 213T 2 / Centrifugal 15 x 15	1 / Belt 8.7 941–1176 213T 2 / Centrifugal 15 x 15

TABLE 6 – PHYSICAL DATA (COOLING) 15 – 25 TONS (CONT.)



RGH		181 – 183	210 – 213	240 – 243	300 – 303
HORIZONTAL					
Standard Static	Motor Qty / Drive type	1 / Belt	1 / Belt	1 / Belt	1 / Belt
	Max BHP	2.2	3.3	4.9	4.9
	RPM range	514–680	622–822	690–863	647–791
	Motor frame size	56	56	56	184T
	Fan Qty / Type	2 / Centrifugal	2 / Centrifugal	2 / Centrifugal	2 / Centrifugal
	Fan Diameter (in)	18 x 15/15 X 11	18 x 15/15 X 11	18 x 15/15 X 11	18 x 15/15 X 11
Medium Static	Motor Qty / Drive type	1 / Belt	1 / Belt	1 / Belt	1 / Belt
	Max BHP	3.3	4.9	6.5	6.5
	RPM range	614–780	713–879	835–1021	755–923
	Motor frame size	56	56	184T	184T
	Fan Qty / Type	2 / Centrifugal	2 / Centrifugal	2 / Centrifugal	2 / Centrifugal
	Fan Diameter (in)	18 x 15/15 X 11	18 x 15/15 X 11	18 x 15/15 X 11	18 x 15/15 X 11
High Static	Motor Qty / Drive type	1 / Belt	1 / Belt	1 / Belt	1 / Belt
	Max BHP	4.9	6.5	8.7	8.7
	RPM range	746–912	882–1078	941–1176	827–1010
	Motor frame size	56	184T	213T	213T
	Fan Qty / Type	2 / Centrifugal	2 / Centrifugal	2 / Centrifugal	2 / Centrifugal
	Fan Diameter (in)	18 x 15/15 X 11	18 x 15/15 X 11	18 x 15/15 X 11	18 x 15/15 X 11
Cond. Coil (Circuit A)					
	Coil type	RTPF	RTPF	RTPF	RTPF
	Coil Length (in)	70	72	82	95
	Coil Height (in)	44	44	52	52
	Rows / FPI (fins per inch)	2 /17	2 /17	2 /17	2 /17
	Total face area (ft2)	21.4	22.0	29.6	34.3
Cond. Coil (Circuit B)					
	Coil type	RTPF	RTPF	RTPF	RTPF
	Coil Length (in)	70	64	80	95
	Coil Height (in)	44	44	52	52
	Rows / FPI (fins per inch)	2 /17	2 /17	2 /17	2 /17
	Total face area (ft2)	21.4	19.5	29.6	34.3
Cond. fan / motor					
	Qty / Motor drive type	3 / direct	4 / direct	4/ direct	6 / direct
	Motor HP / RPM	1/4 / 1100	1/4 / 1100	1/4 / 1100	1/4 / 1100
	Fan diameter (in)	22	22	22	22
Filters					
	RA Filter # / size (in)	6 / 20 x 25 x 2	6 / 20 x 25 x 2	9 / 16 x 25 x 2	9 / 16 x 25 x 2
	OA inlet screen # / size (in)	4 / 16 x 25 x 1	4 / 16 x 25 x 1	4 / 16 x 25 x 1	4 / 16 x 25 x 1

Table 7 – PHYSICAL DATA (HEATING) 15 – 25 TONS

RGH		181 – 183	210 – 213	240 – 243	300 – 303	
Gas Connection						
# of Gas Valves						
		1	1	1	1	
Nat. gas supply line press (in. w.g.)/(PSIG)						
		5 –13 / 0.18–0.47	5 –13 / 0.18–0.47	5 –13 / 0.18–0.47	5 –13 / 0.18–0.47	
Propane supply line press (in. w.g.)/(PSIG)						
		11–13 / 0.40–0.47	11–13 / 0.40–0.47	11–13 / 0.40–0.47	11–13 / 0.40–0.47	
Heat Anticipator Setting (Amps)						
1st stage						
		0.14	0.14	0.14	0.14	
2nd stage						
		0.14	0.14	0.14	0.14	
Natural Gas Heat						
# of stages / # of burners (total)						
		2 / 5	2 / 5	2 / 5	2 / 5	
LOW	Connection size					
		3/4" NPT	3/4" NPT	3/4" NPT	3/4" NPT	
	Rollout switch opens / closes					
	195 / 115	195 / 115	195 / 115	195 / 115		
Temperature rise range (F)						
	25 – 55	25 – 55	25 – 55	25 – 55		
# of stages / # of burners (total)						
	2 / 7	2 / 7	2 / 7	2 / 7		
MED	Connection size					
		3/4" NPT	3/4" NPT	3/4" NPT	3/4" NPT	
	Rollout switch opens / closes					
	195 / 115	195 / 115	195 / 115	195 / 115		
Temperature rise range (F)						
	30– 60	30– 60	30– 60	30– 60		
Connection size						
	2 / 10	2 / 10	2 / 10	2 / 10		
HIGH	# of stages / # of burners (total)					
		3/4" NPT	3/4" NPT	3/4" NPT	3/4" NPT	
	Rollout switch opens / closes					
	195 / 115	195 / 115	195 / 115	195 / 115		
Temperature rise range (F)						
	35– 65	35– 65	35– 65	35– 65		
Liquid Propane Heat						
# of stages / # of burners (total)						
	2 / 5	2 / 5	2 / 5	2 / 5		
LOW	Connection size					
		3/4" NPT	3/4" NPT	3/4" NPT	3/4" NPT	
	Rollout switch opens / closes					
	195 / 115	195 / 115	195 / 115	195 / 115		
Temperature rise range (F)						
	25 – 55	25 – 55	25 – 55	25 – 55		
# of stages / # of burners (total)						
	2 / 7	2 / 7	2 / 7	2 / 7		
MED	Connection size					
		3/4" NPT	3/4" NPT	3/4" NPT	3/4" NPT	
	Rollout switch opens / closes					
	195 / 115	196 / 115	197 / 115	198 / 115		
Temperature rise range (F)						
	30– 60	30– 60	30– 60	30– 60		
# of stages / # of burners (total)						
	2 / 10	2 / 10	2 / 10	2 / 10		
HIGH	Connection size					
		3/4" NPT	3/4" NPT	3/4" NPT	3/4" NPT	
	Rollout switch opens / closes					
	195 / 115	195 / 115	195 / 115	195 / 115		
Temperature rise range (F)						
	35– 65	35– 65	35– 65	35– 65		

BASE UNIT DIMENSIONS - RGH181/183

NOTES:

1. DIMENSIONS ARE IN INCHES, DIMENSIONS IN [] ARE IN MILLIMETERS.
2.  CENTER OF GRAVITY
3.  DIRECTION OF AIR FLOW

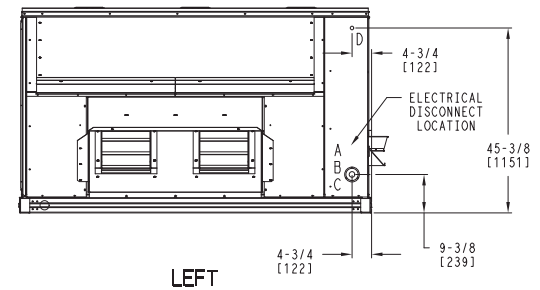
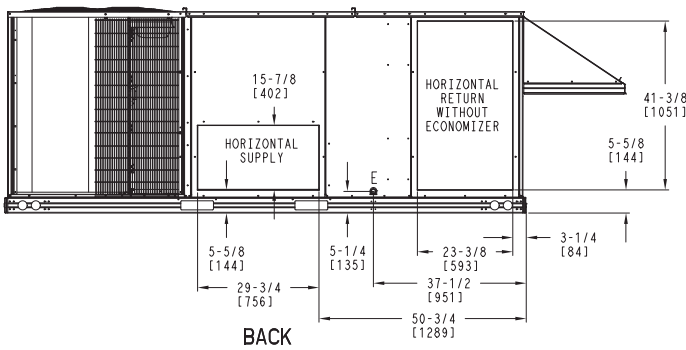
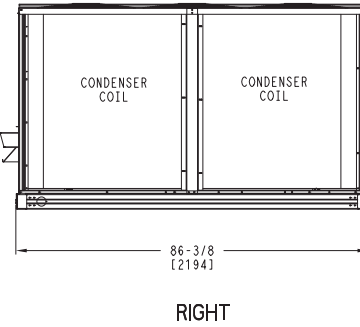
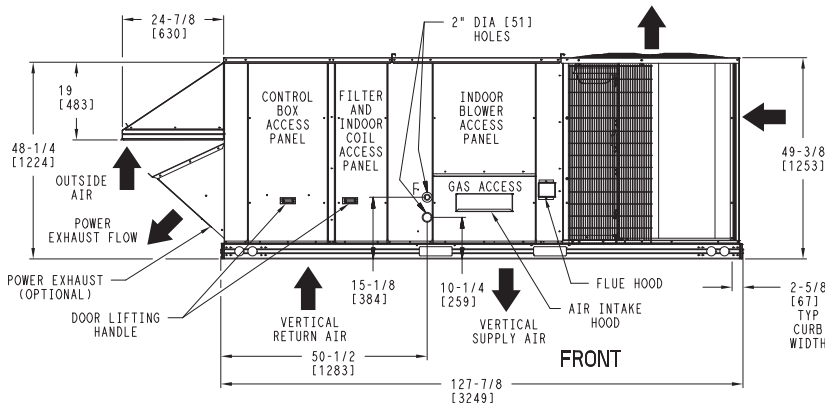
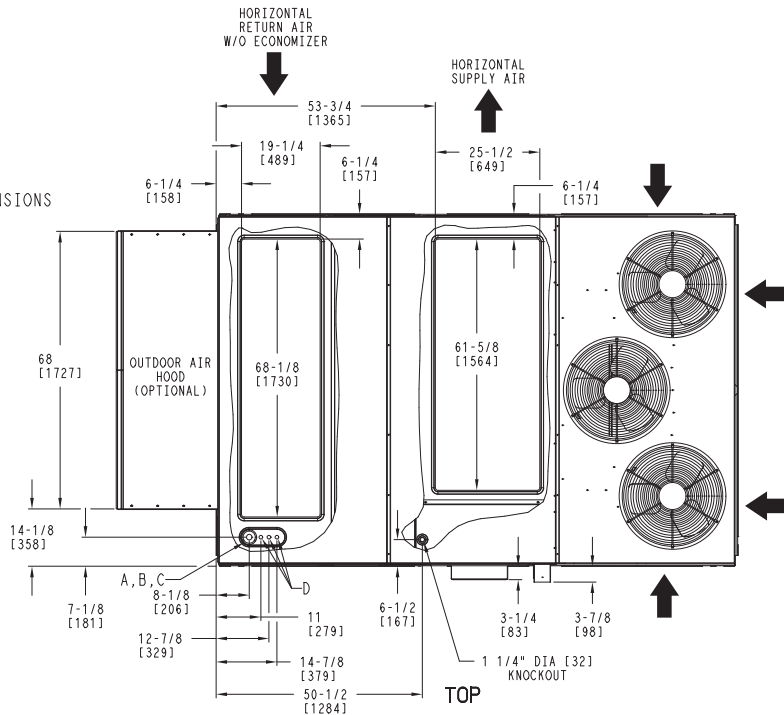

(HORIZONTAL DISCHARGE W/O ECON)
(WHEN ORDERED)

CONNECTION SIZES	
A	1 3/8" DIA [35] FIELD POWER SUPPLY KNOCKOUT
B	3" DIA [76] FIELD POWER SUPPLY KNOCKOUT
C	3 5/8" DIA [92] FIELD POWER SUPPLY KNOCKOUT
D	7/8" DIA [22] FIELD CONTROL WIRING HOLE
E	3/4"-14 NPT CONDENSATE DRAIN
F	3/4"-14 NPT GAS CONNECTION (NOT SHOWN)

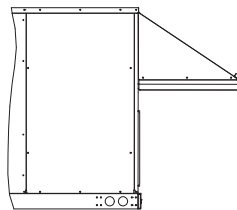

BACK

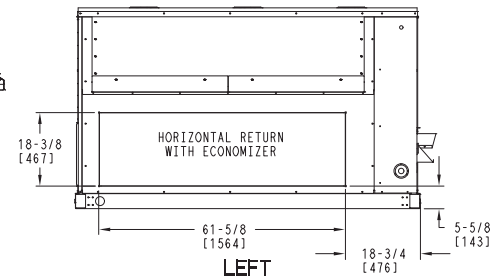

(HORIZONTAL DISCHARGE W/ ECON)
(WHEN ORDERED)

LEFT

WEIGHT & DIMENSIONS – RGH181/183 (cont.)

UNIT	STD UNIT WEIGHT *		CORNER WEIGHT (A)		CORNER WEIGHT (B)		CORNER WEIGHT (C)		CORNER WEIGHT (D)		C.G.		
	LBS.	KG.	LBS.	KG.	LBS.	KG.	LBS.	KG.	LBS.	KG.	X	Y	Z
15 Ton	1892	860	401	182	449	204	565	257	505	230	48 [1219]	67 3/8 [1711]	16 1/2 [419]

* STANDARD UNIT WEIGHT IS WITH LOW GAS HEAT AND WITHOUT PACKAGING.

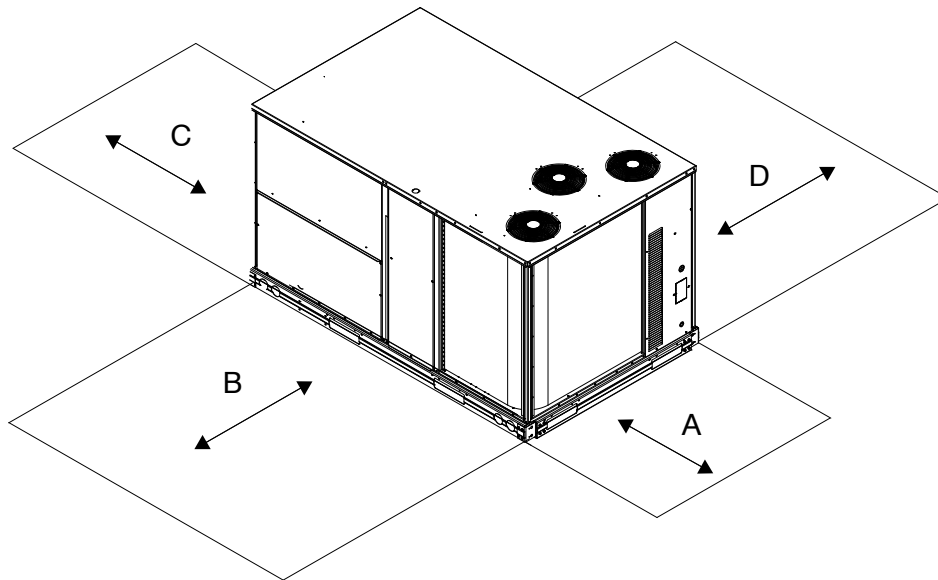
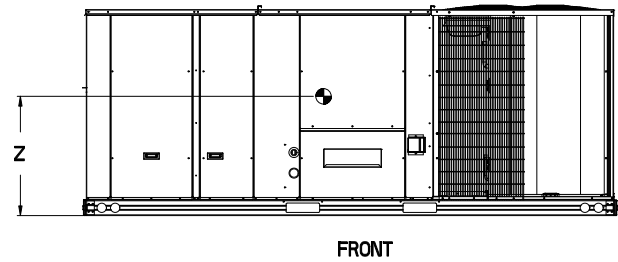
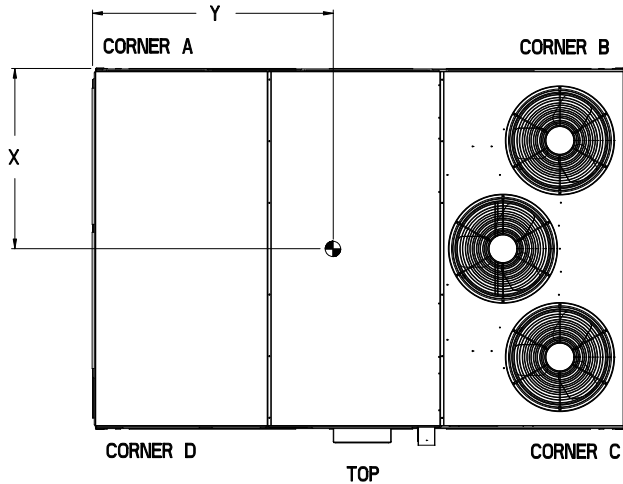

LOC	DIMENSION	CONDITION
A	36-in. (1219 mm)	Recommended clearance for airflow and service.
B	42-in. (1067 mm)	Recommended clearance for airflow and service.
C	18-in. (457 mm)	1. No CO. 2. No Economizer. 3. No field installed disconnect on economizer hood side (Factory-installed disconnect installed).
	36-in. (914 mm)	1. CO installed. 2. Vertical surface behind servicer is electrically non-conductive (e.g., wood, fiberglass).
	42-in. (1067 mm)	1. CO installed. 2. Vertical surface behind servicer is electrically conductive (e.g., metal, masonry)
	96-in. (2438 mm)	1. Economizer and/or Power Exhaust installed. 2. Check for sources of flue products within 10-ft of economizer fresh air intake.
D	42-in. (1067 mm)	Recommended clearance for service.

ROOF CURB DETAILS – RGH181/183

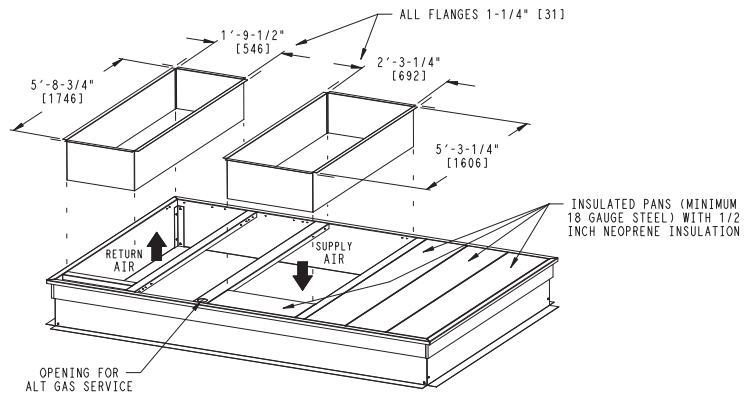
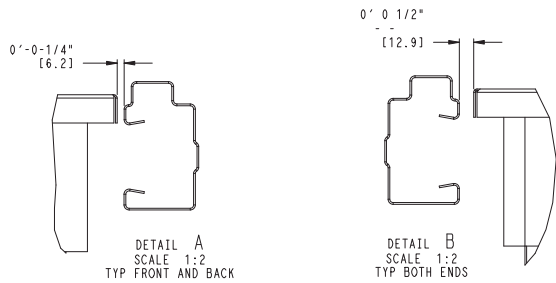
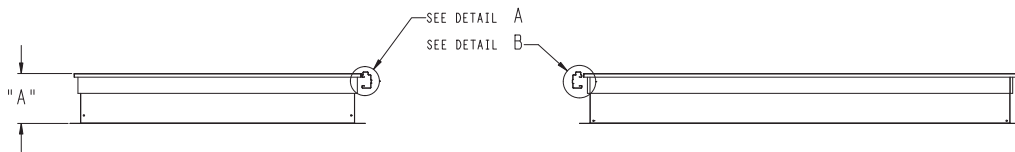
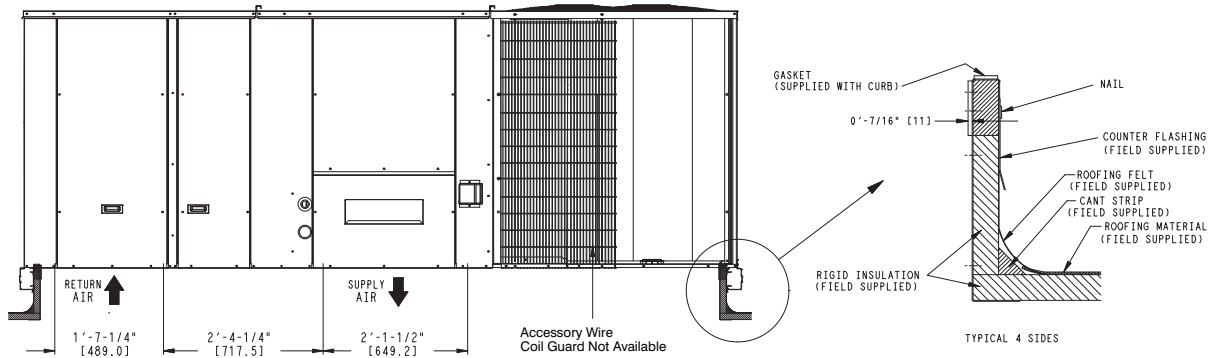
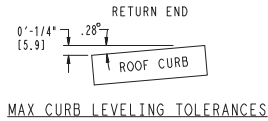
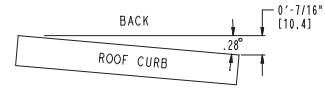
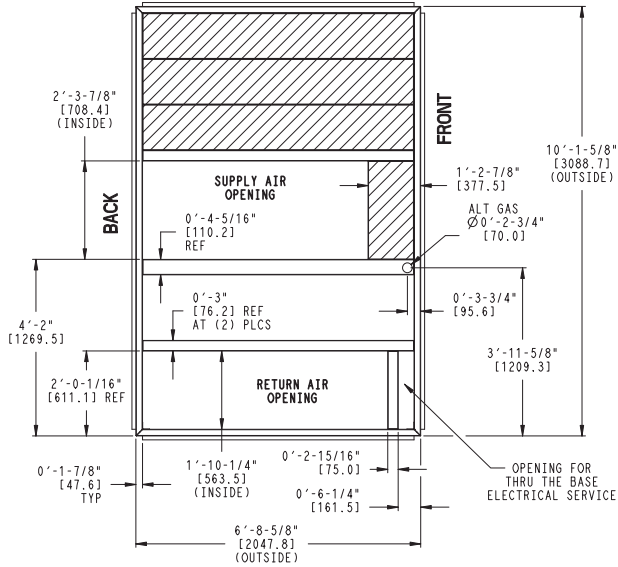

RoofCurb Accessory	A	Unit Size
CRRFCURB045A00	1' 2" [356]	15 Ton
CRRFCURB046A00	2' 0" [610]	

- NOTES:
1. Roofcurb accessory is shipped disassembled.
 2. Dimensions in. [] in millimeters.
 3. Roofcurb galvanized steel.
 4. Attach ductwork to curb (Flanges of duct rest on curb)
 5. Service clearance 4' on each side.
- ➡ Direction of airflow.



BASE UNIT DIMENSIONS - RGH210/213 - 240/243

NOTES:

1. DIMENSIONS ARE IN INCHES, DIMENSIONS IN [] ARE IN MILLIMETERS.
2.  CENTER OF GRAVITY
3.  DIRECTION OF AIR FLOW

CONNECTION SIZES	
A	1 3/8" DIA [35] FIELD POWER SUPPLY KNOCKOUT
B	3" DIA [76] FIELD POWER SUPPLY KNOCKOUT
C	3 5/8" DIA [92] FIELD POWER SUPPLY KNOCKOUT
D	7/8" DIA [22] FIELD CONTROL WIRING HOLE
E	3/4"-14 NPT CONDENSATE DRAIN
F	3/4"-14 NPT GAS CONNECTION (NOT SHOWN)

UNIT	G	H
17.5Ton	41-3/8 [1051]	49-3/8 [1253]
20Ton	49-3/8 [1253]	57-3/8 [1456]

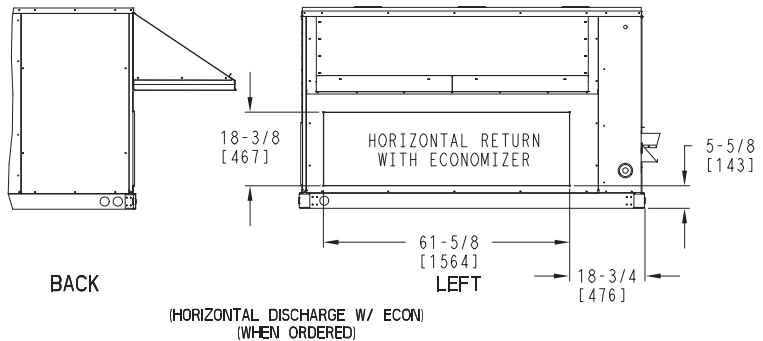
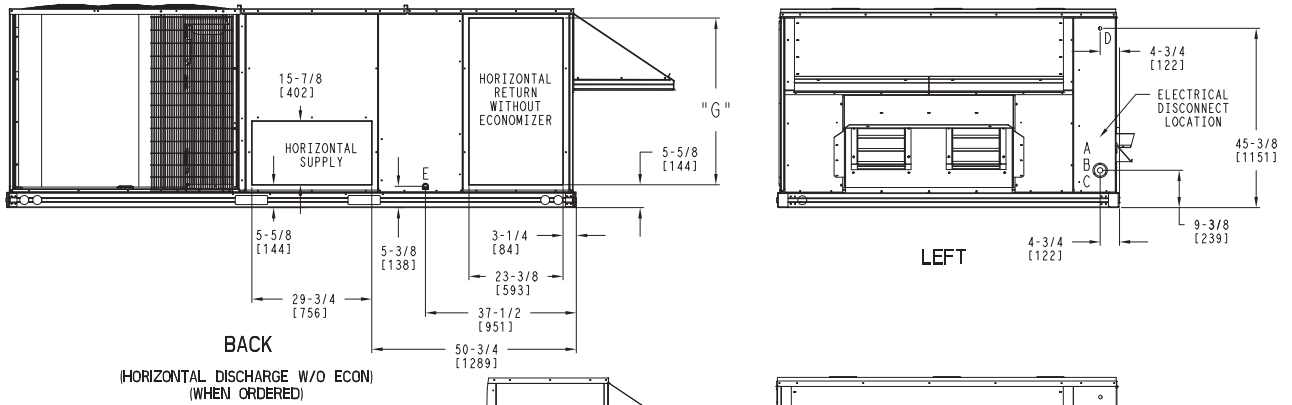
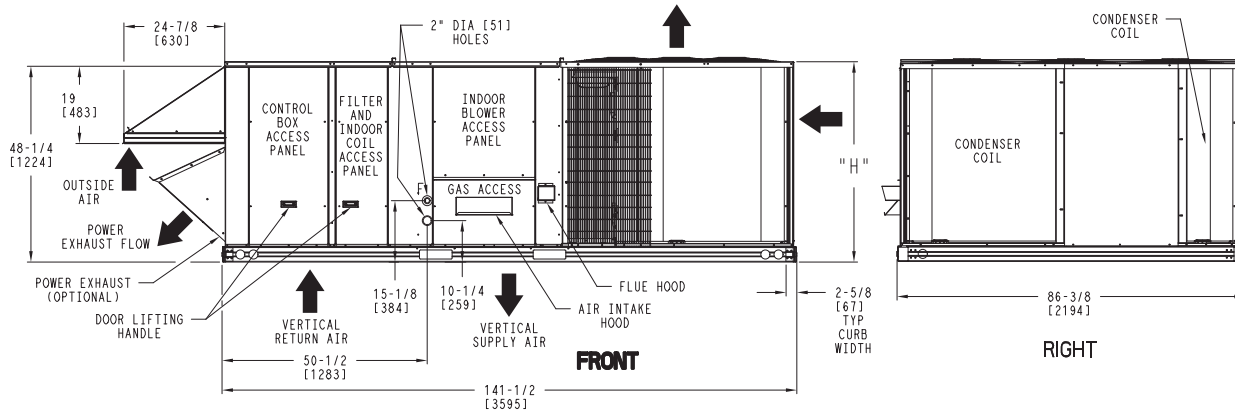
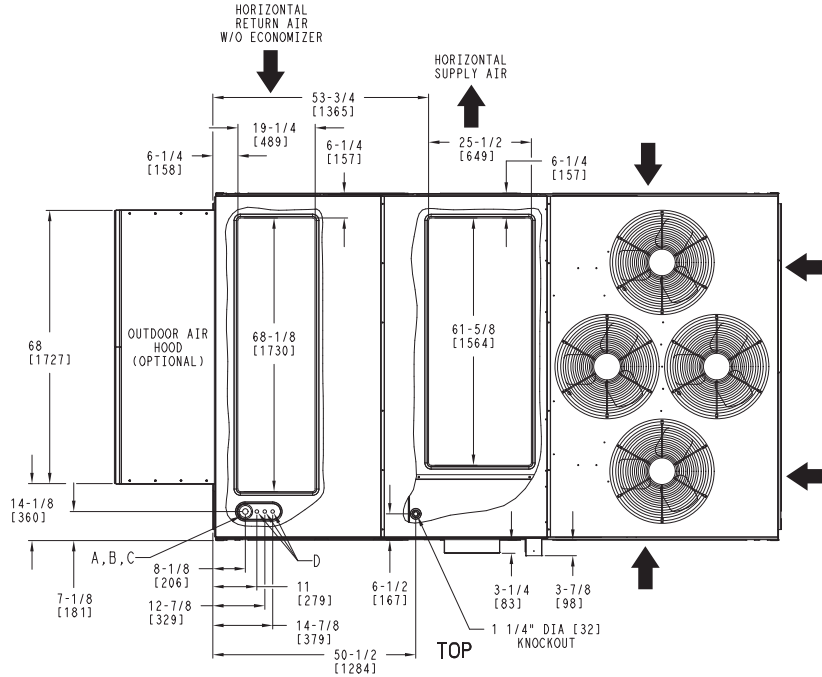

WEIGHT & CLEARANCE DIMENSIONS – RGH210/213 – 240/243 (cont.)

UNIT	STD. UNIT WEIGHT *		CORNER WEIGHT (A)		CORNER WEIGHT (B)		CORNER WEIGHT (C)		CORNER WEIGHT (D)		C.G.		
	LBS.	KG.	LBS.	KG.	LBS.	KG.	LBS.	KG.	LBS.	KG.	X	Y	Z
17.5 Ton	2102	956	474	215	390	177	593	269	582	265	47 1/2 [1207]	71 1/4 [1810]	16 1/2 [419]
20Ton	2247	1021	540	246	556	253	598	272	581	264	44 5/8 [1133]	71 5/8 [1819]	19 [483]

* STANDARD UNIT WEIGHT IS WITH LOW GAS HEAT AND WITHOUT PACKAGING.

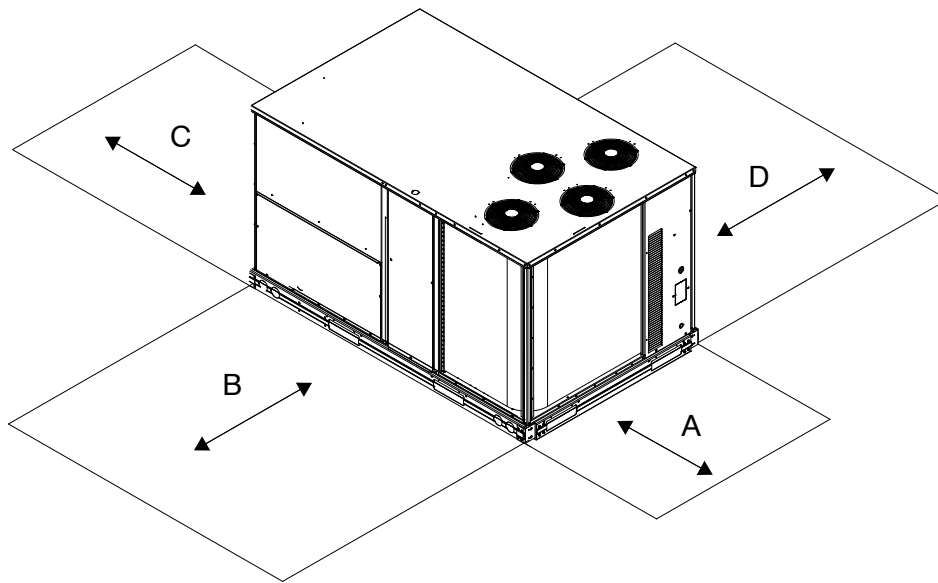
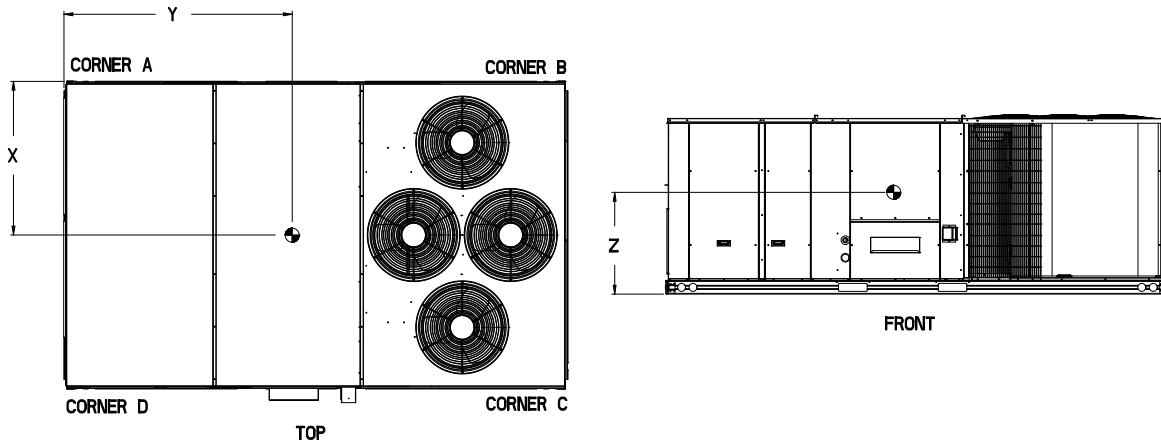

LOC	DIMENSION	CONDITION
A	36-in. (1219 mm)	Recommended clearance for airflow and service.
B	42-in. (1067 mm)	Recommended clearance for airflow and service.
C	18-in. (457 mm)	1. No CO. 2. No Economizer. 3. No field installed disconnect on economizer hood side (Factory-installed disconnect installed).
	36-in. (914 mm)	1. CO installed. 2. Vertical surface behind servicer is electrically non-conductive (e.g., wood, fiberglass).
	42-in. (1067 mm)	1. CO installed. 2. Vertical surface behind servicer is electrically conductive (e.g., metal, masonry)
	96-in. (2438 mm)	1. Economizer and/or Power Exhaust installed. 2. Check for sources of flue products within 10-ft of economizer fresh air intake.
D	42-in. (1067 mm)	Recommended clearance for service.

ROOF CURB DETAILS – RGH210/213 – 240/243

RoofCurb Accessory	A	Unit Size
CRRFCURB047A00	1' 2" [356]	17.5 ton
CRRFCURB048A00	2' 0" [610]	20 ton

NOTES:

1. Roofcurb accessory is shipped disassembled.
 2. Dimensions in. [] in millimeters.
 3. Roofcurb galvanized steel.
 4. Attach ductwork to curb (Flanges of duct rest on curb)
 5. Service clearance 4' on each side.
- ➡ Direction of airflow.

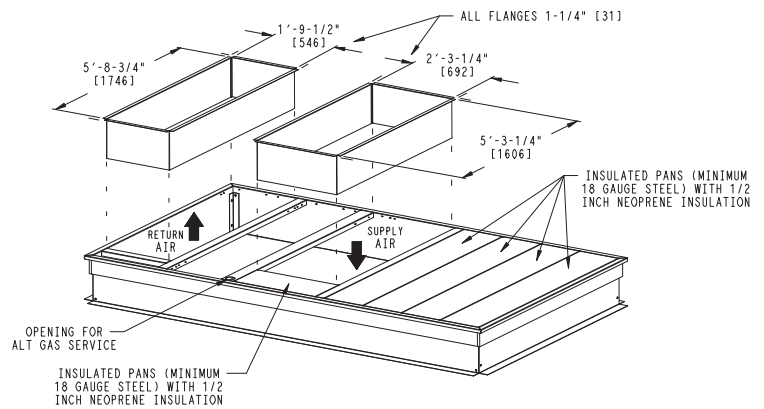
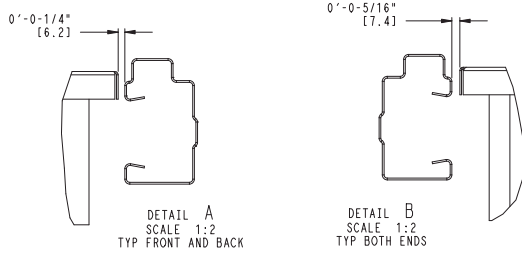
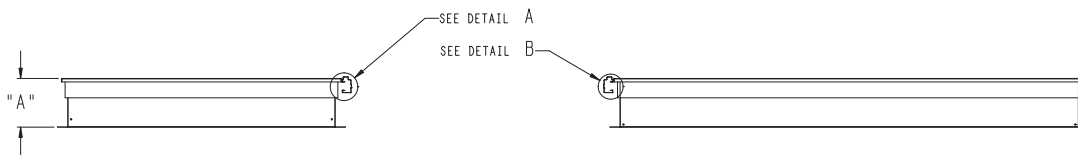
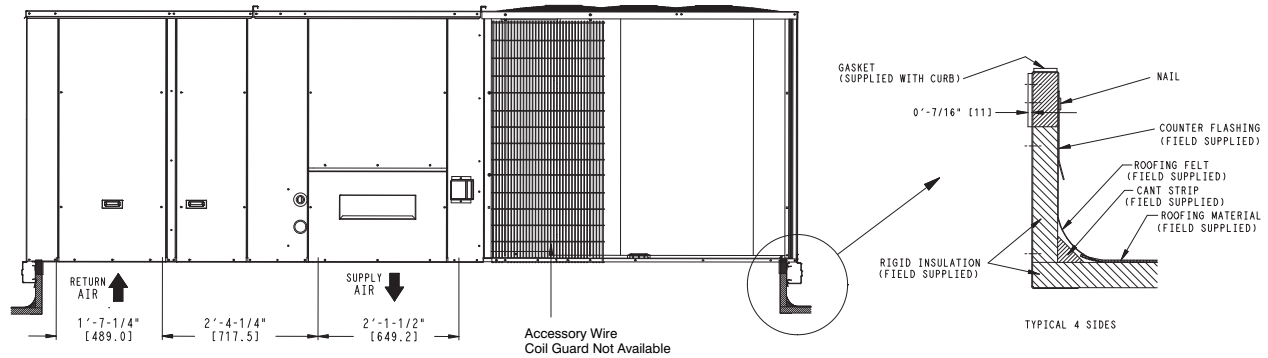
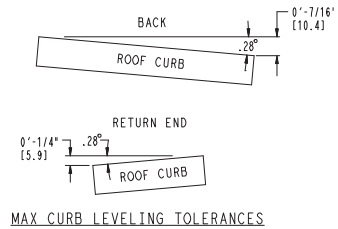
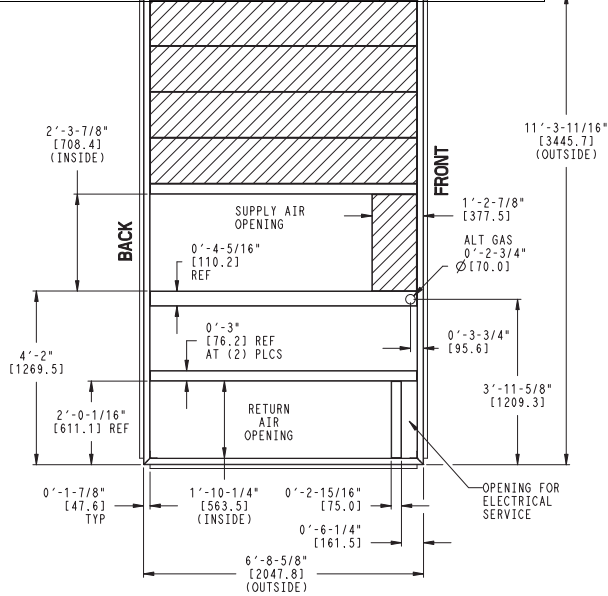

BASE UNIT DIMENSIONS - RGH300/303

CONNECTION SIZES	
A	1 3/8" DIA [35] FIELD POWER SUPPLY KNOCKOUT
B	3" DIA [76] FIELD POWER SUPPLY KNOCKOUT
C	3 5/8" DIA [92] FIELD POWER SUPPLY KNOCKOUT
D	7/8" DIA [22] FIELD CONTROL WIRING HOLE
E	3/4"-14 NPT CONDENSATE DRAIN
F	3/4"-14 NPT GAS CONNECTION (NOT SHOWN)

- NOTES:
1. DIMENSIONS ARE IN INCHES. DIMENSIONS IN () ARE IN MILLIMETERS.
 2. CENTER OF GRAVITY
 3. DIRECTION OF AIR FLOW

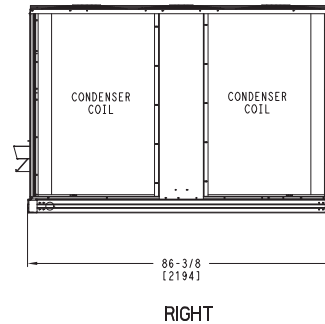
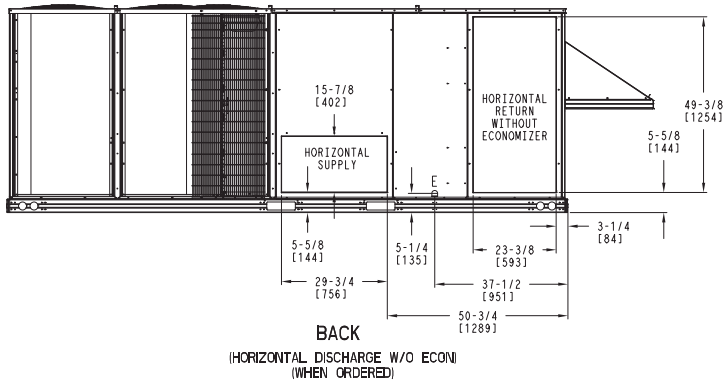
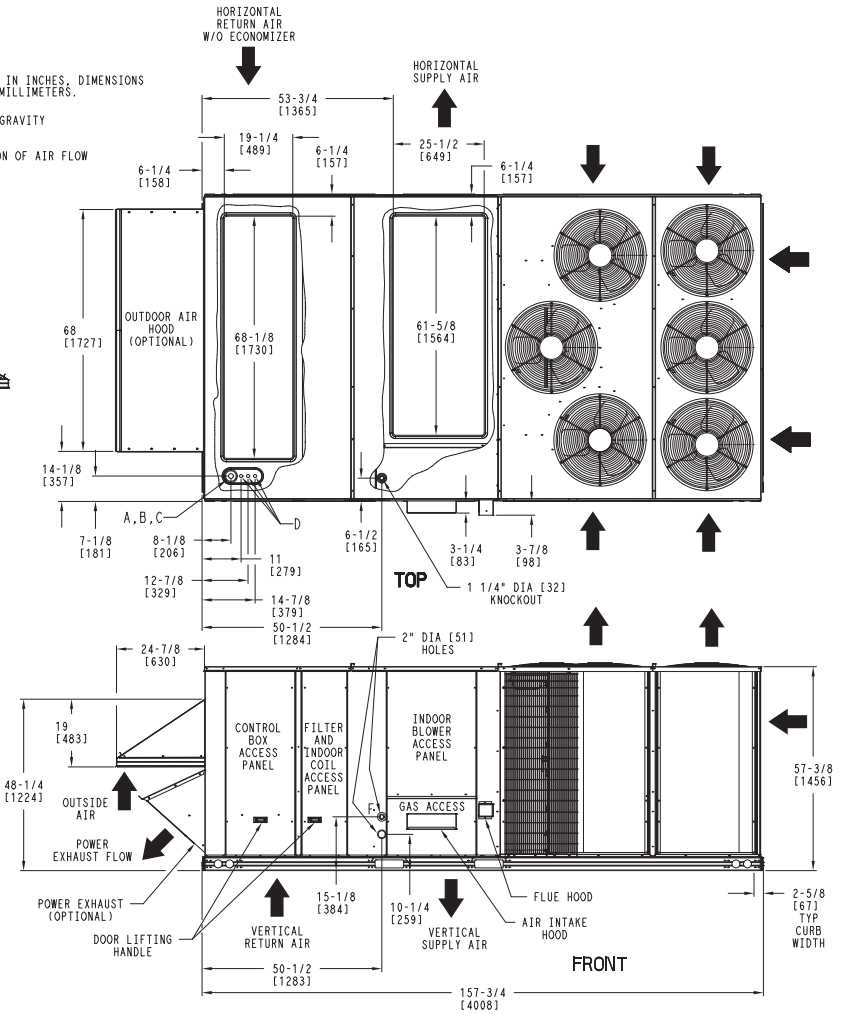
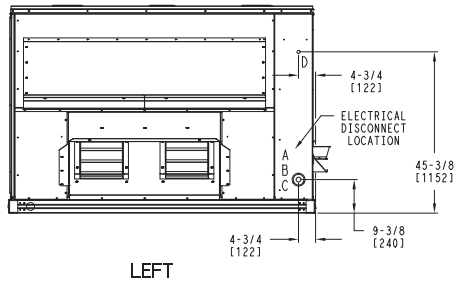
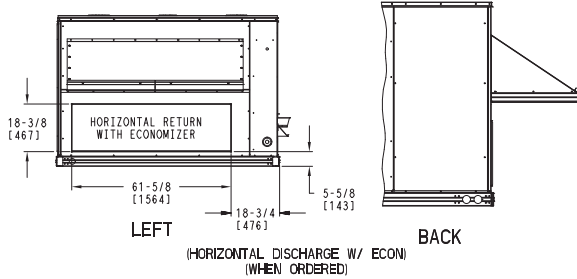

WEIGHT & CLEARANCE DIMENSIONS – RGH300/303 (cont.)

UNIT	STD UNIT WEIGHT *		CORNER WEIGHT (A)		CORNER WEIGHT (B)		CORNER WEIGHT (C)		CORNER WEIGHT (D)		C.G.		
	LBS.	KG.	LBS.	KG.	LBS.	KG.	LBS.	KG.	LBS.	KG.	X	Y	Z
25 Ton	2292	1042	577	262	559	254	583	265	602	274	44 [1118]	77 1/2 [1969]	19 [483]

* STANDARD UNIT WEIGHT IS WITH LOW GAS HEAT AND WITHOUT PACKAGING.

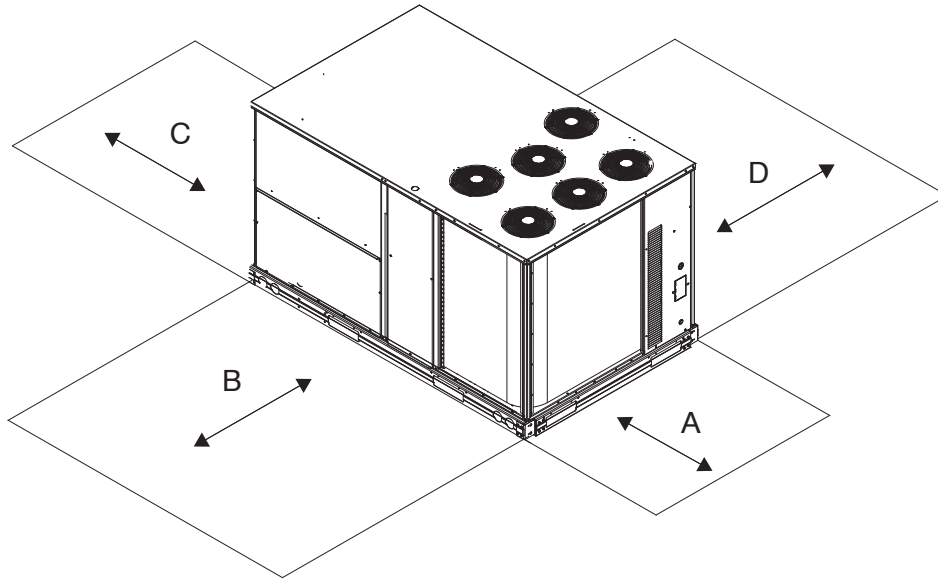
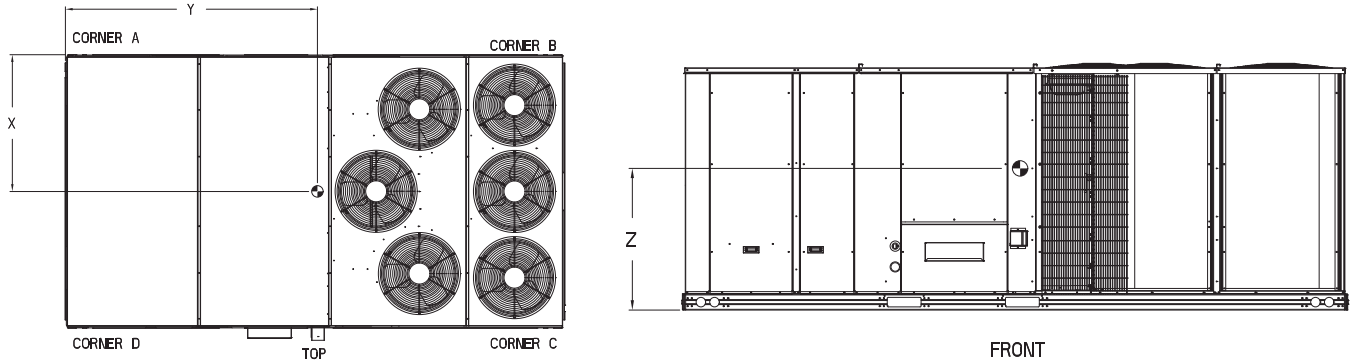

LOC	DIMENSION	CONDITION
A	36-in. (1219 mm)	Recommended clearance for airflow and service.
B	42-in. (1067 mm)	Recommended clearance for airflow and service.
C	18-in. (457 mm)	1. No CO. 2. No Economizer. 3. No field installed disconnect on economizer hood side (Factory-installed disconnect installed).
	36-in. (914 mm)	1. CO installed. 2. Vertical surface behind servicer is electrically non-conductive (e.g., wood, fiberglass).
	42-in. (1067 mm)	1. CO installed. 2. Vertical surface behind servicer is electrically conductive (e.g., metal, masonry)
	96-in. (2438 mm)	1. Economizer and/or Power Exhaust installed. 2. Check for sources of flue products within 10-ft of economizer fresh air intake.
D	42-in. (1067 mm)	Recommended clearance for service.

ROOF CURB DETAILS – RGH300/303

Roof Curb Accessory	A	Unit Size
CRRFCURB049A00	1' 2" [356]	25 ton
CRRFCURB050A00	2' 0" [610]	

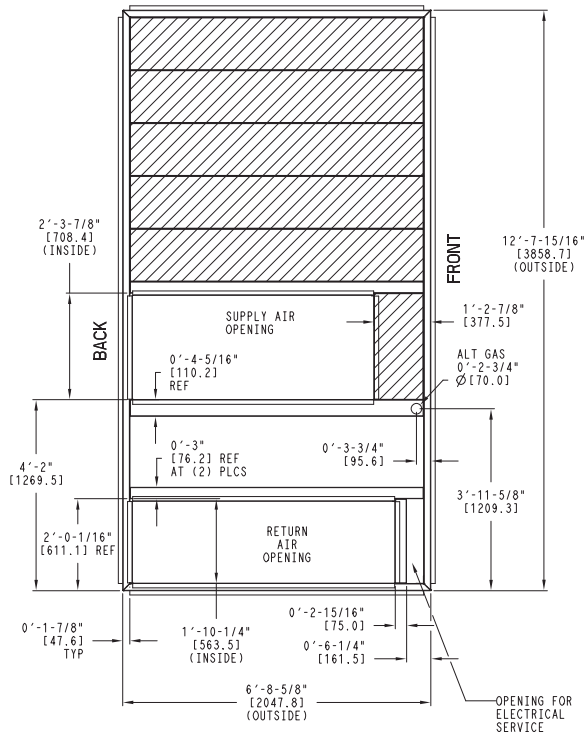

- NOTES:
- 1 ROOF CURB ACCESSORY IS SHIPPED UNASSEMBLED.
 - 2 BOLT HEADS TO BE ON INSIDE OF FLANGE. CLEARANCE IS (11) 0-0-7/16" TYP ALL CORNERS.
 - 3 DIMENSIONS IN [] ARE IN MILLIMETERS.
 - 4 ROOF CURB GALVANIZED STEEL.
 - 5 ATTACH DUCTWORK TO CURB (FLANGES ON DUCT REST ON CURB)
 - 6 SERVICE CLEARANCE 4 ft ON EACH SIDE
 - 7 GAS SERVICE PLATE IS PART OF A SEPERATELY SHIPPED ACCESSORY PACKAGE.
 - 8 GAS SERVICE PLATE CAN BE USED WITH EITHER ACCESSORY ROOFCURB.

➔ DIRECTION OF AIR FLOW

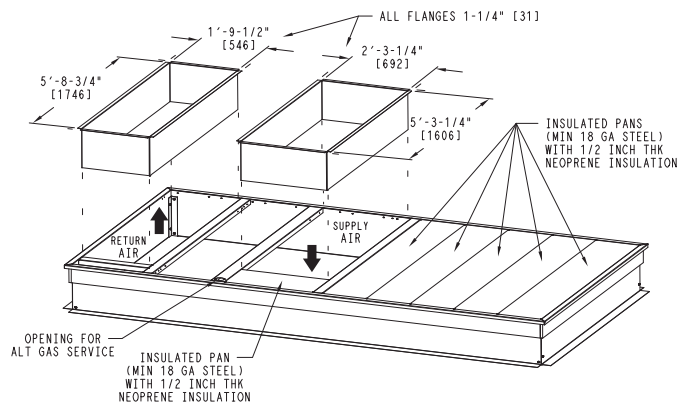
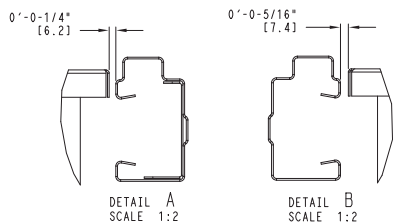
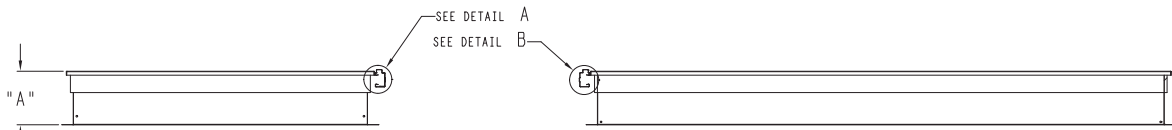
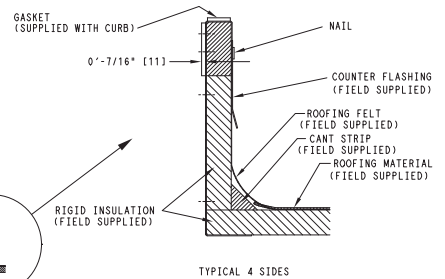
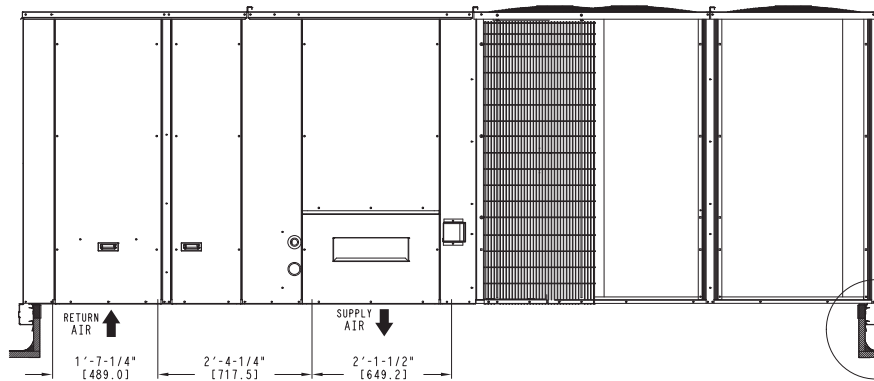
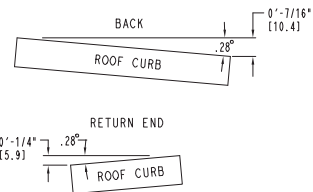

OPTIONS AND ACCESSORIES WEIGHT ADDERS

BASE UNIT WITH OPTIONS AND ACCESSORIES (Weight Adders)	MAX WEIGHT ADD							
	RGH181/183		RGH210/213		RGH240/243		RGH300/303	
	lb	kg	lb	kg	lb	kg	lb	kg
Base Unit Operating Weight	1892	858	2102	953	2247	1019	2292	1040
Hot Gas Reheat	83	38	83	38	88	40	92	42
Power Exhaust	125	57	125	57	125	57	125	57
Economizer	170	77	170	77	170	77	195	88
Copper Tube/Fin Evaporator Coil	110	50	110	50	135	61	161	73
Low Gas Heat	85	39	85	39	85	39	85	39
Medium Gas Heat	90	41	90	41	90	41	90	41
High Gas Heat	113	51	113	51	113	51	113	51
Flue Discharge Deflector	7	3	7	3	7	3	7	3
Roof Curb 14-in (356mm)	240	109	240	109	240	109	255	116
Roof Curb 24-in (610mm)	340	154	340	154	340	154	355	161
Louvered Hail Guard	60	27	60	27	120	54	150	68
CO ₂ sensor	5	2	5	2	5	2	5	2
Supply Smoke Detector	5	2	5	2	5	2	5	2
Fan/Filter Status Switch	2	1	2	1	2	1	2	1
Non-Fused Disconnect	15	7	15	7	15	7	15	7
Non-Powered Convenience Outlet	5	2	5	2	5	2	5	2
Enthalpy Sensor	2	1	2	1	2	1	2	1
Differential Enthalpy Sensor	3	1	3	1	3	1	3	1
Two Position Motorized Damper	50	23	50	23	50	23	65	29
Manual Damper	35	16	35	16	35	16	40	18
Field Filter Track 4-in (102mm)	12	5	12	5	12	5	18	8
MotorMaster Controller	35	16	35	16	35	16	35	16
Standard Static Motor/Drive	0	0	0	0	0	0	0	0
Medium Static Motor/Drive	5	2	6	3	6	3	6	3
High Static Motor/Drive	11	5	12	5	16	7	16	7
Barometric Relief Hood (Horizontal)	25	11	25	11	25	11	25	11
2 Speed VFD Drive Motor System	20	9	20	9	20	9	20	9

APPLICATION DATA

Min operating ambient temp (cooling):

In mechanical cooling mode, your rooftop unit can safely operate down to an outdoor ambient temperature of 35°F (2°C). It is possible to provide cooling at lower outdoor ambient temperatures by using less outside air, economizers, and/or accessory low ambient kits.

Max operating ambient temp (cooling):

The maximum operating ambient temperature for cooling mode is 125°F (52°C). While cooling operation above 125°F (52°C) may be possible, it could cause either a reduction in performance, reliability, or a protective action by the unit's internal safety devices.

Min mixed air temp (heating):

Using the factory settings, the minimum temperatures for the mixed air (the combined temperature of the warm return air and the cold outdoor air) entering the dimpled, gas heat exchangers are:

<u>Aluminized</u>	<u>Stainless Steel</u>
50°F (10°C) continuous	40°F (4°C) continuous
45°F (7°C) intermittent	35°F (2°C) intermittent

Operating at lower mixed-air temperatures may be possible, if a field-supplied, outdoor air thermostat initiates both heat stages when the temperature is less than the minimum temperatures listed above. Please contact your local representative for assistance.

Min and max airflow (heating and cooling):

To maintain safe and reliable operation of your rooftop, operate within the heating airflow limits during heating mode and cooling airflow limits during cooling mode. Operating above the max may cause blow-off, undesired airflow noise, or airflow related problems with the rooftop unit. Operating below the min may cause problems with coil freeze-up and unsafe heating operation. Heating and cooling limitations differ when evaluating operating CFM, the minimum value is the HIGHER of the cooling and heating minimum CFM values published in Table 5 and the maximum value is the LOWER of the cooling and heating minimum values published in Table 5.

Heating-to-cooling changeover:

This unit will automatically change from heating to cooling mode when using a thermostat with an auto-change-over feature.

Airflow:

All units are draw-through in cooling mode and blow-through in heating mode.

Outdoor air application strategies:

Economizers reduce operating expenses and compressor run time by providing a free source of cooling and a means of ventilation to match application changing needs. In fact, they should be considered for most applications. Also, consider the various economizer control methods and their benefits, as well as sensors required to accomplish your application goals.

Motor limits, break horsepower (BHP):

Due to internal design of units, the air path, and specially designed motors, the full horsepower (maximum continuous BHP) band can be used with the utmost confidence. There is no need for extra safety factors, as motors are designed and rigorously tested to use the entire, listed BHP range without either nuisance tripping or premature motor failure.

Propane heating:

Propane has different physical qualities than natural gas. As a result, propane requires different fuel to air mixture. To optimize the fuel/air mixture for propane, a kit with different burner orifices in an easy to install accessory. To select the correct burner orifices or determine the heat capacity for a propane application, use either the selection software, or the unit's service manual.

High altitude heating:

High altitudes have less oxygen, which affects the fuel/air mixture in heat exchangers. In order to maintain a proper fuel/air mixture, heat exchangers operating in altitudes above 2000 ft (610 m) require different orifices. To select the correct burner orifices or determine the heat capacity for a high altitude application, use either the selection software, or the unit's service manual.

High altitudes have less oxygen, which means heat exchangers need less fuel. The new gas orifices in this field-installed kit make the necessary adjustment for high altitude applications. They restore the optimal fuel to air mixture and maintain healthy combustion on altitudes above 2000 ft (610 m).

NOTE: Typical natural gas heating value ranges from 975 to 1050 Btu/ft³ at sea level nationally. The heating value goes down approximately 1.7% per every thousand feet elevation. Standard factory orifices can typically be used up to 2000 ft (610m) elevation without any operational issues.

NOTE: For installations in Canada, the input rating should be derated by 10% for altitudes from 2000 ft (610m) to 4500 ft (1372m) above sea level.

Sizing a rooftop

While an air conditioner needs to have enough capacity to meet the design loads, it doesn't need excess capacity. In fact, excess capacity typically results in very poor part load performance and humidity control.

Using higher design temperatures than ASHRAE recommends for your location, adding "safety factors" to the calculated load, are all signs of oversizing air conditioners. Oversizing the air conditioner leads to poor humidity control, reduced efficiency, higher utility bills, larger indoor temperature swings, excessive noise, and increased wear and tear on the air conditioner.

Rather than oversizing an air conditioner, engineers should "right-size" or even slightly undersize air conditioners. Correctly sizing an air conditioner controls humidity better; promotes efficiency; reduces utility bills; extends equipment life, and maintains even, comfortable temperatures.

Low ambient applications

The optional economizer can adequately cool your space by bringing in fresh, cool outside air. In fact, when so equipped, accessory low-ambient kit may not be necessary. In low ambient conditions, unless the outdoor air is excessively humid or contaminated, economizer-based "free cooling" is the preferred less costly and energy conscious method.

In low ambient applications where outside air might not be desired (such as contaminated or excessively humid outdoor environments), your rooftop can operate to ambient temperatures down to -20°F (-29°C) using the recommended accessory Motormaster low ambient controller or down to 25°F (-4°C) with the field installed Winter Start Package.

APPLICATION DATA (CONT.)

→ 2 Speed Drive System with Variable Frequency Drive (VFD)

The 2 speed drive system utilizes a Variable Frequency Drive (VFD) to automatically adjust the indoor fan motor speed in sequence with the units cooling operation. Per ASHRAE 90.1 2016 standard, during the first stage of cooling operation the VFD will adjust the fan motor to provide 2/3rd of the total cfm established for the unit. When a call for the second stage of cooling is required, the VFD will allow the total cfm for the unit established (100%). During the heating mode, the VFD will allow total design cfm (100%) operation and during the ventilation mode the VFD will allow operation to 2/3rd of total cfm.

The VFD used in 2 speed drive system has soft start capabilities to slowly ramp up the speeds, thus eliminating any high inrush air volume during initial start-up. It also has internal over current protection for the fan motor and a field installed display kit that allows adjustment and in depth diagnostics of the VFD.

This 2 speed drive system is available on models with 2-stage cooling operation with electrical mechanical controls. Both space sensor and conventional thermostats controls can be used to provide accurate control in any application.

The 2 speed drive system is very flexible for initial fan performance set up and adjustment. The standard factory shipped VFD is pre programmed to automatically stage the fan speed between the first and second stage of cooling. The unit fan performance static pressure and cfm can be easily adjusted using the traditional means of pulley adjustments. The other means to adjust the unit static and cfm performance is to utilize the field installed display module and adjust the frequency and voltage in the VFD to required performance requirements. In either case, once set up the VFD will automatically adjust the speed between the cooling stage operation.

Table 8 – COOLING CAPACITIES 15 TONS (2 Stage Cooling)

RGH181/183				AMBIENT TEMPERATURE															
				85			95			105			115			125			
				EA (dB)			EA (dB)			EA (dB)			EA (dB)			EA (dB)			
				75	80	85	75	80	85	75	80	85	75	80	85	75	80	85	
4500 CFM	EAT (wb)	58	TC	158.3	158.3	179.2	152.6	152.6	172.9	146.6	146.6	166.1	140.2	140.2	158.8	133.2	133.2	150.8	
			SHC	137.3	158.3	179.2	132.4	152.6	172.9	127.2	146.6	166.1	121.6	140.2	158.8	115.5	133.2	150.8	
		62	TC	166.8	166.8	169.0	159.5	159.5	165.6	151.8	151.8	161.9	143.6	143.6	157.9	134.9	134.9	153.4	
			SHC	123.1	146.1	169.0	119.7	142.6	165.6	116.1	139.0	161.9	112.3	135.1	157.9	108.2	130.8	153.4	
		67	TC	182.9	182.9	182.9	174.9	174.9	174.9	166.3	166.3	166.3	157.2	157.2	157.2	147.6	147.6	147.6	
			SHC	100.0	123.1	146.1	96.7	119.8	142.8	93.2	116.3	139.4	89.7	112.7	135.7	85.9	108.9	131.9	
	72	TC	200.5	200.5	200.5	191.6	191.6	191.6	182.2	182.2	182.2	172.2	172.2	172.2	161.7	161.7	161.7		
		SHC	76.1	99.5	122.8	72.9	96.2	119.5	69.5	92.8	116.1	66.0	89.3	112.5	62.4	85.6	108.8		
	76	TC	–	215.4	215.4	–	205.8	205.8	–	195.6	195.6	–	184.8	184.8	–	173.6	173.6		
		SHC	–	80.2	105.0	–	77.1	101.7	–	73.7	98.2	–	70.2	94.5	–	66.7	90.7		
	5250 CFM	EAT (wb)	58	TC	166.7	166.7	188.8	160.6	160.6	181.9	154.0	154.0	174.4	147.0	147.0	166.5	139.5	139.5	157.9
				SHC	144.6	166.7	188.8	139.3	160.6	181.9	133.6	154.0	174.4	127.6	147.0	166.5	121.0	139.5	157.9
62			TC	172.0	172.0	185.1	164.3	164.3	181.2	156.3	156.3	177.0	147.8	147.8	172.4	139.6	139.6	164.3	
			SHC	132.5	158.8	185.1	128.9	155.1	181.2	125.0	151.0	177.0	120.9	146.6	172.4	114.9	139.6	164.3	
67			TC	188.3	188.3	188.3	179.7	179.7	179.7	170.7	170.7	170.7	161.0	161.0	161.0	150.9	150.9	150.9	
			SHC	106.1	132.7	159.3	102.8	129.3	155.9	99.3	125.8	152.4	95.6	122.1	148.6	91.7	118.2	144.7	
72		TC	206.1	206.1	206.1	196.7	196.7	196.7	186.7	186.7	186.7	176.2	176.2	176.2	165.3	165.3	165.3		
		SHC	78.8	105.6	132.5	75.5	102.3	129.1	72.1	98.8	125.6	68.5	95.2	121.9	64.8	91.4	118.0		
76		TC	–	221.2	221.2	–	211.0	211.0	–	200.3	200.3	–	189.0	189.0	–	177.2	177.2		
		SHC	–	83.6	111.7	–	80.3	108.2	–	76.9	104.6	–	73.3	100.9	–	69.7	97.1		
6000 CFM		EAT (wb)	58	TC	173.8	173.8	196.8	167.2	167.2	189.4	160.2	160.2	181.4	152.7	152.7	173.0	144.7	144.7	163.8
				SHC	150.8	173.8	196.8	145.1	167.2	189.4	139.0	160.2	181.4	132.5	152.7	173.0	125.5	144.7	163.8
	62		TC	176.3	176.3	199.5	168.5	168.5	194.9	160.5	160.5	188.9	152.9	152.9	179.9	144.8	144.8	170.4	
			SHC	140.9	170.2	199.5	136.9	165.9	194.9	132.1	160.5	188.9	125.8	152.9	179.9	119.2	144.8	170.4	
	67		TC	192.3	192.3	192.3	183.4	183.4	183.4	173.9	173.9	173.9	164.0	164.0	164.0	153.4	153.4	156.9	
			SHC	112.0	142.0	172.0	108.5	138.5	168.5	104.9	134.9	164.8	101.2	131.1	161.0	97.2	127.1	156.9	
	72	TC	210.4	210.4	210.4	200.6	200.6	200.6	190.2	190.2	190.2	179.3	179.3	179.3	167.9	167.9	167.9		
		SHC	81.2	111.4	141.7	77.9	108.0	138.2	74.4	104.5	134.6	70.7	100.8	130.8	67.0	96.9	126.9		
	76	TC	–	225.6	225.6	–	215.0	215.0	–	203.8	203.8	–	192.1	192.1	–	180.0	180.0		
		SHC	–	86.7	117.9	–	83.3	114.5	–	79.9	110.8	–	76.3	107.1	–	72.6	103.2		
	6750 CFM	EAT (wb)	58	TC	179.8	179.8	203.7	172.9	172.9	195.8	165.5	165.5	187.4	157.5	157.5	178.4	149.0	149.0	168.8
				SHC	156.0	179.8	203.7	150.0	172.9	195.8	143.5	165.5	187.4	136.7	157.5	178.4	129.3	149.0	168.8
62			TC	180.5	180.5	210.7	173.0	173.0	203.6	165.6	165.6	194.9	157.7	157.7	185.5	149.1	149.1	175.5	
			SHC	147.6	179.2	210.7	142.4	173.0	203.6	136.3	165.6	194.9	129.8	157.7	185.5	122.8	149.1	175.5	
67			TC	195.6	195.6	195.6	186.2	186.2	186.2	176.5	176.5	176.8	166.2	166.2	172.7	155.4	155.4	168.4	
			SHC	117.5	150.8	184.1	114.0	147.3	180.5	110.4	143.6	176.8	106.5	139.6	172.7	102.4	135.4	168.4	
72		TC	213.8	213.8	213.8	203.6	203.6	203.6	192.9	192.9	192.9	181.6	181.6	181.6	169.9	169.9	169.9		
		SHC	83.5	117.0	150.5	80.1	113.5	147.0	76.5	109.9	143.3	72.8	106.1	139.4	69.1	102.3	135.5		
76		TC	–	229.1	229.1	–	218.1	218.1	–	206.6	206.6	–	194.6	194.6	–	182.1	182.1		
		SHC	–	89.6	124.0	–	86.2	120.5	–	82.7	116.8	–	79.0	113.0	–	75.2	109.0		
7500 CFM		EAT (wb)	58	TC	185.1	185.1	209.6	177.7	177.7	201.3	170.0	170.0	192.5	161.6	161.6	183.0	152.8	152.8	173.0
				SHC	160.6	185.1	209.6	154.2	177.7	201.3	147.5	170.0	192.5	140.2	161.6	183.0	132.5	152.8	173.0
	62		TC	185.2	185.2	218.0	177.9	177.9	209.3	170.1	170.1	200.2	161.8	161.8	190.4	152.9	152.9	179.9	
			SHC	152.5	185.2	218.0	146.4	177.9	209.3	140.0	170.1	200.2	133.2	161.8	190.4	125.8	152.9	179.9	
	67		TC	198.1	198.1	198.1	188.6	188.6	192.1	178.6	178.6	188.1	168.1	168.1	183.8	157.2	157.2	179.1	
			SHC	122.8	159.3	195.9	119.2	155.7	192.1	115.5	151.8	188.1	111.5	147.7	183.8	107.3	143.2	179.1	
	72	TC	216.6	216.6	216.6	206.1	206.1	206.1	195.1	195.1	195.1	183.5	183.5	183.5	171.6	171.6	171.6		
		SHC	85.6	122.3	159.0	82.2	118.8	155.5	78.6	115.2	151.7	74.9	111.3	147.8	71.1	107.4	143.8		
	76	TC	–	231.9	231.9	–	220.7	220.7	–	208.9	208.9	–	196.5	196.5	–	183.8	183.8		
		SHC	–	92.4	129.9	–	88.9	126.3	–	85.4	122.6	–	81.6	118.7	–	77.8	114.6		

LEGEND:

- Do not operate
- Cfm – Cubic feet per minute (supply air)
- EAT(db) – Entering air temperature (dry bulb)
- EAT(wb) – Entering air temperature (wet bulb)
- SHC – Sensible heat capacity
- TC – Total capacity

15 TONS – UNIT WITH HOT GAS REHEAT IN SUBCOOLING MODE										
Temp (F) Air Ent Condenser (Edb)		AIR ENTERING EVAPORATOR – CFM								
		4,500			6,000			7,500		
		Air Entering Evaporator --- Ewb (F)								
		72	67	62	72	67	62	72	67	62
75	TC	202.9	184.6	166.2	213.7	194.6	175.4	222.3	202.5	182.7
	SHC	91.9	112.4	132.9	106.1	126.4	146.8	117.5	137.7	158.0
	kW	10.19	10.12	9.78	10.51	10.19	9.95	10.61	10.36	10.12
85	TC	189.8	171.8	153.8	201.0	182.2	163.3	209.9	190.4	170.8
	SHC	75.9	101.0	126.2	91.2	116.3	141.3	103.4	128.4	153.5
	kW	11.57	11.49	11.15	11.88	11.56	11.32	11.98	11.73	11.49
95	TC	176.7	159.1	141.4	188.3	169.7	151.2	197.5	178.2	159.0
	SHC	59.8	89.7	119.6	76.2	106.1	135.9	89.4	119.2	149.0
	kW	12.87	12.81	12.47	13.20	12.88	12.64	13.30	13.05	12.81
105	TC	163.6	146.3	129.0	175.6	157.3	139.1	185.1	166.1	147.1
	SHC	43.8	78.4	112.9	61.3	95.9	130.4	75.3	109.9	144.4
	kW	14.05	14.00	13.65	14.39	14.07	13.82	14.40	14.24	14.00
115	TC	150.5	133.5	116.5	162.9	144.9	127.0	172.7	154.0	135.3
	SHC	27.7	67.0	106.3	46.4	85.7	125.0	61.3	100.6	133.4
	kW	15.44	15.36	15.02	15.75	15.43	15.19	15.85	15.60	15.36
125	TC	137.4	120.8	104.1	150.2	132.5	114.9	160.3	141.9	123.5
	SHC	11.7	55.7	99.6	31.4	75.5	112.9	47.3	91.3	123.0
	kW	16.77	16.71	16.37	17.10	16.78	16.54	17.20	16.95	16.71

15 TONS – UNIT WITH HOT GAS REHEAT IN HOT GAS REHEAT MODE										
Temp (F) Air Ent Condenser (Edb)		AIR ENTERING EVAPORATOR – Ewb (F)								
		75 Dry Bulb			75 Dry Bulb			75 Dry Bulb		
		62.5 Wet Bulb			64 Wet Bulb			65.3 Wet Bulb		
		(50% Relative)			(56% Relative)			(60% Relative)		
		Air Entering Evaporator – Cfm								
		4,500	6,000	7,500	4,500	6,000	7,500	4,500	6,000	7,500
80	TC	64.50	71.00	73.30	68.40	74.50	77.30	71.20	79.70	80.60
	SHC	12.60	24.90	36.80	6.80	13.70	23.90	-0.80	5.50	13.80
	kW	10.10	10.26	10.42	10.18	10.40	10.56	10.33	10.47	10.67
75	TC	66.60	73.10	75.60	70.50	76.60	79.50	73.20	80.80	82.90
	SHC	14.30	26.70	38.50	8.10	14.90	25.70	0.70	7.00	15.00
	kW	10.05	10.22	10.36	10.14	10.36	10.52	10.28	10.43	10.62
70	TC	68.70	75.10	77.40	72.50	78.60	81.40	75.20	82.80	84.90
	SHC	15.40	27.80	40.00	9.50	16.20	26.80	2.10	8.40	16.30
	kW	10.00	10.18	10.33	10.10	10.31	10.47	10.23	10.40	10.58
60	TC	72.80	79.30	81.60	76.70	82.80	85.70	79.40	86.90	88.80
	SHC	19.00	31.10	43.20	12.70	19.90	30.10	5.30	11.60	20.00
	kW	9.92	10.09	10.24	10.01	10.22	10.37	10.14	10.31	10.49
50	TC	76.80	83.40	85.70	80.80	86.90	89.70	83.50	90.90	92.80
	SHC	21.70	34.20	46.20	15.80	22.70	33.20	8.40	14.70	22.80
	kW	9.83	10.00	10.15	9.92	10.13	10.29	10.05	10.21	10.39
40	TC	80.90	87.30	89.60	84.90	90.80	93.60	87.40	94.80	96.70
	SHC	24.90	37.10	49.30	19.00	26.00	36.10	11.60	17.90	26.20
	kW	9.74	9.91	10.06	9.83	10.04	10.20	9.96	10.12	10.30

LEGEND

- Edb** – Entering Dry–Bulb
- Ewb** – Entering Wet–Bulb
- kW** – Compressor Motor Power Input
- ldb** – Leaving Dry–Bulb
- lwb** – Leaving Wet–Bulb
- SHC** – Sensible Heat Capacity (1000 Btuh) Gross
- TC** – Total Capacity (1000 Btuh) Gross

NOTES:

Direct interpolation is permissible. Do not extrapolate.
The following formulas may be used:

$$t_{ldb} = t_{edb} - \frac{\text{sensible capacity (Btuh)}}{1.10 \times \text{cfm}}$$

$$t_{lwb} = \text{Wet–bulb temperature corresponding to enthalpy of air leaving evaporator coil } (h_{lwb})$$

$$h_{lwb} = h_{ewb} - \frac{\text{total capacity (Btuh)}}{4.5 \times \text{cfm}}$$

Where: h_{ewb} = Enthalpy of air entering evaporator coil

Table 10 – COOLING CAPACITIES 17.5 TONS (2 Stage Cooling)

RGH210/213				AMBIENT TEMPERATURE															
				85			95			105			115			125			
				EA (dB)			EA (dB)			EA (dB)			EA (dB)			EA (dB)			
				75	80	85	75	80	85	75	80	85	75	80	85	75	80	85	
5250 CFM	EAT (wb)	58	TC	185.1	185.1	209.2	178.7	178.7	201.9	171.8	171.8	194.1	164.5	164.5	185.8	156.7	156.7	177.0	
			SHC	161.1	185.1	209.2	155.4	178.7	201.9	149.4	171.8	194.1	143.1	164.5	185.8	136.3	156.7	177.0	
		62	TC	193.8	193.8	199.5	185.6	185.6	195.4	176.9	176.9	191.1	167.7	167.7	186.4	158.2	158.2	181.1	
			SHC	145.6	172.6	199.5	141.7	168.6	195.4	137.6	164.4	191.1	133.2	159.8	186.4	128.3	154.7	181.1	
		67	TC	212.2	212.2	212.2	203.3	203.3	203.3	193.8	193.8	193.8	183.8	183.8	183.8	173.1	173.1	173.1	
			SHC	119.0	146.0	173.1	115.3	142.3	169.4	111.4	138.4	165.4	107.3	134.3	161.3	103.0	130.0	157.0	
	72	TC	232.3	232.3	232.3	222.7	222.7	222.7	212.4	212.4	212.4	201.6	201.6	201.6	190.1	190.1	190.1		
		SHC	91.5	118.8	146.2	87.9	115.2	142.5	84.1	111.4	138.7	80.2	107.4	134.6	76.0	103.2	130.4		
	76	TC	–	249.5	249.5	–	239.2	239.2	–	228.2	228.2	–	216.6	216.6	–	204.3	204.3		
		SHC	–	96.7	125.3	–	93.2	121.7	–	89.5	117.9	–	85.6	113.8	–	81.5	109.5		
	6125 CFM	EAT (wb)	58	TC	194.7	194.7	220.0	187.8	187.8	212.2	180.4	180.4	203.8	172.5	172.5	194.9	164.1	164.1	185.5
				SHC	169.4	194.7	220.0	163.3	187.8	212.2	156.9	180.4	203.8	150.1	172.5	194.9	142.8	164.1	185.5
62			TC	199.6	199.6	218.0	191.1	191.1	213.5	182.1	182.1	208.4	173.0	173.0	201.2	164.3	164.3	192.8	
			SHC	156.5	187.2	218.0	152.3	182.9	213.5	147.7	178.0	208.4	141.8	171.5	201.2	135.8	164.3	192.8	
67			TC	218.0	218.0	218.0	208.7	208.7	208.7	198.7	198.7	198.7	188.2	188.2	188.2	177.1	177.1	177.1	
			SHC	126.2	157.4	188.6	122.4	153.6	184.7	118.4	149.6	180.7	114.3	145.4	176.5	109.9	141.0	172.1	
72		TC	238.5	238.5	238.5	228.4	228.4	228.4	217.7	217.7	217.7	206.3	206.3	206.3	194.3	194.3	194.3		
		SHC	94.7	126.1	157.5	91.0	122.4	153.8	87.2	118.5	149.8	83.1	114.4	145.7	78.9	110.1	141.4		
76		TC	–	255.9	255.9	–	245.1	245.1	–	233.6	233.6	–	221.4	221.4	–	208.5	208.5		
		SHC	–	100.7	133.3	–	97.1	129.6	–	93.3	125.6	–	89.3	121.5	–	85.1	117.1		
7000 CFM		EAT (wb)	58	TC	202.7	202.7	229.1	195.4	195.4	220.8	187.5	187.5	211.9	179.2	179.2	202.5	170.3	170.3	192.4
				SHC	176.4	202.7	229.1	170.0	195.4	220.8	163.1	187.5	211.9	155.9	179.2	202.5	148.1	170.3	192.4
	62		TC	204.6	204.6	234.4	196.0	196.0	228.0	187.7	187.7	220.3	179.3	179.3	210.5	170.4	170.4	200.0	
			SHC	166.0	200.2	234.4	160.8	194.4	228.0	155.1	187.7	220.3	148.2	179.3	210.5	140.8	170.4	200.0	
	67		TC	222.5	222.5	222.5	212.8	212.8	212.8	202.4	202.4	202.4	191.5	191.5	191.5	180.0	180.0	186.4	
			SHC	133.0	168.2	203.4	129.2	164.3	199.5	125.1	160.3	195.4	120.9	156.0	191.0	116.4	151.4	186.4	
	72	TC	243.3	243.3	243.3	232.7	232.7	232.7	221.6	221.6	221.6	209.9	209.9	209.9	197.4	197.4	197.4		
		SHC	97.5	132.9	168.3	93.8	129.2	164.5	89.9	125.2	160.5	85.8	121.1	156.3	81.6	116.7	151.9		
	76	TC	–	260.8	260.8	–	249.6	249.6	–	237.7	237.7	–	225.1	225.1	–	211.7	211.7		
		SHC	–	104.4	140.8	–	100.7	137.0	–	96.9	133.0	–	92.8	128.8	–	88.5	124.4		
	7875 CFM	EAT (wb)	58	TC	209.6	209.6	236.8	201.8	201.8	228.1	193.6	193.6	218.8	184.8	184.8	208.9	175.5	175.5	198.3
				SHC	182.3	209.6	236.8	175.6	201.8	228.1	168.4	193.6	218.8	160.8	184.8	208.9	152.7	175.5	198.3
62			TC	209.8	209.8	246.2	202.0	202.0	237.1	193.8	193.8	227.4	185.0	185.0	217.1	175.6	175.6	206.1	
			SHC	173.4	209.8	246.2	167.0	202.0	237.1	160.1	193.8	227.4	152.9	185.0	217.1	145.1	175.6	206.1	
67			TC	226.1	226.1	226.1	216.0	216.0	216.0	205.4	205.4	209.4	194.2	194.2	204.8	182.4	182.4	199.9	
			SHC	139.6	178.6	217.7	135.6	174.7	213.7	131.5	170.5	209.4	127.1	166.0	204.8	122.5	161.2	199.9	
72		TC	247.0	247.0	247.0	236.2	236.2	236.2	224.7	224.7	224.7	212.7	212.7	212.7	199.9	199.9	199.9		
		SHC	100.2	139.5	178.8	96.5	135.7	174.9	92.5	131.7	170.9	88.4	127.5	166.6	84.1	123.1	162.1		
76		TC	–	264.7	264.7	–	253.1	253.1	–	240.9	240.9	–	227.9	227.9	–	–	–		
		SHC	–	107.9	148.1	–	104.2	144.3	–	100.2	140.2	–	96.1	135.9	–	–	–		
8750 CFM		EAT (wb)	58	TC	215.4	215.4	243.4	207.3	207.3	234.3	198.7	198.7	224.6	189.6	189.6	214.2	179.9	179.9	203.2
				SHC	187.4	215.4	243.4	180.3	207.3	234.3	172.9	198.7	224.6	164.9	189.6	214.2	156.5	179.9	203.2
	62		TC	215.5	215.5	253.0	207.5	207.5	243.5	198.9	198.9	233.4	189.7	189.7	222.7	180.0	180.0	211.2	
			SHC	178.1	215.5	253.0	171.5	207.5	243.5	164.4	198.9	233.4	156.8	189.7	222.7	148.8	180.0	211.2	
	67		TC	228.9	228.9	231.5	218.7	218.7	227.3	207.8	207.8	222.8	196.4	196.4	217.9	184.5	184.5	212.6	
			SHC	145.8	188.6	231.5	141.8	184.5	227.3	137.5	180.1	222.8	133.0	175.5	217.9	128.2	170.4	212.6	
	72	TC	250.1	250.1	250.1	239.0	239.0	239.0	227.3	227.3	227.3	214.9	214.9	214.9	201.8	201.8	201.8		
		SHC	102.8	145.8	188.9	99.0	142.0	185.0	95.0	137.9	180.9	90.8	133.7	176.5	86.4	129.2	172.0		
	76	TC	–	267.8	267.8	–	256.0	256.0	–	243.5	243.5	–	230.2	230.2	–	–	–		
		SHC	–	111.2	155.2	–	107.4	151.3	–	103.5	147.1	–	99.3	142.8	–	–	–		

LEGEND:

- Do not operate
- Cfm – Cubic feet per minute (supply air)
- EAT(db) – Entering air temperature (dry bulb)
- EAT(wb) – Entering air temperature (wet bulb)
- SHC – Sensible heat capacity
- TC – Total capacity

17.5 TONS – UNIT WITH HOT GAS REHEAT IN SUBCOOLING MODE										
Temp (F) Air Ent Condenser (Edb)		AIR ENTERING EVAPORATOR – CFM								
		5,250			7,000			8,750		
		Air Entering Evaporator --- Ewb (F)								
		72	67	62	72	67	62	72	67	62
75	TC	232.0	211.3	190.6	242.4	221.0	199.7	250.7	228.9	207.0
	SHC	110.9	133.7	156.4	127.6	150.3	173.0	141.1	163.7	186.4
	kW	12.45	12.16	11.81	12.74	12.41	12.02	12.93	12.51	12.18
85	TC	215.9	195.7	175.5	226.0	205.2	184.4	234.2	212.8	191.5
	SHC	90.6	118.8	147.0	108.4	136.6	164.9	122.7	151.0	179.2
	kW	13.48	13.20	12.88	13.77	13.47	13.07	13.96	13.58	13.23
95	TC	199.7	180.0	160.3	209.7	189.4	169.1	217.6	196.8	176.1
	SHC	70.3	104.0	137.7	89.2	123.0	156.7	104.4	138.2	172.1
	kW	14.60	14.25	13.94	14.89	14.51	14.15	15.08	14.63	14.31
105	TC	183.6	164.5	145.2	193.3	173.5	153.8	201.0	180.8	160.6
	SHC	50.0	89.1	128.3	70.0	109.3	148.6	86.0	125.5	158.6
	kW	15.64	15.36	15.01	15.93	15.60	15.21	16.12	15.72	15.37
115	TC	167.5	148.8	130.1	176.9	157.7	138.5	184.5	164.8	145.1
	SHC	29.7	74.3	118.9	50.7	95.6	138.1	67.7	112.7	145.1
	kW	16.70	16.38	15.82	16.98	16.63	16.03	17.17	16.75	16.19
125	TC	151.4	133.2	115.0	160.6	141.9	123.1	167.9	148.8	129.7
	SHC	9.4	59.5	109.6	31.5	81.9	123.0	49.3	100.0	129.7
	kW	17.71	17.39	17.09	18.01	17.65	17.30	18.20	17.76	17.46

17.5 TONS – UNIT WITH HOT GAS REHEAT IN HOT GAS REHEAT MODE										
Temp (F) Air Ent Condenser (Edb)		AIR ENTERING EVAPORATOR – Ewb (F)								
		75 Dry Bulb			75 Dry Bulb			75 Dry Bulb		
		62.5 Wet Bulb			64 Wet Bulb			65.3 Wet Bulb		
		(50% Relative)			(56% Relative)			(60% Relative)		
		Air Entering Evaporator – Cfm								
		5,250	7,000	8,750	5,250	7,000	8,750	5,250	7,000	8,750
80	TC	67.80	71.30	74.10	70.50	74.80	79.80	73.30	78.20	82.40
	SHC	9.00	26.50	41.70	2.20	13.20	26.90	-5.20	2.90	13.80
	kW	11.65	11.75	11.87	11.82	11.90	11.98	11.93	12.10	12.19
75	TC	72.50	76.00	78.80	75.00	79.20	84.30	78.00	83.00	86.90
	SHC	13.40	30.90	46.10	6.50	18.00	31.30	-2.10	7.20	17.90
	kW	11.44	11.54	11.66	11.61	11.68	11.75	11.70	11.86	11.95
70	TC	77.10	80.60	83.40	79.50	83.90	88.90	82.40	87.30	91.10
	SHC	17.60	34.70	49.90	10.80	22.20	35.10	3.20	11.50	22.20
	kW	11.22	11.33	11.45	11.40	11.46	11.54	11.49	11.64	11.75
60	TC	86.30	89.90	92.70	88.80	93.20	98.20	91.70	96.60	100.50
	SHC	26.20	43.20	58.40	19.40	30.80	43.60	11.60	20.10	30.70
	kW	10.76	10.86	10.98	10.93	11.00	11.07	11.03	11.18	11.28
50	TC	95.50	99.10	101.90	98.00	102.40	107.40	101.00	106.00	109.80
	SHC	34.80	51.80	67.00	28.00	39.40	52.20	20.10	28.70	39.40
	kW	10.33	10.43	10.55	10.50	10.52	10.63	10.59	10.74	10.85
40	TC	104.80	108.40	111.20	107.30	111.70	116.60	110.30	115.30	119.10
	SHC	43.40	60.40	75.60	36.60	48.00	60.80	28.80	37.30	47.90
	kW	9.87	9.97	10.09	10.04	10.11	10.18	10.14	10.28	10.40

LEGEND

- Edb** – Entering Dry–Bulb
- Ewb** – Entering Wet–Bulb
- kW** – Compressor Motor Power Input
- ldb** – Leaving Dry–Bulb
- lwb** – Leaving Wet–Bulb
- SHC** – Sensible Heat Capacity (1000 Btuh) Gross
- TC** – Total Capacity (1000 Btuh) Gross

NOTES:

.Direct interpolation is permissible. Do not extrapolate.
 .The following formulas may be used:

$$t_{ldb} = t_{edb} - \frac{\text{sensible capacity (Btuh)}}{1.10 \times \text{cfm}}$$

t_{lwb} = Wet–bulb temperature corresponding to enthalpy of air leaving evaporator coil (h_{lwb})

$$h_{lwb} = h_{ewb} - \frac{\text{total capacity (Btuh)}}{4.5 \times \text{cfm}}$$

Where: h_{ewb} = Enthalpy of air entering evaporator coil

Table 12 – COOLING CAPACITIES 20 TONS (2 Stage Cooling)

RGH240/243				AMBIENT TEMPERATURE														
				85			95			105			115			125		
				EA (dB)			EA (dB)			EA (dB)			EA (dB)			EA (dB)		
				75	80	85	75	80	85	75	80	85	75	80	85	75	80	85
6000 CFM	EAT (wb)	58	TC	214.4	214.4	242.5	207.0	207.0	234.2	199	199	225.1	190.2	190.2	215.2	180.6	180.6	204.3
			SHC	186.3	214.4	242.5	179.9	207.0	234.2	173	199	225.1	165.3	190.2	215.2	157.0	180.6	204.3
		62	TC	226.8	226.8	227.7	217.3	217.3	223.0	206.9	206.9	218	195.8	195.8	212.5	183.7	183.7	206.4
			SHC	167.0	197.3	227.7	162.4	192.7	223.0	157.6	187.8	218	152.3	182.4	212.5	146.6	176.5	206.4
		67	TC	248.4	248.4	248.4	237.9	237.9	237.9	226.6	226.6	226.6	214.3	214.3	214.3	201.0	201.0	201.0
			SHC	136.5	167.1	197.6	132.2	162.7	193.2	127.5	158	188.4	122.5	152.9	183.4	117.2	147.6	178.0
		72	TC	271.9	271.9	271.9	260.3	260.3	260.3	247.9	247.9	247.9	234.5	234.5	234.5	220.1	220.1	220.1
			SHC	105.1	136.0	167.0	100.8	131.7	162.5	96.3	127.1	157.9	91.4	122.1	152.9	86.3	116.9	147.6
		76	TC	–	291.7	291.7	–	279.2	279.2	–	265.7	265.7	–	251.3	251.3	–	235.8	235.8
			SHC	–	110.7	143.7	–	106.5	139.5	–	102	134.7	–	97.2	129.7	–	92.1	124.3
7000 CFM	EAT (wb)	58	TC	225.8	225.8	255.3	217.8	217.8	246.3	209.1	209.1	236.5	199.6	199.6	225.7	189.2	189.2	214.0
			SHC	196.2	225.8	255.3	189.3	217.8	246.3	181.7	209.1	236.5	173.4	199.6	225.7	164.4	189.2	214.0
		62	TC	233.9	233.9	248.8	223.8	223.8	243.8	213.1	213.1	238.2	201.4	201.4	231.8	190.0	190.0	221.5
			SHC	179.4	214.1	248.8	174.6	209.2	243.8	169.4	203.8	238.2	163.7	197.8	231.8	155.9	188.7	221.5
		67	TC	255.7	255.7	255.7	244.6	244.6	244.6	232.6	232.6	232.6	219.6	219.6	219.6	205.7	205.7	205.7
			SHC	144.7	179.7	214.8	140.2	175.2	210.2	135.4	170.4	205.4	130.3	165.2	200.2	124.9	159.8	194.7
		72	TC	279.4	279.4	279.4	267.3	267.3	267.3	254.1	254.1	254.1	240.1	240.1	240.1	224.9	224.9	224.9
			SHC	108.7	144.1	179.6	104.3	139.7	175.1	99.6	135	170.3	94.7	129.9	165.1	89.5	124.6	159.7
		76	TC	–	299.4	299.4	–	286.2	286.2	–	272.1	272.1	–	256.9	256.9	–	240.7	240.7
			SHC	–	115.3	152.9	–	110.9	148.2	–	106.3	143.3	–	101.3	138.0	–	96.1	132.6
8000 CFM	EAT (wb)	58	TC	235.3	235.3	266.2	226.8	226.8	256.5	217.5	217.5	246	207.4	207.4	234.5	196.3	196.3	222.0
			SHC	204.5	235.3	266.2	197.1	226.8	256.5	189	217.5	246	180.2	207.4	234.5	170.6	196.3	222.0
		62	TC	239.7	239.7	268.1	229.4	229.4	262.0	219	219	253.3	208.3	208.3	241.9	196.7	196.7	231.0
			SHC	190.7	229.4	268.1	185.4	223.7	262.0	178.6	215.9	253.3	170.4	206.2	241.9	162.3	196.7	231.0
		67	TC	261.3	261.3	261.3	249.6	249.6	249.6	237.1	237.1	237.1	223.6	223.6	223.6	209.2	209.2	210.6
			SHC	152.3	191.8	231.2	147.7	187.1	226.6	142.9	182.2	221.6	137.7	177.0	216.3	132.2	171.4	210.6
		72	TC	285.3	285.3	285.3	272.5	272.5	272.5	258.9	258.9	258.9	244.2	244.2	244.2	228.6	228.6	228.6
			SHC	111.9	151.7	191.5	107.5	147.2	186.9	102.7	142.4	182	97.7	137.2	176.7	92.4	131.8	171.2
		76	TC	–	305.4	305.4	–	291.6	291.6	–	276.8	276.8	–	261.2	261.2	–	244.4	244.4
			SHC	–	119.4	161.0	–	114.9	156.2	–	110.1	151.2	–	105.1	146.0	–	99.8	140.4
9000 CFM	EAT (wb)	58	TC	243.5	243.5	275.4	234.5	234.5	265.2	224.6	224.6	254	213.9	213.9	241.9	202.3	202.3	228.8
			SHC	211.6	243.5	275.4	203.8	234.5	265.2	195.2	224.6	254	185.9	213.9	241.9	175.8	202.3	228.8
		62	TC	245.4	245.4	282.9	235.4	235.4	274.6	225	225	264.3	214.4	214.4	251.7	202.5	202.5	237.8
			SHC	199.7	241.3	282.9	193.2	233.9	274.6	185.6	224.9	264.3	176.8	214.3	251.7	167.1	202.5	237.8
		67	TC	265.6	265.6	265.6	253.6	253.6	253.6	240.7	240.7	240.7	226.8	226.8	231.8	212.0	212.0	225.8
			SHC	159.6	203.3	247.1	154.9	198.6	242.3	150	193.6	237.3	144.7	188.3	231.8	139.0	182.4	225.8
		72	TC	289.9	289.9	289.9	276.7	276.7	276.7	262.6	262.6	262.6	247.5	247.5	247.5	231.4	231.4	231.4
			SHC	114.9	159.0	203.0	110.4	154.4	198.3	105.6	149.5	193.3	100.5	144.2	188.0	95.2	138.7	182.3
		76	TC	–	310.1	310.1	–	295.8	295.8	–	280.6	280.6	–	264.4	264.4	–	247.3	247.3
			SHC	–	123.2	168.9	–	118.6	164.1	–	113.8	159	–	108.7	153.6	–	103.4	147.9
10,000 CFM	EAT (wb)	58	TC	250.4	250.4	283.2	240.9	240.9	272.5	230.7	230.7	260.9	219.5	219.5	248.2	207.3	207.3	234.5
			SHC	217.7	250.4	283.2	209.4	240.9	272.5	200.5	230.7	260.9	190.7	219.5	248.2	180.2	207.3	234.5
		62	TC	250.8	250.8	294.6	241.1	241.1	283.3	231.1	231.1	271.4	219.6	219.6	258.0	207.5	207.5	243.7
			SHC	207.0	250.8	294.6	199.0	241.1	283.3	190.7	231.1	271.4	181.2	219.6	258.0	171.2	207.5	243.7
		67	TC	269.2	269.2	269.2	256.8	256.8	257.6	243.5	243.5	252.3	229.4	229.4	246.4	214.3	214.3	240.0
			SHC	166.6	214.5	262.5	161.9	209.7	257.6	156.8	204.5	252.3	151.3	198.9	246.4	145.5	192.8	240.0
		72	TC	293.7	293.7	293.7	280.1	280.1	280.1	265.6	265.6	265.6	250.2	250.2	250.2	233.7	233.7	233.7
			SHC	117.8	166.0	214.2	113.2	161.3	209.3	108.3	156.3	204.3	103.2	151.0	198.8	97.8	145.4	193.1
		76	TC	–	313.9	313.9	–	299.3	299.3	–	283.7	283.7	–	267.1	267.1	–	249.6	249.6
			SHC	–	126.8	176.5	–	122.2	171.6	–	117.3	166.5	–	112.1	161.0	–	106.7	155.1

LEGEND:

- Do not operate
- Cfm – Cubic feet per minute (supply air)
- EAT(db) – Entering air temperature (dry bulb)
- EAT(wb) – Entering air temperature (wet bulb)
- SHC – Sensible heat capacity
- TC – Total capacity

20 TONS – UNIT WITH HOT GAS REHEAT IN SUBCOOLING MODE										
Temp (F) Air Ent Condenser (Edb)		AIR ENTERING EVAPORATOR – CFM								
		6,000			8,000			10,000		
		Air Entering Evaporator --- Ewb (F)								
		72	67	62	72	67	62	72	67	62
75	TC	281.6	256.5	231.3	293.1	267.0	240.9	302.3	275.4	248.6
	SHC	114.7	141.0	167.4	140.6	166.6	192.6	161.6	187.3	212.9
	kW	13.52	13.25	12.95	13.82	13.46	13.21	13.97	13.60	13.31
85	TC	261.3	236.9	212.4	272.1	247.7	221.3	280.7	254.6	228.5
	SHC	90.9	123.5	156.1	118.8	151.1	183.3	141.4	173.4	205.4
	kW	14.95	14.68	14.48	15.25	14.89	14.64	15.40	15.03	14.74
95	TC	241.1	217.2	193.4	251.1	226.4	201.7	259.2	233.8	208.4
	SHC	67.2	106.0	144.8	97.1	120.1	174.1	121.2	159.5	197.8
	kW	16.52	16.25	15.95	16.82	16.46	16.21	16.97	16.60	16.31
105	TC	220.8	197.5	174.4	230.2	206.2	182.2	237.7	213.0	188.4
	SHC	43.4	88.4	133.5	75.3	120.1	164.9	101.0	145.7	178.9
	kW	18.09	17.82	17.52	18.39	18.03	17.78	18.54	18.17	17.88
115	TC	200.5	178.0	155.5	209.2	185.9	162.6	216.2	192.2	168.7
	SHC	19.7	70.9	122.2	53.5	104.6	155.7	80.9	131.8	161.2
	kW	19.65	19.38	19.08	19.95	19.59	19.34	20.10	19.73	19.44
125	TC	180.2	158.4	136.5	188.2	165.6	143.0	194.7	171.4	148.2
	SHC	-4.1	53.4	110.8	31.7	89.1	142.2	60.7	118.0	145.1
	kW	20.59	20.32	20.02	20.89	20.53	20.28	21.04	20.67	20.38

20 TONS – UNIT WITH HOT GAS REHEAT IN HOT GAS REHEAT MODE										
Temp (F) Air Ent Condenser (Edb)		AIR ENTERING EVAPORATOR – Ewb (F)								
		75 Dry Bulb			75 Dry Bulb			75 Dry Bulb		
		62.5 Wet Bulb			64 Wet Bulb			65.3 Wet Bulb		
		(50% Relative)			(56% Relative)			(60% Relative)		
		Air Entering Evaporator – Cfm								
		6,000	8,000	10,000	6,000	8,000	10,000	6,000	8,000	10,000
80	TC	115.20	123.30	130.60	120.40	129.30	138.20	122.80	135.00	143.70
	SHC	40.80	58.30	76.10	32.30	45.50	60.40	20.10	34.30	48.00
	kW	13.24	13.32	13.39	13.43	13.57	13.65	13.49	13.68	13.74
75	TC	119.80	128.60	135.90	125.50	135.30	143.20	128.00	139.50	148.40
	SHC	45.60	62.80	82.10	37.00	49.80	65.20	24.30	38.70	52.60
	kW	13.05	13.10	13.17	13.21	13.35	13.43	13.27	13.46	13.52
70	TC	122.50	133.10	140.20	129.80	140.70	147.60	132.40	144.40	153.20
	SHC	49.80	76.00	86.10	41.10	54.30	69.20	28.80	41.40	56.80
	kW	12.80	12.87	12.94	12.98	13.12	13.20	13.04	13.23	13.29
60	TC	133.80	142.50	149.60	139.30	150.40	157.40	141.50	154.20	163.00
	SHC	58.60	76.00	95.00	50.20	63.50	78.10	37.80	52.10	65.90
	kW	12.34	12.42	12.49	12.53	12.67	12.75	12.59	12.78	12.84
50	TC	143.50	151.80	159.30	149.00	160.00	167.00	151.30	163.60	172.50
	SHC	67.70	84.80	103.80	59.10	72.40	87.00	46.70	61.00	74.90
	kW	11.88	11.95	12.03	12.07	12.21	12.29	12.13	12.32	12.38
40	TC	153.20	161.30	168.70	158.60	169.20	176.60	160.80	173.10	182.00
	SHC	76.50	93.60	111.60	68.00	81.50	95.80	55.80	69.80	84.00
	kW	11.42	11.49	11.56	11.60	11.74	11.82	11.66	11.85	11.91

LEGEND

- Edb** – Entering Dry–Bulb
- Ewb** – Entering Wet–Bulb
- kW** – Compressor Motor Power Input
- ldb** – Leaving Dry–Bulb
- lwb** – Leaving Wet–Bulb
- SHC** – Sensible Heat Capacity (1000 Btuh) Gross
- TC** – Total Capacity (1000 Btuh) Gross

NOTES:

.Direct interpolation is permissible. Do not extrapolate.
 .The following formulas may be used:

$$t_{ldb} = t_{edb} - \frac{\text{sensible capacity (Btuh)}}{1.10 \times \text{cfm}}$$

t_{lwb} = Wet–bulb temperature corresponding to enthalpy of air leaving evaporator coil (h_{lwb})

$$h_{lwb} = h_{ewb} - \frac{\text{total capacity (Btuh)}}{4.5 \times \text{cfm}}$$

Where: h_{ewb} = Enthalpy of air entering evaporator coil

Table 14 – COOLING CAPACITIES 25 TONS (2 Stage Cooling)

RGH300/303				AMBIENT TEMPERATURE														
				85			95			105			115			125		
				EA (dB)			EA (dB)			EA (dB)			EA (dB)			EA (dB)		
				75	80	85	75	80	85	75	80	85	75	80	85	75	80	85
7,500 CFM	EAT (wb)	58	TC	264.4	264.4	298.9	254.6	254.6	287.9	244.1	244.1	276.0	232.7	232.7	263.1	220.3	220.3	249.1
			SHC	229.9	264.4	298.9	221.4	254.6	287.9	212.2	244.1	276.0	202.3	232.7	263.1	191.5	220.3	249.1
		62	TC	278.7	278.7	282.4	266.3	266.3	276.4	252.8	252.8	269.8	238.5	238.5	262.4	223.9	223.9	251.3
			SHC	206.8	244.6	282.4	200.9	238.7	276.4	194.6	232.2	269.8	187.7	225.0	262.4	178.7	215.0	251.3
		67	TC	305.3	305.3	305.3	291.9	291.9	291.9	277.3	277.3	277.3	261.5	261.5	261.5	244.5	244.5	244.5
			SHC	169.0	207.0	245.0	163.4	201.4	239.4	157.4	195.3	233.3	151.0	188.9	226.8	144.2	182.1	219.9
		72	TC	334.0	334.0	334.0	319.4	319.4	319.4	303.6	303.6	303.6	286.5	286.5	286.5	268.1	268.1	268.1
			SHC	129.9	168.5	207.1	124.5	163.0	201.5	118.7	157.1	195.5	112.5	150.8	189.2	106.0	144.2	182.3
		76	TC	–	358.2	358.2	–	342.4	342.4	–	325.4	325.4	–	307.1	307.1	–	287.4	287.4
			SHC	–	137.0	178.2	–	131.7	172.9	–	126.0	166.9	–	119.9	160.4	–	113.4	153.4
8,750 CFM	EAT (wb)	58	TC	278.2	278.2	314.5	267.8	267.8	302.8	256.5	256.5	289.9	244.2	244.2	276.1	230.8	230.8	261.0
			SHC	241.9	278.2	314.5	232.8	267.8	302.8	223.0	256.5	289.9	212.3	244.2	276.1	200.7	230.8	261.0
		62	TC	287.2	287.2	308.3	274.3	274.3	301.5	260.8	260.8	291.7	247.0	247.0	280.9	232.0	232.0	269.1
			SHC	222.1	265.2	308.3	215.7	258.6	301.5	207.7	249.7	291.7	199.0	240.0	280.9	189.7	229.4	269.1
		67	TC	314.0	314.0	314.0	299.8	299.8	299.8	284.4	284.4	284.4	267.8	267.8	267.8	250.0	250.0	250.0
			SHC	179.1	222.7	266.4	173.3	216.9	260.6	167.2	210.8	254.3	160.7	204.2	247.7	153.7	197.2	240.6
		72	TC	343.0	343.0	343.0	327.7	327.7	327.7	311.1	311.1	311.1	293.1	293.1	293.1	273.8	273.8	273.8
			SHC	134.3	178.5	222.6	128.8	172.9	216.9	122.9	166.9	210.8	116.6	160.4	204.3	109.9	153.6	197.3
		76	TC	–	367.3	367.3	–	350.8	350.8	–	333.0	333.0	–	313.8	313.8	–	293.2	293.2
			SHC	–	142.6	189.4	–	137.1	183.5	–	131.2	177.3	–	125.0	170.7	–	118.4	163.7
10,000 CFM	EAT (wb)	58	TC	289.7	289.7	327.5	278.7	278.7	315.0	266.6	266.6	301.4	253.6	253.6	286.7	239.4	239.4	270.7
			SHC	251.9	289.7	327.5	242.3	278.7	315.0	231.8	266.6	301.4	220.5	253.6	286.7	208.2	239.4	270.7
		62	TC	294.6	294.6	329.6	282.2	282.2	319.7	268.7	268.7	309.1	254.1	254.1	298.4	239.7	239.7	281.4
			SHC	234.7	282.1	329.6	226.8	273.3	319.7	218.4	263.7	309.1	209.7	254.1	298.4	197.9	239.7	281.4
		67	TC	320.6	320.6	320.6	305.9	305.9	305.9	289.9	289.9	289.9	272.7	272.7	272.7	254.3	254.3	260.3
			SHC	188.6	237.7	286.8	182.7	231.8	280.9	176.5	225.5	274.5	169.8	218.8	267.7	162.8	211.5	260.3
		72	TC	350.0	350.0	350.0	334.0	334.0	334.0	316.8	316.8	316.8	298.2	298.2	298.2	278.3	278.3	278.3
			SHC	138.4	187.9	237.5	132.8	182.2	231.7	126.8	176.1	225.5	120.4	169.6	218.8	113.6	162.6	211.7
		76	TC	–	374.4	374.4	–	357.3	357.3	–	338.7	338.7	–	318.9	318.9	–	297.5	297.5
			SHC	–	147.7	199.5	–	142.1	193.7	–	136.1	187.4	–	129.7	180.6	–	123.0	173.5
11,250 CFM	EAT (wb)	58	TC	299.4	299.4	338.4	287.8	287.8	325.4	275.2	275.2	311.1	261.4	261.4	295.6	246.6	246.6	278.8
			SHC	260.3	299.4	338.4	250.2	287.8	325.4	239.2	275.2	311.1	227.3	261.4	295.6	214.4	246.6	278.8
		62	TC	302.2	302.2	346.0	289.3	289.3	335.7	275.5	275.5	323.5	262.1	262.1	307.7	246.8	246.8	289.8
			SHC	244.8	295.4	346.0	236.7	286.2	335.7	227.5	275.5	323.5	216.4	262.1	307.7	203.8	246.8	289.8
		67	TC	325.9	325.9	325.9	310.7	310.7	310.7	294.2	294.2	294.2	276.6	276.6	286.7	257.7	257.7	278.9
			SHC	197.6	252.1	306.5	191.7	246.1	300.4	185.3	239.6	293.9	178.5	232.6	286.7	171.2	225.1	278.9
		72	TC	355.5	355.5	355.5	339.1	339.1	339.1	321.3	321.3	321.3	302.2	302.2	302.2	281.8	281.8	281.8
			SHC	142.1	197.0	251.8	136.4	191.2	245.9	130.4	185.0	239.6	123.9	178.3	232.8	117.1	171.3	225.5
		76	TC	–	380.0	380.0	–	362.4	362.4	–	343.3	343.3	–	322.8	322.8	–	300.9	300.9
			SHC	–	152.4	209.4	–	146.8	203.4	–	140.7	197.0	–	134.2	190.2	–	127.3	182.8
12,500 CFM	EAT (wb)	58	TC	307.7	307.7	347.9	295.7	295.7	334.2	282.5	282.5	319.3	268.2	268.2	303.2	252.7	252.7	285.7
			SHC	267.6	307.7	347.9	257.1	295.7	334.2	245.6	282.5	319.3	233.2	268.2	303.2	219.7	252.7	285.7
		62	TC	308.4	308.4	362.2	295.9	295.9	347.4	283.1	283.1	332.4	268.4	268.4	315.2	252.8	252.8	296.9
			SHC	254.6	308.4	362.2	244.4	295.9	347.4	233.8	283.1	332.4	221.7	268.4	315.2	208.8	252.8	296.9
		67	TC	330.2	330.2	330.2	314.6	314.6	319.2	297.8	297.8	312.3	279.8	279.8	304.7	260.6	260.6	295.9
			SHC	206.3	265.9	325.5	200.3	259.7	319.2	193.8	253.1	312.3	186.7	245.7	304.7	179.0	237.4	295.9
		72	TC	360.1	360.1	360.1	343.2	343.2	343.2	325.0	325.0	325.0	305.4	305.4	305.4	284.6	284.6	284.6
			SHC	145.7	205.7	265.7	139.9	199.8	259.7	133.8	193.5	253.3	127.3	186.8	246.3	120.4	179.7	238.9
		76	TC	–	384.6	384.6	–	366.5	366.5	–	346.9	346.9	–	325.9	325.9	–	303.5	303.5
			SHC	–	157.0	218.9	–	151.2	212.9	–	145.1	206.3	–	138.5	199.3	–	131.5	191.7

LEGEND:

- Do not operate
- Cfm – Cubic feet per minute (supply air)
- EAT(db) – Entering air temperature (dry bulb)
- EAT(wb) – Entering air temperature (wet bulb)
- SHC – Sensible heat capacity
- TC – Total capacity

25 TONS – UNIT WITH HOT GAS REHEAT IN SUBCOOLING MODE										
Temp (F) Air Ent Condenser (Edb)		AIR ENTERING EVAPORATOR – CFM								
		7,500			10,000			12,500		
		Air Entering Evaporator --- Ewb (F)								
		72	67	62	72	67	62	72	67	62
75	TC	351.3	319.5	287.8	370.4	337.3	304.1	385.8	351.5	317.2
	SHC	166.5	199.4	232.3	191.2	245.6	258.5	211.4	245.6	279.9
	kW	16.75	16.55	15.20	17.30	16.75	15.85	17.80	17.50	16.50
85	TC	327.5	296.4	265.3	346.1	313.6	281.2	361.1	327.5	294.0
	SHC	137.4	178.2	219.0	162.6	204.5	246.4	183.3	226.0	268.7
	kW	18.65	18.45	17.25	19.20	18.65	17.80	19.45	19.15	18.15
95	TC	303.7	273.3	242.9	321.8	290.0	258.3	336.4	303.5	270.7
	SHC	108.2	157.0	205.8	134.0	184.1	234.3	155.1	206.4	257.6
	kW	20.60	20.40	19.34	21.15	20.60	19.95	21.60	21.30	20.30
105	TC	279.9	250.2	220.4	297.5	266.4	235.3	311.7	279.5	247.4
	SHC	79.0	135.8	192.5	105.4	163.8	222.2	127.1	186.7	246.4
	kW	22.85	22.65	21.45	23.40	22.85	22.05	23.70	23.40	22.40
115	TC	256.2	227.1	198.0	273.2	242.8	212.4	287.0	255.5	224.1
	SHC	49.9	114.5	179.2	76.8	143.4	210.1	98.9	167.1	223.8
	kW	25.05	24.85	23.65	25.60	25.05	24.25	25.90	25.60	24.60
125	TC	232.4	203.9	175.5	248.9	219.2	189.5	262.3	231.5	200.8
	SHC	20.7	93.3	166.0	48.2	123.1	188.9	70.8	147.4	200.8
	kW	27.25	27.05	25.80	27.80	27.25	26.50	28.15	27.85	26.85

25 TONS – UNIT WITH HOT GAS REHEAT IN HOT GAS REHEAT MODE										
Temp (F) Air Ent Condenser (Edb)		AIR ENTERING EVAPORATOR – Ewb (F)								
		75 Dry Bulb			75 Dry Bulb			75 Dry Bulb		
		62.5 Wet Bulb			64 Wet Bulb			65.3 Wet Bulb		
		(50% Relative)			(56% Relative)			(60% Relative)		
		Air Entering Evaporator – Cfm								
7,500	10,000	12,500	7,500	10,000	12,500	7,500	10,000	12,500		
80	TC	124.40	133.90	139.00	132.00	142.10	145.10	135.60	149.10	151.50
	SHC	37.60	60.70	82.20	27.80	45.40	65.80	17.50	34.20	50.10
	kW	15.83	15.90	16.00	15.97	16.13	16.16	16.11	16.31	16.38
75	TC	129.00	138.50	144.60	136.60	147.60	150.10	140.60	154.00	156.30
	SHC	47.10	70.60	92.10	37.30	55.30	75.70	27.00	43.70	60.00
	kW	15.77	15.83	15.94	15.91	16.07	16.10	16.05	16.25	16.32
70	TC	133.60	143.10	149.20	141.20	152.30	154.80	145.30	158.80	161.10
	SHC	57.30	80.70	102.20	47.50	65.40	85.80	37.20	53.90	70.10
	kW	15.68	15.75	15.86	15.83	16.00	16.04	15.88	16.08	16.15
60	TC	142.80	158.40	158.40	150.40	161.40	163.90	153.90	167.40	169.70
	SHC	76.50	121.40	121.40	66.70	84.60	105.00	56.40	73.10	89.30
	kW	15.54	15.60	15.71	15.68	15.84	15.87	15.82	16.02	16.09
50	TC	151.80	161.30	167.40	159.40	170.50	173.20	162.80	176.20	178.80
	SHC	94.10	117.50	139.00	84.30	102.20	122.60	74.00	90.70	106.90
	kW	15.40	15.47	15.58	15.54	15.68	15.71	15.66	15.86	15.93
40	TC	161.20	170.70	176.80	168.80	179.80	182.50	172.20	185.70	188.20
	SHC	114.10	137.60	159.10	104.30	122.30	142.70	94.00	110.70	127.00
	kW	15.24	15.31	15.42	15.39	15.55	15.58	15.53	15.73	15.80

LEGEND

- Edb** – Entering Dry–Bulb
- Ewb** – Entering Wet–Bulb
- kW** – Compressor Motor Power Input
- ldb** – Leaving Dry–Bulb
- lwb** – Leaving Wet–Bulb
- SHC** – Sensible Heat Capacity (1000 Btuh) Gross
- TC** – Total Capacity (1000 Btuh) Gross

NOTES:

.Direct interpolation is permissible. Do not extrapolate.
 .The following formulas may be used:

$$t_{ldb} = t_{edb} - \frac{\text{sensible capacity (Btuh)}}{1.10 \times \text{cfm}}$$

t_{lwb} = Wet–bulb temperature corresponding to enthalpy of air leaving evaporator coil (h_{lwb})

$$h_{lwb} = h_{ewb} - \frac{\text{total capacity (Btuh)}}{4.5 \times \text{cfm}}$$

Where: h_{ewb} = Enthalpy of air entering evaporator coil

Table 16 – STATIC PRESSURE ADDERS (Factory Options and/or Accessories)

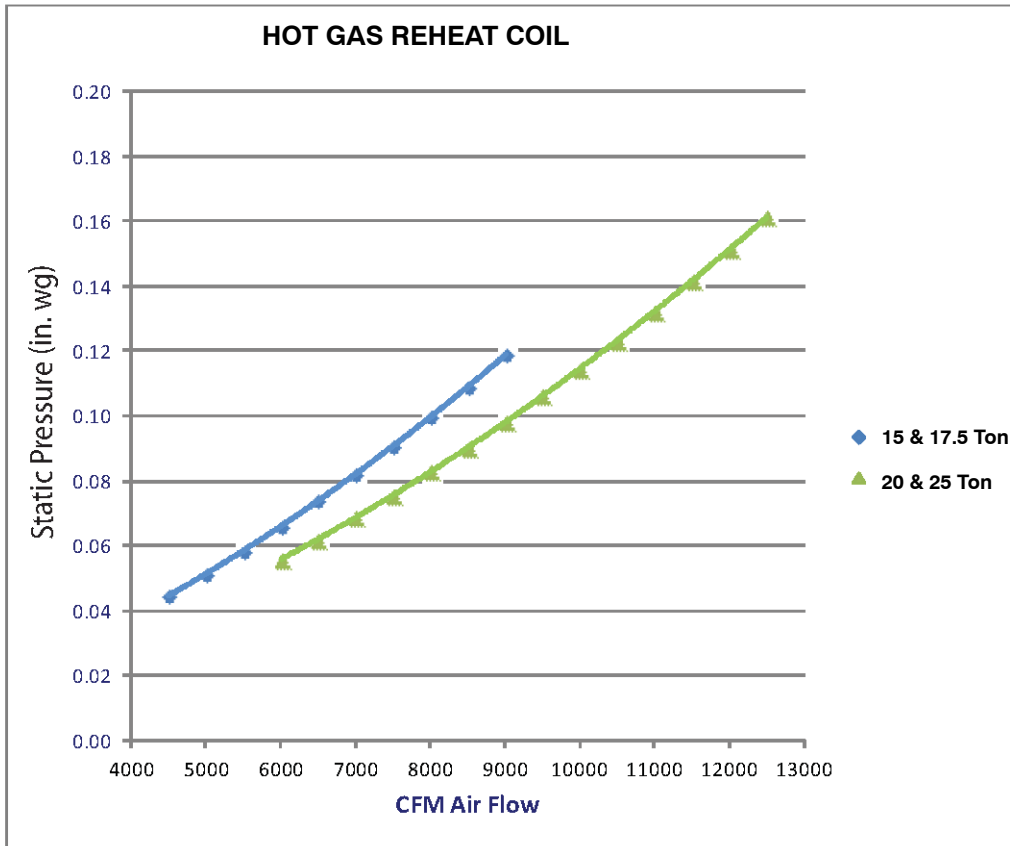

C11174

Economizer – Vertical and Horizontal Duct Configuration

Model Sizes 181 – 303								
CFM	4500	5000	5500	6000	6500	7000	7500	8000
Vertical & Horizontal	0.047	0.052	0.057	0.062	0.067	0.072	0.077	0.082

Model Sizes 181 – 303									
CFM	8500	9000	9500	10000	10500	11000	11500	12000	12500
Vertical & Horizontal	0.088	0.093	0.098	0.103	0.109	0.114	0.119	0.125	0.131

General fan performance notes:

1. Interpolation is permissible. Do not extrapolate.
2. External static pressure is the static pressure difference between the return duct and the supply duct plus the static pressure caused by any FIOPs or accessories.
3. Tabular data accounts for pressure loss due to clean filters, high gas heat, unit casing, and wet coils. Factory options and accessories may add static pressure losses, as shown in Table 16.
4. The Fan Performance tables offer motor/drive recommendations. In cases when two motor/drive combinations would work, the lower horsepower option is recommended.
5. For information on the electrical properties of motors, please see the Electrical information section of this book.
6. For more information on the performance limits of motors, see the application data section of this book.

FAN PERFORMANCE

Table 17 – RGH181, 15 TON VERTICAL SUPPLY / RETURN

CFM	Available External Static Pressure (in. wg)									
	0.2		0.4		0.6		0.8		1.0	
	RPM	BHP	RPM	BHP	RPM	BHP	RPM	BHP	RPM	BHP
4500	490	0.76	575	1.07	653	1.41	724	1.79	791	2.19
4900	517	0.92	597	1.24	671	1.60	740	1.99	804	2.41
5250	541	1.08	618	1.42	688	1.79	754	2.19	817	2.62
5600	566	1.26	639	1.61	707	2.00	770	2.42	831	2.86
6000	595	1.49	664	1.86	729	2.27	790	2.70	848	3.15
6400	624	1.75	690	2.14	751	2.56	810	3.01	866	3.48
6750	650	2.00	713	2.41	772	2.84	829	3.30	883	3.79
7100	676	2.27	736	2.70	793	3.15	848	3.63	901	4.13
7500	706	2.62	763	3.06	819	3.54	871	4.03	922	4.55

CFM	Available External Static Pressure (in. wg)									
	1.2		1.4		1.6		1.8		2.0	
	RPM	BHP	RPM	BHP	RPM	BHP	RPM	BHP	RPM	BHP
4500	854	2.63	913	3.09	970	3.57	1024	4.09	1077	4.62
4900	865	2.86	923	3.33	978	3.83	1031	4.35	1082	4.89
5250	876	3.08	932	3.56	986	4.07	1038	4.60	-----	-----
5600	888	3.33	943	3.82	995	4.34	1046	4.88	-----	-----
6000	903	3.64	956	4.14	1008	4.67	-----	-----	-----	-----
6400	920	3.98	971	4.50	-----	-----	-----	-----	-----	-----
6750	935	4.30	986	4.83	-----	-----	-----	-----	-----	-----
7100	952	4.65	-----	-----	-----	-----	-----	-----	-----	-----
7500	-----	-----	-----	-----	-----	-----	-----	-----	-----	-----

Std Static Motor and Drive – 514–680 RPM, Max BHP 2.2

Medium Static Motor and Drive – 679–863 RPM, Max BHP 3.3

High Static Motor and Drive – 826–1009 RPM, Max BHP 4.9

----- Outside operating range

Boldface – Field-supplied Drive

Table 18 – RGH210, 17.5 TON VERTICAL SUPPLY / RETURN

CFM	Available External Static Pressure (in. wg)									
	0.2		0.4		0.6		0.8		1.0	
	RPM	BHP	RPM	BHP	RPM	BHP	RPM	BHP	RPM	BHP
5250	541	1.08	618	1.42	688	1.79	754	2.19	817	2.62
5700	573	1.31	645	1.67	712	2.06	775	2.48	835	2.93
6100	602	1.55	670	1.93	734	2.34	795	2.77	852	3.23
6500	631	1.81	696	2.21	757	2.64	815	3.09	871	3.57
7000	668	2.19	729	2.61	787	3.06	843	3.53	896	4.03
7500	706	2.62	763	3.06	819	3.54	871	4.03	922	4.55
7900	736	3.00	791	3.47	844	3.96	895	4.47	944	5.00
8300	767	3.42	819	3.90	870	4.41	919	4.94	967	5.49
8750	801	3.94	852	4.44	900	4.97	948	5.52	993	6.09

CFM	Available External Static Pressure (in. wg)									
	1.2		1.4		1.6		1.8		2.0	
	RPM	BHP	RPM	BHP	RPM	BHP	RPM	BHP	RPM	BHP
5250	876	3.08	932	3.56	986	4.07	1038	4.60	1088	5.15
5700	892	3.40	946	3.90	998	4.42	1049	4.96	1097	5.52
6100	907	3.72	960	4.23	1011	4.76	1060	5.31	1107	5.89
6500	924	4.07	975	4.59	1025	5.13	1072	5.70	1119	6.28
7000	947	4.55	996	5.09	1044	5.65	1090	6.23	-----	-----
7500	971	5.08	1019	5.64	1064	6.22	-----	-----	-----	-----
7900	992	5.55	1038	6.13	-----	-----	-----	-----	-----	-----
8300	1013	6.06	-----	-----	-----	-----	-----	-----	-----	-----
8750	-----	-----	-----	-----	-----	-----	-----	-----	-----	-----

Std Static Motor and Drive – 622–822 RPM, Max BHP 3.3

Medium Static Motor and Drive – 713–879 RPM, Max BHP 4.9

High Static Motor and Drive – 882–1078 RPM, Max BHP 6.5

----- Outside operating range

Boldface – Field-supplied Drive

FAN PERFORMANCE (cont.)

Table 19 – RGH240, 20 TON VERTICAL SUPPLY / RETURN

CFM	Available External Static Pressure (in. wg)									
	0.2		0.4		0.6		0.8		1.0	
	RPM	BHP	RPM	BHP	RPM	BHP	RPM	BHP	RPM	BHP
6000	605	1.48	674	1.77	738	2.08	798	2.41	854	2.74
6500	644	1.82	709	2.14	770	2.47	827	2.81	881	3.17
7000	683	2.22	744	2.56	802	2.91	857	3.28	908	3.65
7500	722	2.68	781	3.04	836	3.41	888	3.80	938	4.19
8000	762	3.20	818	3.58	870	3.97	920	4.38	968	4.79
8500	803	3.78	855	4.19	905	4.60	953	5.02	999	5.46
9000	843	4.43	893	4.86	941	5.30	987	5.74	1032	6.19
9500	884	5.15	932	5.61	978	6.06	1022	6.53	1065	7.01
10000	925	5.95	970	6.43	1015	6.91	1057	7.40	1098	7.89

CFM	Available External Static Pressure (in. wg)									
	1.2		1.4		1.6		1.8		2.0	
	RPM	BHP	RPM	BHP	RPM	BHP	RPM	BHP	RPM	BHP
6000	907	3.10	958	3.46	1006	3.84	1052	4.23	1097	4.63
6500	932	3.54	981	3.92	1027	4.31	1073	4.72	1116	5.14
7000	958	4.04	1005	4.43	1051	4.84	1094	5.27	1137	5.70
7500	985	4.59	1031	5.01	1075	5.44	1118	5.87	1159	6.32
8000	1014	5.21	1058	5.65	1101	6.09	1142	6.55	-----	-----
8500	1044	5.90	1087	6.35	1128	6.82	1168	7.29	-----	-----
9000	1075	6.66	1116	7.13	1156	7.61	-----	-----	-----	-----
9500	1106	7.49	1146	7.98	-----	-----	-----	-----	-----	-----
10000	1139	8.40	-----	-----	-----	-----	-----	-----	-----	-----

Std Static Motor and Drive – 690–863 RPM, Max BHP 4.9

Medium Static Motor and Drive – 835–1021 RPM, Max BHP 6.5

High Static Motor and Drive – 941–1176 RPM, Max BHP 8.7

----- Outside operating range

Boldface – Field-supplied Drive

Table 20 – RGH300, 25 TON VERTICAL SUPPLY / RETURN

CFM	Available External Static Pressure (in. wg)									
	0.2		0.4		0.6		0.8		1.0	
	RPM	BHP	RPM	BHP	RPM	BHP	RPM	BHP	RPM	BHP
7500	713	2.25	778	2.61	838	2.97	894	3.36	946	3.76
8000	752	2.68	814	3.06	871	3.44	925	3.85	976	4.26
8500	791	3.17	850	3.56	905	3.97	957	4.39	1006	4.83
9000	831	3.71	887	4.12	939	4.55	989	4.99	1037	5.45
9500	870	4.31	924	4.75	974	5.19	1023	5.66	1069	6.13
10000	910	4.83	961	5.43	1010	5.90	1057	6.38	1102	6.87
10500	950	5.70	999	6.18	1046	6.67	1091	7.17	1135	7.69
11000	990	6.50	1037	7.01	1083	7.52	1126	8.04	1168	8.57
11500	1030	7.38	1076	7.90	1119	8.43	-----	-----	-----	-----
12000	1070	8.33	-----	-----	-----	-----	-----	-----	-----	-----
12500	-----	-----	-----	-----	-----	-----	-----	-----	-----	-----

CFM	Available External Static Pressure (in. wg)									
	1.2		1.4		1.6		1.8		1.0	
	RPM	BHP	RPM	BHP	RPM	BHP	RPM	BHP	RPM	BHP
7500	996	4.17	1044	4.60	1089	5.05	1133	5.51	1175	5.98
8000	1024	4.70	1071	5.14	1115	5.60	1158	6.07	-----	-----
8500	1053	5.27	1098	5.74	1141	6.21	-----	-----	-----	-----
9000	1083	5.91	1127	6.39	1169	6.88	-----	-----	-----	-----
9500	1113	6.61	1156	7.11	-----	-----	-----	-----	-----	-----
10000	1145	7.38	-----	-----	-----	-----	-----	-----	-----	-----
10500	-----	-----	-----	-----	-----	-----	-----	-----	-----	-----
11000	-----	-----	-----	-----	-----	-----	-----	-----	-----	-----
11500	-----	-----	-----	-----	-----	-----	-----	-----	-----	-----
12000	-----	-----	-----	-----	-----	-----	-----	-----	-----	-----
12500	-----	-----	-----	-----	-----	-----	-----	-----	-----	-----

Std Static Motor and Drive – 717–911 RPM, Max BHP 4.9

Medium Static Motor and Drive – 913–1116 RPM, Max BHP 6.5

High Static Motor and Drive – 941–1176 RPM, Max BHP 8.7

----- Outside operating range

Boldface – Field-supplied Drive

FAN PERFORMANCE (cont.)

Table 21 – RGH183, 15 TON HORIZONTAL SUPPLY / RETURN

CFM	Available External Static Pressure (in. wg)									
	0.2		0.4		0.6		0.8		1.0	
	RPM	BHP	RPM	BHP	RPM	BHP	RPM	BHP	RPM	BHP
4500	523	1.13	593	1.56	656	2.03	713	2.55	766	3.10
4900	557	1.38	623	1.84	683	2.33	738	2.87	790	3.44
5250	587	1.62	650	2.11	708	2.63	761	3.18	811	3.77
5600	617	1.90	678	2.41	733	2.95	785	3.53	833	4.14
6000	652	2.25	710	2.80	763	3.37	813	3.97	860	4.60
6400	688	2.65	743	3.24	794	3.84	841	4.46	-----	-----
6750	719	3.04	772	3.66	821	4.29	-----	-----	-----	-----
7100	750	3.47	802	4.12	849	4.78	-----	-----	-----	-----
7500	786	4.01	836	4.70	-----	-----	-----	-----	-----	-----

CFM	Available External Static Pressure (in. wg)									
	1.2		1.4		1.6		1.8		2.0	
	RPM	BHP	RPM	BHP	RPM	BHP	RPM	BHP	RPM	BHP
4500	814	3.68	859	4.27	901	4.88	-----	-----	-----	-----
4900	837	4.05	882	4.67	-----	-----	-----	-----	-----	-----
5250	858	4.40	-----	-----	-----	-----	-----	-----	-----	-----
5600	879	4.78	-----	-----	-----	-----	-----	-----	-----	-----
6000	-----	-----	-----	-----	-----	-----	-----	-----	-----	-----
6400	-----	-----	-----	-----	-----	-----	-----	-----	-----	-----
6750	-----	-----	-----	-----	-----	-----	-----	-----	-----	-----
7100	-----	-----	-----	-----	-----	-----	-----	-----	-----	-----
7500	-----	-----	-----	-----	-----	-----	-----	-----	-----	-----

Std Static Motor and Drive – 514–680 RPM, Max BHP 2.2

Medium Static Motor and Drive – 614–780 RPM, Max BHP 3.3

High Static Motor and Drive – 746–912 RPM, Max BHP 4.9

----- Outside operating range

Boldface – Field-supplied Drive

Table 22 – RGH213, 17.5 TON HORIZONTAL SUPPLY / RETURN

CFM	Available External Static Pressure (in. wg)									
	0.2		0.4		0.6		0.8		1.0	
	RPM	BHP	RPM	BHP	RPM	BHP	RPM	BHP	RPM	BHP
5250	587	1.62	650	2.11	708	2.63	761	3.18	811	3.77
5700	626	1.98	686	2.51	740	3.05	791	3.63	840	4.25
6100	661	2.35	718	2.91	771	3.48	820	4.09	866	4.73
6500	696	2.76	751	3.36	802	3.96	849	4.59	894	5.25
7000	741	3.34	793	3.99	841	4.63	886	5.30	929	5.99
7500	786	4.01	836	4.70	882	5.39	925	6.09	-----	-----
7900	823	4.60	871	5.34	915	6.06	-----	-----	-----	-----
8300	860	5.26	906	6.03	-----	-----	-----	-----	-----	-----
8750	901	6.06	-----	-----	-----	-----	-----	-----	-----	-----

CFM	Available External Static Pressure (in. wg)									
	1.2		1.4		1.6		1.8		2.0	
	RPM	BHP	RPM	BHP	RPM	BHP	RPM	BHP	RPM	BHP
5250	858	4.40	902	5.05	943	5.72	983	6.41	-----	-----
5700	885	4.90	928	5.58	969	6.28	-----	-----	-----	-----
6100	911	5.40	953	6.10	-----	-----	-----	-----	-----	-----
6500	937	5.94	-----	-----	-----	-----	-----	-----	-----	-----
7000	-----	-----	-----	-----	-----	-----	-----	-----	-----	-----
7500	-----	-----	-----	-----	-----	-----	-----	-----	-----	-----
7900	-----	-----	-----	-----	-----	-----	-----	-----	-----	-----
8300	-----	-----	-----	-----	-----	-----	-----	-----	-----	-----
8750	-----	-----	-----	-----	-----	-----	-----	-----	-----	-----

Std Static Motor and Drive – 622–822 RPM, Max BHP 3.3

Medium Static Motor and Drive – 713–879 RPM, Max BHP 4.9

High Static Motor and Drive – 882–1078 RPM, Max BHP 6.5

----- Outside operating range

Boldface – Field-supplied Drive

FAN PERFORMANCE (cont.)

Table 23 – RGH243, 20 TON HORIZONTAL SUPPLY / RETURN

CFM	Available External Static Pressure (in. wg)									
	0.2		0.4		0.6		0.8		1.0	
	RPM	BHP	RPM	BHP	RPM	BHP	RPM	BHP	RPM	BHP
6000	651	2.25	709	2.78	762	3.35	812	3.96	858	4.60
6500	696	2.77	750	3.33	801	3.94	848	4.57	893	5.24
7000	741	3.37	792	3.96	840	4.60	886	5.27	929	5.97
7500	787	4.05	834	4.67	880	5.34	924	6.05	965	6.78
8000	833	4.83	878	5.48	921	6.18	963	6.92	1003	7.69
8500	879	5.70	922	6.39	963	7.13	1003	7.89	1042	8.69
9000	926	6.69	966	7.41	1006	8.17	-----	-----	-----	-----
9500	973	7.78	1011	8.54	-----	-----	-----	-----	-----	-----
10000	-----	-----	-----	-----	-----	-----	-----	-----	-----	-----

CFM	Available External Static Pressure (in. wg)									
	1.2		1.4		1.6		1.8		2.0	
	RPM	BHP	RPM	BHP	RPM	BHP	RPM	BHP	RPM	BHP
6000	902	5.25	943	5.93	983	6.62	1021	7.32	1057	8.04
6500	935	5.94	976	6.65	1014	7.38	1051	8.12	1086	8.88
7000	970	6.70	1009	7.44	1046	8.21	-----	-----	-----	-----
7500	1005	7.54	1043	8.32	-----	-----	-----	-----	-----	-----
8000	1042	8.48	-----	-----	-----	-----	-----	-----	-----	-----
8500	-----	-----	-----	-----	-----	-----	-----	-----	-----	-----
9000	-----	-----	-----	-----	-----	-----	-----	-----	-----	-----
9500	-----	-----	-----	-----	-----	-----	-----	-----	-----	-----
10000	-----	-----	-----	-----	-----	-----	-----	-----	-----	-----

Std Static Motor and Drive – 690–863 RPM, Max BHP 4.9

Medium Static Motor and Drive – 835–1021 RPM, Max BHP 6.5

High Static Motor and Drive – 941–1176 RPM, Max BHP 8.7

----- Outside operating range

Boldface – Field-supplied Drive

Table 24 – RGH303, 25 TON HORIZONTAL SUPPLY / RETURN

CFM	Available External Static Pressure (in. wg)									
	0.2		0.4		0.6		0.8		1.0	
	RPM	BHP	RPM	BHP	RPM	BHP	RPM	BHP	RPM	BHP
7500	715	3.12	767	3.68	815	4.28	862	4.90	906	5.58
8000	751	3.65	800	4.25	847	4.87	892	5.53	934	6.21
8500	786	4.24	834	4.86	879	5.51	922	6.19	963	6.90
9000	822	4.88	867	5.53	910	6.21	952	6.91	991	7.64
9500	856	5.57	916	6.25	941	6.95	981	7.68	1020	8.44
10000	890	6.33	932	7.03	973	7.76	1011	8.52	-----	-----
10500	924	7.14	965	7.87	1004	8.62	-----	-----	-----	-----
11000	958	8.01	997	8.70	-----	-----	-----	-----	-----	-----
11500	991	8.94	1029	9.73	-----	-----	-----	-----	-----	-----

CFM	Available External Static Pressure (in. wg)									
	1.2		1.4		1.6		1.8		2.0	
	RPM	BHP	RPM	BHP	RPM	BHP	RPM	BHP	RPM	BHP
7500	948	6.27	988	6.98	1027	7.72	1065	8.49	-----	-----
8000	975	6.93	1014	7.67	1052	8.43	-----	-----	-----	-----
8500	1002	7.64	1041	8.40	-----	-----	-----	-----	-----	-----
9000	1030	8.41	-----	-----	-----	-----	-----	-----	-----	-----
9500	-----	-----	-----	-----	-----	-----	-----	-----	-----	-----
10000	-----	-----	-----	-----	-----	-----	-----	-----	-----	-----
10500	-----	-----	-----	-----	-----	-----	-----	-----	-----	-----
11000	-----	-----	-----	-----	-----	-----	-----	-----	-----	-----
11500	-----	-----	-----	-----	-----	-----	-----	-----	-----	-----

Std Static Motor and Drive – 647–791 RPM, Max BHP 4.9

Medium Static Motor and Drive – 755–923 RPM, Max BHP 6.5

High Static Motor and Drive – 827–1010 RPM, Max BHP 8.7

----- Outside operating range

Boldface – Field-supplied Drive

FAN PERFORMANCE (cont.)

Table 25 – PULLEY ADJUSTMENT

Unit RGH	MOTOR/DRIVE COMBO	MOTOR PULLEY TURNS OPEN										
		0	0.5	1	1.5	2	2.5	3	3.5	4	4.5	5
181 – 183	Standard Static	680	663	647	630	614	597	580	564	547	531	514
	Medium Static	863	845	826	808	789	771	753	734	716	697	679
	High Static	1009	991	972	954	936	918	899	881	863	844	826
210 – 213	Standard Static	822	802	782	762	742	722	702	682	662	642	622
	Medium Static	879	862	846	829	813	796	779	763	746	730	713
	High Static	1078	1058	1039	1019	1000	980	960	941	921	902	882
240 – 243	Standard Static	863	846	828	811	794	777	759	742	725	707	690
	Medium Static	1021	1002	984	965	947	928	909	891	872	854	835
	High Static	1176	1153	1129	1106	1082	1059	1035	1012	988	965	941
300 – 303	Standard Static	911	892	872	853	833	814	795	775	756	736	717
	Medium Static	1116	1096	1075	1055	1035	1015	994	974	954	933	913
	High Static	1176	1153	1129	1106	1082	1059	1035	1012	988	965	941

NOTE: Do not adjust pulley further than 5 turns open.

■ – Factory settings

DAMPER, BAROMETRIC RELIEF, AND PERFORMANCE, 15 to 25 Ton

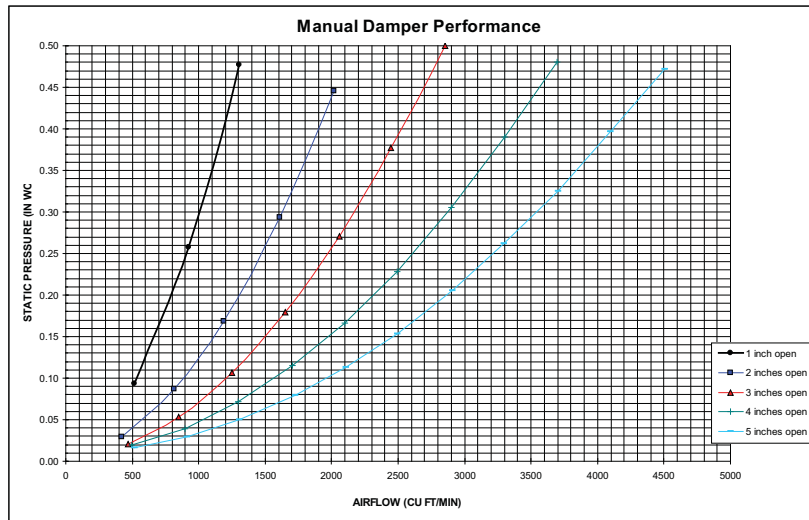

Fig 1 - Manual Damper Performance

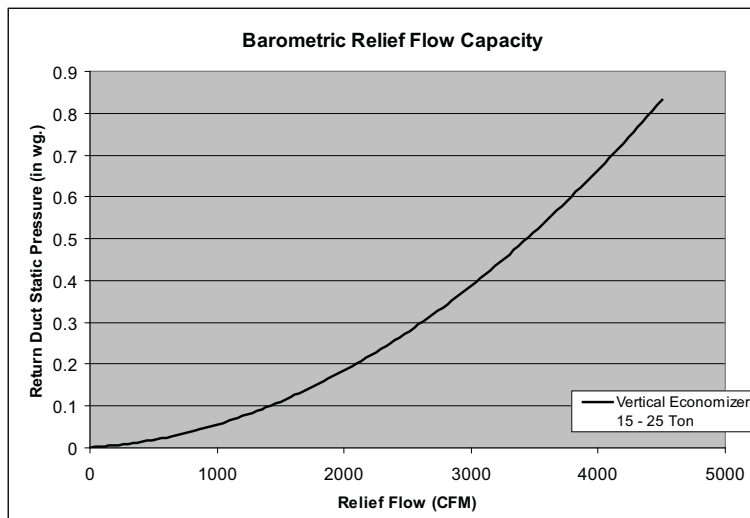

Fig 2 - Barometric Relief Flow Capacity

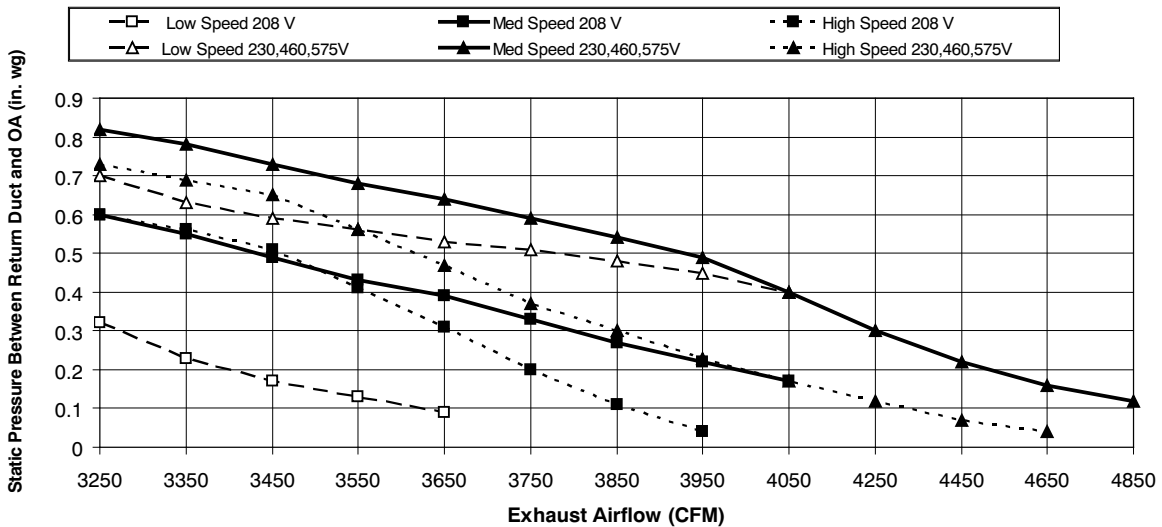

Fig 3 - Power Exhaust Fan Performance

ELECTRICAL DATA FOR UNITS PRODUCED ON OR AFTER JULY 30, 2012

NOTE: Check the serial number of unit to verify production date.

To confirm the date of manufacture of a RGH unit, locate the unit nameplate and check the second thru fifth digits of the Serial Number. If the number listed in the first 2nd thru 5th digits of the Serial Number is 1231 or higher the unit was produced after July 30, 2012.

SERIAL NUMBER

1	2	3	4	5	6	7	8	9	10
U	1	2	3	1	1	2	3	4	5

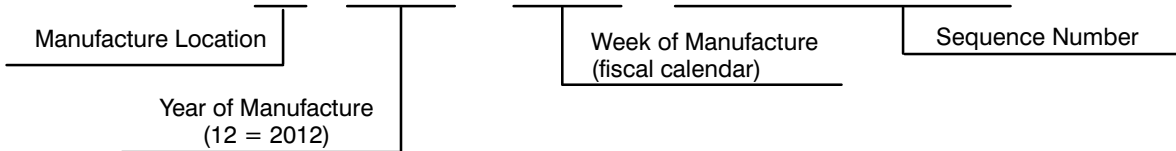

ELECTRICAL INFORMATION (UNITS PRODUCED ON OR AFTER JULY 30, 2012)

TABLE 26 – 2-STAGE COOLING WITH SINGLE SPEED INDOOR FAN MOTOR

UNIT RGH	V-Ph-Hz	VOLTAGE RANGE		COMP 1		COMP 2		OFM (ea)		IFM		
		MIN	MAX	RLA	LRA	RLA	LRA	WATTS	FLA	TYPE	EFF at Full Load	FLA
180/181	208-3-60	187	253	25.0	164	25.0	164	350	1.5	STD	88.6%	8.4
										MED	87.0%	10.6
										HIGH	82.9%	13.6
	230-3-60	187	253	25.0	164	25.0	164	350	1.5	STD	88.6%	8.3
										MED	87.0%	10.6
										HIGH	82.9%	12.7
	460-3-60	414	506	12.8	100	12.8	100	277	0.9	STD	88.6%	4.2
										MED	87.0%	5.3
										HIGH	82.9%	6.4
	575-3-60	518	633	9.6	78	9.6	78	397	0.6	STD	81.1%	2.8
										MED	81.1%	2.8
										HIGH	83.6%	5.6
210/213	208-3-60	187	253	27.6	191	25.0	164	350	1.5	STD	87.0%	10.6
										MED	82.9%	13.6
										HIGH	89.5%	17.1
	230-3-60	187	253	27.6	191	25.0	164	350	1.5	STD	87.0%	10.6
										MED	82.9%	12.7
										HIGH	89.5%	17.1
	460-3-60	414	506	12.8	100	12.2	100	277	0.9	STD	87.0%	5.3
										MED	82.9%	6.4
										HIGH	89.5%	8.6
	575-3-60	518	633	9.6	78	9.0	78	397	0.6	STD	81.1%	2.8
										MED	83.6%	5.6
										HIGH	89.5%	7.6
240/243	208-3-60	187	253	30.1	225	30.1	225	350	1.5	STD	82.9%	13.6
										MED	89.5%	17.1
										HIGH	91.7%	28.5
	230-3-60	187	253	30.1	225	30.1	225	350	1.5	STD	82.9%	12.7
										MED	89.5%	17.1
										HIGH	91.7%	28.5
	460-3-60	414	506	16.7	114	16.7	114	277	0.9	STD	82.9%	6.4
										MED	89.5%	8.6
										HIGH	91.7%	14.3
	575-3-60	518	633	12.2	80	12.2	80	397	0.6	STD	83.6%	5.6
										MED	89.5%	7.6
										HIGH	91.7%	9.5
300	208-3-60	187	253	48.1	245	33.3	239	350	1.5	STD	82.9%	13.6
										MED	89.5%	17.1
										HIGH	91.7%	28.5
	230-3-60	187	253	48.1	245	33.3	239	350	1.5	STD	82.9%	12.7
										MED	89.5%	17.1
										HIGH	91.7%	28.5
	460-3-60	414	506	18.6	125	17.9	125	277	0.9	STD	82.9%	6.4
										MED	89.5%	8.6
										HIGH	91.7%	14.3
	575-3-60	518	633	14.7	100	12.8	80	397	0.6	STD	83.6%	5.6
										MED	89.5%	7.6
										HIGH	91.7%	9.5

ELECTRICAL INFORMATION (UNITS PRODUCED ON OR AFTER JULY 30, 2012) (Cont.)

TABLE 27 – 2-STAGE COOLING WITH 2-SPEED INDOOR FAN MOTOR

UNIT RGH	V-Ph-Hz	VOLTAGE RANGE		COMP 1		COMP 2		OFM (ea)		IFM		
		MIN	MAX	RLA	LRA	RLA	LRA	WATTS	FLA	TYPE	EFF at Full Load	FLA
181/183	208-3-60	187	253	25.0	164	25.0	164	350	1.5	STD	85.0%	8.6
										MED	81.5%	10.8
										HIGH	83.6%	13.6
	230-3-60	187	253	25.0	164	25.0	164	350	1.5	STD	85.0%	7.8
										MED	81.5%	9.8
										HIGH	83.6%	12.7
	460-3-60	414	506	12.8	100	12.8	100	277	0.9	STD	85.0%	3.8
										MED	81.5%	4.9
										HIGH	83.6%	6.4
	575-3-60	518	633	9.6	78	9.6	78	397	0.6	STD	81.1%	4.5
										MED	81.1%	4.5
										HIGH	83.6%	6.2
210/213	208-3-60	187	253	27.6	191	25.0	164	350	1.5	STD	81.5%	10.8
										MED	83.6%	13.6
										HIGH	89.5%	17.1
	230-3-60	187	253	27.6	191	25.0	164	350	1.5	STD	81.5%	9.8
										MED	83.6%	12.7
										HIGH	89.5%	17.1
	460-3-60	414	506	12.8	100	12.2	100	277	0.9	STD	81.5%	4.9
										MED	83.6%	6.4
										HIGH	89.5%	8.6
	575-3-60	518	633	9.6	78	9.0	78	397	0.6	STD	81.1%	4.5
										MED	83.6%	6.2
										HIGH	89.5%	7.6
240/243	208-3-60	187	253	30.1	225	30.1	225	350	1.5	STD	83.6%	13.6
										MED	89.5%	17.1
										HIGH	91.7%	28.5
	230-3-60	187	253	30.1	225	30.1	225	350	1.5	STD	83.6%	12.7
										MED	89.5%	17.1
										HIGH	91.7%	28.5
	460-3-60	414	506	16.7	114	16.7	114	277	0.9	STD	83.6%	6.4
										MED	89.5%	8.6
										HIGH	91.7%	14.3
	575-3-60	518	633	12.2	80	12.2	80	397	0.6	STD	83.6%	6.2
										MED	89.5%	7.6
										HIGH	91.7%	9.5
300/303	208-3-60	187	253	48.1	245	33.3	239	350	1.5	STD	83.6%	13.6
										MED	89.5%	17.1
										HIGH	91.7%	28.5
	230-3-60	187	253	48.1	245	33.3	239	350	1.5	STD	83.6%	12.7
										MED	89.5%	17.1
										HIGH	91.7%	28.5
	460-3-60	414	506	18.6	125	17.9	125	277	0.9	STD	83.6%	6.4
										MED	89.5%	8.6
										HIGH	91.7%	14.3
	575-3-60	518	633	14.7	100	12.8	80	397	0.6	STD	83.6%	6.2
										MED	89.5%	7.6
										HIGH	91.7%	9.5

ELECTRICAL INFORMATION (UNITS PRODUCED ON OR AFTER JULY 30, 2012) (Cont.)

TABLE 28 – UNIT WIRE/FUSE OR HACR BREAKER SIZING DATA

UNIT RGH	NOM. V–Ph–Hz	IFM TYPE	NO C.O. or UNPWR C.O.							
			NO P.E.				w/ P.E. (pwrd fr/ unit)			
			MCA	MAX FUSE or HACR BRKR	DISC. SIZE		MCA	MAX FUSE or HACR BRKR	DISC. SIZE	
					FLA	LRA			FLA	LRA
181/183	208/230–3–60	STD	69.2/69.1	90/90	72/72	409	81.0/80.9	100/100	86/86	429
		MED	71.4	90	75	423	83.2	100	88	443
		HIGH	74.4/73.5	90/90	78/77	425	86.2/85.3	100/100	92/91	445
	460–3–60	STD	35.7	45	37	242	41.9	50	45	254
		MED	36.8	45	39	249	43.0	50	46	261
		HIGH	37.9	50	40	250	44.1	50	47	262
	575–3–60	STD	26.2	30	27	184	31	40	33	192
		MED	26.2	30	27	184	31.0	40	33	192
		HIGH	29	35	31	198	33.8	40	36	206
210/213	208/230–3–60	STD	76.1	100	80	453	87.9	100	93	473
		MED	79.1/78.2	100/100	83/82	455	90.9/90.0	100/100	97/96	475
		HIGH	82.6	100	87	451	94.4	110	101	471
	460–3–60	STD	37.1	45	39	251	43.3	50	46	263
		MED	38.2	50	40	252	44.4	50	47	264
		HIGH	40.4	50	43	250	46.6	50	50	262
	575–3–60	STD	26.2	30	27	186	31	40	33	194
		MED	29.0	35	31	200	33.8	40	36	208
		HIGH	31	40	33	198	35.8	45	38	206
240/243	208/230–3–60	STD	87.3/86.4	100/100	92/91	550	99.1/98.2	125/125	105/104	570
		MED	90.8	100	96	546	102.6	125	109	566
		HIGH	102.2	125	109	625	114.0	125	122	645
	460–3–60	STD	47.6	60	50	280	53.8	60	57	292
		MED	49.8	60	52	278	56.0	70	60	290
		HIGH	55.5	60	59	318	61.7	70	66	330
	575–3–60	STD	35.5	45	37	204	40.3	50	43	212
		MED	37.5	45	40	202	42.3	50	45	210
		HIGH	39.4	50	42	229	44.2	50	47	237
300/303	208/230–3–60	STD	116.0/115.1	150/150	120/119	590	127.8/126.9	175/175	133/132	610
		MED	119.5	150	124	586	131.3	175	137	606
		HIGH	130.9	175	137	665	142.7	175	150	685
	460–3–60	STD	53	60	56	306	59.2	70	63	318
		MED	55.2	60	58	304	61.4	70	65	316
		HIGH	60.9	70	65	344	67.1	80	72	356
	575–3–60	STD	40.4	50	42	228	45.2	50	48	236
		MED	42.4	50	45	226	47.2	60	50	234
		HIGH	44.3	50	47	253	49.1	60	52	261

ELECTRICAL INFORMATION (UNITS PRODUCED ON OR AFTER JULY 30, 2012) (Cont.)

TABLE 29 – UNIT WIRE SIZING DATA WITH FACTORY INSTALLED 2 SPEED INDOOR FAN OPTION

UNIT RGH	NOM. V–Ph–Hz	IFM TYPE	NO C.O. or UNPWR C.O.							
			NO P.E.				w/ P.E. (pwrd fr/ unit)			
			MCA	MAX FUSE or HACR BRKR	DISC. SIZE		MCA	MAX FUSE or HACR BRKR	DISC. SIZE	
					FLA	LRA			FLA	LRA
181/183	208/230–3–60	STD	69.4/68.6	90/90	73/72	390	81.2/80.4	100/100	86/85	410
		MED	71.6/70.6	90/90	75/74	414	83.4/82.4	100/100	89/88	434
		HIGH	74.4/73.5	90/90	78/77	425	86.2/85.3	100/100	92/91	445
	460–3–60	STD	35.3	45	37	233	41.5	50	44	245
		MED	36.4	45	38	245	42.6	50	45	257
		HIGH	37.9	50	40	250	44.1	50	47	262
	575–3–60	STD	27.9	35	29	184	32.7	40	35	192
		MED	27.9	35	29	184	32.7	40	35	192
		HIGH	29.6	35	31	198	34.4	40	37	206
210/213	208/230–3–60	STD	76.3/75.3	100/100	80/79	444	88.1/87.1	100/100	93/92	464
		MED	79.1/78.2	100/100	83/82	455	90.9/90.0	100/100	97/96	475
		HIGH	82.6	100	87	451	94.4	110	101	471
	460–3–60	STD	36.7	45	39	247	42.9	50	46	259
		MED	38.2	50	40	252	44.4	50	47	264
		HIGH	40.4	50	43	250	46.6	50	50	262
	575–3–60	STD	27.9	35	29	186	32.7	40	35	194
		MED	29.6	35	31	200	34.4	40	37	208
		HIGH	31.0	40	33	198	35.8	45	38	206
240/243	208/230–3–60	STD	87.3/86.4	100/100	92/91	550	99.1/98.2	125/125	105/104	570
		MED	90.8	100	96	546	102.6	125	109	566
		HIGH	102.2	125	109	625	114.0	125	122	645
	460–3–60	STD	47.6	60	50	280	53.8	60	57	292
		MED	49.8	60	52	278	56.0	70	60	290
		HIGH	55.5	60	59	318	61.7	70	66	330
	575–3–60	STD	36.1	45	38	204	40.9	50	43	212
		MED	37.5	45	40	202	42.3	50	45	210
		HIGH	39.4	50	42	229	44.2	50	47	237
300/303	208/230–3–60	STD	116.0/115.1	150/150	120/119	590	127.8/126.9	175/175	133/132	610
		MED	119.5	150	124	586	131.3	175	137	606
		HIGH	130.9	175	137	665	142.7	175	150	685
	460–3–60	STD	53.0	60	56	306	59.2	70	63	318
		MED	55.2	60	58	304	61.4	70	65	316
		HIGH	60.9	70	65	344	67.1	80	72	356
	575–3–60	STD	41.0	50	43	228	45.8	60	48	236
		MED	42.4	50	45	226	47.2	60	50	234
		HIGH	44.3	50	47	253	49.1	60	52	261

LEGEND:

- BRKR – Circuit breaker
- CO – Convenience outlet
- DISC – Disconnect
- FLA – Full load amps
- IFM – Indoor fan motor
- LRA – Locked rotor amps
- MCA – Minimum circuit amps
- MOCB – MAX FUSE or HACR Breaker
- PE – Power exhaust
- UNPWR CO – Unpowered convenient outlet



Example: Supply voltage is 230-3-60



- AB = 224 v
- BC = 231 v
- AC = 226 v

$$\text{Average Voltage} = \frac{(224 + 231 + 226)}{3} = \frac{681}{3} = 227$$

Determine maximum deviation from average voltage.

- (AB) 227 – 224 = 3 v
- (BC) 231 – 227 = 4 v
- (AC) 227 – 226 = 1 v

Maximum deviation is 4 v.

Determine percent of voltage imbalance.

$$\% \text{ Voltage Imbalance} = 100 \times \frac{4}{227} = 1.76\%$$

This amount of phase imbalance is satisfactory as it is below the maximum allowable 2%.

IMPORTANT: If the supply voltage phase imbalance is more than 2%, contact your local electric utility company immediately.

NOTES:

In compliance with NEC requirements for multimotor and combination load equipment (refer to NEC Articles 430 and 440), the overcurrent protective device for the unit shall be fuse or HACR breaker. Canadian units may be fuse or circuit breaker.

Unbalanced 3-Phase Supply Voltage

Never operate a motor where a phase imbalance in supply voltage is greater than 2%. Use the following formula to determine the percentage of voltage imbalance.

$$\% \text{ Voltage Imbalance} = 100 \times \frac{\text{max voltage deviation from average voltage}}{\text{average voltage}}$$

ELECTRICAL INFORMATION (UNITS PRODUCED PRIOR TO JULY 30, 2012)

NOTE: Check the serial number of unit to verify production date.

To confirm the date of manufacture of a RGH unit, locate the unit nameplate and check the second thru fifth digits of the Serial Number. If the number listed in the first 2nd thru 5th digits of the Serial Number is 1230 or lower the unit was produced prior to July 30, 2012.

SERIAL NUMBER

1	2	3	4	5	6	7	8	9	10
U	1	2	3	1	1	2	3	4	5

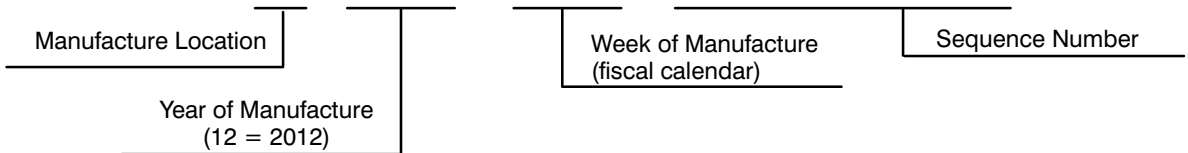

ELECTRICAL INFORMATION (UNITS PRODUCED PRIOR TO JULY 30, 2012)

TABLE 30 – 2-STAGE COOLING WITH SINGLE SPEED INDOOR FAN MOTOR

UNIT RGH	V-PH-HZ	VOLTAGE RANGE		COMP 1		COMP 2		OFM (ea)		IFM		
		MIN	MAX	RLA	LRA	RLA	LRA	WATTS	FLA	TYPE	EFF at Full Load	FLA
181/183	208-3-60	187	253	29.5	195	30.1	225	350	1.5	STD	81.3%	7.5
										MED	83.8%	10.2
										HIGH	83.6%	15.0
	230-3-60	187	253	29.5	195	30.1	225	350	1.5	STD	81.3%	7.5
										MED	83.8%	10.2
										HIGH	83.6%	15.0
	460-3-60	414	506	14.7	95	16.7	114	277	0.9	STD	81.3%	3.4
										MED	83.8%	4.8
										HIGH	83.6%	7.4
	575-3-60	518	633	12.2	80	12.2	80	397	0.6	STD	81.1%	2.8
										MED	81.1%	2.8
										HIGH	83.6%	5.6
210/213	208-3-60	187	253	29.5	195	30.1	225	350	1.5	STD	83.8%	10.2
										MED	83.6%	15.0
										HIGH	89.5%	20.4
	230-3-60	187	253	29.5	195	30.1	225	350	1.5	STD	83.8%	10.2
										MED	83.6%	15.0
										HIGH	89.5%	20.4
	460-3-60	414	506	14.7	95	16.7	114	277	0.9	STD	83.8%	4.8
										MED	83.6%	7.4
										HIGH	89.5%	20.4
	575-3-60	518	633	12.2	80	12.2	80	397	0.6	STD	81.1%	2.8
										MED	83.6%	5.6
										HIGH	89.5%	9.0
240/243	208-3-60	187	253	48.1	245	29.5	195	350	1.5	STD	83.6%	15.0
										MED	89.5%	20.4
										HIGH	91.7%	33.1
	230-3-60	187	253	48.1	245	29.5	195	350	1.5	STD	83.6%	15.0
										MED	89.5%	20.4
										HIGH	91.7%	33.1
	460-3-60	414	506	18.6	125	14.7	95	277	0.9	STD	83.6%	7.4
										MED	89.5%	20.4
										HIGH	91.7%	33.1
	575-3-60	518	633	14.7	100	12.2	80	397	0.6	STD	83.6%	5.6
										MED	89.5%	9.0
										HIGH	91.7%	9.5
300	208-3-60	187	253	48.1	245	48.1	245	350	1.5	STD	83.6%	15.0
										MED	89.5%	20.4
										HIGH	91.7%	33.1
	230-3-60	187	253	48.1	245	48.1	245	350	1.5	STD	83.6%	15.0
										MED	89.5%	20.4
										HIGH	91.7%	33.1
	460-3-60	414	506	18.6	125	18.6	125	277	0.9	STD	83.6%	7.4
										MED	89.5%	20.4
										HIGH	91.7%	33.1
	575-3-60	518	633	14.7	100	14.7	100	397	0.6	STD	83.6%	5.6
										MED	89.5%	9.0
										HIGH	91.7%	9.5

ELECTRICAL INFORMATION

(UNITS PRODUCED PRIOR TO JULY 30, 2012) (CONT.)

TABLE 31 – 2-STAGE COOLING WITH 2-SPEED INDOOR FAN MOTOR

UNIT RGH	V-Ph-Hz	VOLTAGE RANGE		COMP 1		COMP 2		OFM (ea)		IFM		
		MIN	MAX	RLA	LRA	RLA	LRA	WATTS	FLA	TYPE	EFF at Full Load	FLA
181/183	208-3-60	187	253	25.0	164	25.0	164	350	1.5	STD	85.0%	8.6
										MED	81.5%	10.8
										HIGH	83.6%	13.6
	230-3-60	187	253	25.0	164	25.0	164	350	1.5	STD	85.0%	7.8
										MED	81.5%	9.8
										HIGH	83.6%	12.7
	460-3-60	414	506	12.8	100	12.8	100	277	0.9	STD	85.0%	3.8
										MED	81.5%	4.9
										HIGH	83.6%	6.4
	575-3-60	518	633	9.6	78	9.6	78	397	0.6	STD	81.1%	4.5
										MED	81.1%	4.5
										HIGH	83.6%	6.2
210/213	208-3-60	187	253	27.6	191	25.0	164	350	1.5	STD	81.5%	10.8
										MED	83.6%	13.6
										HIGH	89.5%	17.1
	230-3-60	187	253	27.6	191	25.0	164	350	1.5	STD	81.5%	9.8
										MED	83.6%	12.7
										HIGH	89.5%	17.1
	460-3-60	414	506	12.8	100	12.2	100	277	0.9	STD	81.5%	4.9
										MED	83.6%	6.4
										HIGH	89.5%	8.6
	575-3-60	518	633	9.6	78	9.0	78	397	0.6	STD	81.1%	4.5
										MED	83.6%	6.2
										HIGH	89.5%	7.6
240/243	208-3-60	187	253	30.1	225	30.1	225	350	1.5	STD	83.6%	13.6
										MED	89.5%	17.1
										HIGH	91.7%	28.5
	230-3-60	187	253	30.1	225	30.1	225	350	1.5	STD	83.6%	12.7
										MED	89.5%	17.1
										HIGH	91.7%	28.5
	460-3-60	414	506	16.7	114	16.7	114	277	0.9	STD	83.6%	6.4
										MED	89.5%	8.6
										HIGH	91.7%	14.3
	575-3-60	518	633	12.2	80	12.2	80	397	0.6	STD	83.6%	6.2
										MED	89.5%	7.6
										HIGH	91.7%	9.5
300/303	208-3-60	187	253	48.1	245	33.3	239	350	1.5	STD	83.6%	13.6
										MED	89.5%	17.1
										HIGH	91.7%	28.5
	230-3-60	187	253	48.1	245	33.3	239	350	1.5	STD	83.6%	12.7
										MED	89.5%	17.1
										HIGH	91.7%	28.5
	460-3-60	414	506	18.6	125	17.9	125	277	0.9	STD	83.6%	6.4
										MED	89.5%	8.6
										HIGH	91.7%	14.3
	575-3-60	518	633	14.7	100	12.8	80	397	0.6	STD	83.6%	6.2
										MED	89.5%	7.6
										HIGH	91.7%	9.5

ELECTRICAL INFORMATION

(UNITS PRODUCED PRIOR TO JULY 30, 2012) (CONT.)

TABLE 32 – UNIT WIRE/FUSE OR HACR BREAKER SIZING DATA

UNIT RGH	NOM. V–Ph–Hz	IFM TYPE	NO C.O. or UNPWR C.O.							
			NO PE.				w/ P.E. (pwrd fr/ unit)			
			MCA	MAX FUSE or HACR BRKR	DISC. SIZE		MCA	MAX FUSE or HACR BRKR	DISC. SIZE	
					FLA	LRA			FLA	LRA
180/181	208/ 230–3–60	STD	68.3	90	71	393	80.1	100	85	413
		MED	71.0	90	74	410	82.8	100	88	430
		HIGH	75.8	100	80	419	87.6	100	93	439
	460–3–60	STD	34.9	45	36	234	41.1	50	44	246
		MED	36.3	45	38	243	42.5	50	45	255
		HIGH	38.9	50	41	247	45.1	50	48	259
	575–3–60	STD	26.2	30	27	184	31.0	40	33	192
		MED	26.2	30	27	184	31.0	40	33	192
		HIGH	29.0	35	31	198	33.8	40	36	206
210/213	208/ 230–3–60	STD	75.7	100	79	440	87.5	100	93	460
		MED	80.5	100	85	449	92.3	100	98	469
		HIGH	82.6	100	87	451	94.4	110	101	471
	460–3–60	STD	36.6	45	38	245	42.8	50	46	257
		MED	39.2	50	41	249	45.4	50	49	261
		HIGH	40.4	50	43	250	46.6	50	50	262
	575–3–60	STD	26.2	30	27	186	31.0	40	33	194
		MED	29.0	35	31	200	33.8	40	36	208
		HIGH	31.0	40	33	198	35.8	45	38	206
240/243	208/ 230–3–60	STD	88.7	100	93	544	100.5	125	107	564
		MED	90.8	100	96	546	102.6	125	109	566
		HIGH	102.2	125	109	625	114.0	125	122	645
	460–3–60	STD	48.6	60	51	277	54.8	60	58	289
		MED	49.8	60	52	278	56.0	70	60	290
		HIGH	55.5	60	59	318	61.7	70	66	330
	575–3–60	STD	35.5	45	37	204	40.3	50	43	212
		MED	37.5	45	40	202	42.3	50	45	210
		HIGH	39.4	50	42	229	44.2	50	47	237
300/303	208/ 230–3–60	STD	117.4	150	121	584	129.2	175	135	604
		MED	119.5	150	124	586	131.3	175	137	606
		HIGH	130.9	175	137	665	142.7	175	150	685
	460–3–60	STD	54.0	60	57	303	60.2	70	64	315
		MED	55.2	60	58	304	61.4	70	65	316
		HIGH	60.9	70	65	344	67.1	80	72	356
	575–3–60	STD	40.4	50	42	228	45.2	50	48	236
		MED	42.4	50	45	226	47.2	60	50	234
		HIGH	44.3	50	47	253	49.1	60	52	261

ELECTRICAL INFORMATION

(UNITS PRODUCED PRIOR TO JULY 30, 2012) (CONT.)

TABLE 33 – UNIT WIRE SIZING DATA WITH FACTORY INSTALLED TWO SPEED INDOOR FAN OPTION

UNIT RGH	NOM. V–Ph–Hz	IFM TYPE	NO C.O. or UNPWR C.O.							
			NO PE.				w/ P.E. (pwrd fr/ unit)			
			MCA	MAX FUSE or HACR BRKR	DISC. SIZE		MCA	MAX FUSE or HACR BRKR	DISC. SIZE	
					FLA	LRA			FLA	LRA
181/183	208/ 230–3–60	STD	69.4/68.6	90/90	73/72	390	81.2/80.4	100/100	86/85	410
		MED	71.6/70.6	90/90	75/74	414	83.4/82.4	100/100	89/88	434
		HIGH	74.4/73.5	90/90	78/77	425	86.2/85.3	100/100	92/91	445
	460–3–60	STD	35.3	45	37	233	41.5	50	44	245
		MED	36.4	45	38	245	42.6	50	45	257
		HIGH	37.9	50	40	250	44.1	50	47	262
	575–3–60	STD	27.9	35	29	184	32.7	40	35	192
		MED	27.9	35	29	184	32.7	40	35	192
		HIGH	29.6	35	31	198	34.4	40	37	206
210/213	208/ 230–3–60	STD	76.3/75.3	100/100	80/79	444	88.1/87.1	100/100	93/92	464
		MED	79.1/78.2	100/100	83/82	455	90.9/90.0	100/100	97/96	475
		HIGH	82.6	100	87	451	94.4	110	101	471
	460–3–60	STD	36.7	45	39	247	42.9	50	46	259
		MED	38.2	50	40	252	44.4	50	47	264
		HIGH	40.4	50	43	250	46.6	50	50	262
	575–3–60	STD	27.9	35	29	186	32.7	40	35	194
		MED	29.6	35	31	200	34.4	40	37	208
		HIGH	31.0	40	33	198	35.8	45	38	206
240/243	208/ 230–3–60	STD	87.3/86.4	100/100	92/91	550	99.1/98.2	125/125	105/104	570
		MED	90.8	100	96	546	102.6	125	109	566
		HIGH	102.2	125	109	625	114.0	125	122	645
	460–3–60	STD	47.6	60	50	280	53.8	60	57	292
		MED	49.8	60	52	278	56.0	70	60	290
		HIGH	55.5	60	59	318	61.7	70	66	330
	575–3–60	STD	36.1	45	38	204	40.9	50	43	212
		MED	37.5	45	40	202	42.3	50	45	210
		HIGH	39.4	50	42	229	44.2	50	47	237
300/303	208/ 230–3–60	STD	116.0/115.1	150/150	120/119	590	127.8/126.9	175/175	133/132	610
		MED	119.5	150	124	586	131.3	175	137	606
		HIGH	130.9	175	137	665	142.7	175	150	685
	460–3–60	STD	53.0	60	56	306	59.2	70	63	318
		MED	55.2	60	58	304	61.4	70	65	316
		HIGH	60.9	70	65	344	67.1	80	72	356
	575–3–60	STD	41.0	50	43	228	45.8	60	48	236
		MED	42.4	50	45	226	47.2	60	50	234
		HIGH	44.3	50	47	253	49.1	60	52	261

SEQUENCE OF OPERATION

General

The sequence below describes the sequence of operation for an electro-mechanical unit with and without a factory installed economizer IV or X. For information regarding a direct digital controller, see the start-up, operations, and troubleshooting manual for the applicable controller.

Units with no economizer

Cooling —

When the field supplied commercial grade thermostat calls for cooling, terminals G and Y1 are energized. As a result, the indoor-fan contactor (IFC) and the compressor contactor (C1) are energized, causing the indoor-fan motor (IFM), compressor #1, and outdoor fan to start. If the unit has 2 stages of cooling, the thermostat will additionally energize Y2. The Y2 signal will energize compressor contactor #2 (C2), causing compressor #2 to start. Regardless of the number of stages, the outdoor-fan motor runs continuously while unit is cooling.

→ Cooling (2-speed indoor fan motor) —

Per ASHRAE 90.1 2016 standard, during the first stage of cooling operation the VFD will adjust the fan motor to provide 2/3rd of the total cfm established for the unit. When a call for the second stage of cooling is required, the VFD will allow the total cfm for the unit established (100%).

Heating —

NOTE: Units have 2 stages of gas heat.

When the field supplied commercial grade thermostat calls for heating, power is sent to W on the Integrated Gas Controller (IGC) board. An LED (light-emitting diode) on the IGC board turns on and remains on during normal operation. A check is made to ensure that the rollout switch and limit switch are closed. If the check was successful, the induced-draft motor is energized, and when its speed is satisfactory, as proven by the "hall effect" sensor, the ignition activation period begins. The burners will ignite within 5 seconds. If the burners do not light, there is a 22-second delay before another 5-second attempt. This sequence is repeated for 15 minutes or until the burners light. If, after the 15 minutes, the burners still have not lit, heating is locked out. To reset the control, break 24-v power to the thermostat.

When ignition occurs, the IGC board will continue to monitor the condition of the rollout switch, the limit switches, the "hall effect" sensor, as well as the flame sensor. 45 seconds after ignition occurs, assuming the unit is controlled through a room thermostat set for fan auto, the indoor-fan motor will energize (and the outdoor-air dampers will open to their minimum position). If, for some reason, the over-temperature limit opens prior to the start of the indoor fan blower, the unit will shorten the 45-second delay to 5 seconds less than the time from initiation of heat to when the limit tripped. Gas will not be interrupted to the burners and heating will continue. Once the fan-on delay has been modified, it will not change back to 45 seconds until power is reset to the control.

On units with 2 stages of heat, when additional heat is required, W2 closes and initiates power to the second stage of the main gas valve. When the thermostat is satisfied, W1 and W2 open and the gas valve closes, interrupting the flow of gas to the main burners.

If the call for W1 lasted less than 1 minute, the heating cycle will not terminate until 1 minute after W1 became active. If the unit is controlled through a room thermostat set for fan auto, the indoor-fan motor will continue to operate for an additional 45 seconds then stop. If the over-temperature limit opens after the

indoor motor is stopped, but within 10 minutes of W1 becoming inactive, on the next cycle the time will be extended by 15 seconds. The maximum delay is 3 minutes. Once modified, the fan off delay will not change back to 45 seconds unless power is reset to the control. A LED indicator is provided on the IGC to monitor operation.

Units with an Economizer

Cooling —

When free cooling is not available, the compressors will be controlled by the zone thermostat. When free cooling is available, the outdoor-air damper is modulated by the economizer IV or X control to provide a 50°F (10°C) to 55°F (13°C) mixed-air temperature into the zone. As the mixed air temperature fluctuates above 55°F (13°C) or below 50°F (10°C) dampers will be modulated (open or close) to bring the mixed-air temperature back within control. If mechanical cooling is utilized with free cooling, the outdoor-air damper will maintain its current position at the time the compressor is started. If the increase in cooling capacity causes the mixed-air temperature to drop below 45°F (7°C), then the outdoor-air damper position will be decreased to the minimum position. If the mixed-air temperature continues to fall, the outdoor-air damper will close. Control returns to normal once the mixed-air temperature rises above 48°F (9°C). The power exhaust fans will be energized and de-energized, if installed, as the outdoor-air damper opens and closes.

If field-installed accessory CO₂ sensors are connected to the economizer IV and X control, a demand controlled ventilation strategy will begin to operate. As the CO₂ level in the zone increases above the CO₂ setpoint, the minimum position of the damper will be increased proportionally. As the CO₂ level decreases because of the increase in fresh air, the outdoor-air damper will be proportionally closed. For economizer IV and X operation, there must be a thermostat call for the fan (G). If the unit is occupied and the fan is on, the damper will operate at minimum position. Otherwise, the damper will be closed.

When the economizer IV and X control is in the occupied mode and a call for cooling exists (Y1 on the thermostat), the control will first check for indoor fan operation. If the fan is not on, then cooling will not be activated. If the fan is on, then the control will open the economizer damper to the minimum position.

On the initial power to the economizer IV and X control, it will take the damper up to 2 1/2 minutes before it begins to position itself. After the initial power-up, further changes in damper position can take up to 30 seconds to initiate. Damper movement from full closed to full open (or vice versa) will take between 1 1/2 and 2 1/2 minutes. If free cooling can be used as determined from the appropriate changeover command (switch, dry bulb, enthalpy curve, differential dry bulb, or differential enthalpy), then the control will modulate the dampers open to maintain the mixed-air temperature setpoint at 50°F (10°C) to 55°F (13°C). If there is a further demand for cooling (cooling second stage – Y2 is energized), then the control will bring on compressor stage 1 to maintain the mixed-air temperature setpoint. The economizer IV and X damper will be open at maximum position. Economizer IV and X operation is limited to a single compressor.

SEQUENCE OF OPERATION (CONT.)

Heating —

The sequence of operation for the heating is the same as a unit with no economizer. The only difference is how the economizer acts. The economizer will stay at the Economizer Minimum Position while the evaporator fan is operating. The outdoor-air damper is closed when the indoor fan is not operating.

Refer to Service and Maintenance Manual for further details.

Optional Hot Gas Reheat Dehumidification System

Units with the factory equipped Hot Gas Reheat option are capable of providing multiple modes of improved dehumidification as a variation of the normal cooling cycle. The Hot Gas Reheat option includes additional valves in the liquid line and discharge line of each refrigerant circuit, a small reheat condenser coil downstream of the evaporator, and Motormaster variable-speed control of some or all outdoor fans. Operation of the revised refrigerant circuit for each mode is described below.

The Hot Gas Reheat system provides three sub-modes of operation: Cool, Reheat1, and Reheat2.

Cool mode – provides a normal ratio of Sensible and Latent Cooling effect from the evaporator coil.

Reheat1 – provides increased Latent Cooling while slightly reducing the Sensible Cooling effect.

Reheat2 – provides normal Latent Cooling but with null or minimum Sensible Cooling effect delivered to the space.

The Reheat1 and Reheat2 modes are available when the unit is not in a Heating mode and when the Low Ambient Lockout switch is closed.

SEQUENCE OF OPERATION (CONT.)

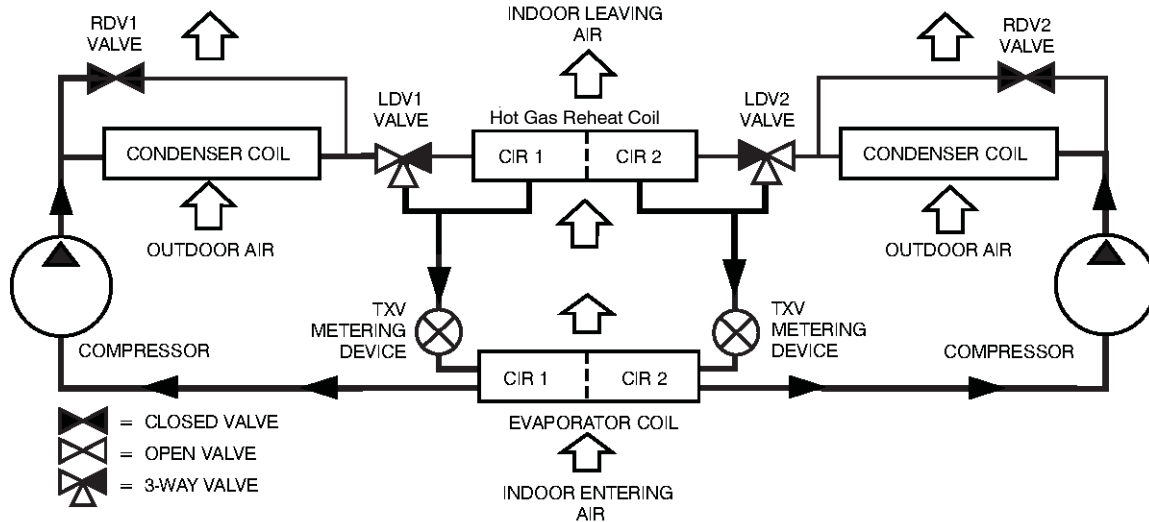

NORMAL COOLING MODE - HOT GAS REHEAT SYSTEM

C12705

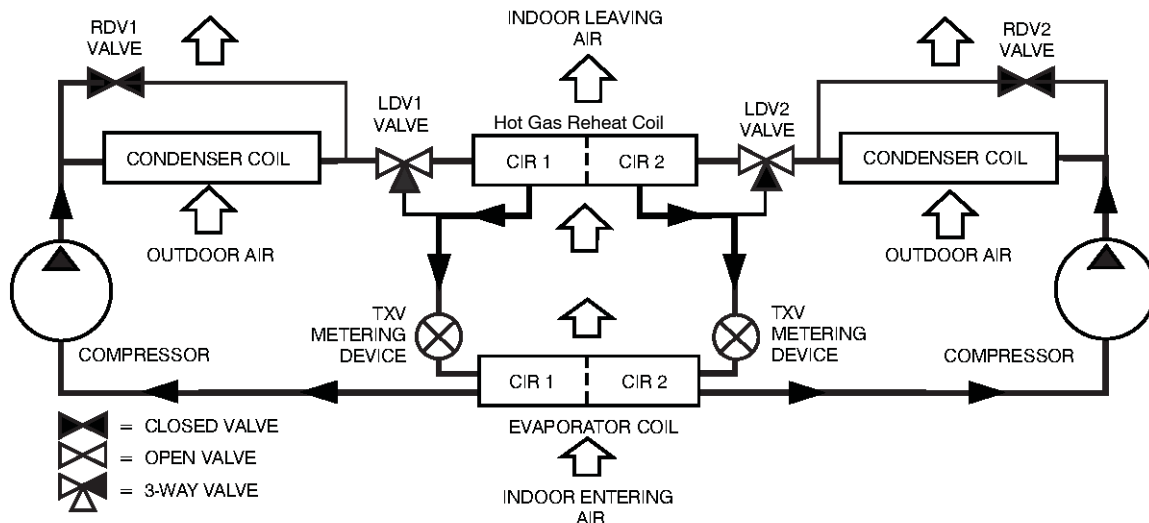

SUBCOOLING MODE (REHEAT 1) - HOT GAS REHEAT SYSTEM

C12706

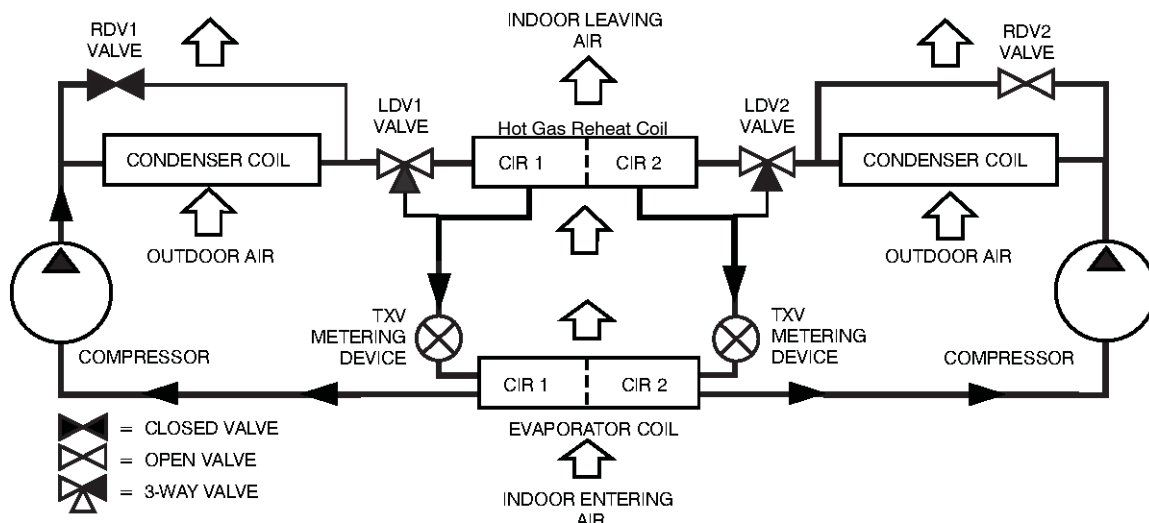

HOT GAS REHEAT (REHEAT 2) - HOT GAS REHEAT SYSTEM

C12707

GAS HEAT / ELECTRIC COOLING PACKAGED ROOFTOP

HVAC Guide Specifications

Size Range: 15 to 25 Nominal Tons

<u>Section</u>	<u>Description</u>
----------------	--------------------

23 06 80	Schedules for Decentralized HVAC Equipment
-----------------	---

23 06 80.13	Decentralized Unitary HVAC Equipment Schedule
-------------	---

23 06 80.13.A.	Rooftop unit schedule
----------------	-----------------------

1. Schedule is per the project specification requirements.

23 07 16	HVAC Equipment Insulation
-----------------	----------------------------------

23 07 16.13	Decentralized, Rooftop Units:
-------------	-------------------------------

23 07 16.13.A.	Evaporator fan compartment:
----------------	-----------------------------

1. Interior cabinet surfaces shall be insulated with a minimum 1/2-in. thick, minimum 1 1/2 lb density, flexible fiberglass insulation bonded with a phenolic binder, neoprene coated on the air side.
2. Insulation and adhesive shall meet NFPA 90A requirements for flame spread and smoke generation.

23 07 16.13.B.	Gas heat compartment:
----------------	-----------------------

1. Aluminum foil-faced fiberglass insulation shall be used.
2. Insulation and adhesive shall meet NFPA 90A requirements for flame spread and smoke generation.

23 09 13	Instrumentation and Control Devices for HVAC
-----------------	---

23 09 13.23	Sensors and Transmitters
-------------	--------------------------

23 09 13.23.A.	Thermostats
----------------	-------------

1. Thermostat must
 - a. energize both "W" and "G" when calling for heat.
 - b. have capability to energize 2 different stages of cooling, and 2 different stages of heating.
 - c. include capability for occupancy scheduling.

23 09 33	Electric and Electronic Control System for HVAC
-----------------	--

23 09 33.13	Decentralized, Rooftop Units:
-------------	-------------------------------

23 09 33.13.A.	General:
----------------	----------

1. Shall be complete with self-contained low-voltage control circuit protected by a resettable circuit breaker on the 24-v transformer side. Transformer shall have 75VA capability.
2. Shall utilize color-coded wiring.
3. Shall include a central control terminal board to conveniently and safely provide connection points for vital control functions such as: smoke detectors, phase monitor, gas controller, economizer, thermostat, and low and high pressure switches.
4. The heat exchanger shall be controlled by an integrated gas controller (IGC) microprocessor. See heat exchanger section of this specification.
5. Unit shall include a minimum of one 8-pin screw terminal connection board for connection of control wiring.

23 09 33.23.B.	Safeties:
----------------	-----------

1. Compressor over-temperature, over-current. High internal pressure differential.
2. Low-pressure switch.
 - a. Units shall have different sized connectors for the circuit 1 and circuit 2 low and high pressure switches. They shall physically prevent the cross-wiring of the safety switches between circuits 1 and 2.
 - b. Low pressure switch shall use different color wire than the high pressure switch. The purpose is to assist the installer and service technician to correctly wire and or troubleshoot the rooftop unit.

3. High-pressure switch.
 - a. Units shall have different sized connectors for the circuit 1 and circuit 2 low and high pressure switches. They shall physically prevent the cross-wiring of the safety switches between circuits 1 and 2.
 - b. High pressure switch shall use different color wire than the low pressure switch. The purpose is to assist the installer and service technician to correctly wire and or troubleshoot the rooftop unit.
4. Automatic reset, motor thermal overload protector.
5. Heating section shall be provided with the following minimum protections:
 - a. High-temperature limit switches.
 - b. Induced draft motor speed sensor.
 - c. Flame rollout switch.
 - d. Flame proving controls.

23 09 93 Sequence of Operations for HVAC Controls

23 09 93.13 Decentralized, Rooftop Units:

23 09 93.13 INSERT SEQUENCE OF OPERATION

23 40 13 Panel Air Filters

23 40 13.13 Decentralized, Rooftop Units:

23 40 13.13.A. Standard filter section

1. Shall consist of factory-installed, low velocity, disposable 2-in. thick fiberglass filters of commercially available sizes.
2. Unit shall use only one filter size. Multiple sizes are not acceptable.
3. Filters shall be accessible through a dedicated, weather tight access panel.
4. 4-in filter capabilities shall be capable with pre-engineered and approved filter track field installed accessory. This kit requires field furnished filters.

23 81 19 Self-Contained Air Conditioners

23 81 19.13 Medium-Capacity Self-Contained Air Conditioners (RGH181-303)

23 81 19.13.A. General

1. Outdoor, rooftop mounted, electrically controlled, heating and cooling unit utilizing a fully hermetic scroll compressor(s) for cooling duty and gas combustion for heating duty.
2. Factory assembled, single-piece heating and cooling rooftop unit. Contained within the unit enclosure shall be all factory wiring, piping, controls, and special features required prior to field start-up.
3. Unit shall use environmentally sound, R-410A refrigerant.
4. Unit shall be installed in accordance with the manufacturer's instructions.
5. Unit must be selected and installed in compliance with local, state, and federal codes.

→ 23 81 19.13.B. Quality Assurance

1. Unit meets or exceeds ASHRAE 90.1 2016 and IECC minimum efficiency requirements.
2. Units are Energy Star certified where sizes are required.
3. Unit shall be rated in accordance with AHRI Standard 340/360.
4. Unit shall be designed to conform to ASHRAE 15.
5. Unit shall be UL-tested and certified in accordance with ANSI Z21.47 Standards and UL-listed and certified under Canadian standards as a total package for safety requirements.
6. Insulation and adhesive shall meet NFPA 90A requirements for flame spread and smoke generation.
7. Unit casing shall be capable of withstanding 500-hour salt spray exposure per ASTM B117 (scribed specimen).
8. Unit casing shall be capable of withstanding Federal Test Method Standard No. 141 (Method 6061) 5000-hour salt spray.
9. Unit shall be designed in accordance with ISO 9001:2000, and shall be manufactured in a facility registered by ISO 9001:2000.
10. Roof curb shall be designed to conform to NRCA Standards.
11. Unit shall be subjected to a completely automated run test on the assembly line. The data for each unit will be stored at the factory, and must be available upon request.
12. Unit shall be designed in accordance with UL Standard 1995, including tested to withstand rain.
13. Unit shall be constructed to prevent intrusion of snow and tested to prevent snow intrusion into the control box up to 40 mph.
14. Unit shake tested to assurance level 1, ASTM D4169 to ensure shipping reliability.
15. High Efficient Motors listed shall meet section 313 of the Energy Independence and Security Act of 2007 (EISA 2007).

23 81 19.13.C. Delivery, Storage, and Handling

1. Unit shall be stored and handled per manufacturer's recommendations.
 2. Lifted by crane requires either shipping top panel or spreader bars.
 3. Unit shall only be stored or positioned in the upright position.
- 23 81 19.13.E. Project Conditions
1. As specified in the contract.
- 23 81 19.13.F. Operating Characteristics
1. Unit shall be capable of starting and running at 115°F (46°C) ambient outdoor temperature, meeting maximum load criteria of AHRI Standard 340/360 at ± 10% voltage.
 2. Compressor with standard controls shall be capable of operation down to 30°F (-1°C), ambient outdoor temperatures. Accessory winter start kit is necessary if mechanically cooling at ambient temperatures below 30°F (-1°C).
 3. Unit shall discharge supply air vertically or horizontally as shown on contract drawings.
 4. Unit shall be factory configured and ordered for vertical supply & return configurations.
 5. Unit shall be factory furnished for either vertical or horizontal configuration without the use of special conversion kits. No field conversion is possible. The supply air configuration determines the unit model number to be ordered.
- 23 81 19.13.G. Electrical Requirements
1. Main power supply voltage, phase, and frequency must match those required by the manufacturer.
- 23 81 19.13.H. Unit Cabinet
1. Unit cabinet shall be constructed of galvanized steel, and shall be bonderized and coated with a pre-painted baked enamel finish on all externally exposed surfaces.
 2. Unit cabinet exterior paint shall be: film thickness, (dry) 0.003 inches minimum, gloss (per ASTM D523, 60°F / 16°C): 60, Hardness: H-2H Pencil hardness.
 3. Evaporator fan compartment interior cabinet insulation shall conform to AHRI Standard 340/360 minimum exterior sweat criteria. Interior surfaces shall be insulated with a minimum 1/2-in. thick, 1 lb density, flexible fiberglass insulation, neoprene coated on the air side. Aluminum foil-faced fiberglass insulation shall be used in the gas heat compartment.
 4. Base of unit shall have a minimum of four locations for thru-the-base gas and electrical connections standard. Both gas and electric connections shall be internal to the cabinet to protect from environmental issues.
 5. Base Rail
 - a. Unit shall have base rails on a minimum of 2 sides.
 - b. Holes shall be provided in the base rails for rigging shackles to facilitate maneuvering and overhead rigging.
 - c. Holes shall be provided in the base rail for moving the rooftop by fork truck.
 - d. Base rail shall be a minimum of 16 gauge thickness.
 6. Condensate pan and connections:
 - a. Shall be a sloped condensate drain pan made of a non-corrosive material.
 - b. Shall comply with ASHRAE Standard 62.
 - c. Shall use a 3/4-in -14 NPT drain connection, through the side of the drain pan. Connection shall be made per manufacturer's recommendations.
 7. Top panel:
 - a. Shall be a multi-piece top panel linked with water tight flanges and locking systems.
 8. Gas Connections:
 - a. All gas piping connecting to unit gas valve shall enter the unit cabinet at a single location on side of unit (horizontal plane).
 - b. Thru-the-base capability
 - (1.) Standard unit shall have a thru-the-base gas-line location using a raised, embossed portion of the unit basepan.
 - (2.) Optional, factory-approved, water-tight connection method must be used for thru-the-base gas connections.
 - (3.) No basepan penetration, other than those authorized by the manufacturer, is permitted.
 9. Electrical Connections
 - a. All unit power wiring shall enter unit cabinet at a single, factory-prepared, knockout location.
 - b. Thru-the-base capability.
 - (1.) Standard unit shall have a thru-the-base electrical location(s) using a raised, embossed portion of the unit basepan.
 - (2.) Optional, factory-approved, water-tight connection method must be used for thru-the-base electrical connections.
 - (3.) No basepan penetration, other than those authorized by the manufacturer, is permitted.

10. Component access panels (standard)

- a. Cabinet panels shall be easily removable for servicing.
- b. Unit shall have one factory installed, tool-less, removable, filter access panel.
- c. Panels covering control box and filter shall have molded composite handles while the blower access door shall have an integrated flange for easy removal.
- d. Handles shall be UV modified, composite. They shall be permanently attached, and recessed into the panel.
- e. Screws on the vertical portion of all removable access panels shall engage into heat resistant, molded composite collars.
- f. Collars shall be removable and easily replaceable using manufacturer recommended parts.

23 81 19.13.I. Gas Heat

1. General

- a. Heat exchanger shall be an induced draft design. Positive pressure heat exchanger designs shall not be allowed.
- b. Shall incorporate a direct-spark ignition system and redundant main gas valve.
- c. Gas supply pressure at the inlet to the rooftop unit gas valve must match that required by the manufacturer.

2. The heat exchanger shall be controlled by an integrated gas controller (IGC) microprocessor.

- a. IGC board shall notify users of fault using an LED (light-emitting diode).
- b. The LED shall be visible without removing the control box access panel.
- c. IGC board shall contain algorithms that modify evaporator-fan operation to prevent future cycling on high temperature limit switch.
- d. Unit shall be equipped with anti-cycle protection with one short cycle on unit flame rollout switch or 4 continuous short cycles on the high temperature limit switch. Fault indication shall be made using an LED.

3. Standard Heat Exchanger construction

- a. Heat exchanger shall be of the tubular-section type constructed of a minimum of 20-gauge steel coated with a nominal 1.2 mil aluminum-silicone alloy for corrosion resistance.
- b. Burners shall be of the in-shot type constructed of aluminum-coated steel.
- c. Burners shall incorporate orifices for rated heat output up to 2000 ft (610m) elevation. Additional accessory kits may be required for applications above 2000 ft (610m) elevation, depending on local gas supply conditions.
- d. Each heat exchanger tube shall contain multiple dimples for increased heating effectiveness.

4. Optional Stainless Steel Heat Exchanger construction

- a. Use energy saving, direct-spark ignition system.
- b. Use a redundant main gas valve.
- c. Burners shall be of the in-shot type constructed of aluminum-coated steel.
- d. All gas piping shall enter the unit cabinet at a single location on side of unit (horizontal plane).
- e. The optional stainless steel heat exchanger shall be of the tubular-section type, constructed of a minimum of 20-gauge type 409 stainless steel.
- f. Type 409 stainless steel shall be used in heat exchanger tubes and vestibule plate.
- g. Complete stainless steel heat exchanger allows for greater application flexibility.

5. Induced draft combustion motor and blower

- a. Shall be a direct-drive, single inlet, forward-curved centrifugal type.
- b. Shall be made from steel with a corrosion-resistant finish.
- c. Shall have permanently lubricated sealed bearings.
- d. Shall have inherent thermal overload protection.
- e. Shall have an automatic reset feature.

23 81 19.13.J. Coils

1. Standard Coils:

- a. Standard evaporator coils shall have aluminum lanced plate fins mechanically bonded to seamless internally grooved copper tubes with all joints brazed.
- b. Evaporator coils shall be leak tested to 150 psig, pressure tested to 450 psig, and qualified to UL 1995 burst test at 1775 psig.
- c. Condenser coils shall be leak tested to 150 psig, pressure tested to 650 psig, and qualified to UL 1995 burst test at 1980 psig.

2. Optional E-coated aluminum-fin condenser coils:

- a. Shall have a flexible epoxy polymer coating uniformly applied to all coil surface areas without material bridging between fins.
- b. Coating process shall ensure complete coil encapsulation of tubes, fins and headers.
- c. Color shall be high gloss black with gloss per ASTM D523–89.
- d. Uniform dry film thickness from 0.8 to 1.2 mil on all surface areas including fin edges.
- e. Superior hardness characteristics of 2H per ASTM D3363–92A and cross-hatch adhesion of 4B–5B per ASTM D3359–93.
- f. Impact resistance shall be up to 160 in.-lb (ASTM D2794–93).
- g. Humidity and water immersion resistance shall be up to minimum 1000 and 250 hours respectively (ASTM D2247–92 and ASTM D870–92).
- h. Corrosion durability shall be confirmed through testing to be no less than 1000 hours salt spray per ASTM B117–90.

23 81 19.13.K. Refrigerant Components

1. Refrigerant circuit shall include the following control, safety, and maintenance features:
 - a. Fixed orifice metering system shall prevent mal-distribution of two-phase refrigerant by including multiple fixed orifice devices in each refrigeration circuit. Each orifice is to be optimized to the coil circuit it serves.
 - b. Refrigerant filter drier – Solid core design.
 - c. Service gauge connections on suction and discharge lines.
 - d. Pressure gauge access through a specially designed access screen on the side of the unit.
2. Compressors
 - a. Unit shall use fully hermetic, scroll compressor for each independent refrigeration circuit.
 - b. Models shall be available with 2 compressor/2 stage cooling and microchannel condenser coils.
 - c. Compressor motors shall be cooled by refrigerant gas passing through motor windings.
 - d. Compressors shall be internally protected from high discharge temperature conditions.
 - e. Compressors shall be protected from an over-temperature and over-ampereage conditions by an internal, motor overload device.
 - f. Compressor shall be factory mounted on rubber grommets.
 - g. Compressor motors shall have internal line break thermal, current overload and high pressure differential protection.
 - h. Crankcase heaters shall not be required for normal operating range, unless provided by the factory.

23 81 19.13.L. Filter Section

1. Filters access is specified in the unit cabinet section of this specification.
2. Filters shall be held in place by a preformed, slide-out filter tray, facilitating easy removal and installation.
3. Shall consist of factory-installed, low velocity, throw-away 2-in. thick fiberglass filters.
4. Filters shall be standard, commercially available sizes.
5. Only one size filter per unit is allowed.
6. 4-in filter capability is possible with a field installed pre engineered slide out filter track accessory. 4-in filters are field furnished.

23 81 19.13.M. Evaporator Fan and Motor

1. Evaporator fan motor:
 - a. Shall have inherent automatic-reset thermal overload protection or circuit breaker.
 - b. Shall have a maximum continuous bhp rating for continuous duty operation; no safety factors above that rating shall be required.
2. Belt-driven Evaporator Fan:
 - a. Belt drive shall include an adjustable-pitch motor pulley and belt break protection system.
 - b. Shall use rigid pillow block bearing system with lubricant fittings at accessible bearing or lubrication line.
 - c. Blower fan shall be double-inlet type with forward-curved blades.
 - d. Shall be constructed from steel with a corrosion resistant finish and dynamically balanced.

23 81 19.13.N. Condenser Fans and Motors

1. Condenser fan motors:
 - a. Shall be a totally enclosed motor.
 - b. Shall use permanently lubricated bearings.
 - c. Shall have inherent thermal overload protection with an automatic reset feature.
 - d. Shall use a shaft-down design.
2. Condenser Fans:

- a. Shall be a direct-driven propeller type fan.
- b. Shall have aluminum blades riveted to corrosion-resistant steel spiders and shall be dynamically balanced.

23 81 19.13.O. Special Features Options and Accessories

1. 2-Speed VFD drive motor system for 2-stage cooling models only:
 - a. Evaporator fan motor:
 - (1.) Shall have permanently lubricated bearings.
 - (2.) Shall have a maximum continuous bhp rating for continuous duty operation; no safety factors above that rating.
 - (3.) Shall be Variable Frequency duty and 2-speed control.
 - (4.) Shall contain motor shaft grounding ring to prevent electrical bearing fluting damage by safely diverting harmful shaft voltages and bearing currents to ground.
2. Variable Frequency Drive (VFD). Only available on 2-speed indoor fan motor option:
 - a. Shall be installed inside the unit cabinet, mounted, wired and tested.
 - b. Shall contain Electromagnetic Interference (EMI) frequency protection.
 - c. Insulated Gate Bi-Polar Transistors (IGBT) used to produce the output pulse width modulated (PWM) waveform, allowing for quiet motor operation.
 - d. Self diagnostics with fault and power code LED indicator. Field accessory Display Kit available for further diagnostics and special setup applications.
 - e. RS485 capability standard.
 - f. Electronic thermal overload protection.
 - g. 5% swinging chokes for harmonic reduction and improved power factor.
 - h. All printed circuit boards shall be conformal coated.
3. Integrated Economizers:
 - a. Integrated, gear-driven parallel modulating blade design type capable of simultaneous economizer and compressor operation.
 - b. Independent modules for vertical or horizontal return configurations shall be available. Vertical and horizontal return modules shall be available as a factory installed option.
 - c. Damper blades shall be galvanized steel with composite gears. Plastic or composite blades on intake or return shall not be acceptable.
 - d. Shall include all hardware and controls to provide free cooling with outdoor air when temperature and/or humidity are below setpoints.
 - e. Shall be equipped with gear driven dampers for both the outdoor ventilation air and the return air for positive air stream control.
 - f. Shall be equipped with low-leakage dampers, not to exceed 2% leakage at 1 in. wg pressure differential.
- g. Ultra low leak Economizer X system shall be available on models with 2-speed Variable Frequency Drive (VFD) systems. Only available on 2-speed indoor fan motors with electromechanical controls or RTU Open.
 - (1.) Maximum damper leakage rate to be equal to or less than 4.0 cfm/sq. ft. at 1.0 in. w.g., meeting or exceeding ASHRAE 90.1 requirements. Economizer controller on electromechanical units shall be Honeywell W7220 that provides:
 - (2.) 2-line LCD interface screen for setup, configuration and troubleshooting.
 - (3.) On-board fault detection and diagnostics
 - (4.) Sensor failure loss of communication identification
 - (5.) Automatic sensor detection
 - (6.) Capabilities for use with multiple-speed indoor fan systems
 - (7.) Utilize digital sensors: Dry bulb and Enthalpy
- h. Shall be capable of introducing up to 100% outdoor air.
 - i. Shall be equipped with a barometric relief damper capable of relieving up to 100% return air.
 - j. Shall be designed to close damper(s) during loss-of-power situations with spring return built into motor.
 - k. Dry bulb outdoor-air temperature sensor shall be provided as standard. Outdoor air sensor setpoint shall be adjustable and shall range from 40 to 100°F / 4 to 38°C. Additional sensor options shall be available as accessories.
 - l. The economizer controller shall also provide control of an accessory power exhaust unit function. Factory set at 100%, with a range of 0% to 100%.
 - m. The economizer shall maintain minimum airflow into the building during occupied period and provide design ventilation rate for full occupancy. A remote potentiometer may be used to override the damper setpoint.
 - n. Dampers shall be completely closed when the unit is in the unoccupied mode.

- o. Economizer controller shall accept a 2–10Vdc CO₂ sensor input for IAQ/DCV control. In this mode, dampers shall modulate the outdoor–air damper to provide ventilation based on the sensor input.
 - p. Compressor lockout sensor shall open at 35°F (2°C) and close closes at 50°F (10°C).
 - q. Actuator shall be direct coupled to economizer gear. No linkage arms or control rods shall be acceptable.
 - r. Economizer controller shall provide indications when in free cooling mode, in the DCV mode, or the exhaust fan contact is closed.
4. Two–Position Motorized Damper
 - a. Damper shall be a Two–Position Damper. Damper travel shall be from the full closed position to the field adjustable %–open setpoint.
 - b. Damper shall include adjustable damper travel from 25% to 100% (full open).
 - c. Damper shall include single or dual blade, gear driven dampers and actuator motor.
 - d. Actuator shall be direct coupled to damper gear. No linkage arms or control rods shall be acceptable.
 - e. Damper will admit up to 100% outdoor air for applicable rooftop units.
 - f. Damper shall close upon indoor (evaporator) fan shutoff and/or loss of power.
 - g. The damper actuator shall plug into the rooftop unit’s wiring harness plug. No hard wiring shall be required.
 - h. Outside air hood shall include aluminum water entrainment filter.
 5. Manual damper
 - a. Manual damper package shall consist of damper, air inlet screen, and rain hood which can be preset to admit up to 25% outdoor air for year round ventilation.
 6. Head Pressure Control Package
 - a. Controller shall control coil head pressure by condenser–fan speed modulation or condenser–fan cycling and wind baffles.
 - b. Shall consist of solid–state control and condenser–coil temperature sensor to maintain condensing temperature between 90°F (32°C) and 110°F (43°C)at outdoor ambient temperatures down to –20°F (–29°C).
 7. Propane Conversion Kit
 - a. Package shall contain all the necessary hardware and instructions to convert a standard natural gas unit for use with liquefied propane. Kits shall be available for elevations from 0 up to 14,000 ft (4,276m).
 8. Condenser Coil Hail Guard Assembly
 - a. Shall protect against damage from hail.
 - b. Shall be louvered style design.
 9. Unit–Mounted, Non–Fused Disconnect Switch:
 - a. Switch shall be factory–installed, internally mounted.
 - b. National Electric Code (NEC) and UL approved non–fused switch shall provide unit power shutoff.
 - c. Shall be accessible from outside the unit.
 - d. Shall provide local shutdown and lockout capability.
 10. Convenience Outlet:
 - e. Non–Powered convenience outlet.
 - (1.) Outlet shall be powered from a separate 115/120v power source.
 - (2.) A transformer shall not be included.
 - (3.) Outlet shall be factory–installed and internally mounted with easily accessible 115–v female receptacle.
 - (4.) Outlet shall include 15 amp GFI receptacles with independent fuse protection.
 - (5.) Outlet shall be accessible from outside the unit.
 11. Flue Discharge Deflector:
 - a. Flue discharge deflector shall direct unit exhaust vertically instead of horizontally.
 - b. Deflector shall be defined as a “natural draft” device by the National Fuel and Gas (NFG) code.
 12. Centrifugal Propeller Power Exhaust:
 - a. Power exhaust shall be used in conjunction with an integrated economizer.
 - b. Independent modules for vertical or horizontal return configurations shall be available.
 - c. Horizontal power exhaust is shall be mounted in return ductwork.
 - d. Power exhaust shall be controlled by economizer controller operation. Exhaust fans shall be energized when dampers open past the 0–100% adjustable setpoint on the economizer control.
 13. Roof Curbs (Vertical):
 - a. Full perimeter roof curb with exhaust capability providing separate air streams for energy recovery from the exhaust air without supply air contamination.
 - b. Formed galvanized steel with wood nailer strip and shall be capable of supporting entire unit weight.

- c. Permits installation and securing of ductwork to curb prior to mounting unit on the curb.
- 14. High Altitude Gas Conversion Kit:
 - a. Package shall contain all the necessary hardware and instructions to convert a standard natural gas unit to operate from 3,000–10,000 ft (914 to 3048m) elevation and 10,001–14,000 ft (3049–4267m) elevation.
- 15. Outdoor Air Enthalpy Sensor:
 - a. The outdoor air enthalpy sensor shall be used to provide single enthalpy control. When used in conjunction with a return air enthalpy sensor, the unit will provide differential enthalpy control. The sensor allows the unit to determine if outside air is suitable for free cooling.
- 16. Return Air Enthalpy Sensor:
 - a. The return air enthalpy sensor shall be used in conjunction with an outdoor air enthalpy sensor to provide differential enthalpy control.
- 17. Indoor Air Quality (CO₂) Sensor:
 - a. Shall be able to provide demand ventilation indoor air quality (IAQ) control.
 - b. The IAQ sensor shall be available in duct mount. The setpoint shall have adjustment capability.
- 18. Smoke detectors (Supply):
 - a. Shall be a Four–Wire Controller and Detector.
 - b. Shall be environmental compensated with differential sensing for reliable, stable, and drift–free sensitivity.
 - c. Shall use magnet–activated test/reset sensor switches.
 - d. Shall have tool–less connection terminal access.
 - e. Shall have a recessed momentary switch for testing and resetting the detector.
 - f. Controller shall include:
 - (1.) One set of normally open alarm initiation contacts for connection to an initiating device circuit on a fire alarm control panel.
 - (2.) Two Form–C auxiliary alarm relays for interface with rooftop unit or other equipment.
 - (3.) One Form–C supervision (trouble) relay to control the operation of the Trouble LED on a remote test/reset station.
 - (4.) Capable of direct connection to two individual detector modules.
 - (5.) Can be wired to up to 14 other duct smoke detectors for multiple fan shutdown applications
- 19. Winter start kit
 - a. Shall contain a bypass device around the low pressure switch.
 - b. Shall be required when mechanical cooling is required down to 25°F (–4°C).
 - c. Shall not be required to operate on an economizer when below an outdoor ambient of 40°F (4°C).
- 20. Time Guard
 - a. Shall prevent compressor short cycling by providing a 5–minute delay (±2 minutes) before restarting a compressor after shutdown for any reason.
 - b. One device shall be required per compressor.
- 21. Barometric Hood (Horizontal Economizer Applications)
 - a. Shall be required when a horizontal economizer and barometric relief are required. Barometric relief damper must be installed in the return air (horizontal) duct work. This hood provides weather protection.
- 22. Hinged Access Panels
 - a. Shall provide easy access through integrated quarter turn latches.
 - b. Shall be on major panels of; filter, control box, fan motor and compressor.
- 23. Display Kit for Variable Frequency Drive
 - a. Kit allows the ability to access the VFD controller programs to provide special setup capabilities and diagnostics.
 - b. Kit contains display module, mounting bracket and communication cable.
 - c. Display Kit can be permanently installed in the unit or used on any SAV system VFD controller as needed.