



### 14 SEER, 12 EER, PACKAGE GAS / ELECTRIC UNIT, 2.5 to 5 TONS

208/230-3-60, 460-3-60



#### REFRIGERATION CIRCUIT

- Environmentally sound R-410A refrigerant
- Copper tube/aluminum fin condenser and evaporator coils
- Scroll compressor standard on all models
- Dehumidification mode (airflow reduction) on all models

#### EASY TO INSTALL AND SERVICE

- Installs easily on a rooftop or at ground level
- Easy three-panel accessibility for maintenance and installation
- Easily converts to down discharge applications
- Combination gas heating and electric cooling
- Low NOx units available

#### BUILT TO LAST

- Hail guard (3/8" spacing) wire grilles standard on all models
- Induced-draft combustion and venting
- Pre-painted steel cabinet
- Direct spark ignition
- High efficiency ECM indoor blower motor on all models
- Aluminized steel tubular heat exchanger on PGD4 models;  
Stainless Steel tubular heat exchanger on PGS4 models
- Vertical condenser fan discharge
- Full perimeter steel base rails
- High and low pressure switches provide added reliability for the compressor

#### WARRANTY

- 10 year heat exchanger limited warranty
- 5 year compressor limited warranty
- 1 year parts limited warranty



As an Energy Star® Partner, International Comfort Products has determined that this product meets the ENERGY STAR® guidelines for energy efficiency.



Use of the AHRI Certified TM Mark indicates a manufacturer's participation in the program. For verification of certification for individual products, go to [www.ahridirectory.org](http://www.ahridirectory.org).

UNIT PERFORMANCE DATA								
Aluminized Steel Heat Exchanger	Stainless Steel Heat Exchanger	COOLING			HEATING		Unit Dimensions Height x Width x Depth in (mm)	Operating Weight lbs (kg)
		Capacity BTU/h	SEER	EER	Input BTU/h	Efficiency AFUE %		
PGD430040H00°C	PGS430040HGS°C	28,600	14.5	12.0	40,000	80.0	40 x 48 <sup>3</sup> / <sub>16</sub> x 32 <sup>5</sup> / <sub>8</sub> (1016 x 1224 x 829)	342 (155)
PGD430060H00°C	PGS430060HGS°C	28,600	14.5	12.0	60,000	80.0	40 x 48 <sup>3</sup> / <sub>16</sub> x 32 <sup>5</sup> / <sub>8</sub> (1016 x 1224 x 829)	342 (155)
PGD436060°00°C	PGS436060°GS°C	34,200	14.5	12.0	60,000	80.0	46 x 48 <sup>3</sup> / <sub>16</sub> x 32 <sup>5</sup> / <sub>8</sub> (1167 x 1224 x 829)	376 (170)
PGD436090°00°C	PGS436090°GS°C	34,200	14.5	12.0	90,000	79.3	46 x 48 <sup>3</sup> / <sub>16</sub> x 32 <sup>5</sup> / <sub>8</sub> (1167 x 1224 x 829)	376 (170)
PGD442060°00°C	PGS442060°GS°C	41,000	14.5	12.0	60,000	78.5	50 x 48 <sup>3</sup> / <sub>16</sub> x 44 <sup>1</sup> / <sub>8</sub> (1267 x 1224 x 1123)	463 (210)
PGD442090°00°C	PGS442090°GS°C	41,000	14.5	12.0	90,000	80.4	50 x 48 <sup>3</sup> / <sub>16</sub> x 44 <sup>1</sup> / <sub>8</sub> (1267 x 1224 x 1123)	463 (210)
PGD448090°00°C	PGS448090°GS°C	47,000	14.2	12.0	90,000	80.4	50 x 48 <sup>3</sup> / <sub>16</sub> x 44 <sup>1</sup> / <sub>8</sub> (1267 x 1224 x 1123)	481 (218)
PGD448115°00°C	PGS448115°GS°C	47,000	14.2	12.0	115,000	80.3	50 x 48 <sup>3</sup> / <sub>16</sub> x 44 <sup>1</sup> / <sub>8</sub> (1267 x 1224 x 1123)	481 (218)
PGD448130°00°C	PGS448130°GS°C	47,000	14.2	12.0	130,000	78.9	50 x 48 <sup>3</sup> / <sub>16</sub> x 44 <sup>1</sup> / <sub>8</sub> (1267 x 1224 x 1123)	481 (218)
PGD460090°00°C	PGS460090°GS°C	57,000	14.2	12.0	90,000	80.4	54 x 48 <sup>3</sup> / <sub>16</sub> x 44 <sup>1</sup> / <sub>8</sub> (1368 x 1224 x 1123)	509 (231)
PGD460115°00°C	PGS460115°GS°C	57,000	14.2	12.0	115,000	80.3	54 x 48 <sup>3</sup> / <sub>16</sub> x 44 <sup>1</sup> / <sub>8</sub> (1368 x 1224 x 1123)	509 (231)
PGD460130°00°C	PGS460130°GS°C	57,000	14.2	12.0	130,000	78.9	54 x 48 <sup>3</sup> / <sub>16</sub> x 44 <sup>1</sup> / <sub>8</sub> (1368 x 1224 x 1123)	509 (231)

^ H = 208/230-3-60, L = 460-3-60

\* - 0 = Standard, 1 = Low NOx

MODEL NOMENCLATURE											
MODEL SERIES	1	2	3	4	5,6	7,8,9	10	11,12	13	14	15
	<b>P</b>	<b>G</b>	<b>D</b>	<b>4</b>	<b>36</b>	<b>090</b>	<b>H</b>	<b>00</b>	<b>0</b>	<b>C</b>	<b>1</b>
P = Package A = Air Conditioner H = Heat Pump G = Gas/Electric D = Dual Fuel D = Standard S = Mainline w/ SS HX											
<b>TYPE</b>											
3 = 13 4 = 14											
<b>SEER</b>											
30 = 30,000 BTUH = 2.5 Tons 36 = 36,000 BTUH = 3 Tons 42 = 42,000 BTUH = 3.5 Tons 48 = 48,000 BTUH = 4 Tons 60 = 60,000 BTUH = 5 Tons											
<b>NOMINAL COOLING CAPACITY</b>											
000 = no factory heat 040 = 40,000 BTU/hr 060 = 60,000 BTU/hr 090 = 90,000 BTU/hr 115 = 115,000 BTU/hr 130 = 130,000 BTU/hr											
<b>NOMINAL HEATING BTUH (input)</b>											
H = 208/230-3-60 L = 460-3-60											
<b>VOLTAGE</b>											
00 = No options GS = Stainless Steel Heat Exchanger											
<b>FACTORY INSTALLED OPTIONS</b>											
0 = Standard 1 = Low NOx											
<b>FEATURE CODE</b>											
Sales Model Digit											
Engineering Digit											

## AHRI\* CAPACITIES

COOLING CAPACITIES AND EFFICIENCIES					
PGD4, PGS4	NOMINAL TONS	STANDARD CFM	COOLING CAPACITY	EER	SEER
30	2.5	1000	28600	12.0	14.5
36	3	1200	34200	12.0	14.5
42	3.5	1400	41000	12.0	14.5
48	4	1600	47000	12.0	14.2
60	5	1750	57000	12.0	14.2

### LEGEND

**dB**—Sound Levels (decibels)

**db**—Dry Bulb

**SEER**—Seasonal Energy Efficiency Ratio

**wb**—Wet Bulb

**COP**—Coefficient of Performance

\* Air Conditioning, Heating, & Refrigeration Institute.

\*\*At "A" conditions—80°F (26.7°C) indoor db/67°F (19.4°C) indoor wb & 95°F (35°C) outdoor db.

† Rated in accordance with U.S. Government DOE Department of Energy) test procedures and/or AHRI Standards 210/240.

### Notes:

1. Ratings are net values, reflecting the effects of circulating fan heat.

Ratings are based on:

**Cooling Standard:** 80°F (26.7°C) db, 67°F wb (19.4°C) indoor entering—air temperature and 95°F db (35°C) outdoor entering—air temperature.

2. Before purchasing this appliance, read important energy cost and efficiency information available from your retailer.

GAS HEATING CAPACITIES AND EFFICIENCIES				
UNIT PGD4, PGS4	HEATING INPUT (Btuh)	OUTPUT CAPACITY (Btuh)	TEMPERATURE RISE RANGE °F (°C)	AFUE (%)
<b>30040</b>	40,000	32,000	30-60 (17-33)	80.0
<b>30060</b>	60,000	48,000	25-55 (14-31)	80.0
<b>36060</b>		48,000		80.0
<b>42060</b>		47,000		78.5
<b>36090</b>	90,000	72,000	35-65 (19-36)	79.3
<b>42090</b>		73,000		80.4
<b>48090</b>		73,000		80.4
<b>60090</b>		73,000		80.4
<b>48115</b>	115,000	93,000	30-60 (17-33)	80.3
<b>60115</b>				
<b>48130</b>	130,000	103,000	35-65 (19-36)	78.9
<b>60130</b>				

### LEGEND

**AFUE**—Annual Fuel Utilization Efficiency

NOTE: Before purchasing this appliance, read important energy cost and efficiency information available from your retailer.

**ELECTRICAL DATA**

UNIT	NOMINAL V-PH-HZ	VOLTAGE RANGE		COMPRESSOR			OFM	IFM	IDM	POWER SUPPLY	
PG(D,S)4030040	208/230-3-60	197	253	8.3	58.0	0.7	4.1	0.65	15.2	20	
PG(D,S)4030060				8.3	58.0	0.7	4.1	1.65	15.2	20	
PG(D,S)4036060				9.0	71.0	1.2	6.0	1.65	18.5	25	
PG(D,S)4036090				9.0	71.0	1.2	6.0	0.52	18.5	25	
PG(D,S)4042060				13.5	88.0	1.2	6.0	1.65	24.1	35	
PG(D,S)4042090				13.5	88.0	1.2	6.0	0.65	24.1	35	
PG(D,S)4048090				13.7	83.1	1.2	7.6	0.65	25.9	35	
PG(D,S)4048115				13.7	83.1	1.2	7.6	1.65	25.9	35	
PG(D,S)4048130				13.7	83.1	1.2	7.6	0.52	25.9	35	
PG(D,S)4060090				16.0	110.0	1.2	7.6	0.65	28.8	40	
PG(D,S)4060115				16.0	110.0	1.2	7.6	1.65	28.8	40	
PG(D,S)4060130				16.0	110.0	1.2	7.6	0.52	28.8	40	
PG(D,S)4036060				460-3-60	414	506	5.6	38.0	0.5	3.0	0.70
PG(D,S)4036090	5.6	38.0	0.5				3.0	0.30	10.5	15	
PG(D,S)4042060	6.0	44.0	0.5				3.0	0.70	11.0	15	
PG(D,S)4042090	6.0	44.0	0.5				3.0	0.33	11.0	15	
PG(D,S)4048090	6.2	41.0	0.5				3.8	0.33	12.1	15	
PG(D,S)4048115	6.2	41.0	0.5				3.8	0.70	12.1	15	
PG(D,S)4048130	6.2	41.0	0.5				3.8	0.30	12.1	15	
PG(D,S)4060090	7.8	52.0	0.5				3.8	0.33	14.1	20	
PG(D,S)4060115	7.8	52.0	0.5				3.8	0.70	14.1	20	
PG(D,S)4060130	7.8	52.0	0.5				3.8	0.30	14.1	20	

**LEGEND**

- FLA -- Full Load Amps
- LRA -- Locked Rotor Amps
- MCA -- Minimum Circuit Amps
- MOCP -- Maximum Overcurrent Protection
- RLA -- Rated Load Amps



EXAMPLE: Supply voltage is 230-3-60.

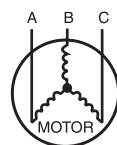

- AB = 228 v
- BC = 231 v
- AC = 227 v

$$\begin{aligned} \text{Average Voltage} &= \frac{228 + 231 + 227}{3} \\ &= \frac{686}{3} \\ &= 229 \end{aligned}$$

**NOTES:**

1. In compliance with NEC (National Electrical Code) requirements for multimotor and combination load equipment (refer to NEC Articles 430 and 440), the overcurrent protective device for the unit shall be Power Supply fuse. The CGA (Canadian Gas Association) units may be fuse or circuit breaker.
2. Minimum wire size is based on 60 C copper wire. If other than 60 C wire is used, or if length exceeds wire length in table, determine size from NEC.
3. Unbalanced 3-Phase Supply Voltage  
*Never operate a motor where a phase imbalance in supply voltage is greater than 2%.* Use the following formula to determine the percentage of voltage imbalance

% Voltage imbalance

$$= 100 \times \frac{\text{max voltage deviation from average voltage}}{\text{average voltage}}$$

Determine maximum deviation from average voltage.

- (AB) 229 - 228 = 1 v
- (BC) 231 - 229 = 2 v
- (AC) 229 - 227 = 2 v

Maximum deviation is 2 v.

Determine percent of voltage imbalance

$$\begin{aligned} \% \text{ Voltage Imbalance} &= 100 \times \frac{2}{229} \\ &= 0.8\% \end{aligned}$$

This amount of phase imbalance is satisfactory as it is below the maximum allowable 2%.

**IMPORTANT:** If the supply voltage phase imbalance is more than 2%, contact your local electric utility company immediately.

<b>PHYSICAL DATA – PGD4, PGS4</b>						
<b>UNIT SIZE</b>	<b>30040</b>	<b>30060</b>	<b>36060</b>	<b>36090</b>	<b>42060</b>	<b>42090</b>
<b>NOMINAL COOLING CAPACITY (ton)</b>	2-1/2	2-1/2	3	3	3-1/2	3-1/2
<b>NOMINAL HEATING INPUT (Btu/hrs)</b>	40,000	60,000	60,000	90,000	60,000	90,000
<b>SHIPPING WEIGHT lb.</b>	349	349	383	383	472	472
<b>SHIPPING WEIGHT (kg)</b>	158	158	174	174	214	214
<b>COMPRESSORS</b>	Scroll					
Quantity	1					
<b>REFRIGERANT (R-410A)</b>						
Quantity lb.	5.6	5.6	9.5	9.5	8.8	8.8
Quantity (kg)	2.5	2.5	4.3	4.3	4.0	4.0
<b>REFRIGERANT METERING DEVICE</b>	TXV					
<b>OUTDOOR COIL</b>						
Rows...Fins/in.	1...21	1...21	2...21	2...21	2...21	2...21
Face Area (sq ft)	13.6	13.6	15.4	15.4	13.6	13.6
<b>OUTDOOR FAN</b>						
Nominal CFM	2700	2700	2800	2800	3000	3000
Diameter in.	24	24	24	24	26	26
Diameter (mm)	609.6	609.6	609.6	609.6	660.4	660.4
Motor Hp (Rpm)	1/10 (810)	1/10 (810)	1/5 (810)	1/5 (810)	1/5 (810)	1/5 (810)
<b>INDOOR COIL</b>						
Rows...Fins/in.	3...17	3...17	3...17	3...17	3...17	3...17
Face Area (sq ft)	3.7	3.7	3.7	3.7	4.7	4.7
<b>INDOOR BLOWER</b>						
Nominal Cooling Airflow (Cfm)	1000	1000	1200	1200	1400	1400
Size in.	10x10	10x10	11x10	11x10	11x10	11x10
Size (mm.)	254x254	254x254	279.4x254	279.4x254	279.4x254	279.4x254
Motor HP (RPM)	1/2 (1050)	1/2 (1050)	3/4 (1000)	3/4 (1000)	3/4 (1075)	3/4 (1075)
<b>FURNACE SECTION*</b>						
Burner Orifice No.						
Natural Gas Qty...Drill Size (Factory Installed)	2...44	2...38	2...38	3...38	2...38	3...38
Propane Gas	2...55	2...53	2...53	3...53	2...53	3...53
<b>HIGH-PRESSURE SWITCH (psig) Cut-out Reset (Auto)</b>	650 +/- 15 420 +/- 25					
<b>LOSS-OF-CHARGE / LOW-PRESSURE SWITCH (Liquid Line) (psig) cut-out Reset (auto)</b>	20 +/- 5 45 +/- 10					
<b>RETURN-AIR FILTERS†‡</b>						
Throwaway Size in. (mm)	20x20x1 508x508x25	20x24x1 508x610x25			24x30x1 610x762x25	

PHYSICAL DATA – PGD4, PGS4 (CONT)						
<b>UNIT SIZE</b>	<b>48090</b>	<b>48115</b>	<b>48130</b>	<b>60090</b>	<b>60115</b>	<b>60130</b>
<b>NOMINAL COOLING CAPACITY (ton)</b>	4	4	4	5	5	5
<b>NOMINAL HEATING INPUT (Btu/hrs)</b>	90,000	115,000	130,000	90,000	115,000	130,000
<b>SHIPPING WEIGHT lb</b>	490	490	490	518	518	518
<b>SHIPPING WEIGHT kg</b>	222	222	222	235	235	235
<b>COMPRESSORS</b>	Scroll					
Quantity	1					
<b>REFRIGERANT (R-410A)</b>						
Quantity lb	9.5	9.5	9.5	12.3	12.3	12.3
Quantity (kg.)	4.3	4.3	4.3	5.6	5.6	5.6
<b>REFRIGERANT METERING DEVICE</b>	TXV					
<b>OUTDOOR COIL</b>						
Rows...Fins/in.	2...21	2...21	2...21	2...21	2...21	2...21
Face Area (sq ft)	17.5	17.5	17.5	21.4	21.4	21.4
<b>OUTDOOR FAN</b>						
Nominal Cfm	3200	3200	3200	3600	3600	3600
Diameter in.	26	26	26	26	26	26
Diameter (mm)	660.4	660.4	660.4	660.4	660.4	660.4
Motor Hp (Rpm)	1/5 (810)	1/5 (810)	1/5 (810)	1/5 (810)	1/5 (810)	1/5 (810)
<b>INDOOR COIL</b>						
Rows...Fins/in.	3...17	3...17	3...17	3...17	3...17	3...17
Face Area (sq ft)	4.7	4.7	4.7	5.7	5.7	5.7
<b>INDOOR BLOWER</b>						
Nominal Cooling Airflow (Cfm)	1600	1600	1600	1750	1750	1750
Size in.	11x10	11x10	11x10	11x10	11x10	11x10
Size (mm)	279.4x254	279.4x254	279.4x254	279.4x254	279.4x254	279.4x254
Motor HP (RPM)	1.0 (1075)	1.0 (1075)	1.0 (1075)	1.0 (1040)	1.0 (1040)	1.0 (1040)
<b>FURNACE SECTION* Burner Orifice No.</b>						
Natural Gas Qty...Drill Size (Factory Installed)	3...38	3...33	3...31	3...38	3...33	3...31
Propane Gas	3...53	3...51	3...49	3...53	3...51	3...49
<b>HIGH-PRESSURE SWITCH (psig) Cut-out Reset (Auto)</b>	650 +/- 15 420 +/- 25					
<b>LOSS-OF-CHARGE / LOW-PRESSURE SWITCH (Liquid Line) (psig) cut-out Reset (auto)</b>	20 +/- 5 45 +/- 10					
<b>RETURN-AIR FILTERS</b> Throwaway†‡ in. (mm)	24x36x1 610x914x25					

\*Based on altitude of 0 to 2000 ft (0–610 m).

† Required filter sizes shown are based on the larger of the AHRI (Air Conditioning, Heating, and Refrigeration Institute) rated cooling airflow or the heating airflow velocity of 300 ft/minute for throwaway type. Air filter pressure drop for non-standard filters must not exceed 0.08 IN. W.C.

‡ If using accessory filter rack refer to the filter rack installation instructions for correct filter sizes and quantity.

A-WEIGHTED SOUND POWER LEVEL (DBA)								
MODEL PGD4, PGS4	SOUND RATING	TYPICAL OCTAVE BAND SPECTRUM (without tone adjustment)						
		125	250	500	1000	2000	4000	8000
30	73	62.0	64.0	67.5	67.5	65.0	60.0	54.5
36	76	64.5	66.5	70.0	70.0	67.5	61.0	54.0
42	77	70.5	68.0	70.5	70.5	68.0	62.5	58.0
48	77	71.5	65.0	71.0	67.5	67.5	63.0	57.5
60	77	73.5	65.5	68.5	67.5	66.5	62.0	58.0

NOTE: Tested in accordance with AHRI Standard 270 (not listed in AHRI).

**DRY COIL AIR DELIVERY\* – HORIZONTAL AND DOWNFLOW DISCHARGE – UNIT PGD4/PGS4**

UNIT	HEATING RISE RANGE °F (°C)	MOTOR SPEED	WIRE COLOR		EXTERNAL STATIC PRESSURE (IN. W.C.)										
					0.1	0.2	0.3	0.4	0.5	0.6	0.7	0.8	0.9		
PG(D,S)430040	30 - 60 (17 - 33)	Low	Blue	CFM	741	638	547	415	--	--	--	--	--		
				Heating Rise (°F)	41	47	55	NA	NA	NA	NA	NA	NA		
				Heating Rise (°C)	23	26	31	NA	NA	NA	NA	NA	NA		
		Med-Low <sup>1</sup>	Pink	CFM	973	887	823	733	665	538	451	--	--		
				Heating Rise (°F)	31	34	37	41	45	56	NA	NA	NA		
				Heating Rise (°C)	17	19	20	23	25	31	NA	NA	NA		
		Medium	Red	CFM	1088	1023	954	881	800	723	658	563	461		
				Heating Rise (°F)	NA	30	32	34	38	42	46	54	NA		
				Heating Rise (°C)	NA	16	18	19	21	23	26	30	NA		
		Med-High <sup>2</sup>	Orange	CFM	1140	1064	996	915	840	758	687	564	480		
				Heating Rise (°F)	NA	NA	30	33	36	40	44	54	NA		
				Heating Rise (°C)	NA	NA	17	18	20	22	24	30	NA		
		High	Black	CFM	1202	1140	1082	1015	961	881	810	732	631		
				Heating Rise (°F)	NA	NA	NA	30	31	34	37	41	48		
				Heating Rise (°C)	NA	NA	NA	17	17	19	21	23	27		
		PG(D,S)430060	25 - 55 (14 - 31)	Low	Blue	CFM	741	638	547	415	--	--	--	--	--
						Heating Rise (°F)	NA	NA	NA	NA	NA	NA	NA	NA	NA
						Heating Rise (°C)	NA	NA	NA	NA	NA	NA	NA	NA	NA
Med-Low	Pink			CFM	973	887	823	733	665	538	451	--	--		
				Heating Rise (°F)	46	50	54	NA	NA	NA	NA	NA	NA		
				Heating Rise (°C)	25	28	30	NA	NA	NA	NA	NA	NA		
Medium	Red			CFM	1088	1023	954	881	800	723	658	563	461		
				Heating Rise (°F)	41	43	47	50	NA	NA	NA	NA	NA		
				Heating Rise (°C)	23	24	26	28	NA	NA	NA	NA	NA		
Med-High <sup>2</sup>	Orange			CFM	1140	1064	996	915	840	758	687	564	480		
				Heating Rise (°F)	39	42	45	49	53	NA	NA	NA	NA		
				Heating Rise (°C)	22	23	25	27	29	NA	NA	NA	NA		
High <sup>1</sup>	Black			CFM	1202	1140	1082	1015	961	881	810	732	631		
				Heating Rise (°F)	37	39	41	44	46	50	55	NA	NA		
				Heating Rise (°C)	21	22	23	24	26	28	30	NA	NA		
PG(D,S)436060	25 - 55 (14 - 31)			Low <sup>1</sup>	Blue	CFM	1234	1168	1093	1021	961	894	825	759	687
						Heating Rise (°F)	36	38	41	44	46	50	54	NA	NA
						Heating Rise (°C)	20	21	23	24	26	28	30	NA	NA
		Med-Low	Pink	CFM	1290	1223	1154	1090	1027	977	894	828	762		
				Heating Rise (°F)	34	36	39	41	43	45	50	54	NA		
				Heating Rise (°C)	19	20	21	23	24	25	28	30	NA		
		Medium <sup>2</sup>	Red	CFM	1354	1290	1226	1158	1102	1046	981	918	843		
				Heating Rise (°F)	33	34	36	38	40	42	45	48	53		
				Heating Rise (°C)	18	19	20	21	22	24	25	27	29		
		Med-High	Orange	CFM	1606	1546	1489	1430	1371	1316	1258	1208	1140		
				Heating Rise (°F)	28	29	30	31	32	34	35	37	39		
				Heating Rise (°C)	15	16	17	17	18	19	20	20	22		
		High	Black	CFM	1630	1580	1517	1463	1407	1339	1277	1210	1131		
				Heating Rise (°F)	27	28	29	30	32	33	35	37	39		
				Heating Rise (°C)	15	16	16	17	18	18	19	20	22		
		PG(D,S)436090	35 - 65 (19 - 36)	Low	Blue	CFM	1234	1168	1093	1021	961	894	825	759	687
						Heating Rise (°F)	55	58	62	NA	NA	NA	NA	NA	NA
						Heating Rise (°C)	31	32	35	NA	NA	NA	NA	NA	NA
Med-Low	Pink			CFM	1290	1223	1154	1090	1027	977	894	828	762		
				Heating Rise (°F)	53	56	59	62	NA	NA	NA	NA	NA		
				Heating Rise (°C)	29	31	33	35	NA	NA	NA	NA	NA		
Medium <sup>2</sup>	Red			CFM	1354	1290	1226	1158	1102	1046	981	918	843		
				Heating Rise (°F)	50	53	55	59	62	65	NA	NA	NA		
				Heating Rise (°C)	28	29	31	33	34	36	NA	NA	NA		
Med-High	Orange			CFM	1606	1546	1489	1430	1371	1316	1258	1208	1140		
				Heating Rise (°F)	42	44	46	48	50	52	54	56	60		
				Heating Rise (°C)	24	24	25	26	28	29	30	31	33		
High <sup>1</sup>	Black			CFM	1630	1580	1517	1463	1407	1339	1277	1210	1131		
				Heating Rise (°F)	42	43	45	46	48	51	53	56	60		
				Heating Rise (°C)	23	24	25	26	27	28	30	31	33		

**DRY COIL AIR DELIVERY\* – HORIZONTAL AND DOWNFLOW DISCHARGE – UNIT PGD4/PGS4 (CONT)**

UNIT	HEATING RISE RANGE °F (°C)	MOTOR SPEED	WIRE COLOR	EXTERNAL STATIC PRESSURE (IN. W.C.)									
				0.1	0.2	0.3	0.4	0.5	0.6	0.7	0.8	0.9	
PG(D,S)442060	25 - 55 (14 - 31)	Low <sup>1</sup>	Blue	CFM	1295	1234	1182	1126	1075	1016	955	898	857
				Heating Rise (°F)	34	36	38	39	41	44	47	49	52
				Heating Rise (°C)	19	20	21	22	23	24	26	27	29
		Med-Low	Pink	CFM	1345	1282	1235	1194	1140	1095	1027	974	921
				Heating Rise (°F)	33	35	36	37	39	41	43	46	48
				Heating Rise (°C)	18	19	20	21	22	23	24	25	27
		Medium	Red	CFM	1505	1452	1413	1358	1323	1282	1234	1169	1130
				Heating Rise (°F)	30	31	31	33	34	35	36	38	39
				Heating Rise (°C)	16	17	17	18	19	19	20	21	22
		Med-High <sup>2</sup>	Orange	CFM	1545	1492	1449	1411	1362	1313	1278	1231	1188
				Heating Rise (°F)	29	30	31	31	33	34	35	36	37
				Heating Rise (°C)	16	17	17	17	18	19	19	20	21
		High	Black	CFM	1705	1643	1607	1568	1518	1483	1448	1404	1360
				Heating Rise (°F)	26	27	28	28	29	30	31	32	33
				Heating Rise (°C)	14	15	15	16	16	17	17	18	18
PG(D,S)442090	35 - 65 (19 - 36)	Low	Blue	CFM	1295	1234	1182	1126	1075	1016	955	898	857
				Heating Rise (°F)	53	55	58	60	63	NA	NA	NA	NA
				Heating Rise (°C)	29	31	32	34	35	NA	NA	NA	NA
		Med-Low	Pink	CFM	1345	1282	1235	1194	1140	1095	1027	974	921
				Heating Rise (°F)	51	53	55	57	60	62	NA	NA	NA
				Heating Rise (°C)	28	29	31	32	33	35	NA	NA	NA
		Medium <sup>1</sup>	Red	CFM	1505	1452	1413	1358	1323	1282	1234	1169	1130
				Heating Rise (°F)	45	47	48	50	51	53	55	58	60
				Heating Rise (°C)	25	26	27	28	29	29	31	32	33
		Med-High <sup>2</sup>	Orange	CFM	1545	1492	1449	1411	1362	1313	1278	1231	1188
				Heating Rise (°F)	44	46	47	48	50	52	53	55	57
				Heating Rise (°C)	24	25	26	27	28	29	30	31	32
		High	Black	CFM	1705	1643	1607	1568	1518	1483	1448	1404	1360
				Heating Rise (°F)	40	41	42	43	45	46	47	48	50
				Heating Rise (°C)	22	23	24	24	25	25	26	27	28
PG(D,S)448090	35 - 65 (19 - 36)	Low <sup>1</sup>	Blue	CFM	1402	1351	1311	1263	1224	1172	1136	1080	1041
				Heating Rise (°F)	49	50	52	54	56	58	60	63	65
				Heating Rise (°C)	27	28	29	30	31	32	33	35	36
		Med-Low	Pink	CFM	1457	1404	1367	1318	1284	1233	1197	1144	1104
				Heating Rise (°F)	47	48	50	52	53	55	57	59	62
				Heating Rise (°C)	26	27	28	29	29	31	32	33	34
		Medium <sup>2</sup>	Red	CFM	1736	1695	1642	1601	1553	1512	1465	1427	1381
				Heating Rise (°F)	39	40	41	42	44	45	46	48	49
				Heating Rise (°C)	22	22	23	24	24	25	26	26	27
		Med-High	Orange	CFM	2149	2111	2062	2026	1980	1945	1905	1864	1793
				Heating Rise (°F)	NA	NA	NA	NA	NA	35	36	36	38
				Heating Rise (°C)	NA	NA	NA	NA	NA	19	20	20	21
		High	Black	CFM	2344	2306	2259	2203	2141	2070	1991	1902	1803
				Heating Rise (°F)	NA	NA	NA	NA	NA	NA	NA	36	38
				Heating Rise (°C)	NA	NA	NA	NA	NA	NA	NA	20	21
PG(D,S)448115	30 - 60 (17 - 33)	Low	Blue	CFM	1402	1351	1311	1263	1224	1172	1136	1080	1041
				Heating Rise (°F)	NA	NA	NA	NA	NA	NA	NA	NA	NA
				Heating Rise (°C)	NA	NA	NA	NA	NA	NA	NA	NA	NA
		Med-Low	Pink	CFM	1457	1404	1367	1318	1284	1233	1197	1144	1104
				Heating Rise (°F)	60	NA	NA	NA	NA	NA	NA	NA	NA
				Heating Rise (°C)	33	NA	NA	NA	NA	NA	NA	NA	NA
		Medium <sup>2</sup>	Red	CFM	1736	1695	1642	1601	1553	1512	1465	1427	1381
				Heating Rise (°F)	50	51	53	54	56	57	59	NA	NA
				Heating Rise (°C)	28	28	29	30	31	32	33	NA	NA
		Med-High <sup>1</sup>	Orange	CFM	2149	2111	2062	2026	1980	1945	1905	1864	1793
				Heating Rise (°F)	40	41	42	43	44	45	46	47	48
				Heating Rise (°C)	22	23	23	24	24	25	25	26	27
		High	Black	CFM	2344	2306	2259	2203	2141	2070	1991	1902	1803
				Heating Rise (°F)	37	38	38	39	41	42	44	46	48
				Heating Rise (°C)	21	21	21	22	23	23	24	25	27
PG(D,S)448130	35 - 65 (19 - 36)	Low	Blue	CFM	1402	1351	1311	1263	1224	1172	1136	1080	1041
				Heating Rise (°F)	NA	NA	NA	NA	NA	NA	NA	NA	NA
				Heating Rise (°C)	NA	NA	NA	NA	NA	NA	NA	NA	NA
		Med-Low	Pink	CFM	1457	1404	1367	1318	1284	1233	1197	1144	1104
				Heating Rise (°F)	NA	NA	NA	NA	NA	NA	NA	NA	NA
				Heating Rise (°C)	NA	NA	NA	NA	NA	NA	NA	NA	NA
		Medium <sup>2</sup>	Red	CFM	1736	1695	1642	1601	1553	1512	1465	1427	1381
				Heating Rise (°F)	55	57	59	60	62	64	NA	NA	NA
				Heating Rise (°C)	31	32	33	33	34	35	NA	NA	NA
		Med-High <sup>1</sup>	Orange	CFM	2149	2111	2062	2026	1980	1945	1905	1864	1793
				Heating Rise (°F)	45	46	47	48	49	50	51	52	54
				Heating Rise (°C)	25	25	26	26	27	28	28	29	30
		High	Black	CFM	2344	2306	2259	2203	2141	2070	1991	1902	1803
				Heating Rise (°F)	41	42	43	44	45	47	48	51	53
				Heating Rise (°C)	23	23	24	24	25	26	27	28	30

**DRY COIL AIR DELIVERY\* – HORIZONTAL AND DOWNFLOW DISCHARGE – UNIT PGD4/PGS4 (CONT)**

UNIT	HEATING RISE RANGE °F (°C)	MOTOR SPEED	WIRE COLOR		EXTERNAL STATIC PRESSURE (IN. W.C.)								
					0.1	0.2	0.3	0.4	0.5	0.6	0.7	0.8	0.9
PG(D,S)460090	35 - 65 (19 - 36)	Low <sup>1</sup>	Blue	CFM	1445	1389	1341	1281	1236	1189	1139	1072	1027
				Heating Rise (°F)	47	49	51	53	55	57	60	63	NA
				Heating Rise (°C)	26	27	28	29	31	32	33	35	NA
		Med-Low	Pink	CFM	1678	1635	1602	1558	1513	1474	1438	1404	1349
				Heating Rise (°F)	41	42	42	44	45	46	47	48	50
				Heating Rise (°C)	23	23	24	24	25	26	26	27	28
		Medium <sub>2</sub>	Red	CFM	1962	1915	1880	1843	1794	1753	1711	1675	1628
				Heating Rise (°F)	35	36	36	37	38	39	40	41	42
				Heating Rise (°C)	19	20	20	20	21	22	22	23	23
		Med-High	Orange	CFM	2131	2088	2065	2013	1982	1941	1888	1860	1785
				Heating Rise (°F)	NA	NA	NA	NA	NA	35	36	37	38
				Heating Rise (°C)	NA	NA	NA	NA	NA	19	20	20	21
		High	Black	CFM	2461	2409	2339	2286	2192	2140	2062	1968	1874
				Heating Rise (°F)	NA	NA	NA	NA	NA	NA	NA	35	36
				Heating Rise (°C)	NA	NA	NA	NA	NA	NA	NA	19	20
PG(D,S)460115	30 - 60 (17 - 33)	Low	Blue	CFM	1445	1389	1341	1281	1236	1189	1139	1072	1027
				Heating Rise (°F)	60	NA	NA	NA	NA	NA	NA	NA	NA
				Heating Rise (°C)	33	NA	NA	NA	NA	NA	NA	NA	NA
		Med-Low	Pink	CFM	1678	1635	1602	1558	1513	1474	1438	1404	1349
				Heating Rise (°F)	52	53	54	56	57	59	60	NA	NA
				Heating Rise (°C)	29	30	30	31	32	33	34	NA	NA
		Medium <sub>2</sub>	Red	CFM	1962	1915	1880	1843	1794	1753	1711	1675	1628
				Heating Rise (°F)	44	45	46	47	48	50	51	52	53
				Heating Rise (°C)	25	25	26	26	27	28	28	29	30
		Med-High <sup>1</sup>	Orange	CFM	2131	2088	2065	2013	1982	1941	1888	1860	1785
				Heating Rise (°F)	41	42	42	43	44	45	46	47	49
				Heating Rise (°C)	23	23	23	24	24	25	26	26	27
		High	Black	CFM	2461	2409	2339	2286	2192	2140	2062	1968	1874
				Heating Rise (°F)	35	36	37	38	40	41	42	44	46
				Heating Rise (°C)	20	20	21	21	22	23	23	25	26
PG(D,S)460130	35 - 65 (19 - 36)	Low	Blue	CFM	1445	1389	1341	1281	1236	1189	1139	1072	1027
				Heating Rise (°F)	NA	NA	NA	NA	NA	NA	NA	NA	NA
				Heating Rise (°C)	NA	NA	NA	NA	NA	NA	NA	NA	NA
		Med-Low	Pink	CFM	1678	1635	1602	1558	1513	1474	1438	1404	1349
				Heating Rise (°F)	57	59	60	62	64	65	NA	NA	NA
				Heating Rise (°C)	32	33	33	34	35	36	NA	NA	NA
		Medium <sub>2</sub>	Red	CFM	1962	1915	1880	1843	1794	1753	1711	1675	1628
				Heating Rise (°F)	49	50	51	52	54	55	56	57	59
				Heating Rise (°C)	27	28	28	29	30	31	31	32	33
		Med-High <sup>1</sup>	Orange	CFM	2131	2088	2065	2013	1982	1941	1888	1860	1785
				Heating Rise (°F)	45	46	47	48	49	50	51	52	54
				Heating Rise (°C)	25	26	26	27	27	28	28	29	30
		High	Black	CFM	2461	2409	2339	2286	2192	2140	2062	1968	1874
				Heating Rise (°F)	39	40	41	42	44	45	47	49	51
				Heating Rise (°C)	22	22	23	23	24	25	26	27	29

\*Air delivery values are without air filter and are for dry coil (See PGD4/PGS4-A Wet Coil Pressure Drop table).

<sup>1</sup> Factory-shipped heating speed

<sup>2</sup> Factory-shipped cooling speed

"NA" = Not allowed for heating speed

Note: For horizontal applications deduct field-supplied air filter pressure drop and wet coil pressure drop to obtain external static pressure available for ducting.

For downflow applications see Wet Coil Air Delivery table for available static including wet coil, 1-in. filter and economizer.

Shaded areas indicate speed/static combinations that are not permitted for dehumidification speed.

### HORIZONTAL WET COIL PRESSURE DROP

UNIT SIZE	STANDARD CFM (S.C.F.M)														
	600	700	800	900	1000	1100	1200	1300	1400	1500	1600	1700	1800	1900	2000
30	-	0.037	0.044	0.053	0.063	0.072	0.081	0.105	-	-	-	-	-	-	-
36	-	-	-	0.055	0.060	0.090	0.100	0.110	0.140	-	-	-	-	-	-
42	-	-	-	-	0.045	0.050	0.060	0.065	0.075	0.080	0.090	0.094	0.110	-	-
48	-	-	-	-	-	-	0.041	0.063	0.085	0.100	0.104	0.110	0.120	0.130	-
60	-	-	-	-	-	-	-	-	-	0.060	0.065	0.072	0.077	0.085	0.100

### WET COIL AIR DELIVERY - DOWNFLOW - HIGH SPEED WITH 1-IN. (25 MM) FILTER AND ECONOMIZER

UNIT SIZE	EXTERNAL STATIC PRESSURE (in. W.C.)										
	0.1	0.2	0.3	0.4	0.5	0.6	0.7	0.8	0.9	1.0	
36	1333	1289	1256	1214	1152	1118	1076	1035	997	950	
42	1612	1569	1527	1481	1451	1393	1351	1317	1278	1242	
48	2166	2085	2002	1919	1798	1709	1582	1467	1270	988	
60	2298	2239	2180	2110	2044	1951	1862	1777	1697	1591	

### HORIZONTAL FILTER PRESSURE DROP TABLE (IN. W.C.)

FILTER SIZE in. (mm)	CFM																		
	500	600	700	800	900	1000	1100	1200	1300	1400	1500	1600	1700	1800	1900	2000	2100	2200	2300
20X24X1 (508X610x25)	-	-	-	-	0.09	0.10	0.11	0.13	0.14	0.15	0.16	-	-	-	-	-	-	-	-
24X30X1 (610X762x25)	-	-	-	0.04	0.05	0.06	0.07	0.07	0.08	0.09	0.1	-	-	-	-	-	-	-	-
24X36X1 (610X914X25)	-	-	-	-	-	-	-	0.06	0.07	0.07	0.08	0.09	0.09	0.10	0.11	0.12	0.13	0.14	0.14

### HORIZONTAL ECONOMIZER 1-IN. (25 MM) FILTER PRESSURE DROP (IN. W.C.)

UNIT PGD4/PGS4	PRESSURE DROP
30-36	0.20
42-60	0.25

### GAS ADJUSTMENT

#### NATURAL GAS ORIFICE SIZES AND MANIFOLD PRESSURE

Nameplate Input (Btu/hr)		ALTITUDE OF INSTALLATION (FT. ABOVE SEA LEVEL) U.S.A.*				
		0 to 2000 (0-610 m)	2001 to 3000* (611 to 914 m)	3001 to 4000 (915 to 1219 m)	4001 to 5000 (1220 to 1524 m)	5001 to 6000 (1524 to 1829 m)
40000	Orifice No. (Qty)	44 (2)	45 (2)†	48 (2)†	48 (2)†	48 (2)†
	Manifold Press.	3.2	3.2	3.8	3.5	3.2
60000	Orifice No. (Qty)	38 (2)	41 (2)†	41 (2)†	42 (2)†	42 (2)†
	Manifold Press.	3.6	3.8	3.4	3.4	3.2
90000	Orifice No. (Qty)	38 (3)	41 (3)†	41 (3)†	42 (3)†	42 (3)†
	Manifold Press.	3.6	3.8	3.4	3.4	3.2
115000	Orifice No. (Qty)	33 (3)	36 (3)†	36 (3)†	36 (3)†	38 (3)†
	Manifold Press.	3.8	3.8	3.6	3.3	3.6
130000	Orifice No. (Qty)	31 (3)	31 (3)	33 (3)†	33 (3)†	34 (3)†
	Manifold Press.	3.8	3.2	3.7	3.4	3.3

\*In the U.S.A., the input rating for altitudes above 2000 ft (610m) must be reduced by 4% for each 1000 ft (305 m) above Sea level.

In Canada, the input rating for altitudes from 2001 to 4500 ft (611 to 1372 m) above sea level must be derated by 10% by an authorized gas conversion station or dealer.

For Canadian Installations from 2000 to 4500 ft, use U.S.A. column 2001 to 3000 ft.

Note: Orifice sizes and manifold pressure settings are based on natural gas with a heating value of 1025 Btu/ft3 and a specific gravity of .6.

† Orifices available through your distributor.

## PROPANE GAS ORIFICE SIZES AND MANIFOLD PRESSURE

Nameplate Input (Btu/hr)		ALTITUDE OF INSTALLATION (FT. ABOVE SEA LEVEL) U.S.A.*				
		0 to 2000 (0-610 m)	2001 to 3000* (611 to 914 m)	3001 to 4000 (915 to 1219 m)	4001 to 5000 (1220 to 1524 m)	5001 to 6000 (1524 to 1829 m)
40000	Orifice No. (Qty)	55 (2)	56 (2)	56 (2)	56 (2)	56 (2)
	Manifold Press. ("WC)	10.0	11.0	11.0	11.0	10.7
60000	Orifice No. (Qty)	53 (2)	54 (2)	54 (2)	54 (2)	54 (2)
	Manifold Press. ("WC)	10.0	11.0	11.0	11.0	11.0
90000	Orifice No. (Qty)	53 (3)	54 (3)	54 (3)	54 (3)	54 (3)
	Manifold Press. ("WC)	10.0	11.0	11.0	11.0	11.0
115000	Orifice No. (Qty)	51 (3)	52 (3)	52 (3)	53 (3)	53 (3)
	Manifold Press. ("WC)	10.0	11.0	10.6	11.0	11.0
130000	Orifice No. (Qty)	49 (3)	50 (3)	51 (3)	52 (3)	52 (3)
	Manifold Press. ("WC)	10.0	11.0	11.0	11.0	11.0

\*In the U.S.A., the input rating for altitudes above 2000 ft (610m) must be reduced by 4% for each 1000 ft (305 m) above Sea level.

In Canada, the input rating for altitudes from 2001 to 4500 ft (611 to 1372 m) above sea level must be derated by 10% by an authorized gas conversion station or dealer. For Canadian Installations from 2000 to 4500 ft (610-1372 m), use U.S.A. column 2001 to 3000 ft (611 to 914 m).

†Use Kit No. NPLPCONV013A00 (0-2000 ft [0-610 m] above sea level). Use Kit No. NPLPCONV014A00 (2001-6000 ft [611-1829 m] above sea level).

## HIGH ALTITUDE COMPENSATION, PROPANE GAS

Nameplate Input (Btu/hr)	Rated Heating Input (Btu/hr), LP Gas at Installation Altitude Above Sea Level, U.S.A.*				
	0 to 2000 ft (0-610 m)	2001 to 3000 ft* (611 to 914 m)	3001 to 4000 ft (915 to 1219 m)	4001 to 5000 ft (1220 to 1524 m)	5001 to 6000 ft (1524 to 1829 m)
40000	38000	31700	31700	31700	31200
60000	53000	45900	45900	45800	45800
90000	79000	68900	68900	68600	68600
115000	103000	100400	98900	83000	83000
130000	116000	115500	111800	101300	100400

\*In the U.S.A., the input rating for altitudes above 2000 ft (610m) must be reduced by 4% for each 1000 ft (305 m) above Sea level.

In Canada, the input rating for altitudes from 2001 to 4500 ft (611 to 1372 m) above sea level must be derated by 10% by an authorized gas conversion station or dealer. For Canadian Installations from 2000 to 4500 ft (610-1372 m), use U.S.A. column 2001 to 3000 ft (611 to 914 m).

## HIGH ALTITUDE COMPENSATION, NATURAL GAS

Nameplate Input (Btu/hr)	Rated Heating Input (Btu/hr), Natural Gas at Installation Altitude Above Sea Level, U.S.A.*				
	0 to 2000 ft (0-610 m)	2001 to 3000 ft* (611 to 914 m)	3001 to 4000 ft (915 to 1219 m)	4001 to 5000 ft (1220 to 1524 m)	5001 to 6000 ft (1524 to 1829 m)
40000	40000	36000	34400	32800	31200
60000	60000	54000	51600	49200	46800
90000	90000	81000	77400	73800	70200
115000	115000	103500	98900	94300	89700
130000	130000	117000	111800	106600	101400

\*In the U.S.A., the input rating for altitudes above 2000 ft (610m) must be reduced by 4% for each 1000 ft (305 m) above Sea level.

In Canada, the input rating for altitudes from 2001 to 4500 ft (611 to 1372 m) above sea level must be derated by 10% by an authorized gas conversion station or dealer. For Canadian Installations from 2000 to 4500 ft (610-1372 m), use U.S.A. column 2001 to 3000 ft (611 to 914 m).

**COOLING EXTENDED PERFORMANCE TABLE PG(D,S)430**

**CONDENSER ENTERING AIR TEMPERATURES °F (°C)**

EVAPORATOR AIR CFM/BF	EWB °F (°C)	75 (23.9)			85 (29.4)			95 (35)			105 (40.6)			115 (46.1)			125 (51.7)		
		Capacity MBtuh		Total Sys kW	Capacity MBtuh		Total Sys kW	Capacity MBtuh		Total Sys kW	Capacity MBtuh		Total Sys kW	Capacity MBtuh		Total Sys kW	Capacity MBtuh		Total Sys kW
		Total	Sens		Total	Sens		Total	Sens		Total	Sens		Total	Sens		Total	Sens	
875/0.03	57 (13.8)	26.99	26.99	1.86	26.03	26.03	2.08	24.84	24.84	2.31	23.28	23.28	2.55	21.63	21.63	2.82	19.83	19.83	3.11
	62 (16.6)	27.80	26.01	1.87	26.54	25.26	2.08	25.04	24.35	2.31	23.33	23.33	2.55	21.67	21.67	2.82	19.87	19.87	3.11
	63* (17.2)	28.37	21.21	1.87	27.09	20.50	2.09	25.54	19.70	2.32	23.41	18.68	2.55	21.13	17.63	2.81	18.66	16.51	3.08
1000/0.04	57 (13.8)	30.73	22.07	1.86	29.48	21.44	2.10	27.98	20.72	2.35	25.91	19.78	2.59	23.61	18.78	2.85	21.10	17.72	3.13
	62 (16.6)	33.46	17.78	1.87	32.40	17.30	2.10	31.09	16.72	2.36	29.42	16.04	2.64	27.07	15.10	2.93	24.52	14.14	3.21
	63* (17.2)	28.57	27.98	1.89	27.32	27.32	2.12	26.09	26.09	2.36	24.45	24.45	2.59	22.72	22.72	2.87	20.84	20.84	3.16
1125/0.05	57 (13.8)	29.05	22.65	1.89	27.73	21.95	2.13	26.13	26.13	2.36	24.49	24.49	2.60	22.76	22.76	2.87	20.87	20.87	3.16
	62 (16.6)	31.37	23.54	1.89	30.12	22.95	2.12	28.60	22.25	2.38	26.53	21.33	2.63	24.15	20.29	2.89	21.60	19.20	3.18
	63* (17.2)	33.95	18.56	1.90	32.92	18.14	2.14	31.61	17.60	2.39	30.05	16.99	2.68	27.65	16.09	2.98	25.04	15.12	3.26
1200/0.05	57 (13.8)	29.32	29.32	1.92	28.31	28.31	2.15	27.10	27.10	2.41	25.45	25.45	2.64	23.65	23.65	2.91	21.70	21.70	3.21
	62 (16.6)	29.36	29.36	1.92	28.35	28.35	2.15	27.14	27.14	2.41	25.49	25.49	2.64	23.68	23.68	2.92	21.73	21.73	3.21
	63* (17.2)	29.55	24.01	1.92	28.22	23.33	2.15	26.63	22.53	2.40	24.43	21.47	2.62	22.07	20.33	2.88	19.66	19.66	3.17
1350/0.06	57 (13.8)	31.84	24.91	1.92	30.59	24.37	2.15	29.08	23.70	2.41	27.00	22.80	2.68	24.60	21.73	2.93	22.02	20.55	3.22
	62 (16.6)	34.29	19.27	1.94	33.28	18.91	2.17	31.97	18.40	2.43	30.44	17.85	2.71	28.11	17.06	3.01	25.43	16.05	3.31
	63* (17.2)	34.29	19.27	1.94	33.28	18.91	2.17	31.97	18.40	2.43	30.44	17.85	2.71	28.11	17.06	3.01	25.43	16.05	3.31

See Legend and Notes on Page 14.

**COOLING EXTENDED PERFORMANCE TABLE PG(D,S)436**

**CONDENSER ENTERING AIR TEMPERATURES °F (°C)**

EVAPORATOR AIR CFM/BF	EWB °F (°C)	75 (23.9)			85 (29.4)			95 (35)			105 (40.6)			115 (46.1)			125 (51.7)		
		Capacity MBtuh		Total Sys kW	Capacity MBtuh		Total Sys kW	Capacity MBtuh		Total Sys kW	Capacity MBtuh		Total Sys kW	Capacity MBtuh		Total Sys kW	Capacity MBtuh		Total Sys kW
		Total	Sens		Total	Sens		Total	Sens		Total	Sens		Total	Sens		Total	Sens	
1050/0.04	57 (13.8)	32.04	32.04	2.19	31.05	31.05	2.46	29.67	29.67	2.74	27.89	27.89	3.04	25.97	25.97	3.38	23.86	23.86	3.76
	62 (16.6)	32.91	27.48	2.20	31.59	27.24	2.46	29.83	29.66	2.74	27.93	27.93	3.04	26.01	26.01	3.38	23.90	23.90	3.76
	63* (17.2)	33.62	22.38	2.21	32.24	22.10	2.47	30.40	21.63	2.75	27.88	20.90	3.04	25.18	20.09	3.37	22.23	19.16	3.72
1200/0.05	57 (13.8)	36.45	23.33	2.21	35.13	23.14	2.49	33.48	22.83	2.80	30.96	22.18	3.09	28.22	21.45	3.42	25.24	20.62	3.78
	62 (16.6)	39.67	18.74	2.22	38.63	18.63	2.50	37.24	18.38	2.81	35.25	17.95	3.16	32.48	17.21	3.51	29.45	16.41	3.88
	63* (17.2)	33.50	33.50	2.25	32.48	32.48	2.53	31.16	31.16	2.81	29.25	29.25	3.11	27.24	27.24	3.46	25.04	25.04	3.83
1350/0.06	57 (13.8)	33.79	29.49	2.25	32.53	32.53	2.53	31.22	31.22	2.82	29.30	29.30	3.11	27.28	27.28	3.46	25.08	25.08	3.84
	62 (16.6)	34.36	23.89	2.25	32.96	23.65	2.53	31.14	23.23	2.81	28.52	22.48	3.10	25.75	21.66	3.43	22.79	20.63	3.79
	63* (17.2)	37.19	24.89	2.25	35.85	24.76	2.54	34.20	24.50	2.85	31.64	23.89	3.16	28.84	23.16	3.49	25.80	22.30	3.85
1350/0.06	57 (13.8)	40.13	19.52	2.27	39.14	19.50	2.55	37.77	19.31	2.86	35.97	19.03	3.21	33.15	18.34	3.58	30.03	17.54	3.95
	62 (16.6)	34.72	34.72	2.30	33.67	33.67	2.58	32.38	32.38	2.89	30.42	30.42	3.18	28.32	28.32	3.53	26.03	26.03	3.91
	63* (17.2)	34.95	25.34	2.30	33.50	25.12	2.58	31.73	24.75	2.88	29.03	23.98	3.16	26.24	23.10	3.49	23.49	23.49	3.85
1350/0.06	57 (13.8)	37.71	26.36	2.30	36.39	26.30	2.58	34.73	26.08	2.90	32.19	25.52	3.22	29.33	24.77	3.55	26.31	23.80	3.92
	62 (16.6)	40.41	20.21	2.32	39.47	20.28	2.60	38.09	20.14	2.91	36.46	20.02	3.26	33.65	19.42	3.64	30.47	18.63	4.02
	63* (17.2)	40.41	20.21	2.32	39.47	20.28	2.60	38.09	20.14	2.91	36.46	20.02	3.26	33.65	19.42	3.64	30.47	18.63	4.02

See Legend and Notes on Page 14.

**COOLING EXTENDED PERFORMANCE TABLE PG(D,S)442**

**CONDENSER ENTERING AIR TEMPERATURES ° F (° C)**

EVAPORATOR AIR	75 (23.9)						85 (29.4)						95 (35)						105 (40.6)						115 (46.1)						125 (51.7)					
	CFM/BF	EWB °F (°C)	Capacity MBtuh		Total Sys kW	Total Sys kW	Capacity MBtuh		Total Sys kW	Total Sys kW	Capacity MBtuh		Total Sys kW	Total Sys kW	Capacity MBtuh		Total Sys kW	Total Sys kW	Capacity MBtuh		Total Sys kW	Total Sys kW	Capacity MBtuh		Total Sys kW	Total Sys kW										
			Total	Sens			Total	Sens			Total	Sens			Total	Sens			Total	Sens			Total	Sens			Total	Sens	Total	Sens						
	57 (13.8)	39.61	39.61	2.72	37.75	37.75	3.11	35.18	35.18	3.47	32.60	32.60	3.87	3.87	29.87	29.87	4.29	4.29	27.01	27.01	4.72	4.72	27.01	27.01	4.72	4.72										
	62 (16.6)	41.07	38.45	2.67	38.75	36.39	3.09	35.55	33.89	3.46	32.66	32.66	3.87	3.87	29.92	29.92	4.29	4.29	27.06	27.06	4.72	4.72	27.06	27.06	4.72	4.72										
<b>1225/0.03</b>	63* (17.2)	41.95	31.44	2.64	39.60	29.62	3.07	36.33	27.46	3.45	32.90	25.32	3.87	3.87	29.27	23.19	4.30	4.30	25.42	21.06	4.73	4.73	25.42	21.06	4.73	4.73										
	67 (19.4)	45.37	32.67	2.53	43.06	30.92	2.96	39.97	28.94	3.40	36.45	26.82	3.83	3.83	32.72	24.71	4.27	4.27	28.81	22.62	4.72	4.72	28.81	22.62	4.72	4.72										
	72 (22.2)	49.27	26.39	2.42	46.93	24.87	2.85	44.47	23.37	3.31	41.33	21.77	3.74	3.74	37.56	19.92	4.23	4.23	33.52	18.06	4.71	4.71	33.52	18.06	4.71	4.71										
	57 (13.8)	41.50	41.50	2.69	39.58	39.58	3.11	36.97	36.97	3.49	34.25	34.25	3.90	3.90	31.39	31.39	4.32	4.32	28.40	28.40	4.76	4.76	28.40	28.40	4.76	4.76										
	62 (16.6)	42.21	41.36	2.67	39.89	39.13	3.10	37.03	37.03	3.49	34.31	34.31	3.89	3.89	31.45	31.45	4.32	4.32	28.45	28.45	4.76	4.76	28.45	28.45	4.76	4.76										
<b>1400/0.04</b>	63* (17.2)	42.97	33.53	2.65	40.58	31.68	3.08	37.25	29.48	3.49	33.72	27.26	3.90	3.90	29.98	25.02	4.34	4.34	26.10	22.75	4.77	4.77	26.10	22.75	4.77	4.77										
	67 (19.4)	46.35	34.80	2.54	43.98	33.00	2.97	41.00	31.10	3.42	37.31	28.90	3.87	3.87	33.50	26.70	4.31	4.31	29.50	24.50	4.76	4.76	29.50	24.50	4.76	4.76										
	72 (22.2)	50.00	27.51	2.44	47.63	26.00	2.87	45.07	24.46	3.33	42.19	23.04	3.76	3.76	38.40	21.21	4.25	4.25	34.25	19.32	4.76	4.76	34.25	19.32	4.76	4.76										
	57 (13.8)	43.07	43.07	2.68	41.12	41.12	3.10	38.51	38.51	3.52	35.67	35.67	3.92	3.92	32.70	32.70	4.36	4.36	29.59	29.59	4.80	4.80	29.59	29.59	4.80	4.80										
	62 (16.6)	43.17	43.17	2.68	41.17	41.17	3.10	38.57	38.57	3.52	35.73	35.73	3.92	3.92	32.75	32.75	4.36	4.36	29.63	29.63	4.80	4.80	29.63	29.63	4.80	4.80										
<b>1575/0.05</b>	63* (17.2)	43.75	35.51	2.67	41.32	33.62	3.10	37.99	31.40	3.52	34.37	29.08	3.94	3.94	30.58	26.74	4.37	4.37	26.77	26.77	4.81	4.81	26.77	26.77	4.81	4.81										
	67 (19.4)	47.03	36.77	2.56	44.64	34.95	2.99	41.77	33.12	3.44	38.00	30.88	3.90	3.90	34.12	28.58	4.35	4.35	30.10	26.23	4.80	4.80	30.10	26.23	4.80	4.80										
	72 (22.2)	50.51	28.53	2.47	48.10	27.01	2.90	45.48	25.44	3.37	42.80	24.21	3.79	3.79	39.02	22.42	4.27	4.27	34.83	20.52	4.79	4.79	34.83	20.52	4.79	4.79										

See Legend and Notes on Page 14.

**COOLING EXTENDED PERFORMANCE TABLE PG(D,S)448**

**CONDENSER ENTERING AIR TEMPERATURES ° F (° C)**

EVAPORATOR AIR	75 (23.9)						85 (29.4)						95 (35)						105 (40.6)						115 (46.1)						125 (51.7)					
	CFM/BF	EWB °F (°C)	Capacity MBtuh		Total Sys kW	Total Sys kW	Capacity MBtuh		Total Sys kW	Total Sys kW	Capacity MBtuh		Total Sys kW	Total Sys kW	Capacity MBtuh		Total Sys kW	Total Sys kW	Capacity MBtuh		Total Sys kW	Total Sys kW	Capacity MBtuh		Total Sys kW	Total Sys kW										
			Total	Sens			Total	Sens			Total	Sens			Total	Sens			Total	Sens			Total	Sens			Total	Sens	Total	Sens						
	57 (13.8)	45.84	45.84	2.98	43.32	43.32	3.39	40.27	40.27	3.79	36.93	36.93	4.23	4.23	33.57	33.57	4.70	4.70	30.16	30.16	5.21	5.21	30.16	30.16	5.21	5.21										
	62 (16.6)	47.63	42.40	3.00	44.58	40.08	3.40	40.96	37.50	3.80	36.99	36.99	4.23	4.23	33.63	33.63	4.70	4.70	30.21	30.21	5.21	5.21	30.21	30.21	5.21	5.21										
<b>1400/0.04</b>	63* (17.2)	48.63	34.72	3.00	45.52	32.68	3.41	41.85	30.46	3.82	37.52	28.03	4.23	4.23	33.20	25.66	4.69	4.69	28.77	23.31	5.18	5.18	28.77	23.31	5.18	5.18										
	67 (19.4)	52.66	36.12	2.99	49.43	34.10	3.41	46.02	32.06	3.86	41.50	29.66	4.31	4.31	37.03	27.31	4.77	4.77	32.47	24.99	5.27	5.27	32.47	24.99	5.27	5.27										
	72 (22.2)	57.51	29.34	2.99	54.21	27.62	3.41	50.75	25.85	3.86	46.93	24.09	4.35	4.35	42.34	22.07	4.88	4.88	37.63	20.03	5.42	5.42	37.63	20.03	5.42	5.42										
	57 (13.8)	47.96	47.96	3.06	45.32	45.32	3.47	42.32	42.32	3.89	38.76	38.76	4.32	4.32	35.24	35.24	4.80	4.80	31.66	31.66	5.31	5.31	31.66	31.66	5.31	5.31										
	62 (16.6)	48.90	45.54	3.06	45.80	43.03	3.47	42.41	42.41	3.89	38.82	38.82	4.32	4.32	35.30	35.30	4.80	4.80	31.72	31.72	5.32	5.32	31.72	31.72	5.32	5.32										
	63* (17.2)	49.79	37.01	3.06	46.56	34.90	3.47	42.93	32.66	3.90	38.42	30.10	4.31	4.31	33.97	27.62	4.77	4.77	29.47	25.14	5.26	5.26	29.47	25.14	5.26	5.26										
	67 (19.4)	53.81	38.48	3.05	50.48	36.40	3.46	47.00	34.30	3.92	42.43	31.88	4.39	4.39	37.88	29.44	4.86	4.86	33.20	27.00	5.35	5.35	33.20	27.00	5.35	5.35										
<b>1600/0.05</b>	72 (22.2)	58.37	30.60	3.05	55.05	28.87	3.47	51.47	27.05	3.93	47.81	25.40	4.41	4.41	43.22	23.43	4.94	4.94	38.39	21.38	5.50	5.50	38.39	21.38	5.50	5.50										
	57 (13.8)	49.74	49.74	3.12	47.00	47.00	3.53	44.06	44.06	3.98	40.29	40.29	4.41	4.41	36.64	36.64	4.89	4.89	32.92	32.92	5.41	5.41	32.92	32.92	5.41	5.41										
	62 (16.6)	50.02	49.61	3.11	47.06	47.06	3.53	44.13	44.13	3.98	40.35	40.35	4.41	4.41	36.69	36.69	4.89	4.89	32.97	32.97	5.41	5.41	32.97	32.97	5.41	5.41										
<b>1800/0.06</b>	63* (17.2)	50.68	39.21	3.11	47.38	37.03	3.53	43.79	34.77	3.98	39.13	32.09	4.38	4.38	34.61	29.48	4.84	4.84	30.08	26.75	5.33	5.33	30.08	26.75	5.33	5.33										
	67 (19.4)	54.66	40.72	3.10	51.27	38.58	3.52	47.75	36.43	3.97	43.18	34.03	4.47	4.47	38.53	31.47	4.93	4.93	33.83	28.88	5.44	5.44	33.83	28.88	5.44	5.44										
	72 (22.2)	58.98	31.74	3.11	55.61	30.01	3.53	51.97	28.16	3.99	48.35	26.51	4.48	4.48	43.87	24.71	4.99	4.99	38.98	22.66	5.56	5.56	38.98	22.66	5.56	5.56										

See Legend and Notes on Page 14.

**COOLING EXTENDED PERFORMANCE TABLE PG(D,S)460**

**CONDENSER ENTERING AIR TEMPERATURES °F (°C)**

EVAPORATOR AIR CFM/BF	EWB °F (°C)	75 (23.9)			85 (29.4)			95 (35)			105 (40.6)			115 (46.1)			125 (51.7)		
		Capacity MBtuh		Total	Capacity MBtuh		Total	Capacity MBtuh		Total	Capacity MBtuh		Total	Capacity MBtuh		Total	Capacity MBtuh		Total
		Total	Sens	Sys kW	Total	Sens	Sys kW	Total	Sens	Sys kW	Total	Sens	Sys kW	Total	Sens	Sys kW	Total	Sens	Sys kW
1750/0.19	57 (13.8)	57.97	57.97	3.80	55.02	55.02	4.21	51.93	51.93	4.68	48.68	48.68	5.21	45.23	45.23	5.81	41.56	41.56	6.49
	62 (16.6)	59.45	53.94	3.82	55.93	51.73	4.22	52.32	49.43	4.68	48.74	48.74	5.21	45.29	45.29	5.81	41.61	41.61	6.49
	63* (17.2)	60.48	43.88	3.83	56.84	41.90	4.23	53.09	39.89	4.69	49.17	37.85	5.21	45.08	35.75	5.80	40.81	33.61	6.47
	67 (19.4)	65.05	45.58	3.88	61.08	43.55	4.29	57.00	41.50	4.75	52.75	39.41	5.27	48.31	37.28	5.86	43.70	35.10	6.52
	72 (22.2)	71.36	36.96	3.97	66.97	35.08	4.38	62.43	33.17	4.83	57.72	31.22	5.35	52.82	29.25	5.94	47.74	27.24	6.59
2000/0.23	57 (13.8)	60.36	60.36	3.91	57.19	57.19	4.32	53.88	53.88	4.79	50.41	50.41	5.31	46.72	46.72	5.91	42.83	42.83	6.59
	62 (16.6)	60.82	57.92	3.91	57.29	57.29	4.32	53.96	53.96	4.79	50.47	50.47	5.32	46.78	46.78	5.92	42.88	42.88	6.59
	63* (17.2)	61.65	46.80	3.92	57.84	44.73	4.33	53.93	42.64	4.78	49.88	40.51	5.30	45.65	38.32	5.89	41.27	36.06	6.56
	67 (19.4)	66.24	48.72	3.98	62.11	46.60	4.39	57.86	44.46	4.85	53.47	42.28	5.36	48.88	40.05	5.95	44.14	37.77	6.61
	72 (22.2)	72.62	38.94	4.06	68.04	36.99	4.47	63.32	35.02	4.93	58.45	33.03	5.45	53.38	30.99	6.03	48.15	28.93	6.68
2250/0.27	57 (13.8)	62.35	62.35	4.01	58.99	58.99	4.43	55.49	55.49	4.89	51.82	51.82	5.42	47.93	47.93	6.02	43.84	43.84	6.69
	62 (16.6)	62.44	62.44	4.01	59.07	59.07	4.43	55.56	55.56	4.89	51.88	51.88	5.42	47.99	47.99	6.02	43.88	43.88	6.69
	63* (17.2)	62.51	49.60	4.01	58.59	47.45	4.42	54.57	45.27	4.87	50.40	43.04	5.39	46.08	40.74	5.98	41.62	38.30	6.65
	67 (19.4)	67.13	51.74	4.07	62.86	49.53	4.48	58.50	47.31	4.94	53.98	45.03	5.46	49.29	42.69	6.04	44.47	40.24	6.70
	72 (22.2)	73.55	40.84	4.16	68.82	38.84	4.57	63.97	36.82	5.02	58.95	34.76	5.54	53.76	32.68	6.12	48.40	30.58	6.77

\* At 75°F (24°C) entering dry bulb—Tennessee Valley Authority (TVA) rating conditions; all others at 80°F dry bulb.

**LEGEND**

- BF—Bypass Factor
- edb—Entering Dry—Bulb
- Ewb—Entering Wet—Bulb
- kw—Total Unit Power Input
- SHC—Sensible Heat Capacity (1000 Btuh)
- TC—Total Capacity (1000 Btuh) (net)
- rh—Relative Humidity

**COOLING NOTES:**

1. Ratings are net; they account for the effects of the evaporator—fan motor power and heat.
2. Direct interpolation is permissible. Do not extrapolate.
3. The following formulas may be used:

$$t_{ldb} = t_{edb} - \frac{\text{Sensible capacity (Btuh)}}{1.10 \times \text{cfm}}$$

$$t_{lwb} = \frac{\text{Wet-bulb temperature corresponding to enthalpy air leaving evaporator coil (} h_{lwb} \text{)}}{\text{air leaving evaporator coil (} h_{lwb} \text{)}} = \frac{\text{total capacity (Btuh)}}{4.5 \times \text{cfm}}$$

Where:  $h_{lwb}$  = Enthalpy of air entering evaporator coil

4. The SHC is based on 80°F (26.6°C) edb temperature of air entering evaporator coil. Below 80°F (26.6°C) edb, subtract (corr factor x cfm) from SHC.
- Above 80°F (26.6°C) edb, add (corr factor x cfm) to SHC.

$$\text{Correction Factor} = 1.10 \times (1 + \text{BF}) \times (\text{edb} + 80)$$

5. Integrated capacity is maximum (instantaneous) capacity less the effect of frost on the outdoor coil and the heat required to defrost it.

# UNIT DIMENSIONS - PGD4, PGS4

UNIT PGD/SG4	ELECTRICAL CHARACTERISTICS	UNIT WT.		UNIT HEIGHT IN/MM	CENTER OF GRAVITY IN/MM		
		LB	KG		X	Y	Z
30040/080	208/230/460	342	155.0	39-15/16 [1014.4]	22-13/16 [579.4]	15-5/16 [388.9]	15-13/16 [401.6]
36060/090	208/230/460	376	170.4	45-15/16 [1166.8]	22-13/16 [579.4]	15-5/16 [388.9]	16-5/8 [422.3]

Unit	CORNER WEIGHT LB/KG		
	"1"	"2"	"3"
PGD/SG4	51.3	68.4	31.0
30040/080	51.3	68.4	31.0
36060/090	56.4	75.2	34.1

REQUIRED CLEARANCES NO COMBUSTIBLE MAIL		INCHES [MM]
TOP OF UNIT		14 [355.6]
UCT SIDE OF UNIT		2 [50.8]
SIDE OPPOSITE DUCTS		14 [355.6]
BOTTOM OF UNIT		12 [304.8]
FLUE PANEL		36 [914.4]

VEC. REQUIRED CLEARANCES		INCHES [MM]
BETWEEN UNITS, POWER ENTRY SIDE		42 [1066.8]
BETWEEN UNITS, POWER ENTRY SIDE		36 [914.0]
UNIT AND BLOCK OR CONCRETE WALLS AND OTHER GROUNDED SURFACES, POWER ENTRY SIDE		42 [1066.8]

REQUIRED CLEARANCE FOR OPERATION AND SERVICING		INCHES [MM]
EVAP. COIL ACCESS SIDE		36 [914.0]
POWER ENTRY SIDE		42 [1066.8]
(EXCEPT FOR NEC REQUIREMENTS)		
SIDE OPPOSITE DUCTS		48 [1219.2]
DUCT PANEL		36 [914.0]
DUCT PANEL		12 [304.8]

\*MINIMUM DISTANCES: IF UNIT IS PLACED LESS THAN 12 (304.8) FROM WALL SYSTEM, THEN SYSTEM PERFORMANCE MAY BE COMPROMISED.

DIMENSIONS IN [ ] ARE IN MM

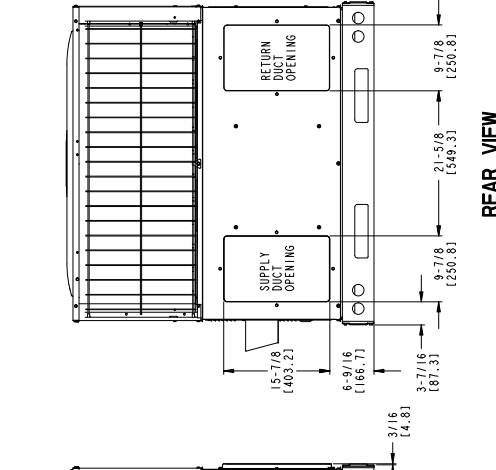
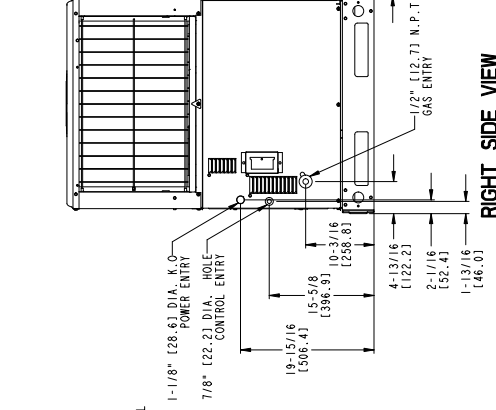
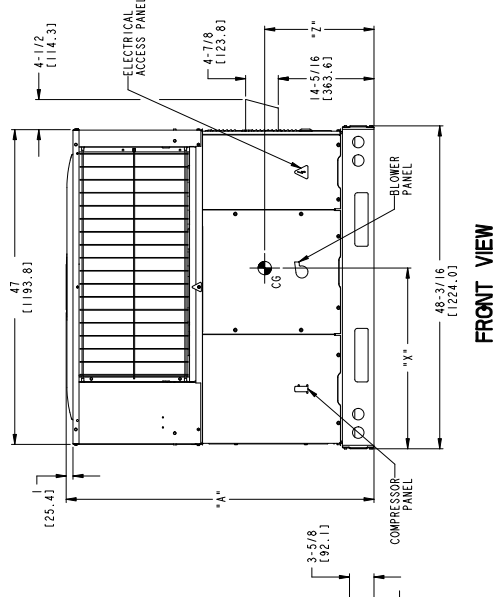
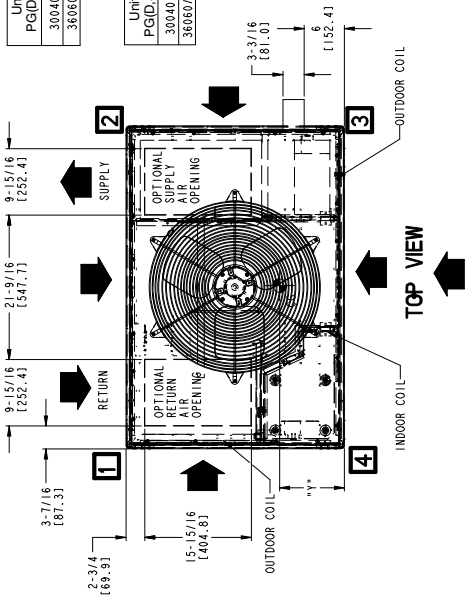

48VL500191  
REV 2.0

# UNIT DIMENSIONS - PGD4, PGS4

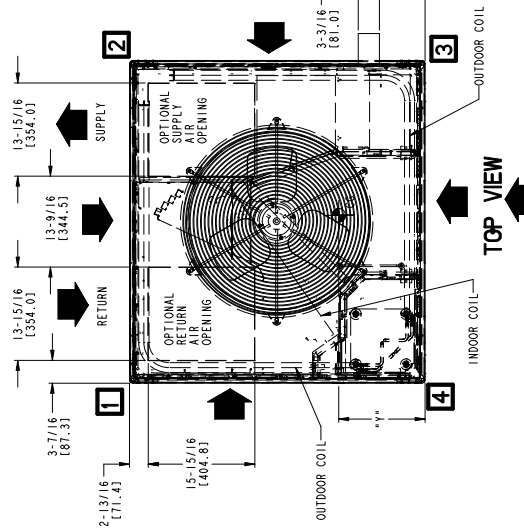

Unit PG(D/S)4	ELECTRICAL CHARACTERISTICS	UNIT WT.		UNIT HEIGHT IN/MM		CENTER OF GRAVITY IN/MM					
		LB	KG	"A"	"X"	Y	Z				
42060/090	208/230/460	463	210.1	49-7/8"	1266.8	22-13/16"	579.4	18	457.2	17-1/8"	435.0
48090/115/130	208/230/460	481	218.3	49-7/8"	1266.8	22-13/16"	579.4	18	457.2	17-3/8"	441.3
60090/115/130	208/230/460	509	231.0	53-7/8"	1363.4	22-13/16"	579.4	18	457.2	17-5/8"	447.7

**REQUIRED CLEARANCES TO COMBUSTIBLE MATERIAL**

Unit PG(D/S)4	"1"	"2"	"3"	"4"	INCHES (MM)						
42060/090	69.5	31.5	92.6	42.1	139.0	63.1	162.1	73.6	1870.0	14	[355.6]
48090/115/130	69.5	31.5	92.6	42.1	139.0	63.1	162.1	73.6	1870.0	2	[50.8]
60090/115/130	72.2	32.8	96.2	43.7	144.4	65.3	168.4	76.3	1948.0	12	[304.8]
	76.4	34.7	101.8	46.2	152.8	69.4	178.2	80.9	2058.0	36	[914.4]

**NEC REQUIRED CLEARANCES**

Unit PG(D/S)4	TOP OF UNIT	DUCT SIDE OF UNIT	DUCTS	BOTTOM OF UNIT	FLUE PANEL	INCHES (MM)
42060/090	42	42	42	42	42	[1066.8]
48090/115/130	36	36	36	36	36	[914.4]
60090/115/130	42	42	42	42	42	[1066.8]

**REQUIRED CLEARANCE FOR OPERATION AND SERVICING**

Unit PG(D/S)4	EVAP. COIL ACCESS SIDE	COMP. ACCESS SIDE	UNIT AND BLOCK OR CONCRETE WALLS AND OTHER GROUNDED SURFACES, POWER ENTRY SIDE	INCHES (MM)
42060/090	36	36	42	[1066.8]
48090/115/130	48	48	48	[1219.2]
60090/115/130	36	36	42	[1066.8]

\*MINIMUM DISTANCES-IF UNIT IS PLACED LESS THAN 12" (304.8) FROM WALL SYSTEM, THEN SYSTEM PERFORMANCE MAYBE COMPROMISED.

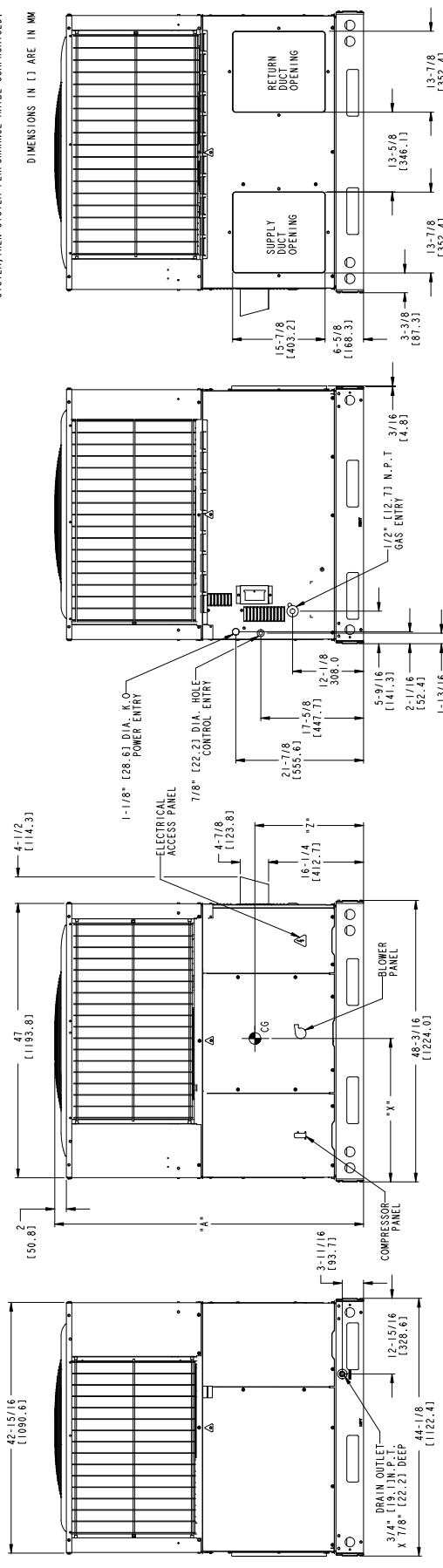

48VL500192  
REV 2.0

**DANGER: ELECTRICAL SHOCK HAZARD DISCONNECT POWER BEFORE SERVICING**

**NOTES:**

1. IF ANY OF THE ORIGINAL WIRES FURNISHED ARE REPLACED, THEY MUST BE REPLACED WITH TYPE 90 DEG. C WIRE OR ITS EQUIVALENT.
2. USE 75 DEG. COPPER CONDUCTORS FOR FIELD INSTALLATION.
3. SEE INSTALLATION INSTRUCTIONS FOR PROPER HEATING AND COOLING CONNECTIONS FOR YOUR UNIT. INDOOR FAN MOTOR PLUGS - "DO NOT DISCONNECT UNDER LOAD"
4. LS2 USED ON SMALL CHASSIS ONLY.
5. INDUCER CAPACITOR AND WIRING ON CERTAIN MODELS ONLY. IF CAP2 IS PRESENT, YELLOW WIRES FROM IGC AND IDM CONNECT ON SAME SIDE OF CAP2.
6. THIS FUSE IS MANUFACTURED BY LITTELFUSE, P/N 257003.
7. THIS FUSE IS MANUFACTURED BY LITTELFUSE, P/N 257005.
8. DEHUMIDIFICATION FEATURE CANNOT BE USED WHEN ECONOMIZER IS INSTALLED.

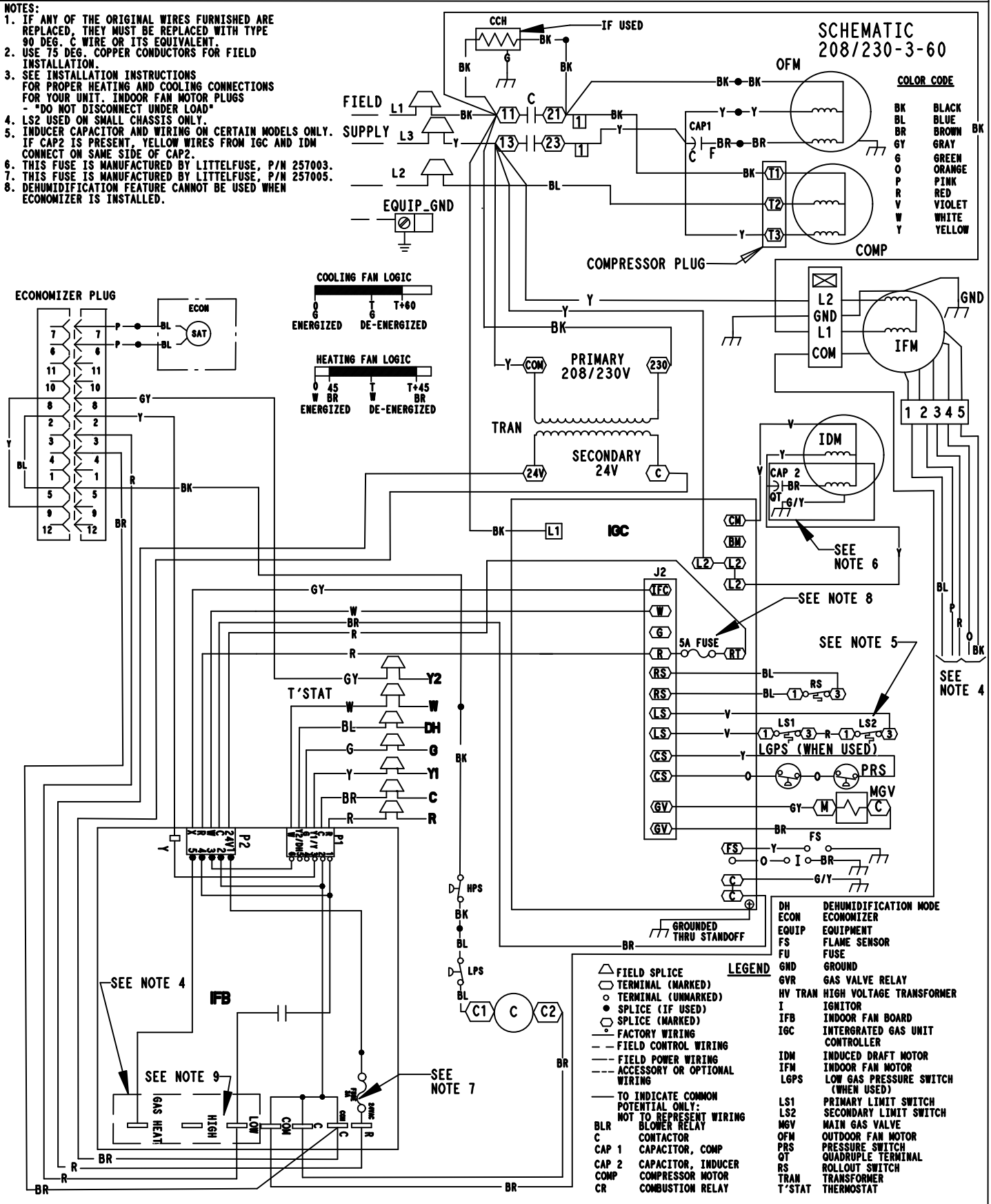



**DANGER: ELECTRICAL SHOCK HAZARD DISCONNECT POWER BEFORE SERVICING**

**SCHEMATIC  
460-3-60**

**NOTES:**

1. IF ANY OF THE ORIGINAL WIRES FURNISHED ARE REPLACED, THEY MUST BE REPLACED WITH TYPE 90 DEG. C WIRE OR ITS EQUIVALENT.
2. USE 75 DEG. COPPER CONDUCTORS FOR FIELD INSTALLATION.
3. SEE INSTALLATION INSTRUCTIONS FOR PROPER HEATING AND COOLING CONNECTIONS FOR YOUR UNIT. INDOOR FAN MOTOR PLUGS - "DO NOT DISCONNECT UNDER LOAD"
4. LS2 USED ON SMALL CHASSIS ONLY.
5. INDUCER CAPACITOR AND WIRING ON CERTAIN MODELS ONLY. IF CAP2 IS PRESENT, YELLOW WIRES FROM CONTACTOR AND IDM CONNECT ON SAME SIDE OF CAP2.
6. THIS FUSE IS MANUFACTURED BY LITTELFUSE, P/N 257003.
7. THIS FUSE IS MANUFACTURED BY LITTELFUSE, P/N 257005.
8. THESE FUSES ARE MANUFACTURED BY COOPER BUSSMAN, P/N FNQ-R-5.
9. DEHUMIDIFICATION FEATURE CANNOT BE USED WHEN ECONOMIZER IS INSTALLED.

**COLOR CODE**

BK	BLACK
BL	BLUE
BR	BROWN
GY	GRAY
GR	GREEN
OR	ORANGE
PK	PINK
RD	RED
VT	VIOLET
WH	WHITE
YL	YELLOW

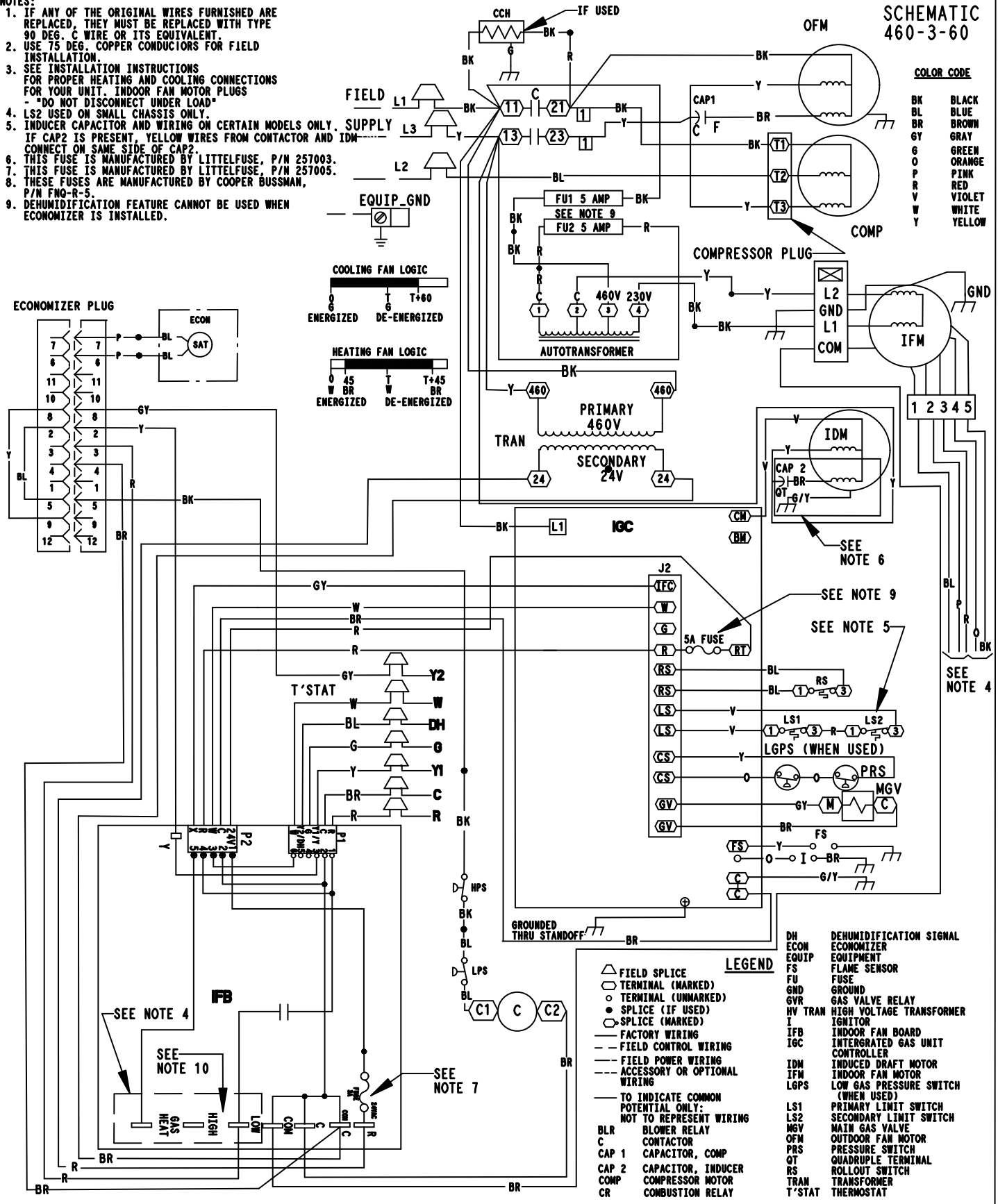

**LEGEND**

- △ FIELD SPLICE
- TERMINAL (MARKED)
- TERMINAL (UNMARKED)
- SPLICE (IF USED)
- SPLICE (MARKED)
- FACTORY WIRING
- - - FIELD CONTROL WIRING
- - - FIELD POWER WIRING
- - - ACCESSORY OR OPTIONAL WIRING
- TO INDICATE COMMON POTENTIAL ONLY: NOT TO REPRESENT WIRING
- BLR BLOWER RELAY
- C CONTACTOR
- CAP 1 CAPACITOR, COMP
- CAP 2 CAPACITOR, INDUCER
- COMP COMPRESSOR MOTOR
- CR COMBUSTION RELAY
- DH DEHUMIDIFICATION SIGNAL
- ECON ECONOMIZER
- EQUIP EQUIPMENT
- FS FLAME SENSOR
- FU FUSE
- GND GROUND
- GVR GAS VALVE RELAY
- HV TRAN HIGH VOLTAGE TRANSFORMER
- I IGNITOR
- IFB INDOOR FAN BOARD
- IGC INTEGRATED GAS UNIT CONTROLLER
- IDM INDUCED DRAFT MOTOR
- IFM INDOOR FAN MOTOR
- LGPS LOW GAS PRESSURE SWITCH (WHEN USED)
- LS1 PRIMARY LIMIT SWITCH (WHEN USED)
- LS2 SECONDARY LIMIT SWITCH (WHEN USED)
- MGV MAIN GAS VALVE
- OFM OUTDOOR FAN MOTOR
- PRS PRESSURE SWITCH
- QT QUADRUPLE TERMINAL
- RS ROLL-OFF SWITCH
- TRAN TRANSFORMER
- T'STAT THERMOSTAT



## CONTROLS

### OPERATING SEQUENCE

**Heating** – On a call for heating, terminal “W” of the thermostat is energized, starting the induced-draft motor. When the pressure switch senses that the induced-draft motor is moving sufficient combustion air, the burner sequence begins. This function is performed by the integrated gas unit controller (IGC). The indoor (evaporator)-fan motor is energized 45 sec after flame is established. When the thermostat is satisfied and “W” is de-energized, the burners stop firing and the indoor (evaporator) fan motor shuts off after a 45-sec time-off delay. Please note that the IGC has the capability to automatically reduce the indoor fan motor on delay and increase the indoor fan motor off delay in the event of high duct static and/or partially-clogged filter.

**Cooling** – When the system thermostat calls for cooling, 24 V is supplied to the “Y1/Y” and “G” terminals of the thermostat. This completes the circuit to the contactor coil (C) and indoor (evaporator) fan relay (IFR). The normally open contacts of energized C close and complete the circuit through compressor motor (COMP) to outdoor (condenser) fan motor (OFM). Both motors start instantly. The set of normally open contacts of energized IFR close and complete the circuit through IFM. The IFM starts instantly.

On the loss of the thermostat call for cooling, 24 V is removed from both the “Y1/Y” and “G” terminals (provided the fan switch is in the “AUTO” position) de-energizing the compressor contactor and opening the contacts supplying power to compressor/OFM. After a 90-second delay, the IFM shuts off. If the thermostat fan selector switch is in the “ON” position, the IFM will run continuously.

**NOTE:** On units with a anti-cycle timer: Once the compressor has started and then stopped, it cannot be restarted again until 5 minutes have elapsed.

ACCESSORIES

ECONOMIZER, FILTER RACK, and MANUAL OUTSIDE AIR DAMPER

ECONOMIZER

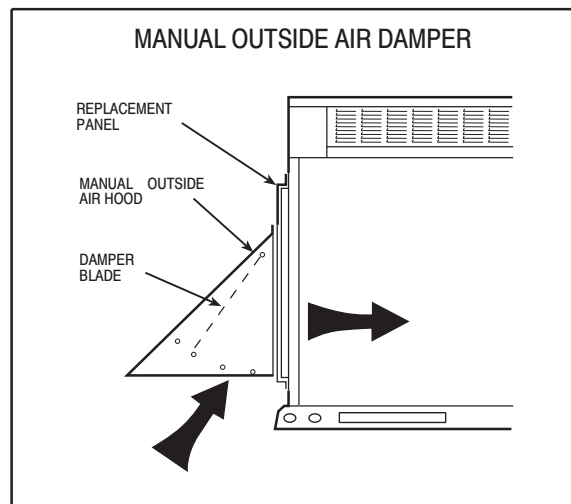
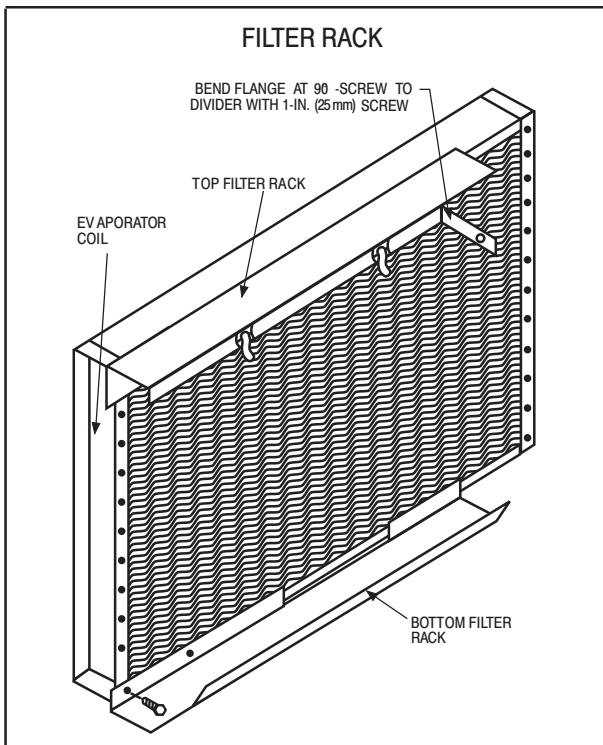
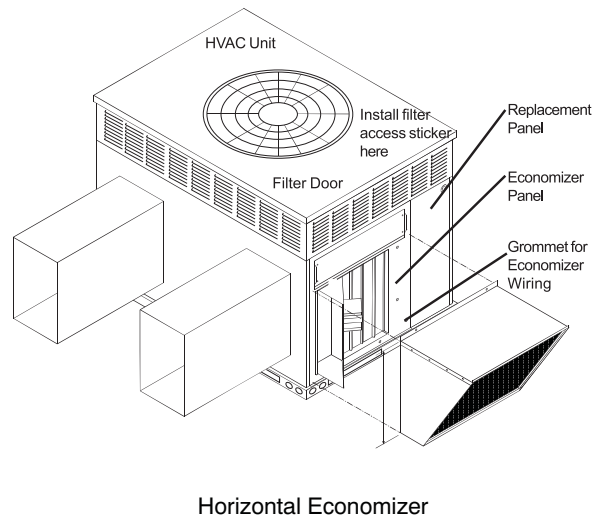
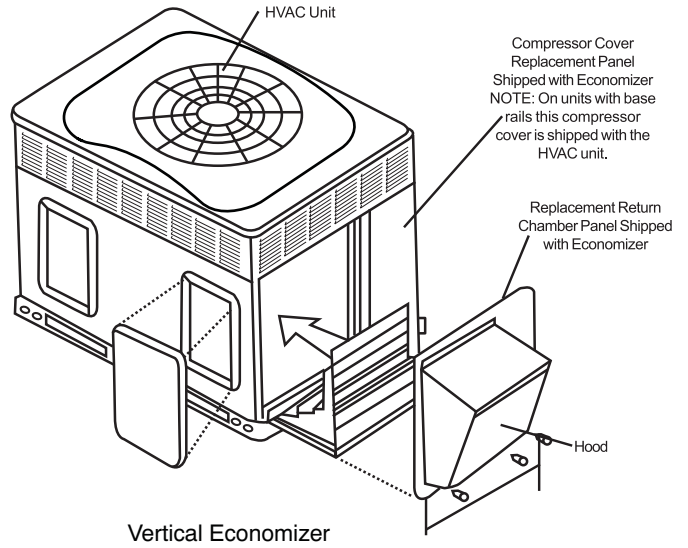
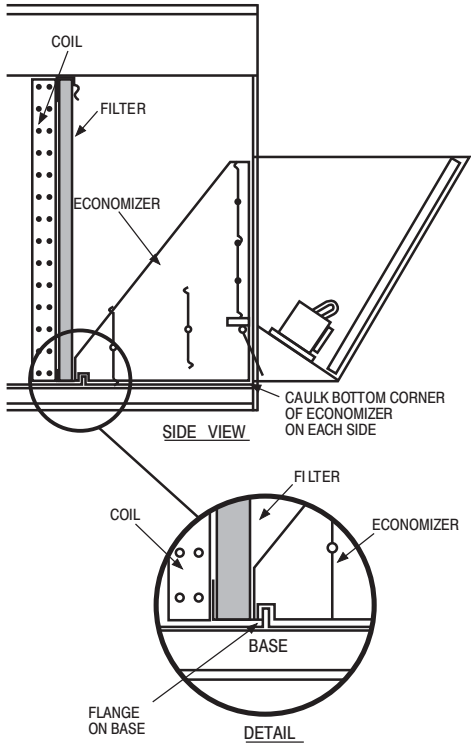

# ACCESSORIES

## ROOF CURBS

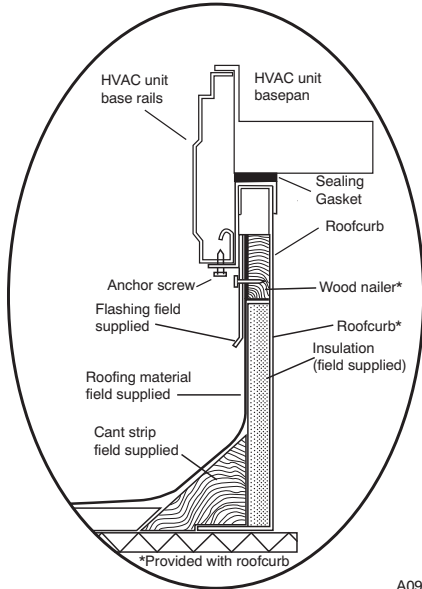

A09090

ROOF CURB DETAIL

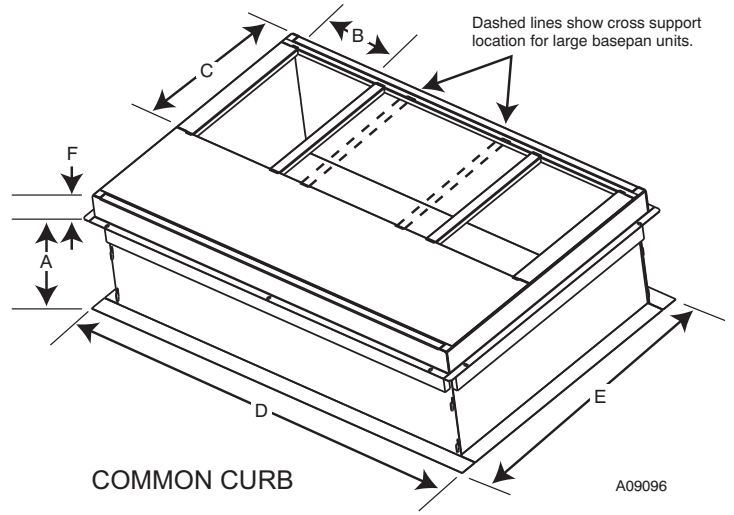

A09096

COMMON CURB

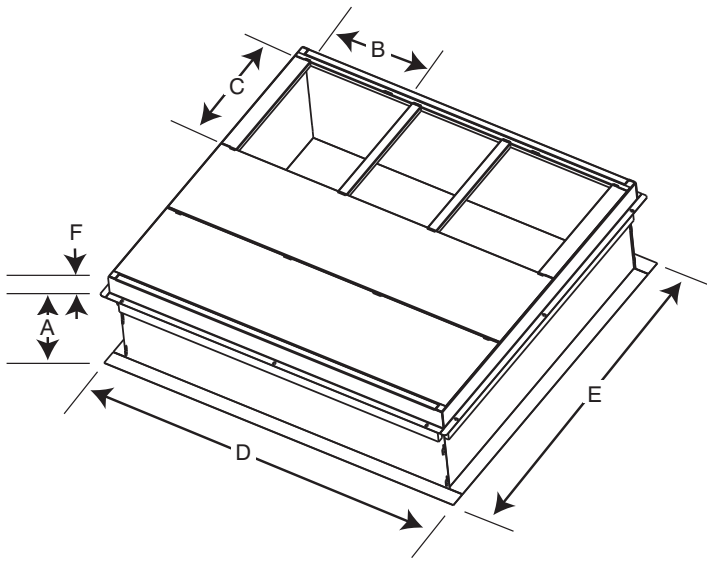

A09095

LARGE CURB

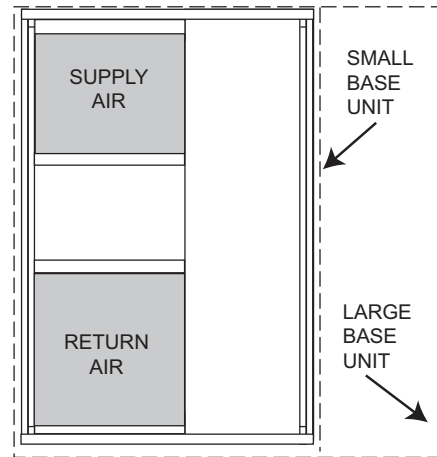

UNIT PLACEMENT ON COMMON CURB

A09094

SMALL OR LARGE BASE UNIT

A09097

UNIT SIZE	CATALOG NUMBER	A IN. (mm)	B (small base) IN. (mm)*	B (large base) IN. (mm)*	C IN. (mm)	D IN. (mm)	E IN. (mm)	F IN. (mm)
Small or Large	CPRFCURB010A00	11 (279)	10 (254)	14 (356)	16 (406)	47.8 (1214)	32.4 (822)	2.7 (69)
	CPRFCURB011A00	14 (356)						
Large	CPRFCURB012A00	11 (279)	N/A				43.9 (1116)	
	CPRFCURB013A00	14 (356)						

\* Part Numbers CPRFCURB010A00 and CPRFCURB011A00 can be used on both small and large basepan units. The cross supports must be located based on whether the unit is a small basepan or a large basepan.

NOTES:

1. Roof curb must be set up for unit being installed.
2. Seal strip must be applied, as required, to unit being installed.
3. Roof curb is made of 16-gauge steel.
4. Attach ductwork to curb (flanges of duct rest on curb).
5. Insulated panels: 1-in. (25.4 mm) thick fiberglass 1 lb. density.

**PGD4, PGS4 ACCESSORIES (Continued)**

<b>Accessory Model Number</b>	<b>Description</b>	<b>Use With</b>
<b>CURBS</b>		
CPRFCURB010A00	Roof Curb, 11" High	30 – 60
CPRFCURB011A00	Roof Curb, 14" High	30 – 60
CPRFCURB012A00	Roof Curb, 11" High	42 – 60
CPRFCURB013A00	Roof Curb, 14" High	42 – 60
<b>Note: CPRFCURB010A00 AND CPRFCURB011A00 can be used with 42–60 size units with some overhang.</b>		
<b>ADAPTER CURBS*</b>		
CPADCURB001A00	Adapter curb for use with NPRFCURB006A00 & NPRFCURB007A00	30 – 36
CPADCURB002A00	Adapter curb for use with NPRFCURB008A00 & NPRFCURB009A00	42 – 60
* Can also be used when replacing other manufacturer's older generation units that contain a composite base without a metal base rail.		
<b>CONCENTRIC ADAPTERS – (Use with curb only)</b>		
NPCONADP001A00	For 18" round duct (use with curbs CPRFCURB010A00, CPRFCURB011A00)	Small Curb
NPCONADP002A00	For 18" round duct (use with curbs CPRFCURB012A00, CPRFCURB013A00)	Large Curb
<b>CONCENTRIC DIFFUSERS – (Ceiling or under roof)</b>		
AXB020CSA*	Step Down Diffuser – Fits 2' x 4' Ceiling Grid (16" round collars for flex conn.)	30 – 42
AXB020CFA*	Flush Mount Diffuser – Fits 2' x 4' Ceiling Grid (16" round collars for flex conn.)	30 – 42
AXB030CSA	Step Down Diffuser – Fits 2' x 4' Ceiling Grid (18" round collars for flex conn.)	30 – 60
AXB030CFA	Flush Mount Diffuser – Fits 2' x 4' Ceiling Grid (18" round collars for flex conn.)	30 – 60
* A field supplied 18" to 16" round reducer required when used with NP concentric adaptor		
<b>ECONOMIZERS</b>		
CPECOMZR007A00	Dedicated Vertical Economizer – Internal with solid state controller, gear driven, fully modulating damper, spring return actuator, up to 50% barometric relief, supply and dry bulb outdoor air sensors. Includes filter rack with 1" filters*.	30 – 36
CPECOMZR008A00		42 – 48
CPECOMZR009A00		60
CPECOMZR010A00	Dedicated Horizontal Economizer – Internal with solid state controller, fully modulating damper, spring return actuator, supply and dry bulb outdoor air sensor, and low ambient compressor lockout switch included. Includes filter rack with 1–inch filters*.	30 – 36
CPECOMZR011A00		42 – 48
CPECOMZR012A00		60
AXB078ENT	Outdoor Enthalpy Control	ALL
* Outdoor enthalpy available as field installed accessory; Filter rack and 1" filter, same as CPFILTRK kit		
<b>DAMPERS</b>		
CPMANDPR007A00	Manual Outside Air Damper – (Includes filter rack and 1" filter, same as CPFILTRK kit)	30 – 36
CPMANDPR008A00		42 – 48
CPMANDPR009A00		60
<b>INTERNAL FILTER RACKS</b>		
CPFILTRK007A00	Internal Filter Rack (includes 1–inch filters)	30 – 36
CPFILTRK008A00		42 – 48
CPFILTRK009A00		60
<b>CRANKCASE HEATER – BELLY BAND TYPE</b>		
NPCRKHTR008A00	240V Crankcase Heater	30 – 36
NPCRKHTR004A00	240V Crankcase Heater (Included 60 size models)	42 – 48
NPCRKHTR009A00	460V Crankcase Heater	36
NPCRKHTR005A00	460V Crankcase Heater (Included 60 size models)	42 – 48
<b>LOW AMBIENT, ANTI–CYCLE TIMER</b>		
CPLOWAMB001A00	Low Ambient Control – enables cooling system to operate down to 0 Deg. F by cycling condenser fan on and off.	ALL
NRTIMEGD001A00	Five Minute Compressor Delay	ALL
<b>GAS CONVERSION KITS</b>		
NPLPCONV013A00	Natural to LP Conversion Kit ( 0 – 2000' )	ALL
NPLPCONV014A00	Natural to LP Conversion Kit ( 2001' – 6000' )	ALL
NPNGCONV004A00	LP to Natural Gas Conversion Kit ( 0 – 2000' )	ALL
<b>FLUE DISCHARGE DEFLECTOR</b>		
CRFLUEDS001A00	Directs flue gas exhaust 90 degrees upward from current discharge. Designed to allow tighter distances between unit and combustible surfaces. 24 inch Height. AGA certified.	ALL
<b>DUCT TRANSITIONS</b>		
NPDUCLG002A00	Square to 14" Round (1 set of 2, use with horizontal duct flanges only)	30–48