

INSTALLATION INSTRUCTIONS

R-410A Single Package Gas Heating / Electric Cooling

RGH072 - 120

These instructions must be read and understood completely before attempting installation.

Safety Labeling and Signal Words

DANGER, WARNING, CAUTION, and NOTE

The signal words **DANGER**, **WARNING**, **CAUTION**, and **NOTE** are used to identify levels of hazard seriousness. The signal word **DANGER** is only used on product labels to signify an immediate hazard. The signal words **WARNING**, **CAUTION**, and **NOTE** will be used on product labels and throughout this manual and other manuals that may apply to the product.

DANGER – Immediate hazards which **will** result in severe personal injury or death.

WARNING – Hazards or unsafe practices which **could** result in severe personal injury or death.

CAUTION – Hazards or unsafe practices which **may** result in minor personal injury or product or property damage.

NOTE – Used to highlight suggestions which **will** result in enhanced installation, reliability, or operation.

Signal Words in Manuals

The signal word **WARNING** is used throughout this manual in the following manner:

 **WARNING**

The signal word **CAUTION** is used throughout this manual in the following manner:

 **CAUTION**

Signal Words on Product Labeling

Signal words are used in combination with colors and/or pictures on product labels.

WARNING

ELECTRICAL SHOCK HAZARD

Failure to follow this warning could result in personal injury and/or death.

Before installing, modifying, or servicing system, main electrical disconnect switch must be in the OFF position. There may be more than 1 disconnect switch. Lock out and tag switch with a suitable warning label.

CAUTION

CUT HAZARD

Failure to follow this caution may result in personal injury

Sheet metal parts may have sharp edges or burrs. Use care and wear appropriate protective clothing and gloves when handling parts.

WARNING

PERSONAL INJURY AND ENVIRONMENTAL HAZARD

Failure to follow this warning could cause personal injury or death.

Relieve pressure and recover all refrigerant before system repair or final unit disposal.

Wear safety glasses and gloves when handling refrigerants. Keep torches and other ignitions sources away from refrigerants and oils.

WARNING

UNIT OPERATION AND SAFETY HAZARD

Failure to follow this warning could cause personal injury, death and/or equipment damage.

R-410A refrigerant systems operate at higher pressures than standard R-22 systems. Do not use R-22 service equipment or components on R-410A refrigerant equipment.

IMPORTANT – READ BEFORE INSTALLING

1. Read and become familiar with these installation instructions before installing this unit.
2. Be sure the installation conforms to all applicable local and national codes.
3. These instructions contain important information for the proper maintenance and repair of this equipment. Retain these instructions for future use.

CONTENTS

| | |
|---|----|
| SAFETY CONSIDERATIONS | 3 |
| INSTALLATION | 4 |
| Step 1 – Plan for Unit Location | 4 |
| Step 2 – Plan for Sequence of Unit Installation | 7 |
| Step 3 – Inspect unit | 7 |
| Step 4 – Provide Unit Support | 7 |
| Step 5 – Field Fabricate Ductwork | 9 |
| Step 6 – Rig and Place Unit | 9 |
| Step 7 – Convert to Horizontal and Connect Ductwork . | 10 |
| Step 8 – Install Outside Air Hood | 10 |
| Step 9 – Install Flue Hood | 11 |
| Step 10 – Install Gas Piping | 12 |
| Step 11 – Install External Condensate Trap & Piping ... | 14 |
| Step 12 – Make Electrical Connections | 14 |
| Step 13 – Adjust Factory–Installed Options | 23 |
| Step 14 – Install Accessories | 23 |
| START–UP CHECKLIST | 24 |

SAFETY CONSIDERATIONS

Improper installation, adjustment, alteration, service, maintenance, or use can cause explosion, fire, electrical shock or other conditions which may cause personal injury or property damage. Consult a qualified installer, service agency, or your distributor or branch for information or assistance. The qualified installer or agency must use factory–authorized kits or accessories when modifying this product. Refer to the individual instructions packaged with the kits or accessories when installing.

Follow all safety codes. Wear safety glasses and work gloves. Use quenching cloths for brazing operations and have a fire extinguisher available. Read these instructions thoroughly and follow all warnings or cautions attached to the unit. Consult local building codes and appropriate national electrical codes (in USA, ANSI/NFPA70, National Electrical Code (NEC); in Canada, CSA C22.1) for special requirements.

Recognize safety information. This is the safety–alert symbol.

When you see this symbol  in instructions or manuals, be alert to the potential for personal injury.

Understand the signal words **DANGER**, **WARNING**, **CAUTION**, and **NOTE**. These words are used with the safety–alert symbol. **DANGER** identifies the most serious hazards which **will** result in serious injury or death. **WARNING** signifies a hazard which **could** result in serious injury or death. **CAUTION** is used to identify unsafe practices which **may** result in minor personal injury or product and property damage. **NOTE** is used to highlight suggestions which **will** result in enhanced installation, reliability, or operation.

These instructions cover minimum requirements and conform to existing national standards and safety codes. In some instances, these instructions exceed certain local codes and ordinances, especially those that may not have kept up with changing residential construction practices. We require these instructions as a minimum for a safe installation.

WARNING

FIRE, EXPLOSION HAZARD

Failure to follow this warning could result in personal injury or death.

Disconnect gas piping from unit when leak testing at pressure greater than 0.5 psig (3450 Pa). Pressures greater than 0.5 psig (3450 Pa) will cause gas valve damage resulting in hazardous condition. If gas valve is subjected to pressure greater than 0.5 psig (3450 Pa), it must be replaced before use. When pressure testing field–supplied gas piping at pressures of 0.5 psig (3450 Pa) or less, a unit connected to such piping must be isolated by closing the manual gas valve.

WARNING

ELECTRICAL SHOCK HAZARD

Failure to follow this warning could cause personal injury or death.

Before performing service or maintenance operations on unit, always turn off main power switch to unit and install lockout tag. Unit may have more than one power switch.

INSTALLATION

WARNING

UNIT OPERATION AND SAFETY HAZARD

Failure to follow this warning could cause personal injury, death and/or equipment damage.

R–410A refrigerant systems operate at higher pressures than standard R–22 systems. Do not use R–22 service equipment or components on R–410A refrigerant equipment.

FIGURE 1

Base Unit Dimensions: RGH072-102

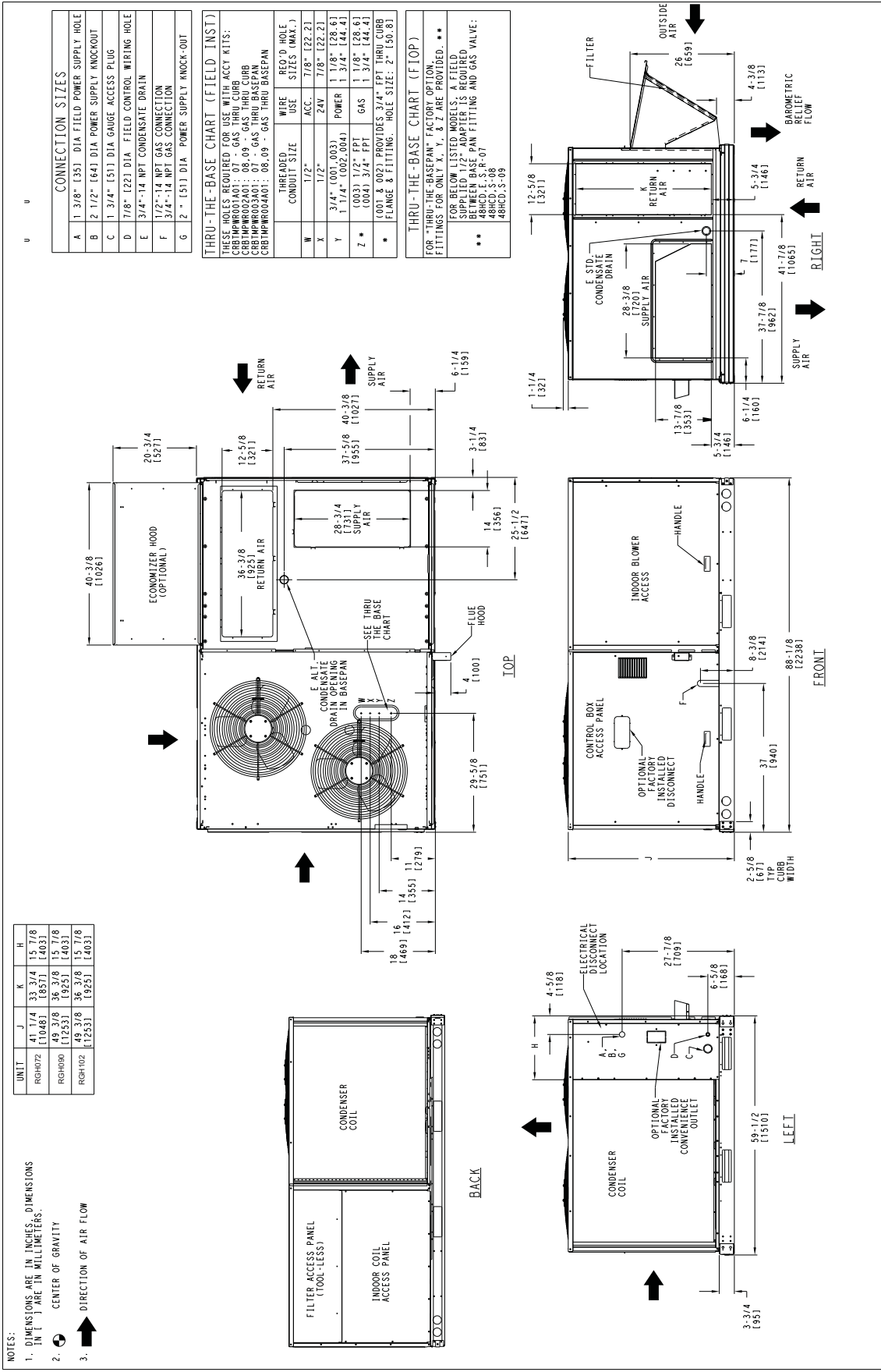

FIGURE 2

Base Unit Dimensions: RGH0110 - 120

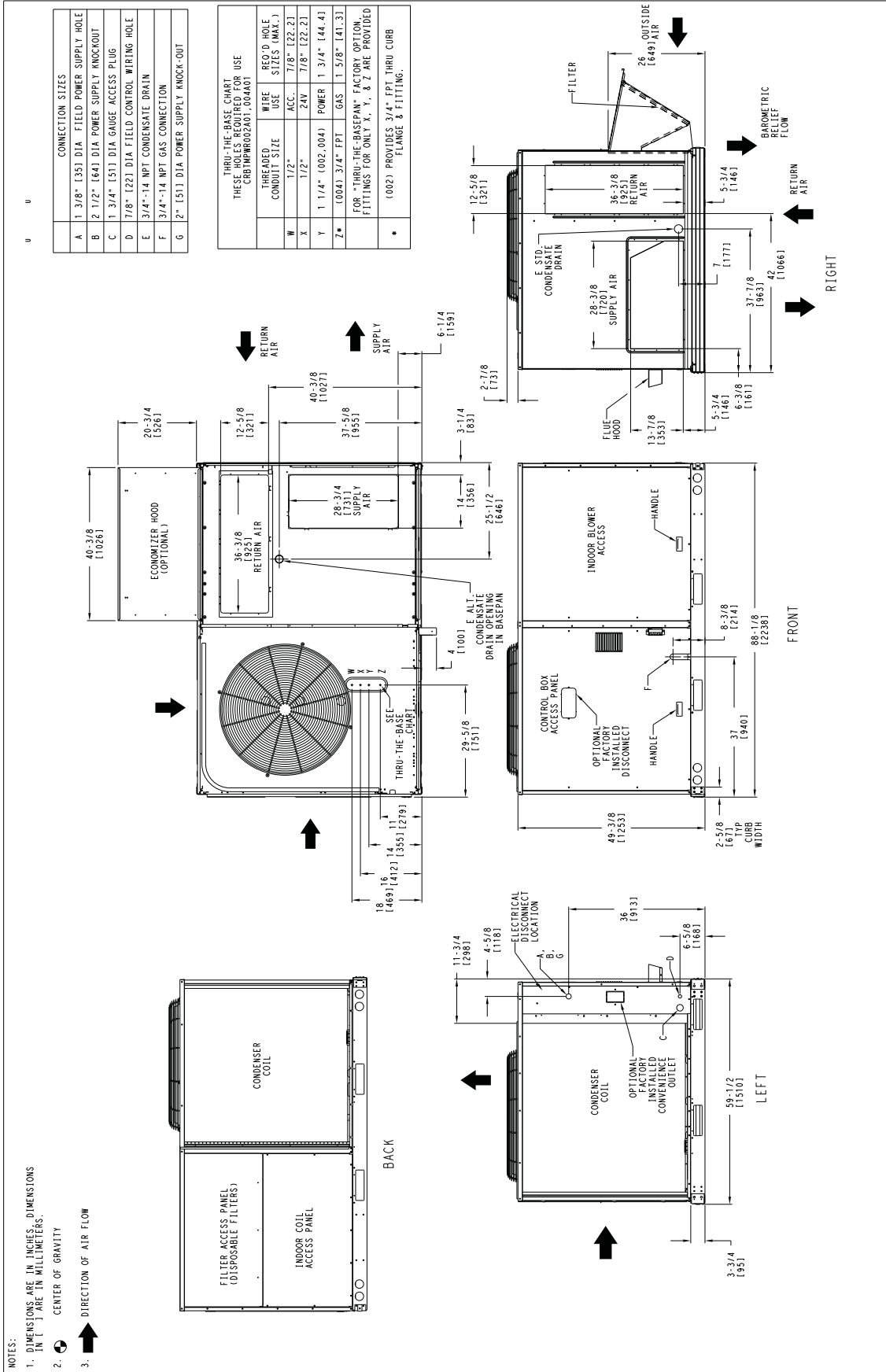
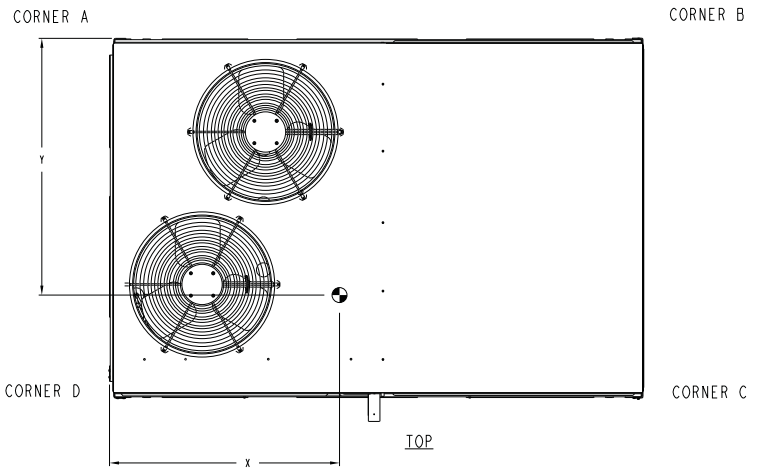
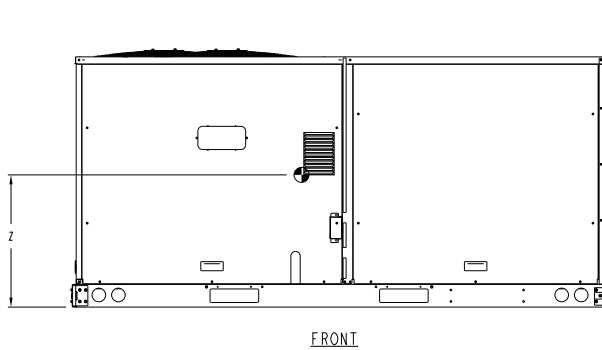

Figure 1A

Unit Dimensional Drawing 072-102(Cont.)

| UNIT | STD. UNIT WEIGHT * | | CORNER WEIGHT (A) | | CORNER WEIGHT (B) | | CORNER WEIGHT (C) | | CORNER WEIGHT (D) | | C.G. | | |
|--------|--------------------|-------|-------------------|------|-------------------|------|-------------------|-------|-------------------|-------|---------------|----------------|--------------|
| | LBS. | KG. | LBS. | KG. | LBS. | KG. | LBS. | KG. | LBS. | KG. | X | Y | Z |
| RGH072 | 765 | 347 | 165.3 | 75 | 152.7 | 69.3 | 214.7 | 97.4 | 232.3 | 105.4 | 42 3/8 [1076] | 34 3/4 [882.6] | 19 7/8 [505] |
| RGH090 | 925 | 419.5 | 204.1 | 92.6 | 190.9 | 86.6 | 256.1 | 116.2 | 273.9 | 124.2 | 42 5/8 [1082] | 34 1/8 [867] | 22 7/8 [581] |
| RGH102 | 925 | 419.5 | 204.1 | 92.6 | 190.9 | 86.6 | 256.1 | 116.2 | 273.9 | 124.2 | 42 5/8 [1082] | 34 1/8 [867] | 22 7/8 [581] |

* STANDARD UNIT WEIGHT IS WITH LOW GAS HEAT AND WITHOUT PACKAGING. FOR OTHER OPTIONS AND ACCESSORIES, REFER TO THE PRODUCT DATA CATALOG.



Unit Dimensional Drawing 110 - 120

| UNIT | STD. UNIT WEIGHT * | | CORNER WEIGHT (A) | | CORNER WEIGHT (B) | | CORNER WEIGHT (C) | | CORNER WEIGHT (D) | | C.G. | | |
|--------|--------------------|-----|-------------------|-----|-------------------|-----|-------------------|-----|-------------------|-----|--------------|--------------|--------------|
| | LBS. | KG. | LBS. | KG. | LBS. | KG. | LBS. | KG. | LBS. | KG. | X | Y | Z |
| RGH110 | 1090 | 495 | 311 | 142 | 162 | 74 | 211 | 96 | 405 | 184 | 30 1/8 [766] | 33 5/8 [855] | 20 3/4 [528] |
| RGH120 | 1090 | 495 | 311 | 142 | 162 | 74 | 211 | 96 | 405 | 184 | 30 1/8 [766] | 33 5/8 [855] | 20 3/4 [528] |

* STANDARD UNIT WEIGHT IS WITH LOW GAS HEAT AND WITHOUT PACKAGING. FOR OTHER OPTIONS AND ACCESSORIES, REFER TO THE PRODUCT DATA CATALOG.

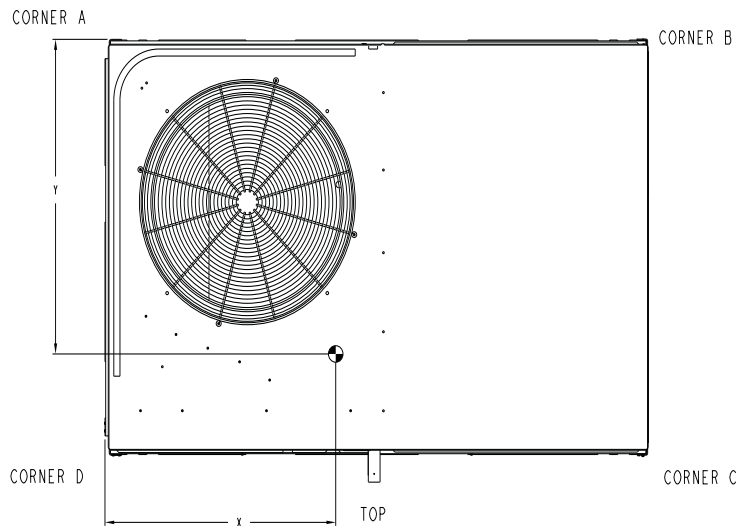
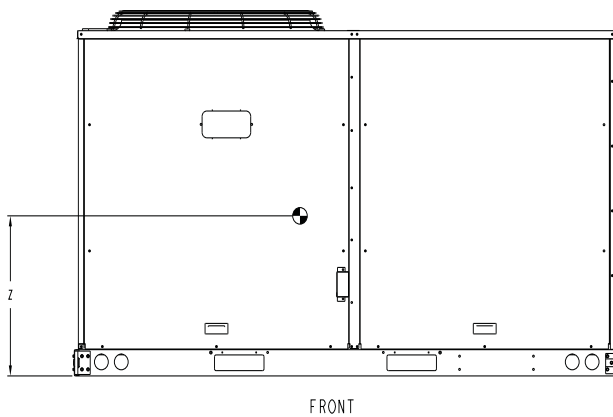

Jobsite Survey

Complete the following checks before installation.

1. Consult local building codes and the NEC (National Electrical Code) ANSI/NFPA 70 for special installation requirements.
2. Determine unit location (from project plans) or select unit location.
3. Check for possible overhead obstructions which may interfere with unit lifting or rigging.

Step 1 — Plan for Unit Location

Select a location for the unit and its support system (curb or other) that provides for the minimum clearances required for safety. This includes the clearance to combustible surfaces,

unit performance and service access below, around and above unit as specified in unit drawings. See Fig. 2.

NOTE: Consider also the effect of adjacent units.

Be sure that unit is installed such that snow will not block the combustion intake or flue outlet.

Unit may be installed directly on wood flooring or on Class A, B, or C roof-covering material when roof curb is used.

Do not install unit in an indoor location. Do not locate air inlets near exhaust vents or other sources of contaminated air. For proper unit operation, adequate combustion and ventilation air must be provided in accordance with Section

5.3 (Air for Combustion and Ventilation) of the National Fuel Gas Code, ANSI Z223.1 (American National Standards Institute) and NFPA (National Fire Protection Association) 54 TIA-54-84-1. In Canada, installation must be in accordance with the CAN1-B149 installation codes for gas burning appliances.

Although unit is weatherproof, avoid locations that permit water from higher level runoff and overhangs to fall onto the unit.

Locate mechanical draft system flue assembly at least 4 ft (1.2 m) from any opening through which combustion products could enter the building, and at least 4 ft (1.2 m) from any adjacent building (or per local code). Locate the

flue assembly at least 10 ft (3.05 m) from an adjacent unit's fresh air intake hood if within 3 ft (0.91 m) of same elevation (or per local code). When unit is located adjacent to public walkways, flue assembly must be at least 7 ft (2.1 m) above grade.

Select a unit mounting system that provides adequate height to allow installation of condensate trap per requirements. Refer to Step 11 — Install External Trap for Condensate Drain – for required trap dimensions.

Roof mount —

Check building codes for weight distribution requirements. Unit operating weight is shown in Table 1.

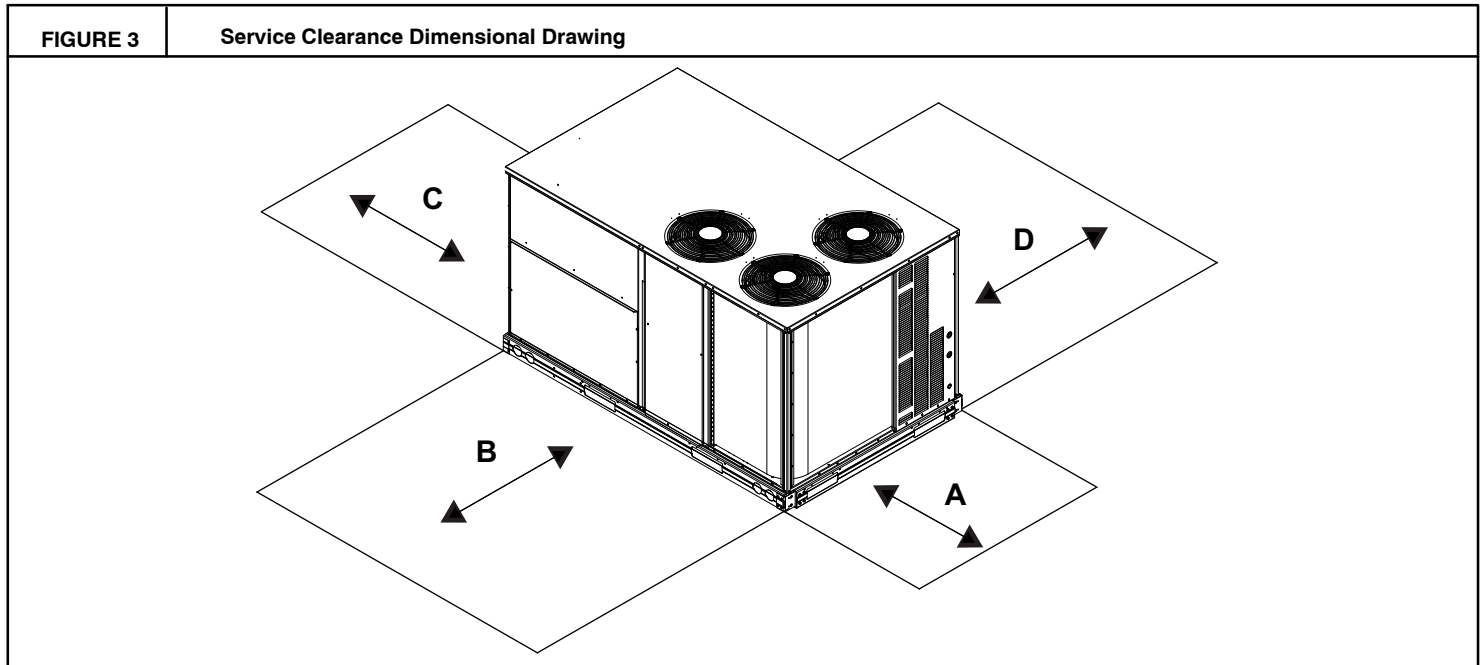

| LOCATION | DIMENSION | CONDITION |
|----------|---|--|
| A | 48-in (1219 mm) 18-in (457 mm) 18-in (457 mm) 12-in (305 mm) | Unit disconnect is mounted on panel No disconnect, convenience outlet option Recommended service clearance Minimum clearance |
| B | 42-in (1067 mm) 36-in (914 mm) Special | Surface behind servicer is grounded (e.g., metal, masonry wall) Surface behind servicer is electrically non-conductive (e.g., wood, fiberglass) Check sources of flue products within 10-ft of unit fresh air intake hood |
| C | 36-in (914 mm) 18-in (457 mm) | Side condensate drain is used Minimum clearance |
| D | 48-in (1219 mm) 42-in (1067 mm) 36-in (914 mm) Special | No flue discharge accessory installed, surface is combustible material Surface behind servicer is grounded (e.g., metal, masonry wall, another unit) Surface behind servicer is electrically non-conductive (e.g., wood, fiberglass) Check for adjacent units or building fresh air intakes within 10-ft (3 m) of this unit's flue outlet |

NOTE: Unit not designed to have overhead obstruction. Contact Application Engineering for guidance on any application planning overhead obstruction or for vertical clearances.

Table 1—Operating Weights

| RGH | UNITS LB (KG) | | | |
|-----------------------|---------------|-------------|-------------|------------|
| | 072 | 090 | 102 | 110/120 |
| Base Unit | 765 (347) | 925 (419.5) | 925 (419.5) | 1090 (495) |
| Economizer | | | | |
| Vertical | 75 (34) | 75 (34) | 75 (34) | 75 (34) |
| Horizontal | 122 (55) | 122 (55) | 122 (55) | 122 (55) |
| Powered Outlet | 35 (16) | 35 (16) | 35 (16) | 35 (16) |
| Hot Gas ReHeat System | 80 (36) | 80 (36) | 80 (36) | 85 (39) |
| Curb | | | | |
| 14-in/356 mm | 143 (65) | 143 (65) | 143 (65) | 143 (65) |
| 24-in/610 mm | 245 (111) | 245 (111) | 245 (111) | 245 (111) |

Step 2 — Plan for Sequence of Unit Installation

The support method used for this unit will dictate different sequences for the steps of unit installation. For example, on curb-mounted units, some accessories must be installed on the unit before the unit is placed on the curb. Review the following for recommended sequences for installation steps.

Curb-mounted installation —

- Install roof curb
- Install field-fabricated ductwork inside curb
- Install accessory thru-base service connection package, if used, (affects curb and unit) (refer to accessory installation instructions for details)
- Prepare condensate drain connection to suit planned condensate line routing (refer to Step 11 for details)
- Rig and place unit
- Install outdoor air hood
- Install flue hood
- Install gas piping
- Install condensate line trap and piping
- Make electrical connections
- Install other accessories

Pad-mounted installation —

- Prepare pad and unit supports
- Check and tighten the bottom condensate drain connection plug
- Rig and place unit
- Convert unit to side duct connection arrangement
- Install field-fabricated ductwork at unit duct openings
- Install outdoor air hood
- Install flue hood
- Install gas piping
- Install condensate line trap and piping
- Make electrical connections
- Install other accessories

Frame-mounted installation —

Frame-mounted applications generally follow the sequence for a curb installation. Adapt as required to suit specific installation plan.

Step 3 — Inspect unit

Inspect unit for transportation damage. File any claim with transportation agency.

Confirm before installation of unit that voltage, amperage and circuit protection requirements listed on unit data plate agree with power supply provided.

Step 4 — Provide Unit Support

Roof Curb Mount —

Accessory roof curb details and dimensions are shown in Fig. 3. Assemble and install accessory roof curb in accordance with instructions shipped with the curb.

NOTE:The gasketing of the unit to the roof curb is critical for a watertight seal. Install gasket supplied with the roof curb as shown in Fig. 3. Improperly applied gasket can also result in air leaks and poor unit performance.

Curb should be level. This is necessary for unit drain to function properly. Unit leveling tolerances are show in Fig. 4. Refer to Accessory Roof Curb Installation Instructions for additional information as required.

Install insulation, cant strips, roofing felt, and counter flashing as shown. *Ductwork must be attached to curb and not to the unit. The accessory thru-the-base power and gas connection package must be installed before the unit is set on the roof curb.* If field-installed thru-the-roof curb gas connections are desired, use factory-supplied 1/2-in. pipe coupling and gas plate assembly to mount the thru-the-roof curb connection to the roof curb. Gas connections and power connections to the unit must be field installed after the unit is installed on the roof curb.

If electric and control wiring is to be routed through the basepan, attach the accessory thru-the-base service connections to the basepan in accordance with the accessory installation instructions.

Slab Mount (Horizontal Units Only) —

Provide a level concrete slab that extends a minimum of 6 in. (150 mm) beyond unit cabinet. Install a gravel apron in front of condenser coil air inlet to prevent grass and foliage from obstructing airflow.

NOTE:Horizontal units may be installed on a roof curb if required.

Alternate Unit Support (In Lieu of Curb or Slab Mount) —

A non-combustible sleeper rail can be used in the unit curb support area. If sleeper rails cannot be used, support the long sides of the unit with a minimum of three equally spaced 4-in. x 4-in. (102 mm x 102 mm) pads on each side.

FIGURE 4

Roof Curb Details

| | | | | |
|---------------------|---------------------|----------------------|------------------------|---|
| CONNECTOR PKG. ACC. | GAS CONNECTION TYPE | POWER WIRING FITTING | CONTROL WIRING FITTING | ACCESSORY CONVENIENCE OUTLET WIRING CONNECTOR |
| CRBTMPWR002A01 | THRU THE CURBS | 1 1/4" [31.7] NPT | 1/2" [12.7] NPT | 1/2" [12.7] NPT |
| CRBTMPWR004A01 | THRU THE BOTTOM | | | |

- NOTES:
 1. ROOFCURB ACCESSORY IS SHIPPED DISASSEMBLED.
 2. MATERIAL IS POLYURETHANE FOAM, 44.5 [1.34] # DENSITY.
 3. DIMENSIONS IN [] ARE IN MILLIMETERS.
 4. ROOFCURB: 18 GAGE STEEL.
 5. ATTACH DUCTWORK TO CURB. (FLANGES OF DUCT REST ON CURB).
 6. SERVICE CLEARANCE 4 FEET ON EACH SIDE.
 7. CONNECTOR PACKAGE CRBTMPWR002A01 IS FOR THRU-THE-CURB GAS TYPE.
 8. CONNECTOR PACKAGE CRBTMPWR004A01 IS FOR THRU-THE-BOTTOM TYPE GAS CONNECTIONS.

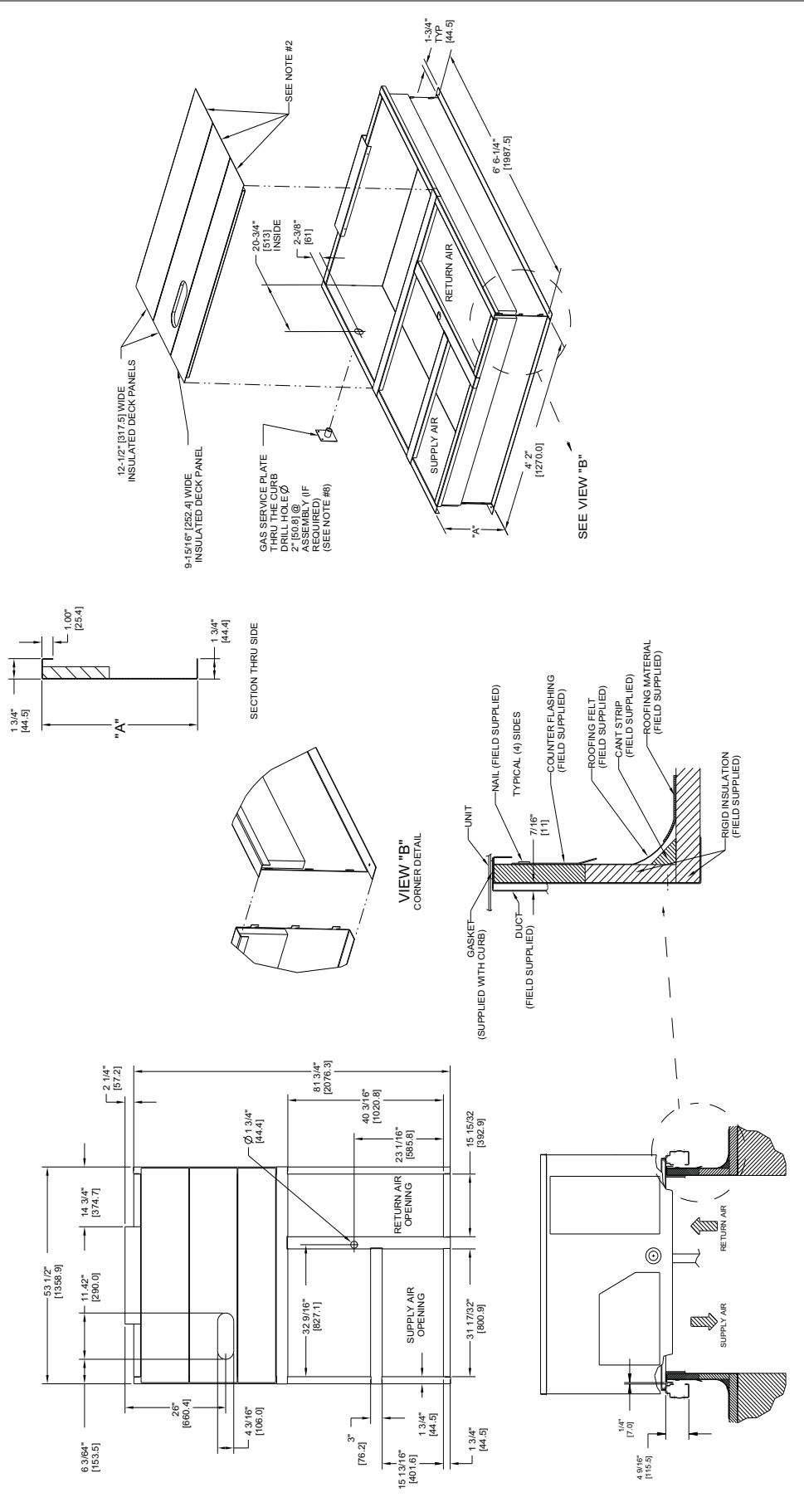

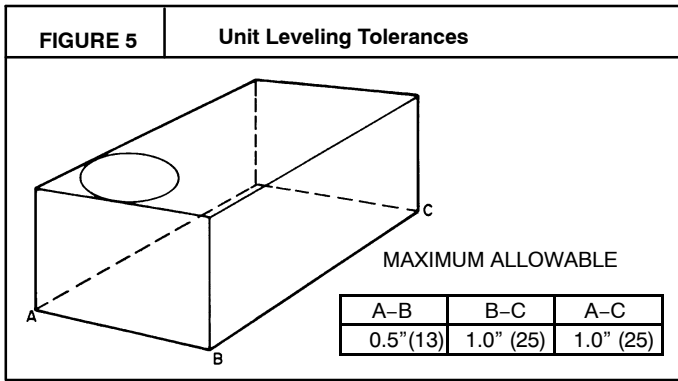

Step 5 — Field Fabricate Ductwork

Cabinet return-air static pressure (a negative condition) shall not exceed 0.35 in. wg (87 Pa) with economizer or 0.45 in. wg (112 Pa) without economizer.

For vertical ducted applications, secure all ducts to roof curb and building structure. *Do not connect ductwork to unit.*

Insulate and weatherproof all external ductwork, joints, and roof openings with counter flashing and mastic in accordance with applicable codes.

Ducts passing through unconditioned spaces must be insulated and covered with a vapor barrier.

If a plenum return is used on a vertical unit, the return should be ducted through the roof deck to comply with applicable fire codes.

A minimum clearance is not required around ductwork.

Step 6 — Rig and Place Unit

Keep unit upright and do not drop. Spreader bars are not required if top crating is left on unit. Rollers may be used to move unit across a roof. Level by using unit frame as a reference. See Table 1 and Fig. 5 for additional information.

Lifting holes are provided in base rails as shown in Fig. 5. Refer to rigging instructions on unit.

| |
|--|
| ⚠ CAUTION |
| UNIT DAMAGE HAZARD |
| Failure to follow this caution may result in equipment damage. |
| All panels must be in place when rigging. Unit is not designed for handling by fork truck. |

Before setting the unit onto the curb, recheck gasketing on curb.

Positioning on Curb —

Position unit on roof curb so that the following clearances are maintained: 1/4 in. (6.4 mm) clearance between the roof curb and the base rail inside the front and rear, 0.0 in. clearance between the roof curb and the base rail inside on the duct end of the unit. This will result in the distance between the roof curb and the base rail inside on the condenser end of the unit being approximately equal to Fig. 3, section C-C.

Although unit is weatherproof, guard against water from higher level runoff and overhangs.

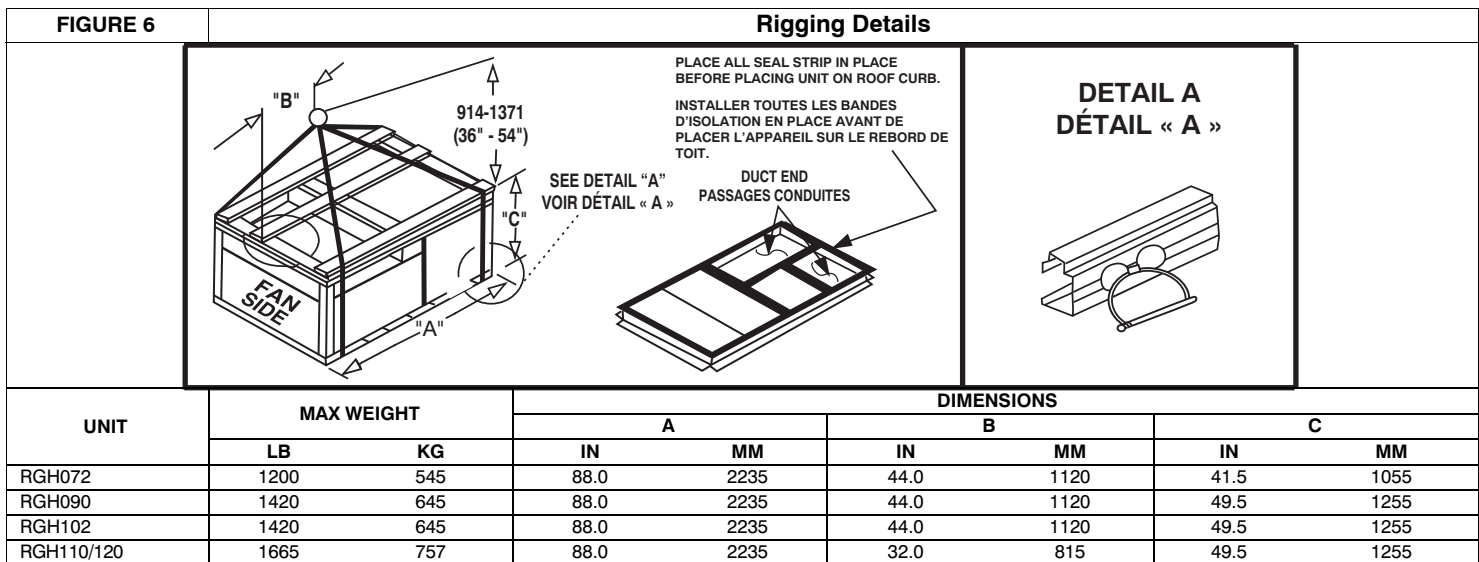

NOTES:

- Dimensions in () are in millimeters.
- Hook rigging shackles through holes in base rail, as shown in detail "A." Holes in base rails are centered around the unit center of gravity. Use wooden top to prevent rigging straps from damaging unit.
- Unit weights do not include economizer.

⚠ CAUTION

UNIT DAMAGE HAZARD

Failure to follow this caution may result in equipment damage.

All panels must be in place when rigging. Unit is not designed for handling by fork truck.

Flue vent discharge must have a minimum horizontal clearance of 4 ft (1220 mm) from electric and gas meters, gas regulators, and gas relief equipment. Minimum distance between unit and other electrically live parts is 48 inches (1220 mm).

Flue gas can deteriorate building materials. Orient unit such that flue gas will not affect building materials. Locate mechanical draft system flue assembly at least 48 in. (1220 mm) from an adjacent building or combustible material.

NOTE: Installation of accessory flue discharge deflector kit will reduce the minimum clearance to combustible material to 18 in. (460 mm).

After unit is in position, remove rigging skids and shipping materials.

Step 7 — Convert to Horizontal and Connect Ductwork (when required)

Unit is shipped in the vertical duct configuration. Unit *without* factory-installed economizer or return air smoke detector option may be field-converted to horizontal ducted configuration. To convert to horizontal configuration, remove screws from side duct opening covers and remove covers. Using the same screws, install covers on vertical duct openings with the insulation-side down. Seals around duct openings must be tight. See Fig. 6.

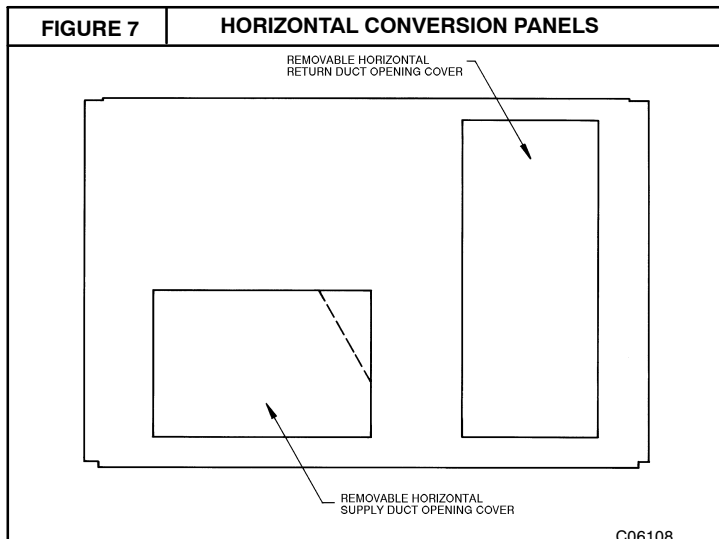

Field-supplied flanges should be attached to horizontal duct openings and all ductwork should be secured to the flanges. Insulate and weatherproof all external ductwork, joints, and roof or building openings with counter flashing and mastic in accordance with applicable codes.

Do not cover or obscure visibility to the unit's informative data plate when insulating horizontal ductwork.

Step 8 — Install Optional Outside Air Hood Economizer Hood Removal and Setup – Factory Option

1. The hood is shipped in a box located in the unit return air compartment behind the outdoor-air opening access panel (or economizer).
2. To gain access to the hood, remove the filter access panel. (See Fig. 7.)
3. Locate and cut the (2) plastic tie-wraps, being careful to not damage any wiring. (See Fig. 8.)
4. Carefully lift the hood assembly through the filter access opening and assemble per the steps outlined in Economizer Hood and Two-Position Hood.

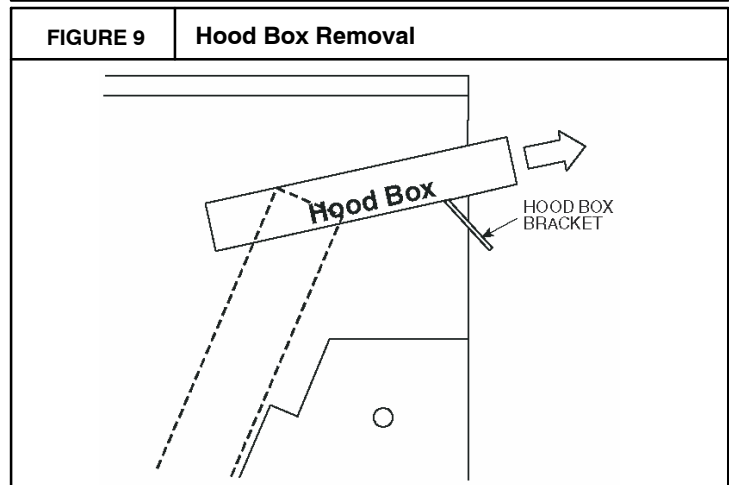
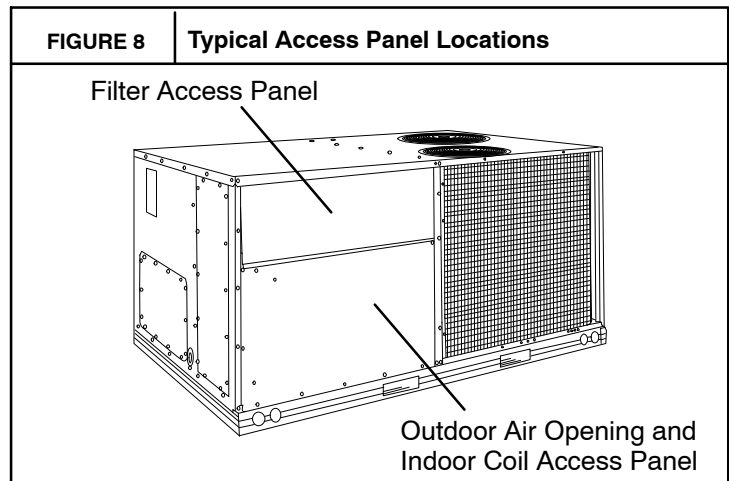

Two Position Damper Hood Removal and Setup — Factory Option

1. The hood is shipped in knock-down form and assembled to a metal support tray using plastic stretch wrap. Located in the return air compartment, the assembly's metal tray is attached to the basepan and also attached to the damper using two plastic tie-wraps.
2. To gain access to the hood, remove the filter access panel. See Fig. 7.
3. Locate the (2) screws holding the metal tray to the basepan and remove. Locate and cut the (2) plastic tie-wraps securing the assembly to the damper. (See Fig. 9.) Be careful to not damage any wiring or cut tie-wraps securing any wiring.

- Carefully lift the hood assembly (with metal tray) through the filter access opening and assemble per the steps outlined in Economizer Hood and Two-Position Hood.

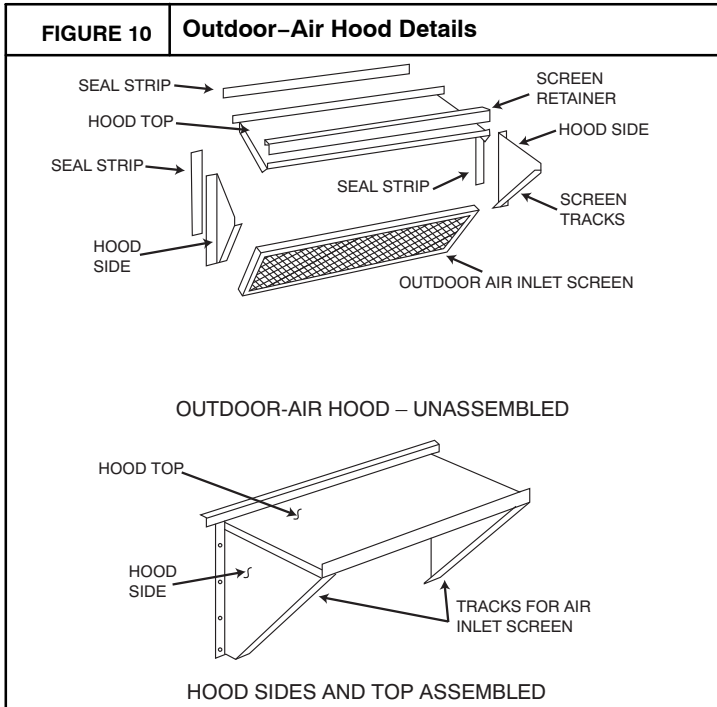

Economizer Hood and Two-Position Damper Hood (Optional) —

NOTE: If the power exhaust accessory is to be installed on the unit, the hood shipped with the unit will not be used and must be discarded. Save the aluminum filter for use in the power exhaust hood assembly.

- The indoor coil access panel will be used as the top of the hood. Remove the screws along the sides and bottom of the indoor coil access panel. See Fig. 10.

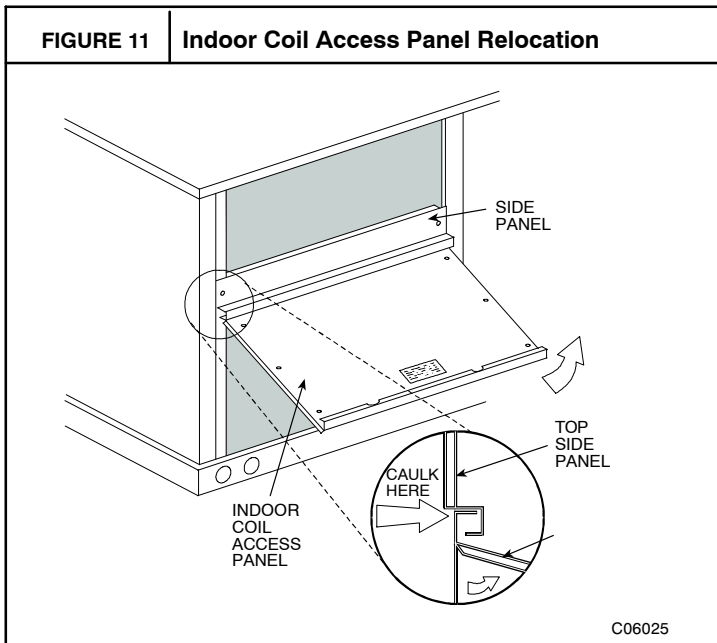

- Swing out indoor coil access panel and insert the hood sides under the panel (hood top). Use the screws provided to attach the hood sides to the hood top. Use screws provided to attach the hood sides to the unit. See Fig. 11.

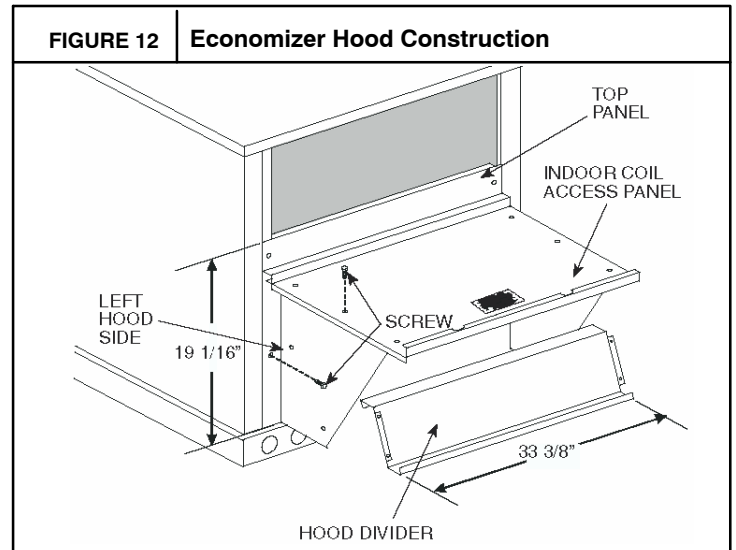

- Remove the shipping tape holding the economizer barometric relief damper in place.
- Insert the hood divider between the hood sides. See Fig. 11 and 12. Secure hood divider with 2 screws on each hood side. The hood divider is also used as the bottom filter rack for the aluminum filter.
- Open the filter clips which are located underneath the hood top. Insert the aluminum filter into the bottom filter rack (hood divider). Push the filter into position past the open filter clips. Close the filter clips to lock the filter into place. See Fig. 12.

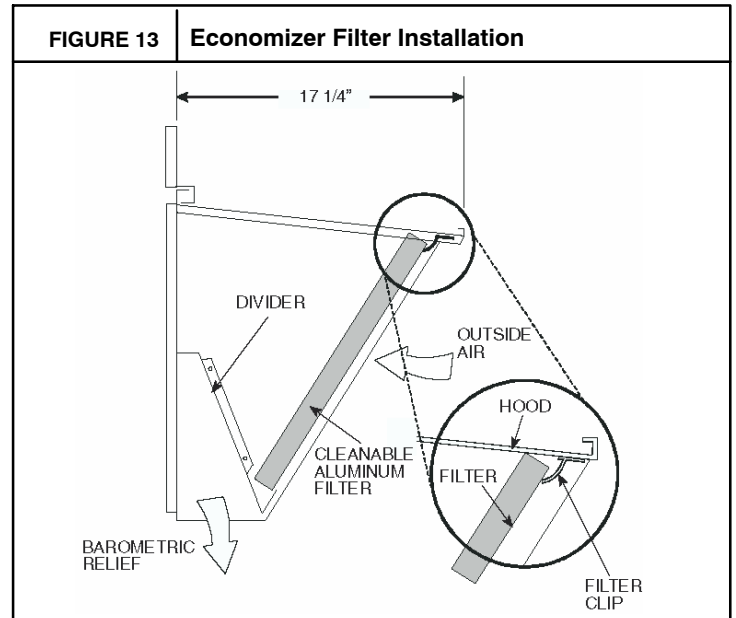

- Caulk the ends of the joint between the unit top panel and the hood top.
- Replace the filter access panel.

Step 9 — Install Flue Hood

Flue hood is shipped screwed to the basepan beside the burner compartment access panel. Remove from shipping location and using screws provided, install flue hood and screen in location shown in Fig. 13.

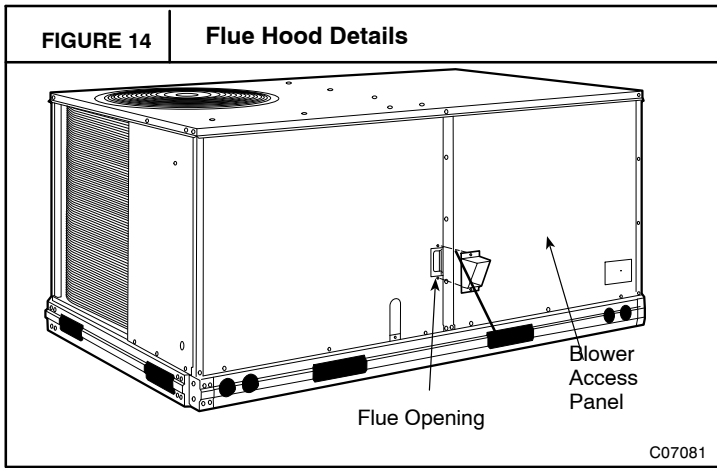

Step 10 — Install Gas Piping

Installation of the gas piping must be accordance with local building codes and with applicable national codes. In U.S.A., refer to NFPA 54/ANSI Z223.1 National Fuel Gas Code (NFGC). In Canada, installation must be accordance with the CAN/CSA B149.1 and CAN/CSA B149.2 installation codes for gas burning appliances.

This unit is factory equipped for use with Natural Gas fuel at elevations up to 2000 ft (610 m) above sea level. Unit may be field converted for operation at elevations above 2000 ft (610 m) and/or for use with liquefied petroleum fuel. See accessory kit installation instructions regarding these accessories.

NOTE: Furnace gas input rate on rating plate is for installation up to 2000 ft (610 m) above sea level. In U.S.A. the input rating for altitudes above 2000 ft (610 m) must be derated by 4% for each 1000 ft (305 m) above sea level. In Canada the input rating must be derated by 10% for altitudes of 2000 ft (610 m) to 4500 ft (1372 m) above sea level.

For natural gas applications, gas pressure at unit gas connection must not be less than 4 in. wg (996 Pa) or greater than 13 in. wg (3240 Pa) while the unit is operating. For liquified petroleum applications, the gas pressure must not be less than 11 in. wg (2740 Pa) or greater than 13 in. wg (3240 Pa) at the unit connection.

Table 2—Natural Gas Supply Line Pressure Ranges

| UNIT MODEL | UNIT SIZE | MIN | MAX |
|------------|-------------------------|---------------------|-----------------------|
| RGH | 072, 090, 102, 110, 120 | 4.0 in. wg (996 Pa) | 13.0 in. wg (3240 Pa) |

Table 3—Liquid Propane Supply Line Pressure Ranges

| UNIT MODEL | UNIT SIZE | MIN | MAX |
|------------|-------------------------|-----------------------|-----------------------|
| RGH | 072, 090, 102, 110, 120 | 11.0 in. wg (2740 Pa) | 13.0 in. wg (3240 Pa) |

The gas supply pipe enters the unit at the burner access panel on the front side of the unit, through the long slot at the bottom of the access panel. The gas connection to the unit is made to the 1/2-in. or 3/4-in. FPT gas inlet port on the unit gas valve.

Manifold pressure is factory-adjusted for NG fuel use. Adjust as required to obtain best flame characteristics.

Table 4—Natural Gas Manifold Pressure Ranges

| UNIT MODEL | UNIT SIZE | HIGH FIRE | LOW FIRE [‡] |
|------------|-------------------------|---------------------|-----------------------|
| RGH | 072, 090, 102, 110, 120 | 3.5 in. wg (872 Pa) | 2.0 in. wg (498 Pa) |

[‡]**NOTE—** LOW FIRE, 1.7 in. Wg (423 Pa), applies to the following units only: RGH072*D/S, RGH090*D/S & RGH102*D/S

Manifold pressure for LP fuel use must be adjusted to specified range. Follow instructions in the accessory kit to make initial readjustment.

Table 5—Liquid Propane Manifold Pressure Ranges

| UNIT MODEL | UNIT SIZE | HIGH FIRE | LOW FIRE [‡] |
|------------|-------------------------|-----------------------|-----------------------|
| RGH | 072, 090, 102, 110, 120 | 10.0 in. wg (2490 Pa) | 5.7 in. wg (1420 Pa) |

[‡]**NOTE—** LOW FIRE, 5.0 in. Wg (1420 Pa), applies to the following units only: RGH072*D/S, RGH090*D/S & RGH102*D/S

⚠ CAUTION

EQUIPMENT DAMAGE HAZARD

Failure to follow this caution may result in damage to equipment.

When connecting the gas line to the unit gas valve, the installer **MUST** use a backup wrench to prevent damage to the valve.

Install a gas supply line that runs to the unit heating section. Refer to the NFPA 54/NFGC or equivalent code for gas pipe sizing data. Do not use a pipe smaller than 1/2-in. Size the gas supply line to allow for a maximum pressure drop of 0.5-in wg (124 Pa) between gas regulator source and unit gas valve connection when unit is operating at high-fire flow rate.

The gas supply line can approach the unit in three ways: horizontally from outside the unit (across the roof), thru-curb/under unit basepan (accessory kit required) or through unit basepan (factory-option or accessory kit required). Consult accessory kit installation instructions for details on these installation methods.

Optional Thru-Base Connections —

This accessory (field installed) service connection kit consists of a 1/2-in electrical bulkhead and a 3/4-in electrical bulkhead connector, all factory installed in the embossed (raised) section of the unit basepan in the condenser section.

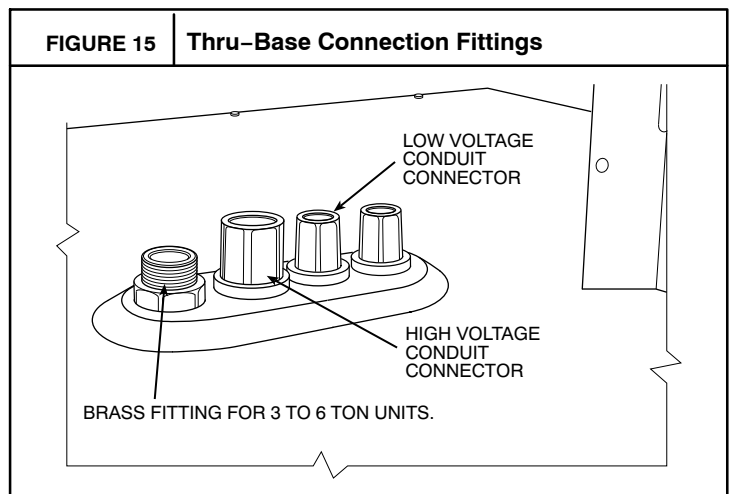

The thru-base gas connector has male and female threads. The male threads protrude above the basepan of the unit; the female threads protrude below the basepan.

Check tightness of connector lock nuts before connecting gas piping.

Gas Line: Install a 1/2-in NPT street elbow on the thru-base gas fitting. Attach 1/2-in nipple with minimum length of 16-in (406 mm) (field-supplied) to the street elbow and extend it through the access panel at the gas support bracket. See Fig. 15.

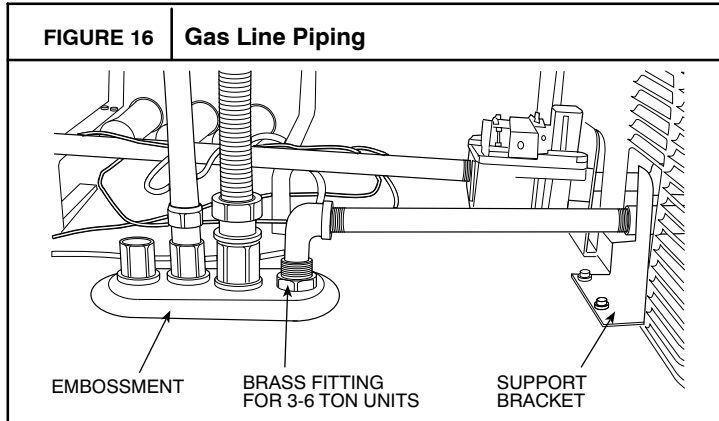

Other hardware required to complete the installation of the gas supply line will include a manual shutoff valve, a sediment trap (drip leg) and a ground-joint union. A pressure regulator valve may also be required (to convert gas pressure from pounds to inches of pressure). The manual shutoff valve must be located within 6-ft (1.83 m) of the unit. The union, located in the final leg entering the unit, must be located at least 9-in (230 mm) away from the access panel to permit the panel to be removed for service. If a regulator valve is installed, it must be located a minimum of 4-ft (1220 mm) away from the unit's flue outlet. Some municipal codes require that the manual shutoff valve be located upstream of the sediment trap. See Figures 16 and 17 for typical piping arrangements for gas piping that has been routed through the sidewall of the curb. See Fig. 18 for typical piping arrangement when thru-base is used. Ensure that all piping does not block access to the unit's main control box or limit the required working space in front of the control box.

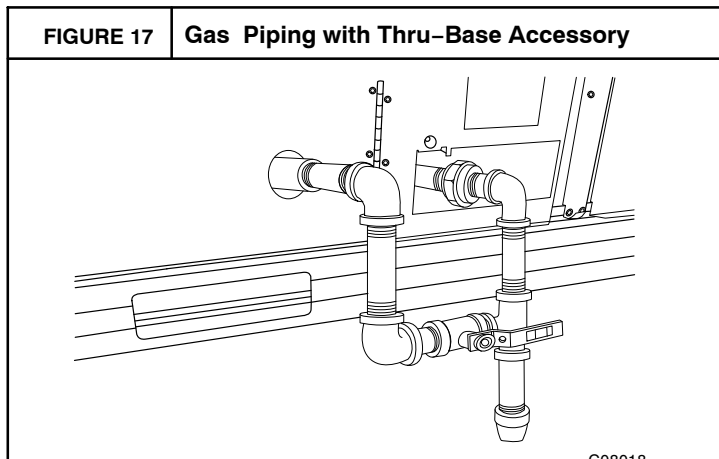

When installing the gas supply line, observe local codes pertaining to gas pipe installations. Refer to the NFPA 54/ANSI Z223.1 NFGC latest edition (in Canada, CAN/CSA

B149.1). In the absence of local building codes, adhere to the following pertinent recommendations:

1. Avoid low spots in long runs of pipe. Grade all pipe 1/4-in. in every 15 ft (7 mm in every 5 m) to prevent traps. Grade all horizontal runs downward to risers. Use risers to connect to heating section and to meter.

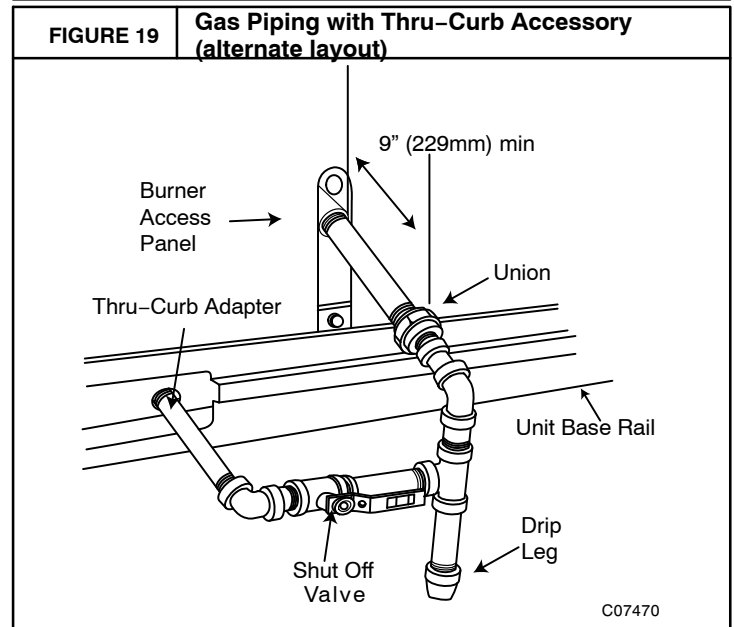
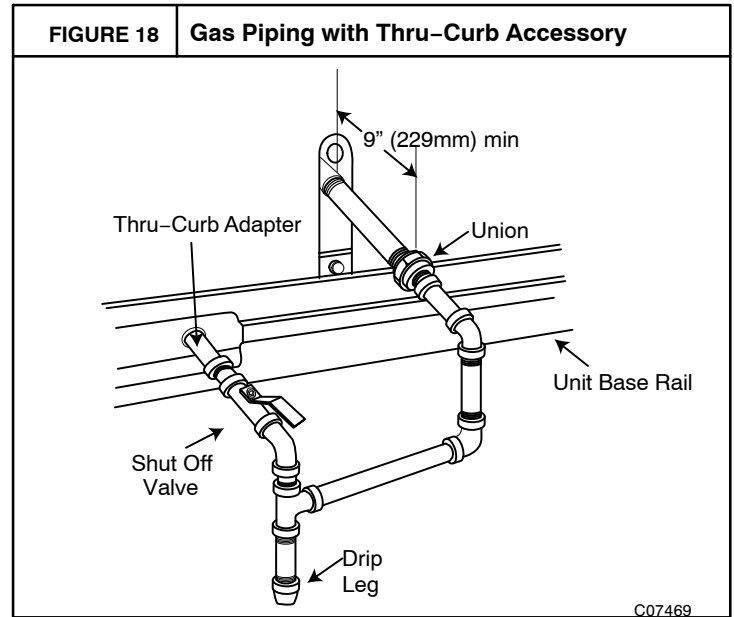

2. Protect all segments of piping system against physical and thermal damage. Support all piping with appropriate straps, hangers, etc. Use a minimum of one hanger every 6 ft (1.8 m). For pipe sizes larger than 1/2-in., follow recommendations of national codes.
3. Apply joint compound (pipe dope) sparingly and only to male threads of joint when making pipe connections. Use only pipe dope that is resistant to action of liquefied petroleum gases as specified by local and/or national codes. If using PTFE (Teflon) tape, ensure the material is Double Density type and is labeled for use on gas lines. Apply tape per manufacturer's instructions.
4. Pressure-test all gas piping in accordance with local and national plumbing and gas codes before connecting piping to unit.

NOTE: Pressure test the gas supply system after the gas supply piping is connected to the gas valve. The supply piping must be disconnected from the gas valve during the testing of the piping systems when test pressure is in excess of 0.5 psig (3450 Pa). Pressure test the gas supply piping system at pressures equal to or less than 0.5 psig (3450 Pa). The unit heating section must be isolated from the gas piping system by closing the external main manual shutoff valve and slightly opening the ground-joint union.

Check for gas leaks at the field-installed and factory-installed gas lines after all piping connections have been completed. Use soap-and-water solution (or method specified by local codes and/or regulations).

⚠ WARNING

FIRE OR EXPLOSION HAZARD

Failure to follow this warning could result in personal injury, death and/or property damage.

- Connect gas pipe to unit using a backup wrench to avoid damaging gas controls.
- Never purge a gas line into a combustion chamber.
- Never test for gas leaks with an open flame. Use a commercially available soap solution made specifically for the detection of leaks to check all connections.
- Use proper length of pipe to avoid stress on gas control manifold.

NOTE: If orifice hole appears damaged or it is suspected to have been redrilled, check orifice hole with a numbered drill bit of correct size. Never redrill an orifice. A burr-free and squarely aligned orifice hole is essential for proper flame characteristics.

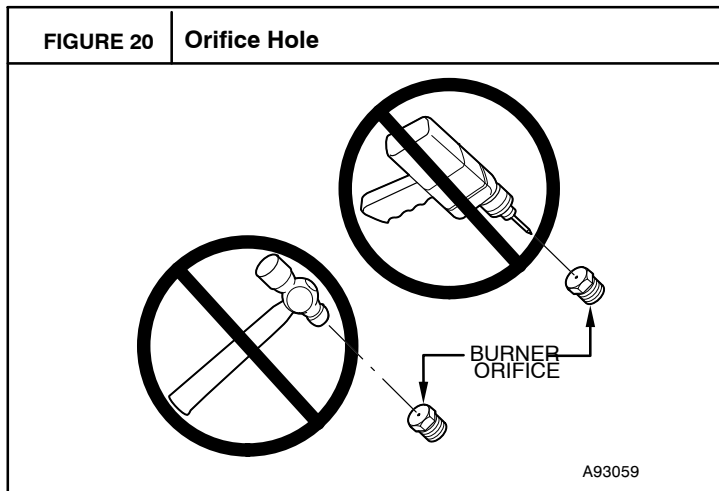

Step 11 — Install External Condensate Trap and Line

The unit has one $\frac{3}{4}$ -in. condensate drain connection on the end of the condensate pan and an alternate connection on the bottom. See Fig. 20. Unit airflow configuration does not determine which drain connection to use. Either drain connection can be used with vertical or horizontal applications.

When using the standard side drain connection, ensure the red plug in the alternate bottom connection is tight. Do this

before setting the unit in place. The red drain pan can be tightened with a $\frac{1}{2}$ -in. square socket drive extension.

To use the alternate bottom drain connection, remove the red drain plug from the bottom connection (use a $\frac{1}{2}$ -in. square socket drive extension) and install it in the side drain connection.

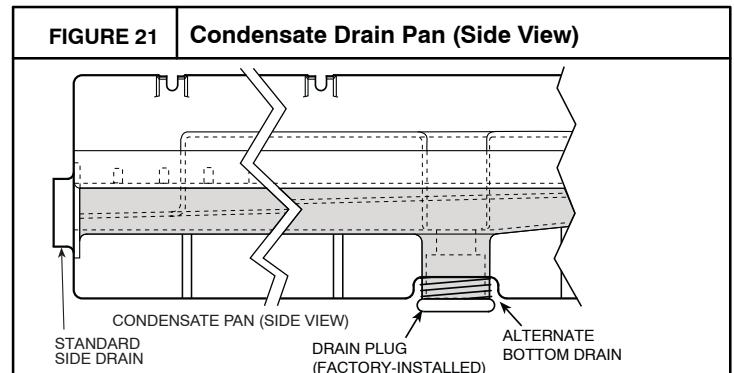

The piping for the condensate drain and external trap can be completed after the unit is in place. See Fig. 21.

All units must have an external trap for condensate drainage. Install a trap at least 4-in. (102 mm) deep and protect against freeze-up. If drain line is installed downstream from the external trap, pitch the line away from the unit at 1-in. per 10 ft (25 mm in 3 m) of run. Do not use a pipe size smaller than the unit connection ($\frac{3}{4}$ -in.).

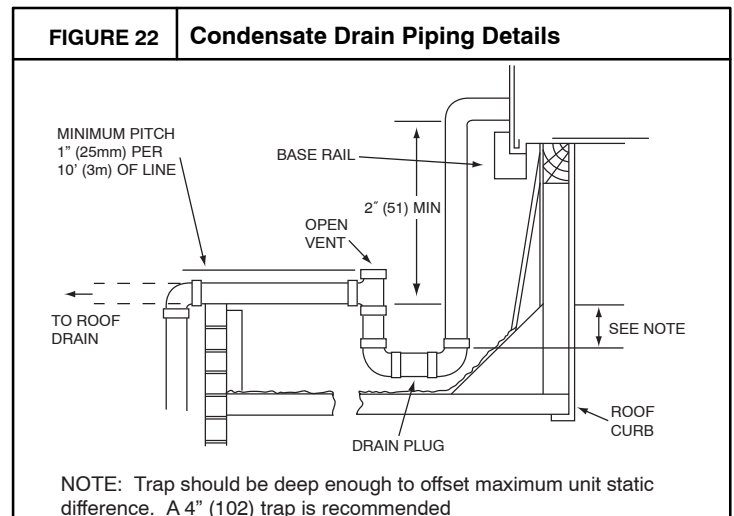

Step 12 — Make Electrical Connections

⚠ WARNING

ELECTRICAL SHOCK HAZARD

Failure to follow this warning could result in personal injury or death.

Do not use gas piping as an electrical ground. Unit cabinet must have an uninterrupted, unbroken electrical ground to minimize the possibility of personal injury if an electrical fault should occur. This ground may consist of electrical wire connected to unit ground lug in control compartment, or conduit approved for electrical ground when installed in accordance with NEC (National Electrical Code); ANSI/NFPA 70, latest edition (in Canada, Canadian Electrical Code CSA [Canadian Standards Association] C22.1), and local electrical codes.

Field Power Supply —

Field power wires are connected to the unit at line-side pressure lugs on compressor contactor C and indoor fan contactor IFC (see wiring diagram label for control box component arrangement) or at factory-installed option non-fused disconnect switch. Max wire size is #2 AWG (copper only).

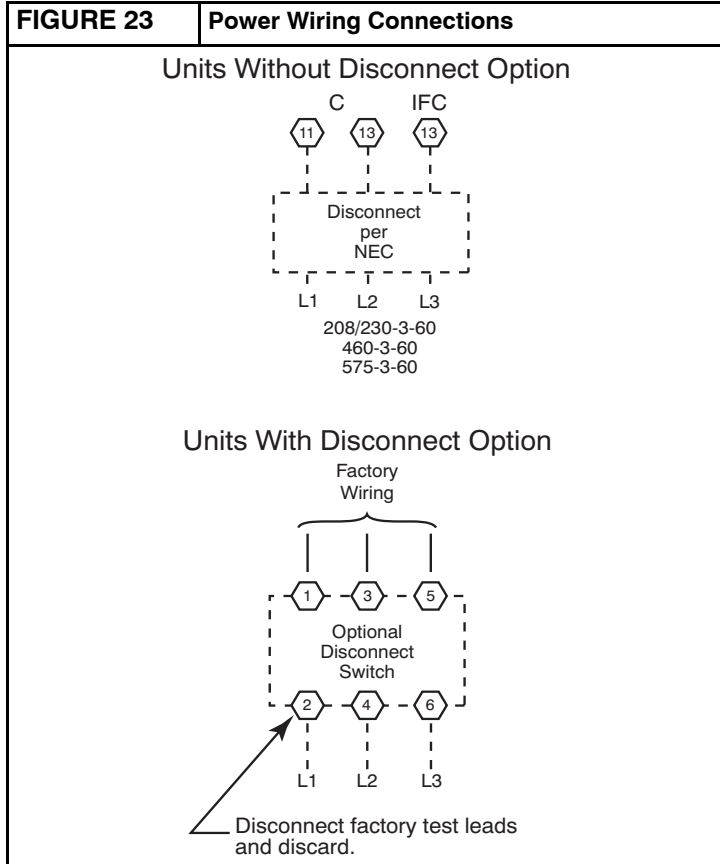

NOTE:TEST LEADS – Unit may be equipped with short leads (pigtailed) on the field line connection points on contactor C or optional disconnect switch. These leads are for factory run-test purposes only; remove and discard before connecting field power wires to unit connection points. Make field power connections directly to line connection pressure lugs only.

Units with Factory-Installed Disconnect —

The factory-installed option disconnect switch is located in a weatherproof enclosure located under the main control box. The manual switch handle is accessible through an opening in the access panel. (See Fig. 22)

⚠ WARNING

FIRE HAZARD

Failure to follow this warning could result in intermittent operation or performance satisfaction.

Do not connect aluminum wire between disconnect switch and furnace. Use only copper wire.

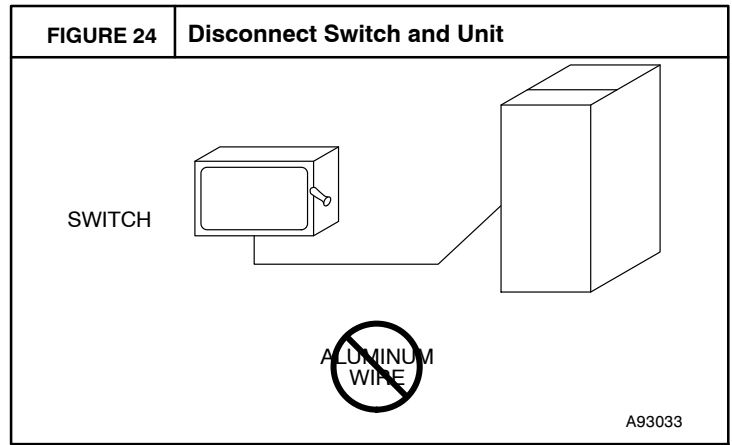

Units Without Factory-Installed Disconnect —

When installing units, provide a disconnect switch per NEC (National Electrical Code) of adequate size. Disconnect sizing data is provided on the unit informative plate. Locate on unit cabinet or within sight of the unit per national or local codes. Do not cover unit informative plate if mounting the disconnect on the unit cabinet.

All units –

All field wiring must comply with NEC and all local codes. Size wire based on MCA (Minimum Circuit Amps) on the unit informative plate. See Fig. 21 for power wiring connections to the unit power terminal block and equipment ground. Maximum wire size is #2 ga AWG per pole.

Provide a ground-fault and short-circuit over-current protection device (fuse or breaker) per NEC Article 440 (or local codes). Refer to unit informative data plate for MOCP (Maximum Over-current Protection) device size.

All field wiring must comply with the NEC and local requirements.

All units except 208/230-v units are factory wired for the voltage shown on the nameplate. *If the 208/230-v unit is to be connected to a 208-v power supply, the control transformer must be rewired by moving the black wire with the 1/4-in. female spade connector from the 230-v connection and moving it to the 200-v 1/4-in. male terminal on the primary side of the transformer.* Refer to unit label diagram for additional information. Field power wires will be connected line-side pressure lugs on the power terminal block or at factory-installed option non-fused disconnect.

NOTE:Check all factory and field electrical connections for tightness. Field-supplied wiring shall conform with the limitations of 63°F (33°C) rise.

Convenience Outlets —

⚠ WARNING

ELECTRICAL OPERATION HAZARD

Failure to follow this warning could result in personal injury or death.

Units with convenience outlet circuits may use multiple disconnects. Check convenience outlet for power status before opening unit for service. Locate its disconnect switch, if appropriate, and open it. Tag-out this switch, if necessary.

An optional non-powered convenience outlet is offered on RGH models that provide a 125-volt GFCI (ground-fault circuit-interrupter) duplex receptacle rated at 15-A behind a hinged access cover, located on the corner panel of the unit. See Fig. 24.

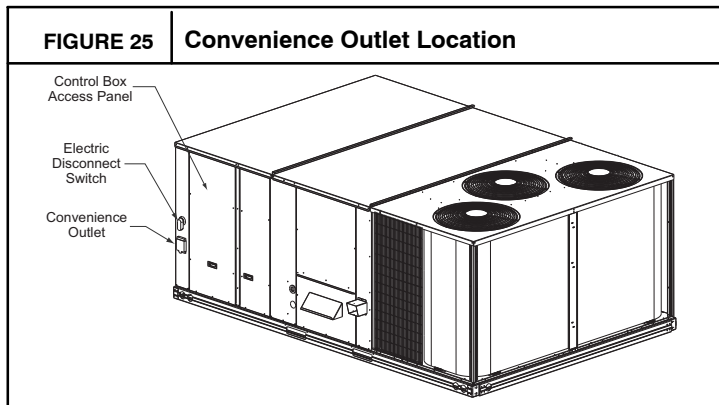

Installing Weatherproof Cover —

A weatherproof while-in-use cover for the factory-installed convenience outlets is now required by UL standards. This cover cannot be factory-mounted due its depth; it must be installed at unit installation. For shipment, the convenience outlet is covered with a blank cover plate.

The weatherproof cover kit is shipped in the unit's control box. The kit includes the hinged cover, a backing plate and gasket.

DISCONNECT ALL POWER TO UNIT AND CONVENIENCE OUTLET.

Remove the blank cover plate at the convenience outlet; discard the blank cover.

Loosen the two screws at the GFCI duplex outlet, until approximately 1/2-in (13 mm) under screw heads are exposed. Press the gasket over the screw heads. Slip the backing plate over the screw heads at the keyhole slots and align with the gasket; tighten the two screws until snug (do not over-tighten).

Mount the weatherproof cover to the backing plate as shown in Fig. 25. Remove two slot fillers in the bottom of the cover to permit service tool cords to exit the cover. Check for full closing and latching.

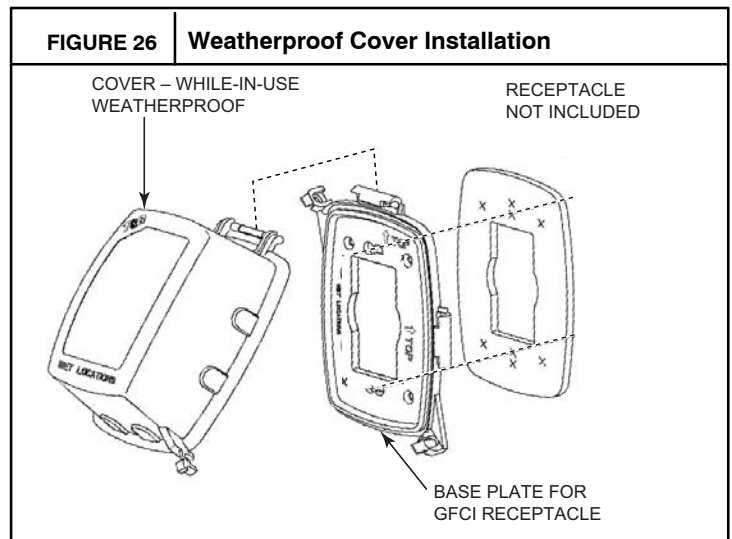

Non-powered type: This type requires the field installation of a general-purpose 125-volt 15-A circuit powered from a source elsewhere in the building. Observe national and local codes when selecting wire size, fuse or breaker requirements and disconnect switch size and location. Route 125-v power supply conductors into the bottom of the utility box containing the duplex receptacle.

Optional Thru-Base Connections —

This accessory (field installed) service connection kit consists of a 1/2-in NPT gas adapter fitting (brass), a 1/2-in electrical bulkhead connector and a 3/4-in electrical bulkhead connector, all must be installed in the embossed (raised) section of the unit basepan in the condenser section. The 3/4-in bulkhead connector enables the low-voltage control wires to pass through the basepan. The 1/2-in electrical bulkhead connector allows the high-voltage power wires to pass through the basepan. See Fig. 21.

Check tightness of connector lock nuts before connecting electrical conduits.

Field-supplied and field-installed liquid tight conduit connectors and conduit may be attached to the connectors on the basepan. Pull correctly rated high voltage and low voltage through appropriate conduits. Connect the power conduit to the internal disconnect (if unit is so equipped) or to the external disconnect (through unit side panel). A hole must be field cut in the main control box bottom on the left side so the 24-v control connections can be made. Connect the control power conduit to the unit control box at this hole.

Units without Thru-Base Connections —

1. Install power wiring conduit through side panel openings. Install conduit between disconnect and control box.
2. Install power lines to terminal connections as shown in Fig. 22.

Voltage to compressor terminals during operation must be within voltage range indicated on unit nameplate. See Table 2. On 3-phase units, voltages between phases must be

balanced within 2% and the current within 10%. Use the formula shown in the legend for Table 2, Note 2 to determine the percent of voltage imbalance. Operation on improper line voltage or excessive phase imbalance constitutes abuse and may cause damage to electrical components. Such operation would invalidate any applicable warranty.

Field Control Wiring —

The RGH unit requires an external temperature control device. This device typically applied with a commercial thermostat (field-supplied) with both occupied and unoccupied setpoints at a minimum.

Thermostat —

Install an approved accessory thermostat according to installation instructions included with the accessory. For complete economizer function, select a two-stage cooling thermostat. Locate the thermostat accessory on a solid wall in the conditioned space to sense average temperature in accordance with the thermostat installation instructions.

If the thermostat contains a logic circuit requiring 24-v power, use a thermostat cable or equivalent single leads of different colors with minimum of seven leads. If the thermostat does not require a 24-v source (no “C” connection required), use a thermostat cable or equivalent with minimum of six leads. Check the thermostat installation instructions for additional features which might require additional conductors in the cable.

Using unit-mounted convenience outlets: Units with unit-mounted convenience outlet circuits will often require that two disconnects be opened to de-energize all power to the unit. Treat all units as electrically energized until the convenience outlet power is also checked and de-energization is confirmed. Observe National Electrical Code Article 210, Branch Circuits, for use of convenience outlets.

For wire runs up to 50 ft. (15 m), use no. 18 AWG (American Wire Gage) insulated wire (35°C minimum). For 50 to 75 ft. (15 to 23 m), use no. 16 AWG insulated wire (35°C minimum). For over 75 ft. (23 m), use no. 14 AWG insulated wire (35°C minimum). All wire sizes larger than no. 18 AWG cannot be directly connected to the thermostat and will require a junction box and splice at the thermostat.

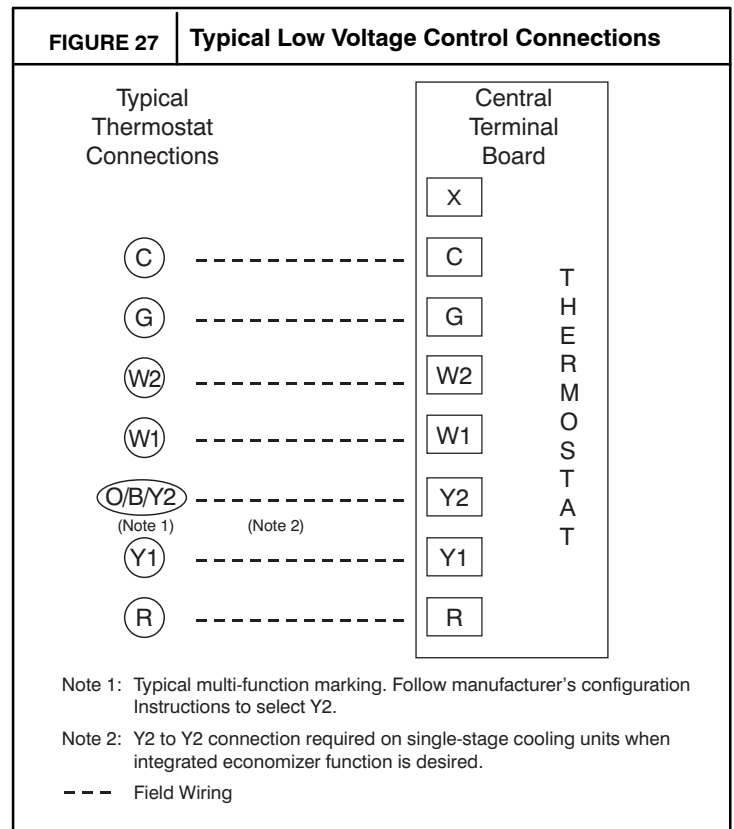

Unit without thru-base connection kit —

Pass the thermostat control wires through the hole provided in the corner post; then feed the wires through the raceway built into the corner post to the control box. Pull the wires over to the terminal strip on the upper-left corner of the Controls Connection Board. See Fig. 27.

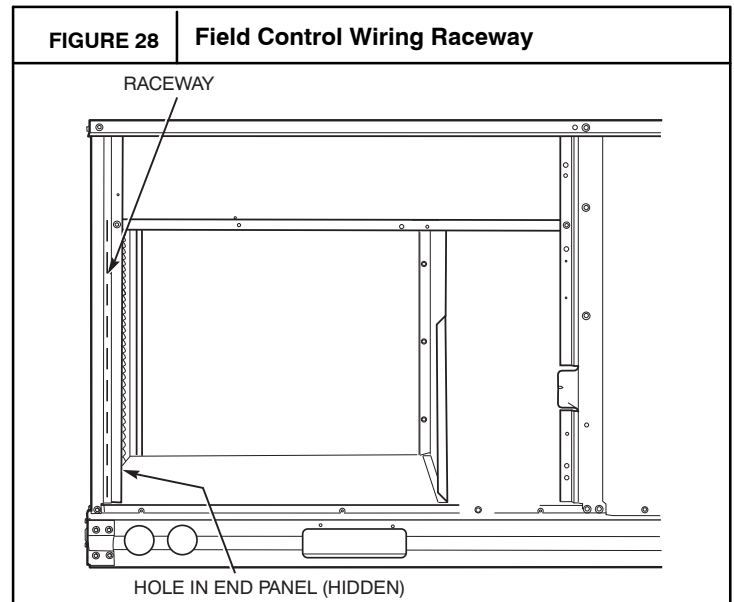

NOTE: If thru-the-bottom connections accessory is used, refer to the accessory installation instructions for information on routing power and control wiring.

Heat Anticipator Settings —

Set heat anticipator settings at 0.14 amp for the first stage and 0.14 amp for second-stage heating, when available.

SMOKE DETECTORS

Smoke detectors are available as factory-installed options on RGH models. Smoke detectors may be specified for Supply Air only. All components necessary for operation are factory-provided and mounted. The unit is factory-configured for immediate smoke detector shutdown operation; additional wiring or modifications to unit terminal board may be necessary to complete the unit and smoke detector configuration to meet project requirements.

System

The smoke detector system consists of a four-wire controller and one or two sensors. Its primary function is to shut down the rooftop unit in order to prevent smoke from circulating throughout the building. It is not to be used as a life saving device.

Controller

The controller (see Fig. 28) includes a controller housing, a printed circuit board, and a clear plastic cover. The controller can be connected to one or two compatible duct smoke sensors. The clear plastic cover is secured to the housing with a single captive screw for easy access to the wiring terminals. The controller has three LEDs (for Power, Trouble and Alarm) and a manual test/reset button (on the cover face).

Sensor

The sensor (see Fig. 29) includes a plastic housing, a printed circuit board, a clear plastic cover, a sampling tube inlet and an exhaust tube. The sampling tube (when used) and exhaust tube are attached during installation. The sampling tube varies in length depending on the size of the rooftop unit. The clear plastic cover permits visual inspections without having to disassemble the sensor. The cover attaches to the sensor housing using four captive screws and forms an airtight chamber around the sensing electronics. Each sensor includes a harness with an RJ45 terminal for connecting to the controller. Each sensor has four LEDs (for Power, Trouble, Alarm and Dirty) and a manual test/reset button (on the left-side of the housing).

Air is introduced to the duct smoke detector sensor's sensing chamber through a sampling tube that extends into the HVAC duct and is directed back into the ventilation system through a (shorter) exhaust tube. The difference in air pressure between the two tubes pulls the sampled air through the sensing chamber. When a sufficient amount of smoke is detected in the sensing chamber, the sensor signals an alarm state and the controller automatically takes the appropriate action to shut down fans and blowers, change over air handling systems, notify the fire alarm control panel, etc.

The sensor uses a process called differential sensing to prevent gradual environmental changes from triggering false alarms. A rapid change in environmental conditions, such as smoke from a fire, causes the sensor to signal an alarm state but dust and debris accumulated over time does not.

For installations using two sensors, the duct smoke detector does not differentiate which sensor signals an alarm or trouble condition.

FIGURE 29 Controller Assembly

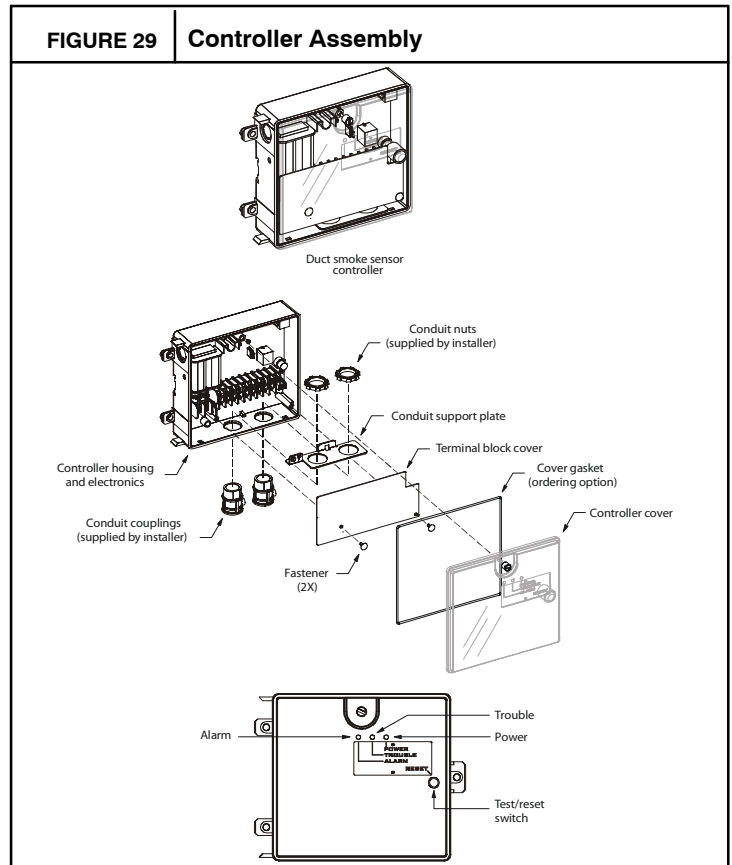
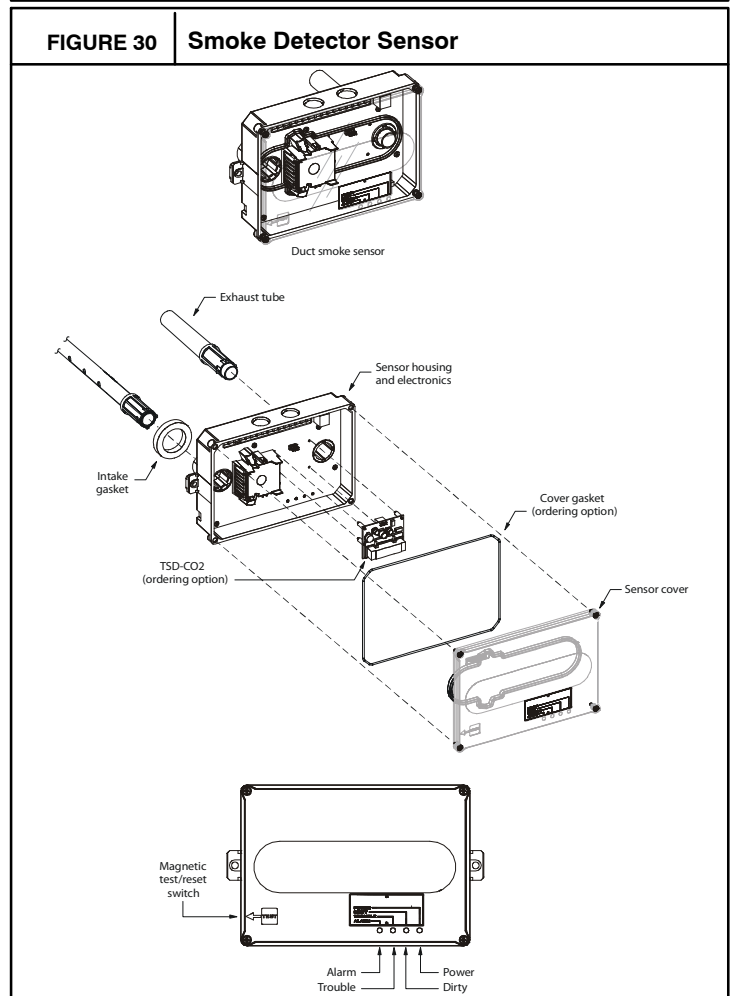
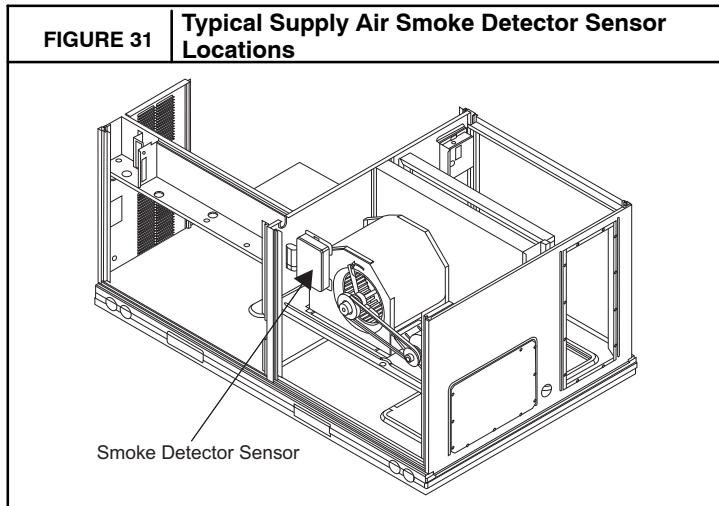

FIGURE 30 Smoke Detector Sensor



Smoke Detector Locations

Supply Air — The Supply Air smoke detector sensor is located to the left of the unit's indoor (supply) fan. See Fig. 30. Access is through the fan access panel. There is no sampling tube used at this location. The sampling tube inlet extends through the side plate of the fan housing (into a high pressure area). The controller is located on a bracket to the right of the return filter, accessed through the lift-off filter panel.



Hot Gas ReHeat Connections

Hot Gas ReHeat – Space RH Controller —

The Hot Gas ReHeat dehumidification system requires a field-supplied and -installed space relative humidity control device. This device may be a separate humidistat control (contact closes on rise in space RH above control setpoint) or a combination thermostat-humidistat control device with isolated contact set for dehumidification control. The humidistat is normally used in applications where a temperature control is already provided.

To connect the humidistat:

1. Route the humidistat 2-conductor cable (field-supplied) through the hole provided in the unit corner post.
2. Feed wires through the raceway built into the corner post (See FIGURE 28) to the 24-v barrier located on the left side of the control box. The raceway provides the UL-required clearance between high-voltage and low-voltage wiring.
3. Use wire nuts to connect humidistat cable to the leads in the low-voltage wiring (as shown in FIGURE 34), connecting PKN to PNK and PNK/BLK to PNK/BLK.

To connect the Thermidistat device:

1. Route the Thermidistat multi-conductor thermostat cable (field-supplied) through the hole provided in the unit corner post.
2. Feed wires through the raceway built into the corner post (See FIGURE 28) to the 24-v barrier located on the left

side of the control box. The raceway provides the UL-required clearance between high-voltage and low-voltage wiring.

3. The Thermidistat has dry contacts at terminals D1 and D2 for dehumidification operation (see FIGURE 35). The dry contacts must be wired between CTB terminal R and the PNK/BLK lead to the LTLO switch with field-supplied wire nuts. Refer to the installation instructions included with the Thermidistat device (Literature No. 50901350201, or later) for more information.

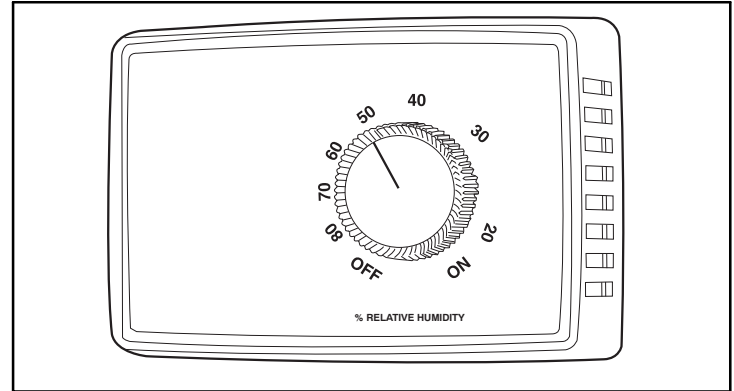

FIGURE 32 – Accessory Field-Installed Humidistat

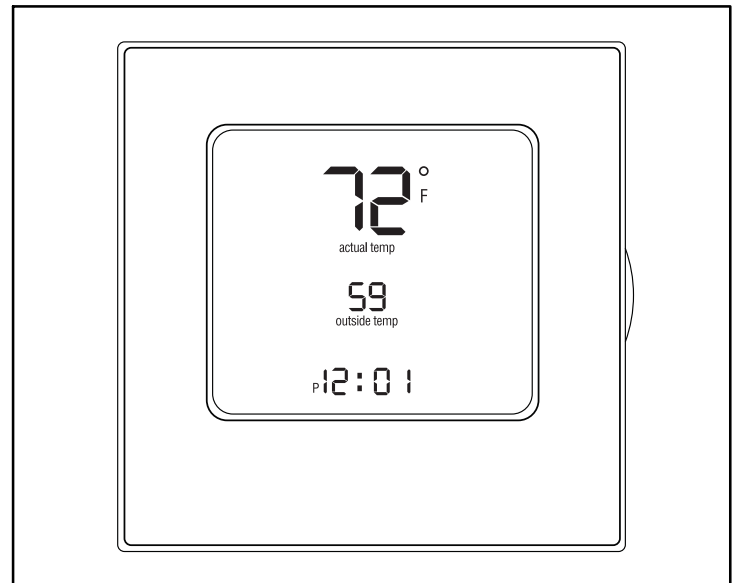

FIGURE 33 – Thermidistat

EconoMi\$er X (Factory-Installed Option) —

For details on operating RGS units equipped with the factory-installed EconoMi\$er X option, refer to *Factory-Installed Economizers for RGH/RAH/RHH/RGS/RAS /RHS Rooftop Units, 3 to 27.5 Nominal Tons. Economizer Supplement Related to California Title 24* (Literature No. 50901350201, or later).

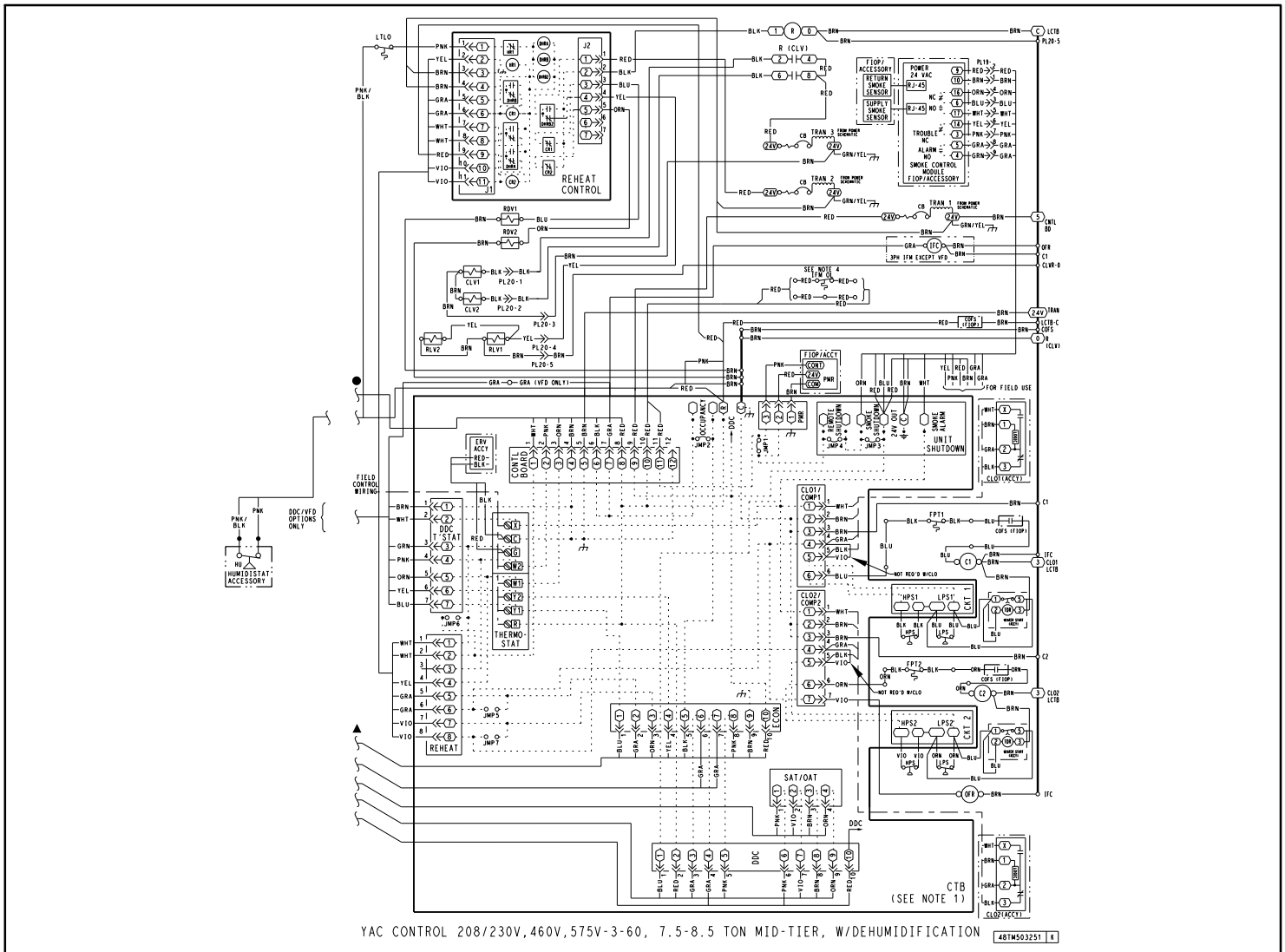

FIGURE 34 – Typical Hot Gas ReHeat Adaptive Dehumidification System Humidistat Wiring

C150047

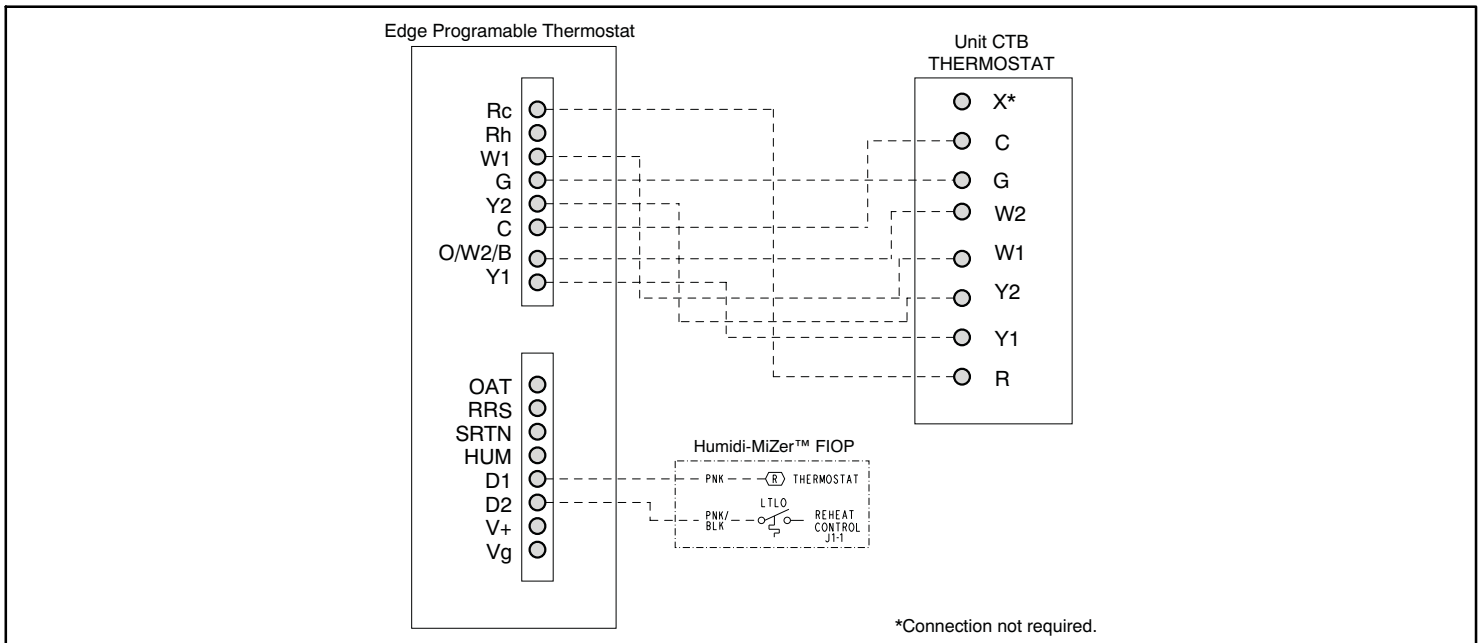

FIGURE 35 – Typical Rooftop Unit with Hot Gas ReHeat Adaptive Dehumidification System

C13066

Table 6—Unit Wire/Fuse or HACR Breaker Sizing Data – Single Speed Indoor Fan Motor

| UNIT | NOM.V–Ph–Hz | IFM TYPE | NO C.O. or UNPWR C.O. | | | | | | | |
|--|--------------|----------|-----------------------|-----------------------|------------|-----|-------------------------|-----------------------|------------|-----|
| | | | NO P.E. | | | | w/ P.E. (pwrd fr/ unit) | | | |
| | | | MCA | MAX FUSE or HACR BRKR | DISC. SIZE | | MCA | MAX FUSE or HACR BRKR | DISC. SIZE | |
| | | | MCA | MAX FUSE or HACR BRKR | FLA | LRA | MCA | MAX FUSE or HACR BRKR | FLA | LRA |
| RGH072 (1–stage cool) Units produced on or after 02/16/2015 | 208/230–3–60 | STD | 33/33 | 50/50 | 32/32 | 178 | 37/37 | 50/50 | 36/36 | 182 |
| | | MED | 36/36 | 50/50 | 36/36 | 214 | 40/40 | 50/50 | 40/40 | 218 |
| | | HIGH | 42/41 | 60/50 | 42/41 | 230 | 45/44 | 60/60 | 46/45 | 234 |
| | 460–3–60 | STD | 15 | 20 | 14 | 88 | 17 | 20 | 16 | 90 |
| | | MED | 17 | 20 | 16 | 106 | 18 | 25 | 18 | 108 |
| | | HIGH | 19 | 25 | 19 | 114 | 21 | 25 | 21 | 116 |
| | 575–3–60 | STD | 12 | 15 | 11 | 66 | 15 | 20 | 15 | 70 |
| | | MED | 13 | 15 | 12 | 81 | 17 | 20 | 17 | 85 |
| | | HIGH | 16 | 20 | 15 | 95 | 19 | 25 | 20 | 99 |
| RGH072 (1–stage cool) Units produced on or prior to 02/15/2015 | 208/230–3–60 | STD | 32/32 | 50/50 | 31/31 | 165 | 36/36 | 50/50 | 36/35 | 169 |
| | | MED | 36/36 | 50/50 | 35/35 | 201 | 39/39 | 50/50 | 39/39 | 205 |
| | | HIGH | 41/40 | 50/50 | 41/40 | 217 | 45/44 | 60/60 | 45/44 | 221 |
| | 460–3–60 | STD | 17 | 25 | 16 | 84 | 18 | 25 | 18 | 86 |
| | | MED | 18 | 25 | 18 | 102 | 20 | 25 | 20 | 104 |
| | | HIGH | 21 | 25 | 20 | 110 | 22 | 30 | 22 | 112 |
| | 575–3–60 | STD | 13 | 15 | 12 | 61 | 16 | 20 | 16 | 65 |
| | | MED | 14 | 20 | 13 | 76 | 18 | 20 | 17 | 80 |
| | | HIGH | 17 | 20 | 16 | 90 | 20 | 25 | 21 | 94 |
| RGH102 (2–stage cool) | 208/230–3–60 | STD | 39/39 | 50/50 | 41/40 | 208 | 43/43 | 50/50 | 45/45 | 212 |
| | | MED | 41/41 | 50/50 | 43/42 | 229 | 45/45 | 50/50 | 47/47 | 233 |
| | | HIGH | 45 | 50 | 47 | 258 | 48 | 60 | 51 | 262 |
| | 460–3–60 | STD | 18 | 20 | 19 | 104 | 20 | 25 | 21 | 106 |
| | | MED | 19 | 25 | 20 | 114 | 21 | 25 | 22 | 116 |
| | | HIGH | 21 | 25 | 22 | 129 | 23 | 25 | 24 | 131 |
| | 575–3–60 | STD | 13 | 15 | 13 | 77 | 17 | 20 | 17 | 81 |
| | | MED | 13 | 15 | 13 | 81 | 17 | 20 | 18 | 85 |
| | | HIGH | 14 | 15 | 14 | 92 | 18 | 20 | 19 | 96 |
| RGH102 (2–stage cool) | 208/230–3–60 | STD | 39/39 | 50/50 | 41/41 | 208 | 43/43 | 50/50 | 45/45 | 212 |
| | | MED | 41/41 | 50/50 | 43/43 | 229 | 45/45 | 50/50 | 47/47 | 233 |
| | | HIGH | 45 | 50 | 47 | 258 | 49 | 60 | 52 | 262 |
| | 460–3–60 | STD | 19 | 20 | 19 | 104 | 20 | 25 | 21 | 106 |
| | | MED | 19 | 25 | 20 | 114 | 21 | 25 | 22 | 116 |
| | | HIGH | 21 | 25 | 22 | 129 | 23 | 25 | 24 | 131 |
| | 575–3–60 | STD | 14 | 15 | 14 | 77 | 18 | 20 | 19 | 81 |
| | | MED | 14 | 20 | 15 | 81 | 18 | 20 | 19 | 85 |
| | | HIGH | 15 | 20 | 16 | 92 | 19 | 20 | 20 | 96 |
| RGH110 (2–stage cool) | 208/230–3–60 | STD | 51/50 | 60/60 | 53/53 | 284 | 54/54 | 60/60 | 57/57 | 288 |
| | | MED | 54 | 60 | 57 | 313 | 58 | 70 | 62 | 317 |
| | | HIGH | 57/56 | 70/60 | 61/60 | 315 | 61/60 | 70/70 | 65/64 | 319 |
| | 460–3–60 | STD | 23 | 25 | 24 | 136 | 25 | 30 | 26 | 138 |
| | | MED | 25 | 30 | 26 | 151 | 27 | 30 | 28 | 153 |
| | | HIGH | 26 | 30 | 28 | 152 | 28 | 30 | 30 | 154 |
| | 575–3–60 | STD | 18 | 20 | 18 | 95 | 21 | 25 | 23 | 99 |
| | | MED | 18 | 20 | 19 | 106 | 22 | 25 | 23 | 110 |
| | | HIGH | 21 | 25 | 22 | 120 | 25 | 30 | 27 | 124 |
| RGH120 (2–stage cool) | 208/230–3–60 | STD | 49/49 | 60/60 | 52/51 | 309 | 53/53 | 60/60 | 56/56 | 313 |
| | | MED | 53 | 60 | 56 | 338 | 57 | 70 | 60 | 342 |
| | | HIGH | 56/55 | 60/60 | 59/58 | 340 | 60/59 | 70/70 | 64/63 | 344 |
| | 460–3–60 | STD | 24 | 30 | 25 | 148 | 26 | 30 | 27 | 150 |
| | | MED | 26 | 30 | 27 | 163 | 28 | 30 | 29 | 165 |
| | | HIGH | 27 | 30 | 29 | 164 | 29 | 35 | 31 | 166 |
| | 575–3–60 | STD | 18 | 20 | 18 | 105 | 22 | 25 | 23 | 109 |
| | | MED | 19 | 20 | 19 | 116 | 22 | 25 | 24 | 120 |
| | | HIGH | 21 | 25 | 22 | 130 | 25 | 30 | 27 | 134 |

See "Legend and Notes for Tables 6 – 7 on page 22.

Table 7—Unit Wire/Fuse or HACR Breaker Sizing Data – Two Speed Indoor Fan Motor

| UNIT | NOM.V–Ph–Hz | IFM TYPE | NO C.O. or UNPWR C.O. | | | | | | | |
|--------------------------|--------------|----------|-----------------------|-----------------------|------------|-----|-------------------------|-----------------------|------------|-----|
| | | | NO P.E. | | | | w/ P.E. (pwrd fr/ unit) | | | |
| | | | MCA | MAX FUSE or HACR BRKR | DISC. SIZE | | MCA | MAX FUSE or HACR BRKR | DISC. SIZE | |
| | | | | | FLA | LRA | | | FLA | LRA |
| RGH072 (2–stage cool) | 208/230–3–60 | STD | 40/40 | 50/50 | 41/41 | 195 | 44/43 | 50/50 | 46/46 | 199 |
| | | MED | 41/41 | 50/50 | 43/43 | 199 | 45/45 | 50/50 | 47/47 | 203 |
| | | HIGH | 45/44 | 50/50 | 47/46 | 249 | 49/48 | 60/60 | 52/50 | 253 |
| | 460–3–60 | STD | 19 | 20 | 19 | 97 | 20 | 25 | 21 | 99 |
| | | MED | 20 | 25 | 20 | 100 | 21 | 25 | 22 | 102 |
| | | HIGH | 21 | 25 | 22 | 125 | 22 | 25 | 24 | 127 |
| | 575–3–60 | STD | 14 | 15 | 14 | 79 | 18 | 20 | 19 | 83 |
| | | MED | 15 | 20 | 15 | 83 | 18 | 20 | 19 | 87 |
| | | HIGH | 16 | 20 | 16 | 92 | 19 | 25 | 21 | 96 |
| RGH090 (2–stage cool) | 208/230–3–60 | STD | 40/40 | 50/50 | 42/41 | 195 | 44/44 | 50/50 | 46/46 | 199 |
| | | MED | 41/41 | 50/50 | 43/43 | 199 | 45/45 | 50/50 | 47/47 | 203 |
| | | HIGH | 45/44 | 50/50 | 47/46 | 249 | 49/48 | 60/60 | 52/51 | 253 |
| | 460–3–60 | STD | 19 | 25 | 19 | 97 | 21 | 25 | 22 | 99 |
| | | MED | 20 | 25 | 20 | 100 | 22 | 25 | 23 | 102 |
| | | HIGH | 21 | 25 | 22 | 125 | 23 | 25 | 24 | 127 |
| | 575–3–60 | STD | 15 | 20 | 16 | 79 | 19 | 20 | 20 | 83 |
| | | MED | 16 | 20 | 16 | 83 | 20 | 25 | 21 | 87 |
| | | HIGH | 17 | 20 | 18 | 92 | 21 | 25 | 22 | 96 |
| RGH110 (2–stage cool) | 208/230–3–60 | STD | 51/50 | 60/60 | 53/53 | 254 | 55/54 | 60/60 | 58/57 | 258 |
| | | MED | 54/53 | 60/60 | 58/56 | 304 | 58/57 | 70/70 | 62/61 | 308 |
| | | HIGH | 57/56 | 70/60 | 61/60 | 315 | 61/60 | 70/70 | 65/64 | 319 |
| | 460–3–60 | STD | 24 | 30 | 25 | 122 | 25 | 30 | 27 | 124 |
| | | MED | 25 | 30 | 26 | 147 | 27 | 30 | 28 | 149 |
| | | HIGH | 26 | 30 | 28 | 152 | 28 | 30 | 30 | 154 |
| | 575–3–60 | STD | 19 | 20 | 20 | 97 | 23 | 25 | 24 | 101 |
| | | MED | 20 | 25 | 21 | 106 | 24 | 25 | 25 | 110 |
| | | HIGH | 22 | 25 | 23 | 120 | 26 | 30 | 27 | 124 |
| RGH120 (2–stage cool) | 208/230–3–60 | STD | 50/49 | 60/60 | 52/52 | 279 | 53/53 | 60/60 | 56/56 | 283 |
| | | MED | 53/52 | 60/60 | 56/55 | 329 | 57/56 | 70/60 | 60/59 | 333 |
| | | HIGH | 56/55 | 60/60 | 59/58 | 340 | 60/59 | 70/70 | 64/63 | 344 |
| | 460–3–60 | STD | 25 | 30 | 26 | 134 | 26 | 30 | 28 | 136 |
| | | MED | 26 | 30 | 27 | 159 | 28 | 30 | 29 | 161 |
| | | HIGH | 27 | 30 | 29 | 164 | 29 | 35 | 31 | 166 |
| | 575–3–60 | STD | 19 | 25 | 20 | 107 | 23 | 25 | 24 | 111 |
| | | MED | 20 | 25 | 21 | 116 | 24 | 30 | 26 | 120 |
| | | HIGH | 22 | 25 | 23 | 130 | 26 | 30 | 27 | 134 |

See "Legend and Notes for Tables 6 – 7 on page 22.

LEGEND:

- CO – Convenient outlet
- DISC – Disconnect
- FLA – Full load amps
- IFM – Indoor fan motor
- LRA – Locked rotor amps
- MCA – Minimum circuit amps
- MOCB – Maximum over current protection
- PE – Power exhaust
- UNPWRD CO – Unpowered convenient outlet



Example: Supply voltage is 230-3-60



- AB = 224 v
- BC = 231 v
- AC = 226 v

$$\text{Average Voltage} = \frac{(224 + 231 + 226)}{3} = \frac{681}{3} = 227$$

Determine maximum deviation from average voltage.

- (AB) 227 – 224 = 3 v
- (BC) 231 – 227 = 4 v
- (AC) 227 – 226 = 1 v

Maximum deviation is 4 v.

Determine percent of voltage imbalance.

$$\% \text{ Voltage Imbalance} = 100 \times \frac{4}{227} = 1.76\%$$

This amount of phase imbalance is satisfactory as it is below the maximum allowable 2%.

IMPORTANT: If the supply voltage phase imbalance is more than 2%, contact your local electric utility company immediately.

NOTES:

1. In compliance with NEC requirements for multimotor and combination load equipment (refer to NEC Articles 430 and 440), the overcurrent protective device for the unit shall be fuse or HACR breaker. Canadian units may be fuse or circuit breaker.

2. Unbalanced 3-Phase Supply Voltage

Never operate a motor where a phase imbalance in supply voltage is greater than 2%. Use the following formula to determine the percentage of voltage imbalance.

$$\% \text{ Voltage Imbalance} = 100 \times \frac{\text{max voltage deviation from average voltage}}{\text{average voltage}}$$

FIGURE 36 Wiring for Optional Economizer

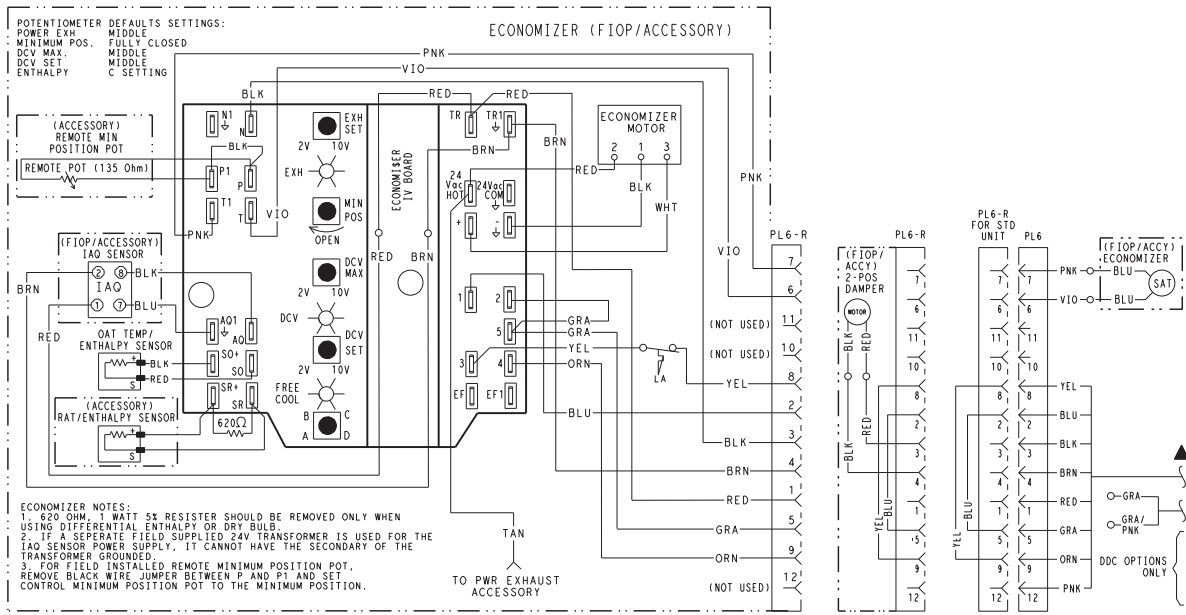

Economizer

2 Position Damper

Unit Without Economizer or 2 Position Damper

Step 13 — Adjust Factory-Installed Options

Smoke Detector —

Smoke detector will be connected at the Controls Connections Board, at terminals marked “Smoke Shutdown”. Remove jumper JMP 3 when ready to energize unit.

Economizer IV Occupancy Switch —

Refer to Fig. 31 for general Economizer IV wiring. External occupancy control is managed through a connection on the Controls Connections Board.

If external occupancy control is desired, connect a time clock or remotely controlled switch (closed for Occupied, open for Unoccupied sequence) at terminals marked OCCUPANCY. Remove or cut jumper JMP 2 to complete the installation.

Step 14 — Install Accessories, As Required

Available accessories include:

- Roof Curb
- Thru-base connection kit (must be installed before unit is set on curb)
- LP conversion kit
- Manual outside air damper
- Two-Position motorized outside air damper
- Economizer IV (with control)
- Barometric relief
- Power exhaust
- Differential dry-bulb sensor (Economizer IV)
- Outdoor enthalpy sensor
- Smoke detector (Supply Air)
- 4-inch filter tracks
- Louvered hail guard
- Hood-type hail guard
- UV-C lamp kit
- Phase monitor control

Refer to separate installation instructions for information on installing these accessories.

III. HOT GAS REHEAT START-UP

STEPS

- 1. CHECK CTB FOR JUMPER 5, 6, 7
JUMPER 5, 6, 7 MUST BE CUT AND OPEN
- 2. OPEN HUMIDISTAT CONTACTS
- 3. START UNIT IN COOLING (CLOSE Y1)

OBSERVE AND RECORD

- A. SUCTION PRESSURE _____ PSIG
 - B. DISCHARGE PRESSURE _____ PSIG
 - C. ENTERING AIR TEMPERATURE _____ °F
 - D. LIQUID LINE TEMPERATURE
AT OUTLET OR REHEAT COIL _____ °F
 - E. CONFIRM CORRECT ROTATION FOR COMPRESSOR
 - F. CHECK FOR CORRECT RAMP-UP OF OUTDOOR FAN MOTOR AS CONDENSER COIL WARMS
- 4. CHECK UNIT CHARGE PER CHARGING CHART
 - 5. SWITCH UNIT TO HIGH-LATENT MODE (SUBCOOLER) BY CLOSING HUMIDISTAT WITH Y1 CLOSED

OBSERVE

- A. REDUCTION IN SUCTION PRESSURE (5 TO 7 PSI EXPECTED)
 - B. DISCHARGE PRESSURE UNCHANGED
 - C. LIQUID TEMPERATURE DROPS TO 50 TO 55°F RANGE
 - D. LSV SOLENOID ENERGIZED (VALVE CLOSES)
- 6. SWITCH UNIT TO DEHUMID (REHEAT) BY OPENING Y1

OBSERVE

- A. SUCTION PRESSURE INCREASES TO NORMAL COOLING LEVEL
 - B. DISCHARGE PRESSURE DECREASES (35 TO 50 PSI)
 - C. LIQUID TEMPERATURE RETURNS TO NORMAL COOLING LEVEL
 - D. LSV SOLENOID ENERGIZED (VALVE CLOSES)
 - E. DSV SOLENOID ENERGIZED, VALVE OPENS
- 7. WITH UNIT IN DEHUMID MODE CLOSE W1
COMPRESSOR AND OUTDOOR FAN STOP; LSV AND DSV SOLENOIDS DE-ENERGIZED
 - 8. OPEN W1 RESTORE UNIT TO DEHUMID MODE
 - 9. OPEN HUMIDISTAT INPUT
COMPRESSOR AND OUTDOOR FAN STOP; LSV AND DSV SOLENOIDS DE-ENERGIZED
 - 10. RESTORE SETPOINTS FOR THERMOSTAT AND HUMIDISTAT

REPEAT PROCESS FOR 2 COMPRESSOR SYSTEMS