

COMMERCIAL HIGH EFFICIENCY PACKAGE GAS HEATING/ELECTRIC COOLING R-22 SINGLE PACKAGE ROOFTOP 3 – 5 TONS (3-Phase – 575 Volt)

BUILT TO LAST, EASY TO INSTALL AND SERVICE

- One-piece, high efficiency electric cooling with a low profile, prewired, tested, and charged at the factory
- Field convertible supply and return openings are intended for installation on a roof top or ground level
- Hermetic-type single scroll compressor
- Compressor anti-cycle protection, loss-of-charge, freeze protection, and high pressure safety switches
- Refrigerant circuits contain a filter drier to trap dirt and moisture
- Non-corrosive condensate pan with choice of bottom or side drain connections. All models have self draining sloping design
- Adjustable belt drive indoor fan standard on all units, with permanently lubricated motors
- Direct-drive propeller outdoor fan totally enclosed with permanently lubricated bearings
- Prepainted, galvanized steel cabinet, primer inner panels, certified at 500-hr salt spray test and noncorrosive screws
- Easily removable panels provide ready access to unit components for rapid removal or maintenance
- Two inch disposable fiberglass type return air filters in dedicated rack with filter access door
- Exclusive integrated gas control board with diagnostics with anti-cycle protection
- Tubular, dimpled gas heat exchangers optimize heat transfer for improved efficiency
- Induced-draft fan for gas combustion
- Outdoor temperature cooling operation from 25°F to 125°F
- Fixed orifice metering devices to precisely control refrigerant flow
- Indoor and outdoor coils constructed of aluminum fins mechanically bonded to seamless copper tubes
- 24-Volt control circuit with circuit breaker
- Thru-the-bottom power entry capability

WARRANTY

- 10 Year heat exchanger limited warranty
- 5 Year compressor limited warranty
- 1 Year parts limited warranty



ISO 9001:2000



As an Energy Star® Partner, International Comfort Products has determined that this product meets the ENERGY STAR® guidelines for energy efficiency.

UNIT PERFORMANCE DATA

UNIT PGH 3-Phase	NOMINAL TONS	COOLING		GAS HEATING CAPACITY/EFFICIENCY		Unit Dimensions H x W x L	Unit Weight
		Net Cap. (Btuh)	SEER	Input Cap. (Btuh)	AFUE		
PGH036SEA00AA	3	36,000	13.0	72,000	82.8	33-5/16" x 73-11/16" x 45"	530
PGH036SFA00AA	3	36,000	13.0	115,000	80.0	33-5/16" x 73-11/16" x 45"	540
PGH048SEA00AA	4	46,000	13.0	115,000	81.0	33-5/16" x 73-11/16" x 45"	560
PGH048SFA00AA	4	46,000	13.0	150,000	80.4	33-5/16" x 73-11/16" x 45"	530
PGH060SEA00AA	5	61,000	13.0	115,000	81.0	33-5/16" x 73-11/16" x 45"	540
PGH060SFA00AA	5	61,000	13.0	150,000	80.4	33-5/16" x 73-11/16" x 45"	560

Table of Contents

	Page
Features/Benefits	1
Model Number Nomenclature	2
Unit Specifications	3-4
Dimensions	6
Performance Data	7-11
Typical Installation	12
Accessories	13 - 17
Controls and Application Data	18
Guide Specifications	18

MODEL NOMENCLATURE

MODEL SERIES	P	G	H	036	S	E	A	00	A	A	A
P = Package											
A = AC											
G = Gas/Electric											
H = High Efficiency											
036 = 36,000											
048 = 48,000											
060 = 60,000											
				NOMINAL COOLING BTU/h							
S = 575-3-60						VOLTAGE					
E = Medium Heat											
F = High Heat						NOMINAL HEATING BTU/h					
A = Standard Motor							MOTOR OPTION				
00 = No Factory Installed Options							FACTORY INSTALLED OPTIONS				
Sales Model Digit											
Engineering Digit											

UNIT SPECIFICATIONS - MODELS

COOLING	PGH036S	PGH048S	PGH060S
ARI Rated Capacity Btuh (Net)	36,000	46,000	61,000
Nominal Tons	3	4	5
SEER	13.0	13.0	13.0
EER	11.2	11.1	11.0
Sound Rating (Bels)	7.6	7.6	8.0
Base Unit Operating Weights (lbs)	530	540	560
ELECTRICAL			
Volts/ 3 Phase/ 60Hertz	575	575	575
Voltage Range Min/Max	518 / 632	518 / 632	518 / 632
Power Supply MCA	7.6	10.3	11.5
Power Supply MOCP*	10	15	15
COMPRESSOR		SCROLL	
Quantity...Model	1...ZR34	1...GC06	1...ZR57
No. of Circuits	1	1	1
RLA / LRA	4.2 / 31	6.4 / 40	7.1 / 50
Oil (Oz.)	42	53	50
REFRIGERATION TYPE		R-22	
Expansion Device	Fixed Metering Device		
Operating Charge (lb. oz.)	5-8	10-2	10-0
CONDENSER FAN		Propeller Type	
Nominal CFM	3500	3500	4100
Quantity..Diameter (in.)	1...22	1...22	1...22
Motor Hp...RPM	1/8...825	1/8...825	1/4...1100
Watts Input (Total)	180	180	320
FLA	0.4	0.4	0.6
CONDENSER COIL		Enhanced Copper tubes, Aluminum Lanced Fins	
Rows...Fin/In.	1...17	2...17	2...17
Total Face Area (sq. ft.)	14.6	16.5	16.5
EVAPORATOR COIL		Enhanced Copper Tubes, Aluminum Double-Wavy Fins	
Rows...Fins/Inches	2...15	2...15	4...15
Total Face Area (sq. ft.)	5.5	5.5	5.5
EVAPORATOR FAN		Centrifugal Type	
Quantity...Size (in.)	1...10 x 10	1...10 x 10	1...10 x 10
Type Drive	Belt	Belt	Belt
Nominal CFM	1200	1600	2000
RPM, Max. Continuous Bhp	1620, 1.2	1620, 1.2	1725, 2.4
FLA	1.9	1.9	2.0
Motor Frame Size	48	48	56
Fan RPM Range	680 - 1044	770 - 1185	1035 - 1460
Motor Bearing	Ball	Ball	Ball
Maximum Allowable RPM	2100	2100	2100
Motor Pulley Pitch / Diameter Min/Max. (in.)	1.9/2.9	1.9/2.9	2.4-3.4
Motor Shaft Diameter (in.)	1/2	1/2	5/8
Fan Pulley Pitch Diam (in)	4.5	4.0	4.0
Belt, Quantity...Type... Length (in.)	1...A...36	1...A...36	1...A...40
Pulley Center Line Distance (in)	10.0-12.4	10.0-12.4	14.7-15.5
Speed Change per Full Turn of Movable Pulley Flange (RPM)	65	70	75
Pulley Max. full Turns From Closed Position	5	5	6
Factory Setting	3	3	3
Factory Speed Setting RPM	826	936	1248
Fan Shaft Diam. at Pulley	5/8	5/8	5/8
SEE LEGENDS AND NOTES ON FOLLOWING PAGE			

LEGEND

- Bhp = Brake Horsepower
- TXV = Thermostatic Expansion Valve
- * Fuse or HACR Circuit breaker
- Bels - Sound Levels
- EER - Energy Efficiency Ratio
- IPLV - Integrated Part Load Values
- MCA - Minimum Circuit Amps
- MOCP - Maximum Over-current Protection
- FLA - Full Load Amps
- LRA - Locked Rotor Amps
- RLA - Rated Load Amps

+Rollout switch is manual reset.

NOTE: The PGH units have a low-pressure switch (standard) located on the suction side.

NOTE: Minimum allowable temperature of mixed-air entering the heat exchanger during first-stage heating is 45F. There is no minimum mixed-air temperature limitation during second-stage heating. For entering-air temperatures below 45 F both stages of heat must be energized together to minimize condensation issues and ensure proper unit operation.

NOTES:

1. In compliance with NEC requirements for multimotor and combination load equipment (refer to NEC Articles 430 and 440), the over-current protective device for the unit shall be fuse or HACR breaker. Canadian units may be fuse or circuit breaker.

2. Unbalanced 3-Phase Supply Voltage

Never operate a motor where a phase imbalance in supply voltage is greater than 2%. Use the following formula to determine the percent voltage imbalance.

% Voltage Imbalance

$$= 100 \times \frac{\text{max voltage deviation from average voltage}}{\text{average voltage}}$$

LEGENDS AND NOTES

- NOTES: 1. Rated in accordance with ARI Standards 210/240, latest revision
2. ARI ratings are net values, reflecting the effects of circulating fan heat.
3. Ratings are based on:
Cooling Standard: 80F db, 67F wb indoor entering air temperature and 95F db air entering outdoor unit.
IPLV Standard: 80F db, 67F wb indoor entering air temperature and 80F db entering air temperature.

EXAMPLE: Supply voltage is 460-3-60.

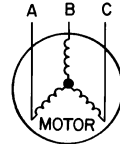

$$\begin{aligned} AB &= 452 \text{ v} & \text{Average Voltage} &= \frac{452 + 464 + 455}{3} \\ BC &= 464 \text{ v} & &= \frac{1371}{3} \\ AC &= 455 \text{ v} & &= 457 \end{aligned}$$

Determine maximum deviation from average voltage.

- (AB) 457 - 452 = 5 V
- (BC) 464 - 457 = 7 V
- (AC) 457 - 455 = 2 V

Maximum deviation is 7 v.

Determine percent voltage imbalance.

$$\% \text{ Voltage Imbalance} = 100 \times \frac{7}{457} = 1.53\%$$

This amount of phase imbalance is satisfactory as it is below the maximum allowable 2%.

IMPORTANT: If the supply voltage phase imbalance is more than 2%, contact your local electric utility company immediately.

PGH036-060 BASE UNIT DIMENSIONS

CONNECTION SIZES

A	1-3/8" DIA. [135] FIELD POWER SUPPLY HOLE
B	2" DIA. [51] POWER SUPPLY KNOCK-OUT
C	1-3/4" DIA. [54] CHARGING PORT HOLE
D	7/8" DIA. [22] FIELD CONTROL WIRING HOLE
E	3/4"-14 NPT CONDENSATE DRAIN
F	1/2"-14 NPT GAS CONNECTION
G	2-1/2" DIA. [64] POWER SUPPLY KNOCK-OUT

BOTTOM POWER CHART. USE THESE HOLES REQ'D FOR USE WITH ACCESSORY PACKAGES

DNB1TWPWR001A01	DNB1TWPWR003A01
THREADED CONDUIT SIZE	REQ'D HOLE SIZES (MAX.)
1/2"	7/8" [22.2]
3/4"	1 1/8" [28.4]
1" (003)	1 1/4" [31.8]
1 1/2" (001, 003)	1 7/8" [47.6]
2" (003)	2 1/4" [60.3]

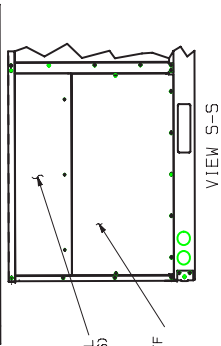

Unit PGH	STD. WEIGHT LB	UNIT WEIGHT KG	CORNER WEIGHT LB	CORNER WEIGHT KG	(A) CORNER LB	(B) CORNER LB	(C) CORNER LB	(D) CORNER LB	"J" FT	"J" MM		
036	530	240	127	57.6	122	55.3	138	62.6	143	64.9	2'-9 5/16"	846.5
048	540	245	129	58.5	124	56.2	141	64.0	146	66.2	2'-9 1/2"	854.0
060	560	254	134	60.8	129	58.5	146	66.2	151	68.5	2'-9 1/2"	854.0

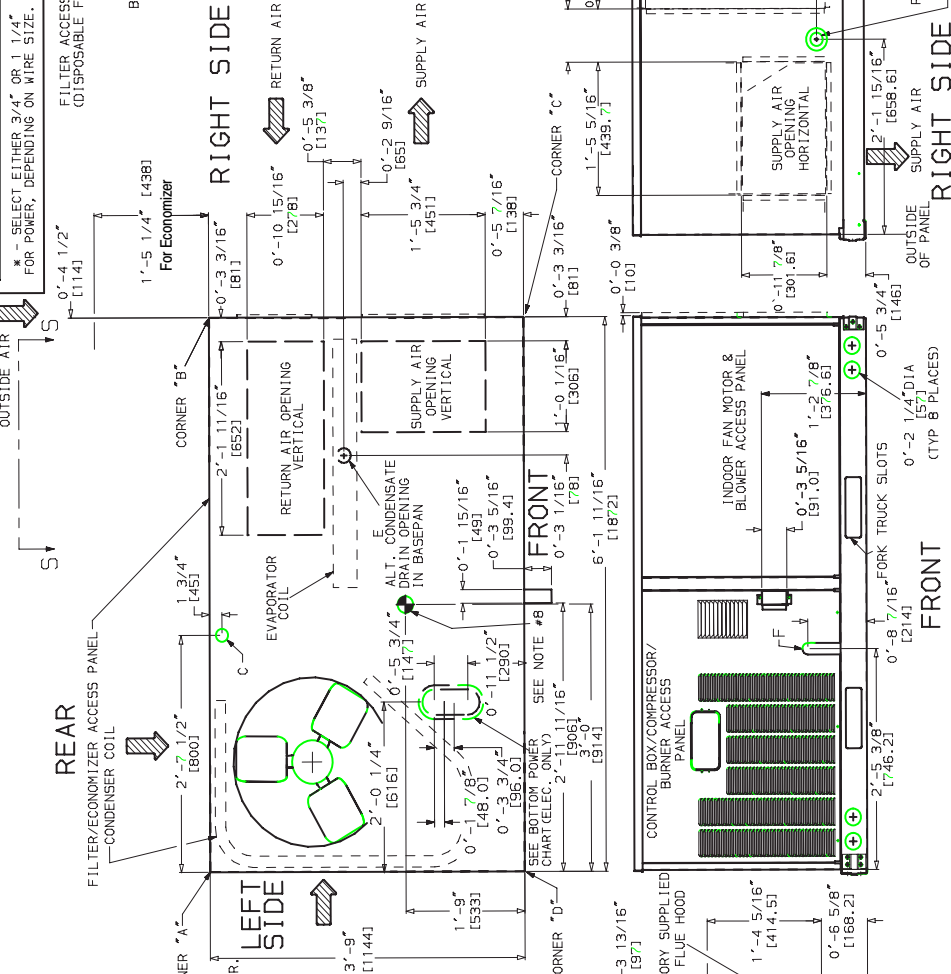

- NOTES:
- DIMENSIONS IN [] ARE IN MILLIMETERS.
 - CENTER OF GRAVITY.
 - DIRECTION OF AIR FLOW.
 - ON VERTICAL DISCHARGE UNITS, DUCTWORK TO BE ATTACHED TO ACCESSORY ROOF CURB ONLY. FOR HORIZONTAL DISCHARGE UNITS, FIELD-SHARED OPENINGS SHOULD BE ATTACHED TO UNITS, FIELD-SHARED OPENINGS, AND ALL DUCTWORK SHOULD BE ATTACHED TO THE FLANGES.
 - MINIMUM CLEARANCE (LOCAL CODES OR JURISDICTION MAY PREVAIL):
 - UNIT, FLUE SIDE AND COMBUSTIBLE SURFACES: 18 IN. WHEN USING ACCESSORY FUEL DISCHARGE DEFLECTOR; 19 IN. WHEN NOT USING ACCESSORY FUEL DISCHARGE DEFLECTOR.
 - BOTTOM OF UNIT TO COMBUSTIBLE SURFACES (WHEN NOT USING CURB) 1 INCH.
 - BOTTOM OF BASE RAIL TO COMBUSTIBLE SURFACES (WHEN NOT USING CURB) 0 INCHES.
 - PROPER AIR FLOW: 36 INCHES UNDER 32 INCHES THE OTHER SIDE GETTING THE GREATER CLEARANCE IS OPTIONAL.
 - OVERHEAD: 60 INCHES TO ASSURE PROPER CONDENSER FAN OPERATION.
 - BETWEEN UNITS, CONTROL BOX SIDE: 42 IN. PER NEC.
 - BETWEEN UNITS, FLUE HOOD SIDE: 36 IN. PER NEC.
 - BETWEEN UNIT AND BLOCK OR CONCRETE WALLS AND OTHER GROUNDED SURFACES, CONTROL BOX SIDE, 42 IN. PER NEC.
 - HORIZONTAL SUPPLY AND RETURN END, 0 INCHES WHEN THE ALTERNATE CONDENSATE DRAIN IS USED.
 - WITH THE EXCEPTION OF THE CLEARANCE FOR THE CONDENSER COIL AND COMBUSTION SIDE AS STATED IN NOTE #5, b, c, d, e, f, g, h, i, j, k, l, m, n, o, p, q, r, s, t, u, v, w, x, y, z, CLEARANCE REQUIREMENTS ARE AS SHOWN.
 - UNITS MAY BE INSTALLED ON COMBUSTIBLE FLOORS MADE FROM WOOD OR CLASS A, B, OR C ROOF COVERING MATERIAL IF SET ON BASE RAIL.
 - THE VERTICAL CENTER OF GRAVITY IS 1'-6" [457] UP FROM THE BOTTOM OF THE BASE RAIL.

COOLING CAPACITIES, STANDARD UNITS

PGH036 (3 TONS)												
Temp (F) Air Ent Condenser (Edb)		Air Entering Evaporator — Cfm/BF										
		900/0.14			1200/0.17			1500/0.20				
		Air Entering Evaporator — Ewb										
		72	67	62	72	67	62	72	67	62		
75	TC	41.9	38.7	35.7	43.5	40.8	37.7	44.8	41.8	39.0		
	SHC	20.4	25.2	29.7	21.8	28.2	33.8	23.3	30.7	37.0		
	kW	2.19	2.16	2.12	2.21	2.18	2.15	2.23	2.19	2.16		
85	TC	40.7	37.5	34.5	42.1	39.3	36.4	43.5	40.4	37.6		
	SHC	19.9	24.7	29.2	21.5	27.7	33.2	23.2	30.3	36.4		
	kW	2.46	2.42	2.39	2.47	2.44	2.41	2.50	2.45	2.42		
95	TC	39.3	36.1	33.1	40.8	37.8	34.9	42.0	38.9	36.1		
	SHC	19.5	24.1	28.4	21.1	27.2	32.5	22.8	29.9	35.6		
	kW	2.75	2.71	2.66	2.77	2.73	2.69	2.79	2.74	2.71		
105	TC	37.7	34.6	31.7	39.3	36.2	33.4	40.1	37.2	34.7		
	SHC	18.8	23.5	27.8	20.7	26.6	31.8	22.1	29.3	34.7		
	kW	3.06	3.02	2.98	3.09	3.04	3.01	3.10	3.06	3.03		
115	TC	36.0	33.0	29.7	37.4	34.5	31.5	38.1	35.5	33.2		
	SHC	18.3	22.9	26.7	19.9	26.1	30.9	21.3	28.7	33.2		
	kW	3.41	3.36	3.31	3.43	3.39	3.34	3.44	3.41	3.37		
125	TC	34.2	31.3	27.8	35.6	32.7	29.4	36.3	33.6	31.9		
	SHC	17.6	22.2	25.8	19.4	25.4	29.4	20.8	28.0	31.8		
	kW	3.78	3.73	3.66	3.80	3.76	3.71	3.81	3.78	3.75		

PGH048 (4 TONS)													
Temp (F) Air Ent Condenser (Edb)		Air Entering Evaporator — Cfm/BF											
		1200/0.17			1450/0.19			1600/0.21			2000/0.24		
		Air Entering Evaporator — Ewb (F)											
		72	67	62	72	67	62	72	67	62	72	67	62
75	TC	54.0	50.7	44.2	55.9	52.2	47.7	56.4	52.8	49.1	58.1	54.5	50.6
	SHC	26.1	32.7	37.5	27.6	35.1	41.8	28.2	36.2	43.8	30.2	39.5	47.5
	kW	2.81	2.80	2.76	2.83	2.81	2.78	2.83	2.80	2.79	2.84	2.82	2.79
85	TC	52.2	48.9	41.9	54.1	50.4	45.9	54.5	51.0	47.2	55.3	52.3	48.7
	SHC	25.4	32.0	36.4	26.9	34.5	40.8	27.5	35.7	42.8	28.6	38.5	46.6
	kW	3.20	3.19	3.15	3.22	3.20	3.17	3.22	3.20	3.18	3.22	3.20	3.18
95	TC	50.7	46.9	39.5	51.9	48.4	43.5	52.5	48.9	45.2	53.9	50.1	46.7
	SHC	24.9	31.1	35.0	26.1	33.6	39.6	26.8	34.7	41.8	28.8	37.5	45.6
	kW	3.64	3.61	3.57	3.65	3.62	3.60	3.65	3.62	3.60	3.67	3.63	3.61
105	TC	48.8	44.5	36.7	49.8	46.2	40.7	50.2	46.7	42.1	51.5	48.2	44.7
	SHC	24.3	30.2	33.6	25.3	32.8	38.2	26.0	33.9	40.3	27.9	37.4	44.4
	kW	4.12	4.09	4.03	4.12	4.09	4.06	4.12	4.09	4.07	4.14	4.11	4.08
115	TC	46.5	41.1	34.3	47.7	43.3	37.0	48.0	44.4	38.5	48.9	45.7	42.0
	SHC	23.4	28.9	32.4	24.9	31.8	36.3	25.4	33.4	38.3	27.1	36.9	42.0
	kW	4.64	4.59	4.53	4.65	4.62	4.55	4.64	4.63	4.56	4.65	4.63	4.60
125	TC	43.8	37.5	32.4	45.1	39.0	33.8	45.3	40.1	35.4	46.3	42.6	38.8
	SHC	22.5	27.4	31.5	24.1	30.2	33.7	24.7	31.9	35.4	26.5	35.9	38.8
	kW	5.19	5.13	5.05	5.20	5.15	5.09	5.19	5.17	5.11	5.20	5.19	5.15

PGH060 (5 TONS)													
Temp (F) Air Ent Condenser (Edb)		Air Entering Evaporator — Cfm/BF											
		1500/0.08			1750/0.09			2000/0.11			2500/0.13		
		Air Entering Evaporator — Ewb (F)											
		72	67	62	72	67	62	72	67	62	72	67	62
75	TC	70.8	65.4	58.5	72.5	67.3	61.1	73.0	68.4	62.8	74.8	70.3	64.8
	SHC	34.1	42.7	49.9	35.7	45.5	54.2	36.8	48.0	57.8	39.6	53.0	63.4
	kW	3.53	3.49	3.44	3.55	3.50	3.46	3.55	3.51	3.47	3.57	3.54	3.48
85	TC	68.9	63.2	55.3	70.5	65.1	57.9	72.2	66.4	60.2	73.2	68.1	62.9
	SHC	33.5	41.8	48.4	35.0	44.8	52.8	37.0	47.6	56.8	39.3	52.5	62.4
	kW	3.98	3.94	3.87	4.00	3.96	3.90	4.03	3.97	3.92	4.04	3.99	3.94
95	TC	66.8	60.6	52.4	68.3	62.5	54.3	69.3	63.8	56.6	71.2	65.6	60.6
	SHC	32.8	40.7	47.0	34.5	43.8	51.1	36.0	46.7	55.0	39.1	51.8	60.5
	kW	4.48	4.43	4.35	4.50	4.45	4.37	4.51	4.46	4.40	4.55	4.48	4.44
105	TC	64.3	57.7	49.9	65.9	59.8	51.7	66.9	61.1	54.1	68.4	62.8	58.4
	SHC	32.0	39.6	45.8	33.7	42.8	49.7	35.3	45.7	53.5	38.4	51.0	58.4
	kW	5.03	4.96	4.87	5.05	4.99	4.90	5.06	5.00	4.93	5.08	5.02	4.98
115	TC	61.5	54.8	47.3	62.8	56.7	49.1	64.0	58.2	51.6	65.4	59.9	56.1
	SHC	31.0	38.4	44.5	32.5	41.6	48.2	34.4	44.6	51.6	37.4	50.0	56.1
	kW	5.61	5.55	5.46	5.62	5.58	5.49	5.65	5.60	5.52	5.67	5.61	5.57
125	TC	58.7	51.6	44.5	59.9	53.4	46.2	60.8	54.9	49.0	62.2	56.8	53.5
	SHC	30.0	37.2	43.1	31.7	40.4	46.2	33.3	43.4	48.9	36.4	48.9	53.4
	kW	6.27	6.19	6.09	6.28	6.21	6.13	6.29	6.24	6.17	6.31	6.27	6.22

— Standard Ratings

LEGEND

- BF — Bypass Factor
- Edb — Entering Dry Bulb
- Ewb — Entering Wet Bulb
- kW — Compressor Motor Power Input
- SHC — Sensible Heat Capacity (1000 Btuh) Gross
- TC — Total Capacity (1000 Btuh) Gross

NOTES:

1. Direct interpolation is permissible. Do not extrapolate.
2. The following formulas may be used:

Fan Rpm at Motor Pulley Setting With Standard Motor*

UNIT PGH	MOTOR PULLEY TURNS OPEN												
	0	1/2	1	1 1/2	2	2 1/2	3	3 1/2	4	4 1/2	5	5 1/2	6
036	1044	1008	971	935	898	862	826	789	753	716	680	—	—
048	1185	1144	1102	1061	1019	978	936	895	853	812	770	—	—
060	1460	1425	1389	1354	1318	1283	1248	1212	1177	1141	1106	1070	1035

*Approximate fan rpm shown (standard motor/drive).

Evaporator-Fan Motor Data — Standard Motor

UNIT PGH	UNIT PHASE	MAXIMUM CONTINUOUS BHP*	MAXIMUM OPERATING WATTS*	UNIT VOLTAGE	MAXIMUM AMP DRAW
036	Three	1.20	1000	575	2.2
048	Three	1.20	1000	575	2.2
060	Three	2.40	2120	575	3.0

LEGEND

Bhp — Brake Horsepower

*Extensive motor and electrical testing on these units ensures that the full horsepower and watts range of the motors can be utilized with confidence. Using the fan motors up to the ratings shown in this table will not result in nuisance tripping or premature motor failure. Unit warranty will not be affected.

Outdoor Sound Power (Total Unit)

UNIT PGH	ARI RATING (decibels)	OCTAVE BANDS							
		63	125	250	500	1000	2000	4000	8000
036 – 048	76	55.9	66.0	64.0	66.2	68.4	64.5	61.7	57.3
060	80	59.1	68.9	68.7	71.9	74.0	68.9	65.7	59.0

LEGEND

ARI – Air Conditioning and Refrigeration Institute

GENERAL FAN PERFORMANCE NOTES

1. Values include losses for filters, unit casing, and wet coils.
2. Extensive motor and electrical testing on these units ensures that the full range of the motor can be utilized with confidence. Using the fan motors up to the ratings shown will not result in nuisance tripping or premature motor failure. Unit warranty will not be affected.
3. Use of a field-supplied motor may affect wire sizing.
4. Interpolation is permissible. Do not extrapolate.
5. Performance includes clean filter and wet coil.

ALTITUDE COMPENSATION* — PGH036–060

ELEVATION (ft)	72,000 AND 115,000/ 60,000 and 90,000 BTUH NOMINAL INPUT		150,000/120,000 BTUH NOMINAL INPUT	
	Natural Gas Orifice Size†	Liquid Propane Orifice Size†	Natural Gas Orifice Size	Liquid Propane Orifice Size†
0–2,000	33/38	43	30/32	38
2,000	34/39	43	30/33	39
3,000	35/40	44	31/34	40
4,000	36/41	44	32/35	41
5,000	36/41	44	33/35	42
6,000	37/42	45	34/36	43
7,000	37/42	45	35/37	43
8,000	38/43	46	36/37	44
9,000	39/43	47	37/38	44
10,000	41/44	48	38/40	45
11,000	43/45	48	39/41	45
12,000	44/45	49	40/42	46
13,000	44/46	49	41/43	47
14,000	45/47	50	42/43	47

ALTITUDE DERATING FACTOR*

ELEVATION	MAXIMUM HEATING VALUE (Btu/ft ³)
0–2000	1100
2001–3000	1050
3001–4000	1000
4001–5000	950
5001–6000	900

*Derating of the unit is not required unless the heating value of the gas exceeds the values listed in the table above, or if the elevation exceeds 6000 ft. Derating conditions must be 4% per thousand ft above 2000 ft. For example, at 4000 ft, if the heating value of the gas exceeds 1000 Btu/ft³, the unit will require a 16% derating. For elevations above 6000 ft, the same formula applies. For example, at 7000 ft, the unit will require a 28% derating of the maximum heating value per the National Fuel Gas Code.

*As the height above sea level increases, there is less oxygen per cubic foot of air. Therefore, the input rate should be reduced at higher altitudes.

†Orifices are available through your local distributor.

Fan Performance PGH036 — Vertical Discharge Units; Standard Motor (Belt Drive)*

AIRFLOW CFM	EXTERNAL STATIC PRESSURE (in. wg)														
	0.2			0.4			0.6			0.8			1.0		
	Rpm	Bhp	Watts	Rpm	Bhp	Watts	Rpm	Bhp	Watts	Rpm	Bhp	Watts	Rpm	Bhp	Watts
900	567	0.15	145	688	0.22	222	786	0.30	296	871	0.37	368	947	0.44	437
1000	599	0.18	177	717	0.27	265	814	0.35	349	897	0.43	430	972	0.51	509
1100	632	0.22	215	747	0.31	313	842	0.41	407	925	0.50	498	999	0.59	587
1200	666	0.26	257	778	0.37	367	871	0.47	471	952	0.57	572	1025	0.67	670
1300	701	0.31	306	810	0.43	426	901	0.54	540	981	0.65	651	1053	0.76	760
1400	737	0.36	361	842	0.49	491	931	0.62	616	1010	0.74	738	1081	0.86	856
1500	773	0.42	422	875	0.57	564	963	0.70	699	1040	0.84	831	1110	0.96	960

Fan Performance PGH036 — Vertical Discharge Units; Standard Motor (Belt Drive)* (Cont.)

AIRFLOW CFM	EXTERNAL STATIC PRESSURE (in. wg)														
	1.2			1.4			1.6			1.8			2.0		
	Rpm	Bhp	Watts	Rpm	Bhp	Watts	Rpm	Bhp	Watts	Rpm	Bhp	Watts	Rpm	Bhp	Watts
900	1016	0.51	505	1080	0.57	572	1139	0.64	637	1195	0.71	702	1249	0.77	765
1000	1041	0.59	587	1104	0.67	662	1163	0.74	737	1219	0.81	811	1272	0.89	883
1100	1066	0.68	674	1129	0.76	759	1188	0.85	843	1243	0.93	925	1296	1.01	1007
1200	1093	0.77	767	1155	0.87	861	1213	0.96	955	1268	1.05	1047	1321	1.14	1137
1300	1119	0.87	866	1181	0.98	970	1239	1.08	1073	1294	1.18	1175	—	—	—
1400	1147	0.98	972	1208	1.09	1086	—	—	—	—	—	—	—	—	—
1500	1175	1.09	1086	—	—	—	—	—	—	—	—	—	—	—	—

NOTES:

1. Gray cells indicate field-supplied drive is required.
2. Maximum continuous bhp is 1.20.
3. See general fan performance notes.

LEGEND

Bhp — Brake Horsepower
Watts — Input Watts to Motor
 *Motor drive range: 680 to 1044 rpm. All other rpms require field-supplied drive.

Fan Performance PGH048 — Vertical Discharge Units; Standard Motor (Belt Drive)*

AIRFLOW CFM	EXTERNAL STATIC PRESSURE (in. wg)														
	0.2			0.4			0.6			0.8			1.0		
	Rpm	Bhp	Watts	Rpm	Bhp	Watts	Rpm	Bhp	Watts	Rpm	Bhp	Watts	Rpm	Bhp	Watts
1200	666	0.26	257	778	0.37	367	871	0.47	471	952	0.57	572	1025	0.67	670
1300	701	0.31	306	810	0.43	426	901	0.54	540	981	0.65	651	1053	0.76	760
1400	737	0.36	361	842	0.49	491	931	0.62	616	1010	0.74	738	1081	0.86	856
1500	773	0.42	422	875	0.57	564	963	0.70	699	1040	0.84	831	1110	0.96	960
1600	810	0.49	491	909	0.65	643	994	0.79	790	1070	0.94	932	1140	1.08	1070
1700	847	0.57	567	943	0.73	730	1027	0.89	888	1101	1.05	1040	1170	1.20	1189
1800	885	0.66	652	978	0.83	826	1060	1.00	994	1133	1.16	1157	—	—	—
1900	923	0.75	745	1014	0.94	930	1093	1.11	1109	—	—	—	—	—	—
2000	962	0.85	847	1049	1.05	1043	—	—	—	—	—	—	—	—	—

Fan Performance PGH048 — Vertical Discharge Units; Standard Motor (Belt Drive)* (Cont.)

AIRFLOW CFM	EXTERNAL STATIC PRESSURE (in. wg)														
	1.2			1.4			1.6			1.8			2.0		
	Rpm	Bhp	Watts	Rpm	Bhp	Watts	Rpm	Bhp	Watts	Rpm	Bhp	Watts	Rpm	Bhp	Watts
1200	1093	0.77	767	1155	0.87	861	1213	0.96	955	1268	1.05	1047	1321	1.14	1137
1300	1119	0.87	866	1181	0.98	970	1239	1.08	1073	1294	1.18	1175	—	—	—
1400	1147	0.98	972	1208	1.09	1086	—	—	—	—	—	—	—	—	—
1500	1175	1.09	1086	—	—	—	—	—	—	—	—	—	—	—	—
1600	—	—	—	—	—	—	—	—	—	—	—	—	—	—	—
1700	—	—	—	—	—	—	—	—	—	—	—	—	—	—	—
1800	—	—	—	—	—	—	—	—	—	—	—	—	—	—	—
1900	—	—	—	—	—	—	—	—	—	—	—	—	—	—	—
2000	—	—	—	—	—	—	—	—	—	—	—	—	—	—	—

NOTES:

1. Gray cells indicate field-supplied drive is required.
2. Maximum continuous bhp is 2.40.
3. See general fan performance notes.

LEGEND

Bhp — Brake Horsepower
Watts — Input Watts to Motor
 *Motor drive range: 770 to 1185 rpm. All other rpms require field-supplied drive.

Fan Performance PGH060 — Vertical Discharge Units; Standard Motor (Belt Drive)*

AIRFLOW CFM	EXTERNAL STATIC PRESSURE (in. wg)														
	0.2			0.4			0.6			0.8			1.0		
	Rpm	Bhp	Watts	Rpm	Bhp	Watts	Rpm	Bhp	Watts	Rpm	Bhp	Watts	Rpm	Bhp	Watts
1500	848	0.42	371	968	0.55	486	1069	0.68	600	1158	0.80	715	1238	0.94	831
1600	887	0.49	433	1004	0.63	556	1103	0.76	678	1190	0.90	800	1269	1.04	922
1700	927	0.57	502	1040	0.71	633	1137	0.86	763	1223	1.00	892	1302	1.15	1022
1800	967	0.65	579	1077	0.81	718	1172	0.96	856	1257	1.12	993	1334	1.27	1130
1900	1007	0.75	663	1115	0.91	811	1208	1.08	957	1291	1.24	1101	1368	1.40	1246
2000	1048	0.85	757	1153	1.03	913	1244	1.20	1066	1326	1.37	1219	1401	1.54	1371
2100	1090	0.97	859	1191	1.15	1023	1281	1.33	1185	1361	1.51	1345	1435	1.69	1505
2200	1131	1.09	970	1230	1.29	1143	1318	1.48	1313	1397	1.67	1481	1470	1.86	1649
2300	1173	1.23	1091	1269	1.43	1273	1355	1.63	1451	1433	1.83	1627	1505	2.03	1803
2400	1215	1.38	1223	1309	1.59	1413	1393	1.80	1600	1470	2.01	1784	1540	2.21	1967
2500	1258	1.54	1365	1349	1.76	1564	1431	1.98	1759	1506	2.20	1951	—	—	—

Fan Performance PGH060 — Vertical Discharge Units; Standard Motor (Belt Drive)* (Cont.)

AIRFLOW CFM	EXTERNAL STATIC PRESSURE (in. wg)														
	1.2			1.4			1.6			1.8			2.0		
	Rpm	Bhp	Watts	Rpm	Bhp	Watts	Rpm	Bhp	Watts	Rpm	Bhp	Watts	Rpm	Bhp	Watts
1500	1312	1.07	948	1380	1.20	1067	1445	1.34	1189	1506	1.48	1312	1564	1.62	1437
1600	1342	1.18	1047	1411	1.32	1173	1474	1.46	1300	1535	1.61	1429	1593	1.76	1560
1700	1374	1.30	1153	1441	1.45	1286	1505	1.60	1420	1565	1.75	1555	1622	1.91	1692
1800	1406	1.43	1268	1473	1.58	1407	1535	1.74	1548	1595	1.90	1690	1652	2.06	1833
1900	1438	1.57	1391	1504	1.73	1537	1567	1.90	1685	1626	2.06	1833	1682	2.23	1983
2000	1471	1.72	1523	1536	1.89	1677	1598	2.06	1831	1657	2.24	1986	—	—	—
2100	1504	1.87	1665	1569	2.06	1825	1630	2.24	1986	—	—	—	—	—	—
2200	1538	2.04	1816	1602	2.23	1984	—	—	—	—	—	—	—	—	—
2300	1572	2.23	1978	—	—	—	—	—	—	—	—	—	—	—	—
2400	—	—	—	—	—	—	—	—	—	—	—	—	—	—	—
2500	—	—	—	—	—	—	—	—	—	—	—	—	—	—	—

NOTES:

1. Gray cells indicate field-supplied drive is required.
2. Maximum continuous bhp is 2.40.
3. See general fan performance notes.

LEGEND

Bhp — Brake Horsepower
Watts — Input Watts to Motor
 *Motor drive range: 1035 to 1460 rpm. All other rpms require field-supplied drive.

Fan Performance PGH036 — Horizontal Discharge Units; Standard Motor (Belt Drive)*

AIRFLOW CFM	EXTERNAL STATIC PRESSURE (in. wg)														
	0.2			0.4			0.6			0.8			1.0		
	Rpm	Bhp	Watts	Rpm	Bhp	Watts	Rpm	Bhp	Watts	Rpm	Bhp	Watts	Rpm	Bhp	Watts
900	553	0.14	134	681	0.22	221	782	0.32	316	870	0.42	417	948	0.53	526
1000	582	0.16	163	707	0.26	257	807	0.36	358	894	0.47	466	971	0.58	580
1100	612	0.20	196	734	0.30	297	833	0.41	405	919	0.52	519	995	0.64	639
1200	643	0.23	234	762	0.34	343	859	0.46	458	944	0.58	579	1020	0.71	705
1300	675	0.28	277	790	0.40	394	886	0.52	517	969	0.65	644	1044	0.78	777
1400	707	0.33	326	819	0.45	452	913	0.58	581	996	0.72	716	1070	0.86	855
1500	740	0.38	382	849	0.52	515	941	0.66	653	1023	0.80	795	1096	0.95	941

Fan Performance PGH036 — Horizontal Discharge Units; Standard Motor (Belt Drive)* (Cont.)

AIRFLOW CFM	EXTERNAL STATIC PRESSURE (in. wg)														
	1.2			1.4			1.6			1.8			2.0		
	Rpm	Bhp	Watts	Rpm	Bhp	Watts	Rpm	Bhp	Watts	Rpm	Bhp	Watts	Rpm	Bhp	Watts
900	1019	0.64	640	1084	0.76	760	1146	0.89	885	1203	1.02	1016	1258	1.16	1152
1000	1042	0.70	700	1107	0.83	825	1168	0.96	956	1225	1.10	1091	—	—	—
1100	1065	0.77	765	1130	0.90	896	1190	1.04	1032	1247	1.18	1173	—	—	—
1200	1089	0.84	837	1153	0.98	974	1213	1.12	1115	—	—	—	—	—	—
1300	1113	0.92	915	1177	1.06	1058	—	—	—	—	—	—	—	—	—
1400	1138	1.01	1000	1201	1.15	1149	—	—	—	—	—	—	—	—	—
1500	1163	1.10	1092	—	—	—	—	—	—	—	—	—	—	—	—

NOTES:

1. Gray cells indicate field-supplied drive is required.
2. Maximum continuous bhp is 1.20.
3. See general fan performance notes.

LEGEND

Bhp — Brake Horsepower
Watts — Input Watts to Motor
 *Motor drive range: 680 to 1044 rpm. All other rpms require field-supplied drive.

Fan Performance PGH048 — Horizontal Discharge Units; Standard Motor (Belt Drive)*

AIRFLOW CFM	EXTERNAL STATIC PRESSURE (in. wg)														
	0.2			0.4			0.6			0.8			1.0		
	Rpm	Bhp	Watts	Rpm	Bhp	Watts	Rpm	Bhp	Watts	Rpm	Bhp	Watts	Rpm	Bhp	Watts
1200	643	0.23	234	762	0.34	343	859	0.46	458	944	0.58	579	1020	0.71	705
1300	675	0.28	277	790	0.40	394	886	0.52	517	969	0.65	644	1044	0.78	777
1400	707	0.33	326	819	0.45	452	913	0.58	581	996	0.72	716	1070	0.86	855
1500	740	0.38	382	849	0.52	515	941	0.66	653	1023	0.80	795	1096	0.95	941
1600	773	0.45	444	879	0.59	586	970	0.73	731	1050	0.88	880	1123	1.04	1034
1700	807	0.52	513	910	0.67	663	999	0.82	817	1078	0.98	973	1150	1.14	1134
1800	841	0.59	589	942	0.75	749	1029	0.91	910	1106	1.08	1074	—	—	—
1900	875	0.68	674	974	0.85	842	1059	1.02	1012	1135	1.19	1184	—	—	—
2000	910	0.77	767	1006	0.95	944	1090	1.13	1122	—	—	—	—	—	—

Fan Performance PGH048 — Horizontal Discharge Units; Standard Motor (Belt Drive)* (Cont.)

AIRFLOW CFM	EXTERNAL STATIC PRESSURE (in. wg)														
	1.2			1.4			1.6			1.8			2.0		
	Rpm	Bhp	Watts	Rpm	Bhp	Watts	Rpm	Bhp	Watts	Rpm	Bhp	Watts	Rpm	Bhp	Watts
1200	1089	0.84	837	1153	0.98	974	1213	1.12	1115	—	—	—	—	—	—
1300	1113	0.92	915	1177	1.06	1058	—	—	—	—	—	—	—	—	—
1400	1138	1.01	1000	1201	1.15	1149	—	—	—	—	—	—	—	—	—
1500	1163	1.10	1092	—	—	—	—	—	—	—	—	—	—	—	—
1600	1189	1.20	1191	—	—	—	—	—	—	—	—	—	—	—	—
1700	—	—	—	—	—	—	—	—	—	—	—	—	—	—	—
1800	—	—	—	—	—	—	—	—	—	—	—	—	—	—	—
1900	—	—	—	—	—	—	—	—	—	—	—	—	—	—	—
2000	—	—	—	—	—	—	—	—	—	—	—	—	—	—	—

NOTES:

1. Gray cells indicate field-supplied drive is required.
2. Maximum continuous bhp is 1.20.
3. See general fan performance notes.

LEGEND

Bhp — Brake Horsepower
Watts — Input Watts to Motor
 *Motor drive range: 770 to 1185 rpm. All other rpms require field-supplied drive.

Fan Performance PGH060 — Horizontal Discharge Units; Standard Motor (Belt Drive)*

AIRFLOW CFM	EXTERNAL STATIC PRESSURE (in. wg)														
	0.2			0.4			0.6			0.8			1.0		
	Rpm	Bhp	Watts	Rpm	Bhp	Watts	Rpm	Bhp	Watts	Rpm	Bhp	Watts	Rpm	Bhp	Watts
1500	800	0.39	350	904	0.49	438	999	0.60	535	1087	0.72	640	1169	0.85	753
1600	839	0.46	412	938	0.57	505	1030	0.68	605	1115	0.80	714	1195	0.93	829
1700	879	0.54	483	974	0.65	580	1062	0.77	684	1144	0.90	796	1221	1.03	914
1800	919	0.63	561	1010	0.75	663	1095	0.87	771	1174	1.00	886	1250	1.14	1008
1900	960	0.73	648	1047	0.85	754	1129	0.98	867	1206	1.11	986	1279	1.25	1111
2000	1001	0.84	744	1085	0.96	855	1163	1.09	972	1238	1.23	1095	1309	1.38	1224
2100	1043	0.96	850	1123	1.09	965	1199	1.22	1086	1271	1.37	1213	1340	1.52	1346
2200	1085	1.09	966	1162	1.22	1086	1235	1.36	1211	1305	1.51	1342	1372	1.67	1479
2300	1127	1.23	1092	1201	1.37	1217	1272	1.52	1347	1340	1.67	1482	1405	1.83	1623
2400	1169	1.38	1229	1241	1.53	1359	1310	1.68	1493	1375	1.84	1633	1439	2.00	1778
2500	1212	1.55	1378	1281	1.70	1513	1348	1.86	1652	1412	2.02	1796	1473	2.19	1945

Fan Performance PGH060 — Horizontal Discharge Units; Standard Motor (Belt Drive)* (Cont.)

AIRFLOW CFM	EXTERNAL STATIC PRESSURE (in. wg)														
	1.2			1.4			1.6			1.8			2.0		
	Rpm	Bhp	Watts	Rpm	Bhp	Watts	Rpm	Bhp	Watts	Rpm	Bhp	Watts	Rpm	Bhp	Watts
1500	1247	0.98	873	1320	1.13	1002	1390	1.28	1137	1457	1.44	1280	1522	1.61	1430
1600	1270	1.07	952	1342	1.22	1083	1411	1.37	1221	1476	1.54	1365	1540	1.71	1517
1700	1295	1.17	1040	1365	1.32	1173	1432	1.48	1313	1497	1.64	1459	1559	1.82	1612
1800	1321	1.28	1137	1390	1.43	1273	1455	1.59	1415	1518	1.76	1563	1579	1.93	1718
1900	1348	1.40	1243	1415	1.56	1381	1479	1.72	1526	1541	1.89	1677	1601	2.06	1834
2000	1377	1.53	1359	1442	1.69	1500	1505	1.86	1648	1565	2.03	1801	1624	2.21	1961
2100	1406	1.67	1485	1470	1.83	1629	1531	2.00	1780	1591	2.18	1936	1648	2.36	2098
2200	1437	1.83	1621	1499	1.99	1769	1559	2.16	1923	1617	2.34	2082	—	—	—
2300	1468	1.99	1769	1529	2.16	1920	1587	2.34	2077	—	—	—	—	—	—
2400	1500	2.17	1928	1559	2.35	2083	—	—	—	—	—	—	—	—	—
2500	1533	2.36	2098	—	—	—	—	—	—	—	—	—	—	—	—

NOTES:

1. Gray cells indicate field-supplied drive is required.
2. Maximum continuous bhp is 2.40.
3. See general fan performance notes.

LEGEND

Bhp — Brake Horsepower
Watts — Input Watts to Motor
 *Motor drive range: 1035 to 1460 rpm. All other rpms require field-supplied drive.

TYPICAL INSTALLATIONS

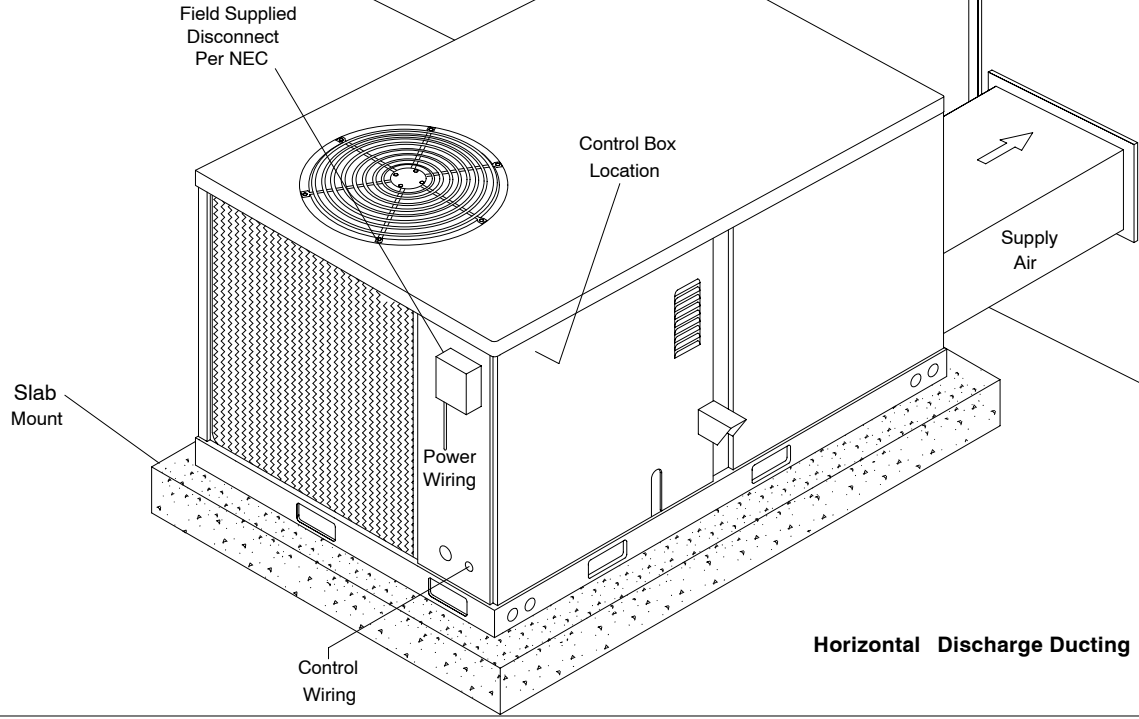

Horizontal Discharge Ducting

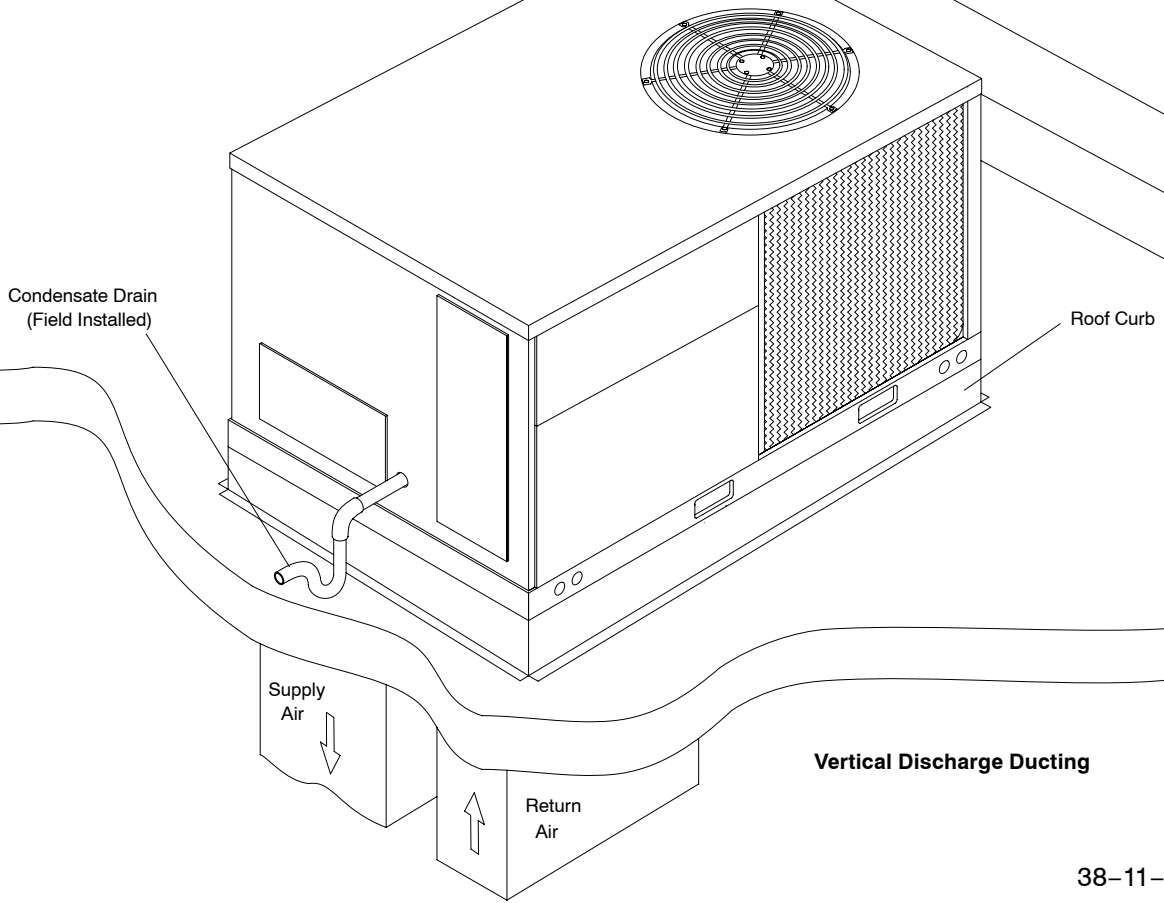

Vertical Discharge Ducting

38-11-37

ACCESSORIES: PGH036 – 060 (575 V Only)

ROOF CURBS

Description	Model Number	Where Used
8" High	AXB033CLA	3 - 5 Ton
14" High	AXB033CMA	3 - 5 Ton
24" High	AXB033CHA	3 - 5 Ton

CURB ADAPTORS (Used with AXB030C*A CURB)

Description	Model Number	Where Used
Without Ducts	AXB033CAA	3 - 5 Ton
With Ducts	AXB033CBA	3 - 5 Ton

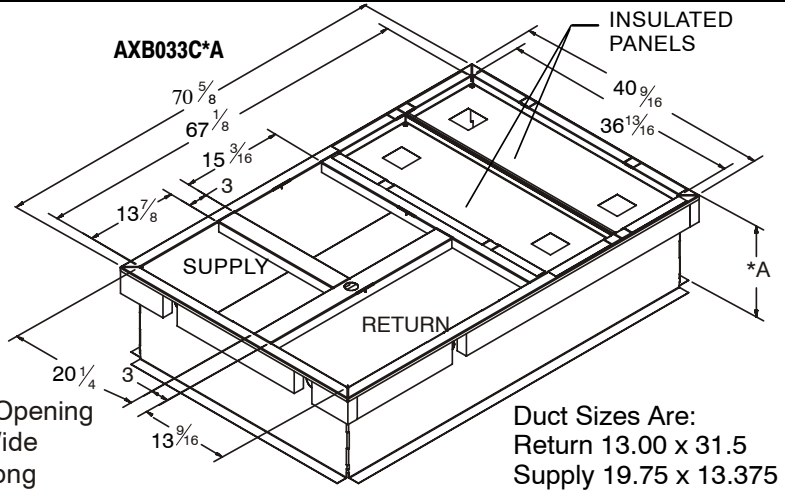
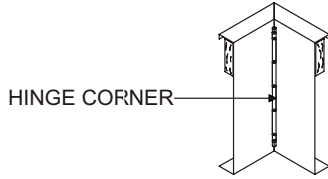

ECONOMIZER – DOWNFLOW

Description	Model Number	Where Used
Fully Modulating	AXB035EMA	3 - 5 Ton
Three Position	AXB035EPA	3 - 5 Ton
Three Position	DNECOMZR020A02 *	3 - 5 Ton

* Not Shown

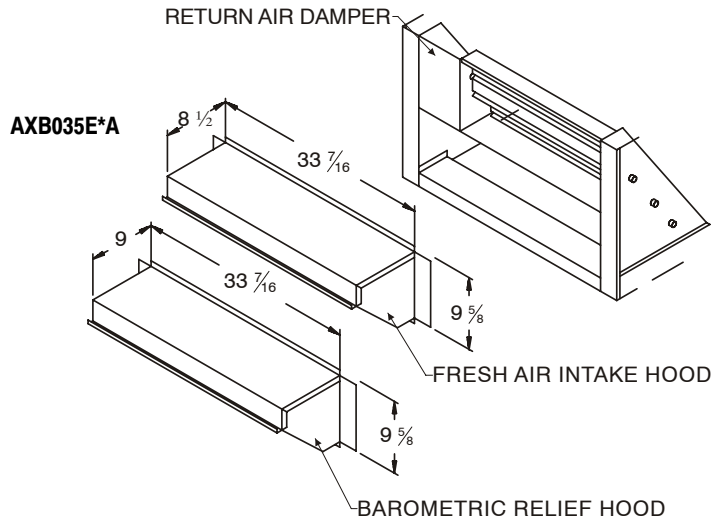

ECONOMIZER – HORIZONTAL

Description	Model Number	Where Used
Fully Modulating	AXB035HEA	3 - 5 Ton
Three Position	AXB035HPA	3 - 5 Ton
Three Position	DNECOMZR024A02 *	3 - 5 Ton

* Not Shown

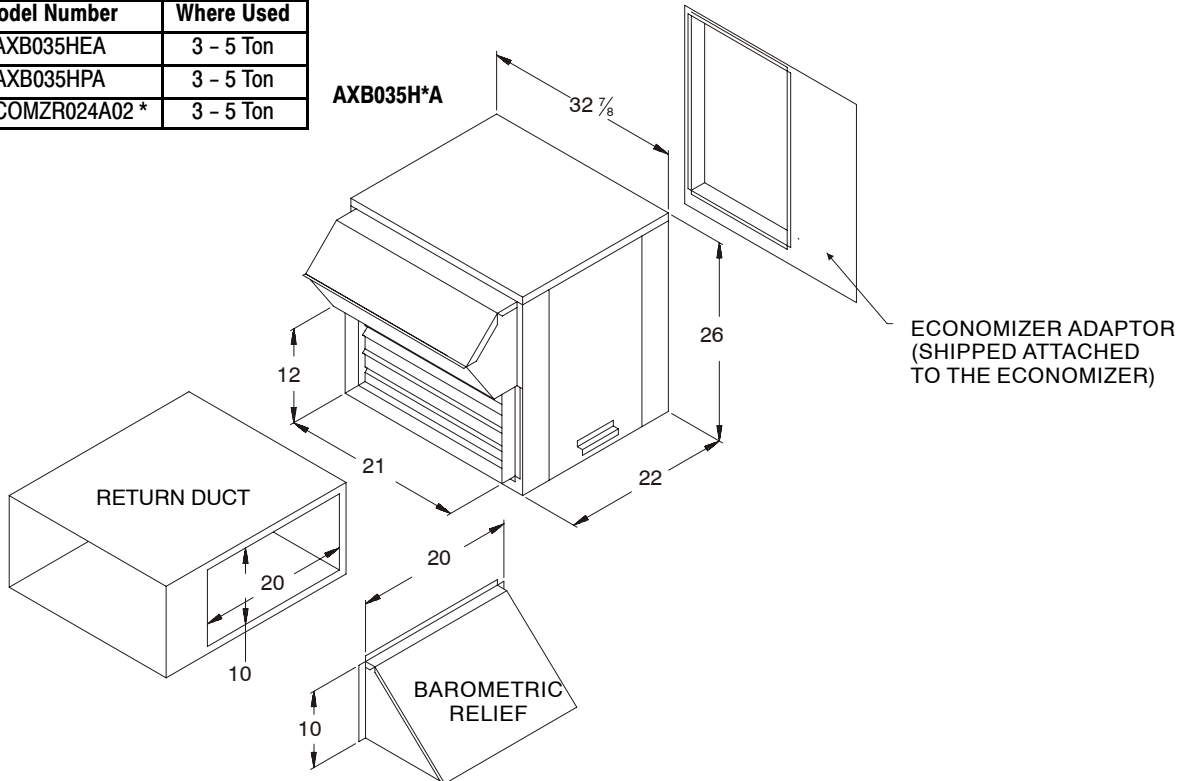

ACCESSORIES: PGH036 – 060 (575 V Only)

FRESH AIR DAMPER

Description	Model Number	Where Used
Manual	AXB035FAA	3 - 5 Ton
Motorized	AXB035FMA	3 - 5 Ton
Manual	DNMANDPR001A03*	3 - 5 Ton

* Not shown

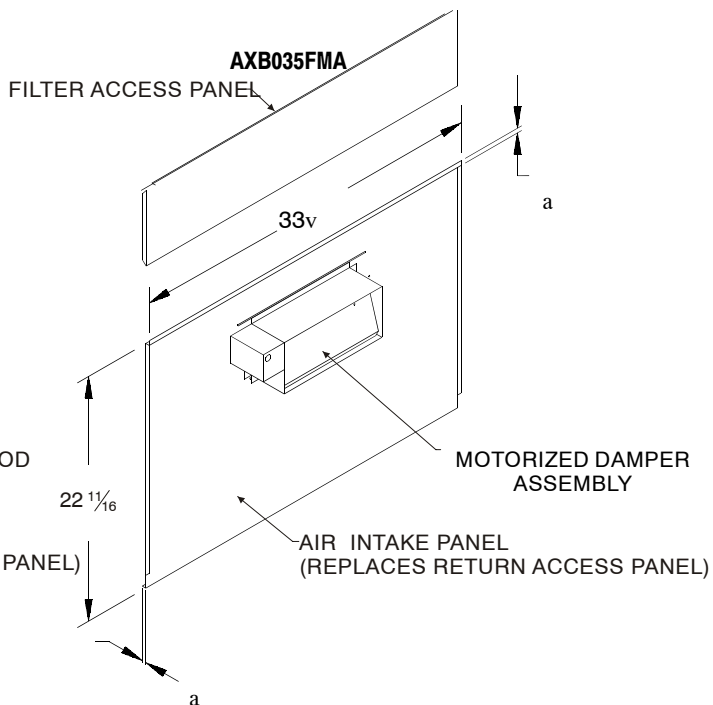
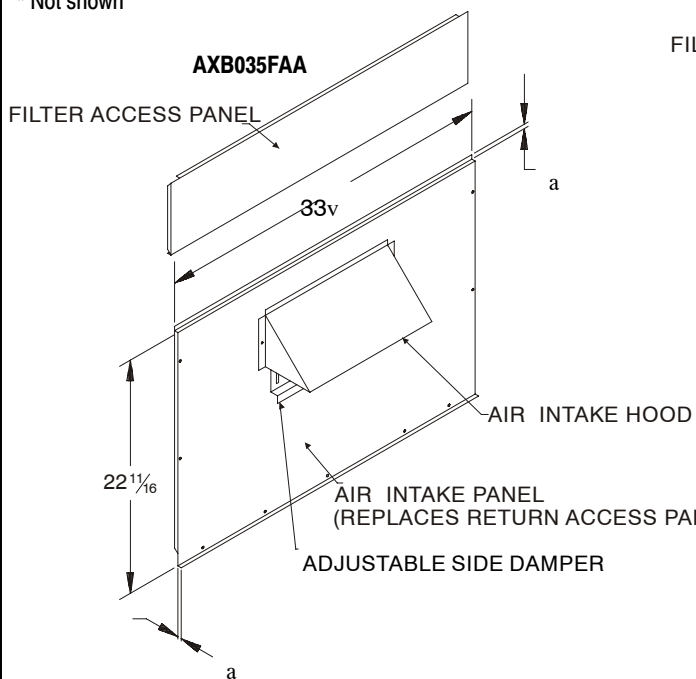

COIL PROTECTION

Description	Model Number	Where Used
Coil Guard	AXB033CGA	3 - 5 Ton
Hail Guard	AXB033HGA	3 - 5 Ton

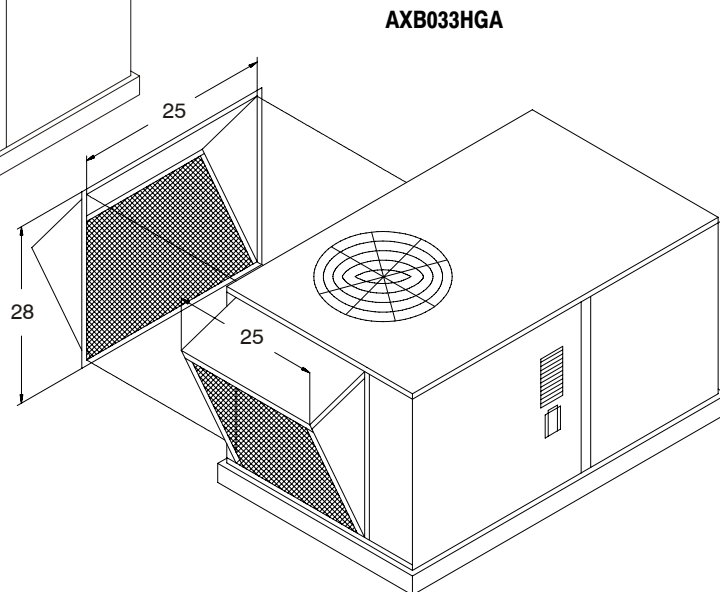
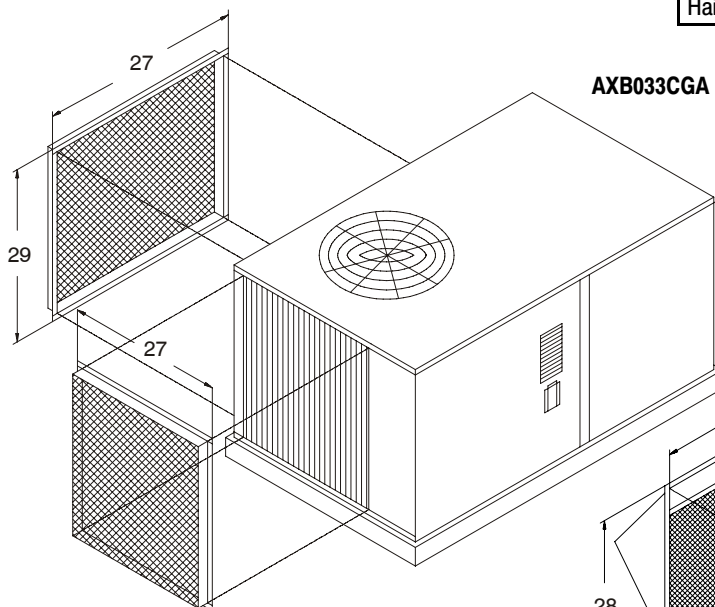

ACCESSORIES: PGH036 – 060 (575 V Only)

CONCENTRIC DUCT KIT

Description	Model Number	Where Used
20" Round.	AXB035CTA	3 – 5 Ton

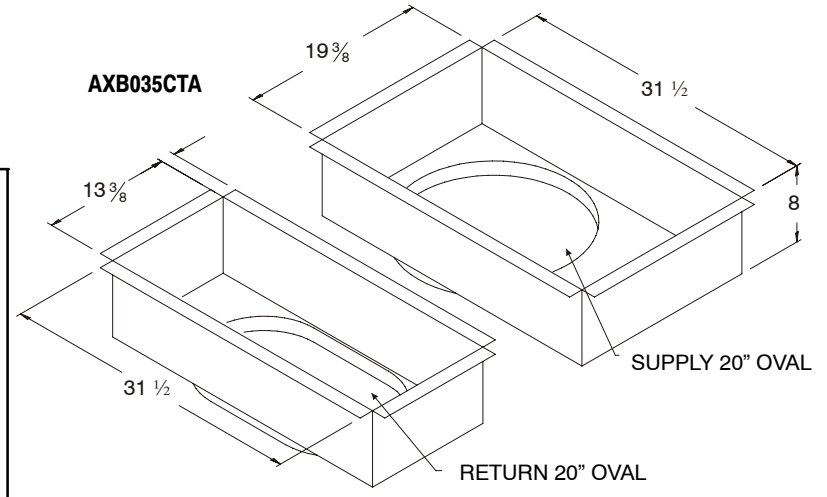

PERFORMANCE DATA ON NEXT PAGE

CONCENTRIC DIFFUSER

Description	Model Number	Used With
Flush Mount	AXB030CFA	3 – 5 Ton
Flush Mount	AXB040CFA	3 – 5 Ton
Step Down	AXB030CSA	3 – 5 Ton
Step Down	AXB040CSA	3 – 5 Ton

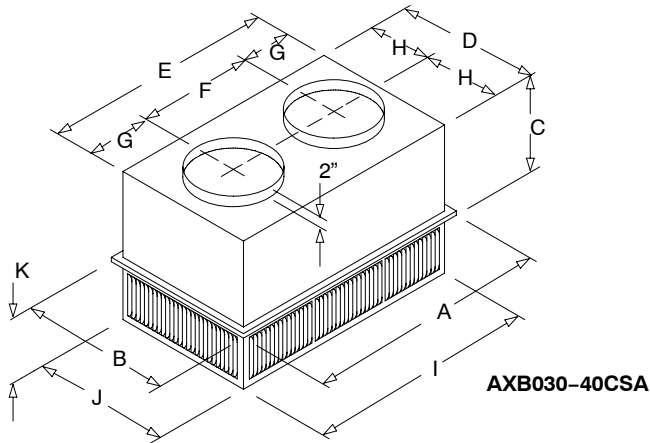

CONCENTRIC DIFFUSER (Step Down)

Model Number	A	B	C	D	E	F	G	H	I	J	K	Duct Size
AXB030CSA	47-5/8	23-5/8	11-3/8	21-1/2	45-1/2	22-1/2	11-1/2	10-3/4	45-1/2	21-1/2	7-1/8	18" RD
AXB040CSA	47-5/8	29-5/8	14-3/8	27-1/2	45-1/2	22-1/2	11-1/2	13-3/4	45-1/2	27-1/2	8-1/8	20" RD

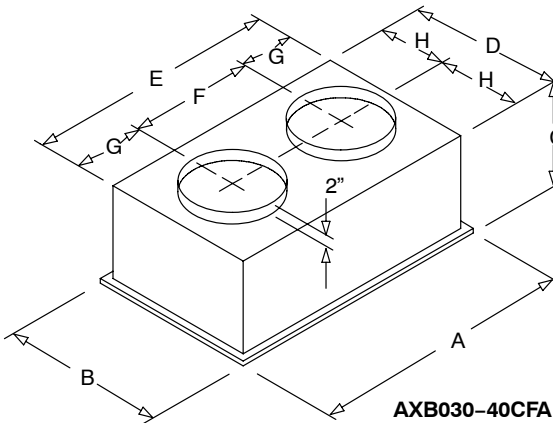

CONCENTRIC DIFFUSER (Flush Mount)

Model Number	A	B	C	D	E	F	G	H	Duct Size
AXB030CFA	47-5/8	23-5/8	13-1/2	21	45	22-1/2	11-1/4	10-1/2	18" RD
AXB040CFA	47-5/8	29-5/8	16-5/8	27	45	22-1/2	11-1/4	13-1/2	20" RD

ACCESSORIES: PGH036 – 060 (575 V Only)

CSA SERIES STEP-DOWN PERFORMANCE					
Part No. AXB	CFM	Static Pressure In. WC	Throw Feet	Neck / Jet Velocity FPM	db Sound Levels
030CSA	1200	.17	11-18	421	20
	1400	.20	12-19	491	20
	1600	.24	12-20	561	20
	1800	.30	13-21	632	20
	2000	.36	14-23	702	20
	2200	.40	16-25	772	20
040CSA	2600	.17	24-29	669	20
	2800	.20	25-30	720	25
	3000	.25	27-33	772	25
	3200	.31	28-35	823	25
	3400	.37	30-37	874	30

CFA SERIES FLUSH MOUNT PERFORMANCE						
Part No. AXB	CFM	Static Pressure In. WC	Throw Feet	Neck Velocity FPM	Jet Velocity FPM	db Sound Level
030CFA	1000	.14	15-20	391	694	20
	1200	.17	16-22	469	833	25
	1400	.20	17-24	547	972	30
	1600	.24	18-25	625	1111	30
	1800	.30	20-28	703	1250	35
	2000	.36	21-29	781	1389	40
	2200	.40	22-30	859	1528	40
	040CFA	2600	.17	19-24	663	1294
2800		.20	20-28	714	1393	35
3000		.25	21-29	765	1492	35
3200		.31	22-29	816	1592	40
3400		.37	22-30	867	1692	40

CSA/CFA NOTES:

1. All data is based on the Air Diffusion Council guidelines.
2. Throw data is based on Terminal Velocities of 75 FPM using isothermal air.
3. Throw is based on diffuser blades being directed in a straight pattern.
4. Actual sound levels are less than those shown.
5. Minimum height 9' above floor.

LOW AMBIENT CONTROLS		
Model Number	Description	Used With
AXB035LAA	Low Ambient Kit (0 Deg. F)	3 - 5 Ton
WINTER START KIT		
Model Number	Description	Used With
DNWINSTR001A00	Low pressure switch bypass (time delay)	3 - 5 Ton
PHASE MONITOR CONTROL		
Model Number	Description	Used With
DNPHASE3001A01	Electronic phase monitor breaks "R" control signal if trouble is detected	3 - 5 Ton
THROUGH-THE-BOTTOM CURB/POWER CONNECTION		
Model Number	Description	Used With
DNBTMPWR001A01	Thru-the-bottom electrical + thru--the curb Gas	3 - 5 Ton
DNBTMPWR003A01	Thru-the-bottom electrical and Gas (AXB035PKA)	3 - 5 Ton
ECONOMIZER SENSORS*		
Model Number	Description	Used With
DNTEMPSN002A00	Single or Differential Temp (dry bulb) Control	ALL Economizers With W7212 Controller
DNCBDIOX005A00	Single or Differential Temp (dry bulb) Control	ALL Economizers With W7212 Controller
DNENTDIF004A00	Return Air Enthalpy Sensor	ALL Economizers With W7212 Controller
AXB078ENT	Enthalpy Control	3 - 5 Ton
*For use with "DN" model economizers		
ANTI-CYCLE TIMER		
Model Number	Description	Used With
DNTIMEGD001A00	Five minute compressor delay	3 - 5 Ton
PROPANE GAS CONVERSION KITS		
Model Number	Description	Used With
AXB035LPA	Natural to LP Conversion Kit	3 - 5 Ton
DNNGHIAT003A00	High Altitude Nat. Gas Kit (2,000' - 7,000')	3 - 5 Ton

ACCESSORIES: PGH036 – 060 (575 V Only)

POWER EXHAUST

Description	Model Number	Where Used
575 Volt	AXB035PES	3 - 5 Ton

POWER EXHAUST PERFORMANCE DATA

Model	Volt/Phase/ Hertz	Motor			Unit									
		Qty	HP	RPM	Cir. Qty	LRA	FLA	MCA	Fuse Size	@0.0		@0.3		
										CFM	RPM	CFM	RPM	
AXB035PES	575/1/60	1	1	1625	1	4.1	1.7	2.2	4	2300	1625	2000	1625	

NOTE: Power exhaust is wired single phase, drop third leg when installing.

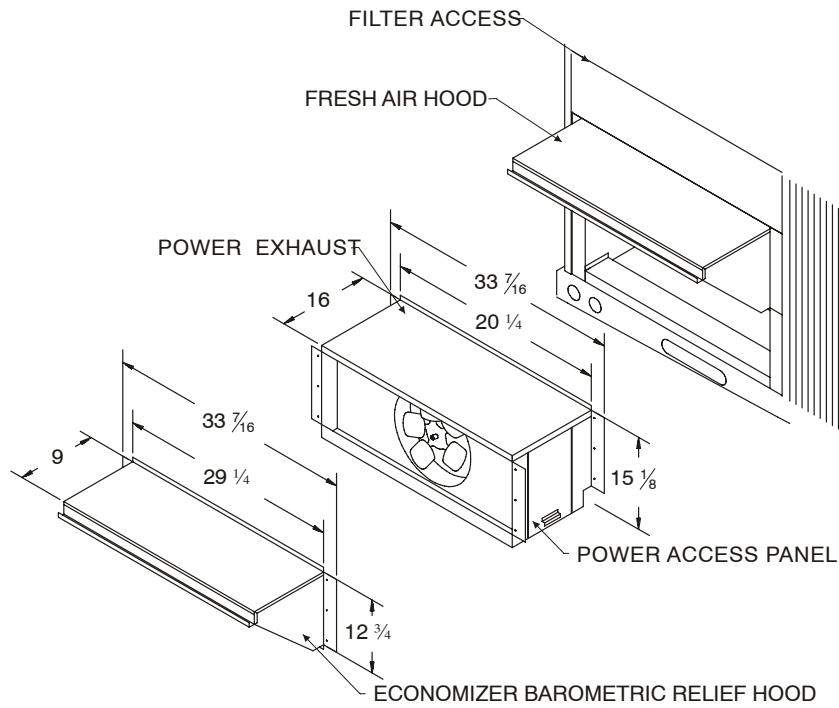

OPERATING SEQUENCE

Cooling, Units Without Economizer When thermostat calls for cooling, terminals G and Y1 are energized. The indoor–fan contactor (IFC) and compressor contactor are energized and indoor–fan motor, compressor, and outdoor fan starts. The outdoor–fan motor runs continuously while unit is cooling.

Heating, Units Without Economizer When the thermostat calls for heating, terminal W1 is energized. To prevent thermostat short–cycling, the unit is locked into the Heating mode for at least 1 minute when W1 is energized. The induced–draft motor is energized and the burner ignition sequence begins. The indoor (evaporator) fan motor (IFM) is energized 45 seconds after a flame is ignited. On units equipped for two stages of heat, when additional heat is needed, W2 is energized and the high–fire solenoid on the main gas valve (MGV) is energized.

When the thermostat is satisfied and W1 is deenergized, the IFM stops after a 45–second time–off delay.

APPLICATION DATA

- 1. DUCTWORK** Secure vertical discharge ductwork to roof curb. For horizontal discharge applications, attach ductwork to unit, or field–supplied flanges can be attached to horizontal discharge openings and all ductwork attached to flanges.
- 2. THRU–THE–BOTTOM UTILITY CONNECTIONS** An accessory kit is required for proper installation of thru–the–bottom connections.
- 3. THERMOSTAT** Use of 2–stage cooling thermostat is recommended for all units with an economizer.
- 4. HEATING–TO–COOLING CHANGEOVER** All units are automatic changeover from heating to cooling when automatic changeover thermostat and subbase are used.
- 5. AIRFLOW** Units are draw–thru on cooling and blow–thru on heating.
- 6. MAXIMUM AIRFLOW** To minimize the possibility of condensate blow–off from evaporator, airflow through units should not exceed 500 cfm/ton.
- 7. MINIMUM AIRFLOW** The minimum airflow for cooling is 300 cfm/ton.
- 8. MINIMUM AMBIENT COOLING OPERATION TEMPERATURE** The cooling temperature for all units is 25 F.
- 9. MAXIMUM OPERATING OUTDOOR–AIR TEMPERATURE** For cooling, this temperature is 125 F.
- 10. HIGH ALTITUDE** A change to the gas orifice may be required at high altitudes. Refer to Altitude Compensation charts.
- 11. MINIMUM TEMPERATURE** Air entering the heat exchanger in heating must be a minimum of 50 F continuous and 45 F intermittent.
- 12. INTERNAL UNIT DESIGN** Due to the PGH internal unit design (draw–thru over the motor), air path, and specially designed motors, the full horsepower (maximum continuous bhp) listed in the Physical Data table and the notes following each Fan Performance table can be utilized with extreme confidence. Using PGH motors with the values listed in the Physical and Fan Performance Data tables will not result in nuisance tripping or premature motor failure. The unit warranty will not be affected.

CABINET:

The cabinet shall be made of sturdy baked enamel coated galvanized steel. Base rails shall be 16 gauge steel and have fork lift slots and holes provided for lifting shackles. Unit shall be designed with convertible airflow and shipped ready for downflow applications with conversion to horizontal air flow accomplished by relocating two panels.

Return air compartments shall be insulated with not less than 1/2" of water resistant coated glass fiber and not less than 1/2" of aluminum foil faced glass fiber in the furnace/supply compartments.

COOLING SECTION:

Units shall be factory charged and operationally ready. Each refrigeration circuit shall have a compressor, with internal overload protection, high and low pressure switches, filter drier and copper tube/aluminum fin evaporator and condenser coils.

Units shall be capable of cooling operation down to 25°F as shipped from the factory.

COILS:

The evaporator and condenser coils shall be fabricated with aluminum fins mechanically bonded to copper tubing. Both coils shall be pressure tested prior to assembly into the unit and electronically leak tested after assembly onto the unit. The evaporator coil shall be protected from dust and debris on the return air side by factory installed 2" air filters.

CONDENSER FAN:

The unit shall have a single direct drive propeller fan/motor assembly mounted directly to a vertical–discharge grille panel that is easily removable. Motors shall have permanently lubricated sleeve bearings and inherent overload protection.

EVAPORATOR BLOWER:

The units shall have a single belt driven evaporator blower. The motor shall have permanently lubricated ball bearings and internal overload protection. An adjustable motor drive sheave for matching air flow requirements shall be standard.

HEATING SECTION:

The units shall have aluminized steel tubular heat exchangers located on the discharge side of the evaporator blower and equipped with a two–stage gas valve. The units shall have in–shot burners that are ignited by an electronic spark with flame proving feature and protected by both a limit switch and flame roll–out switch.