

INSTALLATION INSTRUCTIONS

R-410A Single Package Heat Pumps

PHD524-60

Single Phase

These instructions must be read and understood completely before attempting installation

Safety Labeling and Signal Words

DANGER, WARNING, CAUTION, and NOTE

The signal words **DANGER**, **WARNING**, **CAUTION**, and **NOTE** are used to identify levels of hazard seriousness. The signal word **DANGER** is only used on product labels to signify an immediate hazard. The signal words **WARNING**, **CAUTION**, and **NOTE** will be used on product labels and throughout this manual and other manual that may apply to the product.

DANGER - Immediate hazards which will result in severe personal injury or death.

WARNING - Hazards or unsafe practices which could result in severe personal injury or death.

CAUTION - Hazards or unsafe practices which may result in minor personal injury or product or property damage.

NOTE - Used to highlight suggestions which will result in enhanced installation, reliability, or operation.

Signal Words in Manuals

The signal word **WARNING** is used throughout this manual in the following manner:

 **WARNING**

The signal word **CAUTION** is used throughout this manual in the following manner:

 **CAUTION**

Signal Words on Product Labeling

Signal words are used in combination with colors and/or pictures or product labels.

TABLE OF CONTENTS Page

| | |
|---|----|
| SAFETY CONSIDERATIONS | 2 |
| RECEIVING AND INSTALLATION | 2 |
| Step 1 - Check Equipment | 2 |
| Step 2 - Provide Unit Support | 2 |
| Step 3 - Provide Clearances | 3 |
| Step 4 - Rig and Place Unit | 3 |
| Step 5 - Select and Install Duct Connections | 3 |
| Step 6 - Provide for Condensate Disposal | 8 |
| Step 7 - Install Electrical Connections | 9 |
| PRE-START-UP | 15 |
| START-UP | 15 |
| Check Cooling and Electric Heat | 15 |
| Check for Refrigerant Leaks | 15 |
| Start-Up Adjustments | 16 |
| Maintenance | 19 |
| Troubleshooting | 24 |
| Start-Up Checklist | 27 |

 **WARNING**

PERSONAL INJURY, AND/OR PROPERTY DAMAGE HAZARD

Failure to carefully read and follow this warning could result in equipment malfunction, property damage, personal injury and/or death.

Installation or repairs made by unqualified persons could result in equipment malfunction, property damage, personal injury and/or death.

The information contained in this manual is intended for use by a qualified service technician familiar with safety procedures and equipped with proper tools and test instruments.

Installation must conform with local building codes and with the national Electrical Code NFPA70 current edition or Canadian Electrical Code part 1 CSA C.22.1.

SAFE INSTALLATION REQUIREMENTS

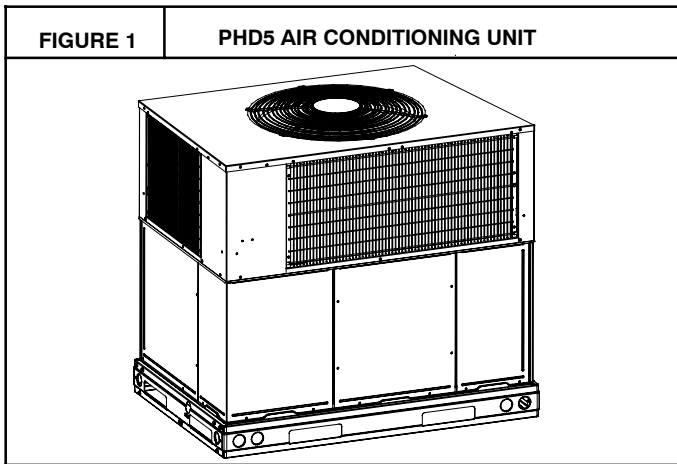

Improper installation, adjustment, alteration, service, maintenance, or use can cause explosion, fire, electrical shock, or other conditions which may cause death, personal injury, or property damage. Consult a qualified installer, service agency, or your distributor or branch for information or assistance. The qualified installer or agency must use factory-authorized kits or accessories when modifying this product. Refer to the individual instructions packaged with the kits or accessories when installing.

Follow all safety codes. Wear safety glasses, protective clothing, and work gloves. Use quenching cloth for brazing operations. Have a fire extinguisher available. Read these instructions thoroughly and follow all warnings or cautions included in literature and attached to the unit. Consult local building codes, the current editions of the National Electrical Code (NEC) NFPA 70.

In Canada refer to the current editions of the Canadian electrical Code CSA C22.1.

Recognize safety information. This is the safety-alert symbol . When you see this symbol in instructions or manuals, be alert to the potential for personal injury.

Understand the signal words **DANGER**, **WARNING**, **CAUTION**, and **NOTE**. These words are used with the safety-alert symbol. **DANGER** identifies the most serious hazards which **will** result in serious injury or death. **WARNING** signifies a hazard which **could** result in serious injury or death. **CAUTION** is used to identify unsafe practices which **may** result in minor personal injury or product and property damage. **NOTE** is used to highlight suggestions which **will** result in enhanced installation, reliability, or operation.

WARNING

ELECTRICAL SHOCK HAZARD

Failure to follow this warning could result in personal injury or death.

Before installing or servicing system, turn off power supply to the unit and install lockout tag. There may be more than one disconnect switch. Turn off accessory heater power switch if applicable.

WARNING

UNIT OPERATION AND SAFETY HAZARD

Failure to follow this warning could result in personal injury or equipment damage.

R-410A systems operate at higher pressures than standard R-22 systems. **DO NOT** use R-22 service equipment or components on R-410A equipment. Ensure service equipment is rated for R-410A.



CAUTION

CUT HAZARD

Failure to follow this caution may result in personal injury.

When removing access panels (see Fig. 18) or performing maintenance functions inside your unit, be aware of sharp sheetmetal parts and screws. Although special care is taken to reduce sharp edges to a minimum, be extremely careful when handling parts or reaching into the unit.

INTRODUCTION

This packaged heat pump unit is fully self-contained and designed for outdoor installation (see Fig. 1). See Fig. 4 and 5 for unit dimensions. Standard units are shipped in a horizontal-discharge configuration for installation on a ground level slab. Standard units can be converted to downflow (vertical) discharge configurations for rooftop applications.

RECEIVING AND INSTALLATION

Step 1—Check Equipment

IDENTIFY UNIT

The unit model number and serial number are stamped on the unit information plate. Check this information against shipping papers.

INSPECT SHIPMENT

Inspect for shipping damage before removing packaging materials. If unit appears to be damaged or is torn loose from its anchorage, have it examined by transportation inspectors before removal. Forward claim papers directly to transportation company. Manufacturer is not responsible for any damage incurred in transit. Check all items against shipping list. Immediately notify the nearest equipment distribution office if any item is missing. To prevent loss or damage, leave all parts in original packages until installation.

Step 2—Provide Unit Support

IMPORTANT: The unit must be secured to the curb by installing screws through the bottom of the curb flange and into the unit base rails. When installing large base units onto the common curb, the screws must be installed before allowing the full weight of the unit to rest on the curb. A minimum of six screws are required for large base units. Failure to secure unit properly could result in an unstable unit. See Warning near Rigging/Lifting information and accessory curb instructions for more details.

For hurricane tie downs, contact distributor for details and PE (Professional Engineering) Certificate if required.

Roof Curb

Install accessory roof curb in accordance with instructions shipped with curb. See Fig. 6. Install insulation, cant strips, roofing, and flashing. Ductwork must be attached to curb.

IMPORTANT: The gasketing of the unit to the roof curb is critical for a water tight seal. Install gasketing material supplied with the roof curb. Improperly applied gasketing also can result in air leaks and poor unit performance.

Curb should be level to within 1/4" (6mm). This is necessary for unit drain to function properly. Refer to accessory roof curb installation instructions for additional information as required.

Accessory kits are available to aid in installing a new metal base rail unit on an old roof curb.

Accessory kit number CPADCURB001A00, (small chassis) and accessory kit number CPADCURB002A00, (large chassis) includes roof curb adapter and gaskets for the perimeter seal and duct openings. No additional modifications to curb are required when using this kit.

Slab Mount

Place the unit on a solid, level concrete pad that is a minimum of 4" (102mm) thick with 2" (51mm) above grade (see Figure 2). The slab should extend approximately 2" beyond the casing on all 4 sides of the unit. Do not secure the unit to the slab *except* when required by local codes.

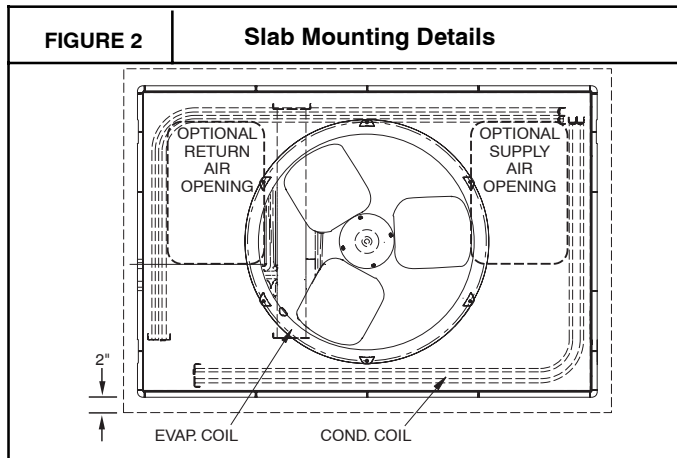

Step 3—Provide Clearances

The required minimum service clearances are shown in Fig. 4 and 5. Adequate ventilation and outdoor air must be provided. The outdoor fan draws air through the outdoor coil and discharges it through the top fan grille. Be sure that the fan discharge does not recirculate to the outdoor coil. Do not locate the unit in either a corner or under an overhead obstruction. The minimum clearance under a partial overhang (such as a normal house overhang) is 48 in. (1219mm) above the unit top. The maximum horizontal extension of a partial overhang must not exceed 48 in. (1219mm).

IMPORTANT: Do not restrict outdoor airflow. An air restriction at either the outdoor-air inlet or the fan discharge may be detrimental to compressor life.

Do not place the unit where water, ice, or snow from an overhang or roof will damage or flood the unit. Do not install the unit on carpeting or other combustible materials. Slab-mounted units should be at least 4 in. (102mm) above the highest expected water and runoff levels. Do not use unit if it has been under water.

Step 4—Rig and Place Unit

Rigging and handling of this equipment can be hazardous for many reasons due to the installation location (roofs, elevated structures, etc.).

Only trained, qualified crane operators and ground support staff should handle and install this equipment.

When working with this equipment, observe precautions in the literature, on tags, stickers, and labels attached to the equipment, and any other safety precautions that might apply.

Training for operators of the lifting equipment should include, but not be limited to, the following:

1. Application of the lifter to the load, and adjustment of the lifts to adapt to various sizes or kinds of loads.
2. Instruction in any special operation or precaution.
3. Condition of the load as it relates to operation of the lifting kit, such as balance, temperature, etc.

Follow all applicable safety codes. Wear safety shoes and work gloves.

INSPECTION

Prior to initial use, and at monthly intervals, all rigging shackles, clevis pins, and straps should be visually inspected for any damage, evidence of wear, structural deformation, or cracks. Particular attention should be paid to excessive wear at hoist hooking points and load support areas. Materials showing any kind of wear in these areas must not be used and should be discarded.

⚠ WARNING

UNIT FALLING HAZARD

Failure to follow this warning could result in personal injury or death.

Never stand beneath rigged units or lift over people.

Rigging/Lifting of Unit

⚠ WARNING

UNIT FALLING HAZARD

Failure to follow this warning could result in personal injury/death or property damage.

When straps are taut, the clevis should be a minimum of 36 in. (914 mm) above the unit top cover.

⚠ WARNING

UNIT FALLING HAZARD

Failure to follow this warning could result in personal injury or death.

Large base units must be secured to common curb before allowing full weight of unit to rest on curb. Install screws through curb into unit base rails while rigging crane is still supporting unit.

Lifting holes are provided in base rails as shown in Fig. 4 and 5.

1. Leave top shipping skid on the unit for use as a spreader bar to prevent the rigging straps from damaging the unit. If the skid is not available, use a spreader bar of sufficient length to protect the unit from damage.
2. Attach shackles, clevis pins, and straps to the base rails of the unit. Be sure materials are rated to hold the weight of the unit (See Fig. 3).
3. Attach a clevis of sufficient strength in the middle of the straps. Adjust the clevis location to ensure unit is lifted level with the ground.

After the unit is placed on the roof curb or mounting pad, remove the top crating.

Step 5—Select and Install Duct Connections

The design and installation of the duct system must be in accordance with the standards of the NFPA for installation of non-residence type air conditioning and ventilating systems, NFPA 90A or residence type, NFPA 90B and/or local codes and ordinances.

Select and size ductwork, supply-air registers, and return air grilles according to ASHRAE (American Society of Heating, Refrigeration, and Air Conditioning Engineers) recommendations.

The unit has duct flanges on the supply- and return-air openings on the side of the unit.

⚠ WARNING

PROPERTY DAMAGE HAZARD

Failure to follow this warning could result in personal injury/death or property damage.

For vertical supply and return units, tools or parts could drop into ductwork. Install a 90 degree turn in the return ductwork between the unit and the conditioned space. If a 90 degree elbow cannot be installed, then a grille of sufficient strength and density should be installed to prevent objects from falling into the conditioned space. Units with electric heaters require 90 degree elbow in supply duct.

When designing and installing ductwork, consider the following:

1. All units should have field-supplied filters or accessory filter rack installed in the return-air side of the unit. Recommended sizes for filters are shown in Table 1.
2. Avoid abrupt duct size increases and reductions. Abrupt change in duct size adversely affects air performance.

IMPORTANT: Use flexible transitions between ductwork and unit to prevent transmission of vibration. Use suitable gaskets to ensure weather tight and airtight seal. When electric heat is installed, use fireproof canvas (or similar heat resistant material) connector between ductwork and unit discharge connection. If flexible duct is used, insert a sheet metal sleeve inside duct. Heat resistant duct connector (or sheet metal sleeve) must extend 24-in. (610mm) from electric heater element.

3. Size ductwork for cooling air quantity (cfm). The minimum air quantity for proper electric heater operation is listed in Table 2. Heater limit switches may trip at air quantities below those recommended.
4. Seal, insulate, and weatherproof all external ductwork. Seal, insulate and cover with a vapor barrier all ductwork passing through conditioned spaces. Follow latest Sheet Metal and Air Conditioning Contractors National Association (SMACNA) and Air Conditioning Contractors Association (ACCA) minimum installation standards for residential heating and air conditioning systems.
5. Secure all ducts to building structure. Flash, weatherproof, and vibration-isolate duct openings in wall or roof according to good construction practices.

FIGURE 3

Unit Corner Weight (lbs) and Rigging

⚠ CAUTION - NOTICE TO RIGGERS ⚠ PRUDENCE - AVIS AUX MANIPULATEUR

ACCESS PANELS MUST BE IN PLACE WHEN RIGGING.
PANNEAUX D'ACCES DOIT ÊTRE EN PLACE POUR MANIPULATION.

Use top skid as spreader bar. / Utiliser la palette du haut comme barre de répartition

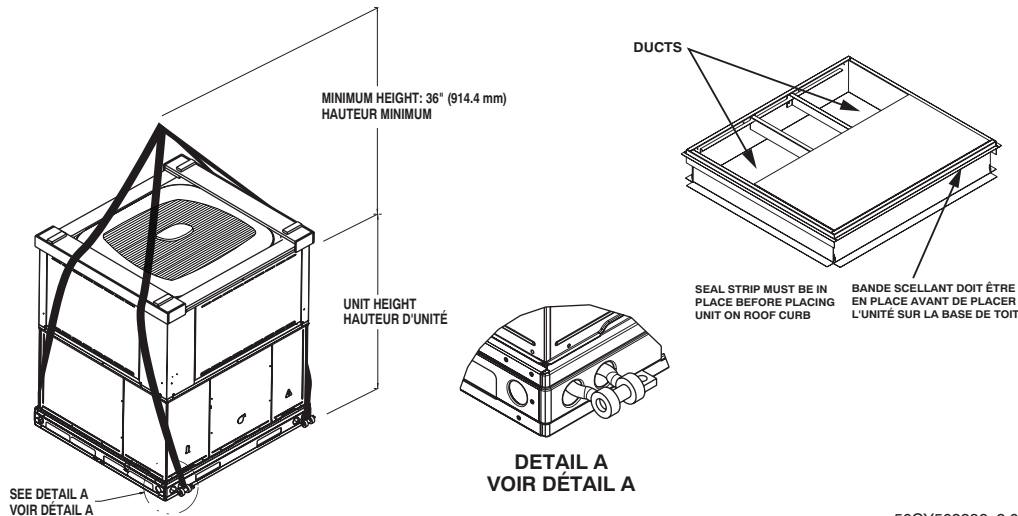

50CY502286 2.0

| Cabinet | MODEL NUMBER | Rigging Weight | |
|---------|--------------|----------------|-----|
| | | lb | kg |
| Small | PHD524 | 435 | 197 |
| Large | PHD536 | 501 | 227 |
| | PHD548 | 529 | 240 |
| | PHD560 | 572 | 259 |

FIGURE 4 PHD524 DIMENSIONS

| Unit | Electrical Characteristics | | Unit WT. | | Unit HT. | | | | Center of Gravity | | | |
|------|----------------------------|--------------|----------|------|----------|-------|------|-------|-------------------|-------|--------|-------|
| | 24 | 208/230-1-60 | LB | KG | A | X | Y | Z | 14-3/4 | 374.7 | 16-5/8 | 422.3 |
| 24 | 208/230 | 85.6 | 38.8 | 68.4 | 31.1 | 102.7 | 46.6 | 171.7 | 77.7 | | | |

| UNIT | Corner Weight LB/KG | | | | | | | | |
|------|---------------------|------|------|------|------|-------|------|-------|------|
| | 1 | 2 | 3 | 4 | | | | | |
| 24 | 208/230 | 85.6 | 38.8 | 68.4 | 31.1 | 102.7 | 46.6 | 171.7 | 77.7 |

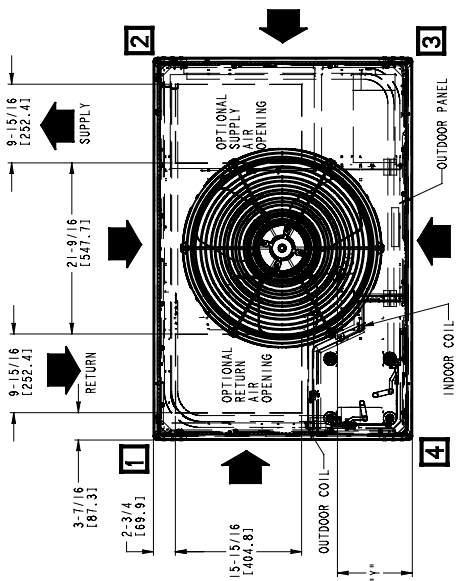

REQUIRED CLEARANCES TO COMBUSTIBLE MATL.

INCHES [MM]

TOP OF UNIT.....12 [305.6]

DOE SIDE OF UNIT.....14 [355.6]

SIDE OPPOSITE DUCTS.....14 [355.6]

BOTTOM OF UNIT.....0 [0.0]

ELECTRICAL PANEL.....36 [914.4]

NEC. REQUIRED CLEARANCES.

INCHES [MM]

BETWEEN UNITS, POWER ENTRY SIDE.....42 [1066.8]

UNIT AND UNGROUNDED SURFACES, POWER ENTRY SIDE.....36 [914.4]

UNIT AND BLOCK OR CONCRETE WALLS AND OTHER GROUNDED SURFACES, POWER ENTRY SIDE.....42 [1066.8]

REQUIRED CLEARANCE FOR OPERATION AND SERVICING

INCHES [MM]

EVAP. COIL ACCESS SIDE.....36 [914.4]

POWER ENTRY SIDE.....42 [1066.8]

(EXCEPT FOR NEC REQUIREMENTS)

SIDE OPPOSITE DUCTS.....48 [1219.2]

SIDE OPPOSITE DUCTS.....36 [914.4]

DUCT PANEL.....12 [304.8]

*MINIMUM DISTANCES: IF UNIT IS PLACED LESS THAN 12 [304.8] FROM WALL SYSTEM, THEN SYSTEM PERFORMANCE MAYBE COMPROMISED.

DIMENSIONS IN [] ARE IN MILLIMETERS

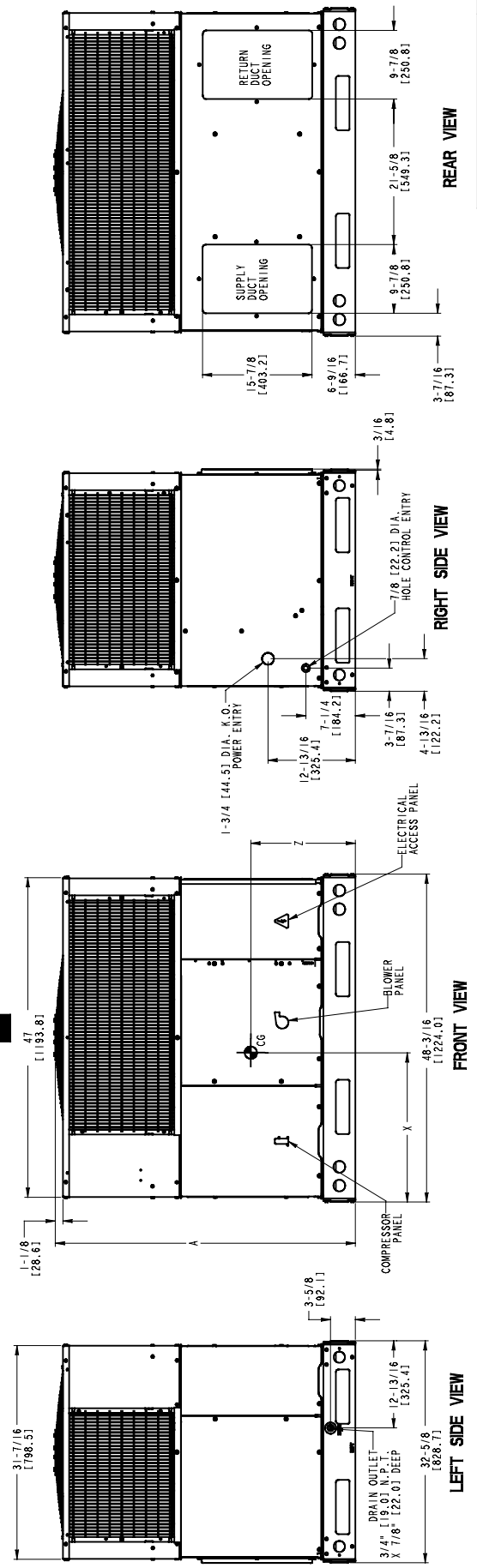

50VT500186
REV 2.0

FIGURE 5 PHD536-60 DIMENSIONS

| Unit | Electrical Characteristics | | Unit WT. | | Unit HT. | | | | Center of Gravity | | | |
|------|----------------------------|------|----------|-------|----------|--------|--------|-------|-------------------|-------|--------|-------|
| | LB | KG | A | X | Y | Z | Y | X | Z | | | |
| 36 | 208/230 | 1-60 | 492 | 223.3 | 48-3/4 | 1238.3 | 19-1/2 | 495.3 | 16-1/2 | 419.1 | 16-5/8 | 422.3 |
| 48 | 208/230 | 1-60 | 520 | 236.0 | 50-3/4 | 1289.1 | 19-1/2 | 495.3 | 16-1/2 | 419.1 | 17-5/8 | 447.7 |
| 60 | 208/230 | 1-60 | 563 | 255.5 | 54-3/4 | 1390.7 | 19-1/2 | 495.3 | 16-1/2 | 419.1 | 18 | 457.2 |

| UNIT | Corner Weight LB/KG | | | | | | | | |
|------|---------------------|-------|------|------|------|-------|------|-------|-------|
| | 1 | 2 | 3 | 4 | | | | | |
| 36 | 208/230 | 98.4 | 44.7 | 78.8 | 35.8 | 118.1 | 53.6 | 196.9 | 89.4 |
| 48 | 208/230 | 104.0 | 47.2 | 83.2 | 37.8 | 124.9 | 56.7 | 208.1 | 94.5 |
| 60 | 208/230 | 112.6 | 51.1 | 90.1 | 40.9 | 135.2 | 61.4 | 225.3 | 102.3 |

REQUIRED CLEARANCES TO COMBUSTIBLE MATL.

INCHES (MM)

TOP OF UNIT.....14 [355.6]

DUCT SIDE OF UNIT.....2 [50.8]

SIDE OPPOSITE DUCTS.....14 [355.6]

BOTTOM OF UNIT.....0 [0.0]

ELECTRICAL PANEL.....36 [914.4]

NEC. REQUIRED CLEARANCES.

INCHES (MM)

BETWEEN UNITS, POWER ENTRY SIDE.....42 [1066.8]

UNIT AND UNGROUNDED SURFACES, POWER ENTRY SIDE.....36 [914.0]

UNIT AND BLOCK OR CONCRETE WALLS AND OTHER GROUNDED SURFACES, POWER ENTRY SIDE.....42 [1066.8]

REQUIRED CLEARANCE FOR OPERATION AND SERVICING

INCHES (MM)

EVAP. COIL ACCESS SIDE.....36 [914.0]

POWER ENTRY SIDE.....42 [1066.8]

EXCEPT FOR NEC REQUIREMENTS)

UNIT TOP.....48 [1219.2]

SIDE OPPOSITE DUCTS.....36 [914.0]

DUCT PANEL.....12 [304.8]

*MINIMUM DISTANCES: IF UNIT IS PLACED LESS THAN 12 [304.8] FROM WALL SYSTEM, THEN SYSTEM PERFORMANCE MAYBE COMPROMISED.

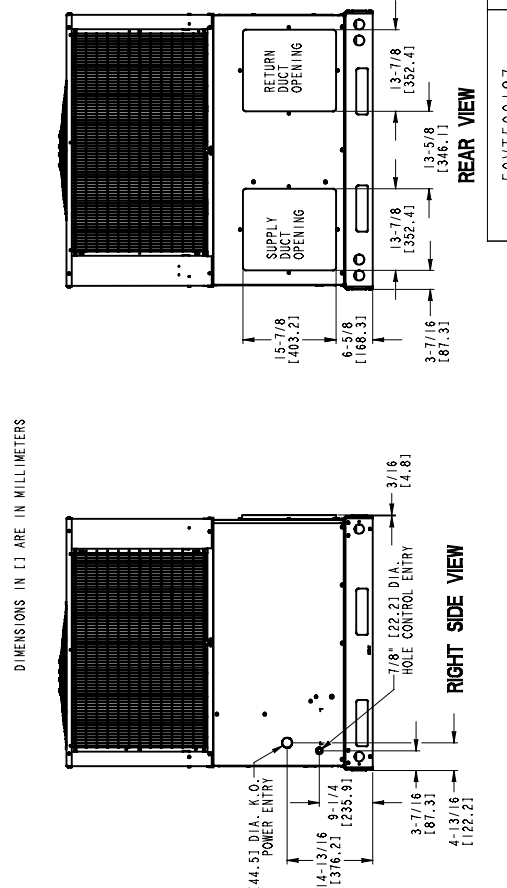
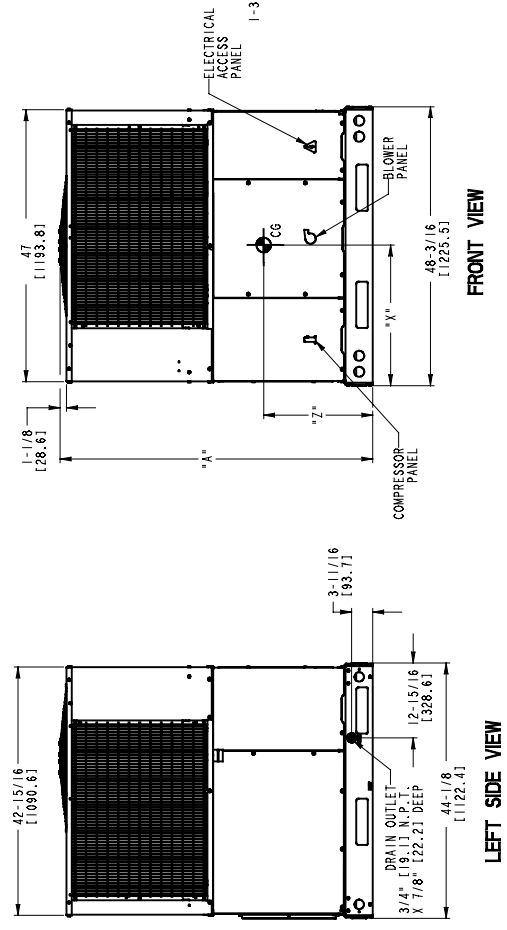
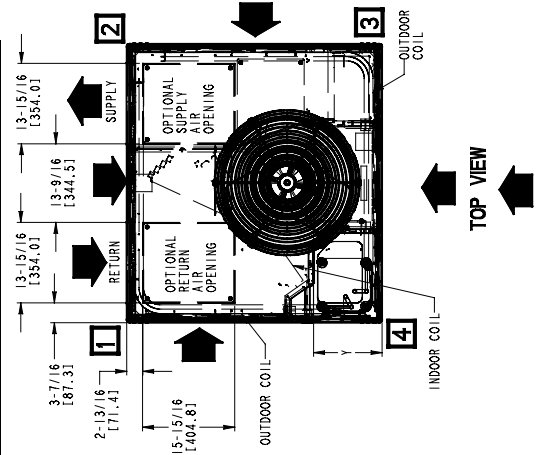
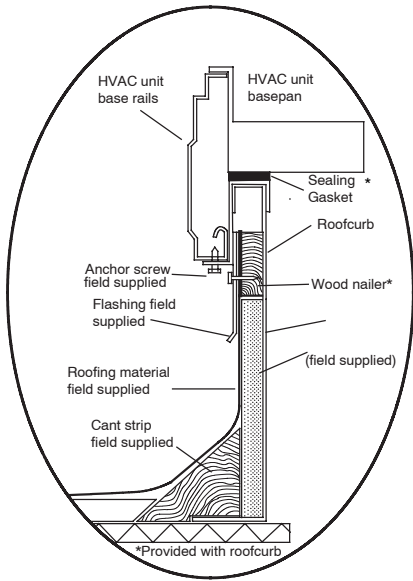
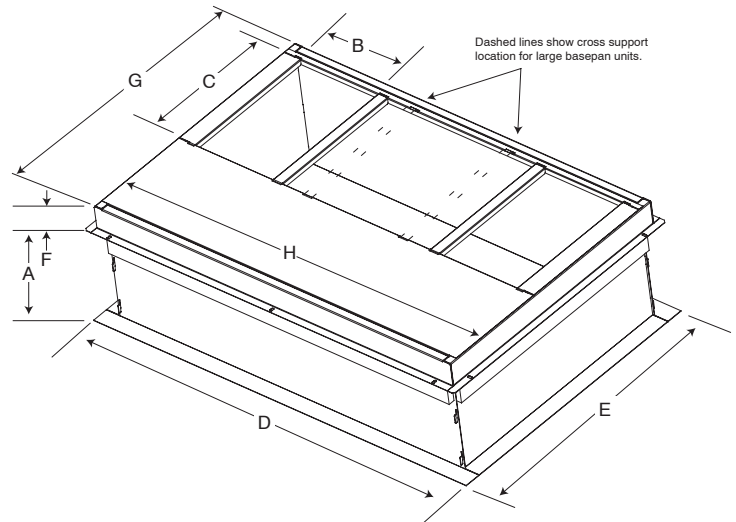

FIGURE 6

Roof Curb Dimensions



ROOF CURB DETAIL



SMALL/COMMON CURB

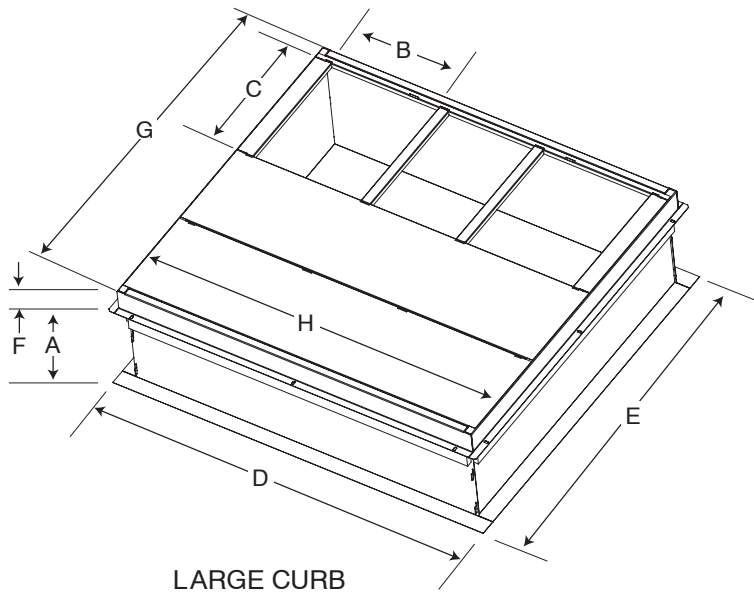

LARGE CURB

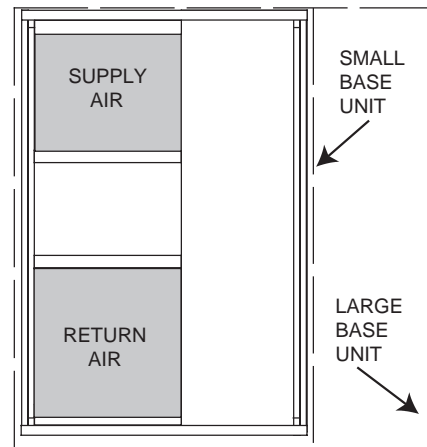

UNIT PLACEMENT ON COMMON CURB
SMALL OR LARGE BASE UNIT

| UNIT SIZE | CATALOG NUMBER | A IN. (mm) | B (small/common base) IN. (mm)* | B (large base) IN. (mm)* | C IN. (mm) | D IN. (mm) | E IN. (mm) | F IN. (mm) | G IN. (mm) | H IN. (mm) |
|----------------|----------------|---------------|---------------------------------------|--------------------------------|---------------|---------------|---------------|---------------|---------------|---------------|
| Small or Large | CPRFCURB010A00 | 11 (279) | 10 (254) | 14 (356) | 16 (406) | 47.8 (1214) | 32.4 (822) | 2.7 (69) | 30.6 (778) | 46.1 (1170) |
| | CPRFCURB011A00 | 14 (356) | | | | | | | | |
| Large | CPRFCURB012A00 | 11 (279) | 14 (356) | | | | | | | |
| | CPRFCURB013A00 | 14 (356) | | | | | | | | |

NOTES:

1. Roof curb must be set up for unit being installed.
2. Seal strip must be applied, as required, to unit being installed.
3. Roof curb is made of 16-gauge steel.
4. Attach ductwork to curb (flanges of duct rest on curb).
5. Insulated panels: 1-in. (25 mm) thick fiberglass 1 lb. density.

CONFIGURING UNITS FOR DOWNFLOW (VERTICAL) DISCHARGE

⚠ WARNING

ELECTRICAL SHOCK HAZARD

Failure to follow this warning could result in personal injury or death.

Before installing or servicing system, turn off the power supply to the unit and install lockout tag. There may be more than one disconnect switch.

1. Open all electrical disconnects and install lockout tag before starting any service work.
2. Remove horizontal (metal) ductcovers to access vertical (downflow) discharge duct knockouts in unit basepan. (See Fig. 7.)
3. To remove downflow return and supply knockout covers, break front and right side connecting tabs with a screwdriver and hammer. Push cover down to break rear and left side tabs.

NOTE: These panels are held in place with tabs similar to an electrical knockout. Reinstall horizontal duct covers (Fig. 7) shipped on unit from factory. Insure openings are air and watertight.

NOTE: The design and installation of the duct system must be in accordance with the standards of the NFPA for installation of nonresidence-type air conditioning and ventilating systems, NFPA 90A or residence-type, NFPA 90B; and/or local codes and ordinances.

Adhere to the following criteria when selecting, sizing, and installing the duct system:

1. Units are shipped for side shot installation.
2. Select and size ductwork, supply-air registers, and return-air grilles according to American Society of Heating, Refrigeration and Air Conditioning Engineers (ASHRAE) recommendations.
3. Use flexible transition between rigid ductwork and unit to prevent transmission of vibration. The transition may be screwed or bolted to duct flanges. Use suitable gaskets to ensure weather-tight and airtight seal.
4. All units must have field-supplied filters or accessory filter rack installed in the return-air side of the unit. Recommended sizes for filters are shown in Table 1.
5. Size all ductwork for maximum required airflow (either heating or cooling) for unit being installed. Avoid abrupt duct size increases or decreases or performance may be affected.
6. Adequately insulate and weatherproof all ductwork located outdoors. Insulate ducts passing through unconditioned space, and use vapor barrier in accordance with latest issue of Sheet Metal and Air Conditioning Contractors National Association (SMACNA) and Air Conditioning Contractors of America (ACCA) minimum installation standards for heating and air conditioning systems. Secure all ducts to building structure.
7. Flash, weatherproof, and vibration-isolate all openings in building structure in accordance with local codes and good building practices.

FIGURE 7 Supply and Return Duct Openings

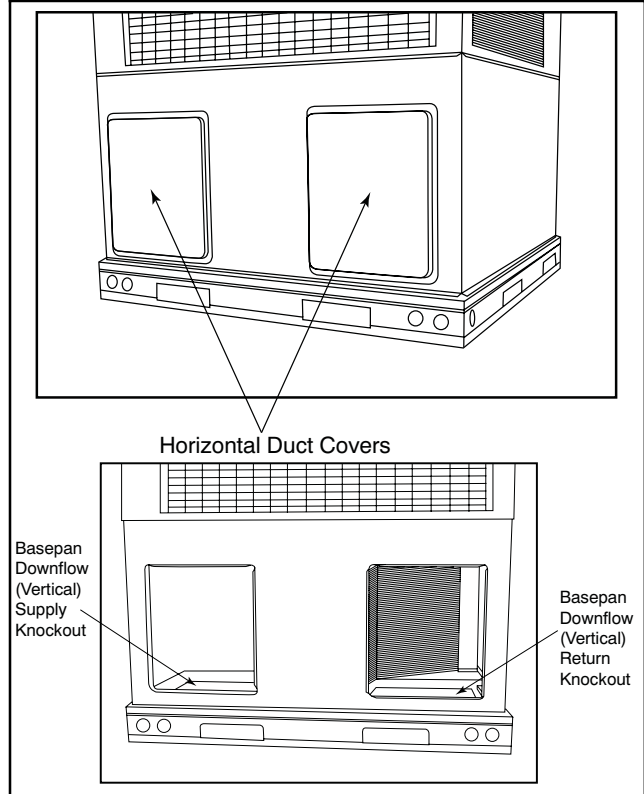

Provide for Condensate Disposal

NOTE: Ensure that condensate-water disposal methods comply with local codes, restrictions, and practices.

The PHD5 units dispose of condensate through a 3/4 in. NPT female fitting that exits on the compressor end of the unit. Condensate water can be drained directly onto the roof in rooftop installations (where permitted) or onto a gravel apron in ground level installations. Install a field-supplied condensate trap at end of condensate connection to ensure proper drainage. Make sure that the outlet of the trap is at least 1 in. (25 mm) lower than the drain-pan condensate connection to prevent the pan from overflowing. Prime the trap with water. When using a gravel apron, make sure it slopes away from the unit.

If the installation requires draining the condensate water away from the unit, install a field-supplied 2 -in. (51mm) trap at the condensate connection to ensure proper drainage. Condensate trap is available as an accessory or is field-supplied. Make sure that the outlet of the trap is at least 1 in. (25 mm) lower than the unit drain-pan condensate connection to prevent the pan from overflowing. Connect a drain tube using a minimum of field-supplied 3/4-in. PVC or field-supplied 3/4-in. copper pipe at outlet end of the 2-in. (51 mm) trap. (See Fig. 8) Do not undersize the tube. Pitch the drain tube downward at a slope of at least 1 in. (25 mm) every 10 ft (3 m) of horizontal run. Be sure to check the drain trough for leaks. Prime the trap at the beginning of the cooling season start-up.

FIGURE 8 Condensate Trap

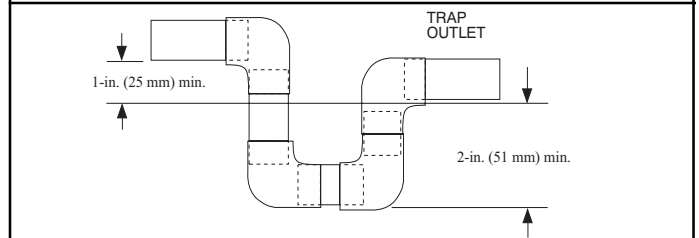
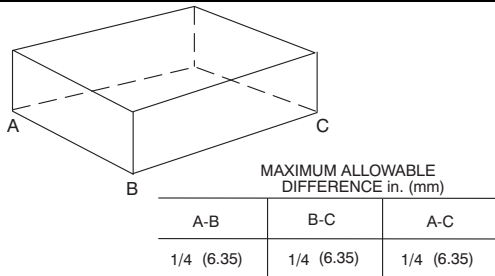

FIGURE 9 Unit Leveling Tolerances



Install Electrical Connections

⚠ WARNING

ELECTRICAL SHOCK HAZARD

Failure to follow this warning could result in personal injury or death.

The unit cabinet must have an uninterrupted, unbroken electrical ground. This ground may consist of an electrical wire connected to the unit ground screw in the control compartment, or conduit approved for electrical ground when installed in accordance with NEC, ANSI/NFPA American National Standards Institute/National Fire Protection Association (latest edition) (in Canada, Canadian Electrical Code CSA C22.1) and local electrical codes.

⚠ CAUTION

UNIT COMPONENT DAMAGE HAZARD

Failure to follow this caution may result in damage to the unit being installed.

1. Make all electrical connections in accordance with NEC ANSI/NFPA (latest edition) and local electrical codes governing such wiring. In Canada, all electrical connections must be in accordance with CSA standard C22.1 Canadian Electrical Code Part 1 and applicable local codes. Refer to unit wiring diagram.
2. Use only copper conductor for connections between field-supplied electrical disconnect switch and unit. **DO NOT USE ALUMINUM WIRE.**
3. Be sure that high-voltage power to unit is within operating voltage range indicated on unit rating plate.
4. Do not damage internal components when drilling through any panel to mount electrical hardware, conduit, etc.

HIGH-VOLTAGE CONNECTIONS

⚠ WARNING

ELECTRICAL SHOCK HAZARD

Failure to follow this warning could result in personal injury or death.

Before making any wiring changes, switch off the main power supply to the unit and install lockout tag.

The unit must have a separate electrical service with a field-supplied, waterproof disconnect switch mounted at, or within sight from the unit. Refer to the unit rating plate, NEC and local codes for maximum fuse/circuit breaker size and minimum circuit amps (ampacity) for wire sizing.

The field-supplied disconnect switch box may be mounted on the unit over the high-voltage inlet hole when the standard power and low-voltage entry points are used (See Fig. 4 and 5 for acceptable location). Remove the high voltage knockout.

See unit wiring label, Fig. 10 and Fig. 13-14, for reference when making high voltage connections. Proceed as follows to complete the high-voltage connections to the unit.

FIGURE 10 High and Control Voltage Connections

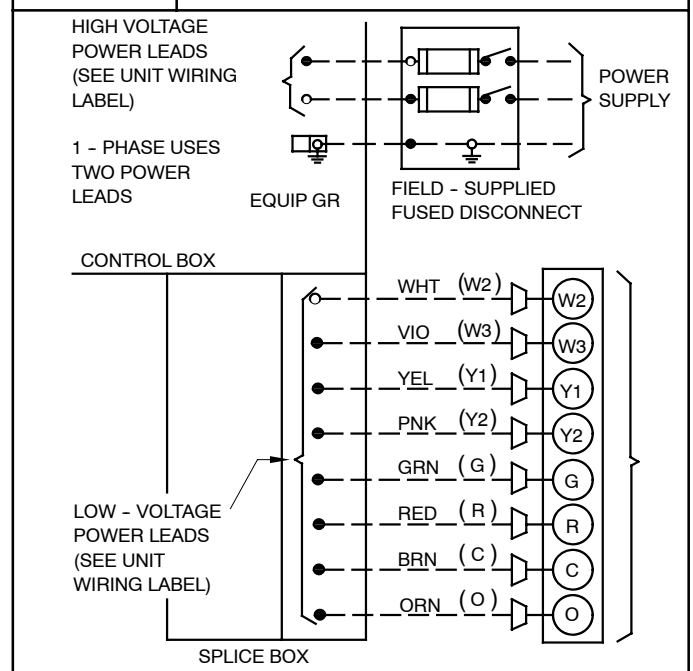

Single phase units:

1. Run the high-voltage (L1, L2) and ground lead into the control box.
2. Connect ground lead to chassis ground connection.
3. Locate the black and yellow wires connected to the line side of the contactor.
4. Connect field L1 to black wire on connection 11 of the compressor contactor.
5. Connect field wire L2 to yellow wire on connection 23 of the compressor contactor.

SPECIAL PROCEDURES FOR 208-V OPERATION

⚠ WARNING

ELECTRICAL SHOCK HAZARD

Failure to follow this warning could result in personal injury or death.

Before making any wiring changes, switch off the main power supply to the unit. Tag the disconnect switch with a suitable warning label. With disconnect switch open, move black wire from transformer (3/16 in.) terminal marked 230 to terminal marked 208. This retaps transformer to primary voltage of 208 vac.

CONTROL VOLTAGE CONNECTIONS

NOTE: Do not use any type of power-stealing thermostat. Unit control problems may result.

Use no. 18 American Wire Gage (AWG) color-coded, insulated (35°C minimum) wires to make the control voltage connections between the thermostat and the unit. If the thermostat is located more than 100 ft (30.5 m) from the unit (as measured along the control voltage wires), use no. 16 AWG color-coded, insulated (35°C minimum) wires.

STANDARD CONNECTIONS

Locate the eight low voltage thermostat leads in 24 volt splice box. See figure 13 for connection diagram. Run the low-voltage leads from the thermostat, through the control wiring inlet hole grommet, (fig. 4 and 5), and into the low-voltage splice box. Provide a drip loop before running wires through panel. Secure and strain relief all wires so that they do not interfere with operation of unit.

If an accessory electric heater is installed, low voltage leads from heater must be connected to factory supplied control leads from Indoor Fan Board P4 connector. Factory wires are provided for electric heat staging W2 and W3 (Please note that some thermostats are marked "W1" and "W2" for first and second stage electric heat, respectively). If room thermostat has only one stage of supplemental heat, connect white and violet wires shown in figure 10 to second stage heat field wire.

Some electric heaters have four control wires (plus common wire). Consult unit wiring diagram and electric heater wiring diagram for additional details.

TRANSFORMER PROTECTIONS

The transformer is of the energy-limiting type. It is set to withstand a 30-second overload or shorted secondary condition. If an overload or short is present, correct overload condition and check for blower fuse on control board. Replace fuse as required with correct size and rating.

ACCESSORY ELECTRIC HEATER

Electric heaters may be installed with the PHD5 units per instructions supplied with electric heater package. See unit rating plate for factory-approved electric heater kits.

SEQUENCE OF OPERATION

- a. CONTINUOUS FAN
 - (1.) Thermostat closes circuit R to G energizing the blower motor for continuous fan. The indoor fan is energized on low speed.
- b. COOLING MODE
 - (1.) Low Stage: Thermostat closes R to G, R to Y1 and R to O. The compressor and indoor fan are energized on low speed. The outdoor fan and reversing valve are energized.
 - (2.) High Stage: Thermostat closes R to G, R to Y1, R to Y2, and R to O. The compressor and indoor fan are energized on high speed. The outdoor fan and reversing valve are energized.
- c. ELECTRIC HEATING MODE
 - (1.) Thermostat closes circuit R to W2 or W3, and R to G. There are no on or off delays.
- d. HEAT PUMP HEATING MODE
 - (1.) Low Stage: Thermostat closes circuits R to G and R to Y1. The compressor and indoor fan are energized on low speed. The outdoor fan is also energized.
 - (2.) High Stage: Thermostat closes R to G, R to Y1, and R to Y2. The compressor and indoor fan are energized on high speed. The outdoor fan is also energized.
- e. HEAT PUMP HEATING WITH AUXILIARY ELECTRIC HEAT
 - (1.) Thermostat closes circuits R to G, R to Y2 and R to W2 or W3. The compressor and indoor fan are energized on high speed. The outdoor fan and electric heat relays are also energized.
- f. DEFROST MODE

The defrost mode is automatically energized by the defrost board during heating mode. The defrost board energizes "O" (reversing valve) and "W2" (electric heat). It also de-energizes the outdoor fan. When defrost is complete, unit will return to heating mode. If room thermostat is satisfied during defrost, unit will shut down and restart in defrost on next call for heat.

Table 1—Physical Data - Unit PHD5

| UNIT SIZE | PHD524 | PHD536 | PHD548 | PHD560 |
|---|---|--|---|---|
| NOMINAL CAPACITY (ton) | 2 | 3 | 4 | 5 |
| SHIPPING WEIGHT lb (kg) | 435 (197) | 501 (227) | 529 (240) | 572 (259) |
| COMPRESSOR TYPE | TWO STAGE SCROLL COMPRESSOR | | | |
| Refrigerant (R-410A) Quantity lb Quantity (kg) | 10.3 (4.67) | 9.7 (3.99) | 15.5 (7.03) | 16.0 (7.3) |
| EXPANSION DEVICE - HEATING | FIXED ORIFICE | | | |
| ORIFICE OD (in.) - Left | 0.042 | 0.035 | 0.038 | 0.046 |
| ORIFICE OD (in.) - Right | N/A | 0.035 | 0.046 | 0.046 |
| EXPANSION DEVICE - COOLING | TXV | | | |
| SIZE | 2 TON | 3 TON | 4 TON | 5 TON |
| PART NUMBER | EA36YD129 | EA36YD139 | EA36YD149 | EA36YD159 |
| OUTDOOR COIL Rows... Fins/in. face area (sq. ft.) | 2...21 13.6 | 2...21 17.5 | 2...21 19.4 | 2...21 23.3 |
| OUTDOOR FAN Nominal Airflow (CFM) Diameter Motor HP (RPM) | 2700 22 1/8 (825) | 2800 22 1/8 (825) | 3300 22 1/4 (1100) | 3300 22 1/3 (1110) |
| INDOOR COIL Rows... Fins/in. face area (sq. ft.) | 3...17 3.7 | 3...17 4.7 | 3...17 5.7 | 4...17 5.7 |
| INDOOR BLOWER Nominal Low Stage Airflow (CFM) Nominal High Stage Airflow (CFM) Blower Wheel Size in. x in. (mm) (mm x mm) Motor (HP) | 600 800 10x10 (254x254) 1/2 | 850 1200 11x10 (279x254) 3/4 | 1100 1600 11x10 (279x254) 1.0 | 1200 1750 11x10 (279x254) 1.0 |
| HIGH-PRESSURE SWITCH (psig) Cutout Reset (Auto) | 670±15 470±25 | | | |
| LOSS-OF-CHARGE/LOW-PRESSURE SWITCH (Liquid Line) (psig) Cutout Reset (Auto) | 23±5 55±5 | | | |
| RETURN-AIR FILTERS* Throwaway in. (mm) | 20x24x1 (508x610x25) | 24x30x1 (610x762x25) | 24x36x1 (610x914x25) | |

* Recommended filter sizes for field-installed air filter grilles mounted on the wall or ceiling of the conditioned structure. Required filter sizes shown are based on the ARI (Air conditioning and Refrigeration Institute) rated high stage cooling airflow and a maximum face velocity of 300 ft/minute for throwaway type or 450 ft/minute for permanent filters. Air filter pressure drop for non-standard filters must not exceed 0.08 IN. W.C.

Table 2—Minimum Airflow for Reliable Electric Heater Operation (CFM)

| SIZE | PHD524 | PHD536 | PHD548 | PHD560 |
|---------------|--------|--------|--------|--------|
| AIRFLOW (CFM) | 800 | 1250 | 1710 | 1800 |

FIGURE 11 Typical Installation

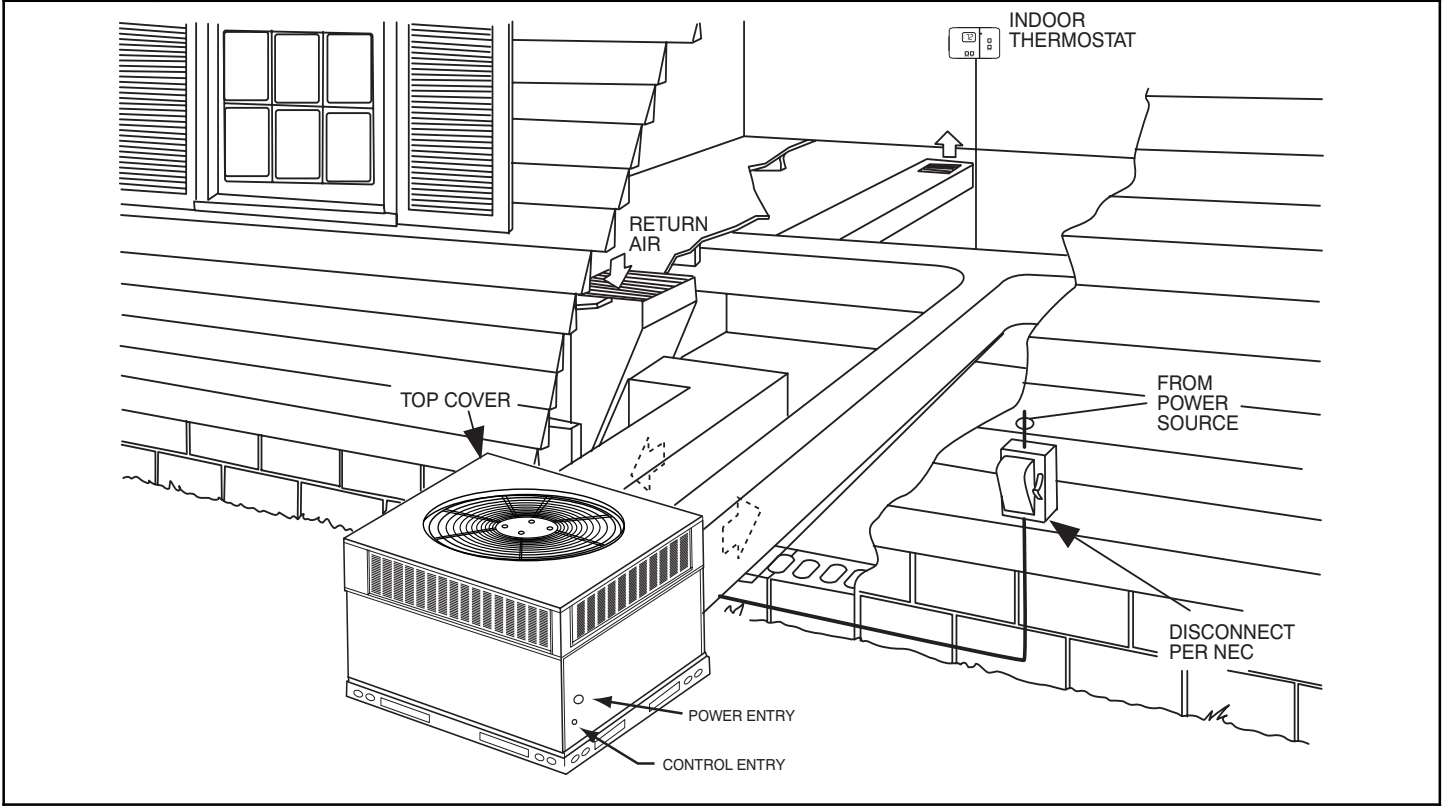

FIGURE 12 Unit Access Panels

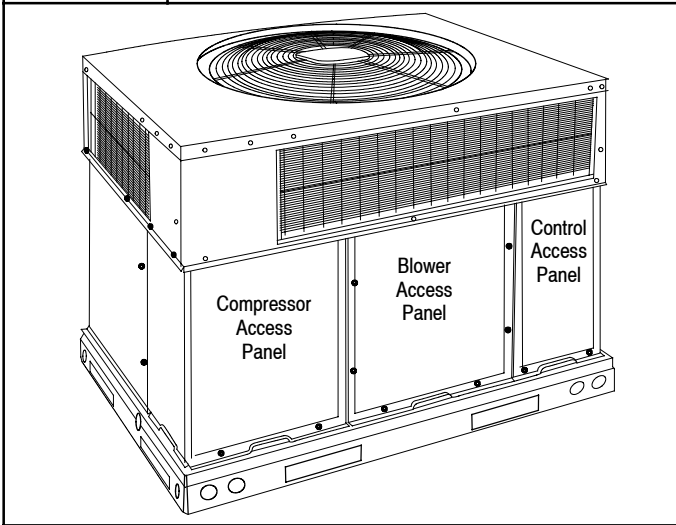

FIGURE 13

PHD524-60 (208/230-1-60) Connection Wiring Diagram

DANGER: ELECTRICAL SHOCK HAZARD DISCONNECT POWER BEFORE SERVICING

SCHEMATIC
208/230-1-60

FIELD SUPPLY POWER
UNIT ONLY
MAXIMUM WIRE
SIZE 2 AWG.
EQUIP_GND

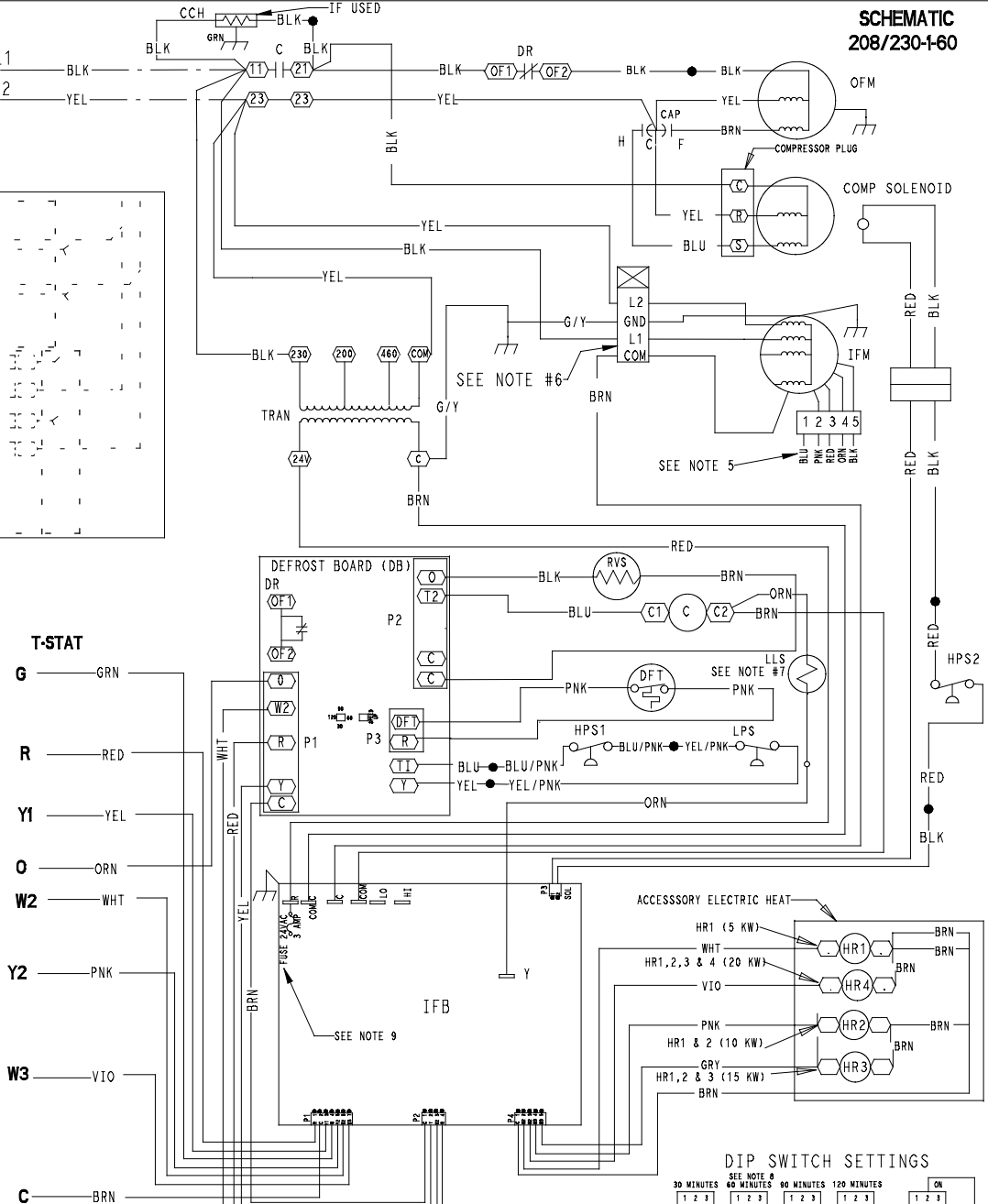
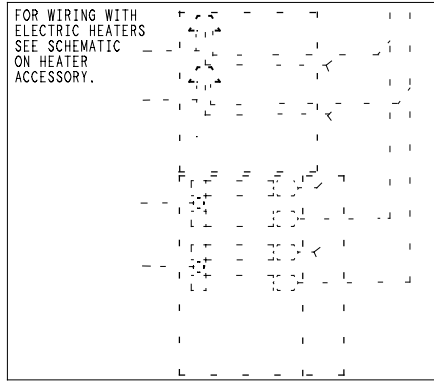

UNIT COMPONENT ARRANGEMENT

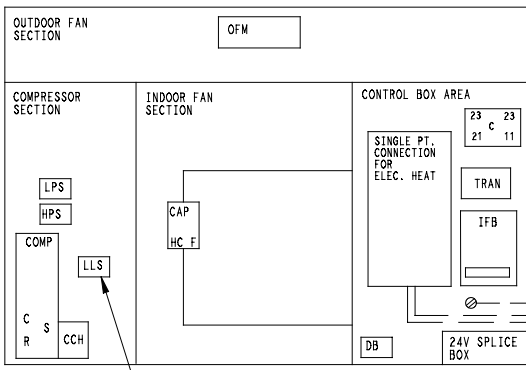

LEGEND

- △ FIELD SPlice
- TERMINAL (MARKED)
- TERMINAL (UNMARKED)
- SPlice
- SPlice (MARKED)
- FACTORY WIRING
- FIELD CONTROL WIRING
- FIELD POWER WIRING
- ACCESSORY OR OPTIONAL WIRING
- TO INDICATE COMMON POTENTIAL ONLY; NOT TO REPRESENT WIRING
- C CONTACTOR
- CAP CAPACITOR
- CB CIRCUIT BREAKER
- CCH CRANK CASE HEATER
- COMP COMPRESSOR MOTOR
- CTD COMPRESSOR TIME DELAY
- DB DEFROST BOARD
- DFT DEFROST THERMOSTAT
- DR DEFROST RELAY
- FCB FAN CONTROL BOARD
- GND GROUND
- HR HEATER RELAY
- IFB INDOOR FAN BOARD
- IFM INDOOR FAN MOTOR
- IFM INDOOR FAN MOTOR
- LLS LIQUID LINE SOLENOID
- LPS LOW PRESSURE SWITCH
- OFM OUTDOOR FAN MOTOR
- RVS REVERSING VALVE SOLENOID
- TRAN TRANSFORMER
- T-STAT THERMOSTAT

NOTES:

1. IF ANY OF THE ORIGINAL WIRES FURNISHED ARE REPLACED, IT MUST BE REPLACED WITH TYPE 90 DEGREE C WIRE OR IT'S EQUIVALENT.
2. SEE PRICE PAGES FOR THERMOSTAT AND SUBBASES.
3. USE 75 DEGREE COPPER CONDUCTORS FOR FIELD INSTALLATION.
4. DEFROST TIMER TO BE SET AT 60 MIN.
5. SEE INSTALLATION INSTRUCTIONS FOR PROPER HEATING AND COOLING CONNECTIONS FOR YOUR UNIT. INDOOR FAN PLUGS -DO NOT DISCONNECT UNDER LOAD.
6. "DO NOT DISCONNECT PLUG UNDER LOAD."
7. USED ON 924 AND 980 UNITS ONLY.
8. SEE INSTALLATION INSTRUCTIONS FOR FACTORY SETTINGS.
9. THIS FUSE IS MANUFACTURED BY LITTLEFUSE, P/N 257003.

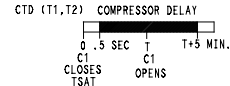
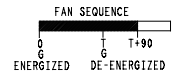
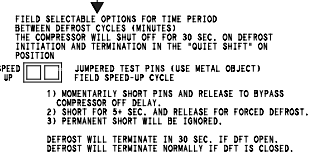
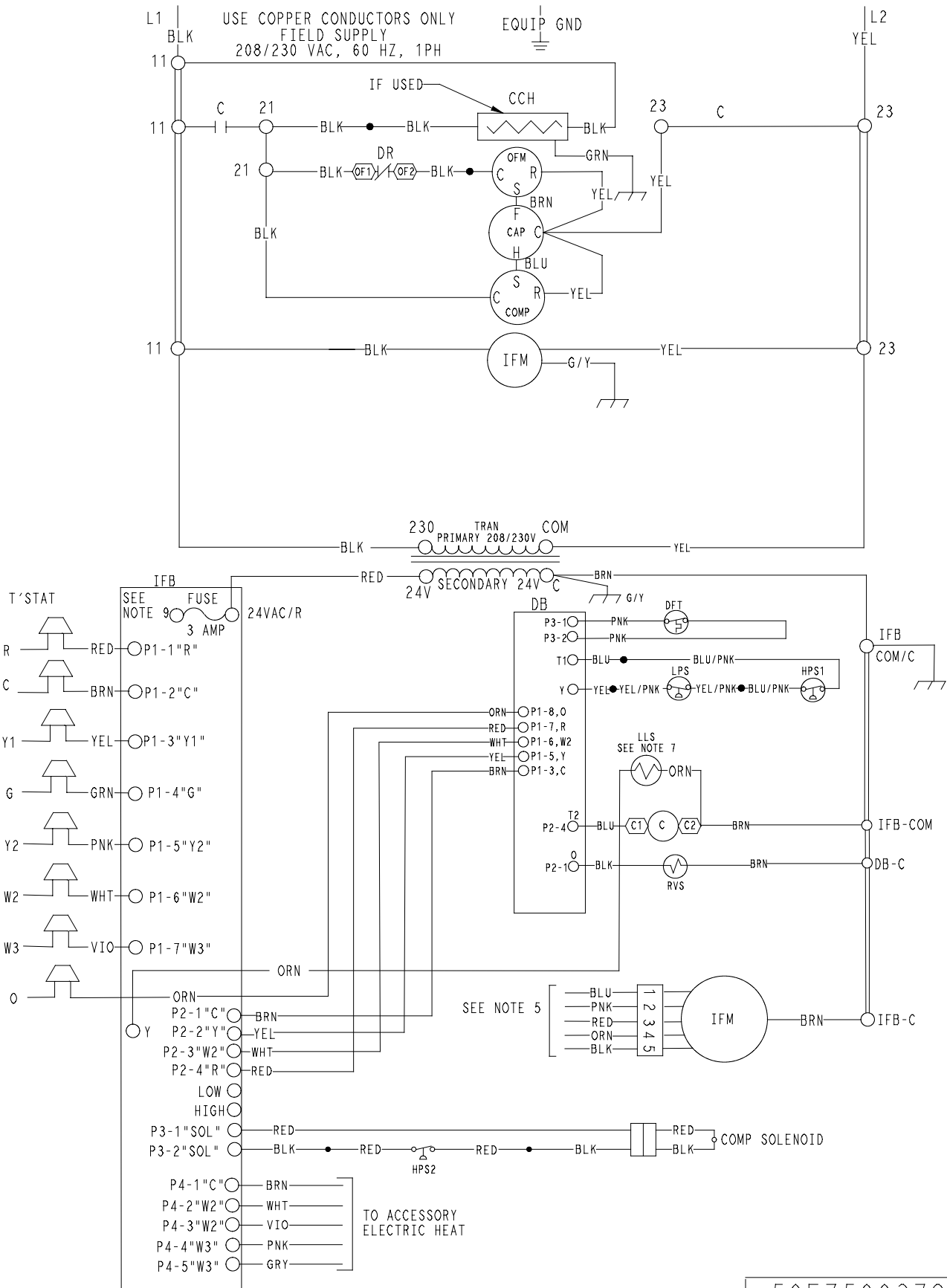

FIGURE 14

PHD524-60 (208/230-1-60) Ladder Wiring Diagram

DANGER: ELECTRICAL SHOCK HAZARD DISCONNECT POWER BEFORE SERVICING



50EZ500378 | C

PRE-START-UP



WARNING

FIRE, EXPLOSION, ELECTRICAL SHOCK HAZARD

Failure to follow this warning could result in personal injury or death.

1. Follow recognized safety practices and wear protective goggles when checking or servicing refrigerant system.
2. Relieve and recover all refrigerant from system before touching or disturbing compressor plug if refrigerant leak is suspected around compressor terminals.
3. Do not remove compressor plug until all electrical sources are disconnected and tagged.
4. Never attempt to repair soldered connection while refrigerant system is under pressure.
5. Do not use torch to remove any component. System contains oil and refrigerant under pressure. To remove a component, wear protective goggles and proceed as follows:
 - a. Shut off electrical power to unit and install lockout tag.
 - b. Relieve and reclaim all refrigerant from system using both high- and low-pressure ports.
 - c. Cut component connecting tubing with tubing cutter and remove component from unit.
 - d. Carefully unsweat remaining tubing stubs when necessary. Oil can ignite when exposed to torch flame.

Use the Start-Up Checklist supplied at the end of this book and proceed as follows to inspect and prepare the unit for initial start-up:

1. Remove access panels. See Fig. 12.
2. Read and follow instructions on all DANGER, WARNING, CAUTION, and INFORMATION labels attached to, or shipped with unit.
3. Make the following inspections:
 - a. Inspect for shipping and handling damage, such as broken lines, loose parts, disconnected wires, etc.
 - b. Inspect for oil at all refrigerant tubing connections and on unit base. Detecting oil generally indicates a refrigerant leak. Leak-test all refrigerant tubing connections using electronic leak detector, or liquid-soap solution. If a refrigerant leak is detected, see following Check for Refrigerant Leaks section.
 - c. Inspect all field- and factory-wiring connections. Be sure that connections are completed and tight. Ensure wires do not touch refrigerant tubing or sharp sheet metal edges.
 - d. Inspect coil fins. If damaged during shipping and handling, carefully straighten fins with a fin comb.
4. Verify the following conditions:
 - a. Make sure that outdoor-fan blade is correctly positioned in fan orifice.
 - b. Make sure that air filter(s) is in place.
 - c. Make sure that condensate drain pan and trap are filled with water to ensure proper drainage.
 - d. Make sure that all tools and miscellaneous loose parts have been removed.
5. Each unit system has two (2) Schrader-type ports, one low-side Schrader fitting located on the suction line, and one

high-side Schrader fitting located on the compressor discharge line. Be sure that caps on the ports are tight.

START-UP

CHECK COOLING AND HEATING OPERATION

Start and check the unit for proper control operation as follows:

- (1.) Place room thermostat SYSTEM switch or MODE control in OFF position. Observe that blower motor starts when FAN mode is placed in FAN ON position and shuts down when FAN MODE switch is placed in AUTO position.
- (2.) Thermostat:

On a typical two stage thermostat, when the room temperature rises 1 or 2 degrees above the cooling control setting of the thermostat, the thermostat completes the circuit between thermostat terminal R and terminals Y1, O, and G. These completed circuits through the thermostat connect the contactor coil (C) (through unit wire Y1) and indoor fan board (through unit wire G) across the 24-v. secondary of transformer (TRAN).

On a typical two stage thermostat, when the room temperature is several degrees above the cooling control setting of the thermostat, the thermostat completes the circuit between terminal R and terminals Y1, Y2, O, and G.
- (3.) Place system switch or MODE control in HEAT position. Set control above room temperature. Observe that compressor, outdoor fan, and indoor blower motors start. Observe that heating cycle shuts down when control setting is satisfied.
- (4.) When using an automatic changeover room thermostat place both SYSTEM or MODE control and FAN mode switches in AUTO positions. Observe that unit operates in Cooling mode when temperature control is set to "call for Cooling" (below room temperature), and unit operates in Heating mode when temperature control is set to "call for Heating" (above room temperature).

NOTE: Once the compressor has started and then has stopped, it should not be started again until 5 minutes have elapsed. The defrost board has a built-in 5 minute delay between cycles. The 5 minute compressor delay also applies to heat pump heating mode.

CHECK FOR REFRIGERANT LEAKS

Proceed as follows to locate and repair a refrigerant leak and to charge the unit:

1. Locate leak and make sure that refrigerant system pressure has been relieved and reclaimed from both high- and low-pressure ports.
2. Repair leak following Refrigerant Service procedures.

NOTE: Install a bi-flow filter drier whenever the system has been opened for repair.

3. Add a small charge of R-410A refrigerant vapor to system and leak-test unit.
4. Recover refrigerant from refrigerant system and evacuate to 500 microns if no additional leaks are found.
5. Charge unit with R-410A refrigerant, using an electronic scale. Refer to unit rating plate for required charge.

START-UP ADJUSTMENTS

Complete the required procedures given in the Pre-Start-Up section before starting the unit. Do not jumper any safety devices when operating the unit. Do not operate the unit in cooling mode when the outdoor temperature is below 40°F (4°C) (unless accessory low-ambient kit is installed).

Checking and Adjusting Refrigerant Charge

The refrigerant system is fully charged with R-410A refrigerant and is tested and factory sealed.

NOTE: Adjustment of the refrigerant charge is not required unless the unit is suspected of not having the proper R-410A charge.

A subcooling charging chart is attached to the inside of the compressor access panel, see fig. 12 and 18. The chart includes the required liquid line temperature at given discharge line pressures and outdoor ambient temperatures.

An accurate thermocouple- or thermistor-type thermometer, and a gauge manifold are required when using the subcooling charging method for evaluating the unit charge. Do not use mercury or small dial-type thermometers because they are not adequate for this type of measurement.

NOTE: Allow system to operate on high stage cooling for a minimum of 15 minutes before checking or adjusting refrigerant charge.

IMPORTANT: When evaluating the refrigerant charge, an indicated adjustment to the specified factory charge must always be very minimal. If a substantial adjustment is indicated, an abnormal condition exists somewhere in the cooling system, such as insufficient airflow across either coil or both coils.

1. Remove caps from low- and high-pressure service fittings.
2. Using hoses with valve core depressors, attach low- and high-pressure gauge hoses to low- and high-pressure service fittings, respectively.
3. Start unit and let run until system pressures stabilize.
4. Measure and record the following:
 - a. Outdoor ambient-air temperature (°F [°C] db).
 - b. Liquid line temperature (°F [°C]) at TXV.
 - c. Discharge (high-side) pressure (psig).
 - d. Suction (low-side) pressure (psig) (for reference only).
5. Using Cooling Charging Charts compare outdoor-air temperature (°F [°C] db) with the discharge line pressure (psig) to determine desired system operating liquid line temperature (See Fig. 19).
6. Compare actual liquid line temperature with desired liquid line temperature. Using a tolerance of $\pm 2^{\circ}\text{F}$ ($\pm 1.1^{\circ}\text{C}$), add refrigerant if actual temperature is more than 2°F (1.1°C) higher than proper liquid line temperature, or remove refrigerant if actual temperature is more than 2°F (1.1°C) lower than required liquid line temperature.

NOTE: If the problem causing the inaccurate readings is a refrigerant leak, refer to Check for Refrigerant Leaks section.

Indoor Airflow and Airflow Adjustments

⚠ CAUTION

UNIT OPERATION HAZARD

Failure to follow this caution may result in unit damage.

For cooling operation, the recommended airflow is 350 to 450 cfm for each 12,000 Btuh of rated cooling capacity. For heating operation, the airflow must produce a temperature rise that falls within the range stamped on the unit rating plate.

All blower motors are factory wired for nominal high stage and low stage cooling airflow operation at minimum external static pressure. See Table 1.

NOTE: Be sure that all supply- and return-air grilles are open, free from obstructions, and adjusted properly.

Table 3—Color Coding for Indoor Fan Motor Leads

| |
|-------------------------|
| Black = High Speed |
| Orange = Med-High Speed |
| Red = Med Speed |
| Pink = Med-Low Speed |
| Blue = Low Speed |

⚠ WARNING

ELECTRICAL SHOCK HAZARD

Failure to follow this warning could result in personal injury or death.

Disconnect electrical power to the unit and install lockout tag before changing blower speed.

The high stage cooling fan speed of the unit is connected to the "HIGH" terminal on the interface fan board (IFB) (See Fig. 16). The low stage cooling fan speed of the unit is connected to the "LOW" terminal on the interface fan board (IFB) (See Fig. 16). The unit is factory-shipped with fan speeds as noted in Table 4. There are 3 additional speed tap wires available for use (For color coding on the indoor fan motor leads, see Table 3). The additional 3 speed tap wires are shipped loose with vinyl caps and are located in the control box, near the IFB.

To change the fan speed, remove the vinyl cap off of the desired speed tap wire (Refer to Table 3 for color coding). Remove the current speed tap wire from the "HIGH" or "LOW" terminal on the interface fan board (IFB) (Fig. 16) and place vinyl cap over the connector on the wire. Connect the desired speed tap wire to the "HIGH" or "LOW" terminal on the IFB. For optimum performance, add the wet coil pressure drop in Table 5 to the system static to determine the correct cooling airflow speed in Table 4 that will deliver the nominal cooling airflow as listed in Table 1 for each size.

NOTE: For cooling operation, the recommended airflow is 350 to 450 CFM for each 12,000 Btuh of rated cooling capacity.

NOTE: If accessory electric heat is installed in the unit, the dry airflow must meet or exceed the minimum airflow specified in Table 2 for the specific size. Use Table 4 to determine dry airflow for a known external static pressure. Electric heat fan speed is the same as high stage cooling fan speed.

Continuous Fan Operation

The continuous fan operates at the same fan speed as low stage cooling fan operation.

FIGURE 15

Typical Heat Pump Operation - Cooling Mode

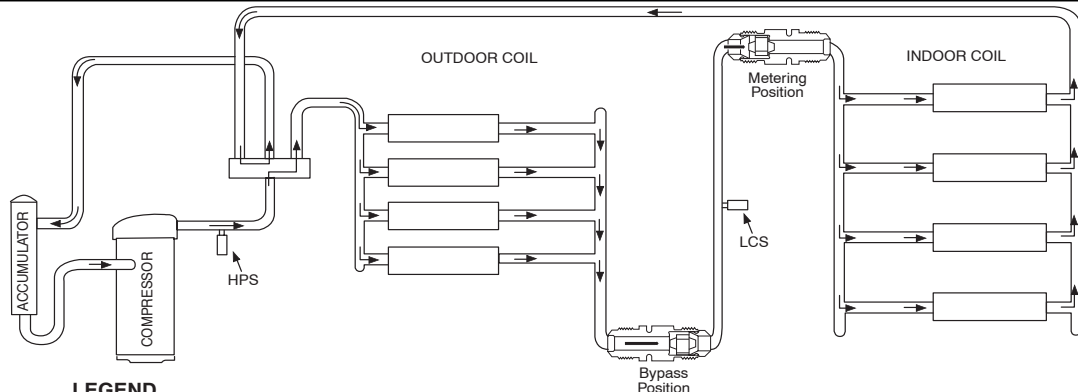

LEGEND



- HPS – High Pressure Switch
- LCS – Loss of Charge Switch
-  Piston Metering Device
-  Arrow indicates direction of flow

FIGURE 16

Interface Fan Board

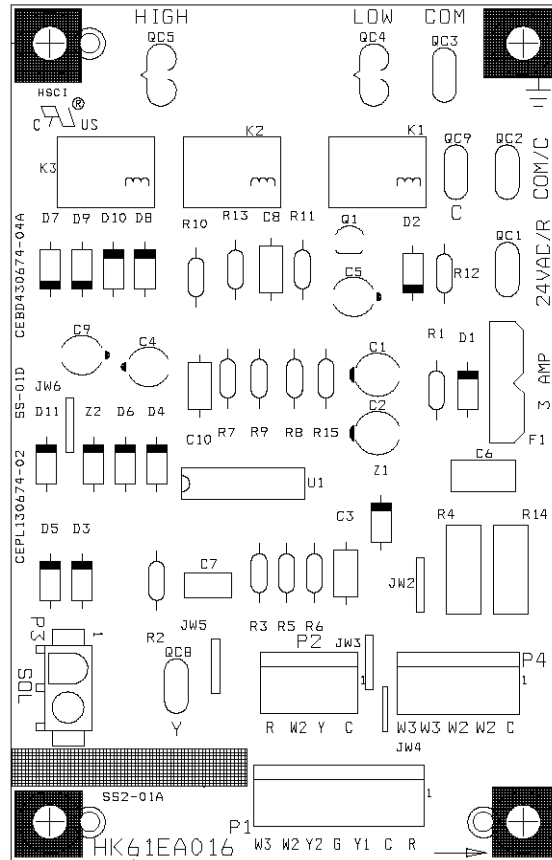
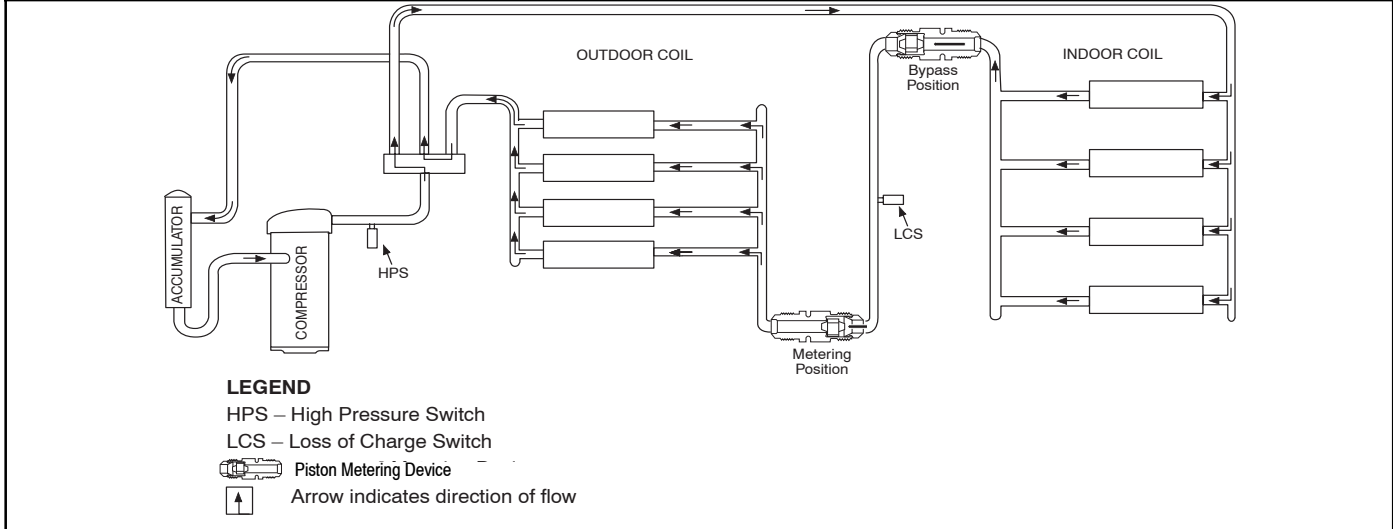

FIGURE 17

Typical Heat Pump Operation - Heating Mode



Defrost Control

Quiet Shift

Quiet Shift is a field-selectable defrost mode, which will eliminate occasional noise that could be heard at the start of defrost cycle and restarting of heating cycle. It is selected by placing DIP switch 3 (on defrost board) in ON position. See Fig. 18.

When Quiet Shift switch is placed in ON position, and a defrost is initiated, the following sequence of operation will occur. Reversing valve will energize, outdoor fan will turn off, compressor will turn off for 30 sec and then turn back on to complete defrost. At the start of heating after conclusion of defrost reversing valve will de-energize, compressor will turn off for another 30 sec, and the outdoor fan will stay off for 40 sec, before starting in the Heating mode.

Defrost

The defrost control is a time/temperature control which includes a field-selectable time period (DIP switch 1 and 2 on the board) between defrost cycles of 30, 60, 90, or 120 minutes. Factory settings are show below. To initiate a forced defrost, two options are available depending on the status of the defrost thermostat.

| Factory-Set Defrost Times | | | |
|---------------------------|--------|--------|--------|
| 2 Ton | 3 Ton | 4 Ton | 5 Ton |
| 120 min | 90 min | 60 min | 90 min |

If defrost thermostat is closed, speed-up pins (J1) must be shorted by placing a flat head screw driver in between for 5 sec and releasing, to observe a complete defrost cycle. When the Quiet Shift switch is selected, compressor will be turned off for two 30 sec intervals during this complete defrost cycle, as explained previously. When Quiet Shift switch is in factory default OFF position, a normal and complete defrost cycle will be observed.

If defrost thermostat is in open position, and speedup pins are shorted (with a flat head screw driver) for 5 sec and released, a short defrost cycle will be observed (actual length is dependent upon the selected Quiet Shift position). When Quiet Shift switch is in ON position, the length of defrost is 1 minute (30 sec compressor off period followed by 30 sec of defrost with compressor operation). On return to heating operation, compressor will again turn off for an additional 30 sec and the outdoor fan for 40 sec. When the Quiet Shift is in OFF position, only a brief 30 sec. cycle will be observed.

NOTE:Unit will remain in defrost until defrost thermostat reopens at approximately 65°F (18°C) coil temperature at liquid line or remainder of defrost cycle time.

FIGURE 18

Defrost Control

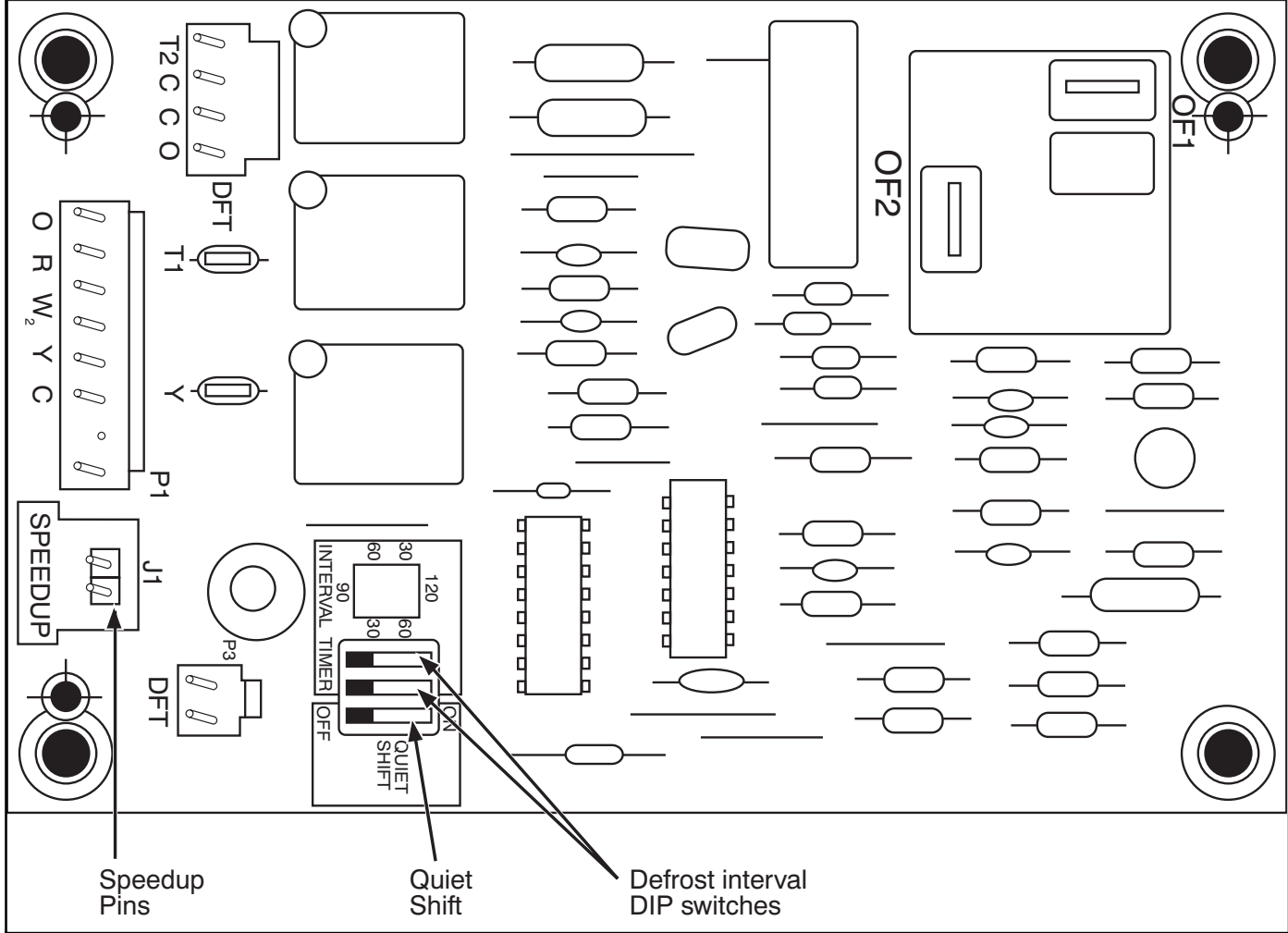

MAINTENANCE

To ensure continuing high performance, and to minimize the possibility of premature equipment failure, periodic maintenance must be performed on this equipment. This heat pump unit should be inspected at least once each year by a qualified service person. To troubleshoot unit, refer to Table 8.

NOTE: TO EQUIPMENT OWNER: Consult your local dealer about the availability of a maintenance contract.

⚠ WARNING

PERSONAL INJURY AND UNIT DAMAGE HAZARD

Failure to follow this warning could result in personal injury or death and unit component damage.

The ability to properly perform maintenance on this equipment requires certain expertise, mechanical skills, tools and equipment. If you do not possess these, do not attempt to perform any maintenance on this equipment, other than those procedures recommended in the Owner's Manual.

⚠ WARNING

ELECTRICAL SHOCK HAZARD

Failure to follow these warnings could result in personal injury or death:

1. Turn off electrical power to the unit and install a lockout tag before performing any maintenance or service on this unit.
2. Use extreme caution when removing panels and parts.
3. Never place anything combustible either on or in contact with the unit.

⚠ CAUTION

UNIT OPERATION HAZARD

Failure to follow this caution may result in improper operation.

Errors made when reconnecting wires may cause improper and dangerous operation. Label all wires prior to disconnecting when servicing.

The minimum maintenance requirements for this equipment are as follows:

1. Inspect air filter(s) each month. Clean or replace when necessary.
2. Inspect indoor coil, drain pan, and condensate drain each cooling season for cleanliness. Clean when necessary.
3. Inspect blower motor and wheel for cleanliness each cooling season. Clean when necessary.
4. Check electrical connections for tightness and controls for proper operation each cooling season. Service when necessary.

Air Filter

IMPORTANT: Never operate the unit without a suitable air filter in the return-air duct system. Always replace the filter with the same dimensional size and type as originally installed. See Table 1 for recommended filter sizes.

Inspect air filter(s) at least once each month and replace (throwaway-type) or clean (cleanable-type) at least twice during each cooling season and twice during the heating season, or whenever the filter becomes clogged with dust and lint.

Indoor Blower and Motor

NOTE: All motors are pre-lubricated. Do not attempt to lubricate these motors.

For longer life, operating economy, and continuing efficiency, clean accumulated dirt and grease from the blower wheel and motor annually.

⚠ WARNING

ELECTRICAL SHOCK HAZARD

Failure to follow this warning could result in personal injury or death.

Disconnect and tag electrical power to the unit before cleaning the blower motor and wheel.

To clean the blower motor and wheel:

1. Remove and disassemble blower assembly as follows:
 - a. Remove blower access panel. See Fig. 12.
 - b. Disconnect 5 pin plug and 4 pin plug from indoor blower motor.
 - c. On all units remove blower assembly from unit. Remove screws securing blower to blower partition and slide assembly out. Be careful not to tear insulation in blower compartment.
 - d. Ensure proper reassembly by marking blower wheel and motor in relation to blower housing before disassembly.
 - e. Loosen setscrew(s) that secures wheel to motor shaft, remove screws that secure motor mount brackets to housing, and slide motor and motor mount out of housing.
2. Remove and clean blower wheel as follows:
 - a. Ensure proper reassembly by marking wheel orientation.
 - b. Lift wheel from housing. When handling and/or cleaning blower wheel, be sure not to disturb balance weights (clips) on blower wheel vanes.
 - c. Remove caked-on dirt from wheel and housing with a brush. Remove lint and/or dirt accumulations from wheel and housing with vacuum cleaner, using soft brush attachment. Remove grease and oil with mild solvent.
 - d. Reassemble wheel into housing.
 - e. Reassemble motor into housing. Be sure setscrews are tightened on motor shaft flats and not on round part of shaft.

f. Connect 5 pin plug and 4 pin plug to indoor blower motor.

g. Reinstall blower access panel.

3. Restore electrical power to unit. Start unit and check for proper blower rotation and motor speeds during cooling cycles.

Outdoor Coil, Indoor Coil, and Condensate Drain Pan

Inspect the condenser coil, evaporator coil, and condensate drain pan at least once each year.

The coils are easily cleaned when dry; therefore, inspect and clean the coils either before or after each cooling season. Remove all obstructions, including weeds and shrubs, that interfere with the airflow through the condenser coil.

Straighten bent fins with a fin comb. If coated with dirt or lint, clean the coils with a vacuum cleaner, using the soft brush attachment. Be careful not to bend the fins. If coated with oil or grease, clean the coils with a mild detergent-and-water solution. Rinse coils with clear water, using a garden hose. Be careful not to splash water on motors, insulation, wiring, or air filter(s). For best results, spray condenser coil fins from inside to outside the unit. On units with an outer and inner condenser coil, be sure to clean between the coils. Be sure to flush all dirt and debris from the unit base.

Inspect the drain pan and condensate drain line when inspecting the coils. Clean the drain pan and condensate drain by removing all foreign matter from the pan. Flush the pan and drain trough with clear water. Do not splash water on the insulation, motor, wiring, or air filter(s). If the drain trough is restricted, clear it with a plumbers snake or similar probe device.

Outdoor Fan

Keep the condenser fan free from all obstructions to ensure proper cooling operation. Never place articles on top of the unit. Damage to unit may result.

1. Remove 6 screws holding outdoor grille and motor to top cover.
2. Turn motor/grille assembly upside down on top cover to expose fan blade.
3. Inspect the fan blades for cracks or bends.
4. If fan needs to be removed, loosen setscrew and slide fan off motor shaft.
5. When replacing fan blade, position blade back to same position as before.
6. Ensure that setscrew engages the flat area on the motor shaft when tightening.
7. Replace grille.

Table 4—Dry Coil Air Delivery* - Horizontal and Downflow Discharge - Unit PHD5

| Unit (Voltage) | Motor Speed | Wire Color | | External Static Pressure (IN. W.C.) | | | | | | | | |
|--------------------------|-----------------------|---------------|-----|-------------------------------------|------|------|------|------|------|------|------|------|
| | | | | 0.1 | 0.2 | 0.3 | 0.4 | 0.5 | 0.6 | 0.7 | 0.8 | 0.9 |
| PHD524 (208/230-1-60) | Low ¹ | Blue | CFM | 659 | 551 | 440 | 335 | --- | --- | --- | --- | --- |
| | Med-Low | Pink | CFM | 726 | 625 | 537 | 407 | --- | --- | --- | --- | --- |
| | Medium ² | Red | CFM | 907 | 837 | 759 | 679 | 588 | 474 | 343 | --- | --- |
| | Med-High | Orange | CFM | 953 | 870 | 807 | 718 | 652 | 528 | 443 | --- | --- |
| PHD536 (208/230-1-60) | Low ¹ | Blue | CFM | 921 | 740 | 448 | --- | --- | --- | --- | --- | --- |
| | Med-Low | Pink | CFM | 1019 | 849 | 603 | 479 | --- | --- | --- | --- | --- |
| | Medium | Red | CFM | 1272 | 1203 | 1150 | 1097 | 1054 | 996 | 937 | 881 | 841 |
| | Med-High ² | Orange | CFM | 1321 | 1258 | 1212 | 1168 | 1114 | 1075 | 1009 | 856 | 904 |
| PHD548 (208/230-1-60) | High | Black | CFM | 1478 | 1426 | 1387 | 1334 | 1292 | 1247 | 1212 | 1148 | 1108 |
| | Low ¹ | Blue | CFM | 1201 | 1159 | 1101 | 1062 | 1004 | 957 | 897 | 852 | 793 |
| | Med-Low | Pink | CFM | 1419 | 1364 | 1318 | 1258 | 1214 | 1160 | 1118 | 1053 | 1009 |
| | Medium ² | Red | CFM | 1678 | 1635 | 1602 | 1558 | 1513 | 1474 | 1438 | 1404 | 1349 |
| PHD560 (208/230-1-60) | Med-High | Orange | CFM | 1916 | 1881 | 1846 | 1810 | 1761 | 1722 | 1681 | 1647 | 1600 |
| | High | Black | CFM | 2093 | 2051 | 2024 | 1967 | 1947 | 1907 | 1854 | 1826 | 1749 |
| | Low ¹ | Blue | CFM | 1320 | 1256 | 1211 | 1142 | 1096 | 1028 | 973 | 903 | 835 |
| | Med-Low | Pink | CFM | 1351 | 1295 | 1258 | 1212 | 1170 | 1124 | 1080 | 1036 | 992 |
| PHD560 (208/230-1-60) | Medium ² | Red | CFM | 1824 | 1782 | 1742 | 1711 | 1673 | 1641 | 1607 | 1563 | 1490 |
| | Med-High | Orange | CFM | 2001 | 1958 | 1923 | 1883 | 1831 | 1776 | 1705 | 1624 | 1538 |
| | High | Black | CFM | 2292 | 2238 | 2158 | 2049 | 1935 | 1840 | 1732 | 1635 | 1513 |

* Air delivery values are without air filter and are for dry coil (See PHD5 Wet Coil Pressure Drop Table).

¹ Factory-shipped low stage cooling / low stage heat pump heating speed

² Factory-shipped high stage cooling / low stage heat pump heating speed

NOTE: Deduct field-supplied air filter pressure drop and wet coil pressure drop to obtain external static pressure available for ducting.

Table 5—PHD5 Wet Coil Pressure Drop (in. W.C.)

| UNIT SIZE | STANDARD CFM (S.C.F.M) | | | | | | | | | | | | | | |
|--------------|------------------------|------|------|------|------|------|------|------|------|------|------|------|------|------|------|
| | 600 | 700 | 800 | 900 | 1000 | 1100 | 1200 | 1300 | 1400 | 1500 | 1600 | 1700 | 1800 | 1900 | 2000 |
| 24 | 0.06 | 0.07 | 0.08 | 0.09 | 0.1 | | | | | | | | | | |
| 36 | | | | | 0.07 | 0.11 | 0.18 | 0.26 | 0.35 | | | | | | |
| 48 | | | | | | | | | 0.11 | 0.14 | 0.17 | 0.22 | 0.28 | | |
| 60 | | | | | | | | | | | 0.1 | 0.17 | 0.23 | 0.31 | 0.36 |

Table 6—Filter Pressure Drop Table (in. W.C.)

| Filter Size Inches (mm) | CFM | | | | | | | | | | | | | | | | | | |
|----------------------------|------|------|------|------|------|------|------|------|------|------|------|------|------|------|------|------|------|------|------|
| | 500 | 600 | 700 | 800 | 900 | 1000 | 1100 | 1200 | 1300 | 1400 | 1500 | 1600 | 1700 | 1800 | 1900 | 2000 | 2100 | 2200 | 2300 |
| 20X20X1 (508X508X25) | 0.05 | 0.07 | 0.08 | 0.1 | 0.12 | 0.13 | 0.14 | 0.15 | — | — | — | — | — | — | — | — | — | — | — |
| 20X24X1 (508X610x25) | — | — | — | .09 | .10 | .11 | .13 | .14 | .15 | .16 | — | — | — | — | — | — | — | — | — |
| 24X30X1 (610X762x25) | — | — | — | 0.04 | 0.05 | 0.06 | 0.07 | 0.07 | 0.08 | 0.09 | 0.1 | — | — | — | — | — | — | — | — |
| 24X36X1 (610X914X25) | — | — | — | — | — | — | — | 0.06 | 0.07 | 0.07 | 0.08 | 0.09 | 0.09 | 0.10 | 0.11 | 0.12 | 0.13 | 0.14 | 0.14 |

Table 7—Electric Heat Pressure Drop Table - Small Cabinet: 024 cfm

| | 500 | 600 | 700 | 800 | 900 | 1000 | 1100 | 1200 | 1300 | 1400 | 1500 | 1600 |
|--------|------|------|------|------|------|------|------|------|------|------|------|------|
| 5kw | 0.00 | 0.00 | 0.00 | 0.00 | 0.00 | 0.00 | 0.00 | 0.00 | 0.02 | 0.04 | 0.06 | 0.07 |
| 7.5 kw | 0.00 | 0.00 | 0.00 | 0.00 | 0.00 | 0.00 | 0.02 | 0.03 | 0.05 | 0.07 | 0.08 | 0.09 |
| 10 kw | 0.00 | 0.00 | 0.00 | 0.00 | 0.00 | 0.02 | 0.04 | 0.06 | 0.07 | 0.09 | 0.10 | 0.11 |
| 15 kw | 0.00 | 0.00 | 0.00 | 0.02 | 0.04 | 0.06 | 0.08 | 0.10 | 0.12 | 0.14 | 0.16 | 0.18 |
| 20 kw | 0.00 | 0.00 | 0.02 | 0.04 | 0.06 | 0.08 | 0.09 | 0.11 | 0.13 | 0.15 | 0.17 | 0.19 |

Electric Heat Pressure Drop Table (in. W.C.) - Large Cabinet 036-060 cfm

| | 1100 | 1200 | 1300 | 1400 | 1500 | 1600 | 1700 | 1800 | 1900 | 2000 | 2100 | 2200 | 2300 | 2400 | 2500 |
|--------|------|------|------|------|------|------|------|------|------|------|------|------|------|------|------|
| 5kw | 0.00 | 0.00 | 0.00 | 0.01 | 0.02 | 0.03 | 0.04 | 0.05 | 0.06 | 0.07 | 0.08 | 0.09 | 0.10 | 0.11 | 0.12 |
| 7.5 kw | 0.00 | 0.00 | 0.01 | 0.02 | 0.03 | 0.04 | 0.05 | 0.06 | 0.07 | 0.08 | 0.09 | 0.10 | 0.11 | 0.12 | 0.13 |
| 10 kw | 0.00 | 0.00 | 0.01 | 0.02 | 0.03 | 0.04 | 0.05 | 0.06 | 0.07 | 0.08 | 0.09 | 0.10 | 0.11 | 0.12 | 0.13 |
| 15 kw | 0.00 | 0.02 | 0.03 | 0.04 | 0.05 | 0.06 | 0.07 | 0.08 | 0.09 | 0.10 | 0.11 | 0.12 | 0.13 | 0.14 | 0.15 |
| 20 kw | 0.02 | 0.03 | 0.04 | 0.05 | 0.06 | 0.07 | 0.08 | 0.09 | 0.10 | 0.11 | 0.12 | 0.13 | 0.14 | 0.15 | 0.16 |

| Model Size | | REQUIRED SUBCOOLING °F(°C) | | | | | Required Liquid Line Temperature for a Specific Subcooling (R-410A) | | | | | | | | | | | |
|--|----------|------------------------------------|----------|----------|----------|----------|---|-----|-----|-----|-----|--------------------------|----------------|----|----|----|----|----|
| | | Outdoor Ambient Temperature °F(°C) | | | | | Required Subcooling (°F) | | | | | Required Subcooling (°C) | | | | | | |
| | | 75 (24) | 85 (29) | 95 (35) | 105 (41) | 115 (46) | Pressure (psig) | 5 | 10 | 15 | 20 | 25 | Pressure (kPa) | 3 | 6 | 8 | 11 | 14 |
| 20 | 34 | 12 (6.7) | 12 (6.7) | 12 (6.7) | 11 (6.1) | 11 (6.1) | 189 | 61 | 56 | 51 | 46 | 41 | 1303 | 16 | 13 | 11 | 8 | 5 |
| 30 | 16 (8.9) | 15 (8.3) | 15 (8.3) | 15 (8.3) | 14 (7.8) | 14 (7.8) | 196 | 63 | 58 | 53 | 48 | 43 | 1351 | 17 | 15 | 12 | 9 | 6 |
| 36 | 16 (8.9) | 15 (8.3) | 14 (7.8) | 14 (7.8) | 13 (7.2) | 13 (7.2) | 203 | 66 | 61 | 56 | 51 | 46 | 1399 | 19 | 16 | 13 | 10 | 8 |
| 42 | 14 (7.8) | 14 (7.8) | 13 (7.2) | 13 (7.2) | 13 (7.2) | 210 | 70 | 65 | 60 | 55 | 50 | 48 | 1448 | 20 | 17 | 14 | 11 | 9 |
| 48 | 18 (10) | 17 (9.4) | 17 (9.4) | 17 (9.4) | 17 (9.4) | 217 | 72 | 67 | 62 | 57 | 52 | 50 | 1496 | 21 | 18 | 15 | 13 | 10 |
| 60 | 15 (8.3) | 15 (8.3) | 14 (7.8) | 14 (7.8) | 14 (7.8) | 224 | 74 | 69 | 64 | 59 | 54 | 52 | 1544 | 22 | 19 | 16 | 14 | 11 |
| Charging Procedure | | 231 | 74 | 69 | 64 | 59 | 54 | 52 | 50 | 48 | 46 | 44 | 1593 | 23 | 20 | 18 | 15 | 12 |
| 1- Measure Discharge line pressure by attaching a gauge to the service port. | | 238 | 76 | 71 | 66 | 61 | 56 | 54 | 52 | 50 | 48 | 46 | 1641 | 24 | 21 | 19 | 16 | 13 |
| 2- Measure the Liquid line temperature by attaching a temperature sensing device to it. | | 245 | 77 | 72 | 67 | 62 | 57 | 56 | 54 | 52 | 50 | 48 | 1689 | 25 | 22 | 20 | 17 | 14 |
| 3- Insulate the temperature sensing device so that the Outdoor Ambient doesn't affect the reading. | | 252 | 79 | 74 | 69 | 64 | 59 | 58 | 56 | 54 | 52 | 50 | 1737 | 26 | 23 | 21 | 18 | 15 |
| 4- Refer to the required Subcooling in the table based on the model size and the Outdoor Ambient temperature. | | 260 | 81 | 76 | 71 | 66 | 61 | 60 | 58 | 56 | 54 | 52 | 1792 | 27 | 25 | 22 | 19 | 16 |
| 5- Interpolate if the Outdoor ambient temperature lies in between the table values. | | 268 | 83 | 78 | 73 | 68 | 63 | 62 | 60 | 58 | 56 | 54 | 1848 | 29 | 26 | 23 | 20 | 17 |
| 6- Find the Pressure Value in the table corresponding to the the measured Pressure of the Compressor Discharge line. | | 276 | 85 | 80 | 75 | 70 | 65 | 64 | 62 | 60 | 58 | 56 | 1903 | 30 | 27 | 24 | 21 | 19 |
| 7- Read across from the Pressure reading to obtain the Liquid line temperature for a required Subcooling | | 284 | 87 | 82 | 77 | 72 | 67 | 66 | 64 | 62 | 60 | 58 | 1958 | 31 | 28 | 25 | 22 | 20 |
| 8- Add Charge if the measured temperature is higher than the table value. | | 292 | 89 | 84 | 79 | 74 | 69 | 68 | 66 | 64 | 62 | 60 | 2013 | 32 | 29 | 26 | 23 | 21 |
| 9- Remove charge if the measured temperature is lower than the table value. | | 300 | 91 | 86 | 81 | 76 | 71 | 70 | 68 | 66 | 64 | 62 | 2068 | 33 | 30 | 27 | 24 | 22 |
| | | 309 | 93 | 88 | 83 | 78 | 73 | 72 | 70 | 68 | 66 | 64 | 2130 | 34 | 31 | 28 | 26 | 23 |
| | | 318 | 95 | 90 | 85 | 80 | 75 | 74 | 72 | 70 | 68 | 66 | 2192 | 35 | 32 | 29 | 27 | 24 |
| | | 327 | 97 | 92 | 87 | 82 | 77 | 76 | 74 | 72 | 70 | 68 | 2254 | 36 | 33 | 31 | 28 | 25 |
| | | 336 | 99 | 94 | 89 | 84 | 79 | 78 | 76 | 74 | 72 | 70 | 2316 | 37 | 34 | 32 | 29 | 26 |
| | | 345 | 101 | 96 | 91 | 86 | 81 | 80 | 78 | 76 | 74 | 72 | 2378 | 38 | 35 | 33 | 30 | 27 |
| | | 354 | 103 | 98 | 93 | 88 | 83 | 82 | 80 | 78 | 76 | 74 | 2440 | 39 | 36 | 34 | 31 | 28 |
| | | 364 | 105 | 100 | 95 | 90 | 85 | 84 | 82 | 80 | 78 | 76 | 2509 | 40 | 38 | 35 | 32 | 29 |
| | | 374 | 107 | 102 | 97 | 92 | 87 | 86 | 84 | 82 | 80 | 78 | 2578 | 41 | 39 | 36 | 33 | 30 |
| | | 384 | 108 | 103 | 98 | 93 | 88 | 87 | 85 | 83 | 81 | 79 | 2647 | 42 | 40 | 37 | 34 | 31 |
| | | 394 | 110 | 105 | 100 | 95 | 90 | 89 | 87 | 85 | 83 | 81 | 2716 | 44 | 41 | 38 | 35 | 32 |
| | | 404 | 112 | 107 | 102 | 97 | 92 | 91 | 89 | 87 | 85 | 83 | 2785 | 45 | 42 | 39 | 36 | 33 |
| | | 414 | 114 | 109 | 104 | 99 | 94 | 93 | 91 | 89 | 87 | 85 | 2854 | 46 | 43 | 40 | 37 | 34 |
| | | 424 | 116 | 111 | 106 | 101 | 96 | 95 | 93 | 91 | 89 | 87 | 2923 | 47 | 44 | 41 | 38 | 35 |
| | | 434 | 118 | 113 | 108 | 103 | 98 | 97 | 95 | 93 | 91 | 89 | 2992 | 48 | 45 | 42 | 39 | 36 |
| | | 444 | 119 | 114 | 109 | 104 | 99 | 98 | 96 | 94 | 92 | 90 | 3061 | 48 | 46 | 43 | 40 | 37 |
| | | 454 | 121 | 116 | 111 | 106 | 101 | 100 | 98 | 96 | 94 | 92 | 3130 | 49 | 47 | 44 | 41 | 38 |
| | | 464 | 123 | 118 | 113 | 108 | 103 | 102 | 100 | 98 | 96 | 94 | 3199 | 50 | 48 | 45 | 42 | 39 |
| | | 474 | 124 | 119 | 114 | 109 | 104 | 103 | 101 | 99 | 97 | 95 | 3268 | 51 | 48 | 46 | 43 | 40 |
| | | 484 | 126 | 121 | 116 | 111 | 106 | 105 | 103 | 101 | 99 | 97 | 3337 | 52 | 49 | 47 | 44 | 41 |
| | | 494 | 127 | 122 | 117 | 112 | 107 | 106 | 104 | 102 | 100 | 98 | 3406 | 53 | 50 | 47 | 45 | 42 |
| | | 504 | 129 | 124 | 119 | 114 | 109 | 108 | 106 | 104 | 102 | 100 | 3475 | 54 | 51 | 48 | 46 | 43 |
| | | 514 | 131 | 126 | 121 | 116 | 111 | 110 | 108 | 106 | 104 | 102 | 3544 | 55 | 52 | 49 | 46 | 44 |
| | | 524 | 132 | 127 | 122 | 117 | 112 | 111 | 109 | 107 | 105 | 103 | 3612 | 56 | 53 | 50 | 47 | 45 |
| | | 534 | 134 | 129 | 124 | 119 | 114 | 113 | 111 | 109 | 107 | 105 | 3681 | 56 | 54 | 51 | 48 | 45 |

50VTS00173 REV.4.0

Electrical Controls and Wiring

Inspect and check the electrical controls and wiring annually. Be sure to turn off the electrical power to the unit.

Remove access panels to locate all the electrical controls and wiring, see fig. 12. Check all electrical connections for tightness. Tighten all screw connections. If any discolored or burned connections are noticed, disassemble the connection, clean all the parts, restrip the wire end and reassemble the connection properly and securely.

After inspecting the electrical controls and wiring, replace all the panels. Start the unit, and observe at least one complete cooling cycle to ensure proper operation. If discrepancies are observed in operating cycle, or if a suspected malfunction has occurred, check each electrical component with the proper electrical instrumentation. Refer to the unit wiring label when making these checkouts.

Refrigerant Circuit

Inspect all refrigerant tubing connections and the unit base for oil accumulation annually. Detecting oil generally indicates a refrigerant leak.

If oil is detected or if low performance is suspected, leak-test all refrigerant tubing using an electronic leak detector, or liquid-soap solution. If a refrigerant leak is detected, refer to Check for Refrigerant Leaks section.

If no refrigerant leaks are found and low performance is suspected, refer to Checking and Adjusting Refrigerant Charge section.

Indoor Airflow

The heating and/or cooling airflow does not require checking unless improper performance is suspected. If a problem exists, be sure that all supply-air and return-air grilles are open and free from obstructions, and that the air filter is clean. When necessary, refer to Indoor Airflow and Airflow Adjustments section to check the system airflow.

Metering Devices-TXV & Piston

This unit uses 2 types of metering devices. The outdoor metering device is a fixed orifice and is contained in the brass hex-body in each liquid line feeding the outdoor coils. The indoor metering device is a TXV type device.

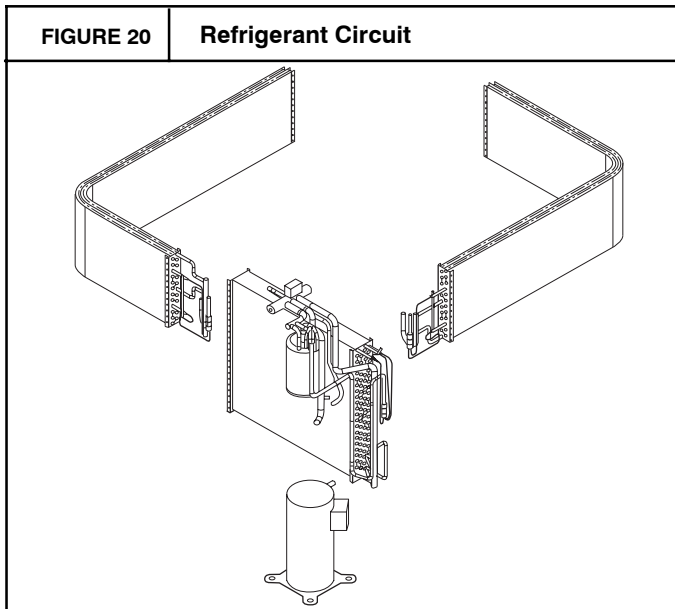

Pressure Switches

Pressure switches are protective devices wired into control circuit (low voltage). They shut off compressor if abnormally high or low pressures are present in the refrigeration circuit. These

pressure switches are specifically designed to operate with R-410A systems. R-22 pressure switches must not be used as replacements for the R-410A system.

Loss of Charge Switch

This switch is located on the liquid line and protects against low suction pressures caused by such events as loss of charge, low airflow across indoor coil, dirty filters, etc. It opens on a pressure drop at about 20 psig. If system pressure is above this, switch should be closed. To check switch:

1. Turn off all power to unit.
2. Disconnect leads on switch.
3. Apply ohm meter leads across switch. You should have continuity on a good switch.

NOTE: Because these switches are attached to refrigeration system under pressure, it is not advisable to remove this device for troubleshooting unless you are reasonably certain that a problem exists. If switch must be removed, remove and recover all system charge so that pressure gauges read 0 psi. Never open system without breaking vacuum with dry nitrogen.

High-Pressure Switches

The high-pressure switches are located on the discharge line and protect against excessive condenser coil pressure.

High pressure may be caused by a dirty outdoor coil, failed fan motor, or outdoor air recirculation.

To check switch:

1. Turn off all power to unit.
2. Disconnect leads on switch.
3. Apply ohm meter leads across switch. You should have continuity on a good switch.

Copeland Scroll Compressor (R-410A Refrigerant)

The compressor used in this product is specifically designed to operate with R-410A refrigerant and cannot be interchanged.

⚠ WARNING

EXPLOSION HAZARD

Failure to follow this warning could result in personal injury, death or property damage.

Wear safety glasses and gloves when handling refrigerants. Keep torches and other ignition sources away from refrigerant and oils.

The scroll compressor pumps refrigerant throughout the system by the interaction of a stationary and an orbiting scroll. The scroll compressor has no dynamic suction or discharge valves, and it is more tolerant of stresses caused by debris, liquid slugging, and flooded starts. The compressor is equipped with an internal pressure relief port. The pressure relief port is a safety device, designed to protect against extreme high pressure. The relief port has an operating range between 550 and 625 psi differential pressure.

Refrigerant System

This step covers the refrigerant system, including the compressor oil needed, servicing systems on roofs containing synthetic materials, the filter drier and refrigerant charging.

Refrigerant

WARNING

PROPERTY HAZARD, PERSONAL INJURY OR ENVIRONMENTAL HAZARD

Failure to follow this warning could result in property damage or personal injury or death.

This system uses R-410A refrigerant which has higher operating pressures than R-22 and other refrigerants. No other refrigerant may be used in this system. Gauge set, hoses, and recovery system must be designed to handle R-410A. If you are unsure consult the equipment manufacturer.

Compressor Oil

The Copeland scroll compressor uses 3MAF POE oil. If additional oil is needed, use Uniqema RL32-3MAF. If this oil is not available, use Copeland Ultra 32 CC or Mobil Arctic EAL22 CC. This oil is extremely hygroscopic, meaning it absorbs water readily. POE oils can absorb 15 times as much water as other oils designed to HCFC and CFC refrigerants. Take all necessary precautions to avoid exposure of the oil to the atmosphere.

Servicing Systems on Roofs with Synthetic Materials

POE (polyolester) compressor lubricants are known to cause long term damage to some synthetic roofing materials. Exposure, even if immediately cleaned up, may cause embrittlement (leading to cracking) to occur in one year or more. When performing any service that may risk exposure of compressor oil to the roof, take appropriate precautions to protect roofing. Procedures which risk oil leakage include, but are not limited to, compressor replacement, repairing refrigerant leaks, replacing refrigerant components such as filter drier, pressure switch, metering device, coil, accumulator, or reversing valve.

Synthetic Roof Precautionary Procedure

1. Cover extended roof working area with an impermeable polyethylene (plastic) drip cloth or tarp. Cover an approximate 10x10 ft (3x3 m) area.
2. Cover area in front of the unit service panel with a terry cloth shop towel to absorb lubricant spills and prevent run-offs, and protect drop cloth from tears caused by tools or components.
3. Place terry cloth shop towel inside unit immediately under component(s) to be serviced and prevent lubricant run-offs through the louvered openings in the unit base.
4. Perform required service.
5. Remove and dispose of any oil contaminated material per local codes.

Liquid Line Filter Drier

The biflow filter drier is specifically designed to operate with R-410A. Use only factory-authorized components. Filter drier must be replaced whenever the refrigerant system is opened. When removing a filter drier, use a tubing cutter to cut the drier from the system. Do not unsweat a filter drier from the system. Heat from unsweating will release moisture and contaminants from drier into system.

R-410A Refrigerant Charging

Refer to unit information plate and charging chart. Some R-410A refrigerant cylinders contain a dip tube to allow liquid refrigerant to flow from cylinder in upright position. For cylinders equipped with a dip tube, charge R-410A units with cylinder in upright position and a commercial metering device in manifold hose. Charge refrigerant into suction-line.

System Information

Loss of Charge Switch

The loss of charge switch is a protective device wired into control circuit (low voltage). It shuts off the compressor if abnormally low pressures are present in the refrigeration circuit.

NOTE: Because these switches are attached to refrigeration system under pressure, it is not advisable to remove this device for troubleshooting unless you are reasonably certain that a problem exists. If switch must be removed, remove and recover all system charge so that pressure gauges read 0 psi. Never open system without breaking vacuum with dry nitrogen.

Check Defrost Thermostat

The defrost thermostat is usually located on the lowest liquid leaving circuit of the left condenser coil (see Fig. 22). The thermostat closes at 32°F (0°C) and opens at 65°F (18°C).

The defrost thermostat signals heat pump that conditions are right for defrost or that conditions have changed to terminate defrost. It is a thermally actuated switch clamped to outdoor coil to sense its temperature. Normal temperature range is closed at 32° ± 3°F (0 ± 1.7°C) and open at 65° ± 5°F (18 ± 2.8°C).

NOTE: The defrost thermostat must be located on the liquid side of the outdoor coil on the bottom circuit and as close to the coil as possible.

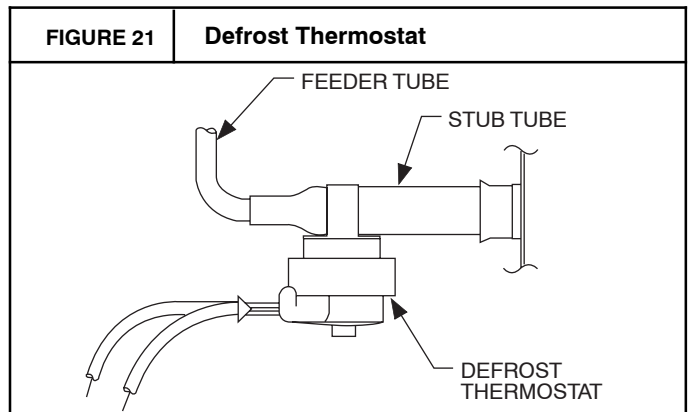

TROUBLESHOOTING

Refer to the Cooling and Heating Troubleshooting Chart (Table 8) for troubleshooting information.

START-UP CHECKLIST

Use the Start-Up Checklist.

R-410A QUICK REFERENCE GUIDE

- R-410A refrigerant operates at 50–70 percent higher pressures than R-22. Be sure that servicing equipment and replacement components are designed to operate with R-410A refrigerant.
- R-410A refrigerant cylinders are rose colored.
- Recovery cylinder service pressure rating must be 400 psig, DOT 4BA400 or DOT BW400.
- R-410A systems should be charged with liquid refrigerant. Use a commercial type metering device in the manifold hose when charging into suction line with compressor operating
- Manifold sets should be 700 psig high side and 180 psig low side with 550 psig low-side retard.
- Use hoses with 700 psig service pressure rating.
- Leak detectors should be designed to detect HFC refrigerant.
- R-410A, as with other HFCs, is only compatible with POE oils.
- Vacuum pumps will not remove moisture from oil.
- Do not use liquid-line filter driers with rated working pressures less than 600 psig.
- Do not leave R-410A suction line filter driers in line longer than 72 hours.
- Do not install a suction-line filter drier in liquid line.
- POE oils absorb moisture rapidly. Do not expose oil to atmosphere.
- POE oils may cause damage to certain plastics and roofing materials.
- Wrap all filter driers and service valves with wet cloth when brazing.
- A factory approved liquid-line filter drier is required on every unit.
- Do NOT use an R-22 TXV.
- If indoor unit is equipped with an R-22 TXV or piston metering device, it must be changed to a hard shutoff R-410A TXV.
- Never open system to atmosphere while it is under a vacuum.
- When system must be opened for service, recover refrigerant, evacuate then break vacuum with dry nitrogen and replace filter driers. Evacuate to 500 microns prior to recharging.
- Do not vent R-410A refrigerant into the atmosphere.
- Do not use capillary tube coils.
- Observe all **warnings**, **cautions**, and **bold** text.
- All indoor coils must be installed with a hard shutoff R-410A TXV metering device.

Table 8—Troubleshooting Chart

| SYMPTOM | CAUSE | REMEDY |
|---|---|--|
| Compressor and condenser fan will not start. | Power failure | Call power company |
| | Fuse blown or circuit breaker tripped | Replace fuse or reset circuit breaker |
| | Defective contactor, transformer, or high-pressure, loss-of-charge or low-pressure switch | Replace component |
| | Insufficient line voltage | Determine cause and correct |
| | Incorrect or faulty wiring | Check wiring diagram and rewire correctly |
| | Thermostat setting too high | Lower thermostat setting below room temperature |
| Compressor will not start but condenser fan runs | Faulty wiring or loose connections in compressor circuit | Check wiring and repair or replace |
| | Compressor motor burned out, seized, or internal overload open | Determine cause Replace compressor |
| | Defective run/start capacitor, overload, start relay | Determine cause and replace |
| Compressor cycles (other than normally satisfying thermostat). | Refrigerant overcharge or undercharge | Recover refrigerant, evacuate system, and recharge to capacities shown on rating plate |
| | Defective compressor | Replace and determine cause |
| | Insufficient line voltage | Determine cause and correct |
| | Blocked condenser | Determine cause and correct |
| | Defective run/start capacitor, overload or start relay | Determine cause and replace |
| | Defective thermostat | Replace thermostat |
| | Faulty condenser-fan motor or capacitor | Replace |
| | Restriction in refrigerant system | Locate restriction and remove |
| Compressor operates continuously | Dirty air filter | Replace filter |
| | Unit undersized for load | Decrease load or increase unit size |
| | Thermostat set too low | Reset thermostat |
| | Low refrigerant charge | Locate leak, repair, and recharge |
| | Mechanical damage in compressor | Replace compressor |
| | Air in system | Recover refrigerant, evacuate system, and recharge |
| | Condenser coil dirty or restricted | Clean coil or remove restriction |
| Excessive head pressure | Dirty air filter | Replace filter |
| | Dirty condenser coil | Clean coil |
| | Refrigerant overcharged | Recover excess refrigerant |
| | Air in system | Recover refrigerant, evacuate system, and recharge |
| | Condenser air restricted or air short-cycling | Determine cause and correct |
| Head pressure too low | Low refrigerant charge | Check for leaks, repair, and recharge. |
| | Compressor IPR leaking | Replace compressor |
| | Restriction in liquid tube | Remove restriction |
| Excessive suction pressure | High heat load | Check for source and eliminate |
| | Compressor IPR leaking | Replace compressor |
| | Refrigerant overcharged | Recover excess refrigerant |
| Suction pressure too low | Dirty air filter | Replace filter |
| | Low refrigerant charge | Check for leaks, repair and recharge |
| | Metering device or low side restricted | Remove source of restriction |
| | Insufficient evaporator airflow | Increase air quantity Check filter—replace if necessary |
| | Temperature too low in conditioned area | Reset thermostat |
| | Outdoor ambient below 55°F (12.7°C) | Install low-ambient kit |
| | Filter drier restricted | Replace filter |

START-UP CHECKLIST

(Remove and Store in Job Files)

I. PRELIMINARY INFORMATION

MODEL NO.: _____

SERIAL NO.: _____

DATE: _____

TECHNICIAN: _____

II. PRESTART-UP (Insert check mark in box as each item is completed)

- VERIFY THAT ALL PACKING MATERIALS HAVE BEEN REMOVED FROM UNIT
- REMOVE ALL SHIPPING HOLD DOWN BOLTS AND BRACKETS PER INSTALLATION INSTRUCTIONS
- CHECK ALL ELECTRICAL CONNECTIONS AND TERMINALS FOR TIGHTNESS
- CHECK THAT INDOOR (EVAPORATOR) AIR FILTER IS CLEAN AND IN PLACE
- VERIFY THAT UNIT INSTALLATION IS LEVEL
- CHECK FAN WHEEL, AND PROPELLER FOR LOCATION IN HOUSING/ORIFICE AND SETSCREW TIGHTNESS
- MAKE SURE THAT - (If Applicable) ON 60 SIZE R-410A HEAT PUMP ONLY, THE TWO WIRE TIES FASTEN TO THE OUTDOOR COILS AND REVERSING VALVE/ACCUMULATOR HAVE BEEN REMOVED

III. START-UP

ELECTRICAL

SUPPLY VOLTAGE _____

COMPRESSOR AMPS _____

INDOOR (EVAPORATOR) FAN AMPS _____

TEMPERATURES

OUTDOOR (CONDENSER) AIR TEMPERATURE _____ DB

RETURN-AIR TEMPERATURE _____ DB _____ WB

COOLING SUPPLY AIR _____ DB _____ WB

HEAT PUMP SUPPLY AIR _____

ELECTRIC HEAT SUPPLY AIR _____

PRESSURES

REFRIGERANT SUCTION _____ PSIG, SUCTION LINE TEMP* _____

REFRIGERANT DISCHARGE _____ PSIG, LIQUID TEMP† _____

VERIFY REFRIGERANT CHARGE USING CHARGING CHARTS

TEMPERATURE RISE (See Literature) RANGE _____

MEASURED TEMPERATURE RISE _____

* Measured at suction inlet to compressor

† Measured at liquid line leaving condenser.