

# INSTALLATION INSTRUCTIONS

## R-410A Single Package Rooftop Gas/Electric RGS210-336 Vertical Supply and Return with RTPF

These instructions must be read and understood completely before attempting installation

### Safety Labeling and Signal Words

#### DANGER, WARNING, CAUTION, and NOTE

The signal words **DANGER**, **WARNING**, **CAUTION**, and **NOTE** are used to identify levels of hazard seriousness. The signal word **DANGER** is only used on product labels to signify an immediate hazard. The signal words **WARNING**, **CAUTION**, and **NOTE** will be used on product labels and throughout this manual and other manual that may apply to the product.

**DANGER** – Immediate hazards which will result in severe personal injury or death.

**WARNING** – Hazards or unsafe practices which could result in severe personal injury or death.

**CAUTION** – Hazards or unsafe practices which may result in minor personal injury or product or property damage.

**NOTE** – Used to highlight suggestions which will result in enhanced installation, reliability, or operation.

#### Signal Words in Manuals

The signal word **WARNING** is used throughout this manual in the following manner:

 **WARNING**

The signal word **CAUTION** is used throughout this manual in the following manner:

 **CAUTION**

#### Signal Words on Product Labeling

Signal words are used in combination with colors and/or pictures or product labels.

#### TABLE OF CONTENTS

SAFETY CONSIDERATIONS .....	2S
RATED AIRFLOW .....	2
MODEL NOMENCLATURE .....	3
DIMENSIONS AND WEIGHTS .....	4
INSTALLATION .....	10
Step 1 – Plan for Unit Location .....	10
Step 2 – Plan for Sequence of Unit Installation ...	10
Step 3 – Inspect Unit .....	10
Step 4 – Provide Unit Support .....	12
Step 5 – Field Fabricate Ductwork .....	16
Step 6 – Rig and Place Unit .....	16
Step 7 – Install Outside Air Hood .....	17
Step 8 – Install Flue Hood .....	18
Step 9 – Install Gas Piping .....	18
Step 10 – Install External condensate Trap & Piping .....	21
Step 11 – Make Electrical Connections .....	21
Step 12 – Adjust Factory-Installed Options .....	33
Step 13 – Install Accessories .....	33
START-UP CHECKLIST .....	34

 **WARNING**

#### **PERSONAL INJURY, AND/OR PROPERTY DAMAGE HAZARD**

Failure to carefully read and follow this warning could result in equipment malfunction, property damage, personal injury and/or death.

Installation or repairs made by unqualified persons could result in equipment malfunction, property damage, personal injury and/or death.

The information contained in this manual is intended for use by a qualified service technician familiar with safety procedures and equipped with proper tools and test instruments.

Installation must conform with local building codes and with the national Electrical Code NFPA70 current edition or Canadian Electrical Code part 1 CSA C.22.1.

## SAFETY CONSIDERATIONS

Improper installation, adjustment, alteration, service, maintenance, or use can cause explosion, fire, electrical shock or other conditions which may cause personal injury or property damage. Consult a qualified installer, service agency, or your distributor or branch for information or assistance. The qualified installer or agency must use factory-authorized kits or accessories when modifying this product. Refer to the individual instructions packaged with the kits or accessories when installing.

Follow all safety codes. Wear safety glasses and work gloves. Use quenching cloths for brazing operations and have a fire extinguisher available. Read these instructions thoroughly and follow all warnings or cautions attached to the unit. Consult local building codes and appropriate national electrical codes (in USA, ANSI/NFPA70, National Electrical Code (NEC); in Canada, CSA C22.1) for special requirements.

Recognize safety information. This is the safety-alert symbol . When you see this symbol in instructions or manuals, be alert to the potential for personal injury.

Understand the signal words **DANGER**, **WARNING**, **CAUTION**, and **NOTE**. These words are used with the safety-alert symbol. **DANGER** identifies the most serious hazards which **will** result in serious injury or death. **WARNING** signifies a hazard which **could** result in serious injury or death. **CAUTION** is used to identify unsafe practices which **may** result in minor personal injury or product and property damage. **NOTE** is used to highlight suggestions which **will** result in enhanced installation, reliability, or operation.

These instructions cover minimum requirements and conform to existing national standards and safety codes. In some instances, these instructions exceed certain local codes and ordinances, especially those that may not have kept up with changing residential construction practices. We require these instructions as a minimum for a safe installation.

### **WARNING**

#### **FIRE, EXPLOSION HAZARD**

Failure to follow this warning could result in personal injury or death.

Disconnect gas piping from unit when leak testing at pressure greater than 0.5 psig (3450 Pa). Pressures greater than 0.5 psig (3450 Pa) will cause gas valve damage resulting in hazardous condition. If gas valve is subjected to pressure greater than 0.5 psig (3450 Pa), it must be replaced before use. When pressure testing field-supplied gas piping at pressures of 0.5 psig (3450 Pa) or less, a unit connected to such piping must be isolated by closing the manual gas valve.

### **WARNING**

#### **ELECTRICAL SHOCK HAZARD**

Failure to follow this warning could cause personal injury or death.

Before performing service or maintenance operations on unit, always turn off main power switch to unit and install locks and lockout tags. Unit may have more than one power switch.

### **WARNING**

#### **UNIT OPERATION AND SAFETY HAZARD**

Failure to follow this warning could cause personal injury, death and/or equipment damage.

R-410A refrigerant systems operate at higher pressures than standard R-22 systems. Do not use R-22 service equipment or components on R-410A refrigerant equipment.

### **WARNING**

#### **PERSONAL INJURY AND ENVIRONMENTAL HAZARD**

Failure to follow this warning could cause personal injury or death

Relieve pressure and recover all refrigerant before system repair or final unit disposal.

Wear safety glasses and gloves when handling refrigerants. Keep torches and other ignition sources away from refrigerants and oils.

### **CAUTION**

#### **CUT HAZARD**

Failure to follow this caution may result in personal injury.

Sheet metal parts may have sharp edges or burrs. Use care and wear appropriate protective clothing, safety glasses and gloves when handling parts and servicing air conditioning units.

The table below list the rated indoor airflow used for the AHRI efficiency rating for the units covered in this document.

Model Number	Full Load Airflow (cfm)
RGS210	6125
RGS240	8000
RGS300	8750
RGS336	9750

# MODEL NOMENCLATURE FOR RGS VERTICAL UNITS

MODEL SERIES	R	G	S	2	1	0	H	D	A	B	0	A	A	A
<b>Position Number</b>	1	2	3	4	5	6	7	8	9	10	11	12	13	14
R = Rooftop														
G = Gas/Electric	<b>Type</b>													
S = Standard ASHRAE 90.1-2010 Efficiency	<b>Efficiency</b>													
210 = 210,000 = 17.5 Tons Dedicated Vertical SA/RA (SA = Supply Air, RA = Return Air) 240 = 240,000 = 20 Tons Dedicated Vertical SA/RA 300 = 300,000 = 25 Tons Dedicated Vertical SA/RA 336 = 330,000 = 27.5 Tons Dedicated Vertical SA/RA <div style="text-align: right;"><b>Nominal Cooling Capacity</b></div>														
H = 208/230-3-60 L = 460-3-60 S = 575-3-60 <div style="text-align: right;"><b>Voltage</b></div>														
D = Low Heat E = Medium Heat F = High Heat S = Low Heat, Stainless Steel Heat Exchanger R = Medium Heat, Stainless Steel Heat Exchanger T = High Heat, Stainless Steel Heat Exchanger <div style="text-align: right;"><b>Heating Capacity</b></div>														
A = Standard Static Option (all sizes, with 1-speed and 2-speed indoor fan motor) B = High Static Option (all sizes, with 2-speed indoor fan motor) C = Medium Static Option (17.5 ton, with 1-speed indoor fan motor, all sizes with 2-speed indoor fan motor) E = High Static High Efficiency Option (all sizes, with 1-speed indoor fan motor) F = Medium Static High Efficiency Option (20, 25, 27.5 ton, with 1-speed indoor fan motor) G = High Static Motor with Hot Gas Re-heat (20, 25, 27.5 ton, with 1-speed indoor fan motor) <div style="text-align: right;"><b>Motor Option</b></div>														
A = None B = Economizer w/Bara-relief, OA Temp sensor E = Economizer w/Bara-relief + CO <sub>2</sub> sensor, OA Temp sensor H = Economizer w/Bara-relief, Enthalpy sensor L = Economizer w/Bara-relief + CO <sub>2</sub> sensor, Enthalpy sensor U = Ultra Low Leak Temp Economizer w/Bara-relief (2-speed indoor fan motor only) W = Ultra Low Leak Temp Enthalpy Economizer w/Bara-relief (2-speed indoor fan motor only) P = 2-Position damper <div style="text-align: right;"><b>Outdoor Air Options / Control</b></div>														
OA = No Options 4B = Non-fused Disconnect AA = Hinged Access Panels AT = Non-powered 115v Convenience Outlet. BR = Supply Air Smoke Detector <div style="text-align: right;"><b>Other Factory Installed Options</b></div>														
A = Alum / Cu Cond & Alum / Cu Evap B = Pre coated Alum / Cu Cond & Alum / Cu Evap C = E-coated Alum / Cu Cond & Alum / Cu Evap D = E-coated Alum / E-coated Cu Cond & Alum / Cu Evap E = Cu / Cu Cond & Alum / Cu Evap F = Cu / Cu Cond & Cu / Cu Evap <div style="text-align: right;"><b>Coil Factory Installed Options</b></div>														
A = Standard Motor T = 2 Speed Indoor Fan VFD Controller (For 2-stage units only) <div style="text-align: right;"><b>Motor Type Option</b></div>														

**FIGURE 1 Unit Dimensional Drawing: 17.5 Ton, RGS210**

THIS DOCUMENT IS THE PROPERTY OF CARRIER CORPORATION AND IS BELIEVED UPON THE EXPRESS CONDITION THAT THE CONTENTS WILL NOT BE DISCLOSED OR USED WITHOUT CARRIER CORPORATION'S WRITTEN CONSENT.

UNITED TECHNOLOGIES SPRINGFIELD, NY  
CARRIER

50HE501150  
CC13727

CONNECTION SIZES	
A	1 3/8" DIA [35] FIELD POWER SUPPLY KNOCKOUT
B	3" DIA [76] FIELD POWER SUPPLY KNOCKOUT
C	3 5/8" DIA [92] FIELD POWER SUPPLY KNOCKOUT
D	7/8" DIA [22] FIELD CONTROL WIRING HOLE
E	3/4"-14 NPT CONDENSATE DRAIN
F	3/4"-14 NPT GAS CONNECTION (NOT SHOWN)
G	7/8" DIA [22] FIELD CONTROL WIRING KNOCKOUT

- NOTES:
1. DIMENSIONS ARE IN INCHES. DIMENSIONS IN [ ] ARE IN MILLIMETERS.
  2. CENTER OF GRAVITY
  3. DIRECTION OF AIR FLOW

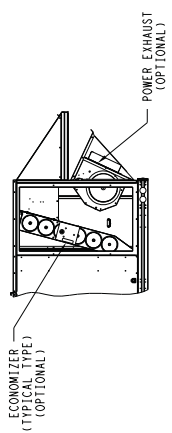
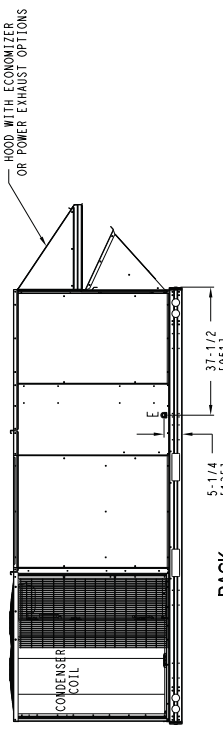
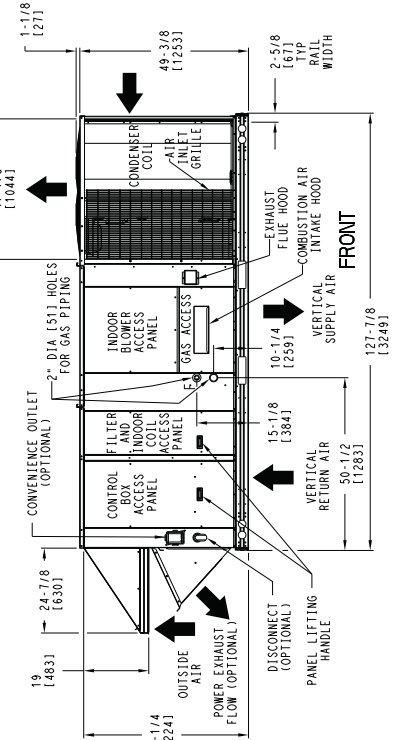
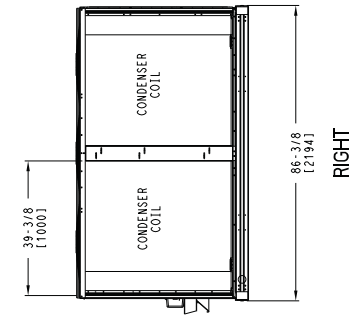
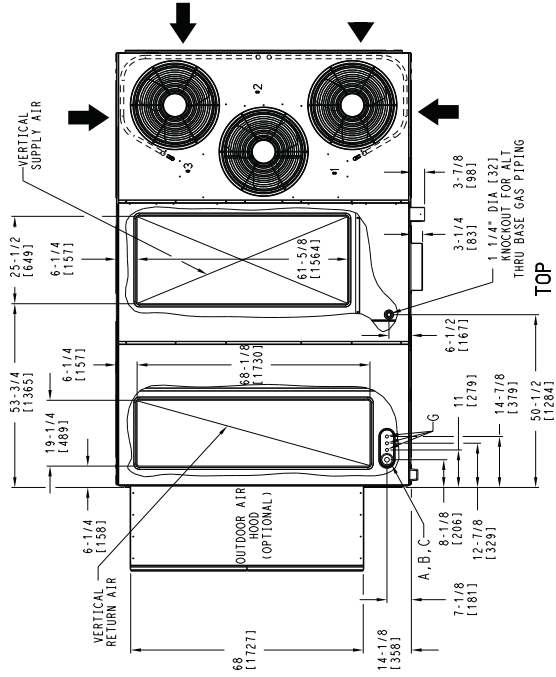

**BACK**  
IPANELS REMOVED TO SHOW ECONOMIZER AND POWER EXHAUST OPTIONS

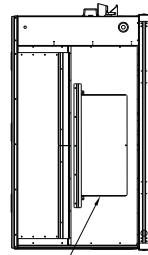

BAROMETRIC RELIEF (OPTIONAL) INCLUDED WITH ECONOMIZER

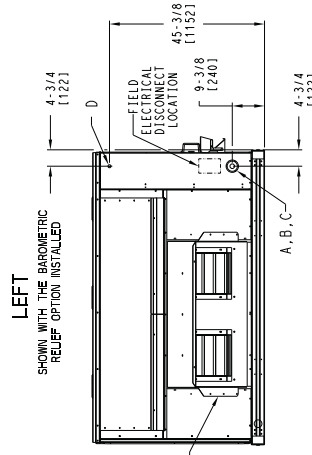

**LEFT**

SHOWN WITH THE BAROMETRIC RELIEF OPTION INSTALLED

**LEFT**

SHOWN WITH THE POWER EXHAUST OPTION INSTALLED

**Figure 1 – Unit Dimensional Drawing: 17.5 Ton: RGS210**

Unit Size	Unit Weight		Corner Weight (A)		Corner Weight (B)		Corner Weight (C)		Corner Weight (D)		C.G.		
	Lb	Kg	Lb	Kg	Lb	Kg	Lb	Kg	Lb	Kg	X	Y	Z
17.5 Ton	1992	874	441	201	523	238	519	236	438	199	42-7/8 [1090]	69-1/4 [1759]	16-1/2 [419]

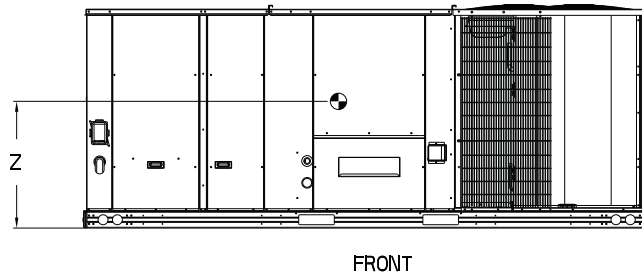
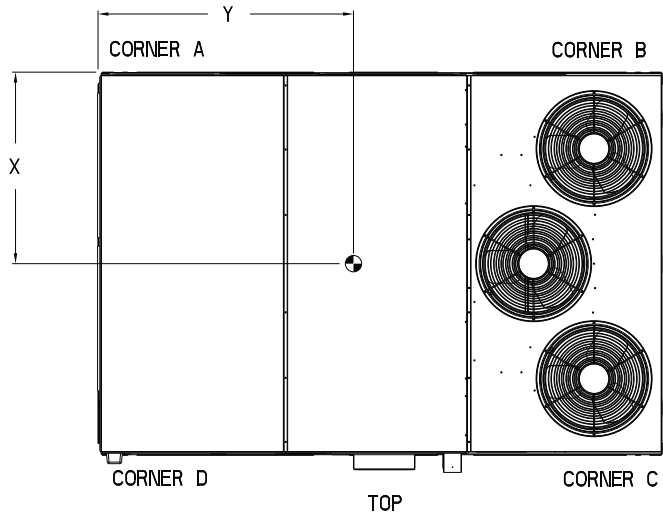

50HE501150  
C13729

**FIGURE 2 – Unit Dimensional Drawing: 20 & 25 Ton, RGS240 & 300**

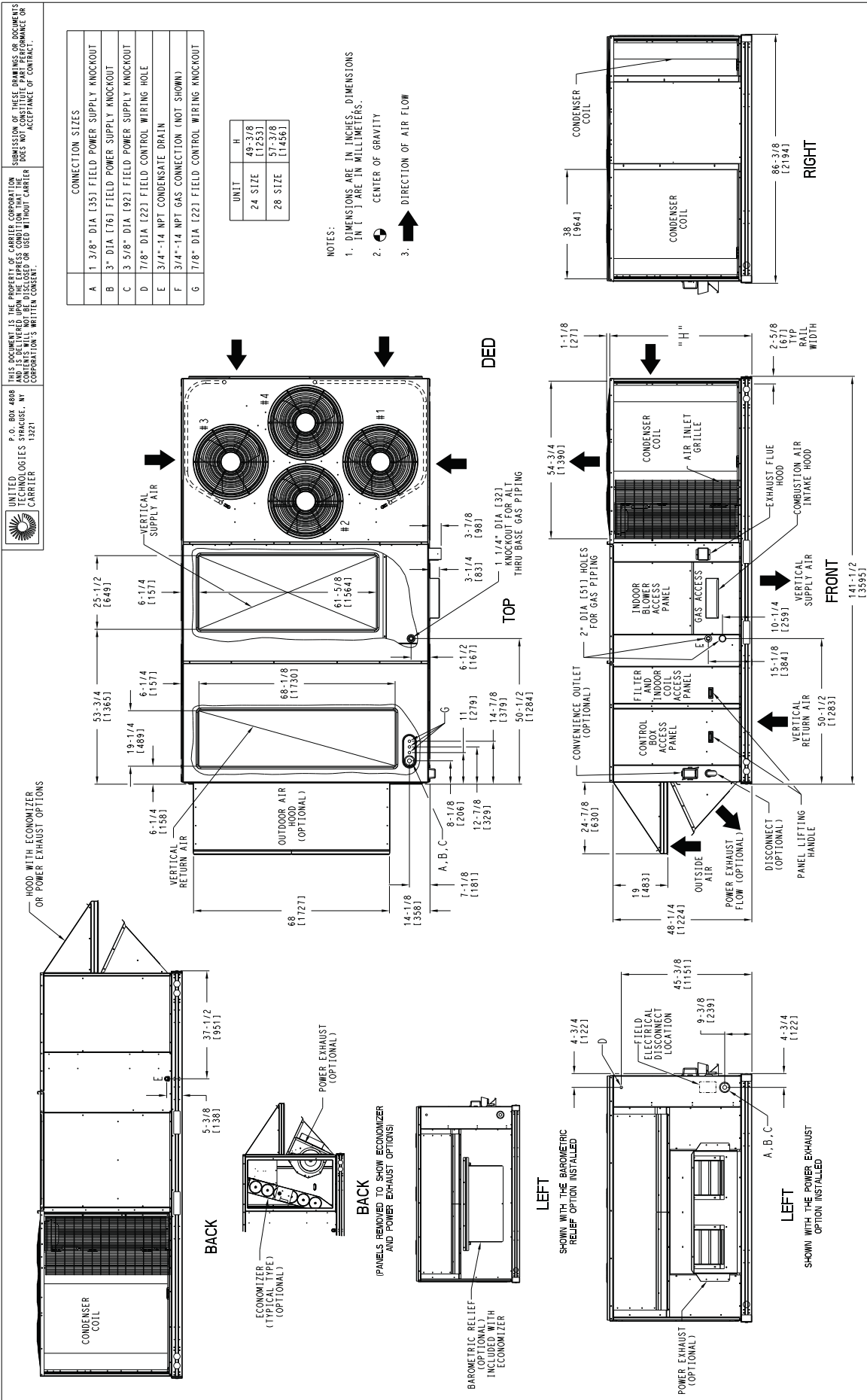

50HE501158

CC13733

**Figure 2 – Unit Dimensional Drawing: 20 & 25 Ton, RGS240, 300**

Unit Size	Unit Weight		Corner Weight (A)		Corner Weight (B)		Corner Weight (C)		Corner Weight (D)		C.G.		
	Lb	Kg	Lb	Kg	Lb	Kg	Lb	Kg	Lb	Kg	X	Y	Z
20 Ton	2072	942	558	254	548	249	479	217	487	221	40-1/8 [1020]	70 [1778]	16-1/2 [419]
25 Ton	2197	999	571	259	564	256	528	240	534	243	41-11/16 [1058]	70-1/4 [1784]	19 [493]

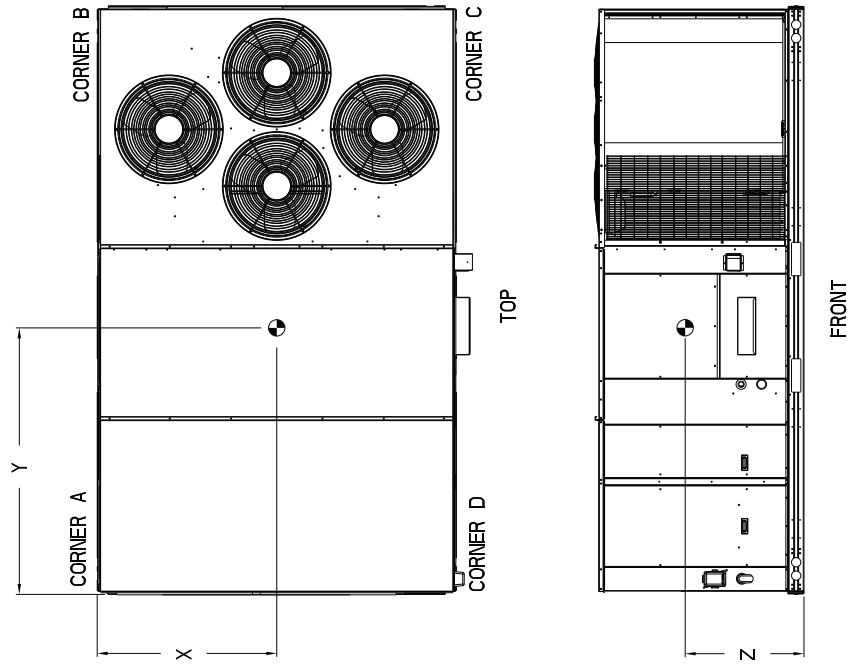

50HE501158  
CC13736



**Figure 3 – Unit Dimensional Drawing: 27.5 Ton, RGS27.5**

Unit Size	Unit Weight		Corner Weight (A)		Corner Weight (B)		Corner Weight (C)		Corner Weight (D)		C.G.		
	Lb	Kg	Lb	Kg	Lb	Kg	Lb	Kg	Lb	Kg	X	Y	Z
27.5 Ton	2640	1200	697	317	595	270	621	282	728	331	44 [1058]	72-1/2 [1842]	19 [493]

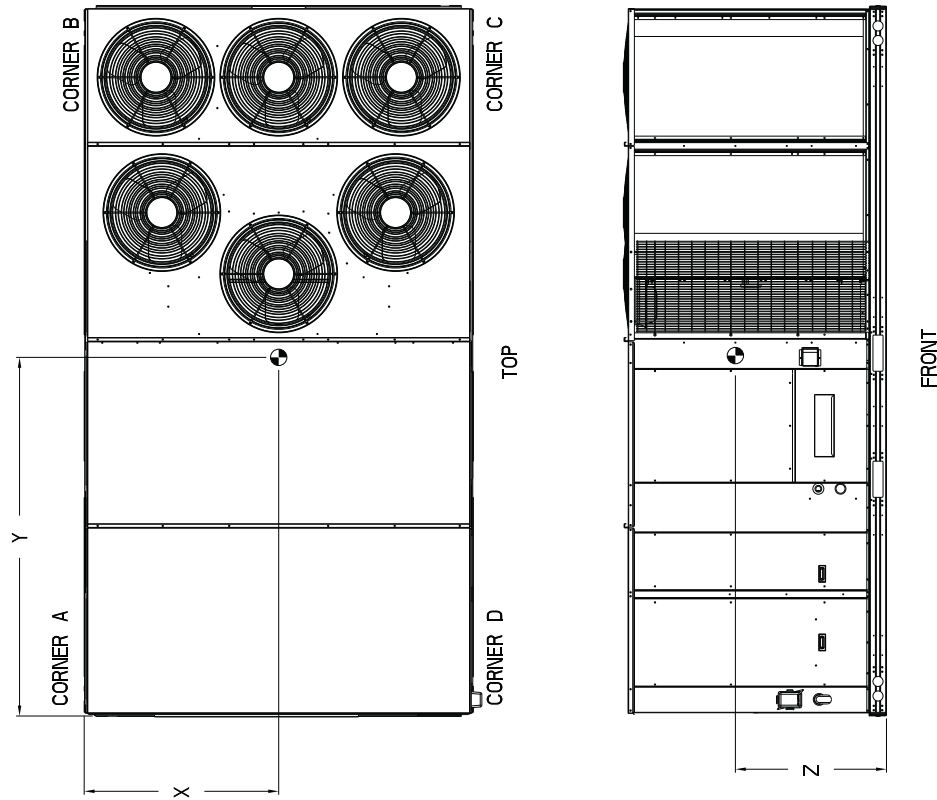

50HE502174  
CC13741

# INSTALLATION

## Jobsite Survey

Complete the following checks before installation.

1. Consult local building codes and the NEC (National Electrical Code) ANSI/NFPA 70 for special installation requirements.
2. Determine unit location (from project plans) or select unit location.
3. Check for possible overhead obstructions which may interfere with unit lifting or rigging.

## Step 1 — Plan for Unit Location

Select a location for the unit and its support system (curb or other) that provides for the minimum clearances required for safety. This includes the clearance to combustible surfaces, unit performance and service access below, around and above unit as specified in unit drawings. See FIGURE 4.

**NOTE:** Consider also the effect of adjacent units.

Be sure that the unit is installed such that snow will not block the combustion air intake or flue outlet.

Unit may be installed directly on wood flooring or on Class A, B, or C roof-covering material when roof curb is used.

Do not install unit in an indoor location. Do not locate air inlets near exhaust vents or other sources of contaminated air. For proper unit operation, adequate combustion and ventilation air must be provided in accordance with Section 5.3 (Air for Combustion and Ventilation) of the National Fuel Gas Code, ANSI Z223.1 (American National Standards Institute) and NFPA (National Fire Protection Association) 54 TIA-54-84-1. In Canada, installation must be in accordance with the CAN1-B149 installation codes for gas burning appliances.

Although unit is weatherproof, avoid locations that permit water from higher level runoff and overhangs to fall onto the unit.

Locate mechanical draft system flue assembly at least 4 ft (1.2 m) from any opening through which combustion products could enter the building, and at least 4 ft (1.2 m) from any adjacent building (or per local code). Locate the flue assembly at least 10 ft (3.05 m) from an adjacent unit's fresh air intake hood if within 3 ft (0.91 m) of same elevation (or per local code). When unit is located adjacent to public walkways, flue assembly must be at least 7 ft (2.1 m) above grade.

Select a unit mounting system that provides adequate height to allow installation of condensate trap per requirements. Refer to Step 10 — Install External Condensate Trap and Line — for required trap dimensions.

## Roof Mount —

Check building codes for weight distribution requirements. Unit operating weight is shown in Table 1.

## Step 2 — Plan for Sequence of Unit Installation

The support method used for this unit will dictate different sequences for the steps of unit installation. For example, on curb-mounted units, some accessories must be installed on the unit before the unit is placed on the curb. Review the following for recommended sequences for installation steps.

### Curb-mounted installation —

- Install curb
- Install field-fabricated ductwork inside curb
- Install thru-base service connection fittings (affects curb and unit)
- Rig and place unit
- Remove top skid
- Install outside air hood
- Install smoke detector tube
- Install combustion air hood
- Install flue hood
- Install gas piping
- Install condensate line trap and piping
- Make electrical connections
- Install other accessories

### Pad-mounted installation —

- Prepare pad and unit supports
- Rig and place unit
- Remove duct covers and top skid
- Install smoke detector return air sensor tube
- Install field-fabricated ductwork at unit duct openings
- Install outside air hood
- Install combustion air hood
- Install flue hood
- Install gas piping
- Install condensate line trap and piping
- Make electrical connections
- Install other accessories

### Frame-mounted installation —

Frame-mounted applications generally follow the sequence for a curb installation. Adapt as required to suit specific installation plan.

## Step 3 — Inspect unit

Inspect unit for transportation damage. File any claim with transportation agency.

Confirm before installation of unit that voltage, amperage and circuit protection requirements listed on unit data plate agree with power supply provided.

Locate the carton containing the outside air hood parts; See 6 and 12. Do not remove carton until unit has been rigged and located in final position.

**FIGURE 4 – Service Clearance Dimensional Drawing**

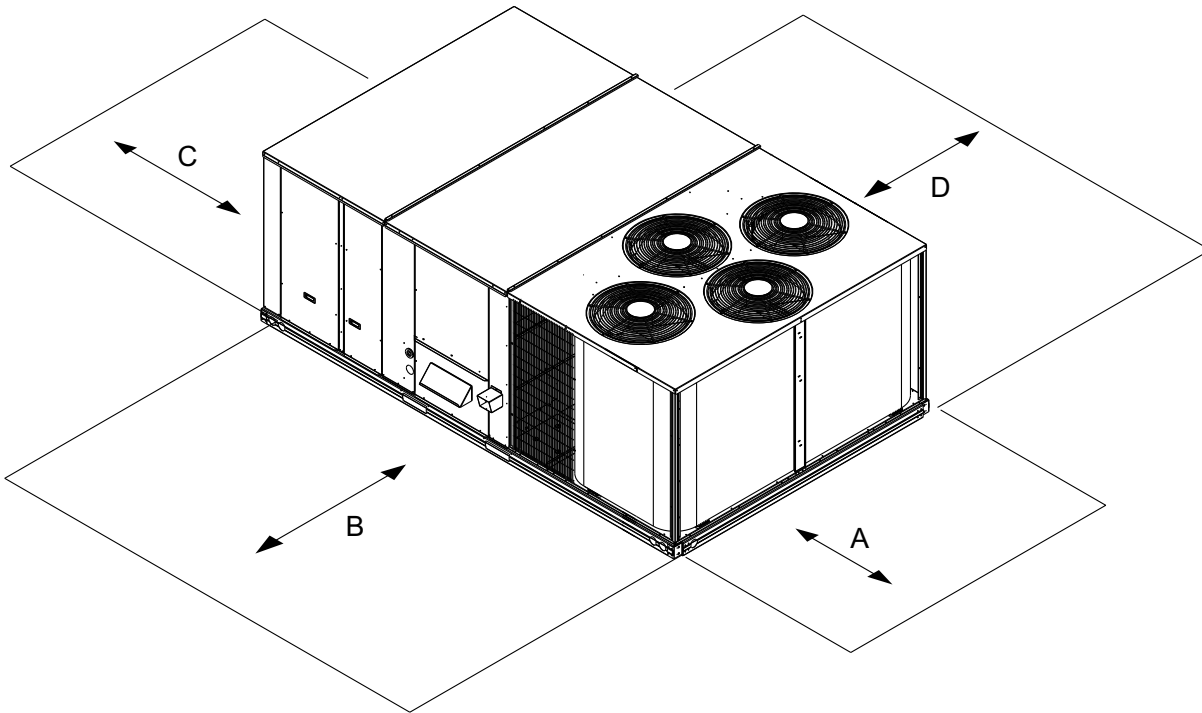

C12384

LOCATION	DIMENSION	CONDITION
A	36-in (914 mm)	• Recommended clearance for air flow and service
B	42-in (1067 mm)	• Recommended clearance for air flow and service
C	18-in (457 mm)	• No Convenience Outlet • No Economizer • No field installed disconnect on economizer hood side (Factory-installed disconnect installed).
	36-in (914 mm)	• Convenience Outlet installed. • Vertical surface behind servicer is electrically non-conductive (e.g.: wood, fiberglass).
	42-in (1067 mm)	• Convenience Outlet installed. • Vertical surface behind servicer is electrically conductive (e.g.: metal, masonry).
	96-in (2438 mm)	• Economizer and/or Power Exhaust installed. • Check for sources of flue products with 10 feet (3 meters) of economizer fresh air intake.
D	42-in (1067 mm)	• Recommended clearance for service.

**NOTE:** Unit not designed to have overhead obstruction. Contact Application Engineering for guidance on any application planning overhead obstruction or for vertical clearances.

**Table 1—Operating Weights**

RGS	UNIT LB (KG)			
	210	240	300	336
Base Unit				
RTPF Coil	1922 (874)	2072 (942)	2197 (999)	2640 (1200)
Economizer	246 (112)	246 (112)	246 (112)	246 (112)
Hot Gas Reheat	110 (50)	120 (54)	120 (54)	N/A
Curb				
14-in/356 mm	240 (109)	255 (116)	255 (116)	255 (116)
24-in/610 mm	340 (154)	355 (161)	355 (161)	355 (161)

## Step 4 — Provide Unit Support

### Roof Curb Mount —

Accessory roof curb details and dimensions are shown in FIGURE 7, FIGURE 8 and FIGURE 9. Assemble and install accessory roof curb in accordance with instructions shipped with the curb.

**NOTE:**The gasketing of the unit to the roof curb is critical for a watertight seal. Install gasket supplied with the roof curb as shown in FIGURE 7, FIGURE 8 and FIGURE 9. Improperly applied gasket can also result in air leaks and poor unit performance.

Curb should be level. This is necessary for unit drain to function properly. Unit leveling tolerances are shown in FIGURE 5. Refer to Accessory Roof Curb Installation Instructions for additional information as required.

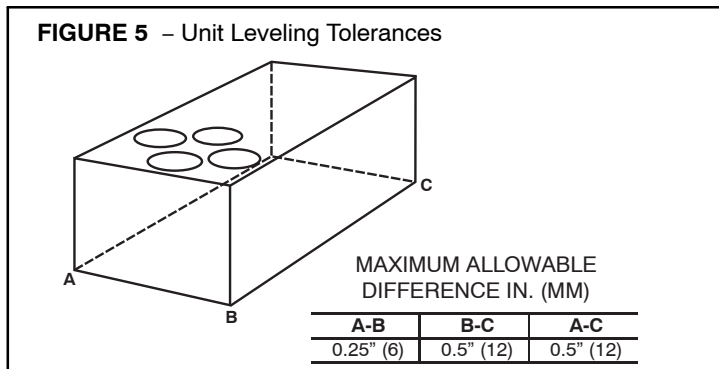

C10628

Install insulation, cant strips, roofing felt, and counter flashing as shown. *Ductwork must be attached to curb and not to the unit. Thru-the-base power connection must be installed before the unit is set on the roof curb.* If field-installed thru-the-roof curb gas connections are desired remove knockout in basepan located in the gas section, see

FIGURE 6 for location. Gas connections and power connections to the unit must be field installed after the unit is installed on the roof curb.

If electric and control wiring is to be routed through the basepan, remove knockouts in basepan located in control box area of access panel; see FIGURE 1, FIGURE 2 or FIGURE 3 for basepan knockout locations for location. Attach the service connections to the basepan.

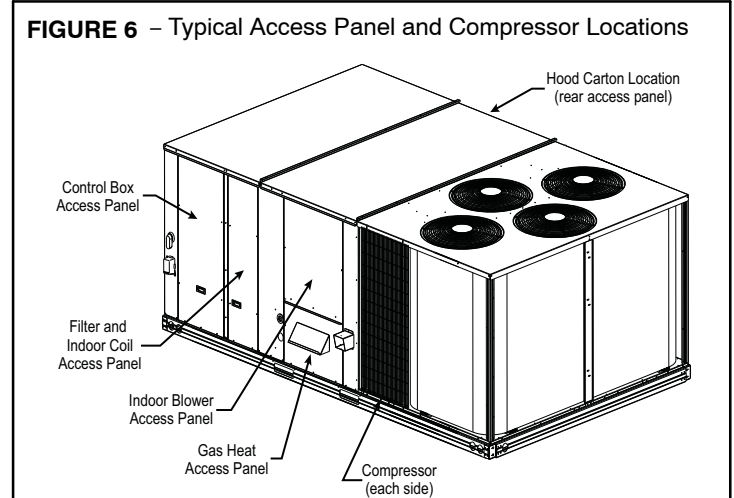

C11154

### Alternate Unit Support (In Lieu of Curb Mount) —

A non-combustible sleeper rail can be used in the unit curb support area. If sleeper rails cannot be used, support the long sides of the unit with a minimum of 4 equally spaced 4-in. x 4-in. (102 mm x 102 mm) pads on each side. Locate pads so that they support the rails. Make sure to avoid the fork openings.

**FIGURE 7 – Roof Curb Details, RGS210**

UNIT SIZE	"A"	ROOF CURB ACCESSORY
17,20	1'-2" [356.0] 2'-0" [610.0]	CRRFCURB045A00 CRRFCURB046A00

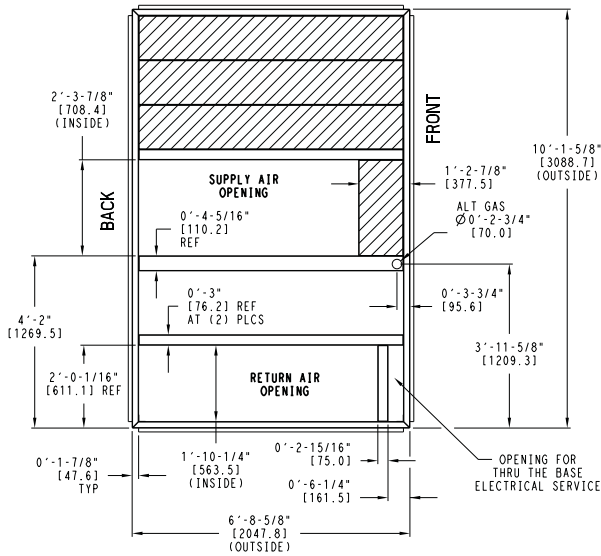

**NOTES:**

- 1 ROOF CURB ACCESSORY IS SHIPPED UNASSEMBLED.
- 2 DIMENSIONS IN [ ] ARE IN MILLIMETERS.
- 3 ROOF CURB GALVANIZED STEEL.
- 4 ATTACH DUCTWORK TO CURB (FLANGES ON DUCT REST ON CURB)
- 5 SERVICE CLEARANCE 4 FT ON EACH SIDE

➔ DIRECTION OF AIR FLOW

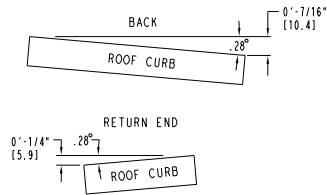

**MAX CURB LEVELING TOLERANCES**

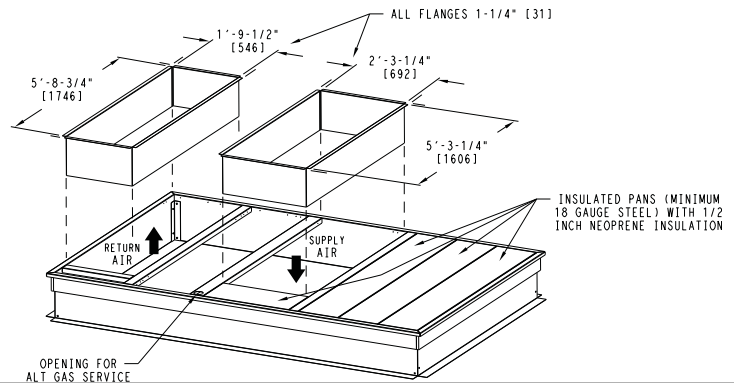
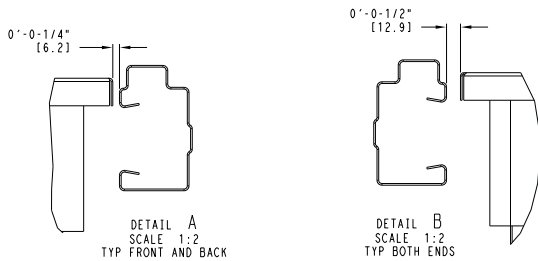
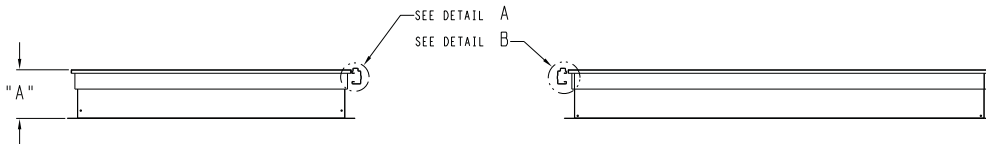
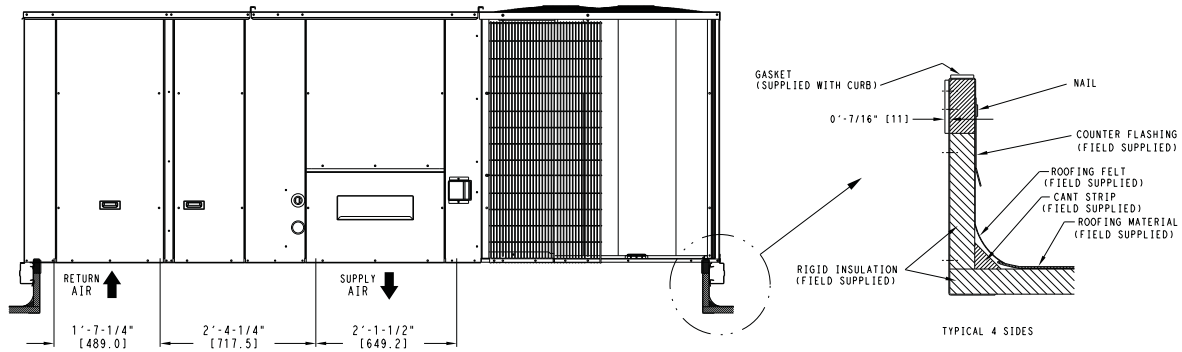

**FIGURE 8 – Roof Curb Details, RGS240 & RGS300**

UNIT SIZE	"A"	ROOF CURB ACCESSORY
24.28	1'-2" [356.0] 2'-0" [610.0]	CRRFCURB047A00 CRRFCURB048A00

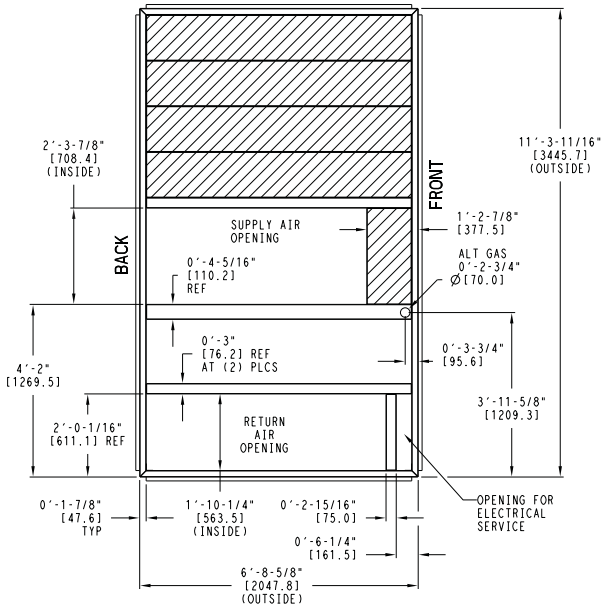

**NOTES:**

- 1 ROOF CURB ACCESSORY IS SHIPPED UNASSEMBLED.
- 2 DIMENSIONS IN [ ] ARE IN MILLIMETERS.
- 3 ROOF CURB GALVANIZED STEEL.
- 4 ATTACH DUCTWORK TO CURB (FLANGES ON DUCT REST ON CURB)
- 5 SERVICE CLEARANCE 4 FT ON EACH SIDE

➔ DIRECTION OF AIR FLOW

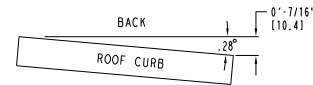

**MAX CURB LEVELING TOLERANCES**

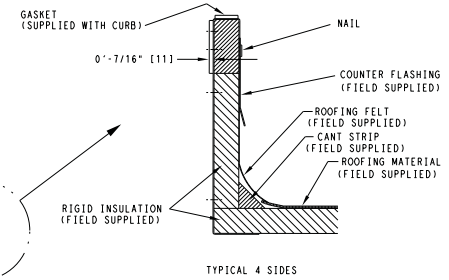
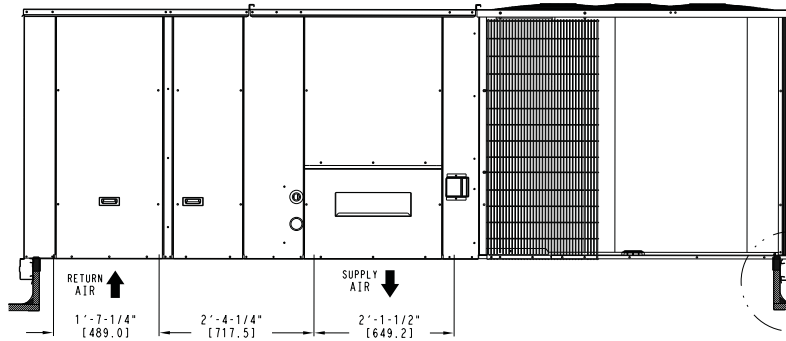

TYPICAL 4 SIDES

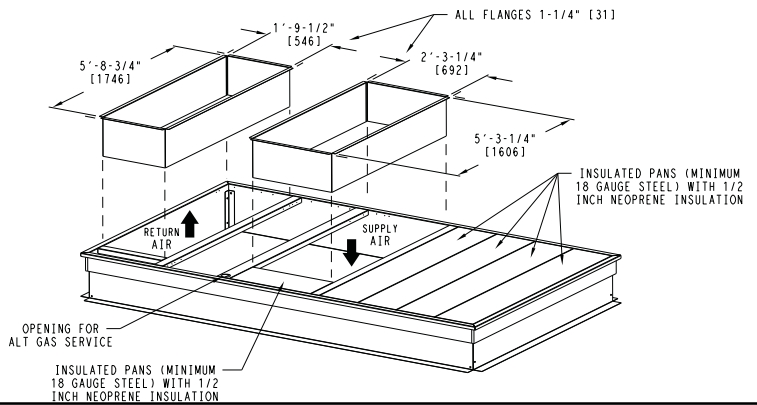
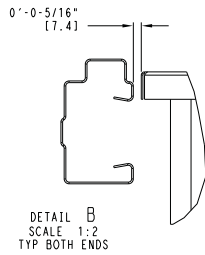
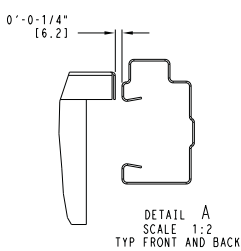
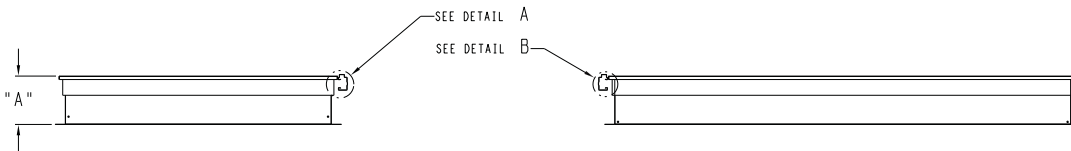

**FIGURE 9 – Roof Curb Details, RGS336**

UNIT SIZE	"A"	ROOF CURB ACCESSORY
30	1'-2" [356.0] 2'-0" [610.0]	CRRFCURB049A00 CRRFCURB050A00

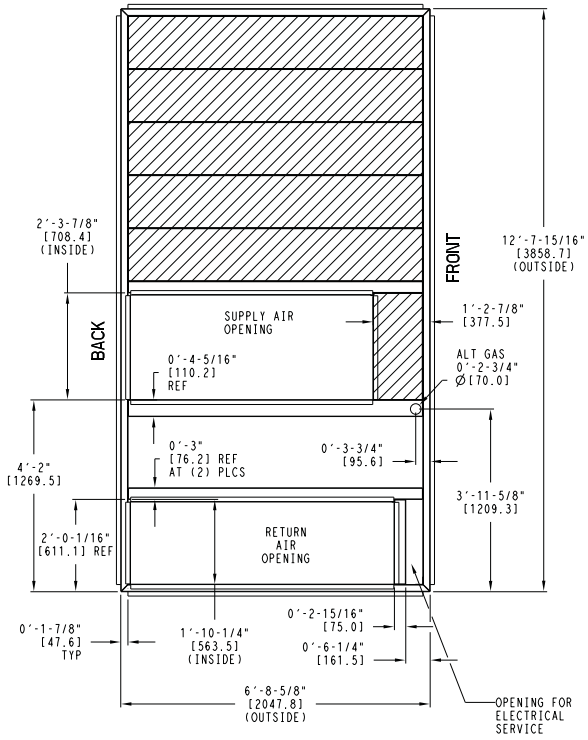

- NOTES:
- 1 ROOF CURB ACCESSORY IS SHIPPED UNASSEMBLED.
  - 2 BOLT HEADS TO BE ON INSIDE OF FLANGE. CLEARANCE IS (11) 0-0-7/16" TYP ALL CORNERS.
  - 3 DIMENSIONS IN ( ) ARE IN MILLIMETERS.
  - 4 ROOF CURB GALVANIZED STEEL.
  - 5 ATTACH DUCTWORK TO CURB (FLANGES ON DUCT REST ON CURB)
  - 6 SERVICE CLEARANCE 4 FT ON EACH SIDE
  - 7 GAS SERVICE PLATE IS PART OF A SEPARATELY SHIPPED ACCESSORY PACKAGE.
  - 8 GAS SERVICE PLATE CAN BE USED WITH EITHER ACCESSORY ROOFCURB.

➔ DIRECTION OF AIR FLOW

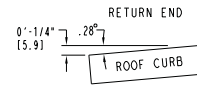
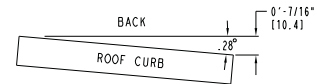

MAX CURB LEVELING TOLERANCES

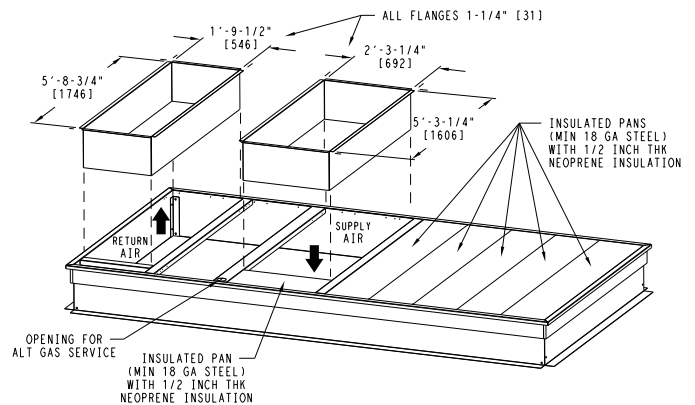
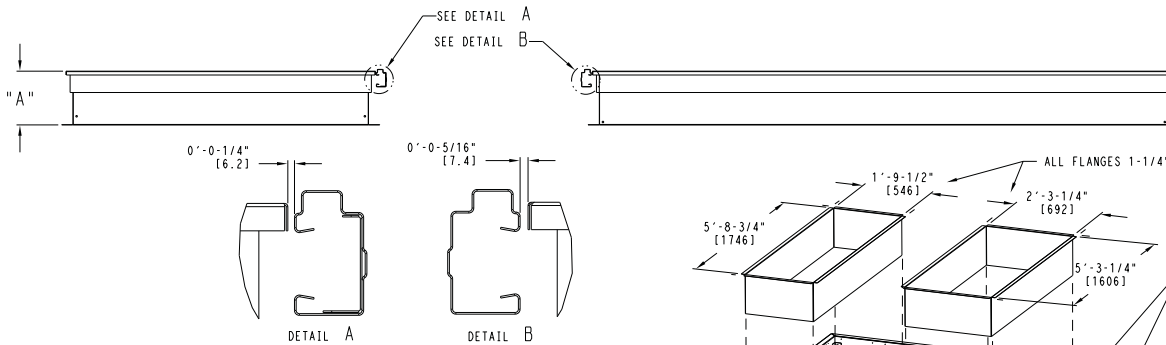
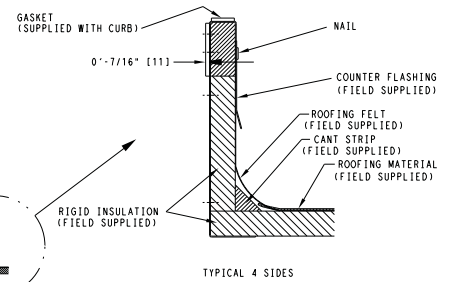
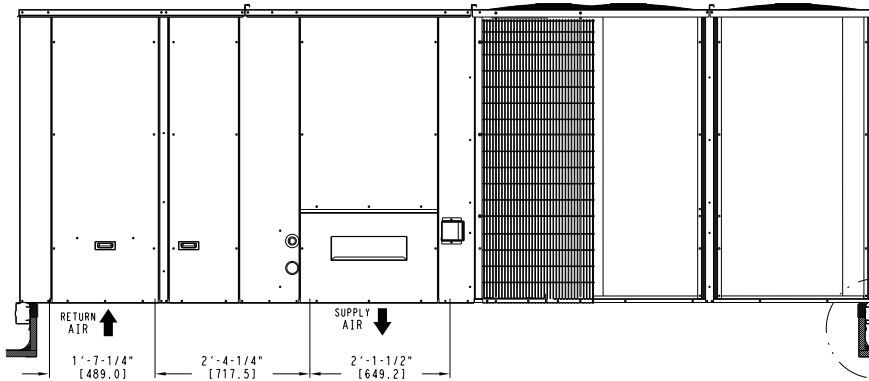

## Step 5 — Field Fabricate Ductwork

Cabinet return-air static pressure (a negative condition) shall not exceed 0.5 in. wg (87 Pa) with economizer or without economizer.

For vertical ducted applications, secure all ducts to roof curb and building structure. *Do not connect ductwork to unit.*

Fabricate supply ductwork so that the cross sectional dimensions are equal to or greater than the unit supply duct opening dimensions for the first 18 in. (458 mm) of duct length from the unit basepan.

Insulate and weatherproof all external ductwork, joints, and roof openings with counter flashing and mastic in accordance with applicable codes.

Ducts passing through unconditioned spaces must be insulated and covered with a vapor barrier.

If a plenum return is used on a vertical unit, the return should be ducted through the roof deck to comply with applicable fire codes.

A minimum clearance is not required around ductwork.

### ⚠ CAUTION

#### PROPERTY DAMAGE HAZARD

Failure to follow this caution may result in damage to roofing materials.

Membrane roofs can be cut by sharp sheet metal edges. Be careful when placing any sheet metal parts on such roof.

## Step 6 — Rig and Place Unit

Keep unit upright and do not drop. Spreader bars are not required if top crating is left on unit. Rollers may be used to move unit across a roof. Level by using unit frame as a reference. See Table 1 and Fig. FIGURE 10 (below) for additional information.

Lifting holes are provided in base rails as shown in FIGURE 10 Refer to rigging instructions on unit.

### ⚠ CAUTION

#### UNIT DAMAGE HAZARD

Failure to follow this caution may result in equipment damage.

All panels must be in place when rigging. Unit is not designed for handling by fork truck when packaging is removed.

Before setting the unit onto the curb, recheck gasketing on curb.

FIGURE 10 Rigging Details

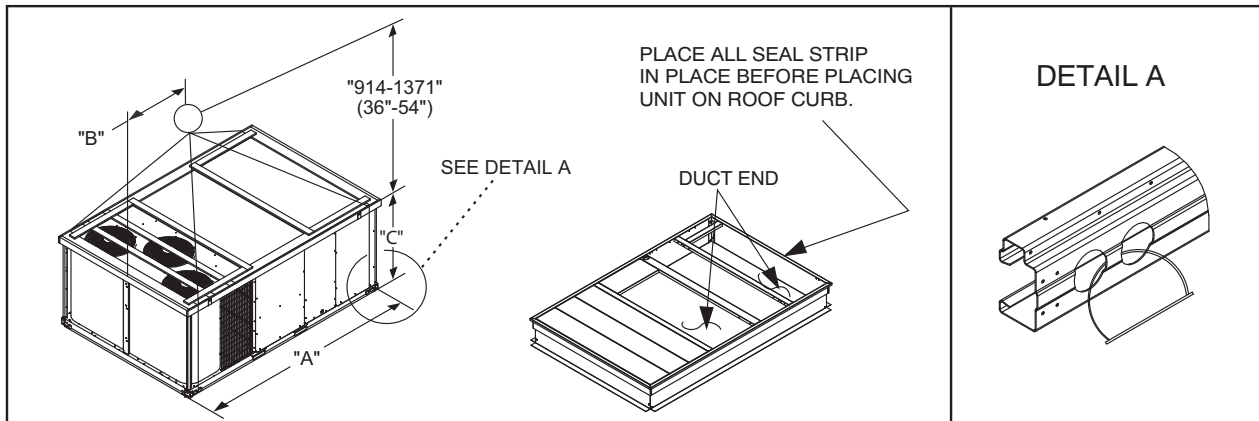

C09107

UNIT	MAX WEIGHT		DIMENSIONS					
			A		B		C	
	LB	KG	IN	MM	IN	MM	IN	MM
RGS210	2370	1075	127.8	3249	58.7	1491	52.3	1328
RGS240	2516	1141	141.5	3595	71.5	1816	52.3	1328
RGS300	2652	1203	141.5	3595	71.5	1816	60.3	1532
RGS336	2976	1353	157.8	4007	80.3	2040	60.3	1532

#### NOTES:

1. Dimensions in ( ) are in inches.
2. Hook rigging shackles through holes in base rail, as shown in detail "A." Holes in base rails are centered around the unit center of gravity.
3. Use wooden top skid, when rigging, to prevent rigging straps from damaging unit.

## Positioning on Curb —

Position unit on roof curb so that the following clearances are maintained:  $\frac{1}{4}$  in. (6 mm) clearance between the roof curb and the base rail inside the right and left,  $\frac{1}{2}$  in. (12 mm) clearance between the roof curb and the base rail inside the front and back. This will result in the distance between the roof curb and the base rail inside on the condenser end of the unit being approximately equal to Details A and B in Figs. FIGURE 7, FIGURE 8 and FIGURE 9.

Do not attempt to slide unit on curb after unit is set. Doing so will result in damage to the roof curb seal.

Although unit is weatherproof, guard against water from higher level runoff and overhangs.

*Flue vent discharge must have a minimum horizontal clearance of 48 in. (1220 mm) from electric and gas meters, gas regulators, and gas relief equipment. Minimum distance between unit and other electrically live parts is 48 inches (1220 mm).*

Flue gas can deteriorate building materials. Orient unit such that flue gas will not affect building materials. Locate mechanical draft system flue assembly at least 48 in. (1220 mm) from an adjacent building or combustible material.

After unit is in position, remove rigging skids and shipping materials.

## Step 7 — Install Outside Air Hood — Factory Option

The outside air hood for factory-option economizer and two-position damper is shipped in knock-down form and requires field assembly. The panel for the hood top is shipped on the end of the unit (see FIGURE 11). The remaining parts for the hood assembly (including side panels, filters and tracks) are shipped in a carton that is secured to the rear of the blower assembly. Access the carton location through rear panel (see FIGURE 12).

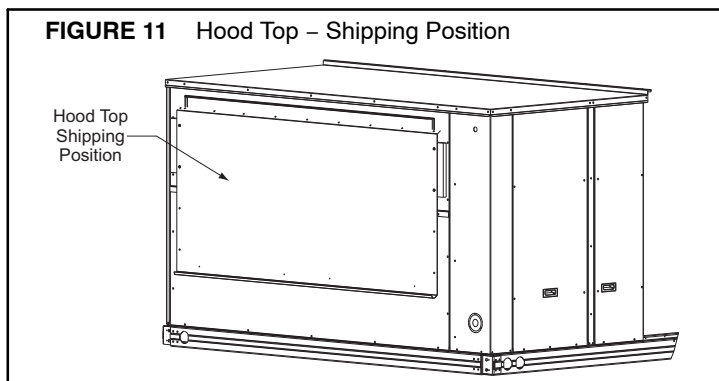

C09134

FIGURE 12 Hood Package – Shipping Location

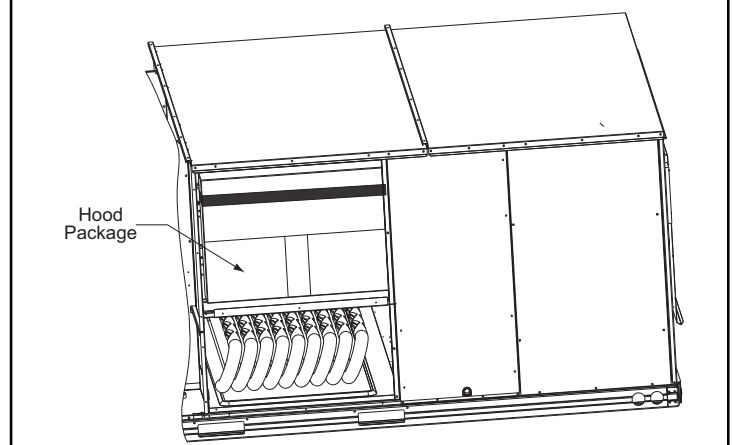

C09133

### To remove the hood parts package:

1. Remove the back blower access panel.
2. Locate and cut the strap, being careful to not damage any wiring.
3. Carefully lift the hood package carton through the back blower access opening.

see FIGURE 13 for identification of the various parts of the hood assembly.

FIGURE 13 Hood Part Identification and Seal Strip Application Areas

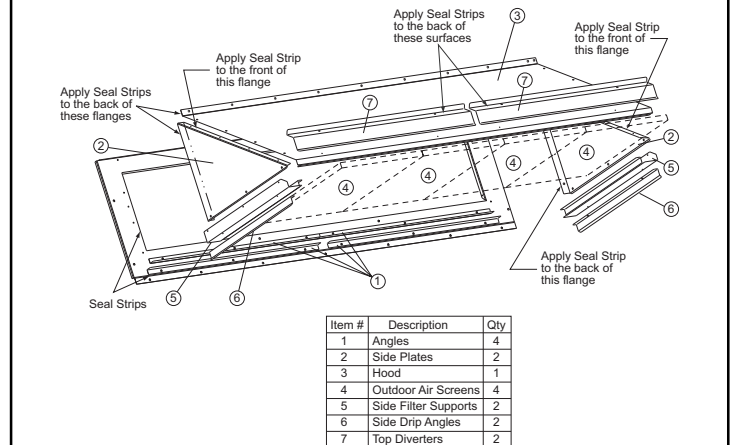

C09079

### To assemble the outside air hood:

1. Remove hood top panel from shipping position on unit end.
2. Install four angles to the upper end panel using the screws provided.
3. Apply seal strip to mating flanges on the side plates of the hood (see FIGURE 13).
4. Secure side plates to panel using the screws provided.
5. Apply seal strip to mating flange of the hood (see FIGURE 13).
6. Secure top flange using screws provided in kit.
7. Install outdoor air screens by sliding them into the channel formed by the four angles installed in step 2. Make sure that the screens extend across the entire length of the hood.

8. Install side filter supports using the screws provided.
9. Install side drip angles using the screws provided.
10. Run a continuous length of seal strip across the hood covering the engagement holes in the lower hood.
11. Install top diverter using the screws provided.
12. On units with barometric relief, remove screws at bottom of relief damper. **Do not discard damper door.**

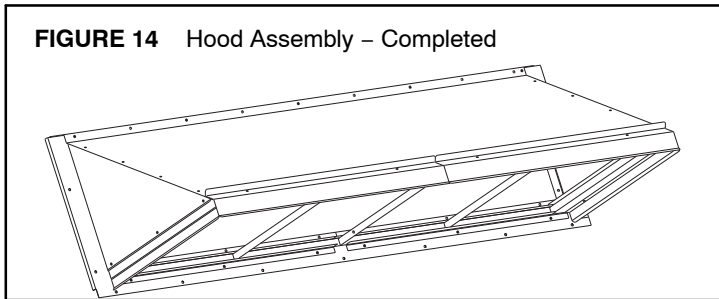

C09090

### Step 8 — Install Flue Hood and Combustion Air Hood

The flue hood is shipped screwed to the fan deck inside the burner compartment. Remove the burner access panel and then remove the flue hood from its shipping location. Using the screws provided, install flue hood in the location shown in Fig. FIGURE 15.

The combustion air hood is attached to the back of the burner access panel. Remove the two screws securing the hood to the back of the burner access panel. Using the two screws, re-attach the hood to the front of the burner access panel as shown in Fig. FIGURE 15.

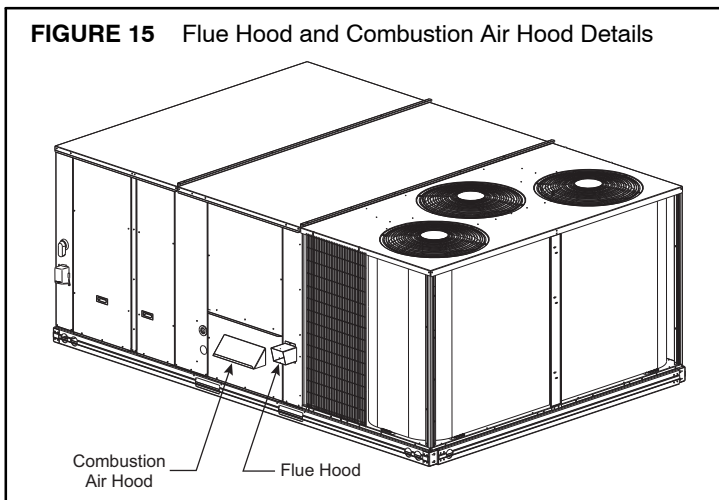

C10744

### Step 9 — Install Gas Piping

Installation of the gas piping must be in accordance with local building codes and with applicable national codes. In U.S.A., refer to NFPA 54/ANSI Z223.1 National Fuel Gas Code (NFGC). In Canada, installation must be accordance with the CAN/CSA B149.1 and CAN/CSA B149.2 installation codes for gas burning appliances.

This unit is factory equipped for use with Natural Gas fuel at elevations up to 2000 ft (610 m) above sea level. Unit may be field converted for operation at elevations above 2000 ft (610 m) and/or for use with liquefied petroleum fuel. See accessory kit installation instructions regarding these accessories.

**NOTE:**Furnace gas input rate on rating plate is for installation up to 2000 ft (610 m) above sea level. In U.S.A. the input rating for altitudes above 2000 ft (610 m) must be derated by 4% for each 1000 ft (305 m) above sea level. In Canada the input rating must be derated by 10% for altitudes of 2000 ft (610 m) to 4500 ft (1372 m) above sea level.

*For natural gas applications, gas pressure at unit gas connection must not be less than 5 in. wg (1246 Pa) or greater than 13 in. wg (3240 Pa) while the unit is operating. For liquified petroleum applications, the gas pressure must not be less than 11 in. wg (2740 Pa) or greater than 13 in. wg (3240 Pa) at the unit connection.*

### Gas Supply Line —

The gas supply pipe enters the unit adjacent to the burner access panel on the front side of the unit, through the grommeted hole. The gas connection to the unit is made to the 3/4 in. FPT gas inlet port on the unit gas valve.

Table 4 lists typical 3/4 inch NPT (National Pipe Thread) field supplied pipe fittings required for Thru-Base gas supply, starting from the unit gas valve (see FIGURE 16).

Pipe gas supply into 90 degree elbow item 15 (see Table 4) through the hole in the unit basepan.

For typical 3/4 inch NPT field supplied fittings required for NON Thru-Base gas supply starting from the unit gas valve, omit items 14 and 15 from Table 4 and pipe gas supply into TEE. see FIGURE 17.

**Table 2—Natural Gas Supply Line Pressure Ranges**

UNIT MODEL	UNIT SIZE	MIN	MAX
RGS	210, 240, 300, 336	5.0 in. wg (1246 Pa)	13.0 in. wg (3240 Pa)

Manifold pressure is factory-adjusted for NG fuel use. Adjust as required to obtain best flame characteristics.

**Table 3—Natural Gas Manifold Pressure Ranges**

UNIT MODEL	UNIT SIZE	HIGH FIRE	LOW FIRE
RGS	210, 240, 300, 336	3.0 in. wg (747 Pa)	2.0 in. Wg (498 Pa)

# ⚠ CAUTION

## EQUIPMENT DAMAGE HAZARD

Failure to follow this caution may result in damage to equipment.

When connecting the gas line to the unit gas valve, the installer **MUST** use a backup wrench to prevent damage to the valve.

**FIGURE 16** Gas Supply Line Piping with Thru-Base

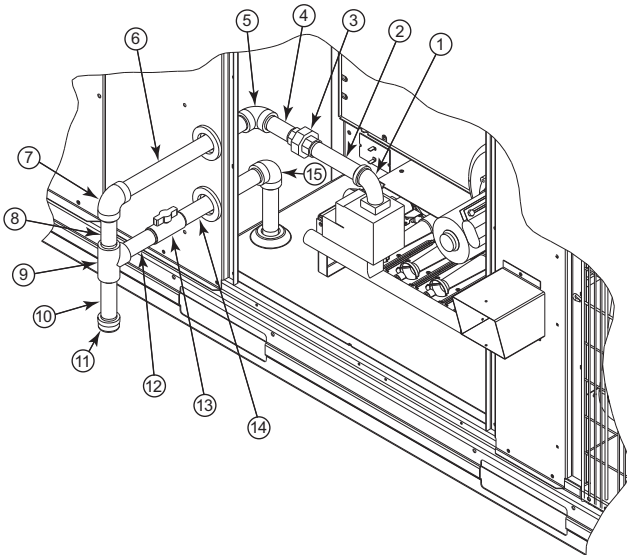

C10999

**FIGURE 17** Gas Supply Line Piping

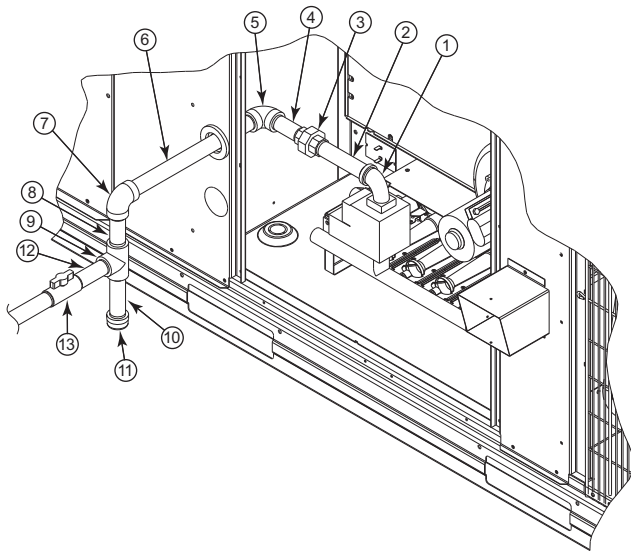

C101006

**Table 4—Typical 3/4-in NPT Field Supplied Piping Parts**

Item	Qty	Description
1	1	90 Deg Street Elbow
2	1	5 Inch Long Nipple
3	1	Ground-Joint Union
4	1	3 Inch Long Nipple
5	1	90 Deg Elbow
6	1	12 Inch Long Nipple
7	1	90 Deg Elbow
8	1	3 Inch Long Nipple
9	1	TEE
10	1	4 Inch Long Nipple (Sediment Trap)
11	1	Cap
12	1	3 1/2 Inch Long Nipple
13	1	NIBCO® Ball Valve, GB30
14	1	8 Inch Long Nipple
15	1	90 Deg Elbow

Install a gas supply line that runs to the unit heating section. Refer to the NFPA 54/NFPA 58 or equivalent code for gas pipe sizing data. Do not use a pipe smaller than the size specified. Size the gas supply line to allow for a maximum pressure drop of 0.5-in wg (124 Pa) between gas regulator source and unit gas valve connection when unit is operating at high-fire flow rate.

The gas supply line can approach the unit in two ways: horizontally from outside the unit (across the roof), or through unit basepan. Observe clearance to gas line components per. FIGURE 18.

**FIGURE 18** Gas Piping Guide

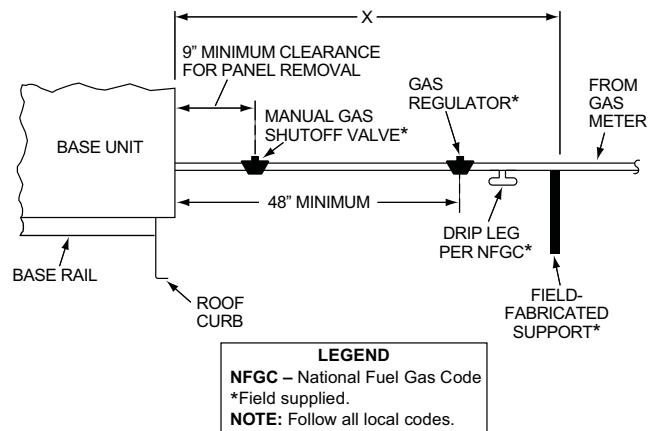

STEEL PIPE NOMINAL DIAMETER (in.)	SPACING OF SUPPORTS X DIMENSION (ft)
1/2	6
3/4 or 1	8
1 1/4 or larger	10

C11121

## Factory-Option Thru-Base Connections —

**Electrical Connections:** Knockouts are located in the control box area. Remove the appropriate size knockout for high voltage connection. Use the field supplied connector depending on wiring or conduit being utilized. Remove the 7/8-in (22mm) knockout and appropriate connector for low voltage wiring. If non-unit powered convenience outlet is being utilized, remove the 7/8-in (22mm) knockout and utilize appropriate connector for 115 volt line. See “Step 11 — Making Electrical Connections” for details.

**Gas Connections:** Remove the knockout in the base pan and route 3/4-in. gas line up through the opening. Install an elbow and route gas line through opening in panel after first removing plastic bushing. Install a gas shut off followed by a drip leg and ground-joint union. Route gas line into gas section through the grommet (Part #: KA56SL112) at the gas inlet and into the gas valve. see FIGURE 16 and Table 4. If a regulator is installed, it must be located 4 feet (1.22 meters) from the flue outlet.

Some municipal codes require that the manual shutoff valve be located upstream of the sediment trap. see FIGURE 17 for typical piping arrangements for gas piping that has been routed through the sidewall of the base pan.

When installing the gas supply line, observe local codes pertaining to gas pipe installations. Refer to the NFPA 54/ANSI Z223.1 NFGC latest edition (in Canada, CAN/CSA B149.1). In the absence of local building codes, adhere to the following pertinent recommendations:

1. Avoid low spots in long runs of pipe. Grade all pipe 1/4-in. in every 15 ft (7 mm in every 5 m) to prevent traps. Grade all horizontal runs downward to risers. Use risers to connect to heating section and to meter.
2. Protect all segments of piping system against physical and thermal damage. Support all piping with appropriate straps, hangers, etc. Use a minimum of one hanger every 6 ft (1.8 m). For pipe sizes larger than 1/2-in., follow recommendations of national codes.
3. Apply joint compound (pipe dope) sparingly and only to male threads of joint when making pipe connections. Use only pipe dope that is resistant to action of liquefied petroleum gases as specified by local and/or national codes. If using PTFE (Teflon) tape, ensure the material is Double Density type and is labeled for use on gas lines. Apply tape per manufacturer's instructions.
4. Pressure-test all gas piping in accordance with local and national plumbing and gas codes before connecting piping to unit.

**NOTE:** Pressure test the gas supply system after the gas supply piping is connected to the gas valve. The supply piping must be disconnected from the gas valve during the testing of the piping systems when test pressure is in excess of 0.5 psig (3450 Pa). Pressure test the gas supply piping system at pressures equal to or less than 0.5 psig (3450 Pa). The unit heating section must be isolated from the gas piping system by closing the external main manual shutoff valve and slightly opening the ground-joint union.

Check for gas leaks at the field-installed and factory-installed gas lines after all piping connections have been completed. Use soap-and-water solution (or method specified by local codes and/or regulations).

## ⚠ WARNING

### FIRE OR EXPLOSION HAZARD

Failure to follow this warning could result in personal injury, death and/or property damage.

- Connect gas pipe to unit using a backup wrench to avoid damaging gas controls.
- Never purge a gas line into a combustion chamber.
- Never test for gas leaks with an open flame. Use a commercially available soap solution made specifically for the detection of leaks to check all connections.
- Use proper length of pipe to avoid stress on gas control manifold.

**NOTE:** If orifice hole appears damaged or it is suspected to have been redrilled, check orifice hole with a numbered drill bit of correct size. Never redrill an orifice. A burr-free and squarely aligned orifice hole is essential for proper flame characteristics.

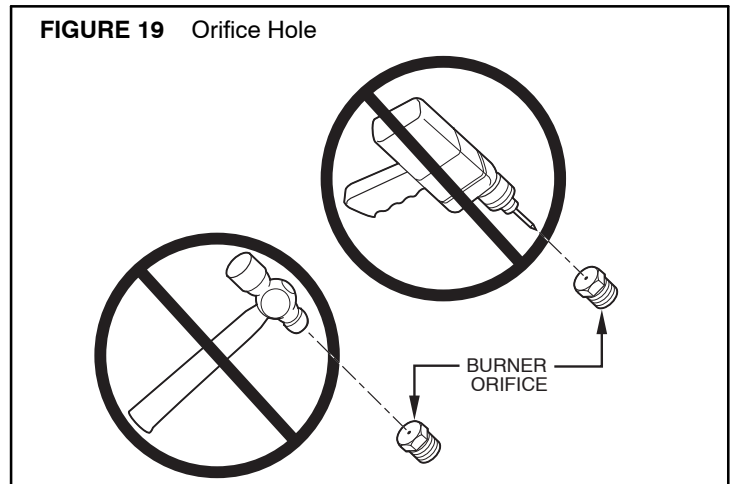

A93059

## Step 10 — Install External Condensate Trap & Line

The unit has one  $\frac{3}{4}$ -in. condensate drain connection on the end of the condensate pan (see FIGURE 20). See FIGURE 1, FIGURE 2 and FIGURE 3, item “E”, in the view labeled “BACK” for the location of the condensate drain connection.

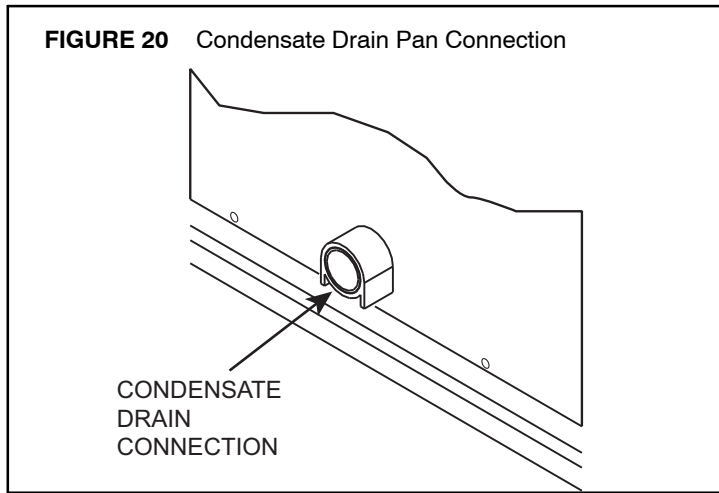

C10729

The piping for the condensate drain and external trap can be completed after the unit is in place. Hand tighten fittings to the drain pan fitting. Provide adequate support for the drain line. Failure to do so can result in damage to the drain pan. see FIGURE 21.

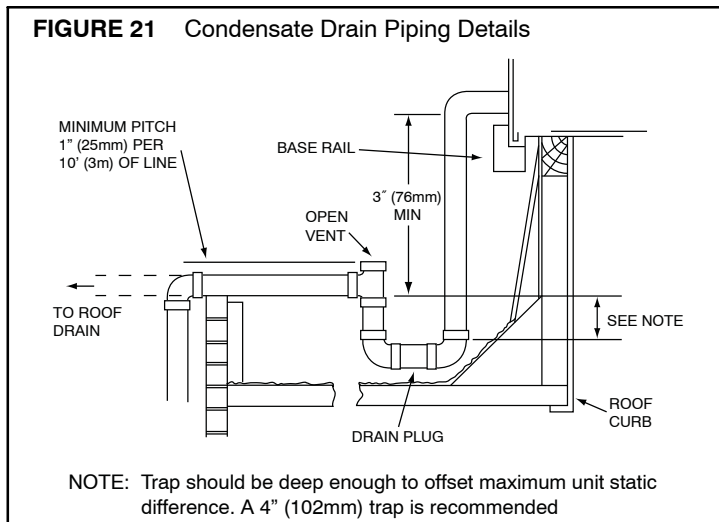

C11291

All units must have an external trap for condensate drainage. Install a trap at least 4-in. (102 mm) deep and protect against freeze-up. If drain line is installed downstream from the external trap, pitch the line away from the unit at 1-in. per 10 ft (25 mm in 3 m) of run. Do not use a pipe size smaller than the unit connection ( $\frac{3}{4}$ -in.).

## Step 11 — Make Electrical Connections

### **⚠ WARNING**

#### **ELECTRICAL SHOCK HAZARD**

Failure to follow this warning could result in personal injury or death.

*Do not use gas piping as an electrical ground.* Unit cabinet must have an uninterrupted, unbroken electrical ground to minimize the possibility of personal injury if an electrical fault should occur. This ground may consist of electrical wire connected to unit ground lug in control compartment, or conduit approved for electrical ground when installed in accordance with NEC (National Electrical Code); ANSI/NFPA 70, latest edition (in Canada, Canadian Electrical Code CSA [Canadian Standards Association] C22.1), and local electrical codes.

**NOTE:**Field-supplied wiring shall conform with the limitations of minimum 63°F (33°C) rise.

#### **Field Power Supply —**

On a unit without a unit-mounted disconnect, connect the source leads to the line side with unit field power leads. see FIGURE 22.

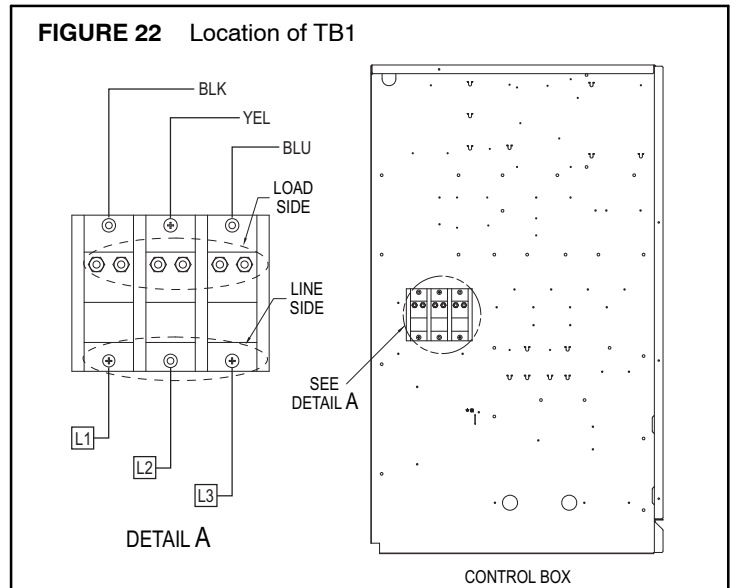

C11181

Field power wires are connected to the unit at line-side pressure lugs on the terminal block (see wiring diagram label for control box component arrangement) or at factory-installed option non-fused disconnect switch. Use copper conductors only.

**NOTE:**Make field power connections directly to line connection pressure lugs only.

# ⚠ WARNING

## FIRE HAZARD

Failure to follow this warning could result in intermittent operation or unsatisfactory performance.

Do not connect aluminum wire between disconnect switch and air conditioning unit. Use only copper wire. (see FIGURE 23.)

**FIGURE 23** Disconnect Switch and Unit

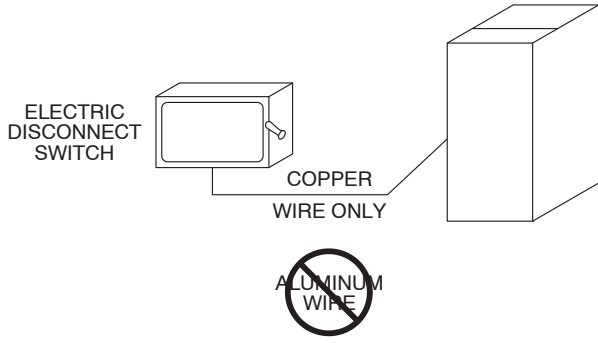

A93033

## Units Without Factory-Installed Non-Fused Disconnect —

When installing units, provide a disconnect switch per NEC (National Electrical Code) of adequate size. Disconnect sizing data is provided on the unit informative plate. Locate on unit cabinet or within sight of the unit per national or local codes. Do not cover unit informative plate if mounting the disconnect on the unit cabinet.

## Units With Factory-Installed Non-Fused Disconnect —

The factory-installed option non-fused disconnect switch (NFD) is located in the main control box. The manual switch handle and shaft are shipped in the control box and must be mounted on the corner post adjacent to the control box (see FIGURE 24). Note that the tape covering the hole for the shaft in the corner post must be removed prior to handle and shaft installation.

### To field install the NFD shaft and handle:

1. Open the control box panel.
2. Make sure the NFD shipped from the factory is at OFF position (the arrow on the black handle knob or on the silver metal collar is at OFF).
3. Insert the shaft with the cross pin on the top of the shaft in the horizontal position.
4. Measure the tip of the shaft to the outside surface of the corner post to be 0.88".
5. Tighten the locking screw to secure the shaft to the NFD.
6. Turn the handle to OFF position with red arrow pointing at OFF.
7. Install the handle on to the corner post vertically with the red arrow pointing up.

8. Secure the handle to the corner post with (2) screws and lock washers supplied.

**FIGURE 24** Handle and Shaft Assembly for NFD

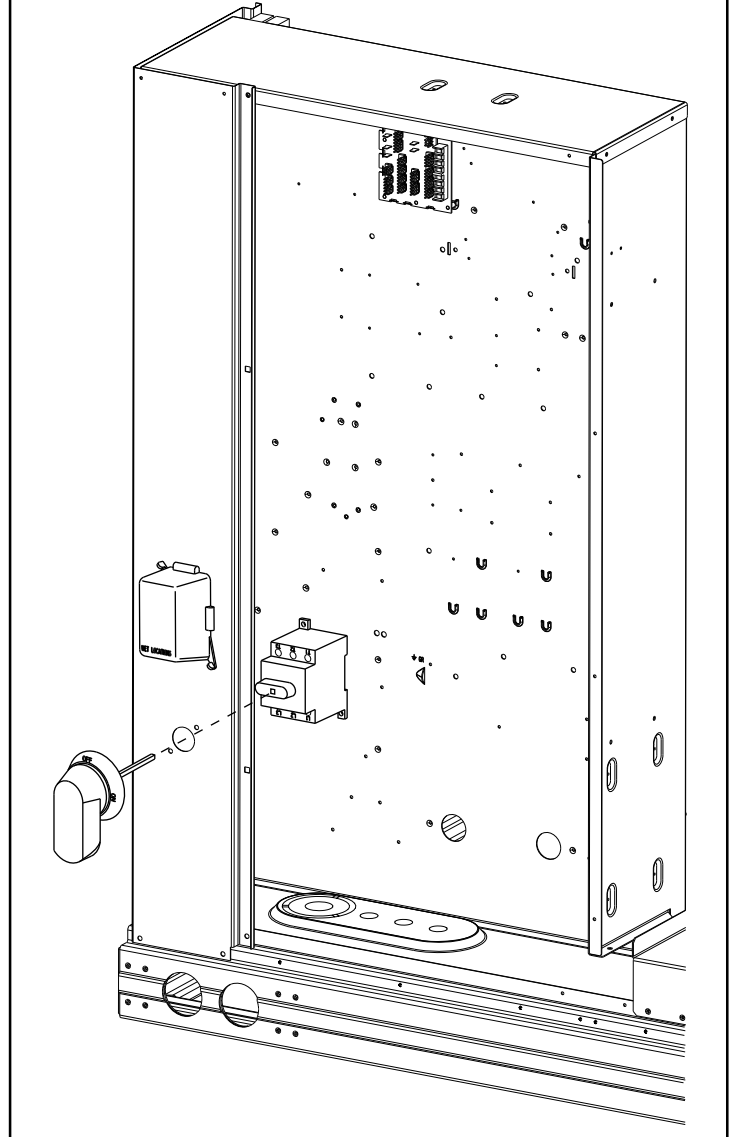

C12385

## All Units -

All field wiring must comply with NEC and all local code requirements.

Size wire based on MCA (Minimum Circuit Amps) on the unit informative plate. see FIGURE 25 for power wiring connections to the unit power terminal block and equipment ground. Maximum wire size is 2/0 AWG per pole.

Provide a ground-fault and short-circuit over-current protection device (fuse or breaker) per NEC Article 440 (or local codes). Refer to unit informative data plate for MOCP (Maximum Over-current Protection) device size.

Voltage to compressor terminals during operation must be within voltage range indicated on unit nameplate. See Table 5. On 3-phase units, voltages between phases must be balanced within 2% and the current within 10%. Use the

formula shown in the legend for Tables 5, 6, 7. (see Note 2 on page 28) to determine the percent of voltage imbalance.

hinged access cover, located on the corner panel of the unit. see FIGURE 26.

## ⚠ CAUTION

### UNIT DAMAGE HAZARD

Failure to follow this caution may result in equipment damage.

Operation on improper line voltage or excessive phase imbalance constitutes abuse and may cause damage to electrical components. Such operation would invalidate any applicable Carrier warranty.

**FIGURE 26** Convenience Outlet Location

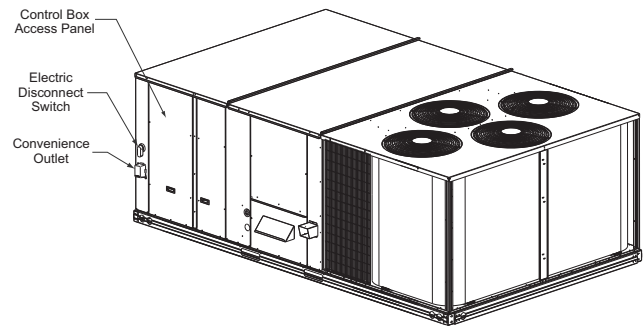

C10641

**FIGURE 25** Power Wiring Connections

Units Without Disconnect Option

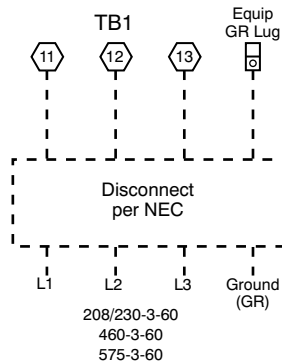

Units With Disconnect Option

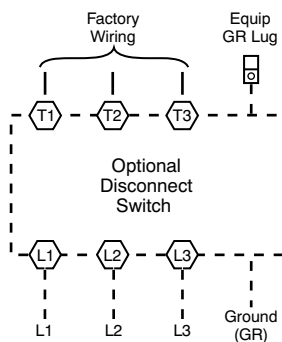

**Installing Weatherproof Cover:** A weatherproof while-in-use cover for the factory-installed convenience outlets is now required by UL standards. This cover cannot be factory-mounted due to its depth; it must be installed at unit installation. For shipment, the convenience outlet is covered with a blank cover plate.

The weatherproof cover kit is shipped in the unit's control box. The kit includes the hinged cover, a backing plate and gasket.

**DISCONNECT ALL POWER TO UNIT AND CONVENIENCE OUTLET. LOCK-OUT AND TAG-OUT ALL POWER.**

Remove the blank cover plate at the convenience outlet; discard the blank cover.

Loosen the two screws at the GFCI duplex outlet, until approximately 1/2-in (13 mm) under screw heads are exposed. Press the gasket over the screw heads. Slip the backing plate over the screw heads at the keyhole slots and align with the gasket; tighten the two screws until snug (do not over-tighten).

Mount the weatherproof cover to the backing plate as shown in Fig. FIGURE 27. Remove two slot fillers in the bottom of the cover to permit service tool cords to exit the cover. Check for full closing and latching.

C13662

### Convenience Outlets —

## ⚠ WARNING

### ELECTRICAL OPERATION HAZARD

Failure to follow this warning could result in personal injury or death.

Units with convenience outlet circuits may use multiple disconnects. Check convenience outlet for power status before opening unit for service. Locate its disconnect switch, if appropriate, and open it. Lock-out and tag-out this switch, if necessary.

Non-powered convenience outlets are offered on RGS models which provide a 125-volt GFCI (ground-fault circuit-interrupter) duplex receptacle rated at 15-A behind a

**FIGURE 27** Weatherproof Cover Installation

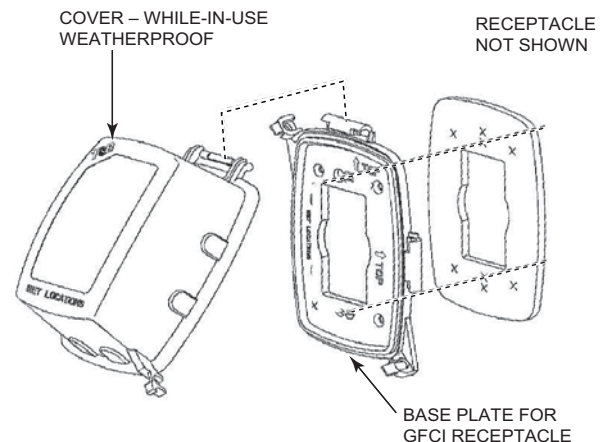

C09022

**Non-unit powered type:** This type requires the field installation of a general-purpose 125-volt 15-A circuit powered from a source elsewhere in the building. Observe national and local codes when selecting wire size, fuse or breaker requirements and disconnect switch size and location. Route 125-v power supply conductors into the bottom of the utility box containing the duplex receptacle.

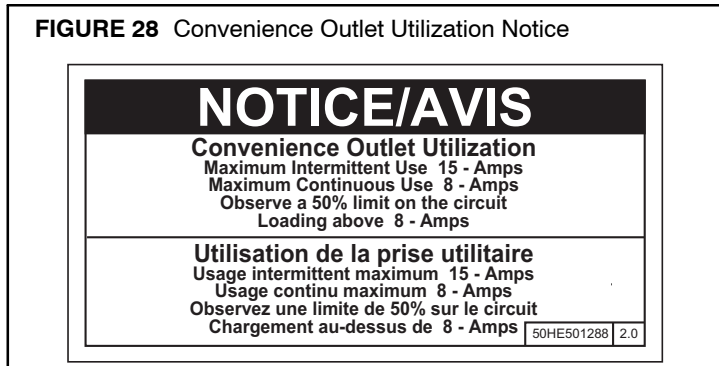

C10077

Test the GFCI receptacle by pressing the TEST button on the face of the receptacle to trip and open the receptacle. Check for proper grounding wires and power line phasing if the GFCI receptacle does not trip as required. Press the RESET button to clear the tripped condition.

Using unit-mounted convenience outlets: Units with unit-mounted convenience outlet circuits will often require that two disconnects be opened to de-energize all power to the unit. Treat all units as electrically energized until the convenience outlet power is also checked and de-energization is confirmed. Observe National Electrical Code Article 210, Branch Circuits, for use of convenience outlets.

#### Factory-Option Thru-Base Connections —

All units are equipped with the ability to bring utilities through the base.

Gas is brought up through an embossed area located in the gas section behind the gas entrance post. Access is gained through the gas access panel. A knock out must be removed to accomplish this.

The electrical entrance is located in the control box area and can be accessed through the control box access panel. An embossed area is provided with three knock outs. High voltage is brought through the multi knock out by removing the appropriate size for the size of the fitting required. A 7/8-in. knock out is provided for low voltage. An additional 7/8-in. knock out is provided for a 115 volt line which is used

when the unit is equipped with the non-unit powered convenience outlet option.

All required fittings are field supplied. Install fittings when access to both top and bottom of the base pan is available. See electrical and gas connections for routing and connection information.

#### Units Without Thru-Base Connections —

1. Install liquid tight conduit between disconnect and control box.
2. Pull correctly rated high voltage wires through the conduit.
3. Install power lines to terminal connections as shown in Fig. FIGURE 25.

#### Field Control Wiring —

The RGS unit requires an external temperature control device. This device can be a thermostat (field-supplied)

#### Thermostat —

Install a an approved accessory 2-stage thermostat according to installation instructions included with the accessory. Locate the thermostat accessory on a solid wall in the conditioned space to sense average temperature in accordance with the thermostat installation instructions.

If the thermostat contains a logic circuit requiring 24-v power, use a thermostat cable or equivalent single leads of different colors with minimum of seven leads. If the thermostat does not require a 24-v source (no "C" connection required), use a thermostat cable or equivalent with minimum of six leads. Check the thermostat installation instructions for additional features which might require additional conductors in the cable.

For wire runs up to 50 ft. (15 m), use no. 18 AWG (American Wire Gage) insulated wire (35°C minimum). For 50 to 75 ft. (15 to 23 m), use no. 16 AWG insulated wire (35°C minimum). For over 75 ft. (23 m), use no. 14 AWG insulated wire (35°C minimum). All wire sizes larger than no. 18 AWG cannot be directly connected to the thermostat and will require a junction box and splice at the thermostat.

#### Unit Without Thru-Base Connection Kit —

Correctly rated low voltage wire can be routed through the rubber grommet located on the corner post adjacent to the control box access panel. Route wire through the grommet and then route the wire behind the corner post utilizing the factory provided wire ties secured to the control box. This will insure separation of the field low voltage wire and the high

voltage circuit. Route the low voltage wire to the central terminal board. see FIGURE 29.

## Hot Gas Reheat Control Connections

### Hot Gas Reheat – Space RH Controller —

**NOTE:**The Hot Gas Reheat is a factory installed option which is only available for size 17.5, 20, 25, and 27.5 ton units equipped with RTPF condenser coils.

The Hot Gas Reheat dehumidification system requires a field-supplied and -installed space relative humidity control device. This device may be a separate humidistat control (contact closes on rise in space RH above control setpoint) or a combination thermostat-humidistat control device.

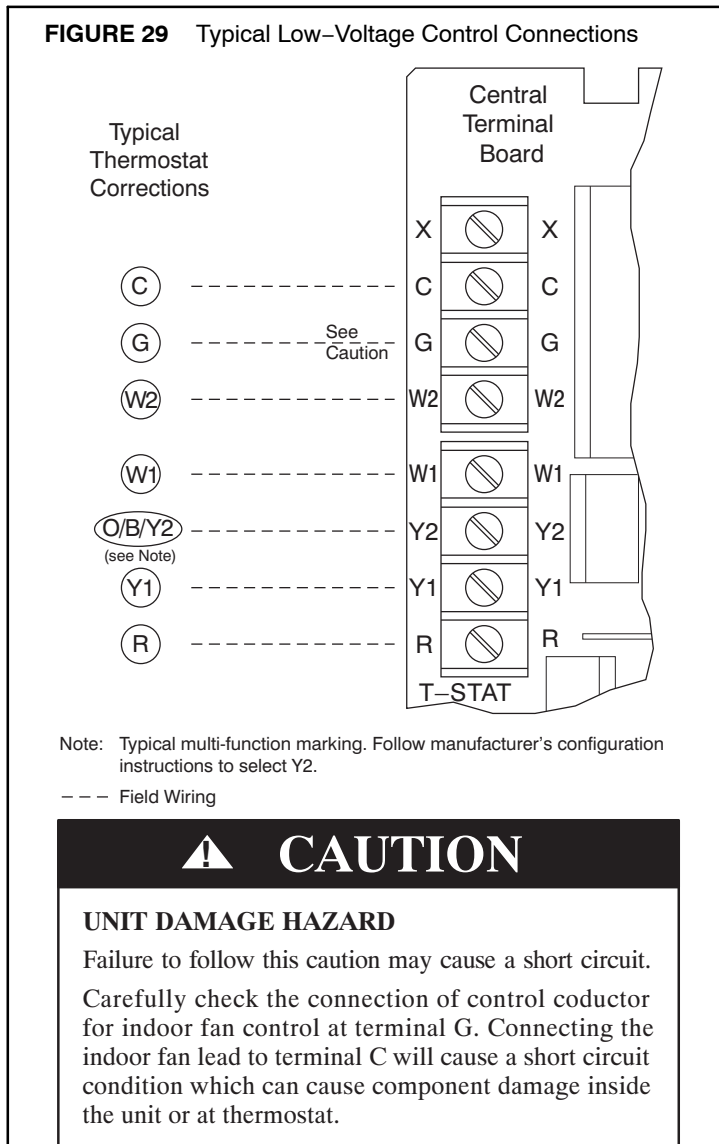

C10731

**NOTE:**If utilizing the through the base connections, route the low voltage wire through the wire ties to the central terminal board.

### Heat Anticipator Settings —

Set heat anticipator settings at 0.14 amp for the first stage and 0.14 amp for second-stage heating.

### Transformer Connection for 208-v Power Supply —

All units except 208/230-v units are factory wired for the voltage shown on the nameplate. *If the 208/230-v unit is to be connected to a 208-v power supply, the control transformer must be rewired by moving the black wire with the 1/4-in. female spade connector from the 230-v connection and moving it to the 208-v 1/4-in. male terminal on the primary side of the transformer.* Refer to unit label diagram for additional information.

**FIGURE 30** Typical Hot Gas Reheat Adaptive Dehumidification System Humidistat Wiring

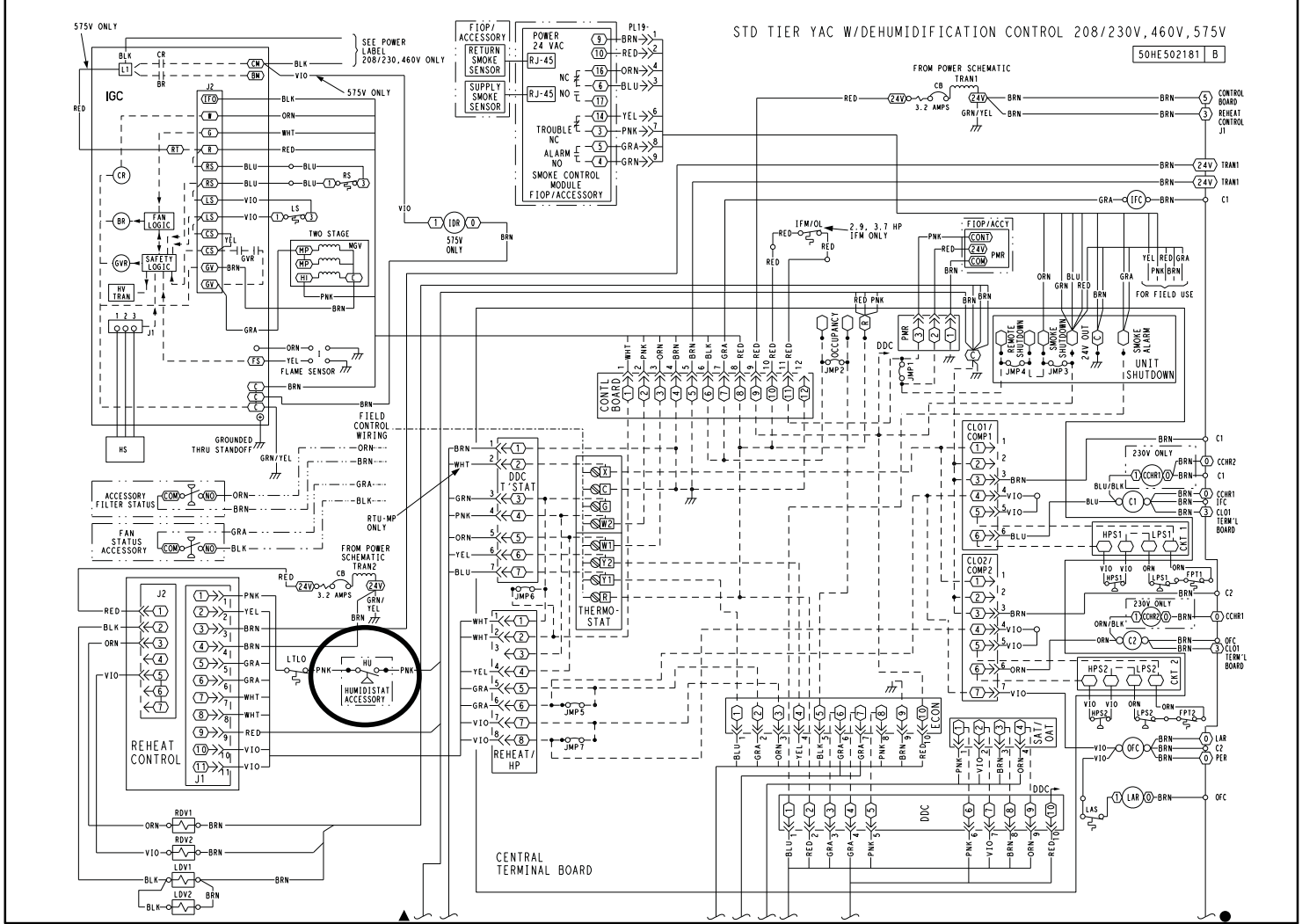

**2-Speed with Variable Frequency Drive (Factory Option)**

For details on operating RGS 2 stage cooling units equipped with the factory installed 2 speed with VFD Drive option, refer to the *Variable Frequency Drive (VFD) installation, Setup & Troubleshooting Supplement* (51306290200, or later).

**Smoke Detectors**

Smoke detectors are available as factory-installed options on RGS models. Smoke detectors may be specified for Supply Air only or for Return Air without or with economizer or in combination of Supply Air and Return Air. Return Air smoke detectors are arranged for vertical return configurations only. The unit is factory-configured for immediate smoke detector shutdown operation; additional wiring or modifications to unit terminal board may be necessary to complete the unit and smoke detector configuration to meet project requirements.

**Return Air Sensor Tube Installation —**

The return air sampling tube is shipped in the unit's supply fan section, attached to the blower housing (see

**FIGURE 31**. Its operating location is in the return air section of the unit (see FIGURE 32, unit without economizer, or Fig. FIGURE 33, unit with economizer), inserted into the return air sensor module housing which protrudes through the back of the control box.

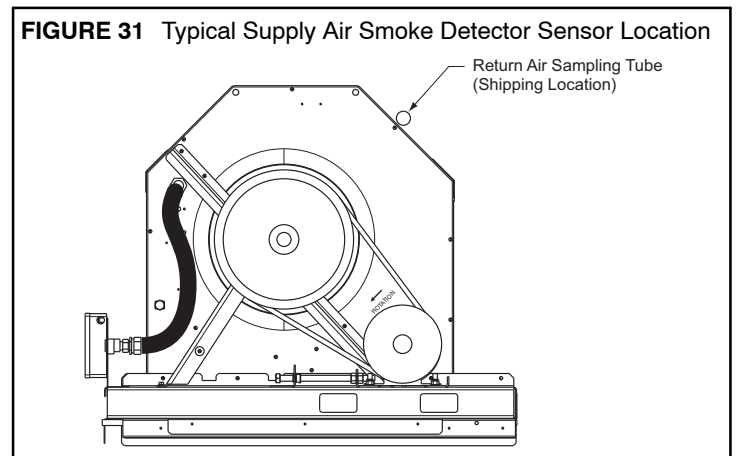

C11126

C09102

**FIGURE 32** Return Air Sampling Tube Location in Unit without Economizer

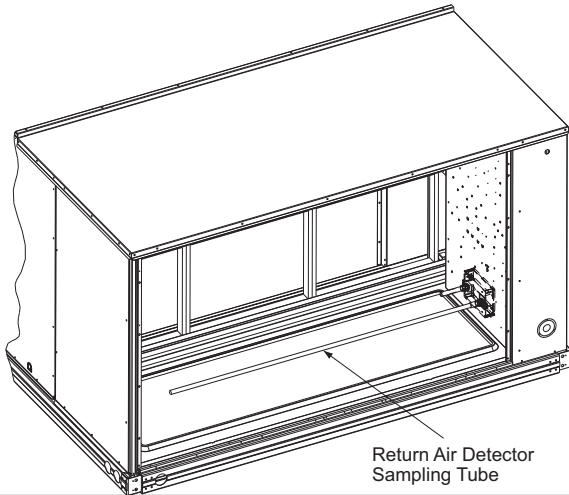

C09135

**To install the return air sensor sampling tube:**

1. Remove the tube from its shipping location.
2. Open the unit end to access the return air sensor (located on right-hand partition)
3. Orient the tube's sampling holes into the return air flow direction. For vertical application, position the sampling holes on the bottom of the tube, facing into the bottom return duct opening.
4. Insert the sampling tube into the return air sensor module until the tube snaps into position.
5. Replace end panel or outside air hood.

**Smoke Detector Test Magnet —**

Locate the magnet; it is shipped in the control box area.

**FIGURE 33** Return Air Sampling Tube Location in Unit with Economizer

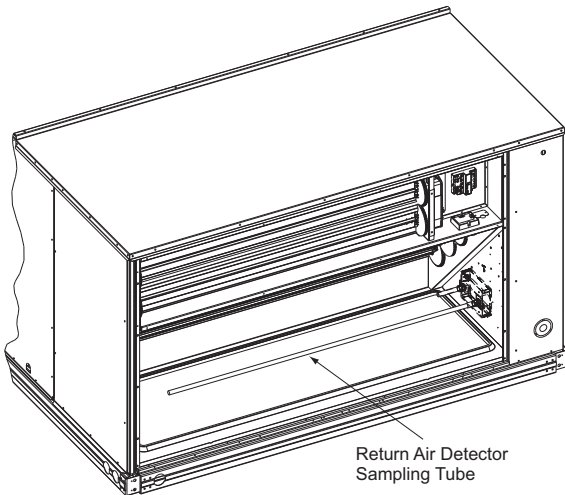

C09136

# ELECTRICAL DATA FOR UNITS PRODUCED ON OR AFTER JULY 30, 2012

**NOTE:** Check the serial number of unit to verify production date.

To confirm the date of manufacture, locate the unit nameplate and check the first four digits of the Serial Number. If the number listed in the first 4 digits of the Serial Number is 3112 or higher, the unit was produced on or after July 30, 2012.

Position:	1	2	3	4	5	6	7	8	9	10
Example:	3	1	1	2	U	1	2	3	4	5

Week of manufacture (fiscal calendar)		Sequence number
Year of manufacture ("12" = 2012)		Manufacturing location

C12562A

## Legend and Notes for Tables 5, 6 and 7

**LEGEND:**

- BRKR – Circuit breaker
- CO – Convenience outlet
- DISC – Disconnect
- FLA – Full load amps
- LRA – Locked rotor amps
- MCA – Minimum circuit amps
- PE – Power exhaust
- PWRD CO – Powered convenient outlet
- UNPWR CO – Unpowered convenient outlet



**NOTES:**

1. In compliance with NEC requirements for multimotor and combination load equipment (refer to NEC Articles 430 and 440), the overcurrent protective device for the unit shall be fuse or HACR breaker. Canadian units may be fuse or circuit breaker.

**2. Unbalanced 3-Phase Supply Voltage**

Never operate a motor where a phase imbalance in supply voltage is greater than 2%. Use the following formula to determine the percentage of voltage imbalance.

$$\% \text{ Voltage Imbalance} = 100 \times \frac{\text{max voltage deviation from average voltage}}{\text{average voltage}}$$

Example: Supply voltage is 230-3-60



- AB = 224 v
- BC = 231 v
- AC = 226 v

$$\begin{aligned} \text{Average Voltage} &= \frac{(224 + 231 + 226)}{3} = \frac{681}{3} \\ &= 227 \end{aligned}$$

Determine maximum deviation from average voltage.

- (AB) 227 – 224 = 3 v
- (BC) 231 – 227 = 4 v
- (AC) 227 – 226 = 1 v

Maximum deviation is 4 v.

Determine percent of voltage imbalance.

$$\begin{aligned} \% \text{ Voltage Imbalance} &= 100 \times \frac{4}{227} \\ &= 1.76\% \end{aligned}$$

This amount of phase imbalance is satisfactory as it is below the maximum allowable 2%.

**IMPORTANT:** If the supply voltage phase imbalance is more than 2%, contact your local electric utility company immediately.

**Table 5— Unit Wire/Fuse or HACR Breaker Sizing Data**

UNIT	NOM. V–Ph–Hz	IFM TYPE	NO C.O. or UNPWR C.O.							
			NO PE.				w/ PE. (pwrd fr/ unit)			
			MCA	MAX FUSE or HACR BRKR	DISC. SIZE		MCA	MAX FUSE or HACR BRKR	DISC. SIZE	
					FLA	LRA			FLA	LRA
RGS210	208/230–3–60	STD	82.2	100	86	515	94.0	110	99	535
		MED	85.2/84.3	100/100	89/88	517	97.0/96.1	125/125	103/102	537
		HIGH	88.7	100	93	513	100.5	125	107	533
	460–3–60	STD	43.6	60	45	258	49.8	60	52	270
		MED	44.7	60	47	259	50.9	60	54	271
		HIGH	46.9	60	49	257	53.1	60	56	269
	575–3–60	STD	32.1	40	33	188	36.9	45	39	196
		MED	34.9	45	37	202	39.7	50	42	210
		HIGH	36.9	45	39	200	41.7	50	44	208
RGS240	208/230–3–60	STD	109.2/108.3	150/150	112/111	540	121.0/120.1	150/150	125/124	560
		MED	112.7	150	116	536	124.5	150	129	556
		HIGH	124.1	150	129	615	135.9	175	142	635
	460–3–60	STD	48.0	60	50	272	54.2	60	57	284
		MED	50.2	60	52	270	56.4	70	59	282
		HIGH	55.9	70	59	310	62.1	80	66	322
	575–3–60	STD	38.6	50	40	224	43.4	50	46	232
		MED	40.6	50	42	222	45.4	60	48	230
		HIGH	42.5	50	45	249	47.3	60	50	257
RGS300	208/230–3–60	STD	127.8/126.9	175/175	133/132	590	139.6/138.7	175/175	147/146	610
		MED	131.3	175	137	586	143.1	175	151	606
		HIGH	142.7	175	150	665	154.5	200	164	685
	460–3–60	STD	51.9	60	54	302	58.1	70	61	314
		MED	54.1	60	57	300	60.3	70	64	312
		HIGH	59.8	70	63	340	66.0	80	70	352
	575–3–60	STD	41.1	50	43	244	45.9	60	49	252
		MED	43.1	50	45	242	47.9	60	51	250
		HIGH	45.0	50	47	269	49.8	60	53	277
RGS336	208/230–3–60	STD	141.5	175	148	702	153.3	200	162	722
		MED	152.9	200	161	781	164.7	200	175	801
		HIGH	154.8	200	163	812	166.6	200	177	832
	460–3–60	STD	66.0	80	69	354	72.2	90	76	366
		MED	71.7	90	76	394	77.9	100	83	406
		HIGH	72.6	90	77	409	78.8	100	84	421
	575–3–60	STD	56.0	70	59	264	60.8	80	64	272
		MED	57.9	70	61	291	62.7	80	66	299
		HIGH	60.8	80	64	302	65.6	80	70	310

See: ""Legend and Notes for Tables 5, 6, & 7 on page 28.

**Table 6— Unit Wire/Fuse or HACR Breaker Sizing Data with Factory Installed 2 Speed Indoor Fan Option**

UNIT	NOM. V-Ph-Hz	IFM TYPE	NO C.O. or UNPWR C.O.							
			NO P.E.				w/ P.E. (pwrd fr/ unit)			
			MCA	MAX FUSE or HACR BRKR	DISC. SIZE		MCA	MAX FUSE or HACR BRKR	DISC. SIZE	
					FLA	LRA			FLA	LRA
RGS210	208/230-3-60	STD	82.4/81.4	100/100	86/85	506	94.2/93.2	110/110	100/99	526
		MED	85.2/84.3	100/100	89/88	517	97.0/96.1	125/125	103/102	537
		HIGH	88.7	100	93	513	100.5	125	107	533
	460-3-60	STD	43.2	50	45	254	49.4	60	52	266
		MED	44.7	60	47	259	50.9	60	54	271
		HIGH	46.9	60	49	257	53.1	60	56	269
	575-3-60	STD	33.8	45	35	188	38.6	50	41	196
		MED	35.5	45	37	202	40.3	50	43	210
		HIGH	36.9	45	39	200	41.7	50	44	208
RGS240	208/230-3-60	STD	109.2/108.3	150/150	112/111	540	121.0/120.1	150/150	125/124	560
		MED	112.7	150	116	536	124.5	150	129	556
		HIGH	124.1	150	129	615	135.9	175	142	635
	460-3-60	STD	48.0	60	50	272	54.2	60	57	284
		MED	50.2	60	52	270	56.4	70	59	282
		HIGH	55.9	70	59	310	62.1	80	66	322
	575-3-60	STD	39.2	50	41	224	44.0	50	46	232
		MED	40.6	50	42	222	45.4	60	48	230
		HIGH	42.5	50	45	249	47.3	60	50	257
RGS300	208/230-3-60	STD	127.8/126.9	175/175	133/132	590	139.6/138.7	175/175	147/146	610
		MED	131.3	175	137	586	143.1	175	151	606
		HIGH	142.7	175	150	665	154.5	200	164	685
	460-3-60	STD	51.9	60	54	302	58.1	70	61	314
		MED	54.1	60	57	300	60.3	70	64	312
		HIGH	59.8	70	63	340	66.0	80	70	352
	575-3-60	STD	41.7	50	44	244	46.5	60	49	252
		MED	43.1	50	45	242	47.9	60	51	250
		HIGH	45	50	47	269	49.8	60	53	277
RGS336	208/230-3-60	STD	141.5	175	148	702	153.3	200	162	722
		MED	152.9	200	161	781	164.7	200	175	801
		HIGH	154.8	200	163	812	166.6	200	177	832
	460-3-60	STD	66.0	80	69	354	72.2	90	76	366
		MED	71.7	90	76	394	77.9	100	83	406
		HIGH	72.6	90	77	409	78.8	100	84	421
	575-3-60	STD	56.0	70	59	264	60.8	80	64	272
		MED	57.9	70	61	291	62.7	80	66	299
		HIGH	60.8	80	64	302	65.6	80	70	310

See: ""Legend and Notes for Tables 5, 6, & 7 on page 28.

# ELECTRICAL DATA FOR UNITS PRODUCED PRIOR TO JULY 30, 2012

**NOTE:** Check the serial number of unit to verify production date.

## SERIAL NUMBER

1	2	3	4	5	6	7	8	9	10
U	1	2	3	1	1	2	3	4	5

Manufacture Location

Week of Manufacture  
(fiscal calendar)

Sequence Number

Year of Manufacture  
(12 = 2012)

**Table 7— Unit Wire/Fuse or HACR Breaker Sizing Data**

UNIT	NOM. V-Ph-Hz	IFM TYPE	COMBUSTION FAN MOTOR FLA	POWER EXHAUST FLA	NO C.O. or UNPWR C.O.							
					NO P.E.				w/ P.E. (pwrd fr/ unit)			
					MCA	FUSE or HACR BRKR	DISC. SIZE		MCA	FUSE or HACR BRKR	DISC. SIZE	
							FLA	LRA			FLA	LRA
RGS210	208/230-3-60	STD	0.52	5.9	81.8	100.0	85	502	93.6	110.0	99	522
		MED			86.6	100.0	91	511	98.4	125.0	105	531
		HIGH			92.0	100.0	97	521	103.8	125.0	111	541
	460-3-60	STD	0.3	3.1	43.1	50.0	45	252	49.3	60.0	52	264
		MED			45.7	60.0	48	256	51.9	60.0	55	268
		HIGH			48.5	60.0	51	261	54.7	60.0	58	273
	575-3-60	STD	0.24	2.4	32.1	40.0	33	188	36.9	45.0	39	196
		MED			34.9	45.0	37	202	39.7	50.0	42	210
		HIGH			38.3	50.0	40	200	43.1	50.0	46	208
RGS240	208/230-3-60	STD	0.52	5.9	110.6	150.0	113	534	122.4	150.0	127	554
		MED			116.0	150.0	120	544	127.8	175.0	133	564
		HIGH			128.7	175.0	134	618	140.5	175.0	148	638
	460-3-60	STD	0.3	3.1	49.0	60.0	51	269	55.2	60.0	58	281
		MED			51.8	60.0	54	274	58.0	70.0	61	286
		HIGH			57.8	70.0	61	311	64.0	80.0	68	323
	575-3-60	STD	0.24	2.4	38.6	50.0	40	224	43.4	50.0	46	232
		MED			42.0	50.0	44	222	46.8	60.0	50	230
		HIGH			42.5	50.0	45	249	47.3	60.0	50	257
RGS300	208/230-3-60	STD	0.52	5.9	129.2	175.0	135	584	141.0	175.0	148	604
		MED			134.6	175.0	141	594	146.4	175.0	155	614
		HIGH			147.3	175.0	156	668	159.1	200.0	169	688
	460-3-60	STD	0.3	3.1	52.9	60.0	55	299	59.1	70.0	63	311
		MED			55.7	70.0	59	304	61.9	80.0	66	316
		HIGH			61.7	80.0	66	341	67.9	80.0	73	353
	575-3-60	STD	0.24	2.4	41.1	50.0	43	244	45.9	60.0	49	252
		MED			44.5	50.0	47	242	49.3	60.0	52	250
		HIGH			45.0	50.0	47	269	49.8	60.0	53	277
RGS336	208/230-3-60	STD	0.52	5.9	137.2	175.0	143	702	149.0	200.0	157	722
		MED			157.5	200.0	166	784	169.3	200.0	180	804
		HIGH			160.1	200.0	169	824	171.9	200.0	183	844
	460-3-60	STD	0.3	3.1	63.8	80.0	67	354	70.0	90.0	74	366
		MED			73.6	90.0	78	395	79.8	100.0	85	407
		HIGH			74.7	90.0	79	415	80.9	100.0	86	427
	575-3-60	STD	0.24	2.4	53.5	60.0	56	255	58.3	70.0	61	263
		MED			57.9	70.0	61	291	62.7	80.0	66	299
		HIGH			62.9	80.0	67	302	67.7	80.0	72	310

See: ""Legend and Notes for Tables 5, 6, & 7 on page 28.

**FIGURE 34**

**Field Control Wiring Raceway**

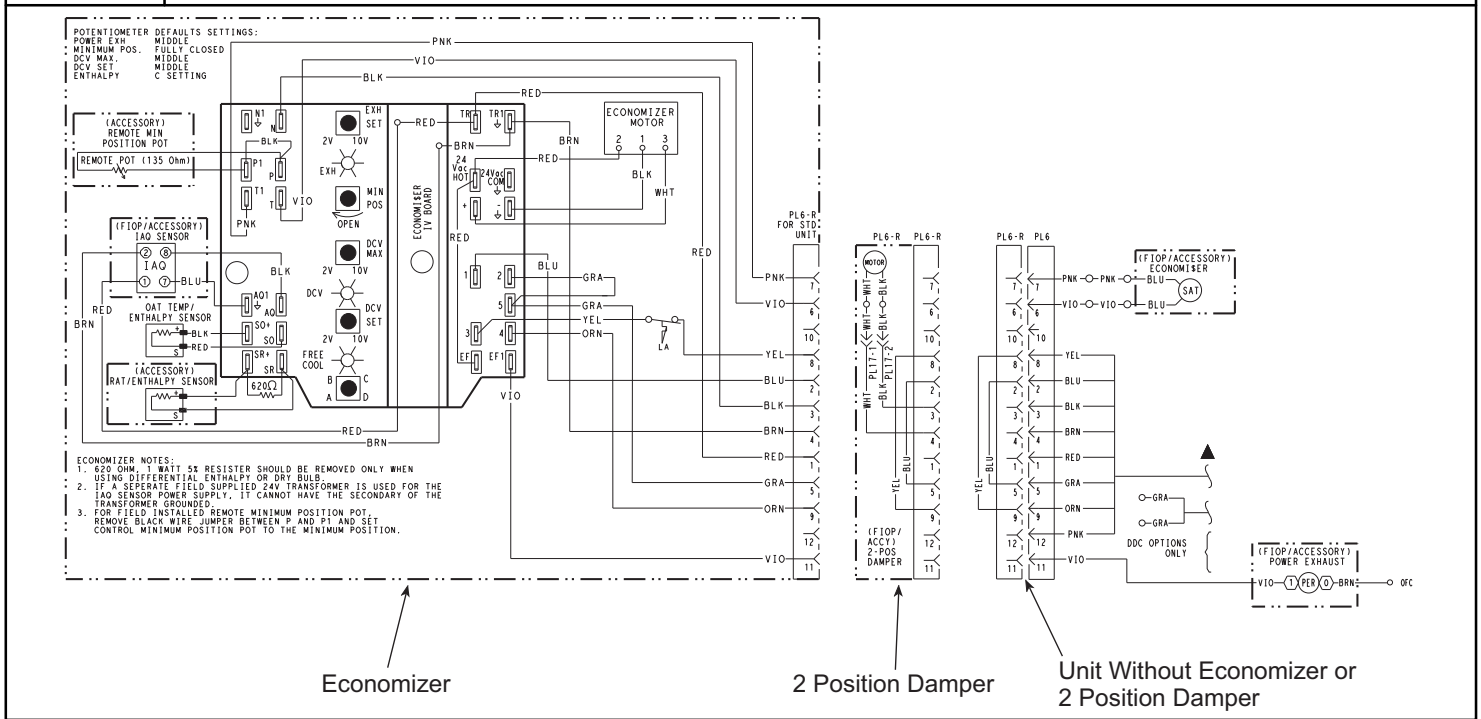

**Step 12 — Adjust Factory-Installed Options**

**Smoke Detectors —**

Smoke detector(s) will be connected at the Central Terminal Board, at terminals marked “Smoke Shutdown”. Remove jumper JMP 3 when ready to energize unit.

**Economizer IV Occupancy Switch —**

Refer to Fig. 28 for general Economizer IV wiring. External occupancy control is managed through a connection on the Central Terminal Board.

If external occupancy control is desired, connect a time clock or remotely controlled switch (closed for Occupied, open for Unoccupied sequence) at terminals marked OCCUPANCY on CTB. Remove or cut jumper JMP 2 to complete the installation.

**Step 13 — Install Accessories**

Available accessories include:

- Roof Curb
- LP conversion kit
- Manual outside air damper
- High Altitude Gas kits

Economizer IV (with control and integrated barometric relief)

Low Ambient Controls

Thermostat / Sensors

Two-Position motorized outside air damper

Power Exhaust

Differential dry-bulb sensor (Economizer IV)

Outdoor enthalpy sensor

Differential enthalpy sensor

CO<sub>2</sub> sensor

Louvered hail guard

Phase monitor control

Winter Start kit

Refer to separate installation instructions for information on installing these accessories.

**Pre-Start and Start-Up**

This completes the mechanical installation of the unit. Refer to the unit's Service and Maintenance manual for detailed Pre-Start and Start-up instructions.

# START-UP CHECKLIST

(Remove and Store in Job File)

## I. PRELIMINARY INFORMATION

MODEL NO.: \_\_\_\_\_ SERIAL NO.: \_\_\_\_\_  
 DATE: \_\_\_\_\_ TECHNICIAN: \_\_\_\_\_

## II. PRE-START-UP (insert checkmark in box as each item is completed)

- VERIFY THAT JOBSITE VOLTAGE AGREES WITH VOLTAGE LISTED ON RATING PLATE
- VERIFY THAT ALL PACKAGING MATERIALS HAVE BEEN REMOVED FROM UNIT
- REMOVE ALL SHIPPING HOLD DOWN BOLTS AND BRACKETS PER INSTALLATION INSTRUCTIONS
- VERIFY THAT CONDENSATE CONNECTION IS INSTALLED PER INSTALLATION INSTRUCTIONS
- VERIFY THAT FLUE HOOD IS INSTALLED
- CHECK REFRIGERANT PIPING FOR INDICATIONS OF LEAKS; INVESTIGATE AND REPAIR IF NECESSARY
- CHECK GAS PIPING FOR LEAKS
- CHECK ALL ELECTRICAL CONNECTIONS AND TERMINALS FOR TIGHTNESS
- CHECK THAT RETURN (INDOOR) AIR FILTERS ARE CLEAN AND IN PLACE
- VERIFY THAT UNIT INSTALLATION IS LEVEL
- CHECK FAN WHEELS AND PROPELLER FOR LOCATION IN HOUSING/ORIFICE AND SETSCREW TIGHTNESS
- CHECK TO ENSURE THAT ELECTRICAL WIRING IS NOT IN CONTACT WITH REFRIGERANT LINES OR SHARP METAL EDGES
- CHECK PULLEY ALIGNMENT AND BELT TENSION PER INSTALLATION INSTRUCTIONS

## III. START-UP (REFER TO UNIT SERVICE/MAINTENANCE MANUAL FOR START-UP INSTRUCTIONS)

### ELECTRICAL

SUPPLY VOLTAGE	L1-L2 _____	L2-L3 _____	L3-L1 _____
CIRCUIT 1 COMPRESSOR AMPS	L1 _____	L2 _____	L3 _____
CIRCUIT 2 COMPRESSOR AMPS	L1 _____	L2 _____	L3 _____
INDOOR-FAN AMPS	L1 _____	L2 _____	L3 _____
OUTDOOR-FAN AMPS	NO. 1 _____	NO. 2 _____	NO. 3 _____
	NO. 4 _____	NO. 5 _____	NO. 6 _____

### TEMPERATURES

OUTDOOR-AIR TEMPERATURE	_____ DB	_____ WB
RETURN-AIR TEMPERATURE	_____ DB	_____ WB
COOLING SUPPLY AIR	_____ DB	_____ WB
GAS HEAT SUPPLY AIR	_____ DB	_____ WB

### PRESSURES (Heating Mode)

GAS INLET PRESSURE \_\_\_\_\_ IN. WG  
 GAS MANIFOLD PRESSURE \_\_\_\_\_ IN. WG (LOW FIRE) \_\_\_\_\_ IN. WG (HI FIRE)

**PRESSURES (Cooling Mode)**

REFRIGERANT SUCTION, CIRCUIT 1	_____ PSIG	_____ F
REFRIGERANT SUCTION, CIRCUIT 2	_____ PSIG	_____ F
REFRIGERANT DISCHARGE, CIRCUIT 1	_____ PSIG	_____ F
REFRIGERANT DISCHARGE, CIRCUIT 2	_____ PSIG	_____ F

- VERIFY THAT 3-PHASE FAN MOTOR AND BLOWER ARE ROTATING IN CORRECT DIRECTION.
- VERIFY THAT 3-PHASE SCROLL COMPRESSOR IS ROTATING IN THE CORRECT DIRECTION
- VERIFY REFRIGERANT CHARGE USING CHARGING CHARTS

**GENERAL**

- SET ECONOMIZER MINIMUM VENT AND CHANGEOVER SETTINGS TO MATCH JOB REQUIREMENTS (IF EQUIPPED)