

HW

Water-to-Water Geothermal Heat Pump
Sizes 024, 036, 048, 060

Comfortmaker
Air Conditioning & Heating

Product Data



Features & Benefits

Energy Efficiency

- 3.15 COP, 16.0 - 22.1 EER (Closed Loop)
- 3.7 COP, 20.55 - 26.30 EER (Open Loop)
- Optional supplemental domestic water heating

Comfort

- Two-stage scroll compressor

Control

- Microprocessor control

Sound

- Fully insulated cabinet with fiberglass
- Compressor blanket

Reliability, Quality and Durability

- R-410A refrigerant
- Computerized run-tested

Flexibility and Installation

- Unit designed for variety of hydronic applications

Model Number Nomenclature

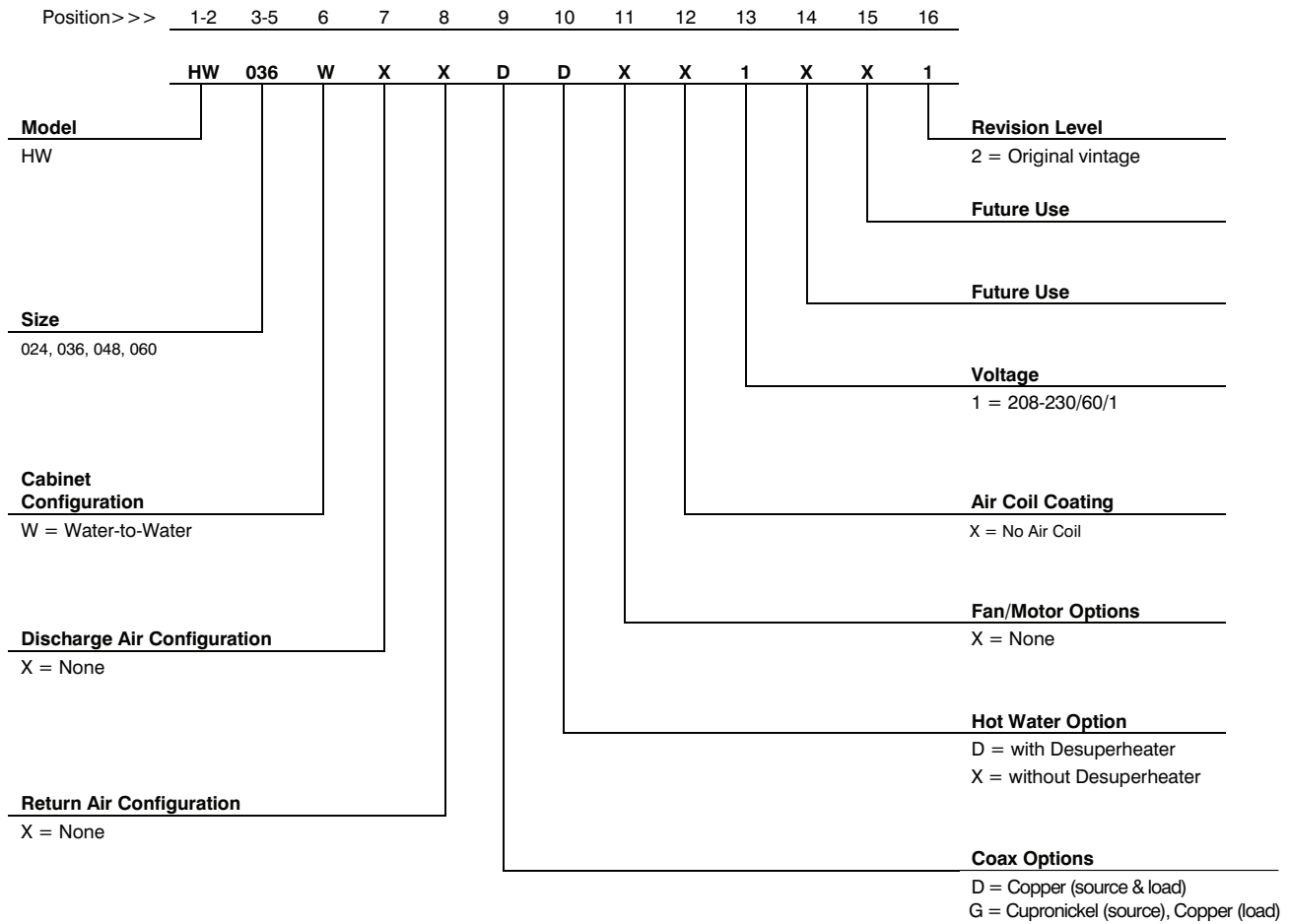

Use of the AHRI Certified TM Mark indicates a manufacturer's participation in the program. For verification of certification for individual products, go to www.ahridirectory.org.



Accessories

Factory Installed Options

- **Cupro-nickel Coil** - Recommended in conditions anticipating moderate scale formation or in brackish water (available on load and source side).
- **Domestic Hot Water Heat Recovery Package:** - Used to heat domestic hot water using the wasted heat from the hot compressed gas of the compressor.

Field Installed Accessories

- **Thermostats** - Compatible with many 2 stage heat, 2 stage cool heat pump thermostats
- **Flow Centers, hose kits, mounting pads, etc** - see Geothermal accessories catalog.

AHRI Ratings

FULL LOAD													
Model Size	GPM	Water Loop Heat Pump				Ground Water Heat Pump				Ground Loop Heat Pump			
		Cooling 86°F		Heating 68°F		Cooling 59°F		Heating 50°F		Cooling 77°F		Heating 32°F	
		Capacity Btuh	EER Btuh/W	Capacity Btuh	COP	Capacity Btuh	EER Btuh/W	Capacity Btuh	COP	Capacity Btuh	EER Btuh/W	Capacity Btuh	COP
024	8	22200	14.45	29700	4.55	25400	22.10	23800	3.70	23400	16.90	18700	3.05
036	9	32500	13.80	44100	4.60	37200	21.30	35800	3.70	34100	16.10	28300	3.05
048	12	42700	14.40	55800	4.50	48500	22.10	46200	3.60	44800	16.70	37300	3.05
060	13	52000	13.90	67500	4.40	58500	21.00	55900	3.60	54400	16.20	45400	3.05

PART LOAD													
Model Size	GPM	Water Loop Heat Pump				Ground Water Heat Pump				Ground Loop Heat Pump			
		Cooling 86°F		Heating 68°F		Cooling 59°F		Heating 50°F		Cooling 68°F		Heating 41°F	
		Capacity Btuh	EER Btuh/W	Capacity Btuh	COP	Capacity Btuh	EER Btuh/W	Capacity Btuh	COP	Capacity Btuh	EER Btuh/W	Capacity Btuh	COP
024	8	16900	15.55	22200	4.85	19400	25.50	17600	3.70	18800	22.10	15300	3.15
036	9	23700	14.60	32500	4.90	27600	25.50	25500	3.70	26400	21.30	22100	3.15
048	12	31600	15.10	40800	4.60	36600	26.30	33500	3.60	35200	22.10	29800	3.15
060	13	38500	14.50	49600	4.50	44100	25.00	41100	3.60	42300	21.00	36700	3.15

NOTE: Ratings contained in this document are subject to change at any time. Always refer to the AHRI directory (www.ahridirectory.org) for the most up-to-date ratings information.

Physical Data

Description	HW024	HW036	HW048	HW060
Compressor Type (Qty)	Scroll (1)	Scroll (1)	Scroll (1)	Scroll (1)
Refrigeration Charge (oz)	54	59	72	72
Refrigerant Metering Device	Bi-directional thermal expansion valve (TXV)			
Max Water Working Pressure (PSIG/kPa)	450/3100	450/3100	450/3100	450/3100
Load - Water Connection Size				
FPT	3/4"	3/4"	1.0"	1.0"
Coaxial Coil Volume (gal)	0.47	0.50	0.64	0.74
Source - Water Connection Size				
FPT	3/4"	3/4"	1.0"	1.0"
Coaxial Coil Volume (gal)	0.47	0.50	0.39	0.47
Cabinet				
Weight - Operating (lbs)	290	360	360	360
Weight - Shipping (lbs)	310	310	360	380

Electrical data

Model Size	Rated Voltage	Voltage Min/Max	Compressor					
			QTY	RLA	LRA	Min Circuit Amps	MOP Calculation	Max Fuse/HACR
024	208-230/60/1	197/253	1	11.7	58.3	14.6	26.2	25
036	208-230/60/1	197/253	1	15.6	83.0	19.5	35.1	35
048	208-230/60/1	197/253	1	21.2	104.0	26.4	47.6	45
060	208-230/60/1	197/253	1	26.9	139.0	33.6	60.5	60

DIMENSIONS

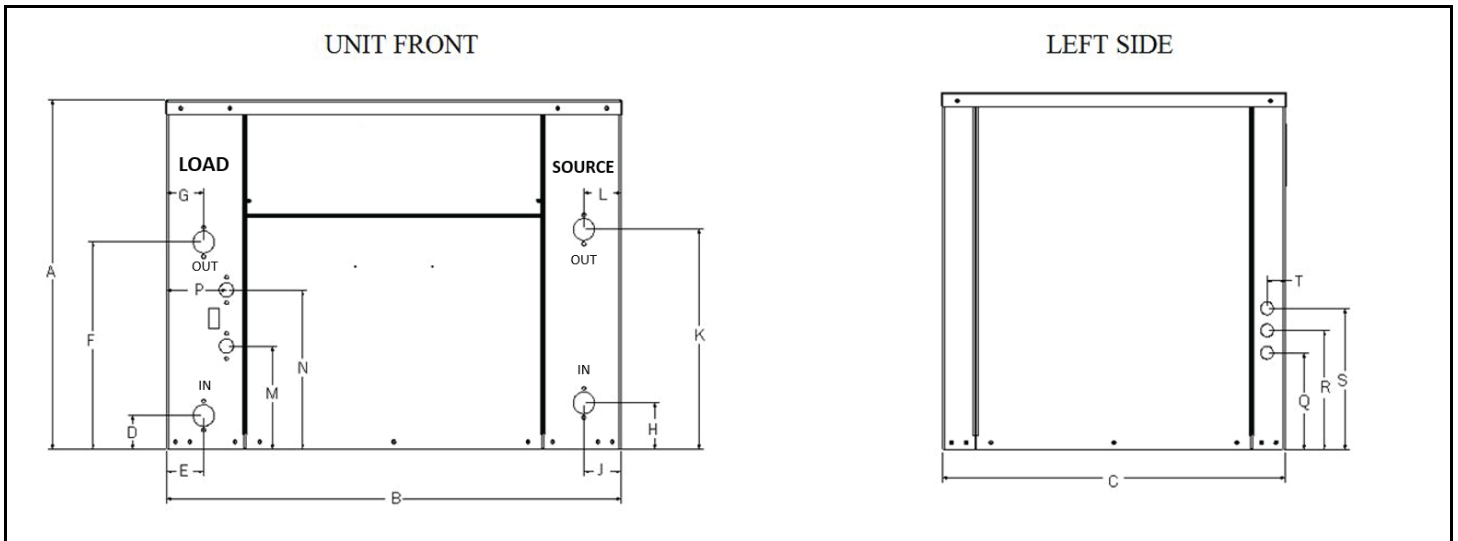

MODEL SIZE	A	B	C	D	E	F	G	H	J	K	L	M	N	P	Q	R	S	T	WATER CONN	HRP CONN
	Height	Width	Depth																	
024	24	32.5	24	2.70	2.50	13.70	2.50	3.25	1.95	14.25	1.95	7.15	11.00	4.25	6.55	8.05	9.55	1.25	3/4 FPT	1/2 FPT
036	24	32.5	24	2.30	2.55	14.30	2.65	3.80	2.67	15.80	2.67	7.24	11.12	4.31	5.80	8.05	10.3	1.25	3/4 FPT	1/2 FPT
048	24	32.5	24	2.90	2.19	16.90	2.19	3.10	2.17	17.10	2.17	7.24	11.12	4.31	5.80	8.05	10.3	1.25	1 FPT	1/2 FPT
060	24	32.5	24	2.90	2.19	16.90	2.19	3.10	2.17	17.10	2.17	7.24	11.12	4.31	5.80	8.05	10.3	1.25	1 FPT	1/2 FPT

NOTES: All dimensions within +/- 0.125"

Specifications subject to change without notice.

HW024 Heating Performance - PART LOAD cont.

SOURCE			LOAD 4 GPM						
EWT	GPM	Pressure Drop (PSI)	EWT	Heating Capacity, MBH	Power, KW	Heat Absorb, MBH	Lvg Water Temp	COP	Pressure Drop (PSI)
30	4	0.5	60						
			80	13.0	1.00	10.4	86.5	3.8	0.4
			100	12.0	1.30	8.8	106.0	2.7	0.3
			120	11.0	1.64	7.1	125.6	2.0	0.3
	6	1.0	60						
			80	13.5	1.01	10.8	86.8	3.9	0.4
			100	12.4	1.30	9.1	106.2	2.8	0.3
			120	11.3	1.65	7.4	125.7	2.0	0.3
	8	1.6	60						
			80	13.7	1.02	11.0	86.9	3.9	0.4
			100	12.6	1.31	9.3	106.3	2.8	0.3
			120	11.5	1.66	7.5	125.8	2.0	0.3
50	4	0.4	60						
			80	17.7	0.98	15.0	88.9	5.3	0.4
			100	16.5	1.28	13.1	108.3	3.8	0.3
			120	15.4	1.65	11.2	127.8	2.7	0.3
	6	0.9	60						
			80	18.4	0.99	15.7	89.2	5.5	0.4
			100	17.1	1.28	13.7	108.6	3.9	0.3
			120	15.9	1.65	11.6	128.0	2.8	0.3
	8	1.5	60						
			80	18.8	0.99	16.1	89.4	5.5	0.4
			100	17.4	1.29	14.0	108.8	4.0	0.3
			120	16.1	1.66	11.8	128.2	2.8	0.3
70	4	0.4	60	24.3	0.71	22.3	72.1	10.1	0.4
			80	22.8	0.93	20.2	91.4	7.2	0.4
			100	21.3	1.24	18.0	110.7	5.0	0.3
			120						
	6	0.8	60	25.5	0.70	23.5	72.7	10.6	0.4
			80	23.8	0.93	21.2	91.9	7.5	0.4
			100						
			120						
	8	1.4	60	26.2	0.70	24.2	73.1	10.9	0.4
			80	24.3	0.93	21.7	92.2	7.6	0.4
			100						
			120						
90	4	0.4	60						
			80						
			100						
			120						
	6	0.8	60						
			80						
			100						
			120						
	8	1.3	60						
			80						
			100						
			120						

Notes::

- 1 Antifreeze required on Load side for this operation
- 2 Interpolation is permissible. Not extrapolation
- 3 XXXXXXXXXX = Operation not recommended

HW024 Heating Performance - PART LOAD cont.

SOURCE			LOAD 6 GPM												
EWT	GPM	Pressure Drop (PSI)	EWT	Heating Capacity, MBH	Power, KW	Heat Absorb, MBH	Lvg Water Temp	COP	Pressure Drop (PSI)						
30	4	0.5	60												
			80												
			100												
			120	13.1	0.98	10.5	84.4	3.9	0.8						
	6	1.0	60	13.6	0.99	11.0	84.5	4.0	0.8						
			80	13.9	1.00	11.2	84.6	4.1	0.8						
			100	12.1	1.28	8.9	104.1	2.8	0.7						
			120	12.5	1.28	9.3	104.2	2.9	0.7						
	8	1.6	60	12.7	1.29	9.4	104.3	2.9	0.7						
			80	11.1	1.62	7.2	123.7	2.0	0.7						
			100	11.4	1.63	7.5	123.8	2.1	0.7						
			120	11.6	1.64	7.6	123.9	2.1	0.7						
50	4	0.4	60												
			80												
			100												
			120	17.8	0.95	15.3	86.0	5.5	0.8						
	6	0.9	60	18.6	0.95	16.0	86.2	5.7	0.8						
			80	19.0	0.96	16.4	86.4	5.8	0.8						
			100	16.6	1.25	13.4	105.6	3.9	0.7						
			120	17.2	1.25	13.9	105.8	4.0	0.7						
	8	1.5	60	17.6	1.26	14.2	105.9	4.1	0.7						
			80	15.5	1.62	11.4	125.2	2.8	0.7						
			100	16.0	1.62	11.8	125.4	2.9	0.7						
			120	16.3	1.62	12.1	125.5	2.9	0.7						
70	4	0.4	60	24.6	0.67	22.7	68.2	10.7	0.8						
			80	25.9	0.67	24.0	68.6	11.4	0.8						
			100	26.6	0.67	24.7	68.9	11.7	0.8						
			120	23.1	0.89	20.6	87.7	7.6	0.8						
	6	0.8	60	24.1	0.88	21.7	88.1	8.0	0.8						
			80												
			100							21.5	1.19	18.3	107.2	5.3	0.7
			120												
	8	1.4	60												
			80												
			100												
			120												
90	4	0.4	60												
			80												
			100												
			120												
	6	0.8	60												
			80												
			100												
			120												
	8	1.3	60												
			80												
			100												
			120												

Notes::

- 1 Antifreeze required on Load side for this operation
- 2 Interpolation is permissible. Not extrapolation
- 3 XXXXXXXXXX = Operation not recommended

HW024 Heating Performance - PART LOAD cont.

SOURCE			LOAD 8 GPM												
EWT	GPM	Pressure Drop (PSI)	EWT	Heating Capacity, MBH	Power, KW	Heat Absorb, MBH	Lvg Water Temp	COP	Pressure Drop (PSI)						
30	4	0.5	60												
			80												
			100												
			120	13.2	0.98	10.6	83.3	4.0	1.3						
	6	1.0	60	13.7	0.98	11.1	83.4	4.1	1.3						
			80	13.9	0.99	11.3	83.5	4.1	1.3						
			100	12.1	1.27	9.0	103.1	2.8	1.3						
			120	12.5	1.28	9.3	103.2	2.9	1.3						
	8	1.6	60	12.8	1.28	9.5	103.2	2.9	1.3						
			80	11.2	1.62	7.3	122.8	2.0	1.2						
			100	11.5	1.62	7.5	122.9	2.1	1.2						
			120	11.6	1.63	7.7	122.9	2.1	1.2						
50	4	0.4	60												
			80												
			100												
			120	18.0	0.94	15.4	84.5	5.6	1.3						
	6	0.9	60	18.7	0.94	16.1	84.7	5.8	1.3						
			80	19.1	0.95	16.5	84.8	5.9	1.3						
			100	16.7	1.24	13.5	104.2	4.0	1.3						
			120	17.3	1.24	14.1	104.4	4.1	1.3						
	8	1.5	60	17.7	1.24	14.4	104.5	4.2	1.3						
			80	15.6	1.60	11.5	123.9	2.9	1.2						
			100	16.1	1.60	11.9	124.1	2.9	1.2						
			120	16.4	1.61	12.2	124.1	3.0	1.2						
70	4	0.4	60												
			80												
			100												
			120	23.3	0.88	20.8	85.8	7.8	1.3						
	6	0.8	60	24.3	0.87	21.9	86.1	8.2	1.3						
			80												
			100							21.7	1.17	18.5	105.5	5.4	1.3
			120							22.5	1.17	19.4	105.7	5.7	1.3
	8	1.4	60	23.0	1.17	19.8	105.8	5.8	1.3						
			80	20.2	1.56	16.1	125.1	3.8	1.2						
			100												
			120												
90	4	0.4	60												
			80												
			100												
			120												
	6	0.8	60												
			80												
			100												
			120												
	8	1.3	60												
			80												
			100												
			120												

Notes::

- 1 Antifreeze required on Load side for this operation
- 2 Interpolation is permissible. Not extrapolation
- 3 XXXXXXXXXX = Operation not recommended

HW024 Heating Performance - FULL LOAD

SOURCE			LOAD 4 GPM						
EWT	GPM	Pressure Drop (PSI)	EWT	Heating Capacity, MBH	Power, KW	Heat Absorb, MBH	Lvg Water Temp	COP	Pressure Drop (PSI)
30	4	0.5	60						
			80	18.0	1.32	14.3	89.0	4.0	0.4
			100	17.1	1.66	12.6	108.6	3.0	0.3
			120	16.3	2.12	10.8	128.3	2.3	0.3
	6	1.0	60						
			80	18.8	1.34	15.0	89.4	4.1	0.4
			100	17.7	1.67	13.2	108.9	3.1	0.3
			120	16.9	2.13	11.2	128.5	2.3	0.3
	8	1.6	60						
			80	19.2	1.35	15.4	89.7	4.2	0.4
			100	18.1	1.69	13.5	109.1	3.1	0.3
			120	17.1	2.15	11.4	128.7	2.3	0.3
50	4	0.4	60	24.0	1.12	20.7	72.0	6.3	0.4
			80	23.3	1.39	19.3	91.7	4.9	0.4
			100	22.2	1.73	17.4	111.2	3.8	0.3
			120	21.3	2.20	15.3	130.8	2.8	0.3
	6	0.9	60	25.7	1.14	22.4	72.9	6.6	0.4
			80	24.5	1.41	20.4	92.3	5.1	0.4
			100	23.2	1.75	18.3	111.7	3.9	0.3
			120	22.1	2.22	16.0	131.2	2.9	0.3
	8	1.5	60	26.6	1.16	23.2	73.3	6.7	0.4
			80	25.2	1.43	21.1	92.6	5.2	0.4
			100	23.7	1.77	18.8	112.0	3.9	0.3
			120	22.5	2.23	16.4	131.4	3.0	0.3
70	4	0.4	60	29.9	1.18	26.4	75.0	7.4	0.4
			80	29.6	1.47	25.4	94.9	5.9	0.4
			100	28.3	1.81	23.2	114.3	4.6	0.3
			120	27.0	2.28	20.6	133.7	3.5	0.3
	6	0.8	60	32.8	1.22	29.2	76.4	7.9	0.4
			80	31.3	1.49	27.0	95.7	6.2	0.4
			100	29.6	1.83	24.4	114.9	4.7	0.3
			120						
	8	1.4	60	34.1	1.24	30.4	77.0	8.1	0.4
			80	32.2	1.51	27.9	96.2	6.3	0.4
			100						
			120						
90	4	0.4	60						
			80						
			100						
			120						
	6	0.8	60						
			80						
			100						
			120						
	8	1.3	60						
			80						
			100						
			120						

Notes::

- 1 Antifreeze required on Load side for this operation
- 2 Interpolation is permissible. Not extrapolation
- 3 XXXXXXXXXX = Operation not recommended

HW024 Heating Performance - FULL LOAD cont.

SOURCE			LOAD 6 GPM						
EWT	GPM	Pressure Drop (PSI)	EWT	Heating Capacity, MBH	Power, KW	Heat Absorb, MBH	Lvg Water Temp	COP	Pressure Drop (PSI)
30	4	0.5	60						
			80	18.1	1.29	14.5	86.1	4.1	0.8
			100	17.2	1.62	12.8	105.8	3.1	0.7
			120	16.4	2.08	10.9	125.5	2.3	0.7
	6	1.0	60						
			80	18.9	1.30	15.3	86.3	4.3	0.8
			100	17.8	1.63	13.4	106.0	3.2	0.7
			120	16.9	2.09	11.4	125.7	2.4	0.7
	8	1.6	60						
			80	19.4	1.32	15.7	86.5	4.3	0.8
			100	18.2	1.64	13.7	106.1	3.2	0.7
			120	17.2	2.10	11.6	125.8	2.4	0.7
50	4	0.4	60						
			80	23.4	1.35	19.6	87.8	5.1	0.8
			100	22.4	1.68	17.7	107.5	3.9	0.7
			120	21.4	2.14	15.5	127.2	2.9	0.7
	6	0.9	60						
			80	24.7	1.36	20.8	88.3	5.3	0.8
			100	23.4	1.69	18.7	107.9	4.1	0.7
			120	22.2	2.15	16.3	127.5	3.0	0.7
	8	1.5	60						
			80	25.5	1.38	21.5	88.5	5.4	0.8
			100	24.0	1.71	19.2	108.1	4.1	0.7
			120	22.7	2.16	16.7	127.7	3.1	0.7
70	4	0.4	60	30.4	1.12	27.1	70.1	7.9	0.8
			80	29.9	1.41	25.8	90.0	6.2	0.8
			100	28.5	1.74	23.6	109.6	4.8	0.7
			120	27.2	2.20	21.0	129.2	3.6	0.7
	6	0.8	60	33.8	1.16	30.4	71.3	8.6	0.8
			80	31.8	1.43	27.6	90.6	6.5	0.8
			100	30.0	1.75	25.0	110.1	5.0	0.7
			120						
	8	1.4	60	34.5	1.17	31.0	71.5	8.7	0.8
			80	32.7	1.44	28.5	91.0	6.7	0.8
			100	30.8	1.77	25.7	110.4	5.1	0.7
			120						
90	4	0.4	60						
			80						
			100						
			120						
	6	0.8	60						
			80						
			100						
			120						
	8	1.3	60						
			80						
			100						
			120						

Notes::

- 1 Antifreeze required on Load side for this operation
- 2 Interpolation is permissible. Not extrapolation
- 3 XXXXXXXXXX = Operation not recommended

HW024 Heating Performance - FULL LOAD cont.

SOURCE			LOAD 8 GPM						
EWT	GPM	Pressure Drop (PSI)	EWT	Heating Capacity, MBH	Power, KW	Heat Absorb, MBH	Lvg Water Temp	COP	Pressure Drop (PSI)
30	4	0.5	60						
			80	18.2	1.28	14.6	84.6	4.2	1.3
			100	17.2	1.61	12.9	104.3	3.2	1.3
			120	16.5	2.06	11.0	124.2	2.3	1.2
	6	1.0	60						
			80	19.1	1.29	15.4	84.8	4.3	1.3
			100	17.9	1.62	13.5	104.5	3.3	1.3
			120	17.0	2.07	11.5	124.3	2.4	1.2
	8	1.6	60						
			80	19.5	1.31	15.8	84.9	4.4	1.3
			100	18.3	1.63	13.8	104.6	3.3	1.3
			120	17.3	2.08	11.7	124.4	2.4	1.2
50	4	0.4	60						
			80	23.6	1.33	19.8	85.9	5.2	1.3
			100	22.5	1.66	17.8	105.7	4.0	1.3
			120	21.5	2.11	15.7	125.4	3.0	1.2
	6	0.9	60						
			80	24.9	1.34	21.0	86.2	5.4	1.3
			100	23.5	1.67	18.8	105.9	4.1	1.3
			120	22.3	2.12	16.4	125.6	3.1	1.2
	8	1.5	60						
			80	25.6	1.36	21.7	86.4	5.5	1.3
			100	24.1	1.68	19.4	106.1	4.2	1.3
			120	22.8	2.14	16.9	125.8	3.1	1.2
70	4	0.4	60						
			80	30.1	1.38	26.1	87.5	6.4	1.3
			100	28.7	1.71	23.8	107.2	4.9	1.3
			120	27.3	2.15	21.3	126.9	3.7	1.2
	6	0.8	60						
			80	32.0	1.40	27.9	88.0	6.7	1.3
			100	30.2	1.72	25.3	107.6	5.1	1.3
			120						
	8	1.4	60	34.7	1.14	31.3	68.7	8.9	1.4
			80	33.0	1.41	28.9	88.3	6.9	1.3
			100	31.0	1.74	26.1	107.8	5.2	1.3
			120						
90	4	0.4	60						
			80						
			100						
			120						
	6	0.8	60						
			80						
			100						
			120						
	8	1.3	60						
			80						
			100						
			120						

Notes::

- 1 Antifreeze required on Load side for this operation
- 2 Interpolation is permissible. Not extrapolation
- 3 XXXXXXXXXX = Operation not recommended

HW024 Cooling Performance - PART LOAD

SOURCE			LOAD 4 GPM						
EWT	GPM	Pressure Drop (PSI)	EWT	Cooling Capacity, MBH	Power, KW	Loop Rej/Add, MBH	Lvg Water Temp	EER	Pressure Drop (PSI)
50	4	0.4	50						
			60						
			70						
			80						
			90						
	6	0.9	50						
			60						
			70						
			80						
			90						
	8	1.4	50						
			60						
70									
80									
90									
70	4	0.4	50	14.1	0.80	16.3	43.0	17.6	0.4
			60	18.8	0.78	20.9	50.7	23.9	0.4
			70	21.7	0.77	23.8	59.2	28.4	0.4
			80						
			90						
	6	0.8	50	16.2	0.77	18.4	41.9	21.0	0.4
			60	19.0	0.75	21.1	50.5	25.2	0.4
			70	22.0	0.73	24.0	59.0	30.1	0.4
			80						
			90						
	8	1.3	50	16.4	0.77	18.5	41.9	21.4	0.4
			60	19.0	0.75	21.2	50.5	25.5	0.4
70			22.1	0.72	24.2	58.9	30.8	0.4	
80									
90									
90	4	0.4	50	14.5	1.09	17.4	42.8	13.4	0.4
			60	17.1	1.08	20.0	51.5	15.9	0.4
			70	19.8	1.06	22.7	60.1	18.7	0.4
			80						
			90						
	6	0.8	50	14.8	1.06	17.6	42.7	14.0	0.4
			60	17.3	1.04	20.2	51.4	16.7	0.4
			70	20.2	1.01	23.0	59.9	20.0	0.4
			80						
			90						
	8	1.3	50	14.9	1.05	17.7	42.6	14.2	0.4
			60	17.5	1.02	20.3	51.3	17.1	0.4
70			20.4	1.00	23.1	59.8	20.5	0.4	
80									
90									
110	4	0.3	50	12.7	1.40	16.4	43.7	9.1	0.4
			60	15.1	1.40	18.8	52.5	10.8	0.4
			70						
			80						
			90						
	6	0.7	50	12.9	1.37	16.5	43.6	9.4	0.4
			60	15.4	1.36	19.0	52.3	11.4	0.4
			70						
			80						
			90						
	8	1.2	50	13.0	1.36	16.6	43.5	9.6	0.4
			60	15.5	1.34	19.1	52.3	11.6	0.4
70			18.2	1.32	21.7	60.9	13.8	0.4	
80									
90									

- Notes::
- 1 Antifreeze required on Load side for this operation
 - 2 Interpolation is permissible. Not extrapolation
 - 3 XXXXXXXXXX = Operation not recommended

HW024 Cooling Performance - PART LOAD cont.

SOURCE			LOAD 6 GPM						
EWT	GPM	Pressure Drop (PSI)	EWT	Cooling Capacity, MBH	Power, KW	Loop Rej/Add, MBH	Lvg Water Temp	EER	Pressure Drop (PSI)
50	4	0.4	50						
			60						
			70						
			80						
			90						
	6	0.9	50						
			60						
			70						
			80						
			90						
	8	1.4	50						
			60						
			70						
			80						
			90						
70	4	0.4	50	16.8	0.80	19.0	44.4	20.9	0.9
			60	19.5	0.79	21.7	53.5	24.9	0.9
			70	22.7	0.76	24.8	62.4	29.8	0.8
			80						
			90						
	6	0.8	50	16.8	0.77	19.0	44.4	21.7	0.9
			60	20.1	0.75	22.2	53.3	26.8	0.9
			70	23.1	0.72	25.2	62.3	31.9	0.8
			80						
			90						
	8	1.3	50	17.1	0.77	19.3	44.3	22.4	0.9
			60	19.6	0.75	21.7	53.5	26.3	0.9
			70	23.5	0.71	25.5	62.2	33.0	0.8
			80						
			90						
90	4	0.4	50	15.3	1.09	18.2	44.9	14.0	0.9
			60	18.0	1.08	20.9	54.0	16.8	0.9
			70						
			80						
			90						
	6	0.8	50	15.6	1.06	18.4	44.8	14.8	0.9
			60	18.4	1.03	21.2	53.9	17.8	0.9
			70						
			80						
			90						
	8	1.3	50	15.7	1.04	18.5	44.8	15.0	0.9
			60	18.5	1.02	21.3	53.8	18.2	0.9
			70						
			80						
			90						
110	4	0.3	50	13.3	1.41	16.9	45.6	9.4	0.9
			60	15.8	1.40	19.5	54.7	11.3	0.9
			70						
			80						
			90						
	6	0.7	50	13.5	1.37	17.1	45.5	9.9	0.9
			60	16.1	1.36	19.7	54.6	11.9	0.9
			70						
			80						
			90						
	8	1.2	50	13.6	1.36	17.2	45.5	10.0	0.9
			60	16.3	1.34	19.9	54.6	12.1	0.9
			70						
			80						
			90						

Notes::

- 1 Antifreeze required on Load side for this operation
- 2 Interpolation is permissible. Not extrapolation
- 3 XXXXXXXXXX = Operation not recommended

HW024 Cooling Performance - PART LOAD cont.

SOURCE			LOAD 8 GPM						
EWT	GPM	Pressure Drop (PSI)	EWT	Cooling Capacity, MBH	Power, KW	Loop Rej/Add, MBH	Lvg Water Temp	EER	Pressure Drop (PSI)
50	4	0.4	50						
			60						
			70						
			80						
	6	0.9	50						
			60						
			70						
			80						
	8	1.4	50						
			60						
			70						
			80						
70	4	0.4	50	17.2	0.81	19.5	45.7	21.4	1.5
			60	20.2	0.79	22.4	55.0	25.5	1.4
			70	23.3	0.77	25.4	64.2	30.4	1.4
			80						
	6	0.8	50	17.5	0.78	19.7	45.6	22.5	1.5
			60	20.6	0.76	22.7	54.9	27.3	1.4
			70						
			80						
	8	1.3	50	17.7	0.77	19.9	45.6	23.0	1.5
			60	20.7	0.75	22.8	54.8	27.8	1.4
			70						
			80						
90	4	0.4	50	15.7	1.10	18.6	46.1	14.3	1.5
			60	18.5	1.08	21.4	55.4	17.1	1.4
			70						
			80						
	6	0.8	50	16.0	1.06	18.8	46.0	15.0	1.5
			60	18.9	1.04	21.7	55.3	18.2	1.4
			70						
			80						
	8	1.3	50	16.1	1.05	19.0	46.0	15.4	1.5
			60	19.1	1.02	21.9	55.2	18.7	1.4
			70						
			80						
110	4	0.3	50	13.6	1.42	17.3	46.6	9.6	1.5
			60	16.2	1.41	19.9	56.0	11.5	1.4
			70						
			80						
	6	0.7	50	13.8	1.38	17.4	46.6	10.0	1.5
			60	16.5	1.36	20.1	55.9	12.1	1.4
			70						
			80						
	8	1.2	50	13.9	1.37	17.5	46.5	10.2	1.5
			60	16.7	1.35	20.3	55.8	12.4	1.4
			70						
			80						

- Notes::
- 1 Antifreeze required on Load side for this operation
 - 2 Interpolation is permissible. Not extrapolation
 - 3 [Redacted] = Operation not recommended

HW024 Cooling Performance - FULL LOAD

SOURCE			LOAD							
EWT	GPM	Pressure Drop (PSI)	4 GPM							
			EWT	Cooling Capacity, MBH	Power, KW	Loop Rej/Add, MBH	Lvg Water Temp	EER	Pressure Drop (PSI)	
50	4	0.4	50							
			60							
			70							
			80							
			90	36.6	1.09	39.9	71.6	33.7	0.4	
	6	0.9	50							
			60							
			70							
			80							
			90							
			90							
	8	1.4	50							
60										
70										
80										
90										
90										
70	4	0.4	50	20.5	1.19	23.9	39.8	17.2	0.4	
			60	23.9	1.23	27.4	48.1	19.4	0.4	
			70	26.6	1.26	30.3	56.7	21.2	0.4	
			80	30.6	1.30	34.4	64.7	23.7	0.4	
			90							
	6	0.8	50	20.5	1.15	23.9	39.8	17.9	0.4	
			60	24.3	1.18	27.8	47.9	20.7	0.4	
			70	27.3	1.20	30.9	56.4	22.8	0.4	
			80	31.0	1.23	34.6	64.5	25.3	0.4	
			90							
	8	1.3	50	20.7	1.13	24.0	39.7	18.3	0.4	
			60	24.0	1.15	27.4	48.0	20.8	0.4	
			70	27.5	1.18	31.0	56.3	23.4	0.4	
			80	29.4	1.19	32.9	65.3	24.8	0.4	
			90							
90	4	0.4	50	18.5	1.49	22.7	40.8	12.4	0.4	
			60	21.5	1.53	25.9	49.3	14.1	0.4	
			70	24.9	1.57	29.4	57.5	15.9	0.4	
			80							
			90							
	6	0.8	50	18.5	1.44	22.6	40.8	12.8	0.4	
			60	20.8	1.47	25.0	49.6	14.2	0.4	
			70	25.5	1.50	29.9	57.3	17.0	0.4	
			80							
			90							
	8	1.3	50	19.2	1.43	23.2	40.5	13.4	0.4	
			60	21.7	1.45	25.8	49.2	15.0	0.4	
			70	25.1	1.47	29.3	57.5	17.1	0.4	
			80	28.6	1.49	33.0	65.7	19.2	0.4	
			90							
110	4	0.3	50	16.5	1.88	21.7	41.8	8.8	0.4	
			60	19.6	1.92	25.0	50.2	10.2	0.4	
			70	22.6	1.96	28.1	58.7	11.6	0.4	
			80							
			90							
	6	0.7	50	15.5	1.81	20.5	42.3	8.6	0.4	
			60	20.0	1.85	25.2	50.0	10.8	0.4	
			70	22.9	1.88	28.2	58.5	12.2	0.4	
			80							
			90							
	8	1.2	50	17.1	1.80	22.1	41.5	9.5	0.4	
			60	20.0	1.82	25.1	50.0	11.0	0.4	
			70	23.2	1.84	28.4	58.4	12.6	0.4	
			80							
			90							

Notes::

- 1 Antifreeze required on Load side for this operation
- 2 Interpolation is permissible. Not extrapolation
- 3 XXXXXXXXXX = Operation not recommended

HW024 Cooling Performance - FULL LOAD cont.

SOURCE			LOAD 6 GPM						
EWT	GPM	Pressure Drop (PSI)	EWT	Cooling Capacity, MBH	Power, KW	Loop Rej/Add, MBH	Lvg Water Temp	EER	Pressure Drop (PSI)
50	4	0.4	50						
			60						
			70						
			80	35.5	1.08	38.8	68.2	32.9	0.8
			90	39.2	1.11	42.5	76.9	35.2	0.8
	6	0.9	50						
			60						
			70						
			80						
			90						
	8	1.4	50						
			60						
70									
80									
90									
70	4	0.4	50	21.3	1.21	24.8	42.9	17.7	0.9
			60	25.4	1.25	29.1	51.6	20.3	0.9
			70	28.4	1.28	32.1	60.5	22.2	0.8
			80						
			90						
	6	0.8	50	22.1	1.16	25.5	42.7	19.0	0.9
			60	25.3	1.19	28.8	51.6	21.3	0.9
			70	29.5	1.22	33.1	60.2	24.1	0.8
			80						
			90						
	8	1.3	50	22.5	1.15	25.9	42.5	19.6	0.9
			60	26.3	1.17	29.8	51.3	22.4	0.9
70			29.4	1.19	32.9	60.2	24.6	0.8	
80									
90									
90	4	0.4	50	18.6	1.50	22.9	43.8	12.4	0.9
			60	22.7	1.55	27.1	52.4	14.7	0.9
			70	26.2	1.59	30.8	61.3	16.5	0.8
			80						
			90						
	6	0.8	50	19.9	1.46	24.1	43.4	13.6	0.9
			60	23.4	1.49	27.7	52.2	15.7	0.9
			70	27.0	1.52	31.4	61.0	17.8	0.8
			80						
			90						
	8	1.3	50	20.0	1.44	24.2	43.4	13.9	0.9
			60	23.4	1.47	27.6	52.2	16.0	0.9
70			27.2	1.49	31.6	60.9	18.3	0.8	
80									
90									
110	4	0.3	50	17.5	1.90	22.8	44.2	9.2	0.9
			60	20.5	1.93	25.9	53.2	10.6	0.9
			70	23.7	1.97	29.3	62.1	12.0	0.8
			80						
			90						
	6	0.7	50	17.8	1.84	22.9	44.1	9.7	0.9
			60	20.9	1.86	26.1	53.1	11.2	0.9
			70	24.2	1.89	29.6	61.9	12.8	0.8
			80						
			90						
	8	1.2	50	17.9	1.81	23.0	44.1	9.9	0.9
			60	20.9	1.83	26.0	53.1	11.4	0.9
70			24.6	1.86	29.8	61.8	13.2	0.8	
80									
90									

Notes::

- 1 Antifreeze required on Load side for this operation
- 2 Interpolation is permissible. Not extrapolation
- 3 XXXXXXXXXX = Operation not recommended

HW024 Cooling Performance - FULL LOAD cont.

SOURCE			LOAD 8 GPM						
EWT	GPM	Pressure Drop (PSI)	EWT	Cooling Capacity, MBH	Power, KW	Loop Rej/Add, MBH	Lvg Water Temp	EER	Pressure Drop (PSI)
50	4	0.4	50						
			60						
			70						
			80	37.1	1.10	40.5	70.7	33.6	1.3
			90	40.7	1.13	44.1	79.8	36.0	1.3
	6	0.9	50						
			60						
			70						
			80						
			90						
			90						
	8	1.4	50						
60									
70									
80									
90									
90									
70	4	0.4	50	21.9	1.22	25.5	44.6	17.9	1.5
			60	25.9	1.26	29.6	53.5	20.5	1.4
			70	29.7	1.30	33.5	62.6	22.8	1.4
			80						
			90						
	6	0.8	50	21.9	1.17	25.4	44.5	18.7	1.5
			60	26.6	1.21	30.2	53.4	22.0	1.4
			70	30.0	1.23	33.7	62.5	24.3	1.4
			80						
			90						
			90						
	8	1.3	50	23.2	1.16	26.7	44.2	20.0	1.5
60			27.1	1.19	30.6	53.3	22.8	1.4	
70			29.3	1.20	32.9	62.7	24.4	1.4	
80									
90									
90									
90	4	0.4	50	20.1	1.53	24.5	45.0	13.2	1.5
			60	23.5	1.57	28.0	54.1	15.0	1.4
			70	27.0	1.61	31.6	63.2	16.8	1.4
			80						
			90						
	6	0.8	50	20.7	1.48	24.9	44.8	14.0	1.5
			60	24.0	1.51	28.3	54.0	15.9	1.4
			70	27.7	1.54	32.2	63.1	18.1	1.4
			80						
			90						
			90						
	8	1.3	50	20.6	1.46	24.7	44.9	14.1	1.5
60			24.2	1.48	28.5	54.0	16.3	1.4	
70			27.6	1.50	32.0	63.1	18.4	1.4	
80									
90									
90									
110	4	0.3	50	18.0	1.91	23.4	45.5	9.4	1.5
			60	21.1	1.95	26.6	54.7	10.8	1.4
			70						
			80						
			90						
	6	0.7	50	18.4	1.85	23.5	45.4	9.9	1.5
			60	21.6	1.88	26.9	54.6	11.5	1.4
			70						
			80						
			90						
			90						
	8	1.2	50	18.5	1.83	23.7	45.4	10.2	1.5
60			21.8	1.85	27.0	54.6	11.8	1.4	
70									
80									
90									
90									

- Notes::
- 1 Antifreeze required on Load side for this operation
 - 2 Interpolation is permissible. Not extrapolation
 - 3 [Redacted] = Operation not recommended

HW036 Heating Performance - PART LOAD

SOURCE			LOAD							
EWT	GPM	Pressure Drop (PSI)	4.5 GPM							
			EWT	Heating Capacity, MBH	Power, KW	Heat Absorb, MBH	Lvg Water Temp	COP	Pressure Drop (PSI)	
30	4.5	0.6	60							
			80	18.4	1.48	14.3	88.2	3.6	0.5	
			100	17.6	1.95	12.3	107.9	2.6	0.4	
			120	16.9	2.55	10.2	127.6	2.0	0.4	
	6.75	1.2	60							
			80	19.2	1.49	15.0	88.6	3.8	0.5	
			100	18.3	1.95	13.0	108.2	2.7	0.4	
			120	17.5	2.55	10.7	127.9	2.0	0.4	
	9	1.9	60							
			80	19.7	1.50	15.5	88.8	3.9	0.5	
			100	18.7	1.97	13.3	108.4	2.8	0.4	
			120	17.7	2.56	10.9	128.0	2.0	0.4	
50	4.5	0.5	60	28.9	1.31	25.0	72.9	6.5	0.5	
			80	27.5	1.69	22.6	92.3	4.8	0.5	
			100	26.2	2.19	19.9	111.7	3.5	0.4	
			120	25.8	2.83	17.8	131.6	2.7	0.4	
	6.75	1.1	60	31.0	1.32	27.1	73.8	6.9	0.5	
			80	29.7	1.70	24.7	93.3	5.1	0.5	
			100	28.0	2.20	21.6	112.5	3.7	0.4	
			120	27.1	2.84	18.9	132.2	2.8	0.4	
	9	1.8	60	32.4	1.34	28.3	74.4	7.1	0.5	
			80	30.6	1.71	25.6	93.7	5.2	0.5	
			100	28.7	2.22	22.3	112.9	3.8	0.4	
			120	27.7	2.85	19.6	132.5	2.9	0.4	
70	4.5	0.5	60	34.3	1.11	30.9	75.2	9.1	0.5	
			80	33.0	1.43	28.8	94.7	6.8	0.5	
			100	31.6	1.88	26.3	114.2	4.9	0.4	
			120	30.0	2.42	23.1	133.5	3.6	0.4	
	6.75	1.0	60	37.4	1.11	34.0	76.6	9.9	0.5	
			80	35.0	1.44	30.8	95.6	7.1	0.5	
			100	33.0	1.89	27.6	114.8	5.1	0.4	
			120	31.4	2.42	24.5	134.1	3.8	0.4	
	9	1.7	60	38.3	1.12	35.0	77.0	10.0	0.5	
			80	36.2	1.45	31.9	96.2	7.3	0.5	
			100	34.0	1.90	28.6	115.3	5.3	0.4	
			120							
90	4.5	0.5	60							
			80							
			100							
			120							
	6.75	1.0	60							
			80							
			100							
			120							
	9	1.6	60							
			80							
			100							
			120							

Notes::

- 1 Antifreeze required on Load side for this operation
- 2 Interpolation is permissible. Not extrapolation
- 3 [Redacted] = Operation not recommended

HW036 Heating Performance - PART LOAD cont.

SOURCE			LOAD 6.75 GPM								
EWT	GPM	Pressure Drop (PSI)	EWT	Pressure Drop (PSI)	Heating Capacity, MBH	Power, KW	Heat Absorb, MBH	Lvg Water Temp	COP	Pressure Drop (PSI)	
30	4.5	0.6	60								
			80	0.5	18.3	1.45	14.2	85.4	3.7	1.0	
			100	0.4	17.6	1.92	12.4	105.3	2.7	0.9	
			120	0.4	17.0	2.52	10.3	125.1	2.0	0.9	
	6.75	1.2	60								
			80	0.5	19.3	1.45	15.2	85.7	3.9	1.0	
			100	0.4	18.4	1.92	13.1	105.5	2.8	0.9	
			120	0.4	17.5	2.52	10.8	125.3	2.0	0.9	
	9	1.9	60								
			80	0.5	19.9	1.46	15.7	85.9	4.0	1.0	
			100	0.4	18.8	1.93	13.5	105.6	2.9	0.9	
			120	0.4	17.8	2.53	11.1	125.3	2.1	0.9	
50	4.5	0.5	60	0.5	29.5	1.25	25.7	68.7	6.9	1.0	
			80	0.5	28.3	1.61	23.5	88.4	5.1	1.0	
			100	0.4	26.8	2.11	20.7	108.0	3.7	0.9	
			120	0.4	25.9	2.75	18.0	127.8	2.8	0.9	
	6.75	1.1	60	0.5	31.2	1.26	27.4	69.2	7.3	1.0	
			80	0.5	30.1	1.62	25.3	89.0	5.5	1.0	
			100	0.4	28.3	2.12	22.2	108.5	3.9	0.9	
			120	0.4	27.2	2.75	19.3	128.2	2.9	0.9	
	9	1.8	60	0.5	32.7	1.27	28.8	69.7	7.5	1.0	
			80	0.5	30.8	1.63	26.0	89.2	5.5	1.0	
			100	0.4	29.5	2.13	23.3	108.8	4.1	0.9	
			120	0.4	27.9	2.76	20.0	128.4	3.0	0.9	
70	4.5	0.5	60	0.5	35.8	1.05	32.6	70.6	10.0	1.0	
			80	0.5	30.6	1.36	26.6	89.1	6.6	1.0	
			100	0.4	32.0	1.79	26.8	109.5	5.2	0.9	
			120	0.4	30.0	2.33	23.4	129.0	3.8	0.9	
	6.75	1.0	60	0.5	37.3	1.05	34.1	71.0	10.4	1.0	
			80	0.5	34.1	1.36	30.2	90.2	7.4	1.0	
			100	0.4	33.8	1.79	28.6	110.1	5.5	0.9	
			120	0.4	31.6	2.33	25.0	129.5	4.0	0.9	
	9	1.7	60	0.5	38.6	1.05	35.5	71.4	10.8	1.0	
			80	0.5	36.6	1.36	32.6	90.9	7.9	1.0	
			100	0.4	33.9	1.80	28.7	110.1	5.5	0.9	
			120								
90	4.5	0.5	60								
			80								
			100								
			120								
	6.75	1.0	60								
			80								
			100								
			120								
	9	1.6	60								
			80								
			100								
			120								

Notes::

- 1 Antifreeze required on Load side for this operation
- 2 Interpolation is permissible. Not extrapolation
- 3 XXXXXXXXXX = Operation not recommended

HW036 Heating Performance - PART LOAD cont.

SOURCE			LOAD 9 GPM						
EWT	GPM	Pressure Drop (PSI)	EWT	Heating Capacity, MBH	Power, KW	Heat Absorb, MBH	Lvg Water Temp	COP	Pressure Drop (PSI)
30	4.5	0.6	60						
			80	18.2	1.47	14.1	84.1	3.6	1.6
			100	17.7	1.94	12.4	104.0	2.7	1.6
			120	17.0	2.54	10.3	123.8	2.0	1.5
	6.75	1.2	60						
			80	19.4	1.44	15.3	84.3	3.9	1.6
			100	18.4	1.94	13.1	104.1	2.8	1.6
			120	17.6	2.51	10.9	124.0	2.1	1.5
	9	1.9	60						
			80	20.0	1.45	15.8	84.5	4.0	1.6
			100	18.9	1.91	13.6	104.2	2.9	1.5
			120	17.9	2.55	11.0	124.0	2.1	1.5
50	4.5	0.5	60						
			80	28.6	1.59	23.9	86.4	5.3	1.6
			100	26.9	2.08	20.9	106.0	3.8	1.5
			120	26.0	2.73	18.2	125.8	2.8	1.5
	6.75	1.1	60	31.9	1.24	28.1	67.1	7.5	1.7
			80	29.7	1.59	25.0	86.6	5.5	1.6
			100	28.4	2.08	22.3	106.4	4.0	1.5
			120	27.3	2.72	19.5	126.1	2.9	1.5
	9	1.8	60	32.6	1.25	28.8	67.2	7.6	1.7
			80	30.7	1.60	26.0	86.9	5.6	1.6
			100	29.0	2.09	22.9	106.5	4.1	1.5
			120	28.0	2.73	20.2	126.3	3.0	1.5
70	4.5	0.5	60	33.7	1.04	30.5	67.5	9.5	1.7
			80	33.0	1.33	29.1	87.4	7.3	1.6
			100	31.0	1.75	26.0	106.9	5.2	1.5
			120	29.9	2.29	23.4	126.7	3.8	1.5
	6.75	1.0	60	38.6	1.02	35.5	68.6	11.1	1.7
			80	36.0	1.32	32.1	88.0	8.0	1.6
			100	33.3	1.75	28.2	107.5	5.6	1.5
			120	31.1	2.29	24.6	127.0	4.0	1.5
	9	1.7	60	39.1	1.03	36.0	68.7	11.1	1.7
			80	32.9	1.34	29.0	87.3	7.2	1.6
			100	34.6	1.76	29.5	107.8	5.8	1.5
			120						
90	4.5	0.5	60						
			80						
			100						
			120						
	6.75	1.0	60						
			80						
			100						
			120						
	9	1.6	60						
			80						
			100						
			120						

Notes::

- 1 Antifreeze required on Load side for this operation
- 2 Interpolation is permissible. Not extrapolation
- 3 [REDACTED] = Operation not recommended

HW036 heating Performance - FULL LOAD

SOURCE			LOAD							
EWT	GPM	Pressure Drop (PSI)	4.5 GPM							
			EWT	Heating Capacity, MBH	Power, KW	Heat Absorb, MBH	Lvg Water Temp	COP	Pressure Drop (PSI)	
30	4.5	0.6	60	26.9	1.60	22.1	71.9	4.9	0.5	
			80	26.0	2.03	20.0	91.6	3.8	0.5	
			100	25.2	2.56	17.8	111.3	2.9	0.4	
			120	25.3	3.22	16.1	131.4	2.3	0.4	
	6.75	1.2	60	28.5	1.63	23.5	72.6	5.1	0.5	
			80	27.3	2.06	21.3	92.2	3.9	0.5	
			100	27.2	2.61	19.6	112.2	3.1	0.4	
			120	26.5	3.26	17.1	131.9	2.4	0.4	
	9	2.0	60	29.5	1.66	24.5	73.1	5.2	0.5	
			80	28.5	2.09	22.3	92.7	4.0	0.5	
			100	27.6	2.63	20.0	112.4	3.1	0.4	
			120	27.1	3.29	17.6	132.2	2.4	0.4	
50	4.5	0.5	60	35.5	1.70	30.3	75.8	6.1	0.5	
			80	34.2	2.13	27.8	95.3	4.7	0.5	
			100	31.0	2.65	23.2	113.9	3.4	0.4	
			120	31.9	3.34	22.1	134.4	2.8	0.4	
	6.75	1.1	60	38.1	1.75	32.7	76.9	6.4	0.5	
			80	34.2	2.15	27.8	95.3	4.7	0.5	
			100	34.7	2.72	26.6	115.6	3.7	0.4	
			120	33.2	3.37	23.3	134.9	2.9	0.4	
	9	1.8	60	39.5	1.78	34.1	77.6	6.5	0.5	
			80	37.6	2.21	31.0	96.8	5.0	0.5	
			100	36.0	2.75	27.8	116.1	3.8	0.4	
			120	35.0	3.41	25.0	135.8	3.0	0.4	
70	4.5	0.5	60	44.8	1.84	39.1	79.9	7.1	0.5	
			80	39.2	2.23	32.6	97.5	5.2	0.5	
			100	41.3	2.81	32.9	118.5	4.3	0.4	
			120	39.9	3.48	29.6	138.0	3.4	0.4	
	6.75	1.0	60	48.5	1.89	42.7	81.6	7.5	0.5	
			80	43.1	2.28	36.3	99.3	5.5	0.5	
			100	44.3	2.85	35.8	119.9	4.6	0.4	
			120	42.0	3.52	31.5	138.9	3.5	0.4	
	9	1.7	60	50.6	1.93	44.7	82.5	7.7	0.5	
			80	48.0	2.34	40.8	101.4	6.0	0.5	
			100	46.0	2.88	37.3	120.6	4.7	0.4	
			120	43.7	3.55	33.1	139.7	3.6	0.4	
90	4.5	0.5	60	55.9	1.97	49.8	84.9	8.3	0.5	
			80	53.5	2.38	46.3	103.9	6.6	0.5	
			100							
			120							
	6.75	1.0	60							
			80							
			100							
			120							
	9	1.6	60							
			80							
			100							
			120							

Notes::

- 1 Antifreeze required on Load side for this operation
- 2 Interpolation is permissible. Not extrapolation
- 3 [Redacted] = Operation not recommended

HW036 Heating Performance - FULL LOAD cont.

SOURCE			LOAD							
EWT	GPM	Pressure Drop (PSI)	6.75 GPM							
			EWT	Heating Capacity, MBH	Power, KW	Heat Absorb, MBH	Lvg Water Temp	COP	Pressure Drop (PSI)	
30	4.5	0.6	60	27.1	1.54	22.4	68.0	5.1	1.0	
			80	26.2	1.97	20.4	87.8	3.9	1.0	
			100	25.7	2.50	18.5	107.7	3.0	0.9	
			120	25.0	3.16	16.0	127.5	2.3	0.9	
	6.75	1.2	60	28.7	1.57	23.9	68.5	5.4	1.0	
			80	27.9	2.00	22.0	88.3	4.1	1.0	
			100	26.5	2.52	19.2	107.9	3.1	0.9	
			120	26.5	3.20	17.3	128.0	2.4	0.9	
	9	2.0	60	29.7	1.59	24.9	68.8	5.5	1.0	
			80	28.7	2.02	22.7	88.5	4.2	1.0	
			100	27.8	2.55	20.3	108.3	3.2	0.9	
			120	27.2	3.22	17.9	128.2	2.5	0.9	
50	4.5	0.5	60	36.0	1.62	31.0	70.6	6.5	1.0	
			80	34.4	2.04	28.3	90.2	5.0	1.0	
			100	33.5	2.58	25.9	110.0	3.8	0.9	
			120	33.1	3.25	23.5	129.9	3.0	0.9	
	6.75	1.1	60	38.6	1.65	33.5	71.4	6.9	1.0	
			80	36.4	2.06	30.2	90.8	5.2	1.0	
			100	35.9	2.62	28.1	110.7	4.0	0.9	
			120	34.3	3.27	24.6	130.3	3.1	0.9	
	9	1.8	60	40.2	1.68	35.0	71.9	7.0	1.0	
			80	38.1	2.09	31.7	91.3	5.3	1.0	
			100	36.3	2.63	28.4	110.8	4.0	0.9	
			120	35.9	3.30	26.1	130.8	3.2	0.9	
70	4.5	0.5	60	45.6	1.73	40.3	73.5	7.7	1.0	
			80	44.0	2.14	37.5	93.1	6.0	1.0	
			100	41.7	2.66	33.7	112.5	4.6	0.9	
			120	40.1	3.34	30.2	132.0	3.5	0.9	
	6.75	1.0	60	49.5	1.77	44.0	74.7	8.2	1.0	
			80	47.4	2.17	40.8	94.1	6.4	1.0	
			100	45.2	2.70	37.0	113.5	4.9	0.9	
			120	43.8	3.37	33.7	133.1	3.8	0.9	
	9	1.7	60	51.8	1.81	46.2	75.3	8.4	1.0	
			80	47.7	2.18	41.0	94.2	6.4	1.0	
			100	47.9	2.73	39.7	114.3	5.1	0.9	
			120	44.5	3.39	34.3	133.4	3.8	0.9	
90	4.5	0.5	60	56.9	1.84	51.2	76.9	9.1	1.0	
			80	54.8	2.22	48.0	96.3	7.3	1.0	
			100							
			120							
	6.75	1.0	60							
			80							
			100							
			120							
	9	1.6	60							
			80							
			100							
			120							

Notes::

- 1 Antifreeze required on Load side for this operation
- 2 Interpolation is permissible. Not extrapolation
- 3 XXXXXXXXXX = Operation not recommended

HW036 Heating Performance - FULL LOAD cont.

SOURCE			LOAD 9 GPM						
EWT	GPM	Pressure Drop (PSI)	EWT	Heating Capacity, MBH	Power, KW	Heat Absorb, MBH	Lvg Water Temp	COP	Pressure Drop (PSI)
30	4.5	0.6	60						
			80	26.3	2.00	20.4	85.9	3.9	1.6
			100	25.1	2.47	18.0	105.6	3.0	1.5
			120	25.3	3.14	16.3	125.7	2.4	1.5
	6.75	1.2	60	28.8	1.54	24.1	66.4	5.5	1.7
			80	27.6	1.97	21.8	86.2	4.1	1.6
			100	26.6	2.50	19.4	106.0	3.1	1.5
			120	26.6	3.18	17.5	126.0	2.5	1.5
	9	2.0	60	29.9	1.57	25.1	66.6	5.6	1.7
			80	28.6	1.99	22.6	86.4	4.2	1.6
			100	27.7	2.56	20.1	106.2	3.2	1.6
			120	27.3	3.20	18.0	126.1	2.5	1.5
50	4.5	0.5	60	36.2	1.58	31.3	68.0	6.7	1.7
			80	34.6	2.00	28.6	87.7	5.1	1.6
			100	32.3	2.52	24.9	107.2	3.8	1.5
			120	32.5	3.22	23.0	127.3	3.0	1.5
	6.75	1.1	60	39.0	1.62	34.0	68.7	7.1	1.7
			80	37.0	2.02	30.8	88.3	5.4	1.6
			100	35.3	2.56	27.7	107.9	4.0	1.5
			120	32.2	3.21	22.8	127.3	2.9	1.5
	9	1.8	60	40.6	1.65	35.5	69.0	7.2	1.7
			80	38.1	2.05	31.9	88.5	5.5	1.6
			100	36.6	2.58	28.9	108.2	4.2	1.5
			120	35.1	3.25	25.5	127.9	3.2	1.5
70	4.5	0.5	60	46.0	1.69	40.8	70.2	8.0	1.7
			80	44.0	2.08	37.7	89.8	6.2	1.6
			100	42.6	2.62	34.7	109.5	4.8	1.5
			120	40.9	3.28	31.0	129.2	3.7	1.5
	6.75	1.0	60	50.0	1.73	44.6	71.1	8.5	1.7
			80	46.8	2.10	40.4	90.4	6.5	1.6
			100	44.9	2.63	37.0	110.1	5.0	1.5
			120	42.1	3.29	32.3	129.5	3.8	1.5
	9	1.7	60	52.4	1.76	46.9	71.6	8.7	1.7
			80	49.3	2.13	42.8	91.0	6.8	1.6
			100	44.9	2.64	36.9	110.1	5.0	1.5
			120	44.1	3.32	34.1	129.9	3.9	1.5
90	4.5	0.5	60	58.5	1.80	52.9	73.0	9.5	1.7
			80	54.5	2.14	47.9	92.2	7.5	1.6
			100						
			120						
	6.75	1.0	60						
			80						
			100						
			120						
	9	1.6	60						
			80						
			100						
			120						

Notes::

- 1 Antifreeze required on Load side for this operation
- 2 Interpolation is permissible. Not extrapolation
- 3 XXXXXXXXXX = Operation not recommended

HW036 COOLING PERFORMANCE - PART LOAD

SOURCE			LOAD 4.5 GPM						
EWT	GPM	Pressure Drop (PSI)	EWT	Cooling Capacity, MBH	Power, KW	Loop Rej/Add, MBH	Lvg Water Temp	EER	Pressure Drop (PSI)
50	4.5	0.5	50						
			60						
			70	32.5	0.90	35.3	55.6	36.1	0.5
			80	37.0	0.89	39.7	63.5	41.6	0.5
			90						
	6.75	1.1	50						
			60						
			70						
			80						
			90						
	9	1.8	50						
			60						
70									
80									
90									
70	4.5	0.5	50	22.0	1.19	25.6	40.3	18.5	0.5
			60	25.9	1.19	29.4	48.5	21.8	0.5
			70	29.9	1.19	33.5	56.7	25.3	0.5
			80	34.2	1.18	37.7	64.8	28.9	0.5
			90						
	6.75	1.0	50	22.5	1.15	25.9	40.1	19.6	0.5
			60	26.4	1.14	29.8	48.3	23.3	0.5
			70	30.6	1.12	34.0	56.4	27.3	0.5
			80	35.0	1.11	38.3	64.4	31.7	0.5
			90						
	9	1.7	50	22.7	1.14	26.0	40.0	19.9	0.5
			60	26.7	1.12	30.1	48.2	23.9	0.5
70			31.0	1.10	34.3	56.2	28.2	0.5	
80			35.5	1.08	38.7	64.2	33.0	0.5	
90									
90	4.5	0.5	50	19.6	1.64	24.3	41.3	12.0	0.5
			60	23.2	1.63	27.9	49.7	14.2	0.5
			70	27.0	1.63	31.8	58.0	16.5	0.5
			80						
			90						
	6.75	1.0	50	20.0	1.58	24.5	41.2	12.6	0.5
			60	23.7	1.56	28.3	49.5	15.2	0.5
			70	27.7	1.55	32.2	57.7	17.8	0.5
			80	31.8	1.54	36.3	65.9	20.6	0.5
			90						
	9	1.6	50	20.1	1.57	24.6	41.1	12.9	0.5
			60	24.0	1.54	28.4	49.4	15.6	0.5
70			28.0	1.52	32.4	57.6	18.4	0.5	
80			32.2	1.50	36.6	65.7	21.4	0.5	
90									
110	4.5	0.4	50	17.0	2.13	23.0	42.5	8.0	0.5
			60	20.4	2.13	26.5	51.0	9.6	0.5
			70	23.9	2.13	30.1	59.4	11.2	0.5
			80						
			90						
	6.75	0.9	50	17.3	2.08	23.2	42.4	8.3	0.5
			60	20.8	2.06	26.7	50.8	10.1	0.5
			70	24.5	2.05	30.4	59.1	12.0	0.5
			80						
			90						
	9	1.5	50	17.4	2.07	23.3	42.3	8.4	0.5
			60	21.0	2.03	26.8	50.7	10.3	0.5
70			24.7	2.01	30.5	59.0	12.3	0.5	
80									
90									

Notes::

- 1 Antifreeze required on Load side for this operation
- 2 Interpolation is permissible. Not extrapolation
- 3 XXXXXXXXXX = Operation not recommended

HW036 COOLING PERFORMANCE - PART LOAD cont.

SOURCE			LOAD 6.75 GPM						
EWT	GPM	Pressure Drop (PSI)	EWT	Cooling Capacity, MBH	Power, KW	LoopRej/Add, MBH	Lvg Water Temp	EER	Pressure Drop (PSI)
50	4.5	0.5	50						
			60						
			70	34.9	0.90	37.7	59.7	38.7	1.0
			80						
			90						
	6.75	1.1	50						
			60						
			70						
			80						
			90						
	9	1.8	50						
			60						
70									
80									
90									
70	4.5	0.5	50	23.5	1.20	27.0	43.1	19.6	1.1
			60	27.6	1.20	31.2	51.8	23.1	1.1
			70	32.0	1.19	35.6	60.5	26.9	1.0
			80						
			90						
	6.75	1.0	50	24.0	1.15	27.4	42.9	20.9	1.1
			60	28.3	1.14	31.7	51.6	24.9	1.1
			70	32.9	1.12	36.2	60.3	29.3	1.0
			80						
			90						
	9	1.7	50	24.2	1.14	27.6	42.9	21.3	1.1
			60	28.6	1.12	32.0	51.5	25.6	1.1
70			33.3	1.09	36.6	60.1	30.4	1.0	
80									
90									
90	4.5	0.5	50	20.8	1.64	25.5	43.9	12.7	1.1
			60	24.7	1.64	29.5	52.7	15.1	1.0
			70	28.8	1.64	33.6	61.5	17.5	1.0
			80						
			90						
	6.75	1.0	50	21.2	1.58	25.8	43.7	13.4	1.1
			60	25.3	1.57	29.8	52.5	16.2	1.0
			70	29.5	1.55	34.1	61.3	19.0	1.0
			80						
			90						
	9	1.6	50	21.4	1.56	25.9	43.7	13.7	1.1
			60	25.6	1.54	30.0	52.4	16.6	1.0
70			29.9	1.52	34.4	61.1	19.7	1.0	
80									
90									
110	4.5	0.4	50	18.0	2.14	24.0	44.7	8.4	1.1
			60	21.6	2.14	27.7	53.6	10.1	1.0
			70	25.4	2.14	31.6	62.5	11.9	1.0
			80						
			90						
	6.75	0.9	50	18.3	2.08	24.2	44.6	8.8	1.1
			60	22.1	2.06	28.0	53.5	10.7	1.0
			70	26.1	2.05	32.0	62.3	12.8	1.0
			80						
			90						
	9	1.5	50	18.5	2.06	24.3	44.6	9.0	1.1
			60	22.3	2.03	28.1	53.4	11.0	1.0
70			26.4	2.01	32.2	62.2	13.1	1.0	
80									
90									

Notes::

- 1 Antifreeze required on Load side for this operation
- 2 Interpolation is permissible. Not extrapolation
- 3 [Redacted] = Operation not recommended

Manufacturer reserves the right to change, at any time, specifications and designs without notice and without obligations.

HW036 COOLING PERFORMANCE - PART LOAD cont.

SOURCE			LOAD 9 GPM							
EWT	GPM	Pressure Drop (PSI)	EWT	Cooling Capacity, MBH	Power, KW	Loop Rej/Add, MBH	Lvg Water Temp	EER	Pressure Drop (PSI)	
50	4.5	0.5	50							
			60	31.4	0.93	34.3	53.0	34.0	1.8	
			70	36.3	0.91	39.1	61.9	39.9	1.7	
				80						
		6.75	1.1	50						
	60									
	70									
				80						
				90						
		9	1.8	50						
	60									
	70									
			80							
			90							
70	4.5	0.5	50	24.3	1.21	27.9	44.6	20.1	1.8	
			60	28.6	1.21	32.2	53.7	23.7	1.8	
			70	33.2	1.20	36.8	62.6	27.6	1.7	
				80						
				90						
		6.75	1.0	50	24.8	1.16	28.3	44.5	21.4	1.8
	60			29.3	1.15	32.8	53.5	25.6	1.8	
	70			34.1	1.13	37.5	62.4	30.3	1.7	
				80						
				90						
		9	1.7	50	25.1	1.15	28.5	44.5	21.9	1.8
	60			29.7	1.12	33.1	53.4	26.4	1.8	
70	34.6			1.10	37.9	62.3	31.5	1.7		
			80							
			90							
90	4.5	0.5	50	21.4	1.65	26.2	45.3	13.0	1.8	
			60	25.5	1.65	30.3	54.3	15.4	1.8	
			70	29.8	1.66	34.6	63.4	18.0	1.7	
				80						
				90						
		6.75	1.0	50	21.9	1.59	26.5	45.2	13.8	1.8
	60			26.1	1.57	30.7	54.2	16.6	1.8	
	70			30.6	1.56	35.2	63.2	19.6	1.7	
				80						
				90						
		9	1.6	50	22.1	1.57	26.7	45.1	14.1	1.8
	60			26.4	1.55	31.0	54.1	17.1	1.8	
70	31.0			1.53	35.5	63.1	20.3	1.7		
			80							
			90							
110	4.5	0.4	50	18.5	2.15	24.6	45.9	8.6	1.8	
			60	22.2	2.15	28.4	55.1	10.4	1.8	
			70	26.3	2.15	32.4	64.2	12.2	1.7	
				80						
				90						
		6.75	0.9	50	18.9	2.09	24.8	45.8	9.0	1.8
	60			22.8	2.07	28.7	55.0	11.0	1.8	
	70			26.9	2.05	32.9	64.0	13.1	1.7	
				80						
				90						
		9	1.5	50	19.0	2.07	24.9	45.8	9.2	1.8
	60			23.0	2.04	28.9	54.9	11.3	1.8	
70	27.3			2.01	33.1	63.9	13.5	1.7		
			80							
			90							

Notes::

- 1 Antifreeze required on Load side for this operation
- 2 Interpolation is permissible. Not extrapolation
- 3 [Redacted] = Operation not recommended

HW036 Cooling Performance - FULL LOAD

SOURCE			LOAD							
EWT	GPM	Pressure Drop (PSI)	4.5 GPM							
			EWT	Cooling Capacity, MBH	Power, KW	Loop Rej/Add, MBH	Lvg Water Temp	EER	Pressure Drop (PSI)	
50	4.5	0.5	50	31.9	1.47	36.4	35.9	21.6	0.6	
			60	36.6	1.54	41.4	43.8	23.7	0.5	
			70	41.7	1.61	46.7	51.5	25.9	0.5	
			80	47.0	1.68	52.3	59.1	28.1	0.5	
			90	52.6	1.75	58.1	66.5	30.1	0.5	
	6.75	1.1	50							
			60	37.4	1.46	42.0	43.4	25.7	0.5	
			70	42.7	1.52	47.5	51.1	28.2	0.5	
			80	48.3	1.57	53.3	58.5	30.7	0.5	
			90	54.2	1.64	59.4	65.9	33.0	0.5	
	9	1.8	50							
			60							
			70							
			80	49.0	1.54	53.9	58.2	31.9	0.5	
			90	54.9	1.60	60.1	65.5	34.3	0.5	
70	4.5	0.5	50	29.5	1.84	35.1	37.0	16.0	0.6	
			60	34.0	1.91	39.8	45.0	17.8	0.5	
			70	38.8	1.97	44.8	52.8	19.8	0.5	
			80	44.0	2.02	50.1	60.4	21.8	0.5	
			90	49.3	2.08	55.7	68.0	23.7	0.5	
	6.75	1.0	50	30.0	1.76	35.4	36.7	17.1	0.6	
			60	34.7	1.81	40.3	44.6	19.3	0.5	
			70	39.8	1.85	45.5	52.4	21.5	0.5	
			80	45.2	1.89	51.0	59.9	24.0	0.5	
			90	50.8	1.93	56.8	67.4	26.3	0.5	
	9	1.6	50	30.3	1.74	35.6	36.6	17.4	0.6	
			60	35.1	1.77	40.5	44.5	19.8	0.5	
			70	40.2	1.81	45.8	52.1	22.3	0.5	
			80	45.8	1.83	51.5	59.6	25.0	0.5	
			90	51.5	1.88	57.4	67.0	27.5	0.5	
90	4.5	0.4	50	26.8	2.33	33.7	38.2	11.5	0.5	
			60	31.0	2.39	38.2	46.3	13.0	0.5	
			70	35.6	2.45	43.0	54.2	14.6	0.5	
			80	40.5	2.50	48.0	62.0	16.2	0.5	
			90							
	6.75	1.0	50	27.3	2.24	34.0	38.0	12.2	0.5	
			60	31.7	2.28	38.6	46.0	13.9	0.5	
			70	36.5	2.32	43.5	53.8	15.7	0.5	
			80	41.6	2.35	48.7	61.5	17.7	0.5	
			90							
	9	1.6	50	27.3	2.26	34.1	37.9	12.1	0.5	
			60	32.0	2.24	38.8	45.8	14.3	0.5	
			70	36.9	2.27	43.7	53.6	16.3	0.5	
			80	42.1	2.28	49.1	61.3	18.5	0.5	
			90							
110	4.5	0.4	50	23.9	2.94	32.6	39.4	8.2	0.5	
			60	27.9	2.99	36.8	47.6	9.3	0.5	
			70	32.2	3.05	41.3	55.7	10.6	0.5	
			80	36.8	3.11	46.1	63.6	11.8	0.5	
			90							
	6.75	0.9	50	24.3	2.84	32.7	39.3	8.6	0.5	
			60	28.5	2.88	37.1	47.4	9.9	0.5	
			70	33.0	2.91	41.7	55.4	11.4	0.5	
			80	37.8	2.94	46.6	63.2	12.9	0.5	
			90							
	9	1.5	50	24.4	2.85	32.8	39.2	8.6	0.5	
			60	28.7	2.84	37.2	47.3	10.1	0.5	
			70	33.3	2.86	41.9	55.2	11.7	0.5	
			80	38.2	2.87	46.8	63.0	13.3	0.5	
			90							

Notes::

- 1 Antifreeze required on Load side for this operation
- 2 Interpolation is permissible. Not extrapolation
- 3 ██████████ = Operation not recommended

HW036 COOLING performance - FULL LOAD cont.

SOURCE			LOAD									
			6.75 GPM									
EWT	GPM	Pressure Drop (PSI)	EWT	Cooling Capacity, MBH	Power, KW	Loop Rej/Add, MBH	Lvg Water Temp	EER	Pressure Drop (PSI)	EER	Pressure Drop (PSI)	
50	4.5	0.5	50	34.5	1.52	39.2	39.9	22.7	1.1	23.1	1.8	
			60	39.7	1.60	44.7	48.3	24.9	1.1	25.5	1.8	
			70	45.4	1.66	50.6	56.6	27.3	1.0	28.0	1.7	
			80	51.4	1.74	56.8	64.8	29.5	1.0	30.2	1.6	
			90	[REDACTED]								
	6.75	1.1	50	[REDACTED]								
			60	40.7	1.51	45.5	48.0	27.1	1.1	27.8	1.8	
			70	46.7	1.56	51.7	56.2	29.9	1.0	30.6	1.7	
			80	53.0	1.64	58.2	64.3	32.4	1.0	33.2	1.6	
			90	[REDACTED]								
	9	1.8	50	[REDACTED]								
			60	[REDACTED]								
			70	47.4	1.53	52.3	56.0	31.0	1.0	31.8	1.7	
			80	53.9	1.60	59.0	64.0	33.7	1.0	34.5	1.6	
			90	[REDACTED]								
70	4.5	0.5	50	31.8	1.88	37.5	40.7	16.9	1.1	17.3	1.8	
			60	36.7	1.95	42.7	49.2	18.8	1.1	19.3	1.8	
			70	42.1	2.01	48.3	57.5	21.0	1.0	21.6	1.7	
			80	47.8	2.07	54.2	65.8	23.2	1.0	[REDACTED]		
			90	[REDACTED]								
	6.75	1.0	50	32.5	1.79	37.9	40.4	18.1	1.1	18.6	1.8	
			60	37.7	1.84	43.3	48.9	20.4	1.1	21.1	1.8	
			70	43.4	1.88	49.2	57.2	23.1	1.0	23.8	1.7	
			80	49.4	1.93	55.3	65.3	25.6	1.0	26.4	1.6	
			90	[REDACTED]								
	9	1.6	50	32.8	1.76	38.2	40.3	18.6	1.1	19.2	1.8	
			60	38.1	1.80	43.7	48.7	21.2	1.1	21.9	1.8	
			70	44.0	1.83	49.6	57.0	24.0	1.0	24.9	1.7	
			80	50.1	1.87	56.0	65.1	26.8	1.0	27.7	1.6	
			90	[REDACTED]								
90	4.5	0.4	50	28.7	2.37	35.8	41.5	12.2	1.1	12.4	1.8	
			60	33.4	2.43	40.7	50.1	13.8	1.1	14.1	1.8	
			70	38.4	2.49	46.0	58.6	15.5	1.0	15.9	1.7	
			80	43.8	2.54	51.6	67.0	17.3	1.0	[REDACTED]		
			90	[REDACTED]								
	6.75	1.0	50	29.3	2.27	36.1	41.4	12.9	1.1	13.3	1.8	
			60	34.2	2.31	41.2	49.9	14.8	1.1	15.3	1.8	
			70	39.5	2.34	46.7	58.3	16.9	1.0	17.5	1.7	
			80	45.2	2.37	52.5	66.6	19.1	1.0	[REDACTED]		
			90	[REDACTED]								
	9	1.6	50	29.6	2.24	36.3	41.3	13.2	1.1	13.7	1.8	
			60	34.6	2.27	41.5	49.8	15.3	1.1	15.8	1.8	
			70	40.1	2.28	47.0	58.1	17.6	1.0	18.2	1.7	
			80	45.9	2.30	53.0	66.4	19.9	1.0	[REDACTED]		
			90	[REDACTED]								
110	4.5	0.4	50	25.5	2.97	34.3	42.5	8.6	1.1	8.8	1.8	
			60	29.9	3.02	38.9	51.2	9.9	1.1	10.2	1.8	
			70	34.6	3.09	43.9	59.7	11.2	1.0	11.6	1.7	
			80	[REDACTED]								
			90	[REDACTED]								
	6.75	0.9	50	26.0	2.87	34.5	42.3	9.1	1.1	9.4	1.8	
			60	30.7	2.90	39.3	50.9	10.6	1.1	10.9	1.8	
			70	35.6	2.93	44.4	59.5	12.1	1.0	12.5	1.7	
			80	[REDACTED]								
			90	[REDACTED]								
	9	1.5	50	26.2	2.86	34.7	42.3	9.2	1.1	9.6	1.8	
			60	30.9	2.86	39.5	50.9	10.8	1.1	11.2	1.8	
			70	36.0	2.88	44.6	59.3	12.5	1.0	13.0	1.7	
			80	41.4	2.89	50.1	67.7	14.3	1.0	[REDACTED]		
			90	[REDACTED]								

Notes::

- 1 Antifreeze required on Load side for this operation
- 2 Interpolation is permissible. Not extrapolation
- 3 [REDACTED] = Operation not recommended

HW036 COOLING performance - FULL LOAD cont.

SOURCE			LOAD 9 GPM						
EWT	GPM	Pressure Drop (PSI)	EWT	Cooling Capacity, MBH	Power, KW	Loop Rej/Add, MBH	Lvg Water Temp	EER	Pressure Drop (PSI)
50	4.5	0.5	50	36.0	1.55	40.8	42.1	23.1	1.8
			60	41.5	1.63	46.7	50.8	25.5	1.8
			70	47.6	1.70	52.9	59.4	28.0	1.7
			80	53.9	1.79	59.5	68.0	30.2	1.6
			90						
	6.75	1.1	50	36.9	1.47	41.5	41.9	25.0	1.8
			60	42.7	1.54	47.6	50.5	27.8	1.8
			70	49.1	1.60	54.2	59.1	30.6	1.7
			80	55.8	1.68	61.1	67.6	33.2	1.6
			90						
	9	1.8	50						
			60						
			70	49.9	1.57	54.9	58.9	31.8	1.7
			80	56.8	1.65	62.0	67.4	34.5	1.6
			90						
70	4.5	0.5	50	33.0	1.91	38.9	42.7	17.3	1.8
			60	38.3	1.98	44.4	51.5	19.3	1.8
			70	44.1	2.04	50.3	60.2	21.6	1.7
			80						
			90						
	6.75	1.0	50	33.9	1.82	39.4	42.5	18.6	1.8
			60	39.4	1.87	45.1	51.3	21.1	1.8
			70	45.5	1.91	51.4	59.9	23.8	1.7
			80	51.8	1.96	57.9	68.5	26.4	1.6
			90						
	9	1.6	50	34.2	1.78	39.7	42.4	19.2	1.8
			60	39.9	1.82	45.6	51.2	21.9	1.8
			70	46.2	1.86	51.9	59.7	24.9	1.7
			80	52.7	1.91	58.7	68.3	27.7	1.6
			90						
90	4.5	0.4	50	29.8	2.40	37.0	43.4	12.4	1.8
			60	34.8	2.46	42.2	52.3	14.1	1.8
			70	40.1	2.52	47.7	61.1	15.9	1.7
			80						
			90						
	6.75	1.0	50	30.5	2.29	37.4	43.3	13.3	1.8
			60	35.7	2.33	42.7	52.1	15.3	1.8
			70	41.3	2.36	48.5	60.8	17.5	1.7
			80						
			90						
	9	1.6	50	30.8	2.26	37.6	43.2	13.7	1.8
			60	36.1	2.28	43.0	52.0	15.8	1.8
			70	41.9	2.30	49.0	60.7	18.2	1.7
			80						
			90						
110	4.5	0.4	50	26.4	2.99	35.3	44.2	8.8	1.8
			60	31.0	3.05	40.2	53.1	10.2	1.8
			70	36.0	3.12	45.3	62.0	11.6	1.7
			80						
			90						
	6.75	0.9	50	27.0	2.89	35.6	44.0	9.4	1.8
			60	31.8	2.92	40.6	52.9	10.9	1.8
			70	37.1	2.95	46.0	61.8	12.5	1.7
			80						
			90						
	9	1.5	50	27.3	2.85	35.7	44.0	9.6	1.8
			60	32.2	2.87	40.8	52.9	11.2	1.8
			70	37.5	2.89	46.3	61.7	13.0	1.7
			80						
			90						

Notes::

- 1 Antifreeze required on Load side for this operation
- 2 Interpolation is permissible. Not extrapolation
- 3 XXXXXXXXXX = Operation not recommended

HW048 Heating Performance - PART LOAD

SOURCE			LOAD 6 GPM						
EWT	GPM	Pressure Drop (PSI)	EWT	Heating Capacity, MBH	Power, KW	Heat Absorb, MBH	Lvg Water Temp	COP	Pressure Drop (PSI)
30	6	0.9	60						
			80	25.4	1.93	19.9	88.5	3.9	0.7
			100	23.2	2.50	16.4	107.8	2.7	0.7
			120	21.3	3.25	12.7	127.2	1.9	0.6
	9	1.9	60						
			80	26.4	1.94	20.8	88.8	4.0	0.7
			100	24.0	2.52	17.1	108.1	2.8	0.7
			120	21.9	3.27	13.2	127.4	2.0	0.6
	12	3.1	60						
			80	26.9	1.97	21.3	89.0	4.0	0.7
			100	24.4	2.55	17.4	108.2	2.8	0.7
			120	22.2	3.30	13.4	127.5	2.0	0.6
50	6	0.8	60	36.0	1.44	31.6	72.0	7.3	0.8
			80	33.4	1.90	27.9	91.2	5.2	0.7
			100	31.1	2.48	24.0	110.4	3.7	0.7
			120	29.0	3.23	20.0	129.8	2.6	0.6
	9	1.7	60	37.8	1.45	33.4	72.6	7.6	0.8
			80	35.0	1.91	29.4	91.7	5.4	0.7
			100	32.3	2.50	25.2	110.9	3.8	0.7
			120	30.0	3.24	20.9	130.1	2.7	0.6
	12	2.9	60	38.8	1.47	34.4	72.9	7.7	0.8
			80	35.8	1.93	30.2	92.0	5.4	0.7
			100	33.0	2.52	25.8	111.1	3.8	0.7
			120	30.5	3.27	21.3	130.3	2.7	0.6
70	6	0.8	60	44.6	1.35	40.6	74.9	9.7	0.8
			80	41.7	1.82	36.4	94.0	6.7	0.7
			100	39.1	2.40	32.2	113.1	4.8	0.7
			120	36.7	3.13	27.8	132.4	3.4	0.6
	9	1.6	60	47.0	1.35	43.0	75.7	10.2	0.8
			80	43.8	1.82	38.5	94.7	7.1	0.7
			100	40.8	2.41	33.9	113.7	5.0	0.7
			120						
	12	2.7	60	48.4	1.36	44.3	76.1	10.4	0.8
			80						
			100						
			120						
90	6	0.7	60						
			80						
			100						
			120						
	9	1.5	60						
			80						
			100						
			120						
	12	2.5	60						
			80						
			100						
			120						

Notes::

- 1 Antifreeze required on Load side for this operation
- 2 Interpolation is permissible. Not extrapolation
- 3 [Redacted] = Operation not recommended

HW048 Heating Performance - PART LOAD cont.

SOURCE			LOAD 9 GPM						
EWT	GPM	Pressure Drop (PSI)	EWT	Heating Capacity, MBH	Power, KW	Heat Absorb, MBH	Lvg Water Temp	COP	Pressure Drop (PSI)
30	6	0.9	60						
			80	25.7	1.88	20.3	85.7	4.0	1.5
			100	23.5	2.46	16.7	105.3	2.8	1.4
			120	21.5	3.21	13.0	124.8	2.0	1.4
	9	1.9	60						
			80	26.7	1.90	21.3	86.0	4.1	1.5
			100	24.3	2.47	17.4	105.4	2.9	1.4
			120	22.1	3.22	13.5	125.0	2.0	1.4
	12	3.1	60						
			80	27.3	1.92	21.8	86.1	4.2	1.5
			100	24.7	2.50	17.8	105.5	2.9	1.4
			120	22.4	3.25	13.7	125.0	2.0	1.4
50	6	0.8	60						
			80	33.9	1.83	28.6	87.6	5.4	1.5
			100	31.4	2.41	24.6	107.0	3.8	1.4
			120	29.2	3.16	20.4	126.6	2.7	1.4
	9	1.7	60						
			80	35.5	1.83	30.1	87.9	5.7	1.5
			100	32.7	2.42	25.8	107.3	4.0	1.4
			120	30.2	3.17	21.3	126.8	2.8	1.4
	12	2.9	60						
			80	36.4	1.86	30.9	88.1	5.7	1.5
			100	33.4	2.44	26.4	107.5	4.0	1.4
			120	30.8	3.19	21.8	126.9	2.8	1.4
70	6	0.8	60	45.4	1.26	41.5	70.1	10.5	1.6
			80	42.4	1.72	37.3	89.5	7.2	1.5
			100	39.6	2.30	32.9	108.9	5.0	1.4
			120	37.1	3.03	28.4	128.3	3.6	1.4
	9	1.6	60	47.9	1.25	44.1	70.6	11.2	1.6
			80	44.6	1.72	39.5	89.9	7.6	1.5
			100	41.4	2.30	34.7	109.3	5.3	1.4
			120						
	12	2.7	60	49.3	1.27	45.5	71.0	11.4	1.6
			80	45.8	1.74	40.7	90.2	7.7	1.5
			100						
			120						
90	6	0.7	60						
			80						
			100						
			120						
	9	1.5	60						
			80						
			100						
			120						
	12	2.5	60						
			80						
			100						
			120						

Notes::

- 1 Antifreeze required on Load side for this operation
- 2 Interpolation is permissible. Not extrapolation
- 3 XXXXXXXXXX = Operation not recommended

HW048 Heating Performance - PART LOAD cont.

SOURCE			LOAD							
EWT	GPM	Pressure Drop (PSI)	12 GPM							
			EWT	Heating Capacity, MBH	Power, KW	Heat Absorb, MBH	Lvg Water Temp	COP	Pressure Drop (PSI)	
30	6	0.9	60							
			80	25.9	1.88	20.6	84.3	4.0	2.6	
			100	23.6	2.45	16.9	104.0	2.8	2.4	
			120	21.6	3.21	13.1	123.6	2.0	2.3	
	9	1.9	60							
			80	27.0	1.89	21.5	84.5	4.2	2.6	
			100	24.5	2.46	17.6	104.1	2.9	2.4	
			120	22.2	3.22	13.6	123.7	2.0	2.3	
	12	3.1	60							
			80	27.5	1.92	22.0	84.6	4.2	2.6	
			100	24.9	2.49	18.0	104.2	2.9	2.4	
			120	22.6	3.25	13.8	123.8	2.0	2.3	
50	6	0.8	60							
			80	34.2	1.81	28.9	85.7	5.5	2.6	
			100	31.6	2.39	24.8	105.3	3.9	2.4	
			120	29.4	3.14	20.6	125.0	2.7	2.3	
	9	1.7	60							
			80	35.8	1.82	30.5	86.0	5.8	2.6	
			100	33.0	2.39	26.1	105.5	4.0	2.4	
			120	30.4	3.15	21.6	125.1	2.8	2.3	
	12	2.9	60							
			80	36.7	1.84	31.3	86.1	5.9	2.6	
			100	33.7	2.42	26.7	105.7	4.1	2.4	
			120	31.0	3.17	22.0	125.2	2.9	2.3	
70	6	0.8	60	45.8	1.24	42.0	67.6	10.8	2.7	
			80	42.8	1.69	37.8	87.2	7.4	2.6	
			100	39.9	2.27	33.3	106.7	5.2	2.4	
			120	37.3	2.99	28.8	126.3	3.7	2.3	
	9	1.6	60	48.4	1.23	44.7	68.1	11.6	2.7	
			80	45.0	1.69	40.0	87.5	7.8	2.6	
			100	41.7	2.27	35.2	107.0	5.4	2.4	
			120							
	12	2.7	60	49.9	1.24	46.1	68.3	11.8	2.7	
			80	46.2	1.70	41.2	87.7	8.0	2.6	
			100							
			120							
90	6	0.7	60							
			80							
			100							
			120							
	9	1.5	60							
			80							
			100							
			120							
	12	2.5	60							
			80							
			100							
			120							

Notes::

- 1 Antifreeze required on Load side for this operation
- 2 Interpolation is permissible. Not extrapolation
- 3 XXXXXXXXXX = Operation not recommended

HW048 Heating Performance - FULL LOAD

SOURCE			LOAD 6 GPM						
EWT	GPM	Pressure Drop (PSI)	EWT	Heating Capacity, MBH	Power, KW	Heat Absorb, MBH	Lvg Water Temp	COP	Pressure Drop (PSI)
30	6	0.9	60	35.9	2.02	29.8	71.9	5.2	0.8
			80	34.6	2.60	27.0	91.6	3.9	0.7
			100	33.5	3.31	23.9	111.3	3.0	0.7
			120	32.7	4.22	20.6	131.0	2.3	0.6
	9	1.9	60	38.0	2.07	31.7	72.7	5.4	0.8
			80	36.4	2.64	28.5	92.2	4.0	0.7
			100	34.9	3.35	25.2	111.7	3.1	0.7
			120	33.8	4.26	21.5	131.4	2.3	0.6
	12	3.1	60	39.2	2.12	32.7	73.1	5.4	0.8
			80	37.4	2.69	29.4	92.5	4.1	0.7
			100	35.7	3.39	25.8	112.0	3.1	0.7
			120	34.4	4.30	22.0	131.6	2.3	0.6
50	6	0.9	60	45.8	2.15	39.2	75.3	6.3	0.8
			80	44.1	2.69	36.0	94.8	4.8	0.7
			100	42.5	3.38	32.5	114.3	3.7	0.7
			120	41.2	4.27	28.7	133.9	2.8	0.6
	9	1.7	60	48.8	2.20	42.1	76.3	6.5	0.8
			80	46.6	2.74	38.4	95.6	5.0	0.7
			100	44.6	3.43	34.4	115.0	3.8	0.7
			120	42.9	4.31	30.2	134.5	2.9	0.6
	12	2.9	60	50.5	2.26	43.6	76.8	6.6	0.8
			80	48.0	2.79	39.6	96.1	5.0	0.7
			100	45.7	3.47	35.4	115.4	3.9	0.7
			120	43.8	4.35	31.0	134.8	3.0	0.6
70	6	0.8	60	57.5	2.26	50.6	79.2	7.5	0.8
			80	55.2	2.79	46.8	98.5	5.8	0.7
			100	53.0	3.48	42.5	117.8	4.5	0.7
			120	51.1	4.38	38.1	137.3	3.4	0.6
	9	1.6	60	61.5	2.30	54.4	80.5	7.8	0.8
			80	58.6	2.83	50.0	99.6	6.1	0.7
			100	55.9	3.53	45.2	118.8	4.6	0.7
			120	53.5	4.44	40.3	138.1	3.5	0.6
	12	2.7	60	63.7	2.34	56.5	81.2	8.0	0.8
			80	60.5	2.87	51.7	100.3	6.2	0.7
			100	57.5	3.58	46.7	119.3	4.7	0.7
			120	54.8	4.48	41.4	138.5	3.6	0.6
90	6	0.7							
	9	1.5							
	12	2.5							

Notes::

- 1 Antifreeze required on Load side for this operation
- 2 Interpolation is permissible. Not extrapolation
- 3 XXXXXXXXXX = Operation not recommended

HW048 Heating Performance - FULL LOAD cont.

SOURCE			LOAD 9 GPM						
EWT	GPM	Pressure Drop (PSI)	EWT	Heating Capacity, MBH	Power, KW	Heat Absorb, MBH	Lvg Water Temp	COP	Pressure Drop (PSI)
30	6	0.9	60						
			80	34.9	2.52	27.4	87.8	4.1	1.5
			100	33.7	3.21	24.3	107.6	3.1	1.4
			120	32.8	4.13	20.9	127.4	2.3	1.4
	9	1.9	60						
			80	36.7	2.55	29.1	88.2	4.2	1.5
			100	35.2	3.25	25.7	107.9	3.2	1.4
			120	33.9	4.16	21.9	127.6	2.4	1.4
	12	3.1	60						
			80	37.7	2.59	30.0	88.4	4.3	1.5
			100	36.0	3.28	26.3	108.1	3.2	1.4
			120	34.6	4.19	22.4	127.8	2.4	1.4
50	6	0.9	60	46.2	2.04	39.9	70.3	6.6	1.6
			80	44.5	2.58	36.8	89.9	5.1	1.5
			100	42.8	3.26	33.2	109.6	3.9	1.4
			120	41.4	4.14	29.2	129.3	2.9	1.4
	9	1.7	60	49.4	2.10	43.0	71.0	6.9	1.6
			80	47.2	2.62	39.2	90.5	5.3	1.5
			100	45.0	3.30	35.2	110.1	4.0	1.4
			120	43.2	4.17	30.9	129.7	3.0	1.4
	12	2.9	60	51.3	2.14	44.6	71.4	7.0	1.6
			80	48.7	2.67	40.6	90.9	5.4	1.5
			100	46.2	3.34	36.2	110.4	4.1	1.4
			120	44.2	4.21	31.7	129.9	3.1	1.4
70	6	0.8	60	58.2	2.13	51.6	72.9	8.0	1.6
			80	55.9	2.65	47.8	92.5	6.2	1.5
			100	53.5	3.32	43.6	112.0	4.7	1.4
			120	51.5	4.20	39.0	131.6	3.6	1.4
	9	1.6	60	63.0	2.16	56.3	74.0	8.5	1.6
			80	59.5	2.67	51.3	93.3	6.5	1.5
			100	56.6	3.35	46.5	112.7	5.0	1.4
			120	54.0	4.24	41.3	132.2	3.7	1.4
	12	2.7	60	64.9	2.19	58.0	74.4	8.7	1.6
			80	61.5	2.71	53.2	93.7	6.7	1.5
			100	58.2	3.38	48.0	113.1	5.0	1.4
			120	55.4	4.28	42.6	132.5	3.8	1.4
90	6	0.7							
	9	1.5							
	12	2.5							

Notes::

- 1 Antifreeze required on Load side for this operation
- 2 Interpolation is permissible. Not extrapolation
- 3 XXXXXXXXXX = Operation not recommended

HW048 Heating Performance - FULL LOAD cont.

SOURCE			LOAD 12 GPM						
EWT	GPM	Pressure Drop (PSI)	EWT	Heating Capacity, MBH	Power, KW	Heat Absorb, MBH	Lvg Water Temp	COP	Pressure Drop (PSI)
30	6	0.9	60						
			80	35.1	2.49	27.7	85.9	4.1	2.6
			100	33.9	3.19	24.6	105.7	3.1	2.4
			120	32.9	4.09	21.1	125.6	2.4	2.3
	9	1.9	60						
			80	36.9	2.52	29.4	86.2	4.3	2.6
			100	35.4	3.21	25.9	105.9	3.2	2.4
			120	34.1	4.12	22.1	125.7	2.4	2.3
	12	3.1	60						
			80	38.0	2.56	30.3	86.4	4.3	2.6
			100	36.2	3.25	26.6	106.1	3.3	2.4
			120	34.7	4.16	22.6	125.9	2.5	2.3
50	6	0.9	60	46.5	2.01	40.3	67.7	6.8	2.7
			80	44.8	2.54	37.1	87.5	5.2	2.6
			100	43.1	3.21	33.5	107.2	3.9	2.4
			120	41.6	4.08	29.5	127.0	3.0	2.3
	9	1.7	60	49.8	2.06	43.4	68.3	7.1	2.7
			80	47.5	2.58	39.7	88.0	5.4	2.6
			100	45.3	3.25	35.6	107.6	4.1	2.4
			120	43.4	4.11	31.2	127.3	3.1	2.3
	12	2.9	60	51.7	2.10	45.1	68.6	7.2	2.7
			80	49.1	2.62	41.1	88.2	5.5	2.6
			100	46.5	3.29	36.7	107.8	4.2	2.4
			120	44.4	4.15	32.1	127.5	3.1	2.3
70	6	0.8	60	58.6	2.08	52.2	69.8	8.3	2.7
			80	56.3	2.59	48.4	89.4	6.4	2.5
			100	53.9	3.25	44.1	109.1	4.9	2.4
			120	51.7	4.12	39.4	128.7	3.7	2.3
	9	1.6	60	63.0	2.11	56.4	70.5	8.8	2.7
			80	60.0	2.61	52.0	90.0	6.7	2.5
			100	57.0	3.27	47.1	109.6	5.1	2.4
			120	54.3	4.16	41.9	129.2	3.8	2.3
	12	2.7	60	65.6	2.14	58.9	70.9	9.0	2.7
			80	62.1	2.64	54.0	90.4	6.9	2.5
			100	58.7	3.31	48.7	109.9	5.2	2.4
			120	55.8	4.20	43.2	129.4	3.9	2.3
90	6	0.7							
	9	1.5							
	12	2.5							

Notes::

- 1 Antifreeze required on Load side for this operation
- 2 Interpolation is permissible. Not extrapolation
- 3 [Redacted] = Operation not recommended

HW048 Cooling Performance - PART LOAD

SOURCE			LOAD 6 GPM						
EWT	GPM	Pressure Drop (PSI)	EWT	Cooling Capacity, MBH	Power, KW	Loop Rej/Add, MBH	Lvg Water Temp	EER	Pressure Drop (PSI)
50	6	0.8	50						
			60						
			70						
			80	49.6	1.06	52.8	63.5	46.7	0.8
			90						
	9	1.7	50						
			60						
			70						
			80						
			90						
	12	2.8	50						
			60						
			70						
			80						
			90						
70	6	0.8	50	29.2	1.57	33.9	40.3	18.6	0.9
			60	34.0	1.56	38.6	48.7	21.9	0.8
			70	40.0	1.53	44.6	56.7	26.1	0.8
			80	44.7	1.51	49.2	65.1	29.7	0.8
			90						
	9	1.6	50	30.0	1.51	34.5	40.1	19.8	0.9
			60	35.0	1.48	39.5	48.4	23.6	0.8
			70	40.6	1.45	44.9	56.5	28.0	0.8
			80						
			90						
	12	2.6	50	30.6	1.50	35.1	39.9	20.4	0.9
			60	34.7	1.47	39.1	48.5	23.6	0.8
			70	40.3	1.43	44.6	56.6	28.3	0.8
			80	47.1	1.36	51.2	64.3	34.5	0.8
			90						
90	6	0.7	50	25.8	2.15	32.0	41.5	12.0	0.8
			60	30.3	2.14	36.6	49.9	14.2	0.8
			70	35.2	2.13	41.4	58.3	16.5	0.8
			80						
			90						
	9	1.5	50	26.3	2.08	32.3	41.3	12.6	0.8
			60	30.9	2.06	36.9	49.7	15.0	0.8
			70	36.3	2.03	42.2	57.9	17.9	0.8
			80						
			90						
	12	2.5	50	26.5	2.07	32.5	41.2	12.9	0.8
			60	31.3	2.03	37.3	49.6	15.4	0.8
			70	36.4	2.00	42.3	57.9	18.3	0.8
			80						
			90						
110	6	0.7	50	22.0	2.81	30.0	42.7	7.8	0.8
			60	26.4	2.80	34.4	51.2	9.4	0.8
			70	31.1	2.78	39.2	59.6	11.2	0.8
			80						
			90						
	9	1.4	50	22.5	2.73	30.2	42.6	8.2	0.8
			60	27.0	2.71	34.8	51.0	10.0	0.8
			70	31.9	2.67	39.7	59.4	12.0	0.8
			80						
			90						
	12	2.3	50	22.7	2.71	30.4	42.5	8.4	0.8
			60	27.3	2.68	35.0	50.9	10.2	0.8
			70	32.2	2.64	39.9	59.3	12.2	0.8
			80						
			90						

Notes::

- 1 Antifreeze required on Load side for this operation
- 2 Interpolation is permissible. Not extrapolation
- 3 XXXXXXXXXX = Operation not recommended

HW048 Cooling Performance - PART LOAD cont.

SOURCE			LOAD 9 GPM						
EWT	GPM	Pressure Drop (PSI)	EWT	Cooling Capacity, MBH	Power, KW	Loop Rej/Add, MBH	Lvg Water Temp	EER	Pressure Drop (PSI)
50	6	0.8	50						
			60						
			70						
			80						
			90						
	9	1.7	50						
			60						
			70						
			80						
			90						
	12	2.8	50						
			60						
70									
80									
90									
70	6	0.8	50	30.2	1.58	34.9	43.3	19.1	1.7
			60	36.3	1.56	40.9	52.0	23.2	1.6
			70	42.1	1.54	46.7	60.6	27.4	1.6
			80						
			90						
	9	1.6	50	31.9	1.52	36.4	43.0	21.0	1.7
			60	36.4	1.49	40.8	51.9	24.5	1.6
			70	40.7	1.45	45.1	61.0	28.0	1.6
			80						
			90						
	12	2.6	50	31.9	1.51	36.4	43.0	21.2	1.7
			60	37.5	1.46	41.9	51.7	25.7	1.7
70			43.4	1.42	47.7	60.4	30.6	1.6	
80									
90									
90	6	0.7	50	27.2	2.17	33.4	44.0	12.5	1.7
			60	32.1	2.15	38.3	52.9	14.9	1.6
			70	37.3	2.14	43.5	61.7	17.4	1.6
			80						
			90						
	9	1.5	50	27.8	2.09	33.9	43.9	13.3	1.7
			60	32.8	2.06	38.8	52.7	15.9	1.6
			70	38.1	2.03	44.0	61.5	18.8	1.6
			80						
			90						
	12	2.5	50	28.1	2.07	34.1	43.8	13.6	1.7
			60	33.2	2.03	39.1	52.7	16.3	1.6
70			38.7	1.99	44.6	61.4	19.4	1.6	
80									
90									
110	6	0.7	50	23.1	2.82	31.1	44.9	8.2	1.7
			60	27.7	2.81	35.8	53.9	9.9	1.6
			70	32.8	2.78	40.9	62.7	11.8	1.6
			80						
			90						
	9	1.4	50	23.6	2.74	31.4	44.8	8.6	1.7
			60	28.4	2.72	36.2	53.7	10.5	1.6
			70	33.7	2.67	41.4	62.5	12.6	1.6
			80						
			90						
	12	2.3	50	23.9	2.72	31.6	44.7	8.8	1.7
			60	28.8	2.68	36.5	53.6	10.7	1.6
70			34.1	2.63	41.7	62.4	13.0	1.6	
80									
90									

Notes::

- 1 Antifreeze required on Load side for this operation
- 2 Interpolation is permissible. Not extrapolation
- 3 XXXXXXXXXX = Operation not recommended

HW048 Cooling Performance - PART LOAD cont.

SOURCE			LOAD 12 GPM						
EWT	GPM	Pressure Drop (PSI)	EWT	Cooling Capacity, MBH	Power, KW	Loop Rej/Add, MBH	Lvg Water Temp	EER	Pressure Drop (PSI)
50	6	0.8	50						
			60						
			70	47.4	1.12	50.9	62.1	42.2	2.7
			80						
	9	1.7	50						
			60						
			70						
			80						
	12	2.8	50						
			60						
			70						
			80						
70	6	0.8	50	31.7	1.61	36.5	44.7	19.7	2.9
			60	37.1	1.59	41.9	53.8	23.4	2.8
			70	42.7	1.56	47.4	62.9	27.3	2.7
			80						
	9	1.6	50	32.4	1.54	37.1	44.6	21.1	2.9
			60	38.4	1.50	43.0	53.6	25.6	2.8
			70	43.5	1.46	47.9	62.8	29.7	2.7
			80						
	12	2.6	50	32.9	1.53	37.5	44.5	21.6	2.9
			60	39.1	1.48	43.5	53.5	26.4	2.8
			70	44.6	1.43	49.0	62.6	31.2	2.7
			80						
90	6	0.7	50	27.9	2.19	34.2	45.4	12.7	2.9
			60	33.0	2.18	39.3	54.5	15.1	2.8
			70	38.4	2.16	44.7	63.6	17.8	2.7
			80						
	9	1.5	50	28.5	2.11	34.7	45.3	13.5	2.9
			60	33.8	2.08	39.9	54.4	16.2	2.8
			70	39.4	2.05	45.4	63.4	19.2	2.7
			80						
	12	2.5	50	28.9	2.09	35.0	45.2	13.8	2.9
			60	34.2	2.05	40.2	54.3	16.7	2.8
			70	39.8	2.01	45.8	63.4	19.8	2.7
			80						
110	6	0.7	50	23.6	2.85	31.7	46.1	8.3	2.9
			60	28.4	2.84	36.6	55.3	10.0	2.8
			70						
			80						
	9	1.4	50	24.2	2.77	32.1	46.0	8.7	2.9
			60	29.1	2.74	37.0	55.2	10.7	2.8
			70						
			80						
	12	2.3	50	24.5	2.74	32.3	45.9	8.9	2.9
			60	29.5	2.70	37.3	55.1	10.9	2.8
			70						
			80						

- Notes::
- 1 Antifreeze required on Load side for this operation
 - 2 Interpolation is permissible. Not extrapolation
 - 3 [Redacted] = Operation not recommended

HW048 Cooling Performance - FULL LOAD

SOURCE			LOAD 6 GPM							
EWT	GPM	Pressure Drop (PSI)	EWT	Cooling Capacity, MBH	Power, KW	Loop Rej/Add, MBH	Lvg Water Temp	EER	Pressure Drop (PSI)	
50	6	0.8	50							
			60	47.2	1.96	53.4	44.3	24.1	0.8	
			70	54.0	2.02	60.3	52.0	26.7	0.8	
			80	61.0	2.08	67.5	59.7	29.4	0.8	
			90	68.0	2.12	74.6	67.3	32.1	0.7	
	9	1.7	50							
			60							
			70							
			80							
			90	70.2	1.96	76.4	66.5	35.8	0.7	
	12	2.8	50							
			60							
			70							
			80							
			90							
70	6	0.7	50	37.9	2.39	45.2	37.5	15.9	0.9	
			60	43.8	2.47	51.3	45.5	17.7	0.8	
			70	50.2	2.52	57.9	53.3	19.9	0.8	
			80	56.8	2.58	64.7	61.0	22.1	0.8	
			90							
	9	1.6	50	38.7	2.28	45.7	37.2	17.0	0.9	
			60	44.8	2.35	52.0	45.1	19.1	0.8	
			70	51.5	2.38	58.8	52.9	21.6	0.8	
			80	58.5	2.41	66.0	60.5	24.3	0.8	
			90	64.6	2.44	72.2	68.4	26.5	0.7	
	12	2.6	50	39.1	2.25	46.1	37.0	17.4	0.9	
			60	45.3	2.31	52.5	44.9	19.7	0.8	
			70	52.1	2.33	59.4	52.6	22.4	0.8	
			80	59.4	2.35	66.7	60.2	25.2	0.8	
			90	66.9	2.37	74.3	67.6	28.2	0.7	
90	6	0.7	50	34.1	3.01	43.1	38.7	11.3	0.9	
			60	39.7	3.09	49.0	46.8	12.8	0.8	
			70	45.4	3.15	54.9	54.9	14.4	0.8	
			80	51.9	3.22	61.7	62.7	16.1	0.8	
			90							
	9	1.5	50	34.9	2.89	43.6	38.5	12.1	0.9	
			60	40.6	2.96	49.5	46.5	13.7	0.8	
			70	46.9	2.99	56.0	54.4	15.7	0.8	
			80	53.8	3.03	63.1	62.0	17.8	0.8	
			90							
	12	2.5	50	35.2	2.85	43.8	38.3	12.4	0.9	
			60	41.1	2.91	49.9	46.4	14.1	0.8	
			70	47.6	2.93	56.5	54.2	16.3	0.8	
			80	54.3	2.95	63.3	61.9	18.4	0.8	
			90							
110	6	0.7	50	30.2	3.77	41.4	40.0	8.0	0.8	
			60	35.5	3.87	47.1	48.2	9.2	0.8	
			70	41.5	3.96	53.4	56.2	10.5	0.8	
			80	47.4	4.05	59.7	64.2	11.7	0.8	
			90							
	9	1.4	50	30.9	3.67	41.8	39.8	8.4	0.9	
			60	36.3	3.71	47.4	47.9	9.8	0.8	
			70	42.1	3.76	53.4	56.0	11.2	0.8	
			80	48.1	3.82	59.7	64.0	12.6	0.8	
			90							
	12	2.3	50	31.2	3.63	41.9	39.7	8.6	0.9	
			60	36.7	3.65	47.7	47.8	10.1	0.8	
			70	42.7	3.69	53.9	55.8	11.6	0.8	
			80	49.4	3.73	60.7	63.5	13.2	0.8	
			90							

Notes::

- 1 Antifreeze required on Load side for this operation
- 2 Interpolation is permissible. Not extrapolation
- 3 XXXXXXXXXX = Operation not recommended

HW048 Cooling Performance - FULL LOAD cont.

SOURCE			LOAD 9 GPM						
EWT	GPM	Pressure Drop (PSI)	EWT	Cooling Capacity, MBH	Power, KW	Loop Rej/Add, MBH	Lvg Water Temp	EER	Pressure Drop (PSI)
50	6	0.8	50						
			60	51.1	2.01	57.4	48.7	25.4	1.7
			70	58.5	2.07	65.0	57.0	28.2	1.6
			80	66.2	2.13	72.9	65.3	31.2	1.6
	9	1.7	50						
			60						
			70						
			80	68.3	1.97	74.6	64.8	34.7	1.6
	12	2.8	50						
			60						
			70						
			80						
70	6	0.7	50	40.6	2.44	48.1	41.0	16.6	1.7
			60	47.1	2.51	54.8	49.6	18.8	1.7
			70	54.2	2.57	62.2	58.0	21.1	1.6
			80	61.6	2.63	69.8	66.3	23.5	1.6
	9	1.6	50	41.6	2.33	48.8	40.8	17.9	1.7
			60	48.4	2.38	55.8	49.3	20.3	1.7
			70	55.8	2.42	63.3	57.6	23.1	1.6
			80	63.7	2.45	71.3	65.8	26.0	1.6
	12	2.6	50	42.1	2.29	49.2	40.7	18.4	1.7
			60	49.1	2.33	56.3	49.1	21.0	1.7
			70	56.7	2.36	64.0	57.4	24.0	1.6
			80	64.7	2.38	72.1	65.6	27.2	1.6
90	6	0.7	50	36.4	3.06	45.6	42.0	11.9	1.7
			60	42.5	3.14	52.0	50.6	13.5	1.7
			70	49.2	3.21	58.9	59.1	15.3	1.6
			80	56.1	3.28	66.1	67.5	17.1	1.6
	9	1.5	50	37.3	2.94	46.1	41.8	12.7	1.7
			60	43.6	2.99	52.7	50.3	14.6	1.7
			70	50.7	3.02	59.9	58.7	16.8	1.6
			80	58.0	3.06	67.3	67.1	18.9	1.6
	12	2.5	50	37.8	2.89	46.5	41.7	13.1	1.7
			60	44.2	2.93	53.2	50.2	15.1	1.7
			70	51.4	2.95	60.5	58.6	17.4	1.6
			80	58.9	2.98	68.1	66.9	19.8	1.6
110	6	0.7	50	32.2	3.84	43.6	42.9	8.4	1.7
			60	37.8	3.92	49.6	51.6	9.7	1.6
			70	43.7	4.00	55.8	60.3	10.9	1.6
			80						
	9	1.4	50	32.8	3.70	43.8	42.8	8.9	1.7
			60	38.9	3.75	50.1	51.4	10.4	1.6
			70	45.2	3.81	56.7	60.0	11.9	1.6
			80						
	12	2.3	50	33.2	3.65	44.1	42.7	9.1	1.7
			60	39.3	3.69	50.4	51.3	10.7	1.6
			70	43.3	3.71	54.5	60.4	11.7	1.6
			80						

- Notes::
- 1 Antifreeze required on Load side for this operation
 - 2 Interpolation is permissible. Not extrapolation
 - 3 [Redacted] = Operation not recommended

HW048 Cooling Performance - FULL LOAD cont.

SOURCE			LOAD 12 GPM							
EWT	GPM	Pressure Drop (PSI)	EWT	Cooling Capacity, MBH	Power, KW	Loop Rej/Add, MBH	Lvg Water Temp	EER	Pressure Drop (PSI)	
50	6	0.8	50	45.9	1.99	52.1	42.4	23.1	2.9	
			60	53.2	2.06	59.7	51.2	25.9	2.8	
			70	61.1	2.12	67.7	59.8	28.8	2.7	
			80	69.3	2.17	76.1	68.4	32.0	2.6	
	9	1.7	50							
			60							
			70							
			80	71.6	2.00	78.0	68.0	35.8	2.6	
	12	2.8	50							
			60							
			70							
			80							
70	6	0.7	50	42.1	2.49	49.7	43.0	16.9	2.9	
			60	49.0	2.56	56.9	51.9	19.2	2.8	
			70	56.5	2.62	64.6	60.6	21.6	2.7	
			80							
	9	1.6	50	43.2	2.38	50.5	42.8	18.2	2.9	
			60	50.5	2.42	58.0	51.6	20.9	2.8	
			70	58.3	2.45	65.9	60.3	23.8	2.7	
			80							
	12	2.6	50	43.7	2.34	51.0	42.8	18.7	2.9	
			60	51.2	2.37	58.6	51.5	21.6	2.8	
			70	59.3	2.39	66.7	60.1	24.8	2.7	
			80	67.7	2.41	75.3	68.7	28.1	2.6	
90	6	0.7	50	37.6	3.11	47.0	43.8	12.1	2.9	
			60	44.0	3.18	53.7	52.7	13.8	2.8	
			70	51.1	3.25	61.0	61.5	15.7	2.7	
			80							
	9	1.5	50	38.5	2.98	47.5	43.6	12.9	2.9	
			60	45.3	3.02	54.5	52.5	15.0	2.8	
			70	52.7	3.06	62.1	61.2	17.2	2.7	
			80							
	12	2.5	50	39.1	2.93	48.0	43.5	13.3	2.9	
			60	46.0	2.96	55.1	52.4	15.5	2.8	
			70	53.6	2.99	62.7	61.1	17.9	2.7	
			80							
110	6	0.7	50	33.0	3.88	44.5	44.5	8.5	2.9	
			60	39.1	3.96	51.0	53.5	9.9	2.8	
			70	45.5	4.06	57.8	62.4	11.2	2.7	
			80							
	9	1.4	50	33.9	3.74	45.1	44.4	9.1	2.9	
			60	40.2	3.79	51.6	53.3	10.6	2.8	
			70	46.9	3.85	58.6	62.2	12.2	2.7	
			80							
	12	2.3	50	34.3	3.68	45.4	44.3	9.3	2.9	
			60	40.7	3.72	51.9	53.2	10.9	2.8	
			70	47.6	3.76	59.0	62.1	12.6	2.7	
			80							
90										

- Notes::
- 1 Antifreeze required on Load side for this operation
 - 2 Interpolation is permissible. Not extrapolation
 - 3 XXXXXXXXXX = Operation not recommended

HW060 Heating Performance - PART LOAD

SOURCE			LOAD 6.5 GPM						
EWT	GPM	Pressure Drop (PSI)	EWT	Heating Capacity, MBH	Power, KW	Heat Absorb, MBH	Lvg Water Temp	COP	Pressure Drop (PSI)
30	6.5	1.0	60	33.9	1.90	28.1	70.4	5.2	0.9
			80	31.9	2.42	24.8	89.8	3.9	0.9
			100	29.1	3.09	20.3	109.0	2.8	0.8
			120	26.4	3.91	15.6	128.2	2.0	0.8
	9.8	2.1	60	36.4	1.93	30.5	71.2	5.5	0.9
			80	33.3	2.45	26.1	90.3	4.0	0.9
			100	30.3	3.12	21.3	109.4	2.9	0.8
			120	27.3	3.94	16.3	128.5	2.0	0.8
	13	3.5	60	37.4	1.97	31.4	71.5	5.6	0.9
			80	34.1	2.49	26.8	90.6	4.0	0.9
			100	30.9	3.16	21.8	109.6	2.9	0.8
			120	27.7	3.98	16.6	128.6	2.0	0.8
50	6.5	1.0	60	45.5	1.90	39.7	74.0	7.0	0.9
			80	41.8	2.44	34.5	92.9	5.0	0.9
			100	39.1	3.12	29.9	112.1	3.7	0.8
			120	36.4	3.97	24.8	131.3	2.7	0.8
	9.8	2.0	60	46.9	1.92	41.0	74.4	7.2	0.9
			80	44.0	2.46	36.6	93.6	5.2	0.9
			100	40.9	3.15	31.6	112.7	3.8	0.8
			120	37.8	3.99	26.2	131.8	2.8	0.8
	13	3.3	60	48.7	1.95	42.7	75.0	7.3	0.9
			80	45.3	2.50	37.8	94.0	5.3	0.9
			100	41.9	3.19	32.4	113.0	3.9	0.8
			120	38.6	4.02	26.8	132.0	2.8	0.8
70	6.5	0.9	60	55.3	1.82	49.8	77.0	8.9	0.9
			80	52.0	2.37	44.9	96.1	6.4	0.9
			100	49.0	3.06	39.9	115.2	4.7	0.8
			120	46.0	3.89	34.5	134.3	3.5	0.8
	9.8	1.9	60	58.9	1.81	53.3	78.1	9.5	0.9
			80	55.0	2.37	47.8	97.0	6.8	0.8
			100	51.4	3.07	42.3	116.0	4.9	0.8
			120	48.0	3.90	36.4	134.9	3.6	0.8
	13	3.1	60	59.8	1.84	54.1	78.4	9.6	0.9
			80	56.6	2.39	49.4	97.5	6.9	0.8
			100	52.8	3.09	43.5	116.4	5.0	0.8
			120						
90	6.5	0.9	60						
			80						
			100						
			120						
	9.8	1.8	60						
			80						
			100						
			120						
	13	2.9	60						
			80						
			100						
			120						

Notes::

- 1 Antifreeze required on Load side for this operation
- 2 Interpolation is permissible. Not extrapolation
- 3 XXXXXXXXXX = Operation not recommended

HW060 Heating Performance - PART LOAD cont.

SOURCE			LOAD 9.8 GPM							
EWT	GPM	Pressure Drop (PSI)	EWT	Heating Capacity, MBH	Power, KW	Heat Absorb, MBH	Lvg Water Temp	COP	Pressure Drop (PSI)	
30	6.5	1.0	60							
			80	32.3	2.36	25.3	86.7	4.0	1.8	
			100	29.5	3.03	20.8	106.1	2.9	1.6	
			120	26.6	3.86	15.9	125.5	2.0	1.6	
	9.8	2.1	60							
			80	33.8	2.38	26.8	87.0	4.2	1.8	
			100	30.7	3.05	21.9	106.3	3.0	1.6	
			120	27.5	3.88	16.7	125.7	2.1	1.6	
	13	3.5	60							
			80	34.7	2.42	27.5	87.1	4.2	1.8	
			100	31.3	3.09	22.4	106.5	3.0	1.6	
			120	28.0	3.92	17.0	125.8	2.1	1.6	
50	6.5	1.0	60	45.2	1.82	39.6	69.3	7.3	1.9	
			80	42.3	2.34	35.3	88.7	5.3	1.7	
			100	39.6	3.02	30.6	108.2	3.8	1.6	
			120	36.7	3.87	25.5	127.6	2.8	1.6	
	9.8	2.0	60	47.8	1.83	42.1	69.8	7.7	1.9	
			80	44.7	2.36	37.6	89.2	5.6	1.7	
			100	41.5	3.04	32.4	108.6	4.0	1.6	
			120	38.2	3.89	26.9	127.9	2.9	1.6	
	13	3.3	60	48.8	1.86	43.0	70.0	7.7	1.9	
			80	46.0	2.39	38.8	89.5	5.7	1.7	
			100	42.5	3.08	33.4	108.8	4.1	1.6	
			120	39.0	3.92	27.5	128.1	2.9	1.6	
70	6.5	0.9	60	56.2	1.70	51.0	71.5	9.7	1.9	
			80	52.8	2.24	46.0	90.9	6.9	1.7	
			100	49.7	2.93	41.0	110.3	5.0	1.6	
			120	46.5	3.76	35.4	129.7	3.6	1.6	
	9.8	1.9	60	59.2	1.69	53.9	72.1	10.3	1.9	
			80	55.9	2.23	49.2	91.5	7.4	1.7	
			100	52.2	2.92	43.5	110.8	5.2	1.6	
			120	48.6	3.76	37.5	130.1	3.8	1.6	
	13	3.1	60	60.1	1.72	54.8	72.3	10.3	1.9	
			80	57.7	2.24	50.9	91.9	7.6	1.7	
			100	53.7	2.94	44.9	111.1	5.4	1.6	
			120	49.7	3.78	38.5	130.3	3.9	1.6	
90	6.5	0.9	60							
			80							
			100							
			120							
	9.8	1.8	60							
			80							
			100							
			120							
	13	2.9	60							
			80							
			100							
			120							

Notes::

- 1 Antifreeze required on Load side for this operation
- 2 Interpolation is permissible. Not extrapolation
- 3 XXXXXXXXXX = Operation not recommended

HW060 Heating Performance - PART LOAD cont.

SOURCE			LOAD 13 GPM						
EWT	GPM	Pressure Drop (PSI)	EWT	Heating Capacity, MBH	Power, KW	Heat Absorb, MBH	Lvg Water Temp	COP	Pressure Drop (PSI)
30	6.5	1.0	60						
			80	32.6	2.35	25.7	85.0	4.1	2.9
			100	29.7	3.02	21.1	104.6	2.9	2.8
			120	26.8	3.85	16.1	124.2	2.0	2.6
	9.8	2.1	60						
			80	34.2	2.37	27.1	85.3	4.2	2.9
			100	31.0	3.04	22.2	104.8	3.0	2.8
			120	27.7	3.88	16.9	124.3	2.1	2.6
	13	3.5	60						
			80	35.0	2.41	27.8	85.4	4.3	2.9
			100	31.6	3.07	22.7	104.9	3.0	2.8
			120	28.3	3.91	17.2	124.4	2.1	2.6
50	6.5	1.0	60						
			80	42.6	2.32	35.6	86.6	5.4	2.9
			100	39.9	2.99	31.0	106.2	3.9	2.8
			120	37.0	3.85	25.8	125.8	2.8	2.6
	9.8	2.0	60	48.0	1.81	42.4	67.4	7.8	3.1
			80	45.1	2.33	38.1	87.0	5.7	2.9
			100	41.8	3.01	32.9	106.5	4.1	2.8
			120	38.5	3.86	27.2	126.0	2.9	2.6
	13	3.3	60	48.7	1.84	43.0	67.5	7.8	3.1
			80	46.5	2.36	39.3	87.2	5.8	2.9
			100	42.9	3.04	33.8	106.7	4.1	2.8
			120	39.4	3.89	27.9	126.1	3.0	2.6
70	6.5	0.9	60	57.2	1.67	52.0	68.8	10.1	3.1
			80	53.2	2.20	46.6	88.2	7.1	2.9
			100	50.1	2.88	41.5	107.8	5.1	2.8
			120	46.9	3.70	36.0	127.3	3.7	2.6
	9.8	1.9	60	58.8	1.67	53.6	69.0	10.3	3.1
			80	56.5	2.18	49.8	88.7	7.6	2.9
			100	52.7	2.87	44.2	108.2	5.4	2.8
			120	49.1	3.70	38.1	127.6	3.9	2.6
	13	3.1	60	62.5	1.66	57.3	69.6	11.0	3.1
			80	58.4	2.19	51.7	89.0	7.8	2.9
			100	54.2	2.88	45.6	108.4	5.5	2.8
			120						
90	6.5	0.9	60						
			80						
			100						
			120						
	9.8	1.8	60						
			80						
			100						
			120						
	13	2.9	60						
			80						
			100						
			120						

Notes::

- 1 Antifreeze required on Load side for this operation
- 2 Interpolation is permissible. Not extrapolation
- 3 XXXXXXXXXX = Operation not recommended

HW060 Heating Performance - FULL LOAD

SOURCE			LOAD 6.5 GPM							
EWT	GPM	Pressure Drop (PSI)	EWT	Heating Capacity, MBH	Power, KW	Heat Absorb, MBH	Lvg Water Temp	COP	Pressure Drop (PSI)	
30	6.5	1.0	60	44.4	2.60	36.3	73.6	5.0	0.9	
			80	42.5	3.25	32.6	93.1	3.8	0.9	
			100	40.8	4.03	28.7	112.7	3.0	0.8	
			120	41.4	5.05	26.4	132.9	2.4	0.8	
	9.8	2.2	60	47.1	2.67	38.8	74.5	5.2	0.9	
			80	44.9	3.31	34.8	93.9	4.0	0.9	
			100	42.6	4.10	30.3	113.2	3.1	0.8	
			120	43.0	5.11	27.8	133.4	2.5	0.8	
	13	3.6	60	48.6	2.73	40.1	74.9	5.2	0.9	
			80	46.1	3.37	35.8	94.3	4.0	0.9	
			100	44.8	4.18	32.1	113.9	3.1	0.8	
			120	43.9	5.16	28.4	133.7	2.5	0.8	
50	6.5	1.0	60	56.1	2.77	47.4	77.3	5.9	0.9	
			80	53.8	3.44	43.2	96.6	4.6	0.9	
			100	52.5	4.26	39.5	116.3	3.6	0.8	
			120	51.7	5.28	35.8	136.1	2.9	0.8	
	9.8	2.0	60	60.1	2.84	51.2	78.5	6.2	0.9	
			80	57.3	3.49	46.5	97.7	4.8	0.8	
			100	56.9	4.35	43.6	117.7	3.8	0.8	
			120	52.9	5.30	36.8	136.5	2.9	0.8	
	13	3.3	60	62.3	2.89	53.2	79.2	6.3	0.9	
			80	59.4	3.55	48.4	98.4	4.9	0.8	
			100	56.2	4.37	42.8	117.4	3.8	0.8	
			120	54.9	5.40	38.5	137.1	3.0	0.8	
70	6.5	0.9	60	69.3	2.93	60.1	81.3	6.9	0.9	
			80	67.0	3.59	55.9	100.7	5.5	0.8	
			100	66.8	4.48	53.0	120.7	4.4	0.8	
			120	64.2	5.53	47.3	140.0	3.4	0.8	
	9.8	1.9	60	75.2	3.03	65.7	83.2	7.3	0.9	
			80	71.4	3.67	60.0	102.1	5.7	0.8	
			100	70.7	4.55	56.7	122.0	4.6	0.8	
			120	66.7	5.59	49.5	140.8	3.5	0.8	
	13	3.1	60	78.1	3.10	68.4	84.1	7.4	0.9	
			80	73.9	3.74	62.3	102.9	5.8	0.8	
			100	73.7	4.63	59.5	122.9	4.7	0.8	
			120	66.7	5.60	49.5	140.8	3.5	0.8	
90	6.5	0.9	60	90.7	3.22	80.5	87.9	8.3	0.9	
			80							
			100							
			120							
	9.8	1.8	60							
			80							
			100							
			120							
	13	3.3	60							
			80							
			100							
			120							

Notes::

- 1 Antifreeze required on Load side for this operation
- 2 Interpolation is permissible. Not extrapolation
- 3 XXXXXXXXXX = Operation not recommended

HW060 Heating Performance - FULL LOAD cont.

SOURCE			LOAD 9.8 GPM							
EWT	GPM	Pressure Drop (PSI)	EWT	Heating Capacity, MBH	Power, KW	Heat Absorb, MBH	Lvg Water Temp	COP	Pressure Drop (PSI)	
30	6.5	1.0	60	45.0	2.50	37.3	69.2	5.3	1.9	
			80	42.9	3.14	33.3	88.8	4.0	1.7	
			100	40.8	3.91	29.0	108.4	3.1	1.6	
			120	41.5	4.93	26.8	128.6	2.5	1.6	
	9.8	2.2	60	47.7	2.55	39.7	69.8	5.5	1.9	
			80	45.1	3.19	35.3	89.3	4.1	1.7	
			100	44.0	3.99	32.0	109.1	3.2	1.6	
			120	43.2	4.98	28.3	129.0	2.5	1.6	
	13	3.6	60	49.3	2.61	41.1	70.1	5.5	1.9	
			80	46.4	3.25	36.4	89.6	4.2	1.7	
			100	45.3	4.05	33.0	109.4	3.3	1.6	
			120	44.1	5.02	29.0	129.2	2.6	1.6	
50	6.5	1.0	60	56.8	2.63	48.5	71.6	6.3	1.9	
			80	54.3	3.28	44.2	91.2	4.9	1.7	
			100	54.0	4.11	41.5	111.2	3.9	1.6	
			120	52.1	5.10	36.6	130.8	3.0	1.6	
	9.8	2.0	60	61.0	2.68	52.6	72.5	6.7	1.9	
			80	58.0	3.32	47.7	92.0	5.1	1.7	
			100	55.0	4.14	42.3	111.4	3.9	1.6	
			120	52.6	5.11	37.1	130.9	3.0	1.6	
	13	3.3	60	63.6	2.74	54.9	73.0	6.8	1.9	
			80	60.2	3.38	49.8	92.4	5.2	1.7	
			100	57.2	4.19	44.4	111.8	4.0	1.6	
			120	55.8	5.20	39.9	131.6	3.1	1.6	
70	6.5	0.9	60	70.5	2.76	61.8	74.5	7.5	1.9	
			80	67.7	3.39	57.1	93.9	5.9	1.7	
			100	67.2	4.23	54.2	113.9	4.7	1.6	
			120	64.7	5.28	48.4	133.4	3.6	1.6	
	9.8	1.9	60	76.4	2.84	67.4	75.7	7.9	1.9	
			80	69.1	3.42	58.5	94.2	5.9	1.7	
			100	69.6	4.26	56.4	114.4	4.8	1.6	
			120	68.5	5.34	52.1	134.2	3.8	1.6	
	13	3.1	60	79.8	2.90	70.6	76.4	8.1	1.8	
			80	75.6	3.51	64.6	95.6	6.3	1.7	
			100	71.5	4.31	58.1	114.8	4.9	1.6	
			120	70.5	5.40	53.9	134.6	3.8	1.6	
90	6.5	0.9	60	92.2	2.99	82.7	78.9	9.0	1.8	
			80	87.7	3.58	76.5	98.1	7.2	1.7	
			100							
			120							
	9.8	1.8	60	96.2	3.05	86.5	79.7	9.2	1.8	
			80							
			100							
			120							
	13	3.3	60							
			80							
			100							
			120							

Notes::

- 1 Antifreeze required on Load side for this operation
- 2 Interpolation is permissible. Not extrapolation
- 3 ██████████ = Operation not recommended

HW060 Heating Performance - FULL LOAD cont.

SOURCE			LOAD 13 GPM							
EWT	GPM	Pressure Drop (PSI)	EWT	Heating Capacity, MBH	Power, KW	Heat Absorb, MBH	Lvg Water Temp	COP	Pressure Drop (PSI)	
30	6.5	1.0	60							
			80	43.1	3.11	33.6	86.7	4.1	2.9	
			100	41.2	3.88	29.5	106.4	3.1	2.8	
			120	41.6	4.89	27.1	126.5	2.5	2.6	
	9.8	2.2	60	48.1	2.52	40.2	67.4	5.6	3.1	
			80	45.5	3.15	35.8	87.0	4.2	2.9	
			100	43.2	3.93	31.3	106.7	3.2	2.8	
			120	43.0	4.93	28.2	126.7	2.6	2.6	
	13	3.6	60	49.7	2.57	41.6	67.6	5.7	3.1	
			80	47.2	3.21	37.3	87.3	4.3	2.9	
			100	45.9	4.01	33.7	107.1	3.4	2.8	
			120	44.3	4.98	29.3	126.9	2.6	2.6	
50	6.5	1.0	60	57.3	2.59	49.1	68.8	6.5	3.1	
			80	54.8	3.23	44.8	88.5	5.0	2.9	
			100	51.0	4.02	38.8	107.9	3.7	2.8	
			120	52.5	5.04	37.3	128.2	3.1	2.6	
	9.8	2.0	60	61.6	2.63	53.3	69.5	6.9	3.1	
			80	58.6	3.26	48.5	89.1	5.3	2.9	
			100	55.7	4.07	43.2	108.6	4.0	2.8	
			120	55.2	5.09	39.7	128.6	3.2	2.6	
	13	3.3	60	64.3	2.69	55.7	69.9	7.0	3.1	
			80	60.8	3.31	50.5	89.4	5.4	2.9	
			100	57.6	4.11	44.9	108.9	4.1	2.8	
			120	56.7	5.14	41.1	128.8	3.2	2.6	
70	6.5	0.9	60	71.5	2.71	62.9	71.0	7.7	3.1	
			80	71.6	3.33	61.2	91.1	6.3	2.9	
			100	66.9	4.12	54.2	110.4	4.8	2.8	
			120	63.3	5.16	47.4	129.9	3.6	2.6	
	9.8	1.9	60	77.2	2.77	68.4	71.9	8.2	3.1	
			80	71.3	3.35	60.8	91.0	6.2	2.9	
			100	69.5	4.16	56.7	110.8	4.9	2.8	
			120	66.7	5.21	50.7	130.4	3.8	2.6	
	13	3.1	60	80.9	2.84	71.8	72.4	8.4	3.1	
			80	80.0	3.44	69.2	92.4	6.8	2.9	
			100	72.1	4.20	59.1	111.2	5.0	2.8	
			120	70.7	5.27	54.5	131.0	3.9	2.6	
90	6.5	0.9	60	89.6	2.87	80.5	73.8	9.2	3.1	
			80	89.4	3.47	78.5	93.8	7.5	2.9	
			100	81.0	4.22	67.9	112.6	5.6	2.7	
			120							
	9.8	1.8	60	97.6	2.97	88.1	75.0	9.6	3.1	
			80	87.5	3.47	76.7	93.5	7.4	2.9	
			100							
			120							
	13	3.3	60							
			80							
			100							
			120							

Notes::

- 1 Antifreeze required on Load side for this operation
- 2 Interpolation is permissible. Not extrapolation
- 3 XXXXXXXXXX = Operation not recommended

HW060 Cooling Performance - PART LOAD

SOURCE			LOAD 6.5 GPM						
EWT	GPM	Pressure Drop (PSI)	EWT	Cooling Capacity, MBH	Power, KW	Loop Rej/Add, MBH	Lvg Water Temp	EER	Pressure Drop (PSI)
50	6.5	0.9	50						
			60						
			70	51.1	1.40	55.5	54.3	36.5	0.9
			80	57.8	1.36	62.1	62.2	42.6	0.9
			90						
	9.8	1.9	50						
			60						
			70						
			80						
			90						
	13	3.2	50						
			60						
			70						
			80						
			90						
70	6.5	0.9	50	34.9	1.91	40.7	39.3	18.3	1.0
			60	40.6	1.91	46.4	47.6	21.2	1.0
			70	46.7	1.89	52.5	55.6	24.7	0.9
			80	53.3	1.86	58.9	63.6	28.7	0.9
			90						
	9.8	1.8	50	35.8	1.84	41.4	39.0	19.5	1.0
			60	41.7	1.82	47.3	47.2	22.9	1.0
			70	48.1	1.79	53.6	55.2	27.0	0.9
			80	54.9	1.73	60.2	63.1	31.7	0.9
			90						
	13	3.0	50	36.3	1.82	41.9	38.9	19.9	1.0
			60	42.3	1.80	47.8	47.0	23.5	1.0
			70	48.8	1.75	54.2	55.0	27.9	0.9
			80	55.8	1.69	61.0	62.8	33.0	0.9
			90						
90	6.5	0.8	50	31.4	2.62	39.2	40.4	12.0	1.0
			60	37.1	2.63	44.9	48.6	14.1	1.0
			70	43.2	2.62	51.0	56.7	16.5	0.9
			80	49.6	2.59	57.4	64.7	19.1	0.9
			90						
	9.8	1.7	50	32.3	2.53	39.8	40.1	12.8	1.0
			60	38.1	2.52	45.7	48.3	15.1	1.0
			70	44.5	2.49	52.0	56.3	17.9	0.9
			80	51.2	2.44	58.6	64.2	21.0	0.9
			90						
	13	2.8	50	32.7	2.50	40.2	40.0	13.1	1.0
			60	38.6	2.49	46.1	48.2	15.5	1.0
			70	45.1	2.44	52.5	56.1	18.5	0.9
			80	52.1	2.38	59.3	64.0	21.9	0.9
			90						
110	6.5	0.8	50	27.0	3.34	36.8	41.7	8.1	1.0
			60	31.8	3.35	41.7	50.2	9.5	1.0
			70	38.1	3.35	48.0	58.3	11.4	0.9
			80	43.1	3.33	53.1	66.7	12.9	0.9
			90						
	9.8	1.6	50	27.3	3.24	36.8	41.7	8.4	1.0
			60	32.9	3.24	42.4	49.9	10.1	1.0
			70	38.5	3.21	48.1	58.2	12.0	0.9
			80	45.0	3.17	54.4	66.1	14.2	0.9
			90						
	13	2.7	50	27.6	3.22	37.1	41.6	8.6	1.0
			60	33.4	3.20	42.9	49.8	10.4	1.0
			70	39.2	3.16	48.7	57.9	12.4	0.9
			80	45.6	3.11	54.9	66.0	14.6	0.9
			90						

- Notes::
 1 Antifreeze required on Load side for this operation
 2 Interpolation is permissible. Not extrapolation
 3 [Redacted] = Operation not recommended

HW060 Cooling Performance - PART LOAD cont.

SOURCE			LOAD 9.8 GPM						
EWT	GPM	Pressure Drop (PSI)	EWT	Cooling Capacity, MBH	Power, KW	Loop Rej/Add, MBH	Lvg Water Temp	EER	Pressure Drop (PSI)
50	6.5	0.9	50						
			60						
			70	54.9	1.39	59.3	58.7	39.4	1.9
			80	62.3	1.35	66.5	67.2	46.2	1.8
			90						
	9.8	1.9	50						
			60						
			70						
			80						
			90						
	13	3.2	50						
			60						
			70						
			80						
			90						
70	6.5	0.9	50	37.1	1.93	43.0	42.4	19.2	2.0
			60	43.2	1.93	49.1	51.2	22.4	1.9
			70	50.1	1.89	55.9	59.7	26.5	1.9
			80						
			90						
	9.8	1.8	50	38.1	1.85	43.8	42.2	20.6	2.0
			60	44.5	1.83	50.2	50.9	24.3	1.9
			70	51.7	1.77	57.1	59.4	29.2	1.9
			80						
			90						
	13	3.0	50	38.7	1.83	44.3	42.1	21.1	2.0
			60	45.2	1.80	50.8	50.7	25.1	1.9
			70	52.5	1.74	57.9	59.2	30.3	1.9
			80						
			90						
90	6.5	0.8	50	33.4	2.64	41.2	43.2	12.6	2.0
			60	39.4	2.66	47.4	51.9	14.9	1.9
			70	46.2	2.63	54.1	60.5	17.6	1.9
			80						
			90						
	9.8	1.7	50	34.4	2.54	42.0	43.0	13.5	2.0
			60	40.7	2.54	48.3	51.7	16.0	1.9
			70	47.8	2.48	55.3	60.2	19.3	1.9
			80						
			90						
	13	2.8	50	34.9	2.51	42.4	42.9	13.9	2.0
			60	41.4	2.49	48.9	51.5	16.6	1.9
			70	48.6	2.43	55.9	60.0	20.0	1.9
			80						
			90						
110	6.5	0.8	50	28.0	3.37	37.8	44.3	8.3	2.0
			60	33.7	3.37	43.7	53.1	10.0	1.9
			70	40.1	3.36	50.1	61.8	12.0	1.9
			80						
			90						
	9.8	1.6	50	29.0	3.27	38.6	44.1	8.9	2.0
			60	34.9	3.24	44.5	52.9	10.7	1.9
			70	41.2	3.21	50.8	61.6	12.8	1.9
			80						
			90						
	13	2.7	50	29.2	3.23	38.8	44.0	9.0	2.0
			60	35.3	3.21	44.8	52.8	11.0	1.9
			70	41.9	3.16	51.4	61.4	13.3	1.9
			80						
			90						

Notes::

- 1 Antifreeze required on Load side for this operation
- 2 Interpolation is permissible. Not extrapolation
- 3 [Redacted] = Operation not recommended

HW060 Cooling Performance - PART LOAD cont.

SOURCE			LOAD 13 GPM						
EWT	GPM	Pressure Drop (PSI)	EWT	Cooling Capacity, MBH	Power, KW	Loop Rej/Add, MBH	Lvg Water Temp	EER	Pressure Drop (PSI)
50	6.5	0.9	50						
			60						
			70						
			80						
			90						
	9.8	1.9	50						
			60						
			70						
			80						
			90						
	13	3.2	50						
			60						
70									
80									
90									
70	6.5	0.9	50	38.2	1.97	44.2	44.2	19.4	3.3
			60	44.8	1.96	50.7	53.1	22.9	3.2
			70	51.9	1.92	57.8	62.0	27.1	3.1
			80						
			90						
	9.8	1.8	50	39.4	1.88	45.2	44.0	20.9	3.3
			60	46.2	1.85	51.9	52.9	25.0	3.2
			70	53.7	1.79	59.2	61.7	30.0	3.1
			80						
			90						
	13	3.0	50	40.0	1.86	45.7	43.9	21.5	3.3
			60	47.0	1.82	52.6	52.8	25.8	3.2
70			54.6	1.75	60.0	61.6	31.3	3.1	
80									
90									
90	6.5	0.8	50	34.3	2.68	42.3	44.7	12.8	3.3
			60	40.7	2.68	48.8	53.7	15.2	3.2
			70	47.8	2.65	55.8	62.6	18.0	3.1
			80						
			90						
	9.8	1.7	50	35.4	2.58	43.1	44.6	13.7	3.3
			60	42.1	2.56	49.9	53.5	16.5	3.2
			70	49.5	2.50	57.1	62.4	19.8	3.1
			80						
			90						
	13	2.8	50	36.0	2.55	43.7	44.5	14.2	3.3
			60	42.9	2.51	50.5	53.4	17.1	3.2
70			50.4	2.44	57.9	62.2	20.7	3.1	
80									
90									
110	6.5	0.8	50	28.0	3.37	37.8	44.3	8.3	2.0
			60	33.7	3.37	43.7	53.1	10.0	1.9
			70	40.1	3.36	50.1	61.8	12.0	1.9
			80						
			90						
	9.8	1.6	50	29.0	3.27	38.6	44.1	8.9	2.0
			60	34.9	3.24	44.5	52.9	10.7	1.9
			70	41.2	3.21	50.8	61.6	12.8	1.9
			80						
			90						
	13	2.7	50	29.2	3.23	38.8	44.0	9.0	2.0
			60	35.3	3.21	44.8	52.8	11.0	1.9
70			41.9	3.16	51.4	61.4	13.3	1.9	
80									
90									

Notes::

- 1 Antifreeze required on Load side for this operation
- 2 Interpolation is permissible. Not extrapolation
- 3 XXXXXXXXXX = Operation not recommended

HW060 Cooling Performance - FULL LOAD

SOURCE			LOAD 6.5 GPM							
EWT	GPM	Pressure Drop (PSI)	EWT	Cooling Capacity, MBH	Power, KW	Loop Rej/Add, MBH	Lvg Water Temp	EER	Pressure Drop (PSI)	
50	6.5	0.9	50	49.4	2.34	56.8	34.9	21.1	1.0	
			60	56.7	2.42	64.4	42.6	23.4	1.0	
			70	64.5	2.51	72.5	50.2	25.7	0.9	
			80	72.7	2.62	81.0	57.6	27.8	0.9	
			90	81.2	2.73	89.8	65.0	29.7	0.9	
	9.8	1.9	50							
			60							
			70	66.2	2.36	73.7	49.7	28.0	0.9	
			80	74.7	2.45	82.6	57.0	30.5	0.9	
			90							
	13	3.2	50							
			60							
			70							
			80							
			90	84.8	2.48	92.9	63.8	34.2	0.9	
70	6.5	0.9	50	45.9	2.95	55.1	36.0	15.6	1.0	
			60	53.0	3.02	62.4	43.8	17.5	1.0	
			70	60.5	3.11	70.2	51.4	19.5	0.9	
			80	68.3	3.21	78.4	59.0	21.3	0.9	
			90	76.4	3.31	86.8	66.4	23.1	0.9	
	9.8	1.8	50	47.0	2.81	55.7	35.6	16.7	1.0	
			60	54.3	2.86	63.3	43.4	19.0	1.0	
			70	62.1	2.92	71.3	50.9	21.3	0.9	
			80	70.3	2.99	79.8	58.3	23.5	0.9	
			90	78.9	3.08	88.6	65.7	25.6	0.9	
	13	3.0	50	47.5	2.76	56.2	35.5	17.2	1.0	
			60	55.0	2.80	63.8	43.1	19.6	1.0	
			70	63.0	2.85	72.0	50.7	22.1	0.9	
			80	71.3	2.91	80.6	58.0	24.5	0.9	
			90	80.1	2.99	89.6	65.3	26.8	0.9	
90	6.5	0.8	50	41.9	3.70	53.2	37.2	11.3	1.0	
			60	48.5	3.77	60.2	45.1	12.9	1.0	
			70	55.6	3.86	67.6	52.9	14.4	0.9	
			80	63.0	3.96	75.3	60.6	15.9	0.9	
			90	70.6	4.07	83.3	68.2	17.4	0.9	
	9.8	1.7	50	42.8	3.54	53.7	36.9	12.1	1.0	
			60	49.8	3.58	60.9	44.7	13.9	1.0	
			70	57.2	3.64	68.5	52.4	15.7	0.9	
			80	64.9	3.71	76.5	60.0	17.5	0.9	
			90	73.0	3.78	84.8	67.5	19.3	0.9	
	13	2.8	50	43.3	3.48	54.0	36.8	12.4	1.0	
			60	50.4	3.51	61.3	44.6	14.3	1.0	
			70	57.9	3.55	69.0	52.2	16.3	0.9	
			80	65.9	3.61	77.2	59.7	18.3	0.9	
			90	74.2	3.67	85.7	67.1	20.2	0.9	
110	6.5	0.8	50	37.6	4.58	51.5	38.5	8.2	1.0	
			60	43.8	4.67	58.1	46.6	9.4	1.0	
			70	50.3	4.78	65.0	54.5	10.5	0.9	
			80	57.2	4.89	72.3	62.4	11.7	0.9	
			90							
	9.8	1.6	50	38.4	4.40	51.8	38.3	8.7	1.0	
			60	44.9	4.48	58.6	46.2	10.0	1.0	
			70	51.7	4.54	65.7	54.1	11.4	0.9	
			80	58.9	4.61	73.2	61.8	12.8	0.9	
			90	66.4	4.69	81.0	69.5	14.2	0.9	
	13	2.7	50	38.8	4.35	52.1	38.1	8.9	1.0	
			60	45.4	4.40	58.9	46.1	10.3	1.0	
			70	52.4	4.45	66.2	53.9	11.8	0.9	
			80	59.8	4.49	73.7	61.6	13.3	0.9	
			90	67.5	4.55	81.7	69.2	14.9	0.9	

Notes::

- 1 Antifreeze required on Load side for this operation
- 2 Interpolation is permissible. Not extrapolation
- 3 XXXXXXXXXX = Operation not recommended

HW060 Cooling Performance - FULL LOAD cont.

SOURCE			LOAD 9.8 GPM							
EWT	GPM	Pressure Drop (PSI)	EWT	Cooling Capacity, MBH	Power, KW	Loop Rej/Add, MBH	Lvg Water Temp	EER	Pressure Drop (PSI)	
50	6.5	0.9	50	53.4	2.41	61.1	39.1	22.2	2.0	
			60	61.6	2.50	69.6	47.4	24.7	1.9	
			70	70.3	2.61	78.6	55.6	27.0	1.9	
			80	79.5	2.73	88.2	63.7	29.2	1.8	
			90							
	9.8	1.9	50							
			60							
			70	72.4	2.44	80.3	55.2	29.7	1.9	
			80	82.1	2.55	90.2	63.1	32.2	1.8	
			90	92.1	2.66	100.7	71.0	34.6	1.8	
	13	3.2	50							
			60							
			70							
			80	83.4	2.49	91.4	62.9	33.6	1.8	
			90	93.8	2.60	102.1	70.7	36.1	1.8	
70	6.5	0.9	50	49.5	3.01	58.9	39.9	16.5	2.0	
			60	57.4	3.09	67.0	48.3	18.6	1.9	
			70	65.7	3.19	75.7	56.5	20.6	1.9	
			80	74.4	3.30	84.8	64.7	22.5	1.8	
			90							
	9.8	1.8	50	50.8	2.85	59.7	39.7	17.8	2.0	
			60	59.0	2.91	68.1	47.9	20.2	1.9	
			70	67.7	2.99	77.2	56.1	22.7	1.9	
			80	76.9	3.08	86.6	64.2	25.0	1.8	
			90							
	13	3.0	50	51.4	2.80	60.2	39.5	18.4	2.0	
			60	59.8	2.85	68.8	47.8	21.0	1.9	
			70	68.8	2.91	78.0	55.9	23.6	1.9	
			80	78.2	2.99	87.7	63.9	26.2	1.8	
			90							
90	6.5	0.8	50	44.9	3.75	56.4	40.8	12.0	2.0	
			60	52.3	3.84	64.2	49.3	13.6	1.9	
			70	60.1	3.94	72.3	57.7	15.3	1.9	
			80	68.3	4.05	80.9	66.0	16.8	1.8	
			90							
	9.8	1.7	50	46.1	3.58	57.1	40.6	12.9	2.0	
			60	53.8	3.63	65.1	49.0	14.8	1.9	
			70	62.0	3.70	73.5	57.3	16.8	1.9	
			80	70.6	3.78	82.4	65.5	18.7	1.8	
			90							
	13	2.8	50	46.7	3.52	57.5	40.5	13.3	2.0	
			60	54.6	3.55	65.6	48.8	15.4	1.9	
			70	63.0	3.60	74.3	57.1	17.5	1.9	
			80	71.9	3.67	83.4	65.2	19.6	1.8	
			90							
110	6.5	0.8	50	40.1	4.64	54.2	41.8	8.6	2.0	
			60	46.9	4.75	61.4	50.4	9.9	1.9	
			70	54.1	4.86	69.1	58.9	11.1	1.9	
			80	61.4	4.99	76.9	67.4	12.3	1.8	
			90							
	9.8	1.6	50	41.1	4.45	54.7	41.6	9.2	2.0	
			60	48.2	4.53	62.1	50.2	10.6	1.9	
			70	55.8	4.60	70.0	58.6	12.1	1.9	
			80	63.8	4.68	78.3	66.9	13.6	1.8	
			90							
	13	2.7	50	41.6	4.39	55.0	41.5	9.5	2.0	
			60	48.8	4.44	62.5	50.0	11.0	1.9	
			70	56.7	4.49	70.5	58.4	12.6	1.9	
			80	64.9	4.55	79.0	66.7	14.3	1.8	
			90							

Notes::

- 1 Antifreeze required on Load side for this operation
- 2 Interpolation is permissible. Not extrapolation
- 3 XXXXXXXXXX = Operation not recommended

HW060 Cooling Performance - FULL LOAD cont.

SOURCE			LOAD 13 GPM							
EWT	GPM	Pressure Drop (PSI)	EWT	Cooling Capacity, MBH	Power, KW	Loop Rej/Add, MBH	Lvg Water Temp	EER	Pressure Drop (PSI)	
50	6.5	0.9	50	55.7	2.47	63.6	41.5	22.6	3.3	
			60	64.4	2.57	72.6	50.1	25.1	3.2	
			70	73.7	2.68	82.2	58.7	27.5	3.1	
			80	83.4	2.81	92.4	67.1	29.7	3.0	
			90							
	9.8	1.9	50							
			60	66.3	2.42	74.1	49.8	27.5	3.2	
			70	76.1	2.52	84.2	58.3	30.3	3.1	
			80	86.4	2.63	94.8	66.7	32.9	3.0	
			90							
	13	3.2	50							
			60							
			70							
			80	87.9	2.57	96.2	66.4	34.3	3.0	
			90							
70	6.5	0.9	50	51.5	3.06	61.1	42.1	16.8	3.3	
			60	59.8	3.15	69.7	50.8	19.0	3.2	
			70	68.6	3.26	78.9	59.4	21.0	3.1	
			80	77.8	3.39	88.5	68.0	23.0	3.0	
			90							
	9.8	1.8	50	52.9	2.90	62.0	41.9	18.2	3.3	
			60	61.6	2.97	71.0	50.5	20.8	3.2	
			70	70.9	3.05	80.6	59.1	23.3	3.1	
			80	80.8	3.15	90.7	67.6	25.7	3.0	
			90							
	13	3.0	50	53.7	2.85	62.6	41.8	18.8	3.3	
			60	62.6	2.90	71.8	50.4	21.6	3.2	
			70	72.1	2.97	81.6	58.9	24.3	3.1	
			80	82.3	3.06	92.0	67.3	26.9	3.0	
			90							
90	6.5	0.8	50	46.6	3.80	58.3	42.9	12.3	3.3	
			60	54.4	3.90	66.4	51.7	14.0	3.2	
			70	62.6	4.01	75.0	60.4	15.6	3.1	
			80	71.2	4.13	84.0	69.0	17.2	3.0	
			90							
	9.8	1.7	50	47.9	3.63	59.1	42.7	13.2	3.3	
			60	56.0	3.68	67.5	51.4	15.2	3.2	
			70	64.7	3.76	76.5	60.0	17.2	3.1	
			80	73.9	3.84	85.9	68.6	19.2	3.0	
			90							
	13	2.8	50	48.5	3.56	59.6	42.6	13.6	3.3	
			60	56.9	3.60	68.1	51.3	15.8	3.2	
			70	65.9	3.66	77.3	59.9	18.0	3.1	
			80	75.3	3.72	87.0	68.4	20.2	3.0	
			90							
110	6.5	0.8	50	40.1	4.64	54.2	41.8	8.6	2.0	
			60	46.9	4.75	61.4	50.4	9.9	1.9	
			70	54.1	4.86	69.1	58.9	11.1	1.9	
			80							
			90							
	9.8	1.6	50	41.1	4.45	54.7	41.6	9.2	2.0	
			60	48.2	4.53	62.1	50.2	10.6	1.9	
			70	55.8	4.60	70.0	58.6	12.1	1.9	
			80							
			90							
	13	2.7	50	41.6	4.39	55.0	41.5	9.5	2.0	
			60	48.8	4.44	62.5	50.0	11.0	1.9	
			70	56.7	4.49	70.5	58.4	12.6	1.9	
			80	64.9	4.55	79.0	66.7	14.3	1.8	
			90							

Notes::

- 1 Antifreeze required on Load side for this operation
- 2 Interpolation is permissible. Not extrapolation
- 3 XXXXXXXXXX = Operation not recommended

Anti-freeze correction table

Antifreeze Type	Antifreeze % volume	Cooling EWT 90 °F			Heating EWT 30 °F		WPD Correction Factor EWT 30°F
		Total Cap.	Sens. Cap	Power	Htg. Cap	Power	
Water	0	1.000	1.000	1.000	1.000	1.000	1.000
	5	0.997	0.997	1.004	0.989	0.997	1.060
Propylene Glycol	10	0.994	0.994	1.006	0.986	0.995	1.125
	15	0.990	0.990	1.009	0.978	0.988	1.190
	25	0.983	0.983	1.016	0.960	0.979	1.300
Methanol	5	0.997	0.997	1.003	0.990	0.997	1.060
	10	0.996	0.996	1.005	0.979	0.993	1.100
	15	0.994	0.994	1.008	0.970	0.990	1.140
Ethanol	5	0.998	0.998	1.002	0.981	0.994	1.160
	10	0.996	0.996	1.004	0.960	0.988	1.230
	15	0.992	0.992	1.006	0.944	0.983	1.280
	25	0.986	0.986	1.009	0.917	0.974	1.400
Ethylene Glycol	5	0.997	0.997	1.003	0.993	0.998	1.060
	10	0.995	0.995	1.004	0.986	0.996	1.120
	15	0.992	0.992	1.005	0.980	0.993	1.190
	25	0.988	0.988	1.009	0.970	0.990	1.330
	30	0.985	0.985	1.012	0.965	0.987	1.400

Operating Limits for Heat and Cooling	
Cooling	Standard Unit
Minimum ambient air temperature	50
Maximum ambient air temperature	100
Minimum entering load fluid temperature °F	50
Typical entering load fluid temperature °F	55
Maximum entering load fluid temperature °F	90
Minimum entering source fluid temperature °F	50
Water loop typical entering source fluid range temperature °F	70-90
Maximum entering source fluid temperature °F	110
Heating	Standard Unit
Minimum ambient air temperature °F	50
Maximum ambient air temperature °F	100
Minimum entering load fluid temperature °F	60
Typical entering load fluid temperature °F	100-110
Maximum entering load fluid temperature °F	120
Minimum entering source fluid temperature °F	30*
Water loop typical entering source fluid range temperature °F	50-70
Maximum entering source fluid temperature °F	90

*Antifreeze required for fluid temperatures below 50 °F

*Maximum and minimum fluid conditions are at unit rated flow rate.

*Maximum and minimum operating limits may not be combined. If one value is at either maximum or minimum, the other value(s) must be within normal operating range.

