

**Up to 14.0 SEER, 11.5 EER, PACKAGE GAS / ELECTRIC UNIT**  
**208/230-1-60, Single Phase, 2-5 Nominal Tons (Sizes 24-60)**  
**208/230-3-60 & 460-3-60, Three Phase, 3-5 Nominal Tons (Sizes 36-60)**

**REFRIGERATION CIRCUIT**

- Environmentally balanced R-410A refrigerant
- Copper tube/aluminum fin condenser and evaporator coils
- Dehumidification mode (airflow reduction) on all models

**EASY TO INSTALL AND SERVICE**

- Installs easily on a rooftop or at ground level
- Easy three-panel accessibility for maintenance and installation
- Easily converts to down discharge applications
- Combination gas heating and electric cooling
- Low NOx units available

**BUILT TO LAST**

- Induced-draft combustion and venting
- Pre-painted steel cabinet
- Direct spark ignition
- High efficiency ECM indoor blower motor on all models
- Aluminized steel tubular heat exchanger and 2" spacing wire grilles on PGD4 models (00), Stainless Steel tubular heat exchanger and hail guard (3/8" spacing) wire grilles on PGS4 models
- Vertical condenser fan discharge
- Full perimeter steel base rails
- High pressure switch provides added reliability for the compressor
- Single phase models with factory installed tin-coated copper evaporator main tubes PGD4 (TP), PGS4 (GP), 3-phase models with standard evaporator tubes PGS4 (GS) (Models with factory installed options are identified with letters in the 11th and 12th positions in the model number)

**LIMITED WARRANTY\***

**1 Phase PGS4 "E" Models**

- 3 year No Hassle Replacement™ limited warranty
- 10 year parts limited warranty (including compressor and coils) with timely registration
- 5 year parts limited warranty and 20 year heat exchanger limited warranty if not registered within 90 days of original installation.

**1 Phase PGD4 "E" Models**

- 15 year heat exchanger limited warranty
- 10 year parts limited warranty (including compressor and coils) with timely registration
- 5 year parts limited warranty and 15 year heat exchanger limited warranty if not registered within 90 days of original installation.

**3 Phase PGS4, PGD4 "E" Models**

- 10 year heat exchanger limited warranty
- 5 year compressor limited warranty
- 1 year parts limited warranty

\* See warranty certificate for complete details and restrictions



PGD4 – Representative model only, some models may vary in appearance.



Use of the AHRI Certified TM Mark indicates a manufacturer's participation in the program. For verification of certification for individual products, go to [www.ahridirectory.org](http://www.ahridirectory.org).

UNIT PERFORMANCE DATA									
Aluminized Steel Heat Exchanger	Stainless Steel Heat Exchanger	COOLING			HEATING			Unit Dimensions Height x Width x Depth in (mm)	Operating Weight lbs (kg)
		Capacity BTU/h	SEER	EER	Input BTU/h	Efficiency AFUE %			
						1Ø	3Ø		
PGD424040K <sup>†</sup> A*E	PGS424040K <sup>†</sup> A*E	23,600	14.0	11.5	40,000	81.0	-	43 <sup>3</sup> / <sub>4</sub> x 48 <sup>3</sup> / <sub>16</sub> x 32 <sup>5</sup> / <sub>8</sub> (1111 x 1224 x 829)	304 (138)
PGD424060K <sup>†</sup> A*E	PGS424060K <sup>†</sup> A*E	23,600	14.0	11.5	60,000	81.0	-		304 (138)
PGD430040K <sup>†</sup> A*E	PGS430040K <sup>†</sup> A*E	28,600	14.0	11.5	40,000	81.0	-	45 <sup>3</sup> / <sub>4</sub> x 48 <sup>3</sup> / <sub>16</sub> x 32 <sup>5</sup> / <sub>8</sub> (1162 x 1224 x 829)	336 (152)
PGD430060K <sup>†</sup> A*E	PGS430060K <sup>†</sup> A*E	28,600	14.0	11.5	60,000	81.0	-		336 (152)
PGD436060 <sup>†</sup> A*E	PGS436060 <sup>†</sup> A*E	34,800	14.0	11.5	60,000	81.0	80.0	51 <sup>3</sup> / <sub>4</sub> x 48 <sup>3</sup> / <sub>16</sub> x 32 <sup>5</sup> / <sub>8</sub> (1315 x 1224 x 829)	349 (158)
PGD436090 <sup>†</sup> A*E	PGS436090 <sup>†</sup> A*E	34,800	14.0	11.5	90,000	81.0	79.3		349 (158)
PGD442060 <sup>†</sup> A*E	PGS442060 <sup>†</sup> A*E	40,000	14.0	11.5	60,000	81.0	78.5	44 <sup>3</sup> / <sub>4</sub> x 48 <sup>3</sup> / <sub>16</sub> x 44 <sup>1</sup> / <sub>8</sub> (1137 x 1224 x 1123)	413 (187)
PGD442090 <sup>†</sup> A*E	PGS442090 <sup>†</sup> A*E	40,000	14.0	11.5	90,000	81.0	80.4		413 (187)
PGD448090 <sup>†</sup> A*E	PGS448090 <sup>†</sup> A*E	48,000	14.0	11.5	90,000	81.0	80.4		438 (199)
PGD448115 <sup>†</sup> A*E	PGS448115 <sup>†</sup> A*E	48,000	14.0	11.5	115,000	81.0	80.3	52 <sup>3</sup> / <sub>4</sub> x 48 <sup>3</sup> / <sub>16</sub> x 44 <sup>1</sup> / <sub>8</sub> (1340 x 1224 x 1123)	438 (199)
PGD448130 <sup>†</sup> A*E	PGS448130 <sup>†</sup> A*E	48,000	14.0	11.5	127,000	81.0	-		438 (199)
PGD460090 <sup>†</sup> A*E	PGS460090 <sup>†</sup> A*E	56,000	14.0	11.5	90,000	81.0	80.4		455 (206)
PGD460115 <sup>†</sup> A*E	PGS460115 <sup>†</sup> A*E	56,000	14.0	11.5	115,000	81.0	80.3	54 <sup>3</sup> / <sub>4</sub> x 48 <sup>3</sup> / <sub>16</sub> x 44 <sup>1</sup> / <sub>8</sub> (1391 x 1224 x 1123)	455 (206)
PGD460130 <sup>†</sup> A*E	PGS460130 <sup>†</sup> A*E	56,000	14.0	11.5	127,000	81.0	-		455 (206)

† K = 208/230-1-60, H = 208/230-3-60, L = 460-3-60

\* 0 = Standard, 1 = Low NOx

^^ 00 = Standard (PGS single phase), TP (single phase), GP (3-phase) = Tin Plated Evaporator Main Tubes plus Stainless Steel Heat Exchanger (single phase), GS = Standard Copper Evap Main Tubes plus Stainless Heat Exchanger (3-phase)

# MODEL NUMBER NOMENCLATURE

MODEL NOMENCLATURE											
MODEL SERIES	1	2	3	4	5,6	7,8,9	10	11,12	13	14	15
	<b>P</b>	<b>G</b>	<b>D</b>	<b>4</b>	<b>36</b>	<b>090</b>	<b>K</b>	<b>00</b>	<b>0</b>	<b>E</b>	<b>1</b>
P = Package											
G = Gas/Electric											
D = Standard											
S = Mainline w/ SS HX											
3 = 13											
4 = 14											
5 = 15											
24 = 24,000 BTUH = 2 Tons											
30 = 30,000 BTUH = 2.5 Tons											
36 = 36,000 BTUH = 3 Tons											
42 = 42,000 BTUH = 3.5 Tons											
48 = 48,000 BTUH = 4 Tons											
60 = 60,000 BTUH = 5 Tons											
000 = no factory heat											
040 = 40,000 BTU/hr											
060 = 60,000 BTU/hr											
090 = 90,000 BTU/hr											
115 = 115,000 BTU/hr											
130 = 127,000 or 130,000 BTU/hr											
K = 208/230-1-60											
H = 208/230-3-60											
L = 460-3-60											
00 = No options											
TP = Tin Coated Copper Evap Main Tubes (single phase)											
GP = Tin Coated Copper Evap Main Tubes plus Stainless Steel Heat Exchanger (single phase)											
GS = Standard Copper Evap Main Tubes plus Stainless Steel Heat Exchanger (3-phase)											
0 = Standard											
1 = Low NOx											
Sales Model Digit											
Engineering Digit											

## AHRI\* CAPACITIES

### Cooling Capacities and Efficiencies

UNIT SIZE	NOMINAL TONS	STANDARD CFM	COOLING CAPACITY	EER	SEER
24	2	800	23000	11.5	14.0
30	2.5	1000	28600	11.5	14.0
36	3	1150	34800	11.5	14.0
42	3.5	1350	40000	11.5	14.0
48	4	1550	46000	11.5	14.0
60	5	1750	56000	11.5	14.0

#### LEGEND

**dB**—Sound Levels (decibels)

**db**—Dry Bulb

**SEER**—Seasonal Energy Efficiency Ratio

**wb**—Wet Bulb

**COP**—Coefficient of Performance

\* Air Conditioning, Heating & Refrigeration Institute.

\*\*At "A" conditions—80°F (26.7°C) indoor db/67°F (19.4°C) indoor wb & 95°F

(35°C) outdoor db.

† Rated in accordance with U.S. Government DOE Department of Energy) test procedures and/or AHRI Standards 210/240.

#### Notes:

1. Ratings are net values, reflecting the effects of circulating fan heat.

Ratings are based on:

**Cooling Standard:** 80°F (26.7°C) db, 67°F wb (19.4°C) indoor entering-air temperature and 95°F db (35°C) outdoor entering-air temperature.

2. Before purchasing this appliance, read important energy cost and efficiency information available from your retailer.

## Gas Heating Capacities and Efficiencies, Single Phase Models

UNIT SIZE	HEATING INPUT (Btuh)	OUTPUT CAPACITY (Btuh)	TEMPERATURE RISE RANGE °F (°C)	AFUE (%)
24040 30040	40,000	33,000	25-55 (14-31)	81.0
24060 30060 36060 42060	60,000	49,000	25-55 (14-31)	81.0
36090 42090 48090 60090	90,000	73,000 74,000 74,000 74,000	35-65 (19-36)	81.0
48115 60115	115,000	94,000	30-60 (17-33)	81.0
48130 60130	127,000	104,000	35-65 (19-36)	81.0

**LEGEND**

**AFUE**—Annual Fuel Utilization Efficiency

NOTE: Before purchasing this appliance, read important energy cost and efficiency information available from your retailer.

## Gas Heating Capacities and Efficiencies, Three Phase Models

UNIT SIZE	HEATING INPUT (Btuh)	OUTPUT CAPACITY (Btuh)	TEMPERATURE RISE RANGE °F (°C)	AFUE (%)
36060 42060	60,000	48,000 47,000	25-55 (14-31)	80.0 78.5
36090 42090 48090 60090	90,000	72,000 73,000 73,000 73,000	35-65 (19-36)	79.3 80.4 80.4 80.4
48115 60115	115,000	93,000	30-60 (17-33)	80.3
48130 60130	130,000	103,000	35-65 (19-36)	78.9

**LEGEND**

**AFUE**—Annual Fuel Utilization Efficiency

NOTE: Before purchasing this appliance, read important energy cost and efficiency information available from your retailer.

## A-Weighted Sound Power Level (dBA)

UNIT SIZE	SOUND RATING	TYPICAL OCTAVE BAND SPECTRUM (dBA without tone adjustment)						
		125	250	500	1000	2000	4000	8000
24	73	54.3	61.3	55.2	54.8	57.1	53.6	43.1
30	73	58.1	59.4	61.2	64.1	59.2	56.8	50.9
36	74	58.7	62.8	65.7	67.8	63.7	58.9	51.7
42	74	54.4	59.0	61.2	62.1	58.9	53.5	46.7
48	73	57.1	57.6	60.5	62.7	58.2	56.4	50.7
60	76	64.4	59.7	59.6	60.6	59.8	55.5	47.8

NOTE: Tested in accordance with AHRI Standard 270-1995 (not listed in AHRI).

# PHYSICAL DATA

UNIT SIZE	24040	24060	30040	30060	36060	36090	42060	42090
<b>NOMINAL CAPACITY (ton)</b>	2	2	2-1/2	2-1/2	3	3	3-1/2	3-1/2
<b>SHIPPING WEIGHT lb.</b>	329	329	361	361	390	390	455	455
<b>SHIPPING WEIGHT (kg)</b>	149	149	164	164	177	177	206	206
<b>COMPRESSOR / QUANTITY</b>	Rotary / 1		Recip / 1		Scroll / 1			
<b>REFRIGERANT (R-410A)</b>								
Quantity lb.	5.3	5.3	5.5	5.5	8.2	8.2	6.2	6.2
Quantity (kg)	2.4	2.4	2.5	2.5	3.7	3.7	2.8	2.8
<b>REFRIGERANT METERING DEVICE</b>	Orifice				TXV		Orifice	
<b>ORIFICE ID in. / mm</b>	.059 / 1.5	.059 / 1.5	.061 / 1.55	.061 / 1.55	N/A		.073 / 1.85	.073 / 1.85
<b>OUTDOOR COIL</b>								
Rows...Fins/in.	1...21	1...21	1...21	1...21	1...21	1...21	1...21	1...21
Face Area (sq ft)	11.9	11.9	13.6	13.6	18.8	18.8	13.6	13.6
<b>OUTDOOR FAN</b>								
Nominal CFM	2500	2500	2700	2700	3200	3200	3600	3600
Diameter in.	24	24	24	24	24	24	26	26
Diameter (mm)	609.6	609.6	609.6	609.6	609.6	609.6	660.4	660.4
Motor Hp (Rpm)	1/10 (810)	1/10 (810)	1/10 (810)	1/10 (810)	1/5 (810)	1/5 (810)	1/5 (810)	1/5 (810)
<b>INDOOR COIL</b>								
Rows...Fins/in.	3...17	3...17	3...17	3...17	3...17	3...17	3...17	3...17
Face Area (sq ft)	3.7	3.7	3.7	3.7	3.7	3.7	4.7	4.7
<b>INDOOR BLOWER</b>								
Nominal Cooling Airflow (Cfm)	800	800	1000	1000	1150	1150	1350	1350
Size in.	10x10	10x10	10x10	10x10	11x10	11x10	11x10	11x10
Size (mm.)	254x254	254x254	254x254	254x254	279.4x254	279.4x254	279.4x254	279.4x254
Motor HP (RPM)	1/2 (1050)	1/2 (1050)	1/2 (1050)	1/2 (1050)	3/4 (1000)	3/4 (1000)	1/2 (1050)	1/2 (1050)
<b>FURNACE SECTION*</b>								
Burner Orifice No. (Qty...Drill Size)								
1 Phase Natural Gas (Factory Installed)	2...44	3...44	2...44	3...44	3...44	3...38	3...44	3...38
1 Phase Propane Gas	2...55	3...55	2...55	3...55	3...55	3...53	3...55	3...53
3 Phase Natural Gas (Factory Installed)			2...44	2...38	2...38	3...38	2...38	3...38
3 Phase Propane Gas			2...55	2...53	2...53	3...53	2...53	3...53
<b>HIGH-PRESSURE SWITCH (psig) Cut-out Reset (Auto)</b>	650 +/- 15 420 +/- 25							
<b>LOSS-OF-CHARGE / LOW-PRESSURE SWITCH (Liquid Line) (psig) cut-out Reset (auto)</b>	20 +/- 5 45 +/- 10		N/A					
<b>RETURN-AIR FILTERS†‡</b>							1 each 24x14x1 610x356x25 24x15x1 610x406x25	
Throwaway Size in. (mm)	2 each 20x12x1 508x305x25							

\*Based on altitude of 0 to 2000 ft (0-610 m).

† Required filter sizes shown are based on the larger of the AHRI (Air Conditioning Heating and Refrigeration Institute) rated cooling airflow or the heating airflow velocity of 300 to 350 ft/minute for throwaway type. Air filter pressure drop for non-standard filters must not exceed 0.08 IN. W.C.

‡ If using accessory filter rack refer to the filter rack installation instructions for correct filter sizes and quantity.

# PHYSICAL DATA

UNIT SIZE	48090	48115	48130	60090	60115	60130
<b>NOMINAL CAPACITY (ton)</b>	4	4	4	5	5	5
<b>SHIPPING WEIGHT lb</b>	480	480	480	497	497	497
<b>SHIPPING WEIGHT kg</b>	218	218	218	225	225	225
<b>COMPRESSOR / QUANTITY</b>	Scroll / 1					
<b>REFRIGERANT (R-410A)</b>						
Quantity lb	9.2	9.2	9.2	9.8	9.8	9.8
Quantity (kg.)	4.2	4.2	4.2	4.4	4.4	4.4
<b>REFRIGERANT METERING DEVICE</b>	Orifice					
<b>ORIFICE ID in./mm</b>	.080 / 2.03			.084 / 2.14		
<b>OUTDOOR COIL</b>						
Rows...Fins/in.	1...21	1...21	1...21	1...21	1...21	1...21
Face Area (sq ft)	21.4	21.4	21.4	23.3	23.3	23.3
<b>OUTDOOR FAN</b>						
Nominal Cfm	3600	3600	3600	4200	4200	4200
Diameter in.	26	26	26	26	26	26
Diameter (mm)	660.4	660.4	660.4	660.4	660.4	660.4
Motor Hp (Rpm)	1/5 (810)	1/5 (810)	1/5 (810)	1/5 (810)	1/5 (810)	1/5 (810)
<b>INDOOR COIL</b>						
Rows...Fins/in.	3...17	3...17	3...17	3...17	3...17	3...17
Face Area (sq ft)	4.7	4.7	4.7	5.6	5.6	5.6
<b>INDOOR BLOWER</b>						
Nominal Cooling Airflow (Cfm)	1550	1550	1550	1750	1750	1750
Size in.	11x10	11x10	11x10	11x10	11x10	11x10
Size (mm)	279.4x254	279.4x254	279.4x254	279.4x254	279.4x254	279.4x254
Motor HP (RPM)	1.0 (1075)	1.0 (1075)	1.0 (1075)	1.0 (1040)	1.0 (1040)	1.0 (1040)
<b>FURNACE SECTION*</b>						
<b>Burner Orifice No. (Qty...Drill Size)</b>						
1 & 3 Phase Natural Gas (Factory Installed)	3...38	3...33	3...31	3...38	3...33	3...31
1 & 3 Phase Propane Gas	3...53	3...51	3...49	3...53	3...51	3...49
<b>HIGH-PRESSURE SWITCH (psig) Cut-out Reset (Auto)</b>	650 +/- 15 420 +/- 25					
<b>LOSS-OF CHARGE / LOW-PRESSURE SWITCH (Liquid Line) (psig) cut-out Reset (auto)</b>	N/A					
<b>RETURN-AIR FILTERS Throwaway†‡ in. mm</b>	1 each 24x14x1 610x356x25 24x15x1 610x406x25			1 each 24x16x1 610x406x25 24x18x1 610x457x25		

\*Based on altitude of 0 to 2000 ft (0-610 m).

† Required filter sizes shown are based on the larger of the AHRI (Air Conditioning Heating and Refrigeration Institute) rated cooling airflow or the heating airflow velocity of 300 to 350 ft/minute for throwaway type. Air filter pressure drop for non-standard filters must not exceed 0.08 IN. W.C.

‡ If using accessory filter rack refer to the filter rack installation instructions for correct filter sizes and quantity.

## OPTIONS AND ACCESSORIES

ITEM	DESCRIPTION	FACTORY INSTALLED OPTION	FIELD INSTALLED ACCESSORY
Compressor Start Kit	Compressor Start Kit assists compressor start-up by providing additional starting torque on single phase units only.		X
Corporate Thermostats	Thermostats provide control for the system heating and cooling functions.		X
Crankcase Heater	Crankcase Heater provides anti-floodback protection for low-load cooling applications.		X*
Economizer	Horizontal Economizer with solid state controls and barometric relief dampers includes filter racks and provide outdoor air during cooling and reduce compressor operation.		X
	Vertical Economizer with solid state controls and barometric relief dampers includes filter racks and provide outdoor air during cooling and reduce compressor operation.		X
Filter Rack	Filter Rack features easy installation, serviceability, and high-filtering performance for vertical applications. Includes 1-in. filter.		X
Flat Roof Curbs	Flat Roof Curbs in both 11-in (279 mm) and 14-in. (356 mm) sizes are available for roof mounted applications.		X
Flue Discharge Deflector	Directs flue gas exhaust 90 degrees upward from current discharge.		X
High Altitude Propane Conversion Kit	High Altitude Propane Conversion Kit is for use at 2001 to 6000 ft. (611–1829 m) above sea level. Kit consists of propane gas orifices that compensate for gas heat operation at high altitude.		X
Low Ambient Kit	Low Ambient Kit (Motormaster II Control) allows the use of mechanical cooling down to outdoor temperatures as low as 0°F (-18°C) when properly installed.		X
Manual Outside Air Damper	Manual Outside Air Damper includes hood and filter rack with adjustable damper blade for up to 25% outdoor air.		X
Natural to Propane Gas Conversion Kit	Natural to Propane Gas Conversion Kit allows for conversion from natural gas to propane gas (0–2000 ft) (0–610 m)		X
Propane to Natural Gas Conversion Kit	Propane to Natural Gas Conversion Kit allows for conversion from propane to natural gas for altitudes of 0–2000 ft (0–610 m)		X
Square-to-Round Duct Transition Kit	Square-to-Round Duct Transition Kit enable 24–48 size units to be fitted to 14 in. (356 mm) round ductwork.		X
Outdoor Coil Dense Metal Wire Grille	3/8" spacing Dense Metal Wire Grille provide hail and vandalism protection. Factory installed on PGS4, field installed on PGD4.	X	X
Low Pressure Switch Kit	This kit is designed for use when a low pressure control is desired.		X

\*Refer to Price Page for application detail.

# ECONOMIZER

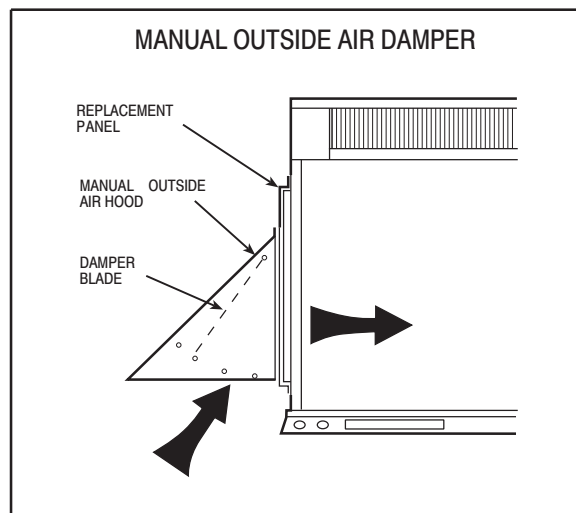
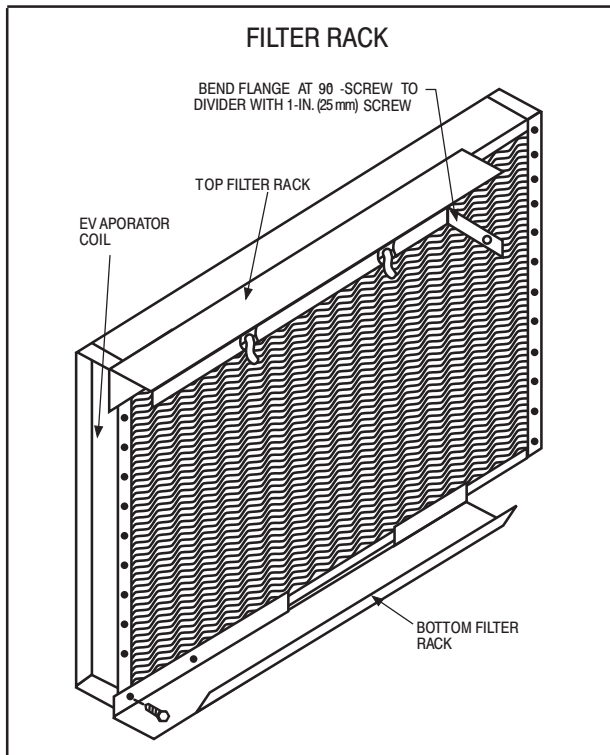
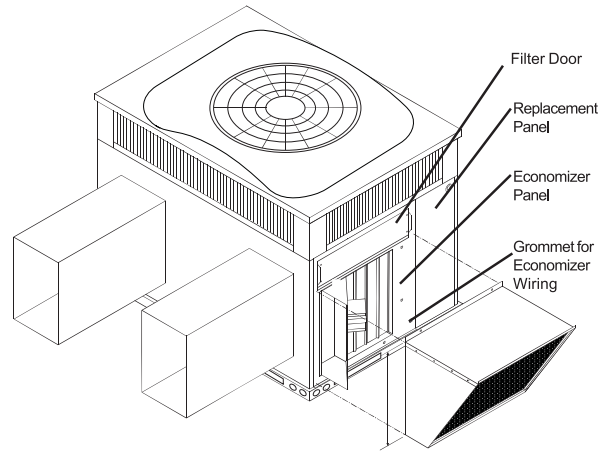
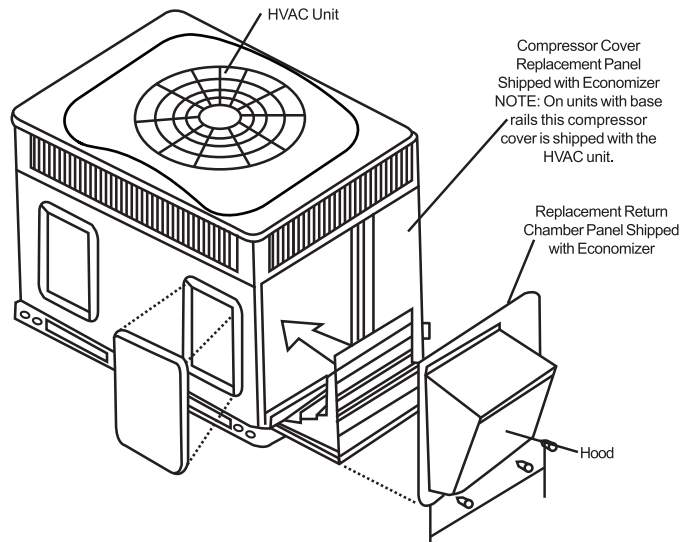
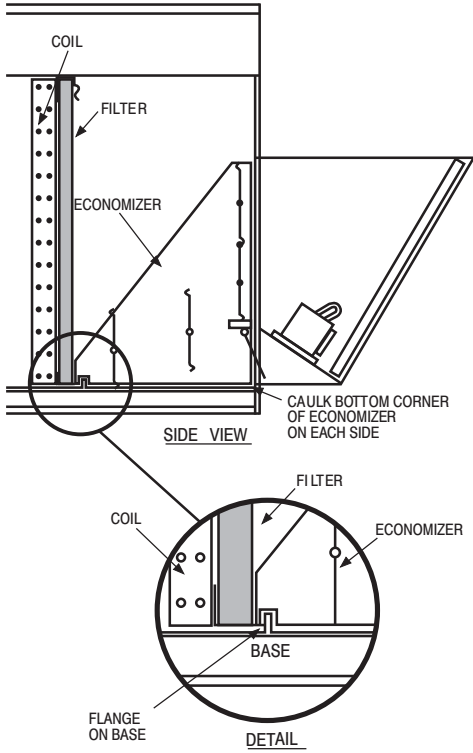

A09375

# UNIT DIMENSIONS - 24-36

UNIT	ELECTRICAL CHARACTERISTICS			UNIT WT. LB. / KG.	UNIT HEIGHT IN/MM	CENTER OF GRAVITY IN/MM				
	VOLTAGE	1" / 2" / 3"	4"			A"	X"	Y"	Z"	
PGD/S1424(040/060)K(00)GP/GS/TP1(07)1E1	24	208/230	45.6	20.7	60.8	27.6	91.2	41.4	106.4	148.3
PGD/S1430(040/060)K(00)GP/GS/TP1(07)1E1	30	208/230	50.4	22.9	67.2	30.5	100.8	45.7	117.6	153.3
PGD/S1436(060/090)K(H)H100(GP/GS/TP1(07)1E1)	36	208/230	52.4	23.7	69.8	31.7	104.7	47.5	122.2	155.4

UNIT	CORNER WEIGHT LB./KG.								
	1" / 2" / 3"	3"	4"						
24	208/230	45.6	20.7	60.8	27.6	91.2	41.4	106.4	148.3
30	208/230	50.4	22.9	67.2	30.5	100.8	45.7	117.6	153.3
36	208/230	52.4	23.7	69.8	31.7	104.7	47.5	122.2	155.4

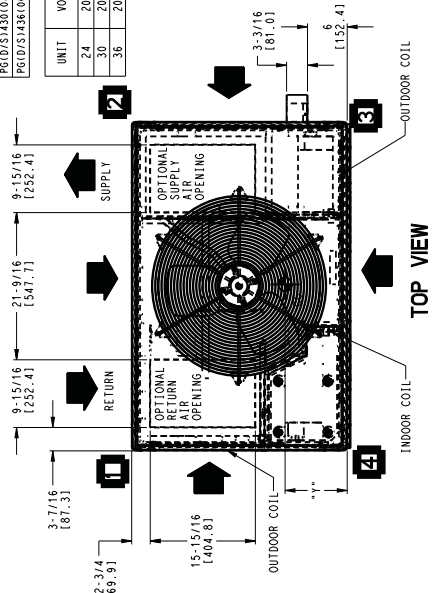

**TOP VIEW**

**REQUIRED CLEARANCES TO COMBUSTIBLE MATL.**

TOP OF UNIT..... 14 [355.6]  
 SIDE OF UNIT..... 14 [355.6]  
 SIDE OPPOSITE DUCTS..... 14 [355.6]  
 BOTTOM OF UNIT..... 1/2 [12.7]  
 FLUE PANEL..... 36 [914.4]

**NEC. REQUIRED CLEARANCES**

BETWEEN UNITS, POWER ENTRY SIDE..... 42 [1066.8]  
 UNIT AND UNGROUNDED SURFACES, POWER ENTRY SIDE..... 36 [914.0]  
 UNIT AND UNGROUNDED SURFACES, POWER ENTRY SIDE AND OTHER GROUNDED SURFACES, POWER ENTRY SIDE..... 42 [1066.8]

**REQUIRED CLEARANCE FOR OPERATION AND SERVICING**

EVAP. COIL ACCESS SIDE..... 36 [914.0]  
 POWER ENTRY SIDE..... 42 [1066.8]  
 (EXCEPT FOR NEC REQUIREMENTS)

UNIT TOP ACCESS PANELS..... 48 [1219.2]  
 UNIT TOP ACCESS PANELS AND OTHER DUCT PANEL..... 12 [304.8]

\*MINIMUM DISTANCES: IF UNIT IS PLACED LESS THAN 12 [304.8] FROM WALL SYSTEM, THEN SYSTEM PERFORMANCE MAY BE COMPROMISED.

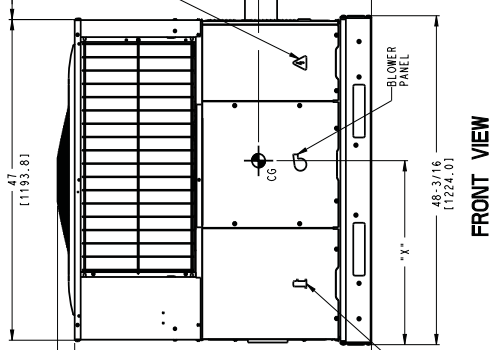

**FRONT VIEW**

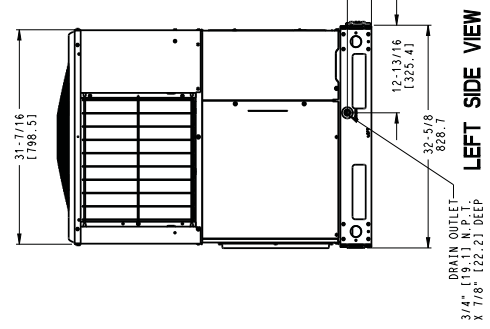

**LEFT SIDE VIEW**

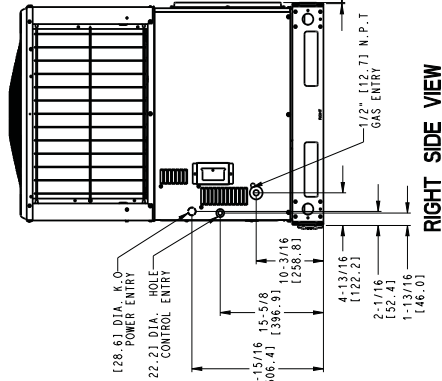

**RIGHT SIDE VIEW**

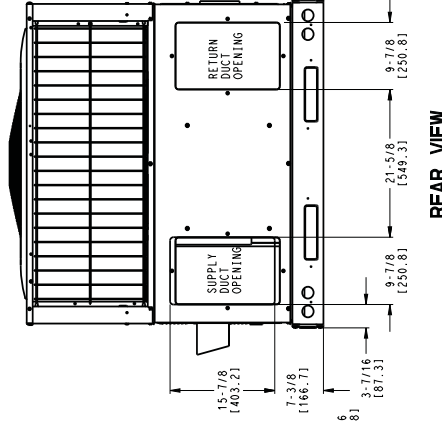

**REAR VIEW**

50CY502938



# ACCESSORY DIMENSIONS

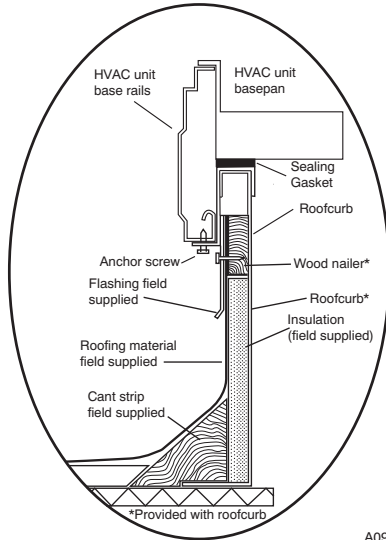

ROOF CURB DETAIL

A09090

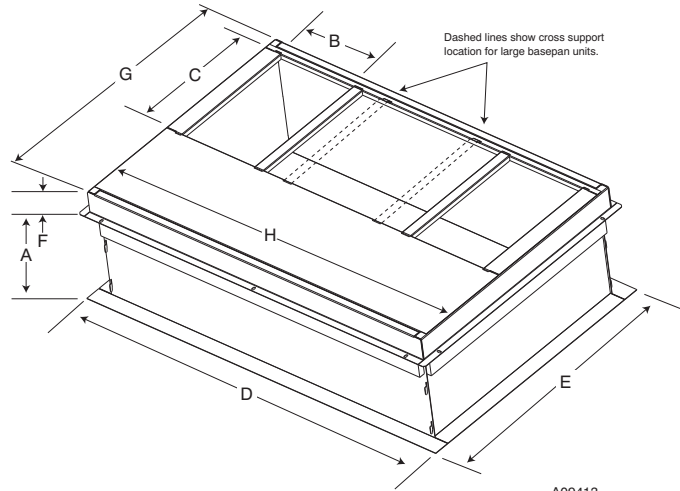

SMALL/COMMON CURB

A09413

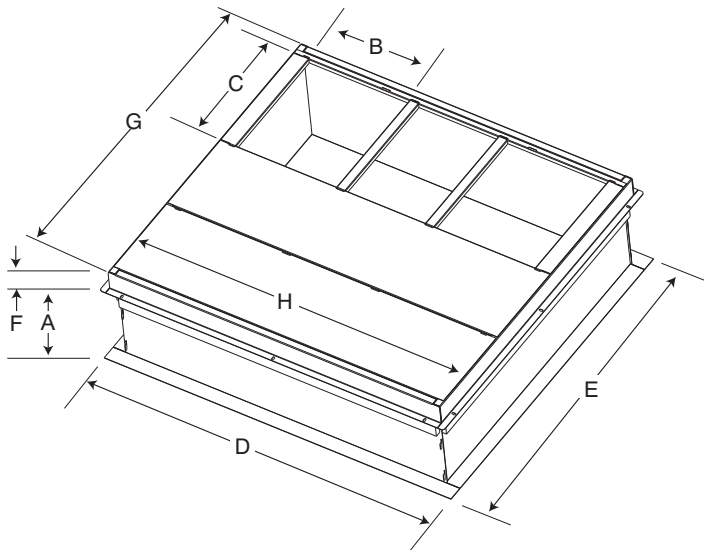

LARGE CURB

A09415

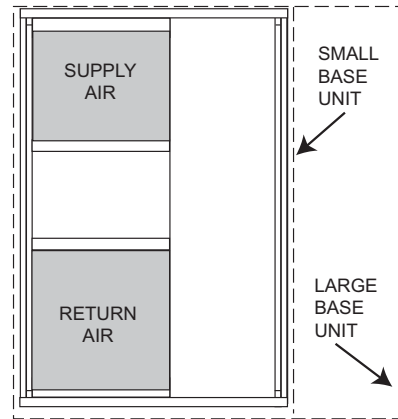

UNIT PLACEMENT ON COMMON CURB

A09094

SMALL OR LARGE BASE UNIT

A09414

UNIT SIZE	CATALOG NUMBER	A IN. (mm)	B (small / common base) IN. (mm)*	B (large base) IN. (mm)*	C IN. (mm)	D IN. (mm)	E IN. (mm)	F IN. (mm)	G IN. (mm)	H IN. (mm)
Small or Large	CPRFCURB011A00	14 (356)	10 (254)	14 (356)	16 (406)	47.8 (1214)	32.4 (822)	2.7 (69)	30.6 (778)	46.1 (1170)
				14 (356)			43.9 (1116)			
Large	CPRFCURB013A00	14 (356)	14 (356)							

\* Part Numbers CPRFCURB011A00 can be used on both small and large basepan units. The cross supports must be located based on whether the unit is a small basepan or a large basepan.

NOTES:

1. Roof curb must be set up for unit being installed.
2. Seal strip must be applied, as required, to unit being installed.
3. Roof curb is made of 16-gauge steel.
4. Attach ductwork to curb (flanges of duct rest on curb).
5. Insulated panels: 1-in. (25.4 mm) thick fiberglass 1 lb. density.

## SELECTION PROCEDURE (WITH EXAMPLE)

### 1. Determine cooling and heating requirements at design conditions:

Given:

Required Cooling Capacity (TC) . . . . . 34,000 Btuh  
Sensible Heat Capacity (SHC) . . . . . 25,000 Btuh  
Required Heating Capacity . . . . . 60,000 Btuh  
Condenser Entering Air Temperature . . 95°F (35°C)  
Indoor–Air Temperature 80°F (26°C)edb 67°F (19°C)ewb  
Evaporator Air Quantity . . . . . 1200 CFM  
External Static Pressure . . . . . 0.100 IN. W.C.  
Electrical Characteristics . . . . . 208–1–60

### 2. Select unit based on required cooling capacity.

Enter Net Cooling Capacities table at condenser entering temperature of 95°F (35°C). Unit 036 at 1200 cfm and 67°F (19°C) ewb (entering wet bulb) will provide a total capacity of 34,200 Btuh and a SHC of 27,400 Btuh. Calculate SHC correction, if required, using Note 4 under Cooling Capacities tables.

### 3. Select heating capacity of unit to provide design condition requirement.

In the Heating Capacities and Efficiencies table, note that the single phase unit 036090 will provide 73,000 Btuh with an input of 90,000 Btuh.

### 4. Determine fan speed and power requirements at design conditions.

Before entering the air delivery tables, calculate the total static pressure required. From the given example, the Wet Coil Pressure Drop Table, and the Filter Pressure Drop Table:

External Static Pressure	0.100 IN. W.C
Filter	0.07 IN. W.C
Wet Coil Pressure Drop	<u>0.180</u> IN. W.C
Total Static Pressure	0.287 IN. W.C

Enter the table for Dry Coil Air Delivery—Horizontal and Downflow Discharge. At .287 IN. W.C. ESP, the closest speed to 1200 CFM is Med–Low (pink wire), which delivers 1213 CFM at .3 in ESP.

### 5. Select unit that corresponds to power source available.

The Electrical Data Table shows that the unit is designed to operate at 208–1–60.

# PERFORMANCE DATA

## 24 SIZE

EVAPORATOR AIR		CONDENSER ENTERING AIR TEMPERATURES ° F (° C)																	
CFM	EWB F (° C)	75 (23.9)			85 (29.4)			95 (35)			105 (40.6)			115 (46.1)			125 (51.7)		
		Capacity MBtuh	Total Sys KW	Sens	Capacity MBtuh	Total Sys KW	Sens	Capacity MBtuh	Total Sys KW	Sens	Capacity MBtuh	Total Sys KW	Sens	Capacity MBtuh	Total Sys KW	Sens	Capacity MBtuh	Total Sys KW	Sens
700	57 (13.8)	23.62	1.55	23.62	21.90	21.90	20.07	20.07	19.55	17.88	17.88	15.87	15.87	14.01	14.01	2.64			
	62 (16.6)	24.47	1.56	22.45	20.24	20.32	19.02	19.02	1.96	17.92	17.92	15.90	15.90	14.03	14.03	2.64			
	63* (17.2)	24.99	1.56	22.88	16.39	20.71	15.32	15.32	1.96	18.05	14.06	15.56	12.87	13.28	11.77	2.61			
	67 (19.4)	27.02	1.55	24.79	17.09	22.51	16.03	16.03	1.98	19.92	14.86	17.28	13.67	14.91	12.59	2.67			
	72 (22.2)	29.59	1.55	27.20	13.77	24.84	12.86	12.86	1.99	22.48	11.95	19.68	10.89	17.14	9.92	2.77			
	57 (13.8)	24.74	1.57	22.92	22.92	21.02	21.02	1.99	18.78	18.78	16.65	16.65	14.70	14.70	2.69				
	62 (16.6)	25.14	1.57	23.07	21.80	21.05	21.05	1.99	18.81	18.81	16.68	16.68	14.72	14.72	2.69				
800	63* (17.2)	25.59	1.57	23.43	17.53	21.18	16.43	16.43	1.99	18.51	15.14	15.93	13.90	13.61	12.73	2.64			
	67 (19.4)	27.63	1.56	25.32	18.28	23.00	17.20	17.20	2.00	20.41	16.03	17.67	14.78	15.25	13.64	2.71			
	72 (22.2)	30.16	1.56	27.69	14.48	25.27	13.55	13.55	2.01	22.88	12.64	20.12	11.62	17.47	10.60	2.80			
	57 (13.8)	25.69	1.58	23.77	23.77	21.80	21.80	2.01	19.55	19.55	17.32	17.32	15.29	15.29	2.73				
900	62 (16.6)	25.74	1.58	23.81	23.81	21.84	21.84	2.01	19.58	19.58	17.35	17.35	15.31	15.31	2.73				
	63* (17.2)	26.07	1.58	23.84	18.62	21.55	17.49	17.49	2.01	18.84	16.17	16.24	14.87	13.92	13.92	2.67			
	67 (19.4)	28.08	1.58	25.72	19.42	23.37	18.31	18.31	2.02	20.82	17.17	17.98	15.84	15.54	14.63	2.74			
	72 (22.2)	30.58	1.58	28.07	15.15	25.58	14.21	14.21	2.02	23.17	13.29	20.45	12.30	17.73	11.25	2.83			

See Legend and Notes on Page 18.

# PERFORMANCE DATA

## 30 SIZE

EVAPORATOR AIR		CONDENSER ENTERING AIR TEMPERATURES ° F (° C)																	
		75 (23.9)			85 (29.4)			95 (35)			105 (40.6)			115 (46.1)			125 (51.7)		
		CFM	EWB F (° C)	Capacity MBtuh		Total Sys KW	Capacity MBtuh		Total Sys KW	Capacity MBtuh		Total Sys KW	Capacity MBtuh		Total Sys KW	Capacity MBtuh		Total Sys KW	
Total	Sens			Total	Sens		Total	Sens		Total	Sens		Total	Sens					
875	57 (13.8)	29.53	29.53	1.96	27.08	27.08	2.16	24.69	24.69	2.37	22.28	22.28	2.58	19.59	19.59	2.78	16.70	16.70	2.97
	62 (16.6)	30.79	26.57	1.97	27.80	24.83	2.18	24.94	23.09	2.38	22.32	22.32	2.58	19.63	19.63	2.78	16.73	16.73	2.98
	63* (17.2)	31.48	21.67	1.98	28.41	20.10	2.19	25.42	18.58	2.39	22.40	17.07	2.58	18.92	15.39	2.74	15.25	13.63	2.90
	67 (19.4)	34.28	22.60	1.99	31.11	21.08	2.22	27.95	19.57	2.45	24.83	18.09	2.67	21.50	16.55	2.87	17.54	14.78	3.02
	72 (22.2)	37.52	18.32	2.02	34.41	17.04	2.25	31.17	15.74	2.49	27.94	14.44	2.73	24.64	13.15	2.98	20.76	11.69	3.20
	57 (13.8)	31.03	31.03	2.01	28.44	28.44	2.22	25.91	25.91	2.44	23.40	23.40	2.66	20.68	20.68	2.87	17.58	17.58	3.06
1000	62 (16.6)	31.72	28.62	2.01	28.67	26.73	2.23	25.96	25.96	2.45	23.44	23.44	2.67	20.72	20.72	2.87	17.61	17.61	3.06
	63* (17.2)	32.32	23.12	2.01	29.14	21.51	2.23	26.02	19.93	2.44	22.95	18.37	2.64	19.44	16.64	2.80	15.73	15.73	2.96
	67 (19.4)	35.07	24.07	2.03	31.85	22.55	2.26	28.60	21.00	2.49	25.37	19.46	2.72	21.99	17.88	2.94	17.99	16.02	3.08
	72 (22.2)	38.18	19.12	2.05	35.03	17.87	2.29	31.75	16.57	2.53	28.42	15.25	2.78	25.07	13.95	3.02	21.25	12.54	3.27
1125	57 (13.8)	32.29	32.29	2.04	29.60	29.60	2.27	26.94	26.94	2.50	24.33	24.33	2.73	21.55	21.55	2.96	18.32	18.32	3.14
	62 (16.6)	32.53	30.43	2.05	29.65	29.65	2.27	26.98	26.98	2.50	24.37	24.37	2.73	21.59	21.59	2.96	18.35	18.35	3.14
	63* (17.2)	32.95	24.48	2.05	29.71	22.85	2.27	26.51	21.21	2.49	23.38	19.60	2.70	19.89	17.80	2.86	16.36	16.36	3.03
	67 (19.4)	35.66	25.45	2.06	32.37	23.93	2.29	29.08	22.34	2.53	25.80	20.77	2.76	22.40	19.14	2.99	18.47	18.31	3.15
	72 (22.2)	38.66	19.84	2.08	35.48	18.63	2.32	32.15	17.34	2.57	28.78	16.01	2.82	25.36	14.70	3.07	21.59	13.33	3.31

See Legend and Notes on Page 18.

# PERFORMANCE DATA (CONT)

## 36 SIZE

EVAPORATOR AIR		CONDENSER ENTERING AIR TEMPERATURES ° F (° C)																	
CFM	EWB F (° C)	75 (23.9)			85 (29.4)			95 (35)			105 (40.6)			115 (46.1)			125 (51.7)		
		Capacity MBtuh	Total Sys KW	Total Sys KW	Capacity MBtuh	Total Sys KW	Total Sys KW	Capacity MBtuh	Total Sys KW	Total Sys KW	Capacity MBtuh	Total Sys KW	Total Sys KW	Capacity MBtuh	Total Sys KW	Total Sys KW	Capacity MBtuh	Total Sys KW	Total Sys KW
1000	57 (13.8)	34.58	34.58	2.40	32.46	32.46	2.66	30.31	30.31	2.94	28.08	28.08	3.27	25.78	25.78	3.65	23.44	23.44	4.08
	62 (16.6)	36.10	31.44	2.41	33.65	29.92	2.67	31.16	28.38	2.95	28.62	26.75	3.27	26.05	25.03	3.65	23.48	23.48	4.08
	63* (17.2)	36.53	25.60	2.42	34.01	24.25	2.67	31.48	22.90	2.95	28.86	21.49	3.28	26.20	20.05	3.65	23.49	18.58	4.08
	67 (19.4)	39.44	26.70	2.43	36.74	25.34	2.69	34.00	23.95	2.97	31.20	22.53	3.30	28.34	21.07	3.67	25.45	19.58	4.09
	72 (22.2)	43.05	21.95	2.46	40.11	20.71	2.72	37.12	19.45	3.00	34.07	18.16	3.32	30.95	16.85	3.69	27.81	15.51	4.11
	57 (13.8)	36.19	36.19	2.46	33.98	33.98	2.71	31.67	31.67	3.00	29.30	29.30	3.32	26.84	26.84	3.70	24.34	24.34	4.12
1150	62 (16.6)	37.15	33.84	2.46	34.60	32.19	2.72	32.03	30.46	3.00	29.42	29.41	3.32	26.90	26.90	3.70	24.38	24.38	4.12
	63* (17.2)	37.52	27.28	2.47	34.89	25.86	2.72	32.23	24.43	3.01	29.50	22.95	3.33	26.72	21.43	3.70	23.92	19.88	4.12
	67 (19.4)	40.47	28.51	2.48	37.67	27.07	2.74	34.80	25.60	3.03	31.88	24.11	3.35	28.91	22.56	3.72	25.90	20.99	4.14
	72 (22.2)	44.12	23.06	2.51	41.04	21.76	2.77	37.93	20.44	3.06	34.77	19.10	3.38	31.54	17.73	3.74	28.28	16.32	4.16
	57 (13.8)	37.56	37.56	2.51	35.24	35.24	2.77	32.79	32.79	3.05	30.30	30.30	3.38	27.71	27.71	3.75	25.08	25.08	4.17
	62 (16.6)	38.06	35.99	2.51	35.47	34.14	2.77	32.84	32.84	3.05	30.34	30.34	3.38	27.75	27.75	3.75	25.12	25.12	4.17
1300	63* (17.2)	38.23	28.87	2.51	35.57	27.41	2.77	32.80	25.90	3.05	29.99	24.35	3.38	27.14	22.76	3.75	24.25	21.11	4.17
	67 (19.4)	41.26	30.24	2.53	38.33	28.73	2.79	35.38	27.20	3.08	32.36	25.62	3.40	29.31	24.01	3.76	26.22	22.34	4.18
	72 (22.2)	44.94	24.09	2.56	41.77	22.75	2.82	38.55	21.38	3.11	35.28	19.98	3.43	31.96	18.56	3.79	28.62	17.10	4.21

See Legend and Notes on Page 18.

# PERFORMANCE DATA

## 42 SIZE

EVAPORATOR AIR		CONDENSER ENTERING AIR TEMPERATURES ° F (° C)																	
		75 (23.9)			85 (29.4)			95 (35)			105 (40.6)			115 (46.1)			125 (51.7)		
		CFM	EWB F (° C)	Capacity MBtuh	Total Sys KW	Capacity MBtuh	Total Sys KW	Capacity MBtuh	Total Sys KW	Capacity MBtuh	Total Sys KW	Capacity MBtuh	Total Sys KW	Capacity MBtuh	Total Sys KW	Capacity MBtuh	Total Sys KW		
1175	57 (13.8)	38.66	38.66	2.51	36.66	36.66	2.87	34.60	34.60	3.30	32.45	32.45	3.80	30.07	30.07	4.39	27.19	27.19	5.02
	62 (16.6)	40.29	35.16	2.54	37.87	33.90	2.90	35.39	32.59	3.32	32.82	31.18	3.82	30.12	30.12	4.39	27.24	27.24	5.03
	63* (17.2)	41.08	28.70	2.54	38.62	27.55	2.92	36.06	26.34	3.34	33.40	25.10	3.84	30.40	30.40	4.40	26.65	22.06	4.98
	67 (19.4)	44.34	29.79	2.59	41.80	28.66	2.97	39.16	27.52	3.42	36.41	26.33	3.95	33.45	33.45	4.57	29.97	23.59	5.21
	72 (22.2)	48.52	24.17	2.66	45.92	23.18	3.05	43.20	22.16	3.52	40.37	21.10	4.06	37.44	20.00	4.70	34.27	18.84	5.44
	57 (13.8)	40.50	40.50	2.58	38.39	38.39	2.95	36.24	36.24	3.40	34.01	34.01	3.92	31.54	31.54	4.51	28.67	28.67	5.17
	62 (16.6)	41.38	37.85	2.59	38.93	36.52	2.96	36.44	36.11	3.41	34.06	34.06	3.92	31.59	31.59	4.52	28.72	28.72	5.17
1350	63* (17.2)	42.06	30.61	2.60	39.52	29.42	2.97	36.90	28.24	3.41	34.16	26.96	3.92	31.10	25.56	4.49	27.35	23.86	5.08
	67 (19.4)	45.33	31.78	2.64	42.72	30.67	3.03	40.00	29.50	3.48	37.18	28.29	4.01	34.18	27.02	4.64	30.76	25.56	5.32
	72 (22.2)	49.45	25.33	2.72	46.79	24.36	3.12	44.00	23.33	3.58	41.11	22.27	4.13	38.09	21.17	4.78	34.91	20.01	5.52
	57 (13.8)	41.99	41.99	2.63	39.82	39.82	3.02	37.59	37.59	3.47	35.28	35.28	4.01	32.78	32.78	4.63	29.92	29.92	5.31
1525	62 (16.6)	42.32	40.26	2.64	39.90	39.90	3.02	37.64	37.64	3.47	35.33	35.33	4.01	32.82	32.82	4.64	29.97	29.97	5.31
	63* (17.2)	42.81	32.42	2.65	40.22	31.23	3.02	37.53	30.01	3.47	34.76	28.74	3.99	31.66	27.29	4.56	27.97	25.57	5.17
	67 (19.4)	46.08	33.66	2.70	43.40	32.57	3.08	40.64	31.35	3.54	37.75	30.14	4.07	34.73	28.86	4.70	31.38	27.42	5.42
	72 (22.2)	50.14	26.41	2.78	47.44	25.44	3.18	44.60	24.44	3.64	41.64	23.37	4.20	38.57	22.27	4.85	35.35	21.11	5.59

See Legend and Notes on Page 18.

# PERFORMANCE DATA (CONT)

## 48 SIZE

EVAPORATOR AIR		CONDENSER ENTERING AIR TEMPERATURES ° F (° C)																			
		75 (23.9)			85 (29.4)			95 (35)			105 (40.6)			115 (46.1)			125 (51.7)				
		CFM	EWB F (° C)	Capacity MBtuh		Total Sys KW	Capacity MBtuh		Total Sys KW	Capacity MBtuh		Total Sys KW	Capacity MBtuh		Total Sys KW	Capacity MBtuh		Total Sys KW			
Total	Sens			Total	Sens		Total	Sens		Total	Sens		Total	Sens		Total	Sens				
1400	57 (13.8)	45.45	45.45	3.10	42.83	42.83	3.46	40.16	40.16	3.89	37.26	37.26	4.36	33.52	33.52	29.80	29.80	4.82	29.80	29.80	5.37
	62 (16.6)	47.27	42.17	3.13	44.15	40.29	3.49	41.03	38.39	3.91	37.61	36.29	4.36	33.57	33.57	29.84	29.84	4.83	29.84	29.84	5.37
	63* (17.2)	48.20	34.32	3.13	45.02	32.66	3.50	41.76	30.98	3.92	38.24	29.20	4.38	33.54	26.93	28.81	24.65	4.82	28.81	24.65	5.33
	67 (19.4)	52.06	35.63	3.15	48.74	34.02	3.52	45.33	32.35	3.95	41.77	30.64	4.44	37.35	28.63	32.39	26.38	4.96	32.39	26.38	5.46
	72 (22.2)	56.98	28.79	3.18	53.50	27.36	3.56	49.89	25.89	3.99	46.16	24.36	4.48	42.23	22.80	37.37	21.00	5.04	37.37	21.00	5.64
	57 (13.8)	47.02	47.02	3.17	44.27	44.27	3.54	41.50	41.50	3.96	38.53	38.53	4.44	34.79	34.79	30.91	30.91	4.92	30.91	30.91	5.46
1550	62 (16.6)	48.16	44.46	3.17	45.01	42.51	3.55	41.85	40.45	3.97	38.60	38.60	4.44	34.83	34.83	30.95	30.95	4.92	30.95	30.95	5.46
	63* (17.2)	49.02	35.96	3.18	45.75	34.27	3.55	42.41	32.55	3.98	38.87	30.75	4.45	34.15	28.45	29.32	26.09	4.89	29.32	26.09	5.40
	67 (19.4)	52.88	37.35	3.20	49.49	35.71	3.57	46.00	34.00	4.00	42.38	32.25	4.49	38.03	30.31	32.93	27.95	5.04	32.93	27.95	5.53
	72 (22.2)	57.73	29.76	3.23	54.20	28.31	3.61	50.51	26.84	4.04	46.68	25.28	4.53	42.70	23.71	37.92	21.96	5.09	37.92	21.96	5.70
	57 (13.8)	49.14	49.14	3.25	46.25	46.25	3.63	43.34	43.34	4.06	40.29	40.29	4.55	36.55	36.55	32.46	32.46	5.07	32.46	32.46	5.60
	62 (16.6)	49.49	47.88	3.25	46.34	46.34	3.63	43.39	43.39	4.06	40.34	40.34	4.55	36.60	36.60	32.49	32.49	5.07	32.49	32.49	5.61
1800	63* (17.2)	50.04	38.56	3.25	46.70	36.84	3.63	43.27	35.06	4.06	39.66	33.20	4.54	34.96	30.85	30.05	28.30	5.00	30.05	28.30	5.51
	67 (19.4)	53.94	40.13	3.28	50.43	38.42	3.65	46.85	36.63	4.08	43.16	34.80	4.57	38.95	32.92	33.66	30.41	5.12	33.66	30.41	5.65
	72 (22.2)	58.67	31.28	3.31	55.06	29.83	3.69	51.26	28.32	4.12	47.34	26.73	4.62	43.27	25.12	38.61	23.50	5.18	38.61	23.50	5.78

See Legend and Notes on Page 18.

# PERFORMANCE DATA

## 60 SIZE

EVAPORATOR AIR		CONDENSER ENTERING AIR TEMPERATURES ° F (° C)																	
		75 (23.9)			85 (29.4)			95 (35)			105 (40.6)			115 (46.1)			125 (51.7)		
		CFM	EWB ° F (° C)	Capacity MBtuh	Total Sys KW	Capacity MBtuh	Total Sys KW	Capacity MBtuh	Total Sys KW	Capacity MBtuh	Total Sys KW	Capacity MBtuh	Total Sys KW	Capacity MBtuh	Total Sys KW	Capacity MBtuh	Total Sys KW		
1750	57 (13.8)	57.04	57.04	3.68	53.71	53.71	4.20	50.37	50.37	4.81	46.94	46.94	5.51	42.94	42.94	6.27	38.22	38.22	7.08
	62 (16.6)	58.59	49.98	3.70	54.72	48.26	4.22	50.83	46.41	4.82	47.02	47.02	5.51	43.00	43.00	6.28	38.29	38.29	7.08
	63* (17.2)	59.69	40.44	3.70	55.67	38.90	4.23	51.62	37.32	4.83	47.50	35.70	5.52	42.48	33.69	6.25	36.58	31.27	7.00
	67 (19.4)	64.43	42.04	3.73	60.26	40.56	4.26	56.00	39.00	4.87	51.67	37.39	5.57	47.05	35.71	6.38	41.05	33.47	7.21
	72 (22.2)	70.39	33.58	3.78	66.06	32.25	4.31	61.55	30.87	4.93	56.94	29.39	5.64	52.21	27.88	6.45	47.19	26.29	7.37
	57 (13.8)	59.44	59.44	3.78	55.93	55.93	4.31	52.41	52.41	4.92	48.83	48.83	5.62	44.92	44.92	6.44	39.97	39.97	7.26
2000	62 (16.6)	60.04	53.50	3.78	56.07	56.07	4.31	52.48	52.48	4.92	48.90	48.90	5.62	44.98	44.98	6.44	40.04	40.04	7.26
	63* (17.2)	60.84	43.04	3.78	56.74	41.49	4.31	52.56	39.87	4.92	48.32	38.18	5.62	43.48	36.25	6.39	37.36	33.66	7.13
	67 (19.4)	65.61	44.79	3.81	61.36	43.29	4.34	56.95	41.68	4.96	52.51	40.02	5.66	47.83	38.30	6.47	41.86	36.09	7.35
	72 (22.2)	71.45	35.11	3.87	67.02	33.78	4.40	62.40	32.37	5.02	57.67	30.89	5.73	52.81	29.36	6.55	47.75	27.77	7.47
	57 (13.8)	61.37	61.37	3.86	57.76	57.76	4.39	54.09	54.09	5.01	50.36	50.36	5.72	46.38	46.38	6.54	41.44	41.44	7.43
	62 (16.6)	61.42	61.42	3.86	57.83	57.83	4.40	54.15	54.15	5.01	50.42	50.42	5.72	46.44	46.44	6.54	41.51	41.51	7.43
2250	63* (17.2)	61.75	45.60	3.86	57.57	43.99	4.39	53.29	42.29	5.00	48.99	40.55	5.71	44.27	38.64	6.52	38.08	35.80	7.26
	67 (19.4)	66.46	47.42	3.89	62.10	45.93	4.43	57.67	44.25	5.04	53.13	42.53	5.75	48.44	40.74	6.56	42.58	38.56	7.48
	72 (22.2)	72.23	36.56	3.95	67.73	35.23	4.48	63.02	33.84	5.11	58.17	32.33	5.82	53.23	30.78	6.65	48.12	29.19	7.57

See Legend and Notes on Page 18.

## PERFORMANCE DATA (CONT)

\* At 75°F (24°C) entering dry bulb—Tennessee Valley Authority (TVA) rating conditions; all others at 80°F dry bulb.

### LEGEND

BF—Bypass Factor  
edb—Entering Dry-Bulb  
Ewb—Entering Wet-Bulb  
kW—Total Unit Power Input  
SHC—Sensible Heat Capacity (1000 Btuh)  
TC—Total Capacity (1000 Btuh) (net)  
rh—Relative Humidity

### COOLING NOTES:

1. Ratings are net; they account for the effects of the evaporator–fan motor power and heat.
2. Direct interpolation is permissible. Do not extrapolate.
3. The following formulas may be used:

$$t_{ldb} = t_{edb} - \frac{\text{Sensible capacity (Btuh)}}{1.10 \times \text{cfm}}$$

$$t_{lwb} = \text{Wet-bulb temperature corresponding to enthalpy air leaving evaporator coil } (h_{lwb})$$

$$h_{lwb} = h_{ewb} - \frac{\text{total capacity (Btuh)}}{4.5 \times \text{cfm}}$$

Where:  $h_{ewb}$  = Enthalpy of air entering evaporator coil

4. The SHC is based on 80°F (26.6°C) edb temperature of air entering evaporator coil. Below 80°F (26.6°C) edb, subtract (corr factor x cfm) from SHC.

Above 80°F (26.6°C) edb, add (corr factor x cfm) to SHC.

Correction Factor =  $1.10 \times (1 + \text{BF}) \times (\text{edb} - 80)$ .

5. Integrated capacity is maximum (instantaneous) capacity less the effect of frost on the outdoor coil and the heat required to defrost it.

## PERFORMANCE DATA (CONT)

### GAS ADJUSTMENT

#### Natural Gas Orifice Sizes and Manifold Pressure – Single Phase Models

Nameplate Input (Btu/hr)		ALTITUDE OF INSTALLATION (FT. ABOVE SEA LEVEL) U.S.A.*				
		0 to 2000 (0–610 m)	2001 to 3000* (611 to 914 m)	3001 to 4000 (915 to 1219 m)	4001 to 5000 (1220 to 1524 m)	5001 to 6000 (1524 to 1829 m)
40000	Orifice No. (Qty)	44 (2)	45 (2)†	48 (2)†	48 (2)†	48 (2)†
	Manifold Press. (in. W.C.)	3.2	3.2	3.8	3.5	3.2
60000	Orifice No. (Qty)	44 (3)	45 (3)†	48 (3)†	48 (3)†	48 (3)†
	Manifold Press. (in. W.C.)	3.2	3.2	3.8	3.5	3.2
90000	Orifice No. (Qty)	38 (3)	41 (3)†	41 (3)†	42 (3)†	42 (3)†
	Manifold Press. (in. W.C.)	3.6	3.8	3.4	3.4	3.2
115000	Orifice No. (Qty)	33 (3)	36 (3)†	36 (3)†	36 (3)†	38 (3)†
	Manifold Press. (in. W.C.)	3.8	3.8	3.6	3.3	3.6
127000	Orifice No. (Qty)	31 (3)	31 (3)	33 (3)†	33 (3)†	34 (3)†
	Manifold Press. (in. W.C.)	3.7	3.2	3.5	3.2	3.2

\*In the U.S.A., the input rating for altitudes above 2000 ft (610m) must be reduced by 4% for each 1000 ft (305 m) above sea level.

In Canada, the input rating for altitudes from 2001 to 4500 ft (611 to 1372 m) above sea level must be derated by 10% by an authorized gas conversion station or dealer. For Canadian Installations from 2000 to 4500 ft, use U.S.A. column 2001 to 3000 ft.

Note: Orifice sizes and manifold pressure settings are based on natural gas with a heating value of 1025 Btu/ft<sup>3</sup> and a specific gravity of .6.

† Orifices available through your distributor.

#### Natural Gas Orifice Sizes and Manifold Pressure – Three Phase Models

Nameplate Input (Btu/hr)		ALTITUDE OF INSTALLATION (FT. ABOVE SEA LEVEL) U.S.A.*				
		0 to 2000 (0–610 m)	2001 to 3000* (611 to 914 m)	3001 to 4000 (915 to 1219 m)	4001 to 5000 (1220 to 1524 m)	5001 to 6000 (1524 to 1829 m)
40000	Orifice No. (Qty)	44 (2)	45 (2)†	48 (2)†	48 (2)†	48 (2)†
	Manifold Press. (in. W.C.)	3.2	3.2	3.8	3.5	3.2
60000	Orifice No. (Qty)	38 (2)	41 (2)†	41 (2)†	42 (2)†	42 (2)†
	Manifold Press. (in. W.C.)	3.6	3.8	3.4	3.4	3.2
90000	Orifice No. (Qty)	38 (3)	41 (3)†	41 (3)†	42 (3)†	42 (3)†
	Manifold Press. (in. W.C.)	3.6	3.8	3.4	3.4	3.2
115000	Orifice No. (Qty)	33 (3)	36 (3)†	36 (3)†	36 (3)†	38 (3)†
	Manifold Press. (in. W.C.)	3.8	3.8	3.6	3.3	3.6
130000	Orifice No. (Qty)	31 (3)	31 (3)	33 (3)†	33 (3)†	34 (3)†
	Manifold Press. (in. W.C.)	3.8	3.2	3.7	3.4	3.3

\*In the U.S.A., the input rating for altitudes above 2000 ft (610m) must be reduced by 4% for each 1000 ft (305 m) above sea level.

In Canada, the input rating for altitudes from 2001 to 4500 ft (611 to 1372 m) above sea level must be derated by 10% by an authorized gas conversion station or dealer. For Canadian Installations from 2000 to 4500 ft, use U.S.A. column 2001 to 3000 ft.

Note: Orifice sizes and manifold pressure settings are based on natural gas with a heating value of 1025 Btu/ft<sup>3</sup> and a specific gravity of .6.

† Orifices available through your distributor.

#### Propane Gas Orifice Sizes and Manifold Pressure – Single Phase Models

Nameplate Input (Btu/hr)		ALTITUDE OF INSTALLATION (FT. ABOVE SEA LEVEL) U.S.A.*				
		0 to 2000 (0–610 m)	2001 to 3000* (611 to 914 m)	3001 to 4000 (915 to 1219 m)	4001 to 5000 (1220 to 1524 m)	5001 to 6000 (1524 to 1829 m)
40000	Orifice No. (Qty)	55 (2)	56 (2)	56 (2)	56 (2)	56 (2)
	Manifold Press. (in. W.C.)	10.0	11.0	11.0	11.0	10.7
60000	Orifice No. (Qty)	55 (3)	56 (3)	56 (3)	56 (3)	56 (3)
	Manifold Press. (in. W.C.)	10.0	11.0	11.0	11.0	10.7
90000	Orifice No. (Qty)	53 (3)	54 (3)	54 (3)	54 (3)	54 (3)
	Manifold Press. (in. W.C.)	10.0	11.0	11.0	11.0	11.0
115000	Orifice No. (Qty)	51 (3)	52 (3)	52 (3)	53 (3)	53 (3)
	Manifold Press. (in. W.C.)	10.0	11.0	10.6	11.0	11.0
127000	Orifice No. (Qty)	49 (3)	50 (3)	51 (3)	52 (3)	52 (3)
	Manifold Press. (in. W.C.)	10.0	11.0	11.0	11.0	11.0

\*In the U.S.A., the input rating for altitudes above 2000 ft (610m) must be reduced by 4% for each 1000 ft (305 m) above sea level.

In Canada, the input rating for altitudes from 2001 to 4500 ft (611 to 1372 m) above sea level must be derated by 10% by an authorized gas conversion station or dealer. For Canadian Installations from 2000 to 4500 ft (610–1372 m), use U.S.A. column 2001 to 3000 ft (611 to 914 m).

† Use Kit No. CPLPCONV013C00 (0–2000 ft [0–610 m] above sea level). Use Kit No. CPLPCONV014C00 (2001–6000 ft [611–1829 m] above sea level).

## Propane Gas Orifice Sizes and Manifold Pressure – Three Phase Models

Nameplate Input (Btu/hr)		ALTITUDE OF INSTALLATION (FT. ABOVE SEA LEVEL) U.S.A.*				
		0 to 2000 (0–610 m)	2001 to 3000* (611 to 914 m)	3001 to 4000 (915 to 1219 m)	4001 to 5000 (1220 to 1524 m)	5001 to 6000 (1524 to 1829 m)
40000	Orifice No. (Qty)	55 (2)	56 (2)	56 (2)	56 (2)	56 (2)
	Manifold Press. (in. W.C.)	10.0	11.0	11.0	11.0	10.7
60000	Orifice No. (Qty)	53 (2)	54 (2)	54 (2)	54 (2)	54 (2)
	Manifold Press. (in. W.C.)	10.0	11.0	11.0	11.0	11.0
90000	Orifice No. (Qty)	53 (3)	54 (3)	54 (3)	54 (3)	54 (3)
	Manifold Press. (in. W.C.)	10.0	11.0	11.0	11.0	11.0
115000	Orifice No. (Qty)	51 (3)	52 (3)	52 (3)	53 (3)	53 (3)
	Manifold Press. (in. W.C.)	10.0	11.0	10.6	11.0	11.0
130000	Orifice No. (Qty)	49 (3)	50 (3)	51 (3)	52 (3)	52 (3)
	Manifold Press. (in. W.C.)	10.0	11.0	11.0	11.0	11.0

\*In the U.S.A., the input rating for altitudes above 2000 ft (610m) must be reduced by 4% for each 1000 ft (305 m) above sea level.

In Canada, the input rating for altitudes from 2001 to 4500 ft (611 to 1372 m) above sea level must be derated by 10% by an authorized gas conversion station or dealer.

For Canadian Installations from 2000 to 4500 ft (610–1372 m), use U.S.A. column 2001 to 3000 ft (611 to 914 m).

†Use Kit No. CPLPCONV013\*00 (0–2000 ft [0–610 m] above sea level). Use Kit No. CPLPCONV014\*00 (2001–6000 ft [611–1829 m] above sea level).

## High Altitude Compensation, Propane Gas – Single Phase Models

Nameplate Input (Btu/hr)	Rated Heating Input (Btu/hr), LP Gas at Installation Altitude Above Sea Level, U.S.A.*				
	0 to 2000 ft (0–610 m)	2001 to 3000 ft* (611 to 914 m)	3001 to 4000 ft (915 to 1219 m)	4001 to 5000 ft (1220 to 1524 m)	5001 to 6000 ft (1524 to 1829 m)
40000	38000	31700	31700	31700	31200
60000	57000	47500	47500	47500	46900
90000	79000	68900	68900	68600	68600
115000	103000	100400	98900	83000	83000
127000	116000	115500	111800	101300	100400

\*In the U.S.A., the input rating for altitudes above 2000 ft (610m) must be reduced by 4% for each 1000 ft (305 m) above sea level.

In Canada, the input rating for altitudes from 2001 to 4500 ft (611 to 1372 m) above sea level must be derated by 10% by an authorized gas conversion station or dealer.

For Canadian Installations from 2000 to 4500 ft (610–1372 m), use U.S.A. column 2001 to 3000 ft (611 to 914 m).

## High Altitude Compensation, Propane Gas – Three Phase Models

Nameplate Input (Btu/hr)	Rated Heating Input (Btu/hr), LP Gas at Installation Altitude Above Sea Level, U.S.A.*				
	0 to 2000 ft (0–610 m)	2001 to 3000 ft* (611 to 914 m)	3001 to 4000 ft (915 to 1219 m)	4001 to 5000 ft (1220 to 1524 m)	5001 to 6000 ft (1524 to 1829 m)
40000	38000	31700	31700	31700	31200
60000	53000	45900	45900	45800	45800
90000	79000	68900	68900	68600	68600
115000	103000	100400	98900	83000	83000
130000	116000	115500	111800	101300	100400

\*In the U.S.A., the input rating for altitudes above 2000 ft (610m) must be reduced by 4% for each 1000 ft (305 m) above sea level.

In Canada, the input rating for altitudes from 2001 to 4500 ft (611 to 1372 m) above sea level must be derated by 10% by an authorized gas conversion station or dealer.

For Canadian Installations from 2000 to 4500 ft (610–1372 m), use U.S.A. column 2001 to 3000 ft (611 to 914 m).

## High Altitude Compensation, Natural Gas – Single Phase Models

Nameplate Input (Btu/hr)	Rated Heating Input (Btu/hr), Natural Gas at Installation Altitude Above Sea Level, U.S.A.*				
	0 to 2000 ft (0–610 m)	2001 to 3000 ft* (611 to 914 m)	3001 to 4000 ft (915 to 1219 m)	4001 to 5000 ft (1220 to 1524 m)	5001 to 6000 ft (1524 to 1829 m)
40000	40000	36000	34400	32800	31200
60000	60000	54000	51600	49200	46800
90000	90000	81000	77400	73800	70200
115000	115000	103500	98900	94300	89700
127000	127000	114300	109200	104100	99100

\*In the U.S.A., the input rating for altitudes above 2000 ft (610m) must be reduced by 4% for each 1000 ft (305 m) above sea level.

In Canada, the input rating for altitudes from 2001 to 4500 ft (611 to 1372 m) above sea level must be derated by 10% by an authorized gas conversion station or dealer.

For Canadian Installations from 2000 to 4500 ft (610–1372 m), use U.S.A. column 2001 to 3000 ft (611 to 914 m).

## High Altitude Compensation, Natural Gas – Three Phase

Nameplate Input (Btu/hr)	Rated Heating Input (Btu/hr), Natural Gas at Installation Altitude Above Sea Level, U.S.A.*				
	0 to 2000 ft (0–610 m)	2001 to 3000 ft* (611 to 914 m)	3001 to 4000 ft (915 to 1219 m)	4001 to 5000 ft (1220 to 1524 m)	5001 to 6000 ft (1524 to 1829 m)
40000	40000	36000	34400	32800	31200
60000	60000	54000	51600	49200	46800
90000	90000	81000	77400	73800	70200
115000	115000	103500	98900	94300	89700
130000	130000	117000	111800	106600	101400

\*In the U.S.A., the input rating for altitudes above 2000 ft (610m) must be reduced by 4% for each 1000 ft (305 m) above sea level.

In Canada, the input rating for altitudes from 2001 to 4500 ft (611 to 1372 m) above sea level must be derated by 10% by an authorized gas conversion station or dealer.

For Canadian Installations from 2000 to 4500 ft (610–1372 m), use U.S.A. column 2001 to 3000 ft (611 to 914 m).

**Dry Coil Air Delivery\* – Horizontal and Downflow Discharge Sizes 24–60 208/230VAC – 1 Phase**

Unit Size	Heating Rise Range °F (°C)	Motor Speed	Wire Color	External Static Pressure (IN. W.C.)																
				0.1	0.2	0.3	0.4	0.5	0.6	0.7	0.8	0.9	1							
24040	Blue	Low <sup>1</sup>	CFM	669	580	525	423	303	---	---	---	---	---	---	---	---	---	---		
			BHP	0.09	0.10	0.11	0.11	0.12	---	---	---	---	---	---	---	---	---	---	---	
			Heat Rise (°F)	44	51	NA	NA	NA	NA	NA	NA	NA	NA	NA	NA	NA	NA	NA	NA	NA
			Heat Rise (°C)	25	29	NA	NA	NA	NA	NA	NA	NA	NA	NA	NA	NA	NA	NA	NA	NA
	Pink	Med–Low <sup>2</sup>	CFM	829	752	680	602	549	455	313	---	---	---	---	---	---	---	---	---	
			BHP	0.14	0.15	0.15	0.16	0.17	0.17	0.18	---	---	---	---	---	---	---	---	---	---
			Heat Rise (°F)	36	40	44	49	54	NA	NA	NA	NA	NA	NA	NA	NA	NA	NA	NA	NA
			Heat Rise (°C)	20	22	24	27	50	NA	NA	NA	NA	NA	NA	NA	NA	NA	NA	NA	NA
	Red	Medium <sup>3</sup>	CFM	1014	929	884	818	746	683	600	537	405	305	---	---	---	---	---	---	
			BHP	0.24	0.24	0.24	0.25	0.26	0.26	0.26	0.27	0.27	0.27	0.29	---	---	---	---	---	---
			Heat Rise (°F)	29	32	34	36	40	44	44	50	55	NA	NA	---	---	---	---	---	---
			Heat Rise (°C)	16	18	19	20	22	24	24	28	31	NA	NA	---	---	---	---	---	---
Orange	Med–High	CFM	1041	972	916	850	782	713	631	581	465	340	---	---	---	---	---	---		
		BHP	0.25	0.26	0.26	0.26	0.26	0.27	0.27	0.28	0.29	0.30	0.31	---	---	---	---	---	---	
		Heat Rise (°F)	29	31	32	35	38	42	42	47	51	NA	NA	---	---	---	---	---	---	
		Heat Rise (°C)	16	17	18	19	21	23	23	26	28	NA	NA	---	---	---	---	---	---	
24060	Black	High	CFM	1187	1124	1061	996	930	896	840	776	698	610	---	---	---	---	---	---	
			BHP	0.36	0.36	0.37	0.37	0.38	0.38	0.38	0.39	0.39	0.39	0.40	---	---	---	---	---	---
			Heat Rise (°F)	25	26	28	30	32	33	33	35	38	43	49	---	---	---	---	---	---
			Heat Rise (°C)	14	15	16	17	18	18	18	20	21	24	27	---	---	---	---	---	---
	Blue	Low <sup>3</sup>	CFM	669	580	525	423	303	---	---	---	---	---	---	---	---	---	---	---	
			BHP	0.09	0.10	0.11	0.11	0.12	---	---	---	---	---	---	---	---	---	---	---	---
			Heat Rise (°F)	NA	NA	NA	NA	NA	NA	NA	NA	NA	NA	NA	---	---	---	---	---	---
			Heat Rise (°C)	NA	NA	NA	NA	NA	NA	NA	NA	NA	NA	NA	---	---	---	---	---	---
	Pink	Med–Low <sup>2</sup>	CFM	829	752	680	602	549	455	313	---	---	---	---	---	---	---	---	---	
			BHP	0.14	0.15	0.15	0.16	0.17	0.17	0.17	0.18	---	---	---	---	---	---	---	---	---
			Heat Rise (°F)	54	NA	NA	NA	NA	NA	NA	NA	NA	NA	NA	---	---	---	---	---	---
			Heat Rise (°C)	30	NA	NA	NA	NA	NA	NA	NA	NA	NA	NA	---	---	---	---	---	---
Red	Medium	CFM	1014	929	884	818	746	683	600	537	405	305	---	---	---	---	---	---		
		BHP	0.24	0.24	0.24	0.25	0.26	0.26	0.26	0.27	0.27	0.27	0.29	---	---	---	---	---	---	
		Heat Rise (°F)	44	48	51	55	NA	NA	NA	NA	NA	NA	NA	---	---	---	---	---	---	
		Heat Rise (°C)	25	27	28	30	NA	NA	NA	NA	NA	NA	NA	---	---	---	---	---	---	
Orange	Med–High <sup>1</sup>	CFM	1041	972	916	850	782	713	631	581	465	340	---	---	---	---	---	---		
		BHP	0.25	0.26	0.26	0.26	0.26	0.27	0.27	0.28	0.29	0.30	0.31	---	---	---	---	---	---	
		Heat Rise (°F)	43	46	49	53	NA	NA	NA	NA	NA	NA	NA	---	---	---	---	---	---	
		Heat Rise (°C)	24	26	27	29	NA	NA	NA	NA	NA	NA	NA	---	---	---	---	---	---	
Black	High	CFM	1187	1124	1061	996	930	896	840	776	698	610	---	---	---	---	---	---		
		BHP	0.36	0.36	0.37	0.37	0.38	0.38	0.38	0.39	0.39	0.39	0.40	---	---	---	---	---	---	
		Heat Rise (°F)	38	40	42	45	48	50	50	53	53	NA	NA	---	---	---	---	---	---	
		Heat Rise (°C)	21	22	23	25	27	28	28	30	30	NA	NA	---	---	---	---	---	---	

**Dry Coil Air Delivery\* – Horizontal and Downflow Discharge Sizes 24–60 208/230VAC – 1 Phase (Cont.)**

Unit Size	Heating Rise Range °F (°C)	Motor Speed	Wire Color	External Static Pressure (IN. W.C.)																			
				0.1	0.2	0.3	0.4	0.5	0.6	0.7	0.8	0.9	1										
30040	25 – 55 (14 – 31)	Low <sup>1</sup>	Blue	CFM	669	580	525	423	303	---	---	---	---	---	---	---	---	---	---	---	---		
				BHP	0.09	0.10	0.11	0.11	0.12	---	---	---	---	---	---	---	---	---	---	---	---	---	---
				Heat Rise (°F)	44	51	NA	NA	NA	NA	NA	NA	NA	NA	NA	NA	NA	NA	NA	NA	NA	NA	NA
		Heat Rise (°C)	25	29	NA	NA	NA	NA	NA	NA	NA	NA	NA	NA	NA	NA	NA	NA	NA	NA	NA	NA	NA
		CFM	829	752	680	602	549	455	313	---	---	---	---	---	---	---	---	---	---	---	---	---	---
		BHP	0.14	0.15	0.15	0.16	0.17	0.17	0.18	---	---	---	---	---	---	---	---	---	---	---	---	---	---
	Heat Rise (°F)	36	40	44	49	54	NA	NA	NA	NA	NA	NA	NA	NA	NA	NA	NA	NA	NA	NA	NA	NA	
	Heat Rise (°C)	20	22	24	27	30	NA	NA	NA	NA	NA	NA	NA	NA	NA	NA	NA	NA	NA	NA	NA	NA	NA
	CFM	1014	929	884	818	746	683	600	537	405	305	---	---	---	---	---	---	---	---	---	---	---	
	BHP	0.24	0.24	0.24	0.25	0.26	0.26	0.27	0.27	0.27	0.29	---	---	---	---	---	---	---	---	---	---	---	
	Heat Rise (°F)	29	32	34	36	40	44	50	55	NA	NA	---	---	---	---	---	---	---	---	---	---	---	
	Heat Rise (°C)	16	18	19	20	22	24	28	31	NA	NA	---	---	---	---	---	---	---	---	---	---	---	
CFM	1041	972	916	850	782	713	631	581	465	340	---	---	---	---	---	---	---	---	---	---	---		
BHP	0.25	0.26	0.26	0.26	0.26	0.27	0.28	0.29	0.30	0.31	---	---	---	---	---	---	---	---	---	---	---		
Heat Rise (°F)	29	31	32	35	38	42	47	51	NA	NA	---	---	---	---	---	---	---	---	---	---	---		
Heat Rise (°C)	16	17	18	19	21	23	26	28	NA	NA	---	---	---	---	---	---	---	---	---	---	---		
CFM	1187	1124	1061	996	930	896	840	776	698	610	---	---	---	---	---	---	---	---	---	---	---		
BHP	0.36	0.36	0.37	0.37	0.38	0.38	0.39	0.39	0.39	0.40	---	---	---	---	---	---	---	---	---	---	---		
Heat Rise (°F)	25	26	28	30	32	33	35	38	43	49	---	---	---	---	---	---	---	---	---	---	---		
Heat Rise (°C)	14	15	16	17	18	18	20	21	24	27	---	---	---	---	---	---	---	---	---	---	---		
CFM	669	580	525	423	303	---	---	---	---	---	---	---	---	---	---	---	---	---	---	---	---		
BHP	0.09	0.10	0.11	0.11	0.12	---	---	---	---	---	---	---	---	---	---	---	---	---	---	---	---		
Heat Rise (°F)	NA	NA	NA	NA	NA	NA	NA	NA	NA	NA	---	---	---	---	---	---	---	---	---	---	---		
Heat Rise (°C)	NA	NA	NA	NA	NA	NA	NA	NA	NA	NA	---	---	---	---	---	---	---	---	---	---	---		
CFM	829	752	680	602	549	455	313	---	---	---	---	---	---	---	---	---	---	---	---	---	---		
BHP	0.14	0.15	0.15	0.16	0.17	0.17	0.18	---	---	---	---	---	---	---	---	---	---	---	---	---	---		
Heat Rise (°F)	54	NA	NA	NA	NA	NA	NA	NA	NA	NA	---	---	---	---	---	---	---	---	---	---	---		
Heat Rise (°C)	30	NA	NA	NA	NA	NA	NA	NA	NA	NA	---	---	---	---	---	---	---	---	---	---	---		
CFM	1014	929	884	818	746	683	600	537	405	305	---	---	---	---	---	---	---	---	---	---	---		
BHP	0.24	0.24	0.24	0.25	0.26	0.26	0.27	0.27	0.27	0.29	---	---	---	---	---	---	---	---	---	---	---		
Heat Rise (°F)	44	48	51	55	NA	NA	NA	NA	NA	NA	---	---	---	---	---	---	---	---	---	---	---		
Heat Rise (°C)	25	27	28	30	NA	NA	NA	NA	NA	NA	---	---	---	---	---	---	---	---	---	---	---		
CFM	1041	972	916	850	782	713	631	581	465	340	---	---	---	---	---	---	---	---	---	---	---		
BHP	0.25	0.26	0.26	0.26	0.26	0.27	0.28	0.29	0.30	0.31	---	---	---	---	---	---	---	---	---	---	---		
Heat Rise (°F)	43	46	49	53	NA	NA	NA	NA	NA	NA	---	---	---	---	---	---	---	---	---	---	---		
Heat Rise (°C)	24	26	27	29	NA	NA	NA	NA	NA	NA	---	---	---	---	---	---	---	---	---	---	---		
CFM	1187	1124	1061	996	930	896	840	776	698	610	---	---	---	---	---	---	---	---	---	---	---		
BHP	0.36	0.36	0.37	0.37	0.38	0.38	0.39	0.39	0.39	0.40	---	---	---	---	---	---	---	---	---	---	---		
Heat Rise (°F)	38	40	42	45	48	50	53	53	NA	NA	---	---	---	---	---	---	---	---	---	---	---		
Heat Rise (°C)	21	22	23	25	27	28	30	30	NA	NA	---	---	---	---	---	---	---	---	---	---	---		

**Dry Coil Air Delivery\* – Horizontal and Downflow Discharge Sizes 24–60 208/230VAC – 1 Phase (Cont.)**

Unit Size	Heating Rise Range °F (°C)	Motor Speed	Wire Color		External Static Pressure (IN. W.C.)											
					0.1	0.2	0.3	0.4	0.5	0.6	0.7	0.8	0.9	1		
36060	25 – 55 (14 – 31)	Low <sup>3</sup>	Blue	CFM	1056	982	911	882	812	740	667	564	486	361		
				BHP	0.24	0.24	0.24	0.26	0.26	0.27	0.28	0.29	0.30	0.30		
				Heat Rise (°F)	42	46	49	51	55	NA	NA	NA	NA	NA	NA	
				Heat Rise (°C)	24	25	27	28	31	NA	NA	NA	NA	NA	NA	
	Med – Low <sup>1</sup>	Pink	Med – Low <sup>1</sup>	Pink	CFM	1174	1107	1045	985	914	890	825	760	673	572	
					BHP	0.32	0.32	0.33	0.33	0.34	0.35	0.36	0.37	0.37	0.37	
					Heat Rise (°F)	38	40	43	46	49	50	54	NA	NA	NA	NA
					Heat Rise (°C)	21	22	24	25	27	28	30	NA	NA	NA	NA
	High	Red	High	Red	CFM	1246	1195	1148	1081	1019	953	884	859	795	690	
					BHP	0.38	0.39	0.39	0.40	0.40	0.41	0.42	0.42	0.42	0.43	
					Heat Rise (°F)	36	38	39	41	44	47	51	52	NA	NA	NA
					Heat Rise (°C)	20	21	22	23	24	26	28	29	NA	NA	NA
36090	35 – 65 (19 – 36)	Med – High	Orange	CFM	1361	1299	1229	1210	1152	1092	1025	958	889	822		
				BHP	0.48	0.49	0.49	0.50	0.50	0.51	0.51	0.51	0.51	0.52		
				Heat Rise (°F)	33	35	36	37	39	41	44	47	50	55		
				Heat Rise (°C)	18	19	20	21	22	23	24	26	28	30		
	High	Black	High	Black	CFM	1596	1542	1482	1424	1362	1304	1238	1173	1201	1143	
					BHP	0.74	0.74	0.74	0.75	0.75	0.75	0.76	0.76	0.77	0.77	
					Heat Rise (°F)	28	29	30	31	33	34	36	38	37	39	
					Heat Rise (°C)	16	16	17	17	18	19	20	21	21	22	
	Med – Low	Blue	Med – Low	Blue	CFM	1056	982	911	882	812	740	667	564	486	361	
					BHP	0.24	0.24	0.24	0.26	0.26	0.27	0.28	0.29	0.30	0.30	
					Heat Rise (°F)	63	NA	NA	NA	NA	NA	NA	NA	NA	NA	
					Heat Rise (°C)	35	NA	NA	NA	NA	NA	NA	NA	NA	NA	
Med – High <sup>1</sup>	Orange	Med – High <sup>1</sup>	Orange	CFM	1174	1107	1045	985	914	890	825	760	673	572		
				BHP	0.32	0.32	0.33	0.33	0.34	0.35	0.36	0.37	0.37	0.37		
				Heat Rise (°F)	57	60	64	NA	NA	NA	NA	NA	NA	NA		
				Heat Rise (°C)	32	34	36	NA	NA	NA	NA	NA	NA	NA		
High	Black	High	Black	CFM	1246	1195	1148	1081	1019	953	884	859	795	690		
				BHP	0.38	0.39	0.39	0.40	0.40	0.41	0.42	0.42	0.42	0.43		
				Heat Rise (°F)	54	56	58	62	NA	NA	NA	NA	NA	NA		
				Heat Rise (°C)	30	31	32	34	NA	NA	NA	NA	NA	NA		

**Dry Coil Air Delivery\* – Horizontal and Downflow Discharge Sizes 24–60 208/230VAC – 1 Phase (Cont.)**

Unit Size	Heating Rise Range °F (°C)	Motor Speed	Wire Color	External Static Pressure (IN. W.C.)											
				0.1	0.2	0.3	0.4	0.5	0.6	0.7	0.8	0.9	1		
42060		Low <sup>3</sup>	Blue	CFM	1001	902	833	777	717	650	575	527	466	419	
				BHP	0.13	0.13	0.14	0.14	0.15	0.16	0.17	0.18	0.19	0.20	
				Heat Rise (°F)	45	50	54	NA	NA	NA	NA	NA	NA	NA	NA
				Heat Rise (°C)	25	28	30	NA	NA	NA	NA	NA	NA	NA	NA
	Med–Low <sup>1</sup>	Pink		CFM	1016	950	902	842	783	721	655	590	541	480	
				BHP	0.13	0.14	0.15	0.16	0.17	0.18	0.19	0.20	0.21	0.22	
				Heat Rise (°F)	44	47	50	53	NA	NA	NA	NA	NA	NA	
				Heat Rise (°C)	25	26	28	30	NA	NA	NA	NA	NA	NA	
	Medium <sup>2</sup>	Red		CFM	1403	1358	1316	1265	1217	1167	1116	1067	1012	956	
				BHP	0.29	0.30	0.31	0.33	0.34	0.35	0.36	0.37	0.38	0.39	
				Heat Rise (°F)	32	33	34	35	37	38	40	42	44	47	
				Heat Rise (°C)	18	18	19	20	20	21	22	23	25	26	
Med–High	Orange		CFM	1461	1411	1367	1327	1275	1220	1174	1127	1074	1022		
			BHP	0.32	0.33	0.35	0.36	0.37	0.38	0.39	0.40	0.41	0.42		
			Heat Rise (°F)	31	32	33	34	35	37	38	40	42	44		
			Heat Rise (°C)	17	18	18	19	20	20	21	22	23	24		
High	Black		CFM	1575	1528	1488	1447	1406	1360	1314	1264	1213	1159		
			BHP	0.40	0.42	0.43	0.44	0.45	0.46	0.47	0.48	0.49	0.50		
			Heat Rise (°F)	28	29	30	31	32	33	34	35	37	39		
			Heat Rise (°C)	16	16	17	17	18	18	19	20	21	21		
42090		Low <sup>3</sup>	Blue	CFM	1001	902	833	777	717	650	575	527	466	419	
				BHP	0.13	0.13	0.14	0.14	0.15	0.16	0.17	0.18	0.19	0.20	
				Heat Rise (°F)	NA	NA	NA	NA	NA	NA	NA	NA	NA	NA	
				Heat Rise (°C)	NA	NA	NA	NA	NA	NA	NA	NA	NA	NA	
	Med–Low	Pink		CFM	1016	950	902	842	783	721	655	590	541	480	
				BHP	0.13	0.14	0.15	0.16	0.17	0.18	0.19	0.20	0.21	0.22	
				Heat Rise (°F)	NA	NA	NA	NA	NA	NA	NA	NA	NA	NA	
				Heat Rise (°C)	NA	NA	NA	NA	NA	NA	NA	NA	NA	NA	
	Medium <sup>2</sup>	Red		CFM	1403	1358	1316	1265	1217	1167	1116	1067	1012	956	
				BHP	0.29	0.30	0.31	0.33	0.34	0.35	0.36	0.37	0.38	0.39	
				Heat Rise (°F)	48	50	51	53	56	58	61	63	NA	NA	
				Heat Rise (°C)	27	28	29	30	31	32	34	35	NA	NA	
Med–High <sup>1</sup>	Orange		CFM	1461	1411	1367	1327	1275	1220	1174	1127	1074	1022		
			BHP	0.32	0.33	0.35	0.36	0.37	0.38	0.39	0.40	0.41	0.42		
			Heat Rise (°F)	46	48	49	51	53	55	58	60	63	NA		
			Heat Rise (°C)	26	27	27	28	29	31	32	33	35	NA		
High	Black		CFM	1575	1528	1488	1447	1406	1360	1314	1264	1213	1159		
			BHP	0.40	0.42	0.43	0.44	0.45	0.46	0.47	0.48	0.49	0.50		
			Heat Rise (°F)	43	44	45	47	48	50	51	54	56	58		
			Heat Rise (°C)	24	25	25	26	27	28	29	30	31	32		

**Dry Coil Air Delivery\* – Horizontal and Downflow Discharge Sizes 24–60 208/230VAC – 1 Phase (Cont.)**

Unit Size	Heating Rise Range °F (°C)	Motor Speed	Wire Color	External Static Pressure (IN. W.C.)									
				0.1	0.2	0.3	0.4	0.5	0.6	0.7	0.8	0.9	1
48090	Low <sup>1</sup>	Blue	CFM	1378	1344	1295	1260	1216	1179	1135	1087	1035	995
			BHP	0.26	0.27	0.29	0.31	0.31	0.33	0.34	0.36	0.36	0.38
			Heat Rise (°F)	49	50	52	54	56	57	60	62	65	NA
			Heat Rise (°C)	27	28	29	30	31	32	33	35	36	NA
	Med–Low <sup>2</sup>	Pink	CFM	1696	1671	1631	1607	1574	1539	1507	1463	1432	1393
			BHP	0.45	0.47	0.49	0.50	0.52	0.52	0.54	0.55	0.57	0.58
			Heat Rise (°F)	40	40	41	42	43	44	45	46	47	49
			Heat Rise (°C)	22	22	23	23	24	24	25	26	26	27
	Medium <sup>3</sup>	Red	CFM	1994	1968	1943	1910	1882	1835	1774	1702	1614	1512
			BHP	0.72	0.73	0.75	0.76	0.78	0.78	0.76	0.73	0.70	0.66
			Heat Rise (°F)	NA	NA	35	35	36	37	38	40	42	45
			Heat Rise (°C)	NA	NA	19	20	20	20	21	22	23	25
Med–High	Orange	CFM	2054	2013	1986	1964	1919	1854	1779	1695	1605	1498	
		BHP	0.77	0.79	0.80	0.82	0.81	0.80	0.76	0.74	0.69	0.65	
		Heat Rise (°F)	NA	NA	NA	NA	35	36	38	40	42	45	
		Heat Rise (°C)	NA	NA	NA	NA	20	20	21	22	23	25	
High	Black	CFM	2267	2201	2133	2071	1997	1923	1835	1739	1654	1551	
		BHP	1.03	1.00	0.97	0.93	0.89	0.86	0.82	0.78	0.74	0.69	
		Heat Rise (°F)	NA	NA	NA	NA	NA	35	37	39	41	44	
		Heat Rise (°C)	NA	NA	NA	NA	NA	20	20	22	23	24	
48115	Low <sup>3</sup>	Blue	CFM	1378	1344	1295	1260	1216	1179	1135	1087	1035	995
			BHP	0.26	0.27	0.29	0.31	0.31	0.33	0.34	0.36	0.36	0.38
			Heat Rise (°F)	NA	NA	NA	NA	NA	NA	NA	NA	NA	NA
			Heat Rise (°C)	NA	NA	NA	NA	NA	NA	NA	NA	NA	NA
	Med–Low <sup>2</sup>	Pink	CFM	1696	1671	1631	1607	1574	1539	1507	1463	1432	1393
			BHP	0.45	0.47	0.49	0.50	0.52	0.52	0.54	0.55	0.57	0.58
			Heat Rise (°F)	51	52	53	54	55	56	57	59	60	NA
			Heat Rise (°C)	28	29	29	30	31	31	32	33	34	NA
	Medium <sup>1</sup>	Red	CFM	1994	1968	1943	1910	1882	1835	1774	1702	1614	1512
			BHP	0.72	0.73	0.75	0.76	0.78	0.78	0.76	0.73	0.70	0.66
			Heat Rise (°F)	43	44	44	45	46	47	49	51	54	57
			Heat Rise (°C)	24	24	25	25	26	26	27	28	30	32
Med–High	Orange	CFM	2054	2013	1986	1964	1919	1854	1779	1695	1605	1498	
		BHP	0.77	0.79	0.80	0.82	0.81	0.80	0.76	0.74	0.69	0.65	
		Heat Rise (°F)	42	43	44	44	45	47	49	51	54	58	
		Heat Rise (°C)	23	24	24	24	25	26	27	28	30	32	
High	Black	CFM	2267	2201	2133	2071	1997	1923	1835	1739	1654	1551	
		BHP	1.03	1.00	0.97	0.93	0.89	0.86	0.82	0.78	0.74	0.69	
		Heat Rise (°F)	38	39	41	42	43	45	47	50	52	56	
		Heat Rise (°C)	21	22	23	23	24	25	26	28	29	31	

**Dry Coil Air Delivery\* – Horizontal and Downflow Discharge Sizes 24–60 208/230VAC – 1 Phase (Cont.)**

Unit Size	Heating Rise Range °F (°C)	Motor Speed	Wire Color	External Static Pressure (IN. W.C.)									
				0.1	0.2	0.3	0.4	0.5	0.6	0.7	0.8	0.9	1
48130	Low <sup>3</sup>	CFM	Blue	1378	1344	1295	1260	1216	1179	1135	1087	1035	995
		BHP	Blue	0.26	0.27	0.29	0.31	0.31	0.33	0.34	0.36	0.36	0.38
		Heat Rise (°F)	Blue	NA	NA	NA	NA	NA	NA	NA	NA	NA	NA
		Heat Rise (°C)	Blue	NA	NA	NA	NA	NA	NA	NA	NA	NA	NA
	Med–Low <sup>2</sup>	CFM	Pink	1696	1671	1631	1607	1574	1539	1507	1463	1432	1393
		BHP	Pink	0.45	0.47	0.49	0.50	0.52	0.52	0.54	0.55	0.57	0.58
		Heat Rise (°F)	Pink	57	57	59	60	61	62	64	64	64	64
		Heat Rise (°C)	Pink	31	32	33	33	34	35	35	35	35	35
	Medium	CFM	Red	1994	1968	1943	1910	1882	1835	1774	1702	1614	1512
		BHP	Red	0.72	0.73	0.75	0.76	0.78	0.78	0.78	0.76	0.73	0.70
		Heat Rise (°F)	Red	48	49	49	50	51	52	54	56	59	63
		Heat Rise (°C)	Red	27	27	27	28	28	29	30	31	33	35
CFM		Orange	2054	2013	1986	1964	1919	1854	1779	1695	1605	1498	
BHP		Orange	0.77	0.79	0.80	0.82	0.81	0.80	0.80	0.76	0.74	0.69	
Heat Rise (°F)		Orange	47	48	48	49	50	52	54	57	60	64	
Heat Rise (°C)		Orange	26	26	27	27	28	29	30	31	33	36	
High	CFM	Black	2267	2201	2133	2071	1997	1923	1835	1739	1654	1551	
	BHP	Black	1.03	1.00	0.97	0.93	0.89	0.86	0.82	0.78	0.74	0.69	
	Heat Rise (°F)	Black	42	44	45	46	48	50	52	55	58	62	
	Heat Rise (°C)	Black	24	24	25	26	27	28	29	31	32	34	
	CFM	Blue	1330	1277	1232	1191	1147	1103	1060	1004	963	919	
	BHP	Blue	0.26	0.27	0.29	0.30	0.31	0.32	0.33	0.34	0.36	0.37	
	Heat Rise (°F)	Blue	51	53	55	57	59	61	64	64	64	64	
	Heat Rise (°C)	Blue	28	29	31	32	33	34	35	35	35	35	
60090	Med–Low <sup>1</sup>	CFM	Pink	1475	1436	1399	1351	1317	1270	1236	1188	1152	1105
		BHP	Pink	0.35	0.36	0.37	0.38	0.40	0.41	0.42	0.43	0.45	0.45
		Heat Rise (°F)	Pink	46	47	48	50	51	53	55	57	59	61
		Heat Rise (°C)	Pink	25	26	27	28	29	30	30	32	33	34
	Medium <sup>2</sup>	CFM	Red	1736	1710	1668	1630	1600	1557	1522	1479	1450	1406
		BHP	Red	0.53	0.54	0.55	0.58	0.59	0.60	0.62	0.63	0.64	0.65
		Heat Rise (°F)	Red	39	40	41	42	42	43	44	46	47	48
		Heat Rise (°C)	Red	22	22	23	23	23	24	25	25	26	27
	Med–High	CFM	Orange	1935	1909	1867	1836	1808	1766	1696	1619	1535	1454
		BHP	Orange	0.71	0.73	0.74	0.76	0.78	0.79	0.77	0.75	0.72	0.68
		Heat Rise (°F)	Orange	35	35	36	37	37	38	40	42	44	47
		Heat Rise (°C)	Orange	19	20	20	20	21	21	22	23	24	26
High	CFM	Black	2205	2150	2078	2011	1941	1852	1779	1672	1572	1473	
	BHP	Black	1.04	1.02	0.99	0.95	0.92	0.87	0.85	0.79	0.75	0.70	
	Heat Rise (°F)	Black	NA	NA	NA	NA	NA	35	37	40	43	46	
	Heat Rise (°C)	Black	NA	NA	NA	NA	19	20	21	22	24	26	

**Dry Coil Air Delivery\* – Horizontal and Downflow Discharge Sizes 24–60 208/230VAC – 1 Phase (Cont.)**

Unit Size	Heating Rise Range °F (°C)	Motor Speed	Wire Color	External Static Pressure (IN. W.C.)												
				0.1	0.2	0.3	0.4	0.5	0.6	0.7	0.8	0.9	1			
60115	30 – 60 (17 – 33)	Low <sup>3</sup>	Blue	CFM	1330	1277	1232	1191	1147	1103	1060	1004	963	919		
				BHP	0.26	0.27	0.29	0.30	0.31	0.32	0.33	0.34	0.36	0.37		
				Heat Rise (°F)	NA	NA	NA	NA	NA	NA	NA	NA	NA	NA	NA	
				Heat Rise (°C)	NA	NA	NA	NA	NA	NA	NA	NA	NA	NA	NA	
	Med–Low	Pink	Med–Low	Pink	CFM	1475	1436	1399	1351	1317	1270	1236	1188	1152	1105	
					BHP	0.35	0.36	0.37	0.38	0.40	0.41	0.42	0.43	0.45	0.45	
					Heat Rise (°F)	59	60	NA	NA	NA	NA	NA	NA	NA	NA	NA
					Heat Rise (°C)	33	33	NA	NA	NA	NA	NA	NA	NA	NA	NA
	Medium <sup>2</sup>	Red	Medium <sup>2</sup>	Red	CFM	1736	1710	1668	1630	1600	1557	1522	1479	1450	1406	
					BHP	0.53	0.54	0.55	0.58	0.59	0.60	0.62	0.63	0.64	0.65	
					Heat Rise (°F)	50	51	52	53	54	56	57	58	60	NA	
					Heat Rise (°C)	28	28	29	29	30	31	32	32	33	NA	
Med–High <sup>1</sup>	Orange	Med–High <sup>1</sup>	Orange	CFM	1935	1909	1867	1836	1808	1766	1696	1619	1535	1454		
				BHP	0.71	0.73	0.74	0.76	0.78	0.79	0.77	0.75	0.72	0.68		
				Heat Rise (°F)	45	45	46	47	48	49	51	53	56	59		
				Heat Rise (°C)	25	25	26	26	27	27	28	30	31	33		
60130	35 – 65 (19 – 36)	Low <sup>3</sup>	Blue	CFM	2205	2150	2078	2011	1941	1852	1779	1672	1572	1473		
				BHP	1.04	1.02	0.99	0.95	0.92	0.87	0.85	0.79	0.75	0.70		
				Heat Rise (°F)	39	40	42	43	45	47	49	52	55	59		
				Heat Rise (°C)	22	22	23	24	25	26	27	29	31	33		
	Med–Low	Pink	Med–Low	Pink	CFM	1330	1277	1232	1191	1147	1103	1060	1004	963	919	
					BHP	0.26	0.27	0.29	0.30	0.31	0.32	0.33	0.34	0.36	0.37	
					Heat Rise (°F)	NA	NA	NA	NA	NA	NA	NA	NA	NA	NA	
					Heat Rise (°C)	NA	NA	NA	NA	NA	NA	NA	NA	NA	NA	
	Medium <sup>2</sup>	Red	Medium <sup>2</sup>	Red	CFM	1475	1436	1399	1351	1317	1270	1236	1188	1152	1105	
					BHP	0.35	0.36	0.37	0.38	0.40	0.41	0.42	0.43	0.45	0.45	
					Heat Rise (°F)	65	NA	NA	NA	NA	NA	NA	NA	NA	NA	
					Heat Rise (°C)	36	NA	NA	NA	NA	NA	NA	NA	NA	NA	
Med–High <sup>1</sup>	Orange	Med–High <sup>1</sup>	Orange	CFM	1736	1710	1668	1630	1600	1557	1522	1479	1450	1406		
				BHP	0.53	0.54	0.55	0.58	0.59	0.60	0.62	0.63	0.64	0.65		
				Heat Rise (°F)	55	56	57	59	60	62	63	65	NA	NA		
				Heat Rise (°C)	31	31	32	33	33	34	35	36	NA	NA		
High	Black	High	Black	CFM	1935	1909	1867	1836	1808	1766	1696	1619	1535	1454		
				BHP	0.71	0.73	0.74	0.76	0.78	0.79	0.77	0.75	0.72	0.68		
				Heat Rise (°F)	50	50	51	52	53	54	57	59	62	NA		
				Heat Rise (°C)	28	28	29	29	29	30	31	33	35	NA		

\*Air delivery values are without air filter and are for dry coil (See Wet Coil Pressure Drop table).

<sup>1</sup> Factory-shipped heating speed

<sup>2</sup> Factory-shipped cooling speed

<sup>3</sup> Factory-shipped continuous fan speed

"NA" = Not allowed for heating speed

**NOTE:** Deduct field-supplied air filter pressure drop and wet coil pressure drop to obtain external static pressure available for ducting. Shaded areas indicate speed/static combinations that are not permitted for dehumidification speed.

**Dry Coil Air Delivery\* – Horizontal Discharge – Sizes 36–60 3 Phase Models Only**

Unit	Heating Rise Range	Motor Speed	Wire Color	CFM	External Static Pressure (IN. W.C.)											
					0.1	0.2	0.3	0.4	0.5	0.6	0.7	0.8	0.9			
36060	25 – 55°F (14 – 31°C)	Low	Blue	CFM	979	912	859	789	731	654	556	454	374			
				Heating Rise (°F)	45	48	51	NA	NA	NA	NA	NA	NA	NA	NA	NA
				Heating Rise (°C)	25	27	28	NA	NA	NA	NA	NA	NA	NA	NA	NA
				CFM	1136	1080	1015	957	912	861	808	723	633			
				Heating Rise (°F)	39	41	43	46	48	51	54	NA	NA	NA	NA	
				Heating Rise (°C)	22	23	24	26	27	28	30	NA	NA	NA	NA	
		Med–Low <sup>1</sup>	Red	Medium <sup>2</sup>	CFM	1208	1144	1091	1025	964	902	886	830	746		
					Heating Rise (°F)	36	38	40	43	46	49	50	53	NA	NA	
					Heating Rise (°C)	20	21	22	24	25	27	28	29	NA	NA	
					CFM	1495	1439	1376	1303	1221	1207	1137	1052	981		
					Heating Rise (°F)	29	31	32	34	36	36	39	42	45		
					Heating Rise (°C)	16	17	18	19	20	20	22	23	25		
36090	35 – 65°F (19 – 36°C)	High	Black	CFM	1560	1491	1416	1337	1255	1233	1160	1082	998			
				Heating Rise (°F)	28	30	31	33	35	36	38	41	44			
				Heating Rise (°C)	16	16	17	18	19	20	21	23	24			
				CFM	979	912	859	789	731	654	556	454	374			
				Heating Rise (°F)	NA	NA	NA	NA	NA	NA	NA	NA	NA	NA		
				Heating Rise (°C)	NA	NA	NA	NA	NA	NA	NA	NA	NA	NA		
		Med–Low	Pink	Medium <sup>2</sup>	CFM	1136	1080	1015	957	912	861	808	723	633		
					Heating Rise (°F)	58	61	65	NA	NA	NA	NA	NA	NA	NA	
					Heating Rise (°C)	32	34	36	NA	NA	NA	NA	NA	NA	NA	
					CFM	1208	1144	1091	1025	964	902	886	830	746		
					Heating Rise (°F)	54	58	60	64	NA	NA	NA	NA	NA	NA	
					Heating Rise (°C)	30	32	34	36	NA	NA	NA	NA	NA	NA	
42060	25 – 55°F (14 – 31°C)	Med–High <sup>1</sup>	Orange	CFM	1495	1439	1376	1303	1221	1207	1137	1052	981			
				Heating Rise (°F)	44	46	48	51	54	55	58	63	NA	NA		
				Heating Rise (°C)	24	25	27	28	30	30	32	35	NA	NA		
				CFM	1560	1491	1416	1337	1255	1233	1160	1082	998			
				Heating Rise (°F)	42	44	46	49	52	53	57	61	NA	NA		
				Heating Rise (°C)	23	25	26	27	29	30	32	34	NA	NA		
		High	Black	Medium <sup>2</sup>	CFM	952	882	806	746	671	605	530	486			
					Heating Rise (°F)	46	49	54	NA	NA	NA	NA	NA	NA		
					Heating Rise (°C)	25	27	30	NA	NA	NA	NA	NA	NA		
					CFM	1002	936	875	821	748	687	613	554	565		
					Heating Rise (°F)	43	46	50	53	NA	NA	NA	NA	NA	NA	
					Heating Rise (°C)	24	26	28	29	NA	NA	NA	NA	NA	NA	
42090	35 – 65°F (19 – 36°C)	Low	Blue	CFM	1255	1210	1145	1074	1008	940	878	895	838			
				Heating Rise (°F)	35	36	38	40	43	46	49	48	52			
				Heating Rise (°C)	19	20	21	22	24	26	27	27	29			
				CFM	1335	1267	1246	1176	1109	1049	988	926	872			
				Heating Rise (°F)	32	34	35	37	39	41	44	47	50			
				Heating Rise (°C)	18	19	19	20	22	23	24	26	28			
		Med–Low <sup>1</sup>	Pink	Medium	CFM	1472	1401	1326	1251	1275	1198	1139	1085	1023		
					Heating Rise (°F)	29	31	33	35	34	36	38	40	42		
					Heating Rise (°C)	16	17	18	19	19	20	21	22	24		
					CFM	1560	1491	1416	1337	1255	1233	1160	1082	998		
					Heating Rise (°F)	28	30	31	33	35	36	38	41	44		
					Heating Rise (°C)	16	16	17	18	19	20	21	23	24		

**Dry Coil Air Delivery\* – Horizontal Discharge Sizes 36–60 3 Phase Models Only (Cont.)**

Unit	Heating Rise Range	Motor Speed	Wire Color	External Static Pressure (IN. W.C.)										
				0.1	0.2	0.3	0.4	0.5	0.6	0.7	0.8	0.9		
42090	35 – 65°F (19 – 36°C)	Low	Blue	CFM	952	882	806	746	671	605	530	551	486	
				Heating Rise (°F)	NA	NA	NA	NA	NA	NA	NA	NA	NA	NA
				Heating Rise (°C)	NA	NA	NA	NA	NA	NA	NA	NA	NA	NA
				CFM	1002	936	875	821	748	687	613	554	565	
				Heating Rise (°F)	NA	NA	NA	NA	NA	NA	NA	NA	NA	NA
				Heating Rise (°C)	NA	NA	NA	NA	NA	NA	NA	NA	NA	NA
				CFM	1255	1210	1145	1074	1008	940	878	895	838	
				Heating Rise (°F)	53	55	58	62	NA	NA	NA	NA	NA	
				Heating Rise (°C)	30	31	32	35	NA	NA	NA	NA	NA	
				CFM	1335	1267	1246	1176	1109	1049	988	926	872	
Heating Rise (°F)	50	53	54	57	60	64	NA	NA	NA					
Heating Rise (°C)	28	29	30	32	34	35	NA	NA	NA					
CFM	1472	1401	1326	1251	1275	1198	1139	1085	1023					
Heating Rise (°F)	45	48	50	53	52	56	59	62	65					
Heating Rise (°C)	25	27	28	30	29	31	33	34	36					
CFM	1402	1351	1311	1263	1224	1172	1136	1080	1041					
Heating Rise (°F)	48	50	51	53	55	57	59	62	64					
Heating Rise (°C)	27	28	28	29	30	32	33	34	36					
CFM	1457	1404	1367	1318	1284	1233	1197	1144	1104					
Heating Rise (°F)	46	48	49	51	52	54	56	58	61					
Heating Rise (°C)	26	26	27	28	29	30	31	32	34					
CFM	1736	1695	1642	1601	1553	1512	1465	1427	1381					
Heating Rise (°F)	39	39	41	42	43	44	46	47	48					
Heating Rise (°C)	21	22	23	23	24	25	25	26	27					
CFM	2149	2111	2062	2026	1980	1945	1905	1864	1793					
Heating Rise (°F)	NA	NA	NA	NA	NA	NA	35	36	37					
Heating Rise (°C)	NA	NA	NA	NA	NA	NA	20	20	21					
CFM	2344	2306	2259	2203	2141	2070	1991	1902	1803					
Heating Rise (°F)	NA	NA	NA	NA	NA	NA	NA	35	37					
Heating Rise (°C)	NA	NA	NA	NA	NA	NA	NA	20	21					
CFM	1402	1351	1311	1263	1224	1172	1136	1080	1041					
Heating Rise (°F)	NA	NA	NA	NA	NA	NA	NA	NA	NA					
Heating Rise (°C)	NA	NA	NA	NA	NA	NA	NA	NA	NA					
CFM	1457	1404	1367	1318	1284	1233	1197	1144	1104					
Heating Rise (°F)	58	NA	NA	NA	NA	NA	NA	NA	NA					
Heating Rise (°C)	32	NA	NA	NA	NA	NA	NA	NA	NA					
CFM	1736	1695	1642	1601	1553	1512	1465	1427	1381					
Heating Rise (°F)	49	50	52	53	55	56	58	60	NA					
Heating Rise (°C)	27	28	29	30	30	31	32	33	NA					
CFM	2149	2111	2062	2026	1980	1945	1905	1864	1793					
Heating Rise (°F)	40	40	41	42	43	44	45	46	48					
Heating Rise (°C)	22	22	23	23	24	24	25	25	26					
CFM	2344	2306	2259	2203	2141	2070	1991	1902	1803					
Heating Rise (°F)	36	37	38	39	40	41	43	45	47					
Heating Rise (°C)	20	21	21	21	22	23	24	25	26					

**Dry Coil Air Delivery\* – Horizontal Discharge Sizes 36–60 3 Phase Models Only (Cont.)**

Unit	Heating Rise Range	Motor Speed	Wire Color	CFM	External Static Pressure (IN. W.C.)												
					0.1	0.2	0.3	0.4	0.5	0.6	0.7	0.8	0.9				
48130	35 – 65°F (19 – 36°C)	Low	Blue	CFM	1402	1351	1311	1263	1224	1172	1136	1080	1041				
				Heating Rise (°F)	NA	NA	NA	NA	NA	NA	NA	NA	NA	NA	NA	NA	
				Heating Rise (°C)	NA	NA	NA	NA	NA	NA	NA	NA	NA	NA	NA	NA	NA
				CFM	1457	1404	1367	1318	1284	1233	1197	1144	1104				
				Heating Rise (°F)	65	NA	NA	NA	NA	NA	NA	NA	NA	NA	NA	NA	
				Heating Rise (°C)	36	NA	NA	NA	NA	NA	NA	NA	NA	NA	NA	NA	
		Med–Low	Red	Medium <sup>2</sup>	Red	CFM	1736	1695	1642	1601	1553	1512	1465	1427	1381		
						Heating Rise (°F)	55	56	58	59	61	63	65	NA	NA	NA	
						Heating Rise (°C)	30	31	32	33	34	35	36	NA	NA	NA	
						CFM	2149	2111	2062	2026	1980	1945	1905	1864	1793		
						Heating Rise (°F)	44	45	46	47	48	49	50	51	53		
						Heating Rise (°C)	25	25	26	26	27	27	28	28	29		
60090	35 – 65°F (19 – 36°C)	Med–High <sup>1</sup>	Orange	CFM	2344	2306	2259	2203	2141	2070	1991	1902	1803				
				Heating Rise (°F)	41	41	42	43	44	46	48	50	53				
				Heating Rise (°C)	23	23	23	24	25	26	27	28	29				
				CFM	1445	1389	1341	1281	1236	1189	1139	1072	1027				
				Heating Rise (°F)	46	48	50	52	54	56	59	62	65				
				Heating Rise (°C)	26	27	28	29	30	31	33	35	36				
		High	Black	High	Black	CFM	1678	1635	1602	1558	1513	1474	1438	1404	1349		
						Heating Rise (°F)	40	41	42	43	44	45	47	48	50		
						Heating Rise (°C)	22	23	23	24	25	25	26	26	28		
						CFM	1962	1915	1880	1843	1794	1753	1711	1675	1628		
						Heating Rise (°F)	NA	35	36	36	37	38	39	40	41		
						Heating Rise (°C)	NA	19	20	20	21	21	22	22	23		
Med–Low	Blue	Low <sup>1</sup>	Blue	CFM	2131	2088	2065	2013	1982	1941	1888	1860	1785				
				Heating Rise (°F)	NA	NA	NA	NA	NA	NA	35	36	37				
				Heating Rise (°C)	NA	NA	NA	NA	NA	NA	20	20	21				
				CFM	2461	2409	2339	2286	2192	2140	2062	1968	1874				
				Heating Rise (°F)	NA	NA	NA	NA	NA	NA	NA	NA	36				
				Heating Rise (°C)	NA	NA	NA	NA	NA	NA	NA	NA	20				
Med–High	Red	Medium <sup>2</sup>	Red	CFM	2131	2088	2065	2013	1982	1941	1888	1860	1785				
				Heating Rise (°F)	NA	NA	NA	NA	NA	NA	35	36	37				
				Heating Rise (°C)	NA	NA	NA	NA	NA	NA	20	20	21				
				CFM	2461	2409	2339	2286	2192	2140	2062	1968	1874				
				Heating Rise (°F)	NA	NA	NA	NA	NA	NA	NA	NA	36				
				Heating Rise (°C)	NA	NA	NA	NA	NA	NA	NA	NA	20				

Specifications subject to change without notice.

**Dry Coil Air Delivery\* – Horizontal Discharge Sizes 36–60 3 Phase Models Only (Cont.)**

Unit	Heating Rise Range	Motor Speed	Wire Color	External Static Pressure (IN. W.C.)										
				0.1	0.2	0.3	0.4	0.5	0.6	0.7	0.8	0.9		
60115	30 – 60°F (17 – 33°C)	Low	Blue	CFM	1445	1389	1341	1281	1236	1189	1139	1072	1027	
				Heating Rise (°F)	59	NA	NA	NA	NA	NA	NA	NA	NA	NA
		Med–Low	Pink	CFM	1678	1635	1602	1558	1513	1474	1438	1404	1349	
				Heating Rise (°F)	51	52	53	55	56	58	59	NA	NA	
		Medium <sup>2</sup>	Red	CFM	1962	1915	1880	1843	1794	1753	1711	1675	1628	
				Heating Rise (°F)	43	44	45	46	47	49	50	51	52	
		Med–High <sup>1</sup>	Orange	CFM	2131	2088	2065	2013	1982	1941	1888	1860	1785	
				Heating Rise (°F)	40	41	41	42	43	44	45	46	48	
		High	Black	CFM	2461	2409	2339	2286	2192	2140	2062	1968	1874	
				Heating Rise (°F)	35	35	36	37	39	40	41	43	45	
60130	35 – 65°F (19 – 36°C)	Low	Blue	CFM	1445	1389	1341	1281	1236	1189	1139	1072	1027	
				Heating Rise (°F)	NA	NA	NA	NA	NA	NA	NA	NA	NA	
		Med–Low	Pink	CFM	1678	1635	1602	1558	1513	1474	1438	1404	1349	
				Heating Rise (°F)	57	58	59	61	63	65	65	NA	NA	
		Medium <sup>2</sup>	Red	CFM	1962	1915	1880	1843	1794	1753	1711	1675	1628	
				Heating Rise (°F)	49	50	51	52	53	54	56	57	58	
		Med–High <sup>1</sup>	Orange	CFM	2131	2088	2065	2013	1982	1941	1888	1860	1785	
				Heating Rise (°F)	45	46	46	47	48	49	50	51	53	
		High	Black	CFM	2461	2409	2339	2286	2192	2140	2062	1968	1874	
				Heating Rise (°F)	39	40	41	42	43	44	46	48	51	

\*Air delivery values are without air filter and are for dry coil (See Wet Coil Pressure Drop table).

<sup>1</sup> Factory-shipped heating speed

<sup>2</sup> Factory-shipped cooling speed

"NA" = Not allowed for heating speed

Note: Ductwork field-supplied air filter pressure drop and wet coil pressure drop to obtain external static pressure available for ducting.

Shaded areas indicate speed/static combinations that are not permitted for dehumidification speed.

**Dry Coil Air Delivery – Downflow Discharge Sizes 36–60 3 Phase Models Only**

Unit	Heating Rise Range	Motor Speed	Wire Color	External Static Pressure (IN. W.C.)										
				0.1	0.2	0.3	0.4	0.5	0.6	0.7	0.8	0.9	1.0	
36060	25 – 55°F (14 – 31°C)	Low	Blue	CFM	979	912	859	789	731	654	556	454	374	255
				WATTS	202	212	217	221	231	236	245	251	259	253
				BHP	0.22	0.23	0.23	0.24	0.25	0.25	0.26	0.27	0.28	0.27
		Heating Rise (°F)	45	48	51	NA	NA	NA	NA	NA	NA	NA	NA	NA
		Heating Rise (°C)	25	27	28	NA	NA	NA	NA	NA	NA	NA	NA	NA
		Med–Low <sup>1</sup>	CFM	1136	1080	1015	957	912	861	808	723	633	545	
	WATTS		294	309	310	322	325	333	341	349	354	367		
	BHP		0.32	0.33	0.33	0.35	0.35	0.36	0.37	0.37	0.38			
	Heating Rise (°F)		39	41	43	46	48	51	54	NA	NA	NA		
	Heating Rise (°C)		22	23	24	26	27	28	30	NA	NA	NA		
	Medium <sup>2</sup>		CFM	1208	1144	1091	1025	964	902	886	830	746	663	
		WATTS	345	350	358	366	373	377	390	396	407	410		
BHP		0.37	0.38	0.38	0.39	0.40	0.40	0.42	0.42	0.44	0.44			
Heating Rise (°F)		36	38	40	43	46	49	50	53	NA	NA			
Heating Rise (°C)		20	21	22	24	25	27	28	29	NA	NA			
Med–High		CFM	1495	1439	1376	1303	1221	1207	1137	1052	981	894		
	WATTS	625	634	635	633	624	613	598	583	573	551			
	BHP	0.67	0.68	0.68	0.68	0.67	0.66	0.64	0.63	0.61	0.59			
	Heating Rise (°F)	29	31	32	34	36	36	39	42	45	49			
	Heating Rise (°C)	16	17	18	19	20	20	22	23	25	27			
	36090	35 – 65°F (19 – 36°C)	High	Black	CFM	1560	1491	1416	1337	1255	1233	1160	1082	998
WATTS					708	699	683	674	660	634	624	606	581	566
BHP					0.76	0.75	0.73	0.72	0.71	0.68	0.67	0.65	0.62	0.61
Heating Rise (°F)			28	30	31	33	35	36	38	41	44	48		
Heating Rise (°C)			16	16	17	18	19	20	21	23	24	27		
Med–Low			CFM	979	912	859	789	731	654	556	454	374	255	
		WATTS	202	212	217	221	231	236	245	251	259	253		
		BHP	0.22	0.23	0.23	0.24	0.25	0.25	0.26	0.27	0.28	0.27		
		Heating Rise (°F)	NA	NA	NA	NA	NA	NA	NA	NA	NA	NA		
		Heating Rise (°C)	NA	NA	NA	NA	NA	NA	NA	NA	NA	NA		
		Med–Low	CFM	1136	1080	1015	957	912	861	808	723	633	545	
WATTS			294	309	310	322	325	333	341	349	354	367		
BHP	0.32		0.33	0.33	0.35	0.35	0.36	0.37	0.37	0.38				
Heating Rise (°F)	58		61	NA	NA	NA	NA	NA	NA	NA	NA			
Heating Rise (°C)	32		34	NA	NA	NA	NA	NA	NA	NA	NA			
Medium <sup>2</sup>	CFM		1208	1144	1091	1025	964	902	886	830	746	663		
	WATTS	345	350	358	366	373	377	390	396	407	410			
	BHP	0.37	0.38	0.38	0.39	0.40	0.40	0.42	0.42	0.44	0.44			
	Heating Rise (°F)	54	58	60	64	NA	NA	NA	NA	NA	NA			
	Heating Rise (°C)	30	32	34	36	NA	NA	NA	NA	NA	NA			
	Med–High <sup>1</sup>	CFM	1495	1439	1376	1303	1221	1207	1137	1052	981	894		
WATTS		625	634	635	633	624	613	598	583	573	551			
BHP		0.67	0.68	0.68	0.68	0.67	0.66	0.64	0.63	0.61	0.59			
Heating Rise (°F)		44	46	48	51	54	55	58	63	NA	NA			
Heating Rise (°C)		24	25	27	28	30	30	32	35	NA	NA			
High <sup>1</sup>		CFM	1560	1491	1416	1337	1255	1233	1160	1082	998	911		
	WATTS	708	699	683	674	660	634	624	606	581	566			
	BHP	0.76	0.75	0.73	0.72	0.71	0.68	0.67	0.65	0.62	0.61			
	Heating Rise (°F)	42	44	46	49	52	53	57	61	NA	NA			
	Heating Rise (°C)	23	25	26	27	29	30	32	34	NA	NA			

**Dry Coil Air Delivery – Downflow Discharge Sizes 36–60 3 Phase Models Only (Cont.)**

Unit	Heating Rise Range	Motor Speed	Wire Color	External Static Pressure (IN. W.C.)										
				0.1	0.2	0.3	0.4	0.5	0.6	0.7	0.8	0.9	1.0	
42060	25 – 55°F (14 – 31°C)	Low	Blue	CFM	952	882	806	746	671	605	530	551	486	435
				WATTS	124	134	140	150	156	166	171	182	188	198
				BHP	0.13	0.14	0.15	0.16	0.17	0.18	0.18	0.20	0.20	0.21
				Heating Rise (°F)	45	49	54	NA	NA	NA	NA	NA	NA	NA
		Heating Rise (°C)	25	27	30	NA	NA	NA	NA	NA	NA	NA		
		Med–Low <sup>1</sup>	Pink	CFM	1002	936	875	821	748	687	613	554	565	518
				WATTS	144	155	161	171	176	187	193	203	209	220
				BHP	0.15	0.17	0.17	0.18	0.19	0.20	0.21	0.22	0.22	0.24
				Heating Rise (°F)	43	46	49	53	NA	NA	NA	NA	NA	NA
		Heating Rise (°C)	24	26	27	29	NA	NA	NA	NA	NA	NA		
		Medium	Red	CFM	1255	1210	1145	1074	1008	940	878	895	838	785
				WATTS	249	272	284	292	305	319	320	329	336	347
				BHP	0.27	0.29	0.30	0.31	0.33	0.34	0.34	0.35	0.36	0.37
				Heating Rise (°F)	35	36	38	40	43	46	49	48	52	55
		Heating Rise (°C)	19	20	21	22	24	26	27	27	29	31		
		Med–High <sup>2</sup>	Orange	CFM	1335	1267	1246	1176	1109	1049	988	926	872	891
WATTS	311			323	330	342	356	367	378	385	395	403		
BHP	0.33			0.35	0.35	0.37	0.38	0.39	0.41	0.41	0.42	0.43		
Heating Rise (°F)	32			34	35	37	39	41	44	47	50	49		
Heating Rise (°C)	18	19	19	20	22	23	24	26	28	27				
High	Black	CFM	1472	1401	1326	1251	1198	1139	1085	1023	961			
		WATTS	401	414	426	440	471	462	473	478	486	491		
		BHP	0.43	0.44	0.46	0.47	0.51	0.50	0.51	0.51	0.52	0.53		
		Heating Rise (°F)	29	31	33	35	34	36	38	40	42	45		
Heating Rise (°C)	16	17	18	19	19	20	21	22	24	25				
42090	35 – 65°F (19 – 36°C)	Low	Blue	CFM	952	882	806	746	671	605	530	551	486	435
				WATTS	124	134	140	150	156	166	171	182	188	198
				BHP	0.13	0.14	0.15	0.16	0.17	0.18	0.18	0.20	0.20	0.21
				Heating Rise (°F)	NA	NA	NA	NA	NA	NA	NA	NA	NA	NA
		Heating Rise (°C)	NA	NA	NA	NA	NA	NA	NA	NA	NA	NA		
		Med–Low	Pink	CFM	1002	936	875	821	748	687	613	554	565	518
				WATTS	144	155	161	171	176	187	193	203	209	220
				BHP	0.15	0.17	0.17	0.18	0.19	0.20	0.21	0.22	0.22	0.24
				Heating Rise (°F)	NA	NA	NA	NA	NA	NA	NA	NA	NA	NA
		Heating Rise (°C)	NA	NA	NA	NA	NA	NA	NA	NA	NA	NA		
		Medium <sup>1</sup>	Red	CFM	1255	1210	1145	1074	1008	940	878	895	838	785
				WATTS	249	272	284	292	305	319	320	329	336	347
				BHP	0.27	0.29	0.30	0.31	0.33	0.34	0.34	0.35	0.36	0.37
				Heating Rise (°F)	53	55	58	62	NA	NA	NA	NA	NA	NA
		Heating Rise (°C)	30	31	32	35	NA	NA	NA	NA	NA	NA		
		Med–High <sup>2</sup>	Orange	CFM	1335	1267	1246	1176	1109	1049	988	926	872	891
WATTS	311			323	330	342	356	367	378	385	395	403		
BHP	0.33			0.35	0.35	0.37	0.38	0.39	0.41	0.41	0.42	0.43		
Heating Rise (°F)	47			48	50	53	54	57	60	64	NA	NA		
Heating Rise (°C)	28	29	30	32	34	35	35	35	NA	NA				
High	Black	CFM	1472	1401	1326	1251	1198	1139	1085	1023	961			
		WATTS	401	414	426	440	471	462	473	478	486	491		
		BHP	0.43	0.44	0.46	0.47	0.51	0.50	0.51	0.51	0.52	0.53		
		Heating Rise (°F)	45	48	50	53	52	56	59	62	65	NA		
Heating Rise (°C)	25	27	28	30	29	31	33	34	36	NA				

**Dry Coil Air Delivery – Downflow Discharge Sizes 36–60 3 Phase Models Only (Cont.)**

Unit	Heating Rise Range	Motor Speed	Wire Color	External Static Pressure (IN. W.C.)																				
				0.1	0.2	0.3	0.4	0.5	0.6	0.7	0.8	0.9	1.0											
48090	35 – 65°F (19 – 36°C)	Low <sup>1</sup>	Blue	CFM	1503	1457	1423	1374	1330	1287	1241	1199	1153	1111										
				WATTS	225	233	246	254	269	282	292	307	314	329										
				BHP	0.24	0.25	0.26	0.27	0.29	0.30	0.31	0.33	0.34	0.35										
				Heating Rise (°F)	45	46	47	49	50	52	54	56	58	60										
				Heating Rise (°C)	25	26	26	27	28	29	30	31	32	33										
				CFM	1556	1508	1461	1432	1388	1346	1302	1256	1221	1168										
		WATTS	244	261	268	281	290	305	319	330	345	353												
		BHP	0.26	0.28	0.29	0.30	0.31	0.33	0.34	0.35	0.37	0.38												
		Heating Rise (°F)	43	44	46	47	48	50	51	53	55	57												
		Heating Rise (°C)	24	25	25	26	27	28	29	30	30	32												
		CFM	1861	1822	1786	1758	1716	1688	1660	1619	1583	1539												
		WATTS	400	417	426	441	452	467	482	492	507	519												
BHP	0.43	0.45	0.46	0.47	0.48	0.50	0.52	0.53	0.54	0.56														
Heating Rise (°F)	36	37	37	38	39	40	40	41	42	43														
Heating Rise (°C)	20	20	21	21	22	22	22	23	23	24														
CFM	2319	2291	2255	2230	2193	2166	2118	2057	1992	1887														
WATTS	758	769	787	799	808	823	822	805	780	737														
BHP	0.81	0.82	0.84	0.86	0.87	0.88	0.88	0.86	0.84	0.79														
Heating Rise (°F)	NA	NA	NA	NA	NA	NA	NA	NA	NA	NA														
Heating Rise (°C)	NA	NA	NA	NA	NA	NA	NA	NA	NA	NA														
CFM	2532	2487	2444	2391	2330	2259	2179	2111	2033	1949														
WATTS	1014	1022	1015	994	965	935	898	858	823	786														
BHP	1.09	1.10	1.09	1.07	1.03	1.00	0.96	0.92	0.88	0.84														
Heating Rise (°F)	NA	NA	NA	NA	NA	NA	NA	NA	NA	NA														
Heating Rise (°C)	NA	NA	NA	NA	NA	NA	NA	NA	NA	NA														
CFM	1503	1457	1423	1374	1330	1287	1241	1199	1153	1111														
WATTS	225	233	246	254	269	282	292	307	314	329														
BHP	0.24	0.25	0.26	0.27	0.29	0.30	0.31	0.33	0.34	0.35														
Heating Rise (°F)	57	58	60	NA	NA	NA	NA	NA	NA	NA														
Heating Rise (°C)	31	32	33	NA	NA	NA	NA	NA	NA	NA														
CFM	1556	1508	1461	1432	1388	1346	1302	1256	1221	1168														
WATTS	244	261	268	281	290	305	319	330	345	353														
BHP	0.26	0.28	0.29	0.30	0.31	0.33	0.34	0.35	0.37	0.38														
Heating Rise (°F)	55	56	58	59	NA	NA	NA	NA	NA	NA														
Heating Rise (°C)	30	31	32	33	NA	NA	NA	NA	NA	NA														
CFM	1861	1822	1786	1758	1716	1688	1660	1619	1583	1539														
WATTS	400	417	426	441	452	467	482	492	507	519														
BHP	0.43	0.45	0.46	0.47	0.48	0.50	0.52	0.53	0.54	0.56														
Heating Rise (°F)	46	47	48	48	50	50	51	53	54	55														
Heating Rise (°C)	25	26	26	27	28	28	29	29	30	31														
CFM	2319	2291	2255	2230	2193	2166	2118	2057	1992	1887														
WATTS	758	769	787	799	808	823	822	805	780	737														
BHP	0.81	0.82	0.84	0.86	0.87	0.88	0.88	0.86	0.84	0.79														
Heating Rise (°F)	37	37	38	38	39	39	40	41	43	45														
Heating Rise (°C)	20	21	21	21	22	22	22	23	24	25														
CFM	2532	2487	2444	2391	2330	2259	2179	2111	2033	1949														
WATTS	1014	1022	1015	994	965	935	898	858	823	786														
BHP	1.09	1.10	1.09	1.07	1.03	1.00	0.96	0.92	0.88	0.84														
Heating Rise (°F)	34	34	35	36	37	38	39	40	42	44														
Heating Rise (°C)	19	19	19	20	20	21	22	22	23	24														
CFM	1861	1822	1786	1758	1716	1688	1660	1619	1583	1539														
WATTS	400	417	426	441	452	467	482	492	507	519														
BHP	0.43	0.45	0.46	0.47	0.48	0.50	0.52	0.53	0.54	0.56														
Heating Rise (°F)	46	47	48	48	50	50	51	53	54	55														
Heating Rise (°C)	25	26	26	27	28	28	29	29	30	31														
CFM	2319	2291	2255	2230	2193	2166	2118	2057	1992	1887														
WATTS	758	769	787	799	808	823	822	805	780	737														
BHP	0.81	0.82	0.84	0.86	0.87	0.88	0.88	0.86	0.84	0.79														
Heating Rise (°F)	37	37	38	38	39	39	40	41	43	45														
Heating Rise (°C)	20	21	21	21	22	22	22	23	24	25														
CFM	2532	2487	2444	2391	2330	2259	2179	2111	2033	1949														
WATTS	1014	1022	1015	994	965	935	898	858	823	786														
BHP	1.09	1.10	1.09	1.07	1.03	1.00	0.96	0.92	0.88	0.84														
Heating Rise (°F)	34	34	35	36	37	38	39	40	42	44														
Heating Rise (°C)	19	19	19	20	20	21	22	22	23	24														

**Dry Coil Air Delivery – Downflow Discharge Sizes 36–60 3 Phase Models Only (Cont.)**

Unit	Heating Rise Range	Motor Speed	Wire Color	External Static Pressure (IN. W.C.)																	
				0.1	0.2	0.3	0.4	0.5	0.6	0.7	0.8	0.9	1.0								
48130	35 – 65°F (19 – 36°C)	Low	Blue	CFM	1503	1457	1423	1374	1330	1287	1241	1199	1153	1111							
				WATTS	225	233	246	254	269	282	292	307	314	329							
				BHP	0.24	0.25	0.26	0.27	0.29	0.30	0.31	0.33	0.34	0.35							
				Heating Rise (°F)	63	65	NA	NA	NA	NA	NA	NA	NA	NA							
				Heating Rise (°C)	35	36	NA	NA	NA	NA	NA	NA	NA	NA							
				CFM	1556	1508	1461	1432	1388	1346	1302	1256	1221	1168							
		Med–Low	Pink	WATTS	244	261	268	281	290	305	319	330	345	353							
				BHP	0.26	0.28	0.29	0.30	0.31	0.33	0.34	0.35	0.37	0.38							
				Heating Rise (°F)	61	63	65	NA	NA	NA	NA	NA	NA	NA							
				Heating Rise (°C)	34	35	36	NA	NA	NA	NA	NA	NA	NA							
				CFM	1861	1822	1786	1758	1716	1688	1660	1632	1604	1576							
				WATTS	400	417	426	441	452	467	482	492	507	519							
60090	35 – 65°F (19 – 36°C)	Medium <sup>2</sup>	Red	BHP	0.43	0.45	0.46	0.47	0.48	0.50	0.52	0.53	0.54	0.56							
				Heating Rise (°F)	51	52	53	54	55	56	57	59	60	62							
				Heating Rise (°C)	28	29	30	30	31	31	32	33	33	34							
				CFM	2319	2291	2255	2230	2193	2166	2118	2057	1992	1887							
				WATTS	758	769	787	799	808	823	822	805	780	737							
				BHP	0.81	0.82	0.84	0.86	0.87	0.88	0.88	0.86	0.84	0.79							
		Med–High <sup>1</sup>	Orange	Heating Rise (°F)	41	42	42	43	43	44	44	45	46	48	50						
				Heating Rise (°C)	23	23	23	24	24	24	25	26	27	28							
				CFM	2532	2487	2444	2391	2330	2259	2179	2111	2033	1949							
				WATTS	1014	1022	1015	994	965	935	898	858	823	786							
				BHP	1.09	1.10	1.09	1.07	1.03	1.00	0.96	0.92	0.88	0.84							
				Heating Rise (°F)	38	38	39	40	41	42	44	45	47	49							
60090	35 – 65°F (19 – 36°C)	Low <sup>1</sup>	Blue	Heating Rise (°C)	21	21	22	22	23	23	24	25	26	27							
				CFM	1479	1436	1387	1346	1298	1253	1206	1160	1114	1061							
				WATTS	224	239	247	262	270	284	300	307	319	330							
				BHP	0.24	0.26	0.26	0.28	0.29	0.30	0.32	0.33	0.34	0.35							
				Heating Rise (°F)	46	47	49	51	52	54	56	59	61	64							
				Heating Rise (°C)	26	26	27	28	29	30	31	33	34	36							
		Med–Low	Pink	Heating Rise (°C)	1841	1796	1761	1724	1690	1651	1616	1578	1527	1478							
				WATTS	425	434	453	460	476	485	501	508	525	542							
				BHP	0.46	0.47	0.49	0.49	0.51	0.52	0.54	0.54	0.56	0.58							
				Heating Rise (°F)	36	37	38	39	40	41	41	42	44	45							
				Heating Rise (°C)	20	21	21	22	22	23	23	24	24	25							
				CFM	1944	1913	1872	1838	1801	1771	1731	1698	1655	1613							
Medium <sup>2</sup>	Red	WATTS	486	501	511	529	537	554	565	578	595	603									
		BHP	0.52	0.54	0.55	0.57	0.58	0.59	0.61	0.62	0.64	0.65									
		Heating Rise (°F)	34	35	36	36	37	38	39	39	40	41									
		Heating Rise (°C)	19	19	20	20	21	21	21	22	22	23									
		CFM	2178	2148	2105	2073	2036	2002	1967	1919	1845	1751									
		WATTS	674	691	703	717	733	743	758	754	734	701									
Med–High	Orange	BHP	0.72	0.74	0.75	0.77	0.79	0.80	0.81	0.81	0.79	0.75									
		Heating Rise (°F)	NA	NA	NA	NA	NA	NA	NA	NA	NA	38									
		Heating Rise (°C)	NA	NA	NA	NA	NA	NA	NA	NA	NA	19									
		CFM	2480	2432	2375	2322	2236	2161	2085	2006	1917	1808									
		WATTS	1029	1012	995	975	941	908	869	836	796	751									
		BHP	1.10	1.09	1.07	1.05	1.01	0.97	0.93	0.90	0.85	0.81									
High	Black	Heating Rise (°F)	NA	NA	NA	NA	NA	NA	NA	NA	NA	35	37								
		Heating Rise (°C)	NA	NA	NA	NA	NA	NA	NA	NA	NA	19	21								

**Dry Coil Air Delivery – Downflow Discharge Sizes 36–60 3 Phase Models Only (Cont.)**

Unit	Heating Rise Range	Motor Speed	Wire Color	External Static Pressure (IN. W.C.)											
				0.1	0.2	0.3	0.4	0.5	0.6	0.7	0.8	0.9	1.0		
60115	30 – 60°F (17 – 33°C)	Low	Blue	CFM	1479	1436	1387	1346	1298	1253	1206	1160	1114	1061	
				WATTS	224	239	247	262	270	284	300	307	319	330	
				BHP	0.24	0.26	0.26	0.28	0.29	0.30	0.32	0.33	0.34	0.35	
				Heating Rise (°F)	58	59	NA	NA	NA	NA	NA	NA	NA	NA	NA
				Heating Rise (°C)	32	33	NA	NA	NA	NA	NA	NA	NA	NA	NA
				CFM	1841	1796	1761	1724	1690	1651	1616	1578	1527	1478	
		WATTS	425	434	453	460	476	485	501	508	525	542			
		BHP	0.46	0.47	0.49	0.49	0.51	0.52	0.54	0.54	0.56	0.58			
		Heating Rise (°F)	46	47	48	49	50	52	53	54	56	58			
		Heating Rise (°C)	26	26	27	27	28	29	29	30	31	32			
		CFM	1944	1913	1872	1838	1801	1771	1731	1698	1655	1613			
		WATTS	486	501	511	529	537	554	565	578	595	603			
BHP	0.52	0.54	0.55	0.57	0.58	0.59	0.61	0.62	0.64	0.65					
Heating Rise (°F)	44	45	46	46	47	48	49	50	51	53					
Heating Rise (°C)	24	25	25	26	26	27	27	28	29	29					
CFM	2178	2148	2105	2073	2036	2002	1967	1919	1845	1751					
WATTS	674	691	703	717	733	743	758	754	734	701					
BHP	0.72	0.74	0.75	0.77	0.79	0.80	0.81	0.81	0.79	0.75					
Heating Rise (°F)	39	40	40	41	42	43	43	44	46	49					
Heating Rise (°C)	22	22	22	23	23	24	24	25	26	27					
CFM	2480	2432	2375	2322	2236	2161	2085	2006	1917	1808					
WATTS	1029	1012	995	975	941	908	869	836	796	751					
BHP	1.10	1.09	1.07	1.05	1.01	0.97	0.93	0.90	0.85	0.81					
Heating Rise (°F)	NA	35	36	37	38	39	41	42	44	47					
Heating Rise (°C)	NA	19	20	20	21	22	23	24	25	26					
CFM	1479	1436	1387	1346	1298	1253	1206	1160	1114	1061					
WATTS	224	239	247	262	270	284	300	307	319	330					
BHP	0.24	0.26	0.26	0.28	0.29	0.30	0.32	0.33	0.34	0.35					
Heating Rise (°F)	64	NA	NA	NA	NA	NA	NA	NA	NA	NA					
Heating Rise (°C)	36	NA	NA	NA	NA	NA	NA	NA	NA	NA					
CFM	1841	1796	1761	1724	1690	1651	1616	1578	1527	1478					
WATTS	425	434	453	460	476	485	501	508	525	542					
BHP	0.46	0.47	0.49	0.49	0.51	0.52	0.54	0.54	0.56	0.58					
Heating Rise (°F)	52	53	54	55	56	58	59	60	62	64					
Heating Rise (°C)	29	29	30	31	31	32	33	34	35	36					
CFM	1944	1913	1872	1838	1801	1771	1731	1698	1655	1613					
WATTS	486	501	511	529	537	554	565	578	595	603					
BHP	0.52	0.54	0.55	0.57	0.58	0.59	0.61	0.62	0.64	0.65					
Heating Rise (°F)	49	50	51	52	53	54	55	56	58	59					
Heating Rise (°C)	27	28	28	29	29	30	31	31	32	33					
CFM	2178	2148	2105	2073	2036	2002	1967	1919	1845	1751					
WATTS	674	691	703	717	733	743	758	754	734	701					
BHP	0.72	0.74	0.75	0.77	0.79	0.80	0.81	0.81	0.79	0.75					
Heating Rise (°F)	44	44	45	46	47	48	48	50	52	54					
Heating Rise (°C)	24	25	25	26	26	26	27	28	29	30					
CFM	2480	2432	2375	2322	2236	2161	2085	2006	1917	1808					
WATTS	1029	1012	995	975	941	908	869	836	796	751					
BHP	1.10	1.09	1.07	1.05	1.01	0.97	0.93	0.90	0.85	0.81					
Heating Rise (°F)	38	39	40	41	43	44	46	47	50	53					
Heating Rise (°C)	21	22	22	23	24	24	25	26	28	29					

\*Air delivery values are without air filter and are for dry coil (See Wet Coil Pressure Drop table).

<sup>1</sup> Factory-shipped heating speed

<sup>2</sup> Factory-shipped cooling speed

"NA" = Not allowed for heating speed

**NOTE:** Ductwork field-supplied air filter pressure drop and wet coil pressure drop to obtain external static pressure available for ducting.

Shaded areas indicate speed/static combinations that are not permitted for dehumidification speed.

**Wet Coil Pressure Drop (IN. W.C.)**

UNIT SIZE	STANDARD CFM (SCFM)																
	600	700	800	900	1000	1100	1200	1300	1400	1500	1600	1700	1800	1900	2000	2100	2200
24	0.03	0.04	0.04	0.05	0.06												
30				0.05	0.06	0.07	0.08	0.11									
36				0.06	0.06	0.09	0.10	0.11	0.14								
42					0.05	0.05	0.06	0.07	0.08	0.08	0.09	0.09	0.11				
48							0.04	0.06	0.09	0.10	0.10	0.11	0.12	0.13	0.14		
60									0.06	0.07	0.07	0.08	0.09	0.10	0.10	0.12	0.13

**Economizer with 1-in. Filter Pressure Drop (IN. W.C.)**

FILTER SIZE IN. (MM)	COOLING TONS	STANDARD CFM (SCFM)																
		600	700	800	900	1000	1100	1200	1300	1400	1500	1600	1700	1800	1900	2000	2100	2200
600-1400 CFM 12x20x1 + 12x20x1 (305x508x25+305x508x25)	2.0,	-	-	0.09	0.14	0.16	0.18	0.25	0.28	0.30	-	-	-	-	-	-	-	-
	2.5,																	
	3.0																	
1200-1800 CFM 16x24x1 + 14x24x1 (406x610x25+356x610x25)	3.5,	-	-	-	-	-	-	0.10	0.11	0.12	0.13	0.14	0.16	0.16	-	-	-	-
	4.0																	
1500-2200 CFM 16x24x1 + 18x24x1 (406x610x25+457x610x25)	5.0	-	-	-	-	-	-	-	-	-	0.15	0.17	0.18	0.20	0.21	0.22	0.23	0.23

**Filter Pressure Drop Table (IN. W.C.)**

FILTER SIZE IN. (MM)	COOLING TONS	STANDARD CFM (SCFM)																
		600	700	800	900	1000	1100	1200	1300	1400	1500	1600	1700	1800	1900	2000	2100	2200
600-1400 CFM 12x20x1 + 12x20x1 (305x508x25+305x508x25)	2.0,	0.03	0.05	0.06	0.08	0.10	0.11	0.13	0.14	0.16	-	-	-	-	-	-	-	-
	2.5,																	
	3.0																	
1200-1800 CFM 16x24x1 + 14x24x1 (406x610x25+356x610x25)	3.5,	-	-	-	-	-	-	0.07	0.08	0.09	0.10	0.11	0.12	-	-	-	-	-
	4.0																	
1500-2200 CFM 16x24x1 + 18x24x1 (406x610x25+457x610x25)	5.0	-	-	-	-	-	-	-	-	-	0.04	0.06	0.08	0.10	0.11	0.13	0.14	0.15

# TYPICAL PIPING AND WIRING

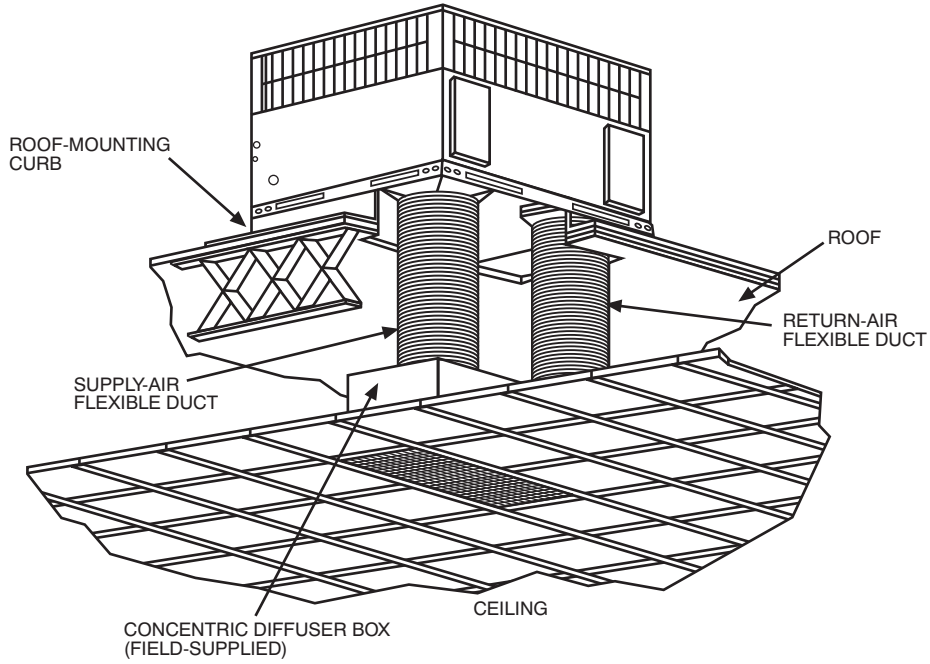

A09230

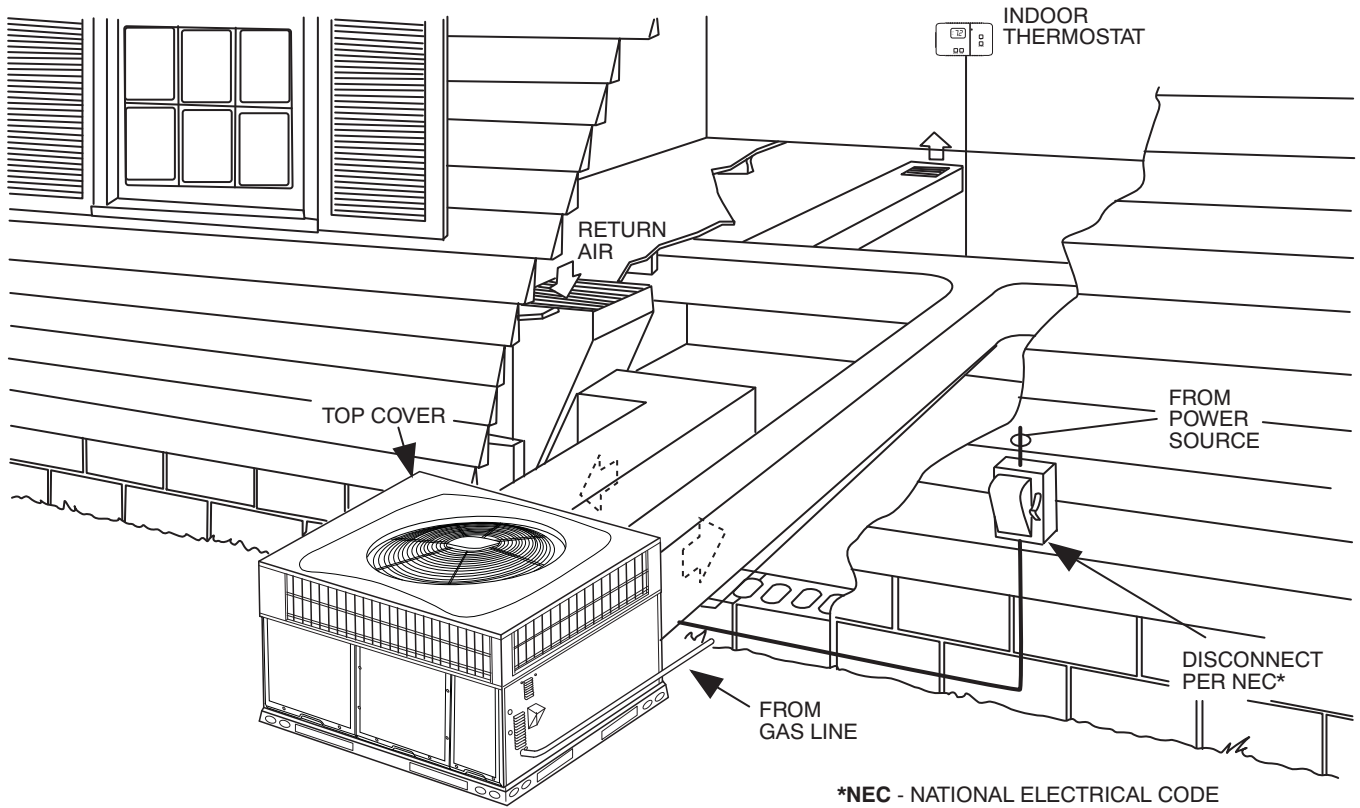

A09231

## APPLICATION DATA

**Condensate trap** — A 2-in. (50.8 mm) condensate trap must be field supplied.

**Ductwork** — Secure downflow discharge ductwork to roof curb. For horizontal discharge applications, attach ductwork to unit with flanges.

**To convert a unit to downflow discharge** — Units are equipped with factory-installed inserts in the down-flow openings. Removal of the inserts is similar to removing an electrical knock-out. Use the duct cover to seal the horizontal discharge openings in the unit. Units installed in horizontal discharge orientation do not require duct covers.

**Airflow** — Units are draw-thru in the cooling mode and blow-thru in the heating mode.

**Maximum cooling airflow** — To minimize the possibility of condensate blow-off from the evaporator, airflow through the units should not exceed 450 cfm per ton.

**Minimum cooling airflow** — Minimum cooling airflow is 350 cfm per ton.

**Minimum ambient cooling operation temperature** — All standard units have a minimum ambient operating temperature of 40°F (4°C). With accessory low ambient temperature kit, units can operate at temperatures down to 0°F (-17°C).

**Minimum temperature** — Air entering the heat exchanger in heating mode must be a minimum of 50°F (10°C) continuous and/or 45°F (7°C) intermittent.

## 1ELECTRICAL DATA

MODEL	NOMINAL V-PH-HZ	VOLTAGE RANGE		COMPRESSOR		OFM	IFM	IDM	POWER SUPPLY	
		MIN	MAX	RLA	LRA	FLA	FLA	FLA	MCA	MOCP
24040	208/230-1-60	197	253	8.7	46	0.6	3.8	0.65	15.2	20
24060	208/230-1-60	197	253	8.7	46	0.6	3.8	0.65	15.2	20
30040	208/230-1-60	197	253	11.2	57	0.7	3.8	0.65	18.5	25
30060	208/230-1-60	197	253	11.2	57	0.7	3.8	0.65	18.5	25
36060	208/230-1-60	197	253	16.7	79	1.05	5.4	0.65	27.4	40
36060	208/230-3-60	197	253	10.4	73	1.05	6	1.65	20.1	30
36060	460-3-60	414	506	5.8	38	0.53	3.2	0.65	11.0	15
36090	208/230-1-60	197	253	16.7	79	1.05	5.4	.75	27.4	40
36090	208/230-3-60	197	253	10.4	73	1.05	6	0.52	20.1	30
36090	460-3-60	414	506	5.8	38	0.53	3.2	0.3	11.0	15
42060	208/230-1-60	197	253	16.7	109	1.05	3.8	0.65	25.8	40
42060	208/230-3-60	197	253	11.2	88	1.05	4.1	1.65	19.2	30
42060	460-3-60	414	506	5.6	44	0.53	3.2	0.65	10.7	15
42090	208/230-1-60	197	253	16.7	109	1.05	3.8	0.65	25.8	40
42090	208/230-3-60	197	253	11.2	88	1.05	4.1	0.65	19.2	30
42090	460-3-60	414	506	5.6	44	0.53	3.2	0.33	10.7	15
48090	208/230-1-60	197	253	19.6	130	1.05	7.6	0.65	33.2	50
48090	208/230-3-60	197	253	13.7	83.1	1.05	7.6	0.65	25.8	35
48090	460-3-60	414	506	6.2	41	0.53	4.0	0.33	12.3	15
48115	208/230-1-60	197	253	19.6	130	1.05	7.6	0.65	33.2	50
48115	208/230-3-60	197	253	13.7	83.1	1.05	7.6	1.65	25.8	35
48115	460-3-60	414	506	6.2	41	0.53	4.0	0.65	12.3	15
48130	208/230-1-60	197	253	19.6	130	1.05	7.6	.75	33.2	50
48130	208/230-3-60	197	253	13.7	83.1	1.05	7.6	0.52	25.8	35
48130	460-3-60	414	506	6.2	41	0.53	4.0	0.3	12.3	15
60090	208/230-1-60	197	253	23.7	152.5	1.05	7.6	0.65	38.3	60
60090	208/230-3-60	197	253	15.9	110	1.05	7.6	0.65	28.6	40
60090	460-3-60	414	506	7.1	52	0.53	4.0	0.33	13.4	20
60115	208/230-1-60	197	253	23.7	152.5	1.05	7.6	0.65	38.3	60
60115	208/230-3-60	197	253	15.9	110	1.05	7.6	1.65	28.6	40
60115	460-3-60	414	506	7.1	52	0.53	4.0	0.65	13.4	20
60130	208/230-1-60	197	253	23.7	152.5	1.05	7.6	.75	38.3	60
60130	208/230-3-60	197	253	15.9	110	1.05	7.6	0.52	28.6	40
60130	460-3-60	414	506	7.1	52	0.53	4.0	0.3	13.4	20

LEGEND

- FLA - Full Load Amps
- IDM - Inducer Motor
- IFM - Indoor Fan Motor
- LRA - Locked Rotor Amps
- MCA - Minimum Circuit Amps
- MOCP - Maximum Over Current Protection
- OFM - Outdoor Fan Motor
- RLA - Rated Load Amps

NOTES:

1. In compliance with NEC (National Electrical Code) requirements for multimotor and combination load equipment (refer to NEC Articles 430 and 440), the overcurrent protective device for the unit shall be Power Supply fuse or circuit breaker.
2. Minimum wire size is based on 60 C copper wire. If other than 60 C wire is used, or if length exceeds wire length in table, determine size from NEC.
3. Unbalanced 3-Phase Supply Voltage  
*Never operate a motor where a phase imbalance in supply voltage is greater than 2%.* Use the following formula to determine the percentage of voltage imbalance

% Voltage imbalance

$$= 100 \times \frac{\text{max voltage deviation from average voltage}}{\text{average voltage}}$$

EXAMPLE: Supply voltage is 230-3-60.

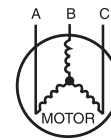

- AB = 228 v
- BC = 231 v
- AC = 227 v

$$\begin{aligned} \text{Average Voltage} &= \frac{228 + 231 + 227}{3} \\ &= \frac{686}{3} \\ &= 229 \end{aligned}$$

Determine maximum deviation from average voltage.

- (AB) 229 - 228 = 1 v
- (BC) 231 - 229 = 2 v
- (AC) 229 - 227 = 2 v

Maximum deviation is 2 v.

Determine percent of voltage imbalance

$$\begin{aligned} \% \text{ Voltage Imbalance} &= 100 \times \frac{2}{229} \\ &= 0.8\% \end{aligned}$$

This amount of phase imbalance is satisfactory as it is below the maximum allowable 2%.

**IMPORTANT:** If the supply voltage phase imbalance is more than 2%, contact your local electric utility company immediately.

A06564



# LADDER WIRING SCHEMATIC 208/230-1-60

## LADDER WIRING DIAGRAM

**DANGER: ELECTRICAL SHOCK HAZARD DISCONNECT POWER BEFORE SERVICING**

LEGEND		
	FIELD SPICE	EQUIP
	TERMINAL (MARKED)	FS
	TERMINAL (UNMARKED)	GND
	SPLICE	HPS
	SPLICE (MARKED)	I
	FACTORY LO VOLTAGE	IDM
	FIELD CONTROL WIRING	IFM
	FIELD POWER WIRING	IGC
	ACCESSORY OR OPTIONAL WIRING	LGPS
	FACTORY HI VOLTAGE	LPS
	CONTACTOR	LS1
	CAPACITOR, COMP	LS2
	CAPACITOR, INDUCER (WHEN USED)	MGV
	CRANKCASE HEATER	OT
	CRANKCASE HEATER SWITCH	RS
	COMPRESSOR MOTOR	TRAN
		T-STAT
		EQUIPMENT
		FLAME SENSOR
		GROUND
		HIGH PRESSURE SWITCH
		IGNITOR
		INDUCED DRAFT MOTOR
		INDOOR FAN MOTOR
		INTERGRATED GAS UNIT CONTROLLER
		LOW GAS PRESSURE SWITCH (WHEN USED)
		LOW PRESSURE SWITCH
		PRIMARY LIMIT SWITCH
		SECONDARY LIMIT SWITCH
		MAIN GAS VALVE
		OUTDOOR FAN MOTOR
		QUADRUPLE TERMINAL
		ROLLOUT SWITCH
		TRANSFORMER
		THERMOSTAT

### 10 UNIT COMPONENT ARRANGEMENT

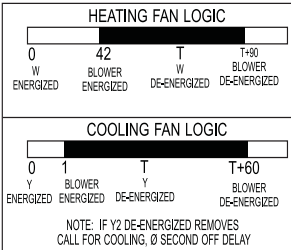
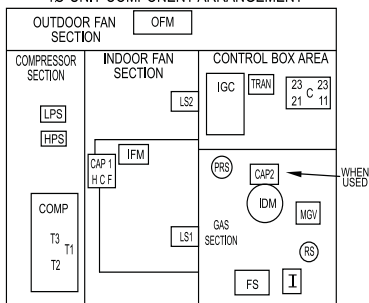

### NOTES:

- IF ANY OF THE ORIGINAL WIRES FURNISHED ARE REPLACED THEY MUST BE REPLACED WITH THE SAME WIRE OR IT'S EQUIVALENT.
- SEE PRE-SALE LITERATURE FOR THERMOSTATS.
- USE 75 DEGREES C COPPER CONDUCTORS FOR FIELD INSTALLATION.
- REFER TO INSTALLATION INSTRUCTIONS FOR CORRECT SPEED SELECTION FOR IFM.
- SEE INSTALLATION INSTRUCTIONS FOR PROPER HEATING AND COOLING CONNECTIONS FOR YOUR UNIT.
- ON SOME MODELS LS1 AND LS2 ARE WIRED IN SERIES. ON OTHER MODELS ONLY LS1 IS USED.
- THIS FUSE IS MANUFACTURED BY LITTLE FUSE, PIN 287003.
- DO NOT DISCONNECT PLUG UNDER LOAD.
- N.E.C. CLASS 2, 24V.

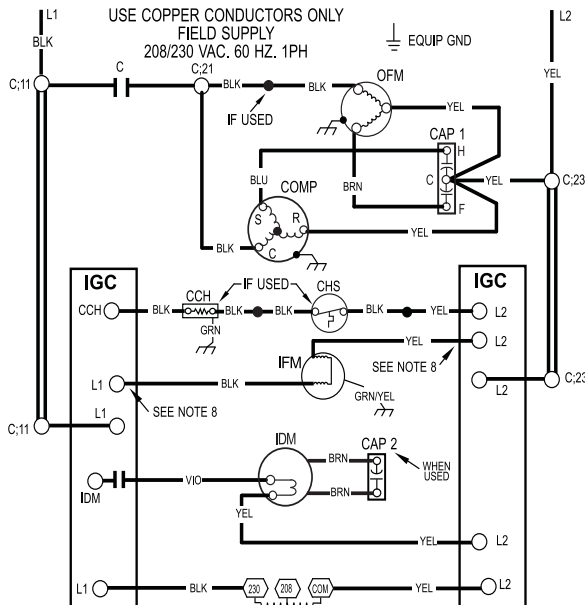

### T-STAT

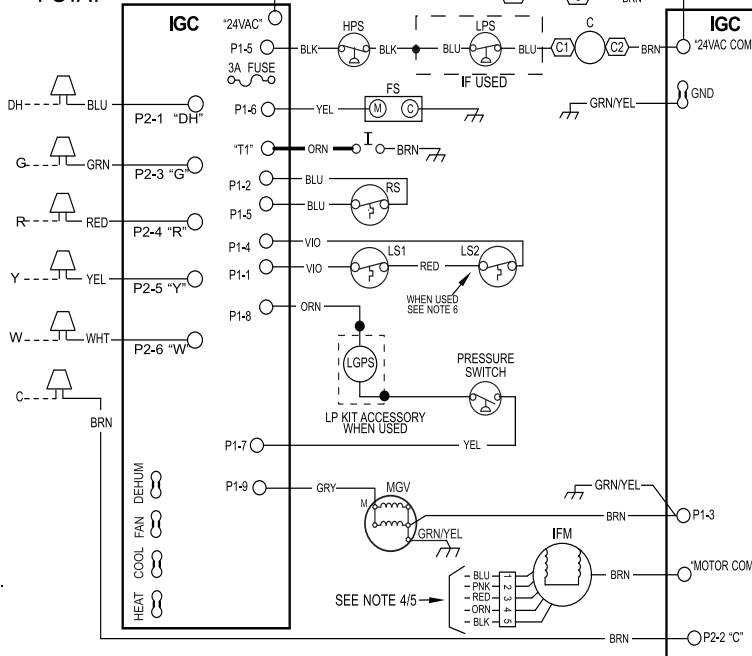

48VLS00420 REV. 1

48VLS00420 REV. 1



A150510

CONNECTION WIRING DIAGRAM

DANGER: ELECTRICAL SHOCK HAZARD DISCONNECT POWER BEFORE SERVICING

NOTES:

1. IF ANY OF THE ORIGINAL WIRES FURNISHED ARE REPLACED, THEY MUST BE REPLACED WITH TYPE 90 DEG. C WIRE OR ITS EQUIVALENT.
2. SEE PRE-SALE LITERATURE FOR THERMOSTAT AND SUBBASES. - "DO NOT DISCONNECT UNDER LOAD"
3. USE MIN. 75 DEG. COPPER CONDUCTORS FOR FIELD INSTALLATION.
4. SEE INSTALLATION INSTRUCTIONS FOR PROPER HEATING AND COOLING CONNECTIONS FOR YOUR UNIT. INDOOR FAN MOTOR PLUGS - "DO NOT DISCONNECT UNDER LOAD"
5. LS2 USED ON SMALL CHASSIS ONLY. IF CAP2 IS PRESENT, YELLOW WIRES FROM IGC AND IDM CONNECT ON SAME SIDE OF CAP2.
7. THIS FUSE IS MANUFACTURED BY LITTELFUSE, P/N 287003.
8. THIS FUSE IS MANUFACTURED BY LITTELFUSE, P/N 287005.
9. DEHUMIDIFICATION FEATURE CANNOT BE USED WHEN ECONOMIZER IS INSTALLED.
10. N.E.C. CLASS 2 24 V

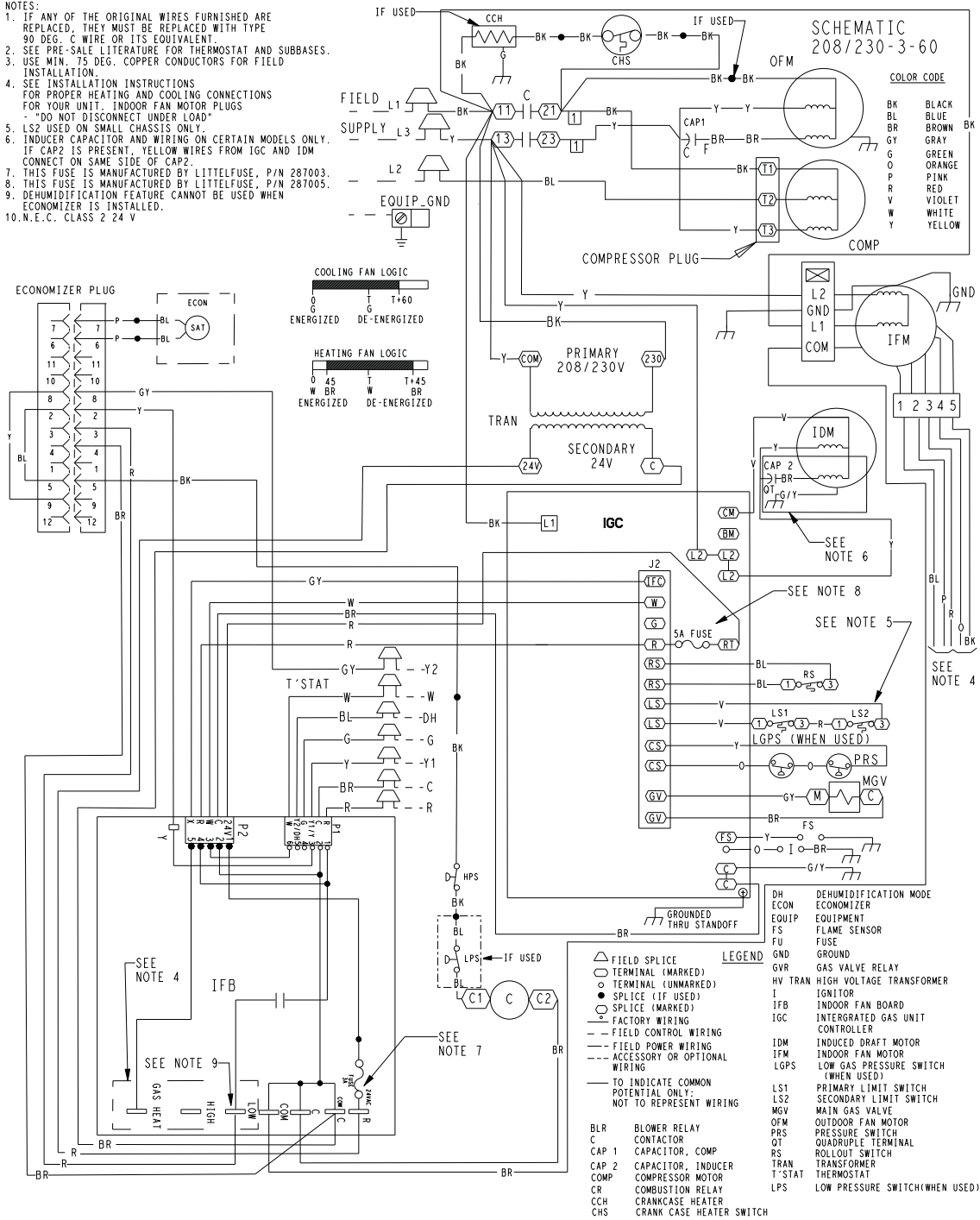

LADDER WIRING DIAGRAM

DANGER: ELECTRICAL SHOCK HAZARD DISCONNECT POWER BEFORE SERVICING

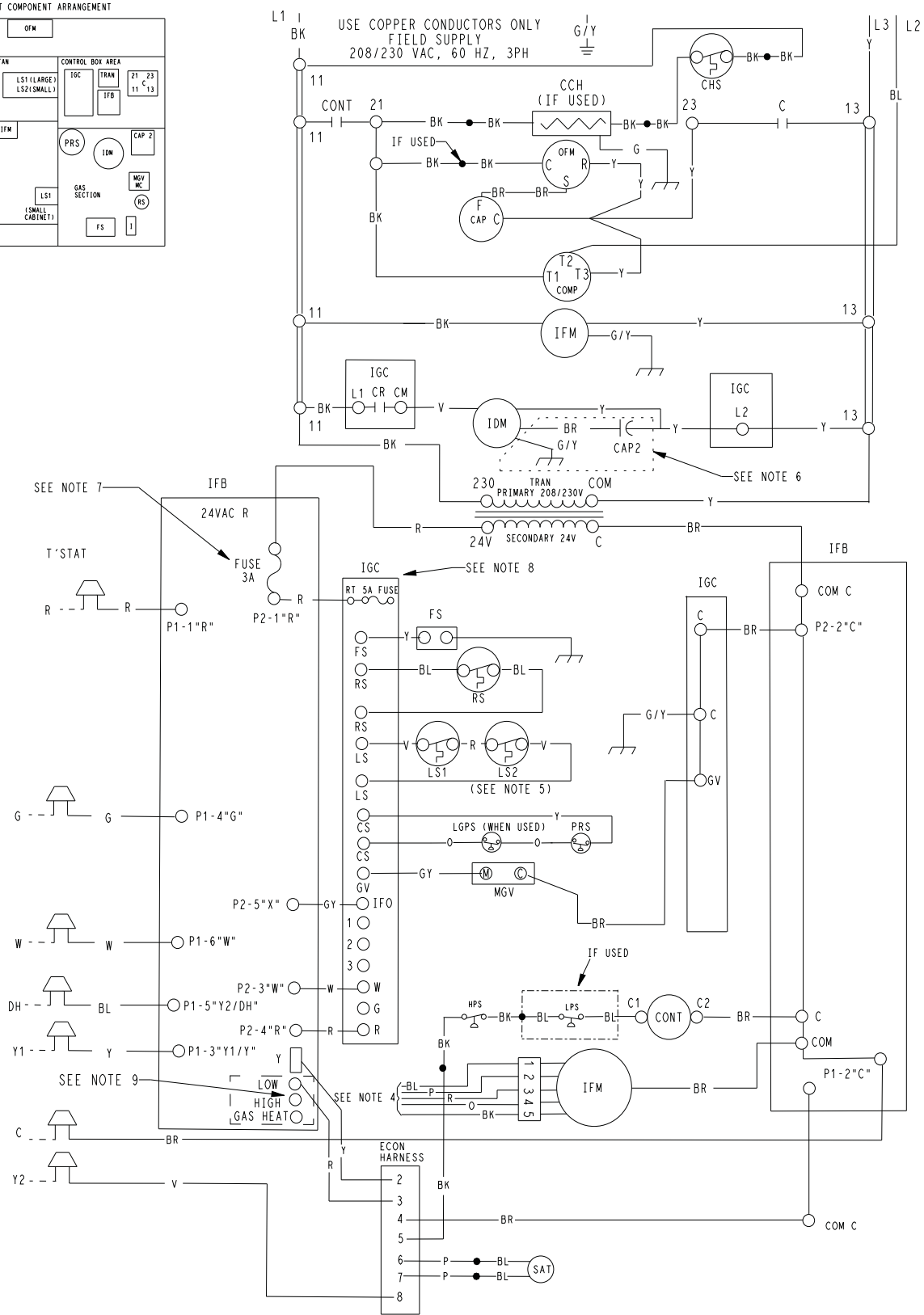
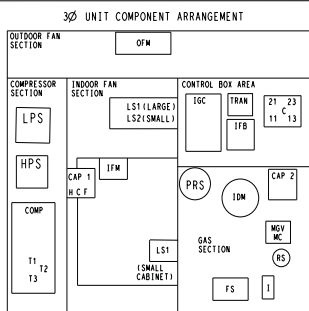

48VL500421 -

A150511

CONNECTION WIRING DIAGRAM

DANGER: ELECTRICAL SHOCK HAZARD DISCONNECT POWER BEFORE SERVICING

NOTES:

1. IF ANY OF THE ORIGINAL WIRES FURNISHED ARE REPLACED, THEY MUST BE REPLACED WITH TYPE 90 DEG. C WIRE OR ITS EQUIVALENT.
2. SEE PRE-SALE LITERATURE FOR THERMOSTAT AND SUBBASES.
3. USE MIN. 75 DEG. COPPER CONDUCTORS FOR FIELD INSTALLATION.
4. SEE INSTALLATION INSTRUCTIONS FOR PROPER HEATING AND COOLING CONNECTIONS FOR YOUR UNIT. INDOOR FAN MOTOR PLUGS -- "DO NOT DISCONNECT UNDER LOAD"
5. LS2 USED ON SMALL CHASSIS ONLY.
6. INDUCER CAPACITOR AND WIRING ON CERTAIN MODELS ONLY. IF CAP2 IS PRESENT, YELLOW WIRES FROM CONTACTOR AND IDM CONNECT ON SAME SIDE OF CAP2.
7. THIS FUSE IS MANUFACTURED BY LITTELFUSE, P/N 287003.
8. THIS FUSE IS MANUFACTURED BY LITTELFUSE, P/N 287005.
9. DEHUMIDIFICATION FEATURE CANNOT BE USED WHEN ECONOMIZER IS INSTALLED.
10. N.E.C. CLASS 2 24 V

SCHEMATIC 460-3-60

COLOR CODE

BK	BLACK
BL	BLUE
BR	BROWN
GY	GRAY
G	GREEN
O	ORANGE
P	PINK
R	RED
V	VIOLET
W	WHITE
Y	YELLOW

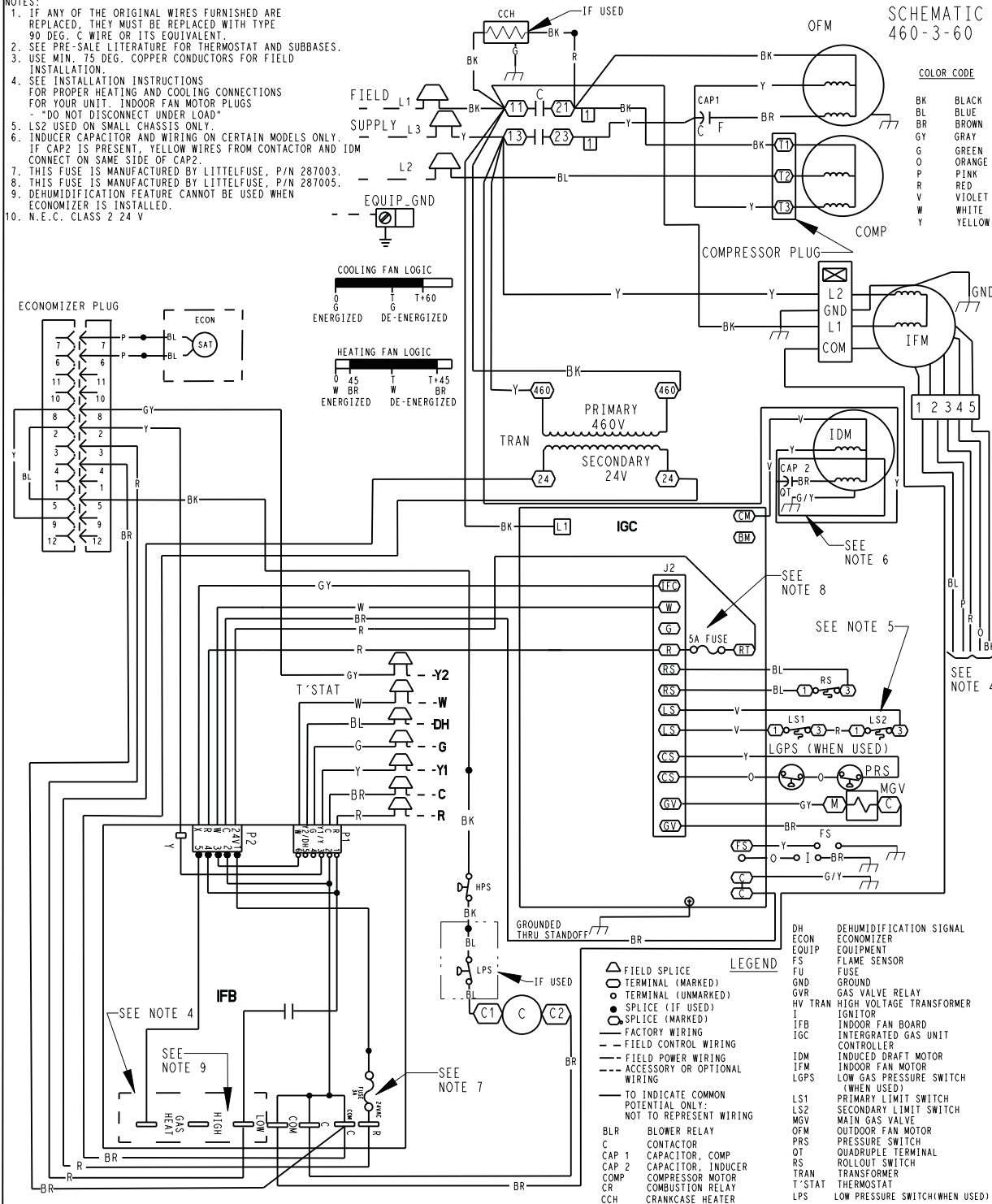

A150509

# LADDER WIRING SCHEMATIC 460-3-60

## LADDER WIRING DIAGRAM

**DANGER: ELECTRICAL SHOCK HAZARD DISCONNECT POWER BEFORE SERVICING**

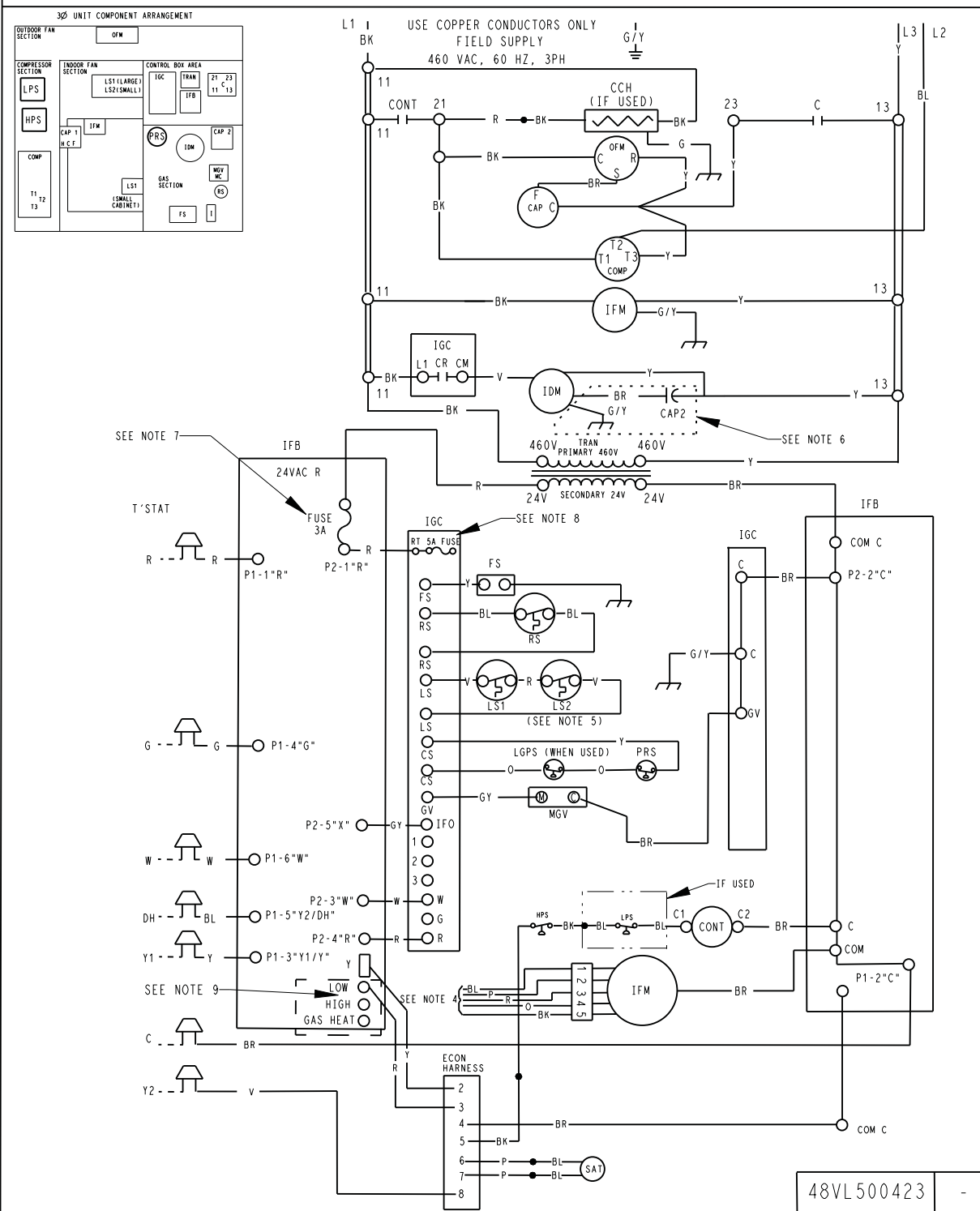

A150512

## CONTROLS

### Operating sequence

**Heating (Single Phase Models)** – (See unit wiring label) On a call for heating, terminal W of the thermostat is energized, starting the induced-draft motor for a 5 second pre-purge. When the pressure switch senses that the induced-draft motor is moving sufficient combustion air, the burner sequence begins. This function is controlled by the integrated gas unit controller (IGC). The indoor (evaporator) fan motor is energized 30 seconds after flame is established. When the thermostat is satisfied and W is de-energized, the burners stop firing and the indoor (evaporator) fan motor shuts off after a 90 second time-off delay. Please note that the IGC has the capability to automatically reduce the indoor fan motor on delay and increase the indoor fan motor off delay in the event of high duct static and/or a partially-clogged filter.

**Heating (Three Phase Models)** – On a call for heating, terminal W of the thermostat is energized, starting the induced-draft motor. When the pressure switch senses that the induced-draft motor is moving sufficient combustion air, the burner sequence begins. This function is performed by the integrated gas unit controller (IGC). The indoor (evaporator) fan motor is energized 45 sec after flame is established. When the thermostat is satisfied and W is de-energized, the burners stop firing and the indoor (evaporator) fan motor shuts off after a 45-sec time-off delay. Please note that the IGC has the capability to automatically reduce the indoor fan motor on delay and increase the indoor fan motor off delay in the event of high duct static and/or partially-clogged filter.

**Cooling** — When the system thermostat calls for cooling, 24 V is supplied to the “Y” and “G” terminals of the thermostat. This completes the circuit to the contactor coil (C) and indoor (evaporator) fan relay (IFR). The normally open contacts of energized C close and complete the circuit through compressor motor (COMP) to outdoor (condenser) fan motor (OFM). Both motors start instantly. The set of normally open contacts of energized IFR close and complete the circuit through IFM. The IFM starts instantly.

On the loss of the thermostat call for cooling, 24 V is removed from both the “Y” and “G” terminals (provided the fan switch is in the “AUTO” position) de-energizing the compressor contactor and opening the contacts supplying power to compressor/OFM. After a 60-second delay (1-phase) or 90-second delay (3-phase), the IFM shuts off. If the thermostat fan selector switch is in the “ON” position, the IFM will run continuously.

## GUIDE SPECIFICATIONS

### Packaged Gas Heating/Electric Cooling Units Constant Volume Application

#### HVAC Guide Specifications

Size Range: **2 to 5 Tons, Nominal Cooling  
40,000 to 127,000 Btuh,  
Nominal Heating Input**

#### SYSTEM DESCRIPTION

Outdoor rooftop mounted, gas heating/electric cooling unit utilizing a hermetic scroll compressor for cooling duty. Unit shall discharge supply air vertically or horizontally as shown on contract drawings. Condenser fan/coil section shall have a draw-thru design with vertical discharge for minimum sound levels.

#### QUALITY ASSURANCE

- A. Unit shall be rated in accordance with AHRI Standards 210/240 and 270-1995.**
- B. Unit shall be designed in accordance with UL Standard 1995 and ANSI Z 21.47.**
- C. Unit shall be manufactured in a facility registered to ISO 9001 manufacturing quality standard.**
- D. Unit shall be UL listed and c-UL certified as a total package for safety requirements.**
- E. Roof curb shall be designed to conform to NRCA Standards.**
- F. Insulation and adhesives shall meet NFPA 90.1 requirements for flame spread and smoke generation.**
- G. Cabinet insulation shall meet ASHRAE Standard 62.2.**

#### DELIVERY, STORAGE AND HANDLING

Unit shall be stored and handled per manufacturer's recommendations.

#### Part 2 — Products

##### EQUIPMENT

###### A. General:

Factory-assembled, single-piece, heating and cooling unit. Contained within the enclosure shall be all factory wiring, piping, controls, refrigerant charge with R-410A refrigerant, and special features required prior to field start-up.

###### B. Unit Cabinet:

1. Unit cabinet shall be constructed of phosphated, zinc-coated, pre-painted steel capable of with-standing 500 hours in salt spray.
2. Normal service shall be through 3 removable cabinet panels.
3. The unit shall be constructed on a rust proof unit base that has an externally trapped, integrated sloped drain.
4. Evaporator fan compartment top surface shall be insulated with a minimum 1/2-in. (12.7 mm) thick, flexible fiberglass insulation, coated on the air side and retained by adhesive and mechanical means. The evaporator wall sections will be insulated with a minimum semi-rigid foil-faced board capable of being wiped clean. Aluminum foil-faced fiberglass insulation shall be used in the entire indoor air cavity section.
5. Unit shall have a field-supplied condensate trap.

###### C. Fans:

1. The evaporator fan shall be a multi-speed, direct-drive, as shown on equipment drawings.
2. Fan wheel shall be made from steel, be double-inlet type with forward curved blades with corrosion resistant finish. Fan wheel shall be dynamically balanced.
3. Condenser fan shall be direct drive propeller type with aluminum blades riveted to corrosion resistant steel spiders, be dynamically balanced, and discharge air vertically.

###### D. Compressor:

1. Fully hermetic compressors with factory-installed vibration isolation.

###### E. Coils:

Evaporator and condenser coils shall have aluminum plate fins mechanically bonded to seamless copper tubes with all joints brazed. Tube sheet openings shall be belled to prevent tube wear.

## GUIDE SPECIFICATIONS (CONT)

### F. Heating Section:

1. Induced-draft combustion type with energy saving direct spark ignition system and redundant main gas valve.
2. Induced-draft motors shall provide adequate airflow for combustion.
3. The heat exchangers shall be constructed of aluminized steel for corrosion resistance.
4. Burners shall be of the in-shot type constructed of aluminum coated steel.
5. All gas piping and electric power shall enter the unit cabinet at a single location.

### G. Refrigerant Components:

Refrigerant expansion device shall be of the TXV (thermostatic expansion valve) or fixed orifice type.

### H. Filters:

Filter section shall consist of field-installed, throwaway, 1-in. (25 mm) thick fiberglass filters of commercially available sizes.

### I. Controls and Safeties:

1. Unit controls shall be complete with a self-contained low voltage control circuit.
2. Compressors shall incorporate a solid-state compressor protector that provides reset capability.

### J. Operating Characteristics:

1. Unit shall be capable of starting and running at 125°F (51°C) ambient outdoor temperature per maximum load criteria of AHRI Standard 210.
2. Compressor with standard controls shall be capable of operation down to 40°F (4°C) ambient outdoor temperature.
3. Units shall be provided with fan time delay to prevent cold air delivery before the heat exchanger warms up.
4. Unit shall be provided with 60-second fan time delay (single phase models) or 90 second fan time delay (three phase models) after the thermostat is satisfied.

### K. Electrical Requirements:

All unit power wiring shall enter the unit cabinet at a single location.

### L. Motors:

1. Compressor motors shall be of the refrigerant-cooled type with line-break thermal and current overload protection.
2. All fan motors shall have permanently lubricated bearings, and inherent, automatic reset, thermal overload protection.
3. Condenser fan motor shall be totally enclosed.
4. Evaporator Fan Motor to be ECM Motor.

### M. Compressor Protection:

**Solid-state control shall protect compressor by preventing "short cycling."**

### N. Low NOx:

**Shall provide NOx reduction to values below 40 nano-grams/joule to meet California's and other localities' emission requirements as shipped from factory.**

### O. Special Features Available:

1. Compressor Start Kit (single phase units only):  
Shall provide additional starting torque for single-phase compressors.
2. Thermostat:  
To provide for one-stage heating and cooling in addition manual or automatic changeover and indoor fan control.

3. Crankcase Heater:  
Shall provide anti-floodback protection for low-load cooling applications.
4. Economizer:  
(Horizontal – Field installed accessory)  
(Vertical – Field installed accessory)
  - a. Economizer controls capable of providing free cooling using outside air.
  - b. Equipped with low leakage dampers not to exceed 3% leakage, at 1.0 IN. W.C. pressure differential.
  - c. Spring return motor shuts off outdoor damper on power failure.
5. Filter Rack Kit:  
Shall provide filter mounting for downflow applications. Offered as field installed accessory.
6. Flat Roof Curb:  
Curbs shall have seal strip and a wood nailer for flashing and shall be installed per manufacturer's instructions.
7. Flue Discharge Deflector  
Directs flue gas exhaust; 90 degrees upward from current discharge.
8. High Altitude Propane Conversion Kit:  
Shall consist of all required hardware to convert to propane gas heat operation at 2001 to 6000 ft (611 to 1829 m) above sea level.
9. Low Ambient Package:  
Shall consist of a solid-state control and condenser coil temperature sensor for controlling condenser-fan motor operation, which shall allow unit to operate down to 0°F (-18°C) outdoor ambient temperature when properly installed.
10. Manual Outdoor Air Damper:  
Package shall consist of damper, birdscreen, and rain-hood which can be preset to admit outdoor air for year-round ventilation.
11. Natural-to-Propane Conversion Kit:  
Shall be complete with all required hardware to convert to propane gas operation at 10.0 IN. W.C. manifold pressure.
12. Propane-to-Natural Conversion Kit  
Shall be complete with all hardware to convert to natural gas at standard altitude (0 to 2000 ft [0 to 610 m] above sea level).
13. Square-To-Round Duct Transitions (24-48 models):  
Shall have the ability to convert the supply and return openings from rectangular to round.
14. Low Pressure Switch Kit  
Kit is designed for use when a low pressure control is desired. This kit provides added reliability for the compressor.

## ACCESSORIES

PGD4, PGS4 ACCESSORIES		
Accessory Model Number	Description	Use With
<b>CURBS</b>		
CPRFCURB011A00	Roof Curb, 14" High	24 – 60
CPRFCURB013A00	Roof Curb, 14" High	42 – 60
<b>Note: CPRFCURB011A00 can be used with 42–60 size units with some overhang.</b>		
<b>ADAPTER CURBS*</b>		
CPADCURB001A00	Adapter curb for use with NPRFCURB006A00 & NPRFCURB007A00	24 – 36
CPADCURB002A00	Adapter curb for use with NPRFCURB008A00 & NPRFCURB009A00	42 – 60
* Can also be used when replacing other manufacturer's older generation units that contain a composite base without a metal base rail.		
<b>CONCENTRIC ADAPTERS – (Use with curb only)</b>		
NPCONADP001A00	For 18" round duct (use with curb CPRFCURB011A00)	Small Curb
NPCONADP002A00	For 18" round duct (use with curb CPRFCURB013A00)	Large Curb
<b>ECONOMIZERS</b>		
CPECOMZR007B00	Dedicated Vertical Economizer – Internal with solid state controller, gear driven, fully modulating damper, spring return actuator, up to 50% barometric relief, supply and dry bulb outdoor air sensors. Includes filter rack with 1" filters.	24 – 36
CPECOMZR008A00		42 – 48
CPECOMZR009A00		60
CPECOMZR010A00	Dedicated Horizontal Economizer – Internal with solid state controller, fully modulating damper, spring return actuator, supply and dry bulb outdoor air sensor, and low ambient compressor lockout switch included. Includes filter rack with 1" filters.	24 – 36
CPECOMZR011A00		42 – 48
CPECOMZR012A00		60
AXB078ENT	Outdoor Enthalpy Control	ALL
* Outdoor enthalpy available as field installed accessory; Filter rack and 1" filter, same as CPFILTRK kit		
<b>DAMPERS</b>		
CPMANDPR007A00	Manual Outside Air Damper (Includes filter rack and 1" filter, same as CPFILTRK kit)	24 – 36
CPMANDPR008A00		42 – 48
CPMANDPR009A00		60
<b>INTERNAL FILTER RACKS</b>		
CPFILTRK007A00	Internal Filter Rack (includes 1-inch filters)	24 – 36
CPFILTRK008A00		42– 48
CPFILTRK009A00		60
<b>CRANKCASE HEATER – BELLY BAND TYPE</b>		
CPCRKHTR008A00	240V Crankcase Heater (3-phase)	24 – 36
CPCRKHTR004A00	240V Crankcase Heater (Single-phase)	30
CPCRKHTR004A00	240V Crankcase Heater (Single-phase & 3-phase)	42 – 60
CPCRKHTR009A00	460V Crankcase Heater	36
CPCRKHTR005A00	460V Crankcase Heater	42 – 60
<b>LOW AMBIENT, ANTI-CYCLE TIMER, COMPRESSOR START ASSIST</b>		
CPLOWAMB001A00	Low Ambient Control – enables cooling system to operate down to 0 Deg. F by cycling condenser fan on and off.	ALL
NRTIMEGD001A00	Five Minute Compressor Delay	ALL
CPHSTART002A00	PTC Compressor Start Assist Kit (Single-phase)	ALL
<b>HAIL GUARDS / COIL PROTECTION (Factory installed on PGS models)</b>		
NAPA00501GR	3/8" spacing dense wire grilles 18"	24
NAPA00701GR	3/8" spacing dense wire grilles 16"	30
NAPA01401GR	3/8" spacing dense wire grilles 22"	36
NAPA00601GR	3/8" spacing dense wire grilles 14"	42
NAPA01201GR	3/8" spacing dense wire grilles 16"	48
NAPA01301GR	3/8" spacing dense wire grilles 24"	60

## ACCESSORIES (CONT)

<b>GAS CONVERSION KITS</b>		
NPLPCONV013C00	Natural to LP Conversion Kit ( 0 – 2000' )	ALL
NPLPCONV014C00	Natural to LP Conversion Kit ( 2001' – 6000' )	ALL
NPNGCONV004C00	LP to Natural Gas Conversion Kit ( 0 – 2000' )	ALL
<b>FLUE DISCHARGE DEFLECTOR</b>		
CRFLUEDS001A00	Directs flue gas exhaust 90 degrees upward from current discharge. Designed to allow tighter distances between unit and combustible surfaces. 24 inch Height. AGA certified.	ALL
<b>DUCT TRANSITIONS</b>		
NPDUCFLG002A00	Square to Round (1 set of 2, use with horizontal duct flanges only)	24–48
<b>LOW PRESSURE SWITCH</b>		
CPLPSCTL001A00	Low Pressure Switch Kit (Standard on 24 size)	30–60