



# 38AUM Air Cooled Condensing Units – 60Hz



Quality Assurance  
Certificate Reg. No:  
04 100 950420



Subject to change without notice

## Installation Operation Maintenance Manual

Manufacturer's Name: Saudi Airconditioning Manufacturing Co. Ltd.

Country of origin : Jeddah, Saudi Arabia

Nearest port of embarkation: Jeddah Islamic port

Product classification: Commercial and Residential

## 38AUM Air Cooled Condensing Units – 60Hz Nominal Cooling Capacity 6.0 – 15.0 Tons HFC R-410A Refrigerant

The 38AUM series outdoor air cooled condensing units matched with Carrier's 40RUM series indoor air handler's offer a wide variety of options for your HVAC application needs. Whether it's first cost with the 38AUM single compressor models or superior part load performance from the two compressor models, this series is designed for long, dependable operation as a rooftop or on-the-ground installation. All 38AUM and 40RUM series units use environmentally sound Puron® R-410A refrigerant. Together, they create a reliable split system that provides easy solutions to a wide range of commercial HVAC needs.

Contact your local Carrier representative for additional reference materials.

# TABLE OF CONTENTS

Safety Considerations.....	2
Unit Physical Data .....	4
Base Unit Dimensions .....	5
Installation Guideline .....	7
Pre-Start-Up.....	18
Start-Up.....	19
Operating Sequence.....	21
Routine System Maintenance/Service.....	22
Piping Recommendation.....	29
Electrical Data Table.....	30
Typical Wiring Schematic .....	31
Charging Chart.....	37
R-410A Refrigerant Quick Reference Guide .....	45
Air Conditioner Troubleshooting Chart .....	46
Mandatory Startup Checklist and Record.....	47

## SAFETY CONSIDERATIONS

### General

Improper installation, adjustment, alteration, service, maintenance or use can cause explosion, fire, electrical shock or other conditions which may cause personal injury or property damage. Consult a qualified installer; service agency must use factory-authorized kits or accessories when modifying this product. Refer to the individual instructions packaged with the kits or accessories when installing.

Follow all the safety codes. Wear safety glasses and work gloves. Use quenching cloths for brazing operations and have a fire extinguisher available. Read these instructions thoroughly and follow all warnings or cautions attached to the unit. Consult local building codes for special requirements. In absence of local codes, it is recommended that the USA standard ANSI/NFPA 70, National Electrical Code (NEC), be followed.

It is important to recognize safety information. This is the safety-alert symbol . When you see this symbol on the unit and in instructions or manuals, be alert to the potential for personal injury.

Understand the signal words DANGER, WARNING, CAUTION, and NOTE. These words are used with the safety-alert symbol. DANGER identifies the most serious hazards which **will** result in severe personal injury or death. WARNING signifies hazards which **could** result in personal injury or death. CAUTION is used to identify unsafe practices, which **may** result in minor personal injury or product and property damage. NOTE is used to highlight suggestions which **will** result in enhanced installation, reliability, or operation.

### Installation Safety Considerations

After the unit has been received and when it is ready to be installed or reinstalled, it must be inspected for damage. If damage is detected upon receipt, immediately file a claim with the shipping company or repair.

This machine must be installed in a location that is not accessible to the public and protected against access by non-authorized people. This machine must not be installed in an explosive atmosphere.

Do not remove the skid or the packaging until the unit is in its final position. The units can also be lifted with slings, using only the designated lifting points marked on the unit (labels on the chassis and a label with all unit handling instructions are attached to the unit). Use slings with the correct capacity, and always follow the lifting instructions on the certified drawings supplied for the unit.

Safety is only guaranteed, if these instructions are carefully followed. If this is not the case, there is a risk of material deterioration and injuries to personnel. These units are not designed to be lifted from above.

### Warranty

Warranty is based on the general terms and conditions of the manufacturer. Any modifications to the design and/or installation made without discussion with Carrier and without advance written agreement will result in the loss of the right to any warranty claims and any claim for injury to personnel as a result of these modifications.

 <b>WARNING</b>
<b>ELECTRIC SHOCK HAZARD</b>
Failure to follow this warning could cause personal injury or death. Before performing service or maintenance operations on unit, always turn off main power switch to unit and install lockout tag. Unit may have more than one power switch.

 <b>CAUTION</b>
<b>CUT HAZARD</b>
Failure to follow this warning could cause personal injury. Sheet metal parts may have sharp edges or burrs. Use care and wear appropriate protective clothing, safety glasses and gloves when handling parts and servicing air conditioning equipment

 <b>WARNING</b>
<b>UNIT OPERATION AND SAFETY HAZARD</b>
Failure to follow this warning could cause personal injury, death and /or equipment damage. Puron® (R-410A) refrigerant systems operate at higher pressures than standard R-22 systems. Do not use R-22 service equipment or components on Puron® refrigerant equipment.

 <b>WARNING</b>
<b>PERSONAL SAFETY AND ENVIRONMENTAL HAZARD</b>
Failure to follow this warning could cause personal injury or death damage. Relieve pressure and recover all refrigerant before system repair or final unit disposal. Wear safety glasses and gloves when handling refrigerants. Keep torches and other ignition sources away from refrigerants and oils.

## UNIT PHYSICAL DATA (ENGLISH UNITS)

Unit 38AUM	Z07	Z08	D12	D14	D16
<b>Refrigeration System</b>	Puron R-410A ®				
No. of Ckt / No. of Comp. / Type	1 / 1 / Scroll		2 / 2 / Scroll		
Initial Charge per Circuit (lbs)					
230V-3Ph-60Hz	8.20	9.70	5.73 / 6.39	8.37 / 9.04	11.57 / 13.22
400V-3Ph-60Hz	9.65	9.10	5.42 / 6.35	11.68 / 13.28	8.38 / 9.04
460V-3Ph-60Hz	8.82	9.06	5.90 / 6.30	8.40 / 8.90	11.60 / 13.10
Operating Charge per Circuit (lbs)					
230V-3Ph-60Hz	13.67	16.07	9.52 / 10.64	14.09 / 14.97	19.31 / 22.04
400V-3Ph-60Hz	16.09	15.17	9.04 / 10.58	19.31 / 21.96	14.08 / 14.97
460V-3Ph-60Hz	14.70	15.10	9.90 / 10.56	14.00 / 14.9.0	19.30 / 21.90
Metering Device	TXV				
High - Pressure Trip / Reset (PSIG)	630 / 505				
Low - Pressure Trip / Reset (PSIG)	54 / 117				
<b>Condenser Coil</b>	RTPF - Round Tube / Plate Fin Coil Design				
Material (Fin / Tube)	Al/Cu				
Fin Type	Double Wavy				
Rows / FPI	2 / 17		3 / 17		2 / 17
Total Face Area (ft²)	17.5		25.1		31.8
<b>Condenser Fan &amp; Motor</b>					
Qty. / Motor Drive Type	2 / Direct				
Motor HP / RPM					
230/400/460V-3Ph-60Hz	1/4 / 1100				1/2 / 1075
Fan Diameter (mm)	559				660

## UNIT PHYSICAL DATA (SI UNITS)

Unit 38AUM	Z07	Z08	D12	D14	D16
<b>Refrigeration System</b>	Puron R-410A ®				
No. of Ckt / No. of Comp. / Type	1 / 1 / Scroll		2 / 2 / Scroll		
Initial Charge per Circuit (kg)					
230V-3Ph-60Hz	3.72	4.40	2.60 / 2.90	3.80 / 4.10	5.25 / 6.0
400V-3Ph-60Hz	4.38	4.13	2.46 / 2.88	5.30 / 6.0	3.80 / 4.10
460V-3Ph-60Hz	4.02	4.13	2.70 / 2.88	3.84 / 4.08	5.26 / 5.96
Operating Charge per Circuit (kg)					
230V-3Ph-60Hz	6.20	7.29	4.32 / 4.83	6.39 / 6.79	8.76 / 10.0
400V-3Ph-60Hz	7.30	6.88	4.10 / 4.80	8.76 / 9.96	6.39 / 6.79
460V-3Ph-60Hz	6.70	6.88	4.50 / 4.80	6.39 / 6.79	8.76 / 9.96
Metering Device	TXV				
High - Pressure Trip / Reset (Bar)	43 / 34				
Low - Pressure Trip / Reset (Bar)	4 / 8				
<b>Condenser Coil</b>	RTPF - Round Tube / Plate Fin Coil Design				
Material (Fin / Tube)	Al/Cu				
Fin Type	Double Wavy				
Rows / FPI	2 / 17		3 / 17		2 / 17
Total Face Area (m²)	1.63		2.33		2.95
<b>Condenser Fan &amp; Motor</b>					
Qty. / Motor Drive Type	2 / Direct				
Motor HP / RPM					
230/400/460V-3Ph-60Hz	1/4 / 1100				1/2 / 1075
Fan Diameter (in)	22				26

# BASE UNIT DIMENSIONS – 38AUM Series Size Z07-D14

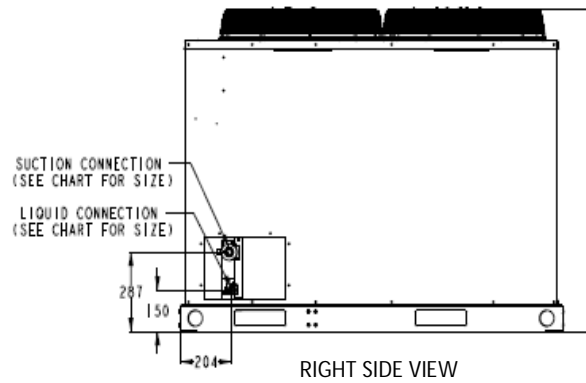
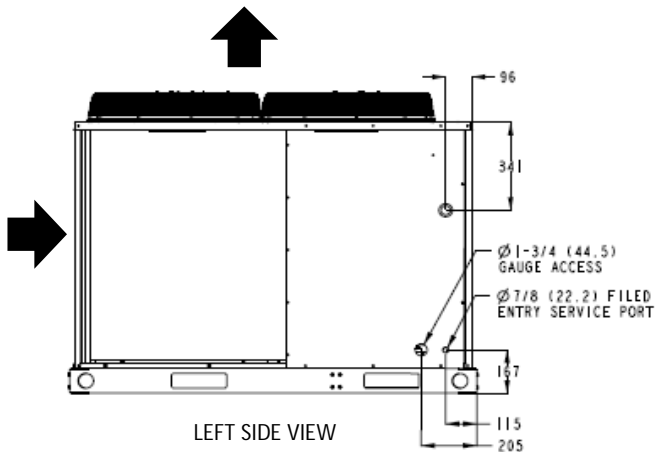
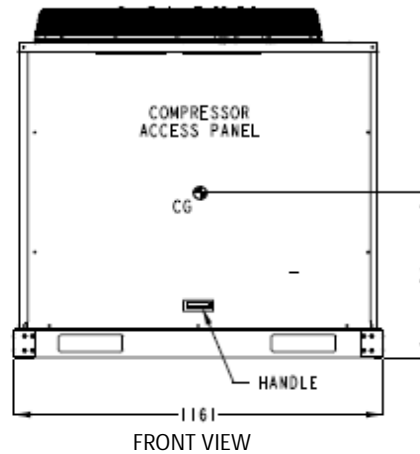
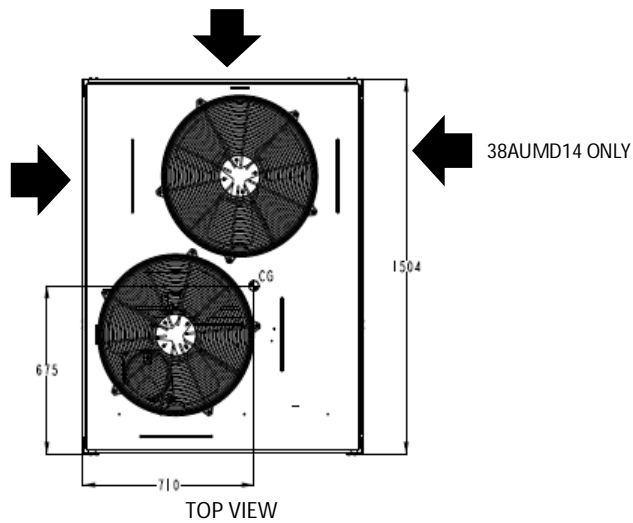

Unit 38AUM	Unit Weight (kg)	Height (mm)	Center of Gravity (mm)			Service Valve Connections	
		H	X	Y	Z	Suction	Liquid
Z07	176.0	1165.0	457.2	609.6	533.4	1-1/8	3/8
Z08	177.0	1165.0	457.2	609.6	533.4	1-1/8	1/2
D12	234.0	1368.0	584.2	609.6	1279.2	1-1/8	3/8
D14	297.0	1368.0	508.0	635.0	1279.2	1-1/8	1/2

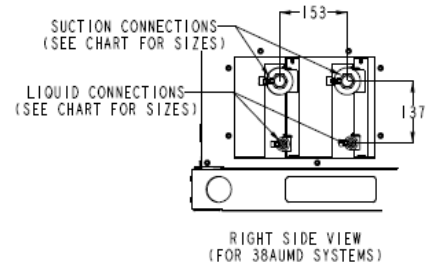

- Center Of Gravity
- Direction of Air Flow

## NOTES:

1. Minimum clearance (Local codes or jurisdiction may prevail):
  - A. Bottom to combustible surfaces: 0 inches
  - B. Outdoor coil, for proper airflow: 36 inches one side, 12 inches the other. The side getting the greater clearance is optional.
  - C. Overhead: 60 inches, to assure proper outdoor fan operation.
  - D. Between units: Control box side: 42 inches per NEC.
  - E. Between unit and ungrounded surfaces: Control box side, 36 inches per NEC.
  - F. Between unit and block or concrete walls and other grounded surfaces: Control box side 42 inches per NEC.
2. With exception of the clearance for the outdoor coil as stated in note 1B, are movable fence or barricade requires no clearance.
3. Units may be installed on combustible floors made from wood or Class A, B or C roof covering material.

# BASE UNIT DIMENSIONS – 38AUM Series Size D16

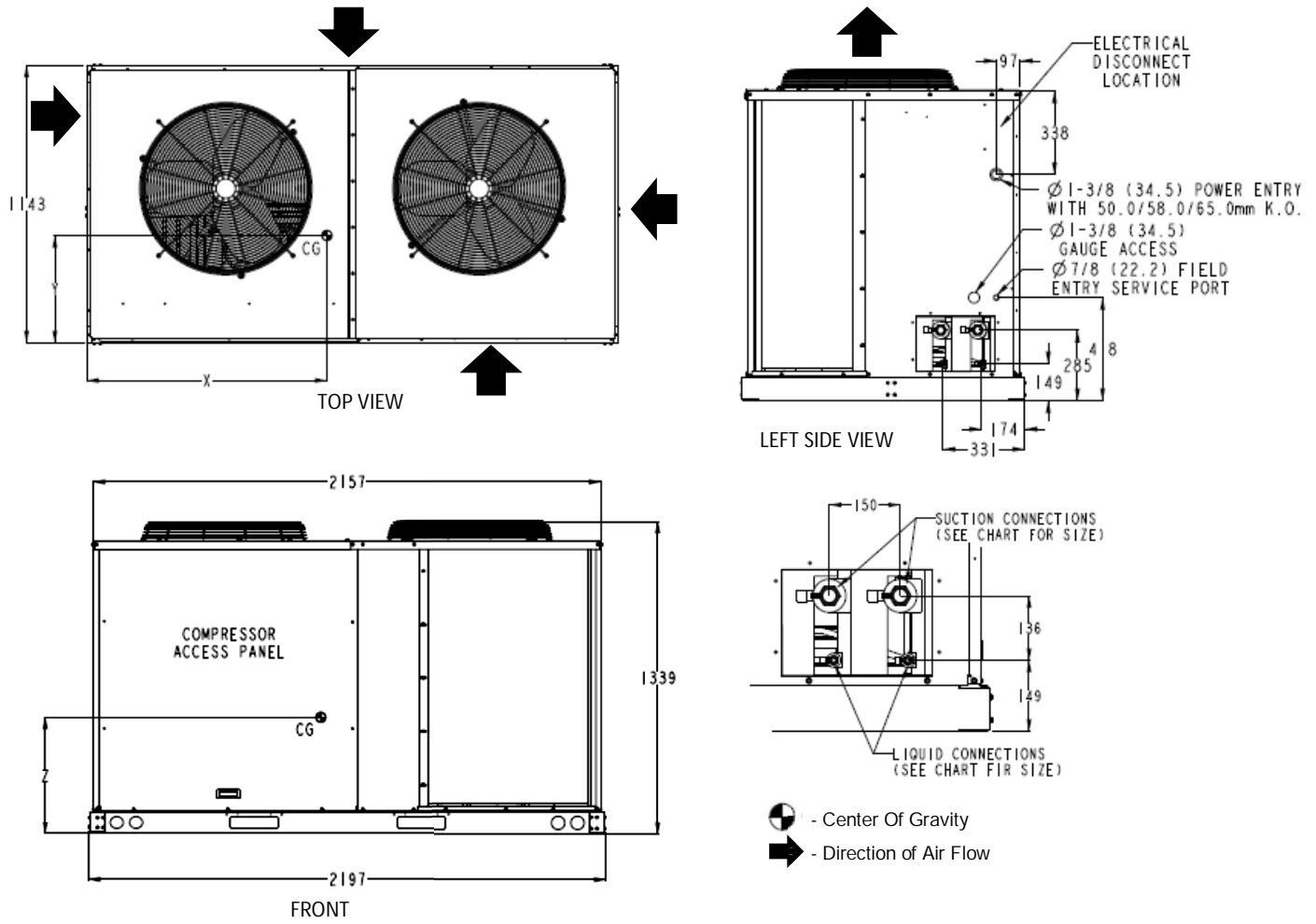

Unit 38AUM	Unit Weight (kg)	Height (mm)	Center of Gravity (mm)			Service Valve Connections	
			H	X	Y	Z	Suction
D16	332.0	1165.0	457.2	609.6	533.4	1-3/8	1/2

**NOTES:**

- Minimum clearance (Local codes or jurisdiction may prevail):
  - Bottom to combustibles surfaces: 0 Inches
  - Outdoor coil, for proper airflow: 36 inches one side, 12 inches the other. The side getting the greater clearance is optional.
  - Overhead: 60 inches, to assure proper outdoor fan operation.
  - Between units: control box side: 42 inches per NEC.
  - Between unit and ungrounded surfaces: Control box side, 36 inches per NEC.
  - Between unit and block or concrete walls and other grounded surfaces: Control box side 42 inches per NEC.
- With exception of the clearance for the outdoor coil as stated in note 1B, are movable fence or barricade requires no clearance.
- Units may be installed on combustible floor made from wood or Class A, B or C roof covering material.

# INSTALLATION GUIDELINE

## Replacement/Retrofit – R-22 to Puron®

Replacement/retrofit installations require change-out of outdoor unit, metering device, and filter driers. Change-out of indoor coil (evaporator) and interconnecting tubing is recommended.

**Existing evaporator coil** – If the existing evaporator coil may be re-used, check with the coil manufacturer to verify the coil construction is suitable for operation with the higher pressures of Puron® (R-410A). Also determine if the existing TXV valve is compatible with R-410A, replace if necessary. The minimum factory test pressure rating must be 2413 kPa (350 psig). Existing coil will need to be purged with Nitrogen to remove as much mineral oil as possible to eliminate cross contamination of oils.

**Acid test** – If the existing system is being replaced because of a compressor electrical failure, assume acid is in system. If system is being replaced for any other reason, use an approved acid test kit to determine acid level. If even low levels of acid are detected, install a 100 percent activated alumina suction-line filter drier in addition to the replacement liquid-line filter drier. Remove the suction line filter drier as soon as possible, with a maximum of 72 hr of operation. Recommendation: Install a ball valve in the liquid line at the filter drier location when installing a suction filter in the suction line.

**Existing refrigeration piping** – Reuse of existing refrigerant piping involves three issues: quality (strength) of existing tubing, cleanliness and tube size. Inspect all tube segments and joints for signs of damage, corrosion or poor brazing. Flush the interconnecting piping system with dry Nitrogen to eliminate as much trace of mineral oil as possible.

Same tube sizes are capable of handling higher flow rates (expressed as tons of cooling capacity) with Puron refrigerant compared to R-22 at constant pressure drops. For example, a 1/2-inch OD liquid line is rated at 33% higher tons with Puron® than with R-22 (at 5° pressure drop). A 1 1/8-inch OD suction line is rated at 53% higher tons with Puron® than with R-22 (at 2° pressure drop). Refrigeration lines selected for R-22 use are typically oversized for Puron® applications. Carefully check the existing suction line size against the table for maximum size (see Table Piping Recommendation); replace vertical riser segments if necessary. Check existing liquid line size against sizing data (see Table Piping Recommendation); replace with smaller lines when feasible.

## Installation

1. Remove the existing evaporator coil or fan coil and install the replacement coil when appropriate.
2. Drain oil from low points and traps in suction line tubing (and hot gas bypass tubing if appropriate) and evaporator if they were not replaced. Removing oil from evaporator coil may require purging of the tubing with dry nitrogen.
3. Unless indoor unit is equipped with a Puron® approved metering device, change the metering device to a thermal expansion valve (TXV) designed for Puron® (R-410A).
4. Remove the existing outdoor unit. Install the new outdoor unit according to these installation instructions.
5. Install a new field-supplied liquid-line filter drier at the indoor coil just upstream of the TXV or fix orifice metering device.
6. If a suction line filter drier is also to be installed, install suction line drier downstream of suction line service valve at condensing unit.



## CAUTION

### UNIT DAMAGE HAZARD

Failure to follow this caution may result in equipment damage.

Never install suction-line filter drier in the liquid-line of a Puron® system.

7. If required, install a 100% activated alumina suction line filter drier at the outdoor unit.
8. Evacuate and charge the system according to the instructions in this installation manual.
9. Operate the system for 10 hr. Monitor the pressure drop across the suction line filter drier. If pressure drop exceeds 21kPa (3 psig), replace suction-line and liquid-line filter driers. Be sure to purge system with dry nitrogen and evacuate when replacing filter driers. Continue to monitor the pressure drop across suction-line filter drier. Repeat filter changes is necessary. Never leave suction-line filter drier in system longer than 72 hr (actual time).

## Matching 38AUM Model to Evaporator Coil

The Model 38AUMZ is a single-circuit unit design, requiring one set of refrigeration piping. This model can be connected to an evaporator coil with one circuit or with two circuits (by manifolding the evaporator connections into a single piping system). The Model 38AUMD is a dual-circuit unit design that requires two sets of refrigeration piping between the outdoor unit and the evaporator coil (or coils). This model can only be connected to an evaporator coil that has two refrigeration circuits (or to two separate evaporator coils). The Model 38AUMD CANNOT be connected to a single-circuit evaporator coil. The Model 38AUMD CANNOT be field-converted to a single-circuit design. Before unpacking this new 38AUM model, compare the evaporator coil design to the 38AUM model.

### Evaporator Coil Connections

Evaporator Coil has	Connect to Model	Notes
Single Circuit	38AUMZ	
Two Circuits	38AUMD	Use two separate piping systems

## NEW INSTALLATION

### Jobsite Survey

Complete the following checks before installation.

1. Consult local building codes or the U.S.A. National Electrical Code (Ref: ANSI/NFPA 70, [American National Standards Institute/National Fire Protection Association], latest revision) for special installation requirements
2. Determine unit location (from project plans) or select unit location.
3. Check for possible overhead obstructions which may interfere with unit lifting or rigging.

### Step 1 — Plan for Unit Location

Select a location for the unit and its support system (pad, rails or other) that provides for the minimum clearances required for safety. This includes the clearance to combustible surfaces, unit performance and service access below, around and above unit as specified in unit drawings. See Service Clearance Dimensional Drawing.

**NOTE:** Local codes may require different clearances than specified in Service Clearance Dimensional Drawing. It is the responsibility of installers to be knowledgeable in local codes and to modify the recommended clearances to satisfy local codes.

**NOTE:** Consider also the effect of adjacent units on airflow performance and control box safety clearance.

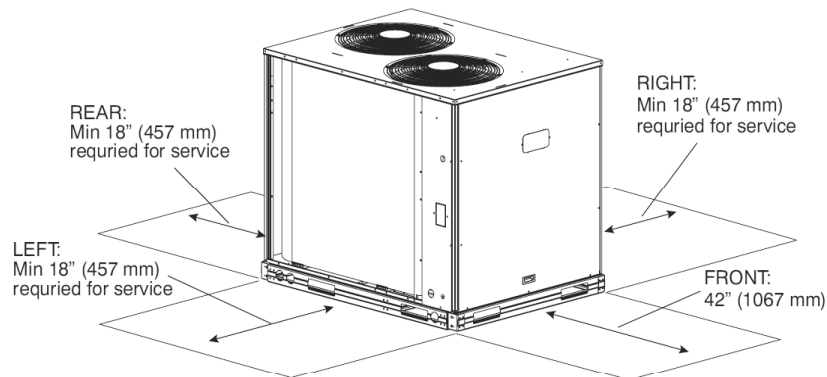

Note: Observe requirements for 39" (914 mm) operating clearance on either Left or Rear coil opening.

**Fig: - Service Clearance Dimensional Drawing**

Do not install the outdoor unit in an area where fresh air supply to the outdoor coil may be restricted or when recirculation from the condenser fan discharge is possible. Do not locate the unit in a well or next to high walls. Evaluate the path and required line length for interconnecting refrigeration piping, including suction riser requirements (outdoor unit above indoor unit), liquid line lift (outdoor unit below indoor unit) and hot gas bypass line. Relocate sections to minimize the length of interconnecting tubing.

Although unit is weatherproof, avoid locations that permit water from higher level runoff and overhangs to fall onto the unit.

**DO NOT BURY REFRIGERATION LINES.**



## Step 2 — Complete Pre-Installation Checks

**Check Unit Electrical Characteristics:** Confirm before installation of unit that voltage, amperage and circuit protection requirements listed on unit data plate agree with power supply provided.

**Un-crate Unit:** Remove unit packaging except for the top skid assembly, which should be left in place until after the unit is rigged into its final location.

**Inspect Shipment:** File a claim with shipping company if the shipment is damaged or incomplete.

### Consider System Requirements:

- Consult local building codes or the U.S.A. National Electrical Code (Ref: ANSI/NFPA 70, [American National Standards Institute/National Fire Protection Association], latest revision) for special installation requirements.
- Allow sufficient space for airflow clearance, wiring, refrigerant piping, and servicing unit. See Unit Dimensional Drawing for unit dimensions and weight distribution data.
- Locate the unit so that the outdoor coil (condenser) airflow is unrestricted on all sides and above.
- The unit may be mounted on a level pad directly on the base channels or mounted on raised pads at support points. See Unit Dimensional Drawing for unit operating weights and for weight distribution based on recommended support points.

**NOTE:** If vibration isolators are required for a particular installation, use the data in Unit Dimensional Drawing to make the proper selection.

## Step 3 — Prepare Unit Mounting Support

**Slab Mount** — Provide a level concrete slab that extends a minimum of 150 mm (6 in.) beyond unit cabinet. Install a gravel apron in front of condenser coil air inlet to prevent grass and foliage from obstructing airflow.

## Step 4 — Rig and Mount the Unit

 **CAUTION**

**UNIT DAMAGE HAZARD**

Failure to follow this caution may result in equipment damage.

All panels must be in place when rigging. Unit is not designed for handling by fork truck.

**Rigging:** These units are designed for overhead rigging. Refer to the rigging label for preferred rigging method. Spreader bars are not required if top crating is left on the unit. All panels must be in place when rigging. As further protection for coil faces, plywood sheets may be placed against the sides of the unit, behind cables. Run cables to a central suspension point so that the angle from the horizontal is not less than 45 degrees. Raise and set the unit down carefully. If it is necessary to roll the unit into position, mount the unit on longitudinal rails, using a minimum of 3 rollers. Apply force to the rails, not the unit. If the unit is to be skidded into position, place it on a large pad and drag it by the pad. Do not apply any force to the unit. Raise from above to lift the unit from the rails or pad when unit is in its final position. After the unit is in position, remove all shipping materials and top crating.

## Step 5 — Complete Refrigerant Piping Connections

**IMPORTANT:** Do not bury refrigerant piping underground.

**IMPORTANT:** A refrigerant receiver is not provided with the unit. Do not install a receiver.

### Provide Safety Relief

If local codes dictate an additional safety relief device, purchase locally and install locally. Installation will require the recovery of the factory shipping charge before the factory tubing can be cut and the supplemental relief device is installed. Model 38AUMD has two separate refrigeration systems. If required, each circuit will require a field-supplied/installed supplemental relief device.

## Check 38AUM Model with Evaporator Coil Connections

Confirm before installation of unit that the evaporator coil connections are consistent with this 38AUM model.

## Determine Refrigerant Line Sizes

Select the recommended line sizes for 38AUMZ and 38AUMD unit from the appropriate tables. Determine the linear length of interconnecting piping required between the outdoor unit and indoor unit (evaporator). Consider and identify also the arrangement of the tubing path (quantity and type of elbows in both lines), liquid line solenoid size, filter drier and any other refrigeration specialties located in the liquid line. Refer to the indoor unit installation instructions for additional details on refrigeration specialties devices. Determine equivalent line length adjustments for path and components and add to linear line lengths. See Equivalent Lengths for Common Fittings (EN units), Equivalent Lengths for Common Fittings, for usual fitting types. Also identify adjustments for refrigeration specialties. Refer to Part 3 of the Carrier System Design Manual for additional data and information on equivalent lengths.

### Equivalent Lengths for Common Fittings (EN units)

mm Ref	Nominal Tube OD (in)	Elbows					mm Ref	Nominal Tube OD (in)	Branch Flow	Tees		
		90° Std	90° Lrad	90° Street	45° Std	45° Street				Straight-Thru		
									No Reduct	Reduce 25%	Reduce 50%	
9.5	3/8	0.40	0.24	0.67	0.18	0.30	9.5	3/8	0.79	0.24	0.34	0.40
12.7	1/2	0.43	0.27	0.70	0.21	0.34	12.7	1/2	0.82	0.27	0.37	0.43
15.9	5/8	0.49	0.30	0.76	0.24	0.40	15.9	5/8	0.91	0.30	0.43	0.49
19.1	3/4	0.55	0.37	0.88	0.27	0.46	19.1	3/4	1.07	0.37	0.52	0.55
22.2	7/8	0.61	0.43	0.98	0.27	0.49	22.2	7/8	1.22	0.43	0.58	0.61
28.6	1 - 1/8	0.79	0.52	1.25	0.40	0.64	28.6	1 - 1/8	1.52	0.52	0.70	0.79
34.9	1 - 3/8	1.01	0.70	1.71	0.52	0.91	34.9	1 - 3/8	2.13	0.70	0.94	1.01
41.3	1 - 5/8	1.22	0.79	1.92	0.64	1.04	41.3	1 - 5/8	2.44	0.79	1.13	1.22
54.0	2 - 1/8	1.52	1.01	2.50	0.79	1.37	54.0	2 - 1/8	3.05	1.01	1.43	1.52

**NOTE:** Equivalent line lengths will vary based on tube diameter. Calculate equivalent line length for each pipe by adding equivalent length adjustments to linear lengths for each pipe. Enter the appropriate table to select the recommended line sizes.

Model:	Line Sizes Table	Quality of Line Sets
38AUMZ	5	1
38AUMD	6	2

## Liquid Lift

A liquid lift condition exists when the outdoor unit is located below the indoor (evaporator) unit and liquid flows vertically up in a portion of the liquid line. The vertical column of liquid reduces the available state point subcooling at the evaporator coil's thermal expansion valve. This effect reduces the length of liquid lift (feet of elevation) that a liquid line size can accommodate. Longer linear tube lengths will also reduce the amount of liquid lift possible. Check Table Piping Recommendation for maximum liquid lift capabilities for line sizes. Reselect the liquid line tube size if necessary. If maximum available tube size cannot provide the required lift distance on this installation, relocate the outdoor unit to reduce the equivalent line length or the lift requirement.

## Suction Riser

A suction riser condition exists when the outdoor unit is located above the indoor (evaporator) unit and suction vapor must flow vertically up to return to the compressor. Oil return is a concern when the suction tube size is too large to produce the minimum refrigerant velocity to ensure oil return at minimum load conditions. Check Table 38AUM Maximum Suction Pipe Size for maximum suction tube size for 38AUM units at minimum load conditions. Consider suction speed riser (reduced tube size for vertical segment only) or double suction riser arrangement if the proposed suction tube size does not provide necessary minimum flowrates for this riser.

### 38AUM Maximum Suction Pipe Size

Model:	Unit Size	Maximum Tube Size
38AUMZ	07	1 - 3/8
	08	1 - 5/8
38AUMD	12	1 - 3/8
	14	1 - 3/8
	16	1 - 3/8

### Vertical Separation (outdoor unit above indoor unit)

Vertical elevation difference of 60 m (200 ft) is permitted when the outdoor unit (38AUMZ or 38AUMD) is located above the indoor unit.

### Insulate Suction Lines

Apply closed-cell tubular insulation to all suction lines between evaporator coil connection and 38AUM unit's suction service valve.

### Hot Gas Bypass

Hot gas bypass, if used, should be introduced before the evaporator. (A bypass route that also bypasses the evaporator circuit may lead to oil trapping in the evaporator circuit during low load conditions and then to oil slugging as evaporator load increases.) Model 38AUM units do not include a hot gas stub connection; a tee must be field-supplied and installed in the compressor discharge line. Run a 1/2-in OD line between outdoor unit and evaporator coil inlet. Install an Auxiliary Side Connector at the evaporator between TXV and distributor (follow instructions for the side connector part). Insulate the hot gas line.

**38AUMD:** Generally only one hot gas bypass system will be applied on a two-circuit unit. Connect the hot gas bypass system to Circuit 1 (first-on/last-off, connected to the evaporator coil's bottom circuit).

### 38AUMD Piping Connections

The 38AUMD's two circuits are designated Circuit 1 and Circuit 2. Circuit 1 is controlled by the thermostat's Y1 (or TC1) contact and will be the first circuit on and last circuit off. Circuit 2 is controlled by the thermostat's Y2 (or TC2) contact and this circuit is always the "lag" circuit.

See Fig. 38AUMD Service Valve Locations for location of Circuit 1 and Circuit 2 service valves and field piping connections. Circuit 1 is on the right-hand side of the service valve compartment; Circuit 2 is on the left. When a single piece evaporator coil with two separate circuits is connected to a 38AUMD, the lower coil circuit should be connected to the 38AUMD's Circuit 1 so that the evaporator's lower coil segment is first-on/last-off (to avoid re-evaporation of condensate on dry lower coil segments).

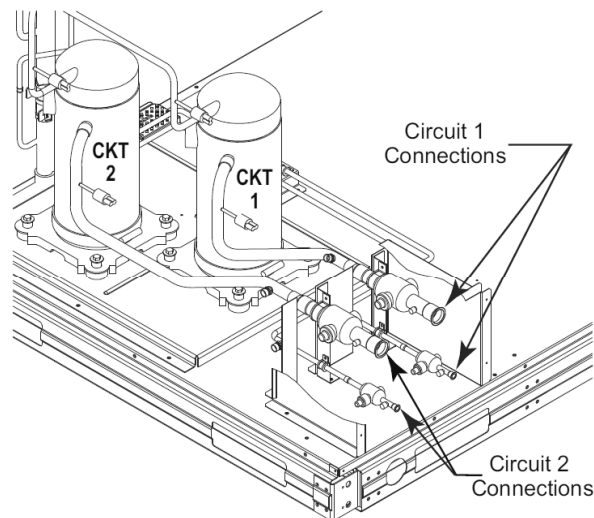

**Fig: - 38AUMD Service Valve Locations**

Plan the Circuit 1 and Circuit 2 tubing segments carefully, mark each segment and check constantly as piping systems are assembled to avoid piping errors.

38AUMD unit cannot be field-piped as a single-circuit/tandem system.

**Connecting 40RUM to 38AUMD:** The 40RUM fan coil in sizes 12, 14 and 16 is a face-split coil design that also has its circuits designated as 1 and 2. See Fig: - Typical Evaporator Coil Connections (40RUM). Note that the lower coil segment changes as the arrangement of the 40RUM changes. In a vertical arrangement, the 40RUM's lower coil segment is segment 2; this segment should be connected to the 38AUMD's Circuit 1. In a horizontal arrangement, the 40RUM's lower segment is now segment 1; this segment should be connected to the 38AUMD's Circuit 1.

Note that refrigerant suction piping should be insulated.

40RUM Arrangement	Cooling Stage	40RUM Coil Segment	Connect to 38AUMD
Vertical	Y1	2	Circuit 1
	Y2	1	Circuit 2
Horizontal	Y1	1	Circuit 1
	Y2	2	Circuit 2

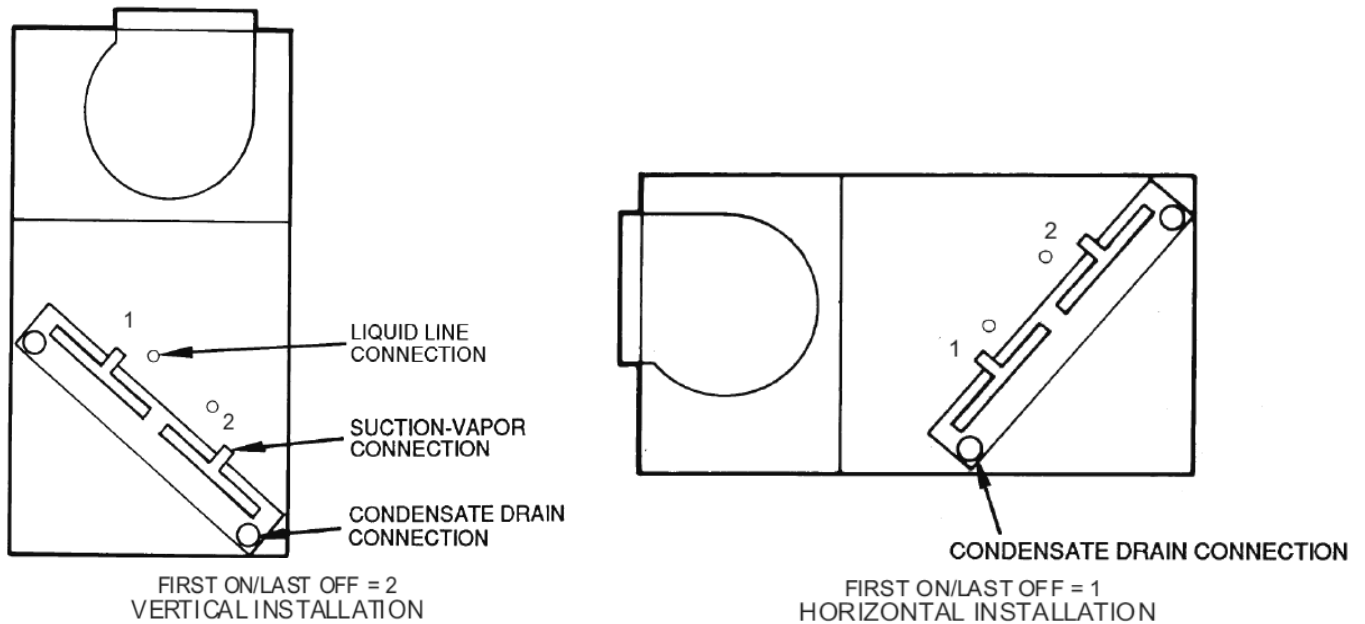

**Fig: - Typical Evaporator Coil Connections (40RUM)**

**Install Filter Drier(s) and Moisture Indicator(s)**

Every unit MUST have a filter drier in the liquid line. 38AUMD models require two filter driers (one in each liquid line). Locate the filter drier(s) at the indoor unit, close to the evaporator coil's thermal expansion valve (TXV) inlets.

Installation of liquid line moisture indicating sightglass in each circuit is recommended. Locate the sightglass(es) between the outlet of the filter drier and the TXV inlet. In some applications, depending on space and convenience requirements, it may be desirable to install 2 filter driers and sight glasses in a single circuit application. One filter drier and sight glass may be installed at A locations

Select the filter drier for maximum unit capacity and minimum pressure drop. Complete the refrigerant piping from the indoor unit to the outdoor unit before opening the liquid and suction lines at the outdoor unit.

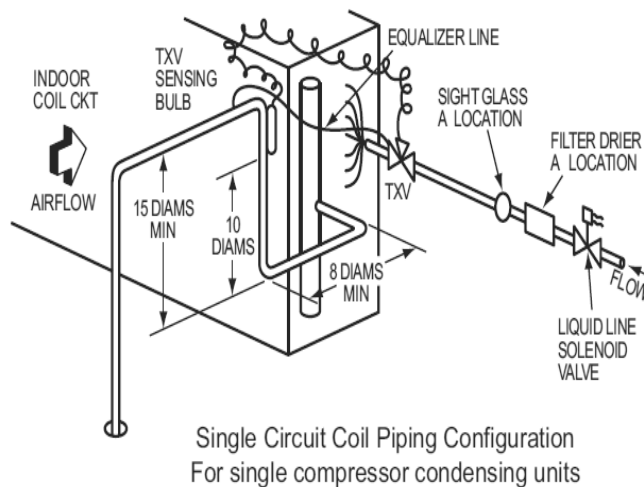

**Fig: - Location of Sight Glass(es) and Filter Driers Typical 38AUMZ Systems**

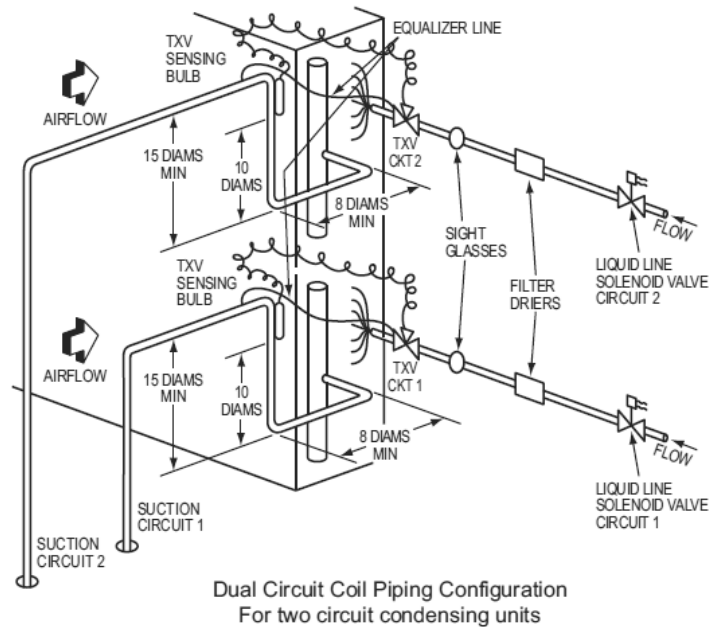

**Fig: - Location of Sight Glass(es) and Filter Driers Typical 38AUMD Systems**

### Install Liquid Line Solenoid Valve

It is recommended that a solenoid valve be placed in the main liquid line (see Figs: - Location of Sight Glass(es) and Filter Driers Typical 38AUMZ/D Systems) between the condensing unit and the evaporator coil. Locate the solenoid valve at the outlet end of the liquid line, near the evaporator coil connections, with flow direction arrow pointed at the evaporator coil. (A liquid line solenoid valve is required when the liquid line length exceeds 23m [75ft].) This valve prevents refrigerant migration (which causes oil dilution) to the compressor during the off cycle, at low outdoor ambient temperatures.

**Solenoid drop control wiring:** control the power to the liquid line solenoid through a Solenoid Valve Relay (SVR) in all units. Use part number HN61PC005 (field--supplied, installed). 38AUMZ unit requires one SVR; 38AUMD unit requires two relays. 38AUMD units also require a separate control power transformer for the liquid solenoid valve loads. Use transformer part number HT01BD602, according to unit power supply.

Mount the SVR (and transformer TRAN3 when used) in unit control box. Connect per wiring schematic label on unit or per Typical Wiring Schematic.

**Capacity Control Liquid Line Solenoid Valve:** Evaporator capacity staging control via direct thermostat control of a liquid solenoid valve on the evaporator's second stage circuit is not possible with 38AU models. If this installation is a retrofit for a unit that included automatic pressure-operated unloading, check the existing thermostat and liquid solenoid valve wiring for possible direct thermostat control of a solenoid valve; re-wire per Fig: - Typical Piping Connection Assembly.

**Selecting an Accumulator** – Because all 38AUM models use scroll compressors, an accumulator is not required. If an accumulator is to be added, check the accumulator manufacturer's literature carefully for indication of its suitability for use with R--410A; look for minimum working pressure of 1380 kPa (200 psig). Select the accumulator first on the basis of its cataloged minimum capacity (tons) to ensure oil return from the accumulator, then on tube size or holding capacity.

**Make Piping Connections** — Piping connections at the 38AUM unit are ball valves with stub tube extensions. Do not open the unit service valves until all interconnecting tube brazing has been completed. The stub tube connections include 1/4-in SAE service fittings with Schrader valve cores (see Fig: - Typical Piping Connection Assembly). Before making any brazed connections to the unit service valves, remove both Schrader valve caps and cores and save for re-installation. Connect a source for nitrogen to one of these service fittings during tube brazing to prevent the formation of copper oxides inside the tubes at brazed joints.

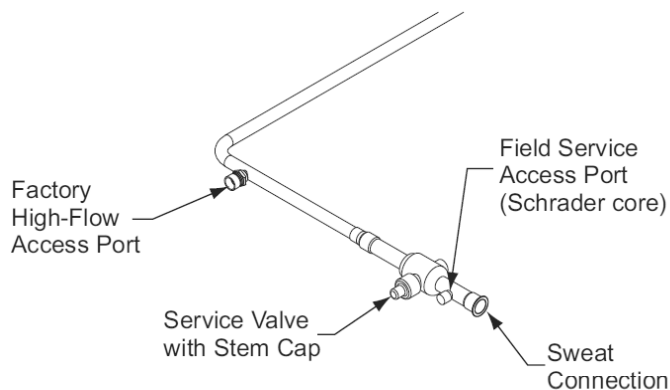

**Fig: - Typical Piping Connection Assembly**

When connecting the field tubing to the 38AU service valves, wrap the valves in wet rags to prevent overheating. Pressure-test all joints from outdoor unit connections over to the evaporator coil, using nitrogen as pressure and with soap-and-bubbles. When pressure-testing is completed, remove the nitrogen source at the outdoor unit service valves and re-install the two Schrader valve cores. Torque the cores to 23-34 N-cm (2-3 in-lbs).

**Evacuation/Dehydration** — Evacuate and dehydrate the connected refrigeration system(s) (excluding the 38AUM unit) to 500 microns using a two-stage vacuum pump attached to the service ports outside the 38AU service valves, following description in GTAC II, Module 4, System Dehydration.



## WARNING

**UNIT OPERATION AND SAFETY HAZARD**

Failure to follow this warning could cause personal injury, death and/or equipment damage.

Puron® (R-410A) refrigerant systems operate at higher pressure than standard R-22 systems. Do not use R-22 service equipment or components on Puron refrigerant equipment.

This unit is designed for use with Puron (R-410A) refrigerant. Do not use any other refrigerant in this system.

Puron (R-410A) refrigerant is provided in pink (rose) colored cylinders. These cylinders are available with and without dip tubes; cylinders with dip tubes will have a label indicating this feature. For a cylinder with a dip tube, place the cylinder in the upright position (access valve at the top) when removing liquid refrigerant for charging. For a cylinder without a dip tube, invert the cylinder (access valve on the bottom) when removing liquid refrigerant.

Because Puron (R-410A) refrigerant is a blend, it is strongly recommended that refrigerant always be removed from the cylinder as a liquid. Admit liquid refrigerant into the system in the discharge line. If adding refrigerant into the suction line, use a commercial metering/expansion device at the gauge manifold; remove liquid from the cylinder, pass it through the metering device at the gauge set and then pass it into the suction line as a vapor. Do not remove Puron (R-410A) refrigerant from the cylinder as a vapor.

**Preliminary Charge** — Before starting the unit, charge R-410A liquid refrigerant into the high side of each 38AUM circuit through the liquid service valve(s). The amount of refrigerant added must be compatible with the operating charge listed in Table Piping Recommendation for LINEAR line length LESS the factory charge quantity (if factory shipping charge has not been removed). See example below.

**Note:** See section "Adjust Refrigerant Charge" for details on refrigerant charge adjustment.

Allow high and low side pressures to equalize. If pressures do not equalize readily, charge R-410A vapor (using special service manifold with expansion device) into the suction line service port for the low side of system to assure charge in the evaporator. Refer to GTAC II, Module 5, Charging, Recover, Recycling, and Reclamation for liquid charging procedures.

Example:  
38AUMD16  
60-ft (18.3 m) linear line length  
Equivalent line length 90-ft (27.4 m)  
Liquid Lift: 20-ft (6.1 m)  
Select line sizes from Table Piping Recommendation (38AUMD):  
Liquid 1/2 in  
Suction 1-1/8 in.  
Charge  
Circuit 1: 24.5 lbs (at 75-ft linear length)  
Circuit 2: 22.9 lbs  
Initial charge = 60% of Operating Charge:  
Circuit 1:  $0.60 \times 21.0 = 14.7$  lbs  
Circuit 2:  $0.60 \times 19.3.0 = 13.7$  lbs  
Field-Charge  
Circuit 1:  $24.5 - 14.7 = 9.8$  lbs  
Circuit 2:  $22.9 - 13.7 = 9.2$  lbs

For linear line lengths longer than 125 ft (38 m), contact your local Carrier representative for system charge value.

### Step 7 — Install Accessories

Accessories requiring modifications to unit wiring should be completed now. These accessories may include Winter Start controls and Low Ambient controls. Refer to the instructions shipped with the accessory.

### Step 8 — Complete Electrical Connections



## WARNING

### ELECTRICAL SHOCK HAZARD

Failure to follow this warning could cause personal injury or death.

Do not use gas piping as an electrical ground. Unit cabinet must have an uninterrupted, unbroken electrical ground to minimize the possibility of personal injury if an electrical fault should occur. This ground may consist of electrical wire connected to unit ground lug in control compartment, or conduit approved for electrical ground when installed in accordance with NEC (National Electrical Code), and local electrical codes.

**Note:** Check all factory and field electrical connections for tightness. Field-supplied wiring shall conform with the limitations of 63°F (33°C) rise.

**All Units** — All field wiring must comply with NEC and all local codes. Size wire based on MCA (Minimum Circuit Amps) on the unit informative plate. See Fig: Power Wiring Connections for power wiring connections to the unit contactor and terminal block and equipment ground. Provide a ground-fault and short-circuit over-current protection device (fuse or breaker) per NEC Article 440 (or local codes). Refer to unit informative data plate for MOCP (Maximum Over-current Protection) device size. Refer to unit label diagram for line-side information. Affix the crankcase heater warning sticker to the unit disconnect switch.



## WARNING

### ELECTRICAL OPERATION HAZARD

Failure to follow this warning could cause in personal injury or death.

Using unit-mounted convenience outlets: Units with unit-mounted convenience outlet circuits will often require that two disconnects be opened to de-energize all power to the unit. Treat all units as electrically energized until the convenience outlet power is also checked and de-energization is confirmed. Observe National Electrical Code Article 210, Branch Circuits.

**All Units** — Voltage to compressor terminals during operation must be within voltage range indicated on unit nameplate. See Electrical Data Table. On 3-phase units, voltages between phases must be balanced within 2% and the current within 10%. Use the formula shown in the legend for Electrical Data Table to determine the percent of voltage imbalance. Operation on improper line voltage or excessive phase imbalance constitutes abuse and may cause damage to electrical components. Such operation would invalidate any applicable Carrier warranty.

**Field Control Wiring** — 38AUM unit control voltage is 24 v. See Typical Wiring Schematic for typical field control connections and the unit's label diagram for field-supplied wiring details. Route control wires to the 38AUM unit through the opening in unit's end panel to the connections terminal board in the unit's control box. Remainder of the system controls connection will vary according to the specific construction details of the indoor section (air handler or packaged fan coil). Fig: - Typical Remote Thermostat Connection depict typical connections to a Carrier 40RUM fan coil unit. Plan for field connections carefully and install control wiring correctly per the project plan. Additional components and supplemental transformer accessory may be required. The 38AUM unit requires an external temperature control device. This device can be a thermostat (field-supplied) or a PremierLink controller (available as a field-installed accessory, for use on a Carrier Comfort Network or as a stand-alone control).

**Thermostat** — Install a Carrier-approved accessory thermostat according to installation instructions included with the accessory. Locate the thermostat accessory on a solid wall in the conditioned space to sense average temperature in accordance with the thermostat installation instructions.

The 38AUMZ is a single-circuit, two-stage cooling unit. Select a two—stage cooling thermostat, with or without supplemental heating as needed.

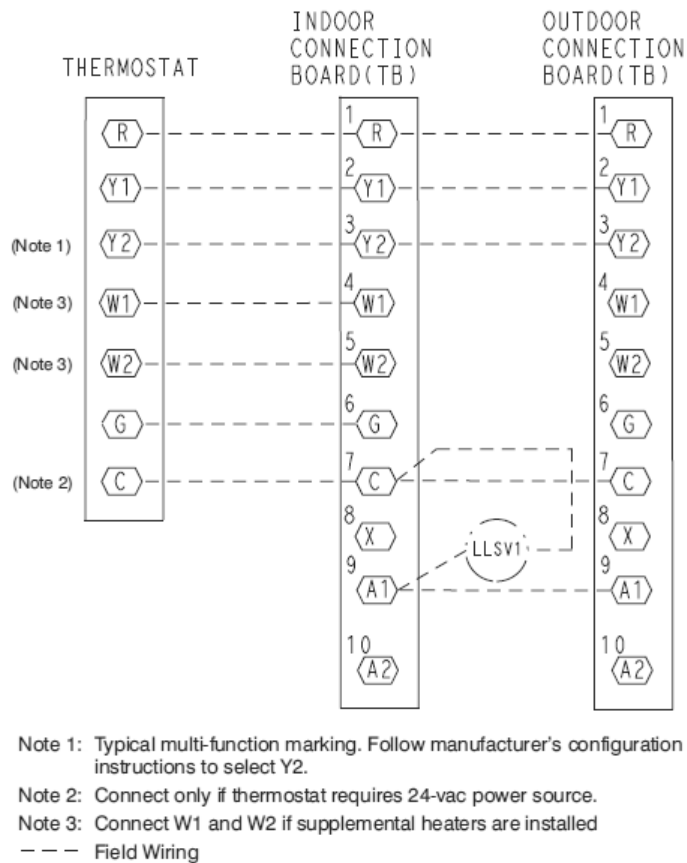

**Fig: - Typical Remote Thermostat Connections — 38AUMZ**



The 38AUMD is a dual-circuit, two-stage cooling unit. Select a two—stage cooling thermostat, with or without supplemental heating as needed.

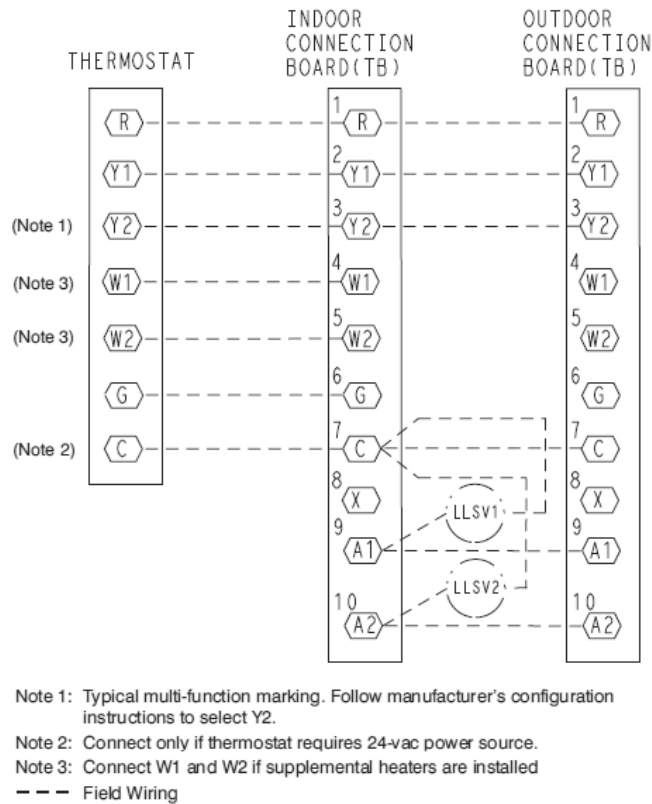
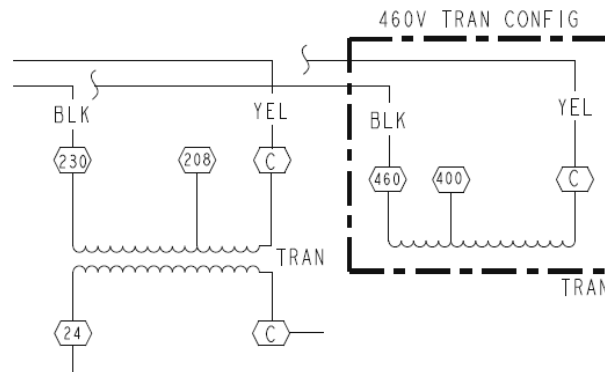

**Fig: - Typical Remote Thermostat Connections — 38AUMD**

Select a thermostat cable or equivalent single leads of different colors with minimum of five leads for 38AUMZ or six leads for 38AUMD unit. Check the thermostat installation instructions for additional features which might require additional conductors in the cable. For wire runs up to 50 ft. (15 m), use no. 18 AWG (American Wire Gage) insulated wire (35°C minimum). For 50 to 75 ft. (15 to 23 m), use no. 16 AWG insulated wire (35°C minimum). For over 75 ft. (23 m), use no. 14 AWG insulated wire (35°C minimum). All wire sizes larger than no. 18 AWG cannot be directly connected to the thermostat and will require a junction box and splice at the thermostat. PremierLink (accessory installation) – Refer to Form 33CS-58SI for details on connecting the PremierLink controller and its various sensors.

**Control Circuit Wiring** — Control voltage is 24 v. See Fig: - Power Wiring Connections and the unit's label diagram for field-supplied wiring details. Route control wires through the opening in unit's end panel to the connection in the unit's control box.

**Control Transformer Wiring** — On multi voltage units, check the transformer primary wiring connections. See Fig: - Control Transformer Wiring or refer to the unit's label diagram. If the unit will be operating at 208-3-60 power, remove the black wire (BLK) from the transformer primary connection labelled "230" and move it to the connection labelled "208".



**Fig: - Control Transformer Wiring**

## PRE-START-UP

**IMPORTANT:** Before beginning Pre-Start-Up or Start-Up, review Start-Up Checklist at the back of this book. The Checklist assures proper start-up of a unit and provides a record of unit condition, application requirements, system information, and operation at initial start-up.



### CAUTION

#### UNIT DAMAGE HAZARD

Failure to follow this caution may result in equipment damage.

Do not attempt to start the condensing unit, even momentarily, until the following steps have been completed. Compressor damage may result.

#### System Check

1. The electrical power source must agree with the unit's nameplate rating.
2. Check all air handler(s) and other equipment auxiliary components. Consult the manufacturer's instructions regarding any other equipment connected to the condensing unit. If the unit has field-installed accessories, be sure all are properly installed and correctly wired. If used, the airflow switch must be properly installed.
3. Check tightness of all electrical connections.
4. Be sure liquid line and low side of the system are properly leak checked and dehydrated.
5. Be sure the unit is properly charged. See "Preliminary Charge", below.
6. Open the liquid line and suction line service valves.
7. The crankcase heater must be firmly attached to the compressor crankcase. Be sure the crankcase is warm (heater must be on for 24 hours before starting compressor).

**Turn On Crankcase Heater** — *Turn on the crankcase heater for 24 hours before starting the unit to be sure all the refrigerant is out of the oil.* To energize the crankcase heater, proceed as follows:

1. Set the space thermostat set point above the space temperature so there is no demand for cooling.
2. Close the field disconnect.

**Preliminary Charge** — Before starting the unit, charge liquid refrigerant into the high side of the system through the liquid service valve. The amount of refrigerant added must be at least 80% of the operating charge listed in the Physical Data table. Allow high and low side pressures to equalize before starting compressor. If pressures do not equalize readily, charge vapor on low side of system to assure charge in the evaporator. Refer to GTAC II, Module 5, Charging, Recover, Recycling, and Reclamation for liquid charging procedures.



### CAUTION

#### UNIT DAMAGE HAZARD

Failure to follow this caution may result in equipment damage.

Prior to starting compressor, a preliminary charge of refrigerant must be added to avoid possible compressor damage.

# START-UP

**38AUM Units:** The compressor crankcase heater must be on for 24 hours before start-up. After the heater has been on for 24 hours, the unit can be started. If no time elapsed since the preliminary charge step was completed, it is unnecessary to wait the 24-hour period.

## Preliminary Checks

1. Check that electric power supply agrees with unit nameplate data.
2. Verify that the compressor crankcase heater is securely in place.
3. Check that the compressor crankcase heater has been on at least 24 hours.
4. Recheck for leaks using the procedure outlined in the Pre-Start-Up section, Leak Test and Dehydration. If any leaks are detected, repair as required. Evacuate and dehydrate as described in the Leak Test and Dehydration section.
5. Ensure that the preliminary charge has been added as described in the Pre-Start-Up section, Preliminary Charge.
6. All internal wiring connections must be tight, and all barriers and covers must be in place.

**Note:** The 38AUM units are factory charged with the required amount of oil. If recharging is required, use Emkarate RL 32-3MAF for the 38AUM units.

**Compressor Rotation** — On 3-phase units with scroll compressors, it is important to be certain that the compressor is rotating in the proper direction. 38AUM units are equipped with a Comfort Alert Diagnostic Module (CADM). Alert Code 7 indicates reverse power phasing.

## To correct phase order:

1. Turn off power to the unit, tag disconnect.
2. Reverse any two of the unit power leads.
3. Reapply power to the compressor, verify correct pressures.

## To verify the compressor is rotating in the proper direction:

1. Connect service gages to the suction and liquid pressure fittings.
2. Energize the compressor.
3. The suction pressure should drop and the liquid pressure should rise, as is normal on any start-up.

**Compressor Overload** — This overload interrupts power to the compressor when either the current or internal motor winding temperature becomes excessive, and automatically resets when the internal temperature drops to a safe level. This overload may require up to 60 minutes (or longer) to reset. If the internal overload is suspected of being open, disconnect the electrical power to the unit and check the circuit through the overload with an ohmmeter or continuity tester.

**Advanced Scroll Temperature Protection (ASTP)** — A label located above the terminal box identifies Copeland Scroll compressor models that contain this technology. See Fig: - Advanced Scroll Temperature Protection (ASTP) is a form of internal discharge temperature protection, that unloads the scroll compressor when the internal temperature reaches approximately 149°C (300°F). At this temperature, an internal bi-metal valve opens and causes the scroll elements to separate, which stops compression. Suction and discharge pressures balance while the motor continues to run. The longer the compressor runs unloaded, the longer it must cool before the bi-metal disk resets. See Fig: - Recommended Minimum Cool-Down Time After Compressor is Stopped.

To manually reset ASTP, the compressor should be stopped and allowed to cool. If the compressor is not stopped, the motor will run until the motor protector trips, which occurs up to 90 minutes later. Advanced Scroll Temperature Protection will reset automatically before the motor protector resets, which may take up to 2 hours.



**Fig: - Advanced Scroll Temperature Protection Label**

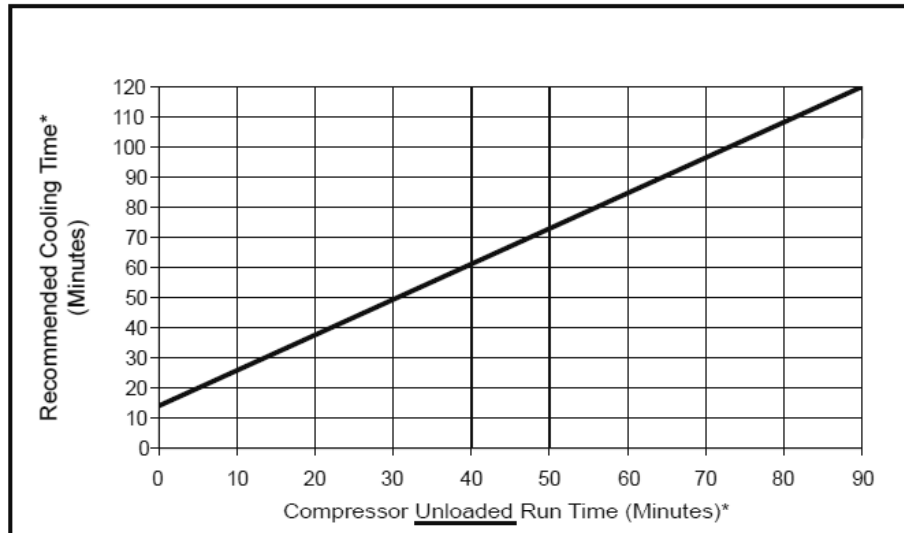

\*Times are approximate.

NOTE: Various factors, including high humidity, high ambient temperature, and the presence of a sound blanket will increase cool-down times.

Fig - Recommended Minimum Cool-Down Time After Compressor is Stopped

#### Start Unit

Set the space thermostat to a set point above space temperature so that there is no demand for cooling. Close the 38AUM disconnect switch. Only the crankcase heater will be energized.

Reset the space thermostat below ambient so that a call for cooling is ensured.



## CAUTION

### UNIT DAMAGE HAZARD

Failure to follow this caution may result in equipment damage.

Never charge liquid into the low-pressure side of system. Do not overcharge. During charging or removal of refrigerant, be sure indoor-fan system is operating. Ensure both outdoor fan motors are running; bypass any Motormaster function.

**Adjust Refrigerant Charge** — Refer to Cooling Charging Charts. For applications with line lengths greater than 125 ft (38 m), contact Carrier representative. Make sure that all condenser fans are operating, and on units with the HGBP (hot pass bypass) option make sure that the HGBP solenoid valve is deactivated (see procedure below), before adjusting charge to the charging charts. Vary refrigerant until the conditions of the chart are met. Note that the charging charts are different from the type normally used. The charts are based on charging the units to the correct subcooling for the various operating conditions. Accurate pressure gage and temperature sensing device are required. Connect the pressure gage to the service port on the liquid line service valve. Mount the temperature sensing device on the liquid line close to the liquid line service valve, and insulate it so that outdoor ambient temperature does not affect the reading. Indoor airflow must be within the unit's normal operating range. Operate the unit for a minimum of 15 minutes. Ensure that pressure and temperature readings have stabilized. Plot the liquid pressure and temperature on chart and add or reduce the charge to meet the curve. Adjust the charge to conform with the charging chart, using the liquid pressure and temperature to read the chart.

#### Using plotted operating point:

If plotted operating condition is -	Adjust charge by -
BELOW the curve	REDUCE charge
ABOVE the curve	ADD charge

#### Final Checks —

Ensure that all safety controls are operating, control panel covers are on, and the service panels are in place.

# OPERATING SEQUENCE

## Base Unit Controls

**Indoor (Supply) Fan**— The indoor fan contactor (IFC) is remotely located at the fan coil or fan section. If the thermostat fan operation is selected as Continuous, the IFC is energized and the indoor (supply) fan motor runs continuously. If the thermostat fan operation is selected as Automatic, the IFC will be energized on a call for Cooling; indoor (supply) fan motor runs. When thermostat call for Cooling is satisfied, the IFC is de-energized and indoor (supply) fan motor stops.

### Cooling Unit — 38AUMZ (Single Circuit)

On a thermostat call for Cooling, IFC will be energized and indoor (supply) fan motor runs. Thermostat output Y1 is energized; terminal Y1 at 38AUMZ unit receives 24-v. 24-v received at CADM1 terminal Y. If anti-recycle time delay period has not expired, CADM1 relay will remain open, de-energizing Solenoid Valve Relay (SVR) and preventing compressor start. When safety pressure switches are closed and CADM1 time delay expires, CADM1 relay closes, SVR and compressor contactor C1 are energized; liquid line solenoid valve LLSV opens, all outdoor fan motors start and Compressor 1 starts.

On a thermostat calling for Stage 2 Cooling, thermostat output Y2 is energized; terminal Y2 at 38AUMZ unit receives 24-v. 24-v received at CADM2 terminal Y. If anti-recycle time delay period has not expired, CADM2 relay will remain open, preventing Compressor 2 start. When safety pressure switches are closed and CADM2 time delay expires, CADM2 relay closes, compressor contactor C2 is energized; Compressor 2 starts.

As space cooling load is satisfied, thermostat outputs Y2 and Y1 are sequentially de-energized, removing 24-v at 38AUMZ terminals Y2 and Y1. Compressor 2 stops on Y2 opening. CADM2 begins its three-minute anti-recycle time delay. On Y1 opening, Compressor 1 stops, all outdoor fan motors stop and SVR relay is de-energized. Liquid line solenoid valve is de-energized and valve closes. CADM1 begins its three-minute anti-recycle time delay.

### Cooling Unit — 38AUMD (Two Circuit)

On a thermostat call for Cooling, IFC will be energized and indoor (supply) fan motor runs. Thermostat output Y1 is energized; terminal Y1 at 38AUMD unit receives 24-v. 24-v received at CADM1 terminal Y. If anti-recycle time delay period has not expired, CADM1 relay will remain open, de-energizing Solenoid Valve Relay 1 (SVR1) and preventing compressor start. When safety pressure switches are closed and CADM1 time delay expires, CADM1 relay closes, SVR1 and compressor contactor C1 are energized; liquid line solenoid valve LLSV1 opens, all outdoor fan motors start and Circuit 1 compressor starts.

On a thermostat calling for Stage 2 Cooling, thermostat output Y2 is energized; terminal Y2 at 38AUMD unit receives 24-v. 24-v received at CADM2 terminal Y. If anti-recycle time delay period has not expired, CADM2 relay will remain open, de-energizing Solenoid Valve Relay 2 (SVR2) and preventing compressor start. When safety pressure switches are closed and CADM2 time delay expires, CADM2 relay closes, SVR2 and compressor contactor C2 are energized; liquid line solenoid valve LLSV2 opens and Circuit 2 compressor starts.

As space cooling load is satisfied, thermostat outputs Y2 and Y1 are de-energized, removing 24-v at 38AUMD terminals Y2 and Y1. Circuit 2 compressor stops on Y2 opening; SVR2 is de-energized and LLSV2 closes. CADM2 begins its three-minute anti-recycle time delay. On Y1 opening, Circuit 1 compressor stops, all outdoor fan motors stop and SVR1 relay is de-energized. Liquid line solenoid valve LLSV1 is de-energized and valve closes. CADM1 begins its three-minute anti-recycle time delay.

## All Units

If either the Low Pressure Switch or High Pressure Switch opens while thermostat output Y1 or Y2 remain energized, the compressor contactor is de-energized, the compressor stops and liquid line solenoid is de-energized (valve closes). CADM initiates a TRIP event (cooling demand sensed at CADM terminal Y but no current is measured at T1, T2, T3 motor sensors); CADM relay opens and RED LED is illuminated. TRIP condition maintains lockout of compressor operation until CADM is manually reset. Reset CADM by cycling unit main power.

Complete system shutdown may be caused by loss of main power, open compressor internal overload, open low-pressure or high-pressure switch, or a fault detected by the CADM logic. Compressor operation without cooling may indicate the compressor's ASTP feature is active; disconnect unit power and allow compressor to cool. See Service section for further details.

**Heating** — Refer to fan coil unit installation instructions and accessory heating device installation instructions for operating sequences in heating mode.

# ROUTINE SYSTEM MAINTENANCE

These items should be part of a routine maintenance program, to be checked every month or two, until a specific schedule for each can be identified for this installation:

## Quarterly Inspection (and 30 days after initial start) — Indoor section

- Condenser coil cleanliness checked.
- Return air filter replacement
- Outdoor hood inlet filters cleaned
- Belt condition and tension checked
- Pulley alignment checked
- Fan shaft bearing locking collar tightness checked
- Condensate drain checked

**Seasonal Maintenance** — These items should be checked at the beginning of each season (or more often if local conditions and usage patterns dictate):

## Air Conditioning

- Condenser fan motor mounting bolts tightness
- Compressor mounting bolts
- Condenser fan blade positioning
- Control box cleanliness and wiring condition
- Wire terminal tightness
- Refrigerant charge level
- Evaporator coil cleaning
- Evaporator blower motor amperage

## Heating

- Power wire connections
- Fuses ready
- Manual-reset limit switch is closed

## Economizer or Outside Air Damper

- Inlet filters condition
- Check damper travel (economizer)
- Check gear and dampers for debris and dirt

# SERVICE

**Servicing Systems on Roofs With Synthetic Materials** — POE (polyolester) compressor lubricants are known to cause long term damage to some synthetic roofing materials. Exposure, even if immediately cleaned up, may cause embrittlement (leading to cracking) to occur in one year or more. When performing any service which may risk exposure of compressor oil to the roof, take appropriate precautions to protect roofing. Procedures which risk oil leakage include but are not limited to compressor replacement, repairing refrigerant leaks, replacing refrigerant components such as filter drier, pressure switch, metering device, coil, accumulator, or reversing valve.

## Synthetic Roof Precautionary Procedure:

1. Cover extended roof working area with an impermeable polyethylene (plastic) drop cloth or tarp. Cover an approximate 10 x 10 ft (3.3 x 3.3 m) area.
2. Cover area in front of the unit service panel with a terry cloth shop towel to absorb lubricant spills and prevent run-offs, and protect drop cloth from tears caused by tools or components.
3. Place terry cloth shop towel inside unit immediately under component(s) to be serviced and prevent lubricant run-offs through the louvered openings in the base pan.
4. Perform required service.
5. Remove and dispose of any oil contaminated material per local codes.

**Liquid Line Filter Drier** — The factory-provided filter drier is specifically designed to operate with Puron®. Replace the filter drier with factory-authorized components only with a filter drier with desiccant made from 100% molecular sieve grade XH-11. Filter drier must be replaced whenever the refrigerant system is opened.

When removing a filter drier, use a tubing cutter to cut the drier from the system. **Do not unsweat a filter drier** from the system. Heat from unsweating will release moisture and contaminants from drier into system.

**CAUTION**

**EQUIPMENT DAMAGE HAZARD**

Failure to follow this caution may result in equipment damage.

This system uses Puron® refrigerant which has higher pressures than R-22 and other refrigerants. No other refrigerant may be used in this system. Gage set, hoses, and recovery system must be designed to handle Puron. If you are unsure consult the equipment manufacturer.

**Compressor Oil**

**CAUTION**

**EQUIPMENT DAMAGE HAZARD**

Failure to follow this caution may result in equipment damage.

The compressor in a Puron system uses a Polyolester (POE) oil. This oil is extremely hygroscopic, meaning it absorbs water readily. POE oils can absorb 15 times as much water as other oils designed for HCFC and CFC refrigerants. Take all necessary precautions to avoid exposure of the oil to the atmosphere.

**Field Refrigerant Access Ports** — Field service access to refrigerant pressures is through the access ports located at the service valves. These ports are 1/4-in SAE Flare couplings with Schrader check valves and service caps. Use these ports to admit nitrogen to the field tubing during brazing, to evacuate the tubing and evaporator coil, to admit initial refrigerant charge into the low-side of the system and when checking and adjusting the system refrigerant charge. When service activities are completed, ensure the service caps are in place and secure; check for leaks. If the Schrader check valve must be removed and re-installed, tighten to 2-3 in-lbs (23-34 N-cm).

**Factory High-Flow Access Ports** — There are two additional access ports in the system – on the suction tube between the compressor and the suction service valve and on the liquid tube near the liquid service valve. These are brass fittings with black plastic caps. The hose connection fittings are standard 1/4-in SAE Male Flare couplings. The brass fittings are two-piece High Flow valves, with a receptacle base brazed to the tubing and an integral spring-closed check valve core screwed into the base. (See Fig. 35) This check valve is permanently assembled into this core body and cannot be serviced separately; replace the entire core body if necessary. Service tools are available from RCD that allow the replacement of the check valve core without having to recover the entire system refrigerant charge. Apply compressor refrigerant oil to the check valve core's bottom o-ring. Install the fitting body with 96 ±10 in-lbs (1085 ±23 N-cm) of torque; do not overtighten.

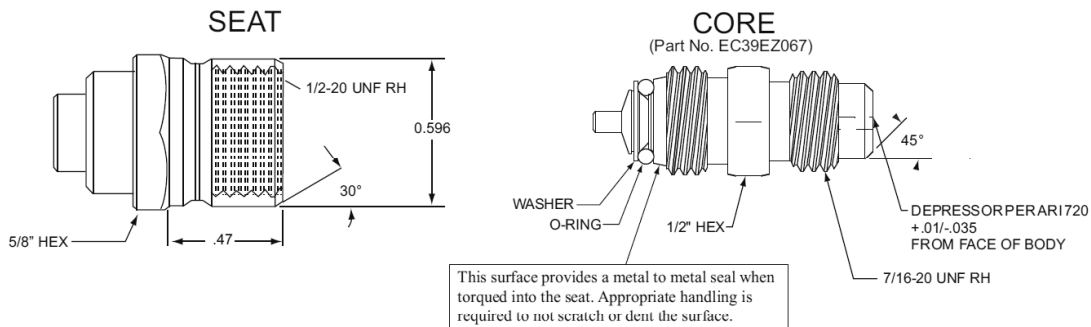

**Fig. 35 - CoreMax Access Port Assembly**

## Comfort Alert Diagnostic Module

The Comfort Alert Diagnostic Module (CADM) monitors and analyzes data from the Copeland Scroll® three-phase compressor and the thermostat demand. The CADM also provides a 3-minute anti-recycle time delay to compressor cycling. Each compressor has a separate CADM module.

The CADM detects causes for electrical and system related failures without any sensors. Flashing LEDs communicate the Alert codes to guide service technicians in accurately and quickly troubleshooting the system and determining root cause for the failure.

Inputs to the CADM include 24-vac power, thermostat Y1 or Y2, compressor contactor coil (common side) and compressor power leads (from the compressor contactor).

Input	Terminal	Voltage
Control Power	R	24-V
Control Common	C	24-V
Cooling	Y	24-V
Contacting Coil	P	24-V
Line A	T1	Line
Line B	T2	Line
Line C	T3	Line

Control of the compressor contactor coil is through a normally-closed (power on the module) contact between terminals P and C.

Communications of status and alert conditions is through three LEDs located on the top edge of the module housing (see Fig:- CADM Housing/LED Locations): POWER (green), ALERT (yellow), and TRIP (red).

The POWER LED indicates the presence of control power to the CADM.

The ALERT LED indicates an abnormal condition exists in the system through a flash code. The ALERT LED will blink a number of times consecutively, pause and then repeat the process. The number of blinks, defined in Table LED Status Codes, correlates to a particular abnormal condition; troubleshooting tips are provided for each Alert code. Reset of the ALERT may be automatic or manual. If the fault condition causing the Alert is self-corrected, the Alert code will be removed and the CADM will automatically reset and allow the system to restart normally. Manual reset requires that main power to the 38AU unit be recycled after the cause for the Alert condition has been detected and corrected.

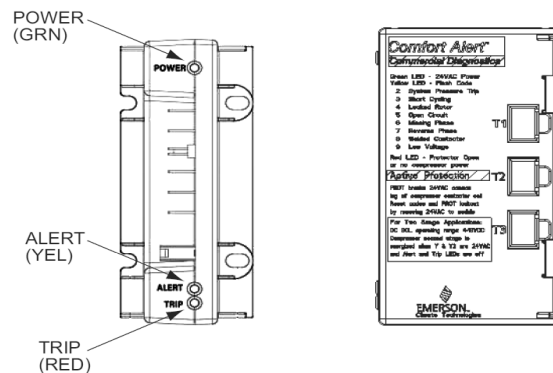

**Fig:- CADM Housing/LED Locations**

The TRIP LED indicates either a time-delay period is currently active (RED LED is blinking) or the module has locked out the compressor (RED LED is on steady). A lockout condition will occur when the CADM detects a thermostat demand at input Y but there is no power at the compressor line terminals T1 or T2 or T3. This lockout can occur due to a safety switch (LPS or HPS) opening and de-energizing the compressor contactor, the compressor-motor internal overload opens, or other internal power interruption has occurred. Reset of the TRIP LED requires that unit main power be recycled after the loss of power to the compressor condition has been detected and corrected.

Simultaneous Blinking of YELLOW and RED LEDs indicates control power input to the CADM is low. Check control circuit transformer and wiring.

Troubleshooting the CADM Wiring – Flashing LEDs also indicate wiring problems to the CADM. See Table – CADM Troubleshooting for discussion of additional LED flash codes and troubleshooting instructions.



**Table - LED Status Codes**

Status LED	Status LED Description	Status LED Troubleshooting Information
Green "POWER"	Module has power	Supply voltage is present at module terminals
Red "TRIP" LED On Solid	Thermostat demand signal Y is present, but the compressor is not running.	<ol style="list-style-type: none"> <li>1. Compressor protector is open</li> <li>2. Condensing unit power disconnect is open</li> <li>3. Compressor circuit breaker or fuse(s) is open</li> <li>4. Broken supply wires or connector is not making contact</li> <li>5. Compressor power wires not routed through Comfort Alert</li> <li>6. Compressor contactor has failed open</li> </ol>
Red "TRIP" LED Flashing	The anti-short cycle timer (3 minutes) in module is preventing compressor restart.	
Module locks out compressor when compressor damaging ALERT code appears. Lockout ALERT codes are noted in the Status LED Description. During a compressor lock out, 24VAC power must be removed from module to manually reset.		
Yellow "ALERT" LED On Solid	A short circuit or over current condition exists on PROT terminal.	<ol style="list-style-type: none"> <li>1. Compressor contactor coil shorted</li> <li>2. Electrical load too high for PROT circuit (maximum 1 Amp)</li> <li>3. 24 V AC wired directly to PROT terminal</li> </ol>
Yellow "ALERT" Flash Code 2	System Pressure Trip Discharge pressure out of limits LOCKOUT	<ol style="list-style-type: none"> <li>1. High head pressure</li> <li>2. Condenser coil poor air circulation (dirty, blocked, damaged)</li> <li>3. Condenser fan is not running</li> <li>4. If low pressure switch is open:                             <ol style="list-style-type: none"> <li>a. Low refrigerant charge</li> <li>b. Evaporator blower is not running</li> <li>c. Evaporator coil is frozen</li> <li>d. Faulty metering device</li> <li>e. Condenser coil is dirty</li> <li>f. Liquid line restriction (filter drier blocked if present)</li> </ol> </li> </ol>
Yellow "ALERT" Flash Code 3	Short Cycling Compressor is running only briefly (four consecutive cycles of less than three minutes each) LOCKOUT	<ol style="list-style-type: none"> <li>1. Loose connection between thermostat Y1 and CADM Y terminal.</li> <li>2. Unit short – cycling on thermostat</li> <li>3. System or control board defective</li> </ol>
Yellow "ALERT" Flash Code 4	Locked Rotor LOCKOUT	<ol style="list-style-type: none"> <li>1. Low line voltage to compressor</li> <li>2. Excessive liquid refrigerant in compressor</li> <li>3. Compressor bearings are seized</li> </ol>
Yellow "ALERT" Flash Code 5	Open Circuit	<ol style="list-style-type: none"> <li>1. Condensing unit power disconnect is open</li> <li>2. Compressor circuit breaker or fuses are open</li> <li>3. Compressor contactor has failed open</li> <li>4. High pressure switch is open and requires manual reset</li> <li>5. Broken supply wires or connector is not making contact</li> <li>6. Unusually long compressor protector reset time due to extreme ambient temperature</li> <li>7. Compressor windings are damaged</li> </ol>
Yellow "ALERT" Flash Code 6	Missing Phase LOCKOUT	<ol style="list-style-type: none"> <li>1. Compressor fuse is open on one phase</li> <li>2. Broken wire or connector on one phase</li> <li>3. Compressor motor winding is damaged</li> <li>4. Utility supply has dropped one phase</li> </ol>
Yellow "ALERT" Flash Code 7	Reverse Phase LOCKOUT	<ol style="list-style-type: none"> <li>1. Compressor running backward due to supply phase reversal</li> </ol>
Yellow "ALERT" Flash Code 8	Welded Contactor Compressor always runs	<ol style="list-style-type: none"> <li>1. Compressor contactor has failed closed</li> <li>2. Thermostat demand signal not connected to module</li> </ol>
Yellow "ALERT" Flash Code 9	Low Voltage Control circuit < 18VAC	<ol style="list-style-type: none"> <li>1. Control circuit transformer is overloaded</li> <li>2. Low line voltage to compressor</li> </ol>

**Table – CADM Troubleshooting**

Miswired Module Indication	Recommended Troubleshooting Action
Green LED is not on, module does not power up	Determine if both R and C module terminals are connected. Verify voltage is present at module's R and C terminals. <b>NOTE:</b> The CADM requires a constant nominal 24VAC power supply. The wiring to the module's R and C terminals must be directly from the control transformer. The module cannot receive its power from another device that will interrupt the 24VAC power supply. See the 38AU Wiring Diagram(s) (Fig. 30 and Fig. 31).
Green LED Intermittent, module powers up only when compressor runs	Determine if R and Y terminals are wired in reverse. Verify module's R and C terminals have a constant source. See <b>"NOTE"</b> above for details on R and C wiring.
TRIP LED is on but system and compressor check OK	Verify Y terminal is wired properly per the 38AU wiring diagram (see Fig. 30 and Fig. 31). Verify voltage at contactor coil falls below 0.5VAC when off. Verify 24VAC is present across Y and C when thermostat demand signal is present. If not, R and C are reverse wired.
TRIP LED and ALERT LED flashing together	Verify R and C terminals are supplied with 19-28VAC.
ALERT Flash Code 3 (Compressor Short Cycling) displayed incorrectly	Verify Y terminal is connected to 24VAC at contactor coil. Verify voltage at contactor coil falls below 0.5VAC when off.
ALERT Flash Code 5 or 6 (Open Circuit, Missing Phase) displayed incorrectly	Check that compressor T1 and T3 wires are through module's current sensing holes. Verify Y terminal is connected to 24VAC at contactor coil. Verify voltage at contactor coil falls below 0.5VAC when off.
Alert Flash Code * (Welded Contactor) displayed incorrectly	Determine if module's Y terminal is connected. Verify Y terminal is connected to 24VAC at contactor coil. Verify 24VAC is present across Y and C when thermostat demand signal is present. If not, R and C are reverse wired. Verify voltage at contactor coil falls below 0.5VAC when off.

## Compressor Protection

**Compressor Overtemperature Protection (IP)** — A thermostat installed on the compressor motor winding reacts to excessively high winding temperatures and shuts off the compressor.

**Crankcase Heater** — The heater minimizes absorption of liquid refrigerant by oil in the crankcase during brief or extended shutdown periods. The heater is wired to cycle with the compressor; the heater is off when compressor is running, and on when compressor is off. The crankcase heater will operate as long as the power circuit is energized. The main disconnect must be on to energize the crankcase heater.

**IMPORTANT:** Never open any switch or disconnect that energizes the crankcase heater unless unit is being serviced or is to be shut down for a prolonged period. After a prolonged shutdown on a service job, energize the crankcase heater for 24 hours before starting the compressor.

**Advanced Scroll Temperature Protection (ASTP)** — See "Advanced Scroll Temperature Protection (ASTP)"

**Low-Pressure Switch** — The 38AUM low-pressure switch is stem-mounted on the suction line. Switches are all fixed, non-adjustable type.

**High-Pressure Switch** — The high-pressure switch is stem mounted on the discharge line. The switch is a fixed, non-adjustable type.

**Outdoor Fans** — Each fan is supported by a formed-wire mount bolted to the fan deck and covered with a wire guard. Fan motors have permanently lubricated bearings.

1. Shut off unit power supply. Install lockout tag.
2. Remove outdoor fan assembly (grille, motor, and fan).
3. Loosen fan hub setscrews.
4. Adjust fan height.
5. Tighten setscrews to 84 in-lbs (949 N-cm).
6. Replace outdoor fan assembly.

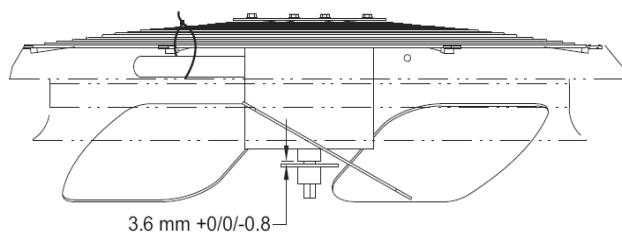

**Fig: - Outdoor Fan Blade Position**

**Lubrication — Fan Motors:** The fan motors have sealed bearings. No provisions are made for lubrication.

**Compressor:** The compressor has its own oil supply. Loss of oil due to a leak in the system should be the only reason for adding oil after the system has been in operation.

### Coil Type Identification

38AUM units are available with different coil types. Cleaning methods differ for each type so identifying the coil type is important. Unit model number and appearance can identify the coil type.

**Round--Tube Plate--Fin (RTPF) Type —** This construction uses a series of small diameter copper hairpin tubes running horizontally with vertical plate fins. The plate fins may be aluminum (standard) or copper (optional). Various optional coatings are also available. These coils are segmented two-row designs.

Periodic cleaning with Totaline® environmentally sound coil cleaner is essential to extend the life of RTPF coils. This cleaner is available from Carrier Replacement parts division as part number P902-0301 for a one gallon container, and part number P902-0305 for a 5 gallon container. It is recommended that all RTPF coils be cleaned with the Totaline environmentally sound coil cleaner as described below.

**Note:** Coil cleaning should be part of the unit's regularly scheduled maintenance procedures to ensure long life of the coil. Failure to clean the coils may result in reduced durability in the environment.

Avoid the use of:

- Coil brighteners
- Acid cleaning prior to painting
- High pressure washers
- Poor quality water for cleaning

Totaline environmentally sound coil cleaner is non-flammable, hypoallergenic, non-bacterial, and a USDA accepted biodegradable agent that will not harm the coil or surrounding components such as electrical wiring, painted metal surfaces, or insulation. Use of non-recommended coil cleaners is strongly discouraged since coil and unit durability could be affected.

### Totaline Environmentally Sound Coil Cleaner Application Equipment —

- 2 1/2 gallon garden sprayer
- Water rinse with low velocity spray nozzle



## CAUTION

### EQUIPMENT DAMAGE HAZARD

Failure to follow this caution may result in corrosion and damage to the unit.

Harsh chemicals, household bleach or acid or basic cleaners should not be used to clean outdoor or indoor coils or any kind. These cleaners can be very difficult to rinse out of the coil and can accelerate corrosion at the fin/tube interface where dissimilar materials are in contact. If there is dirt below the surface of the coil use the Totaline environmentally sound coil cleaner as described above.



## CAUTION

### EQUIPMENT DAMAGE HAZARD

Failure to follow this caution may result in reduced unit performance.

High velocity water from a pressure washer, garden hose, or compressed air should never be used to clean a coil. The force of the water or air jet will bend the fin edges and increase airside pressure drop.

**Totaline Environmentally Sound Coil Cleaner Application Instructions:**

**Note:** Proper eye protection such as safety glasses is recommended during mixing and application.

1. Turn off unit power.
2. Remove screws holding rear corner post and top cover in place. Pivot top cover up 12 to 18 inches (305 to 457 mm) and support with a rigid support. See Fig. 47.
3. Remove all surface loaded fibers and dirt with a vacuum cleaner. If a vacuum cleaner is not available, a soft non-metallic bristle brush may be used. In either case, the tool should be applied in the direction of the fins. Coil surfaces can be easily damaged (fin edges can be easily bent over and damage to the coating of a protected coil) if the tool is applied across the fins.

**Note:** Use of a water stream, such as a garden hose, against surface loaded coil will drive the fibers and dirt into the coil, making cleaning efforts more difficult. Surface loaded fibers must be completely removed prior to using low velocity clean water rinse.

4. Using a low velocity garden hose thoroughly wet finned surfaces with clean water. Be careful not to bend the fins.
5. Mix Totaline environmentally sound coil cleaner in a 2 1/2 gallon garden sprayer according to the instructions included with the cleaner. The optimum solution temperature is 100°F (38°C).

**Note:** Do NOT USE water in excess of 130°F (54°C), as the enzymatic activity will be destroyed.

6. Thoroughly apply Totaline® environmentally sound coil cleaner solution to all coil surfaces including the finned area, tube sheets and coil headers.
7. Hold garden sprayer nozzle close to finned areas and apply cleaner with a vertical, up-and-down motion. Avoid spraying in horizontal pattern to minimize potential for fin damage.
8. Ensure cleaner thoroughly penetrates deep into finned areas.
9. Interior and exterior finned areas must be thoroughly cleaned.
10. Finned surfaces should remain wet with cleaning solution for 10 minutes.
11. Ensure surfaces are not allowed to dry before rinsing. Reapply cleaner as needed to ensure 10-minute saturation is achieved.
12. Thoroughly rinse all surfaces with low velocity clean water using downward rinsing motion of water spray nozzle. Protect fins from damage from the spray nozzle.
13. Replace top cover and rear corner posts.

# PIPING RECOMMENDATION

## 38AUMZ07-08 PIPING RECOMMENDATION (SINGLE CIRCUIT UNIT)

Model	Equivalent Length					
	Ft	0-38	38-75	75-113	113-150	150-188
	m	0-12	12-23	23-34	34-46	46-57
	Linear Length					
	Ft	0-25	25-50	50-75	75-100	100-125
	m	0-8	8-15	15-23	23-30	30-38
38AUMZ07	Liquid Line	3/8	3/8	3/8	3/8	3/8
	Max Lift (ft)	25	50	75	100	125
	Suction Line	1 1/8	1 1/8	1 1/8	1 1/8	1 1/8
	Charge (lbs)	13.7	14.8	16.8	18.9	20.6
38AUMZ08	Liquid Line	1/2	1/2	1/2	1/2	1/2
	Max Lift (ft)	25	50	75	100	93
	Suction Line	1 1/8	1 1/8	1 1/8	1 1/8	1 1/8
	Charge (lbs)	13.7	14.8	16.8	18.9	20.6

## 38AUMD12-16 PIPING RECOMMENDATION (DUAL CIRCUIT UNIT)

Model	Equivalent Length					
	Ft	0-38	38-75	75-113	113-150	150-188
	m	0-12	12-23	23-34	34-46	46-57
	Linear Length					
	Ft	0-25	25-50	50-75	75-100	100-125
	m	0-8	8-15	15-23	23-30	30-38
38AUMD12	Liquid Line	3/8	3/8	3/8	3/8	3/8
	Max Lift (ft)	25	50	75	83	62
	Suction Line	1 1/8	1 1/8	1 1/8	1 1/8	1 1/8
	Charge (lbs)	11.7/11.7	12.7/12.7	14.2/14.2	15.3/15.3	16.5/16.5
38AUMD14	Liquid Line	1/2	1/2	1/2	1/2	1/2
	Max Lift (ft)	25	50	75	54	45
	Suction Line	1 1/8	1 1/8	1 1/8	1 1/8	1 1/8
	Charge (lbs)	15.4/16.3	16.4/17.3	20.2/21.1	19/19.9	20.2/21.1
38AUMD16	Liquid Line	1/2	1/2	1/2	1/2	1/2
	Max Lift (ft)	25	50	75	54	45
	Suction Line	1 1/8	1 1/8	1 1/8	1 1/8	1 1/8
	Charge (lbs)	20.9/19.3	21.9/20.3	25.7/24.1	24.5/22.9	25.7/24.1

### Legend:

Equivalent: Length Equivalent tubing length, including effects of refrigeration specialties devices

Linear Length: Linear tubing length, feet

Liquid Line: Tubing size, inches OD.

Max Lift:

Maximum liquid lift (indoor unit ABOVE outdoor unit only), at maximum permitted liquid line pressure drop:

- Linear Length Less than 75 ft (23 m): Minimum 2.0° F subcooling entering TXV
- Linear Length Greater than 75 ft (23m): Minimum 0.5° F subcooling entering TXV

Suction Line: Tube size, inches OD

Charge Charge Quantity, lbs. Calculated for both liquid line sizes (where applicable), but only with larger suction line size (where applicable)

DNU Do Not Use (pressure drop exceeds available subcooling in this model)

NOTE: For applications with equivalent length greater than 188 ft (57 m) and/or linear length greater than 125 ft (38 m), contact your local Carrier representative.

# ELECTRICAL DATA TABLE

## 230V-3Ph-60Hz

Unit	Voltage Range		COMP 1		COMP 2		OFM (ea)		Power Supply	
	Min	Max	RLA	LRA	RLA	LRA	HP	FLA	MCA	MOCP
38AUMZ07	207	253	19.0	123	-	-	1/4	1.42	26.6	50
38AUMZ08	207	253	25.0	164	-	-	1/4	1.42	34.1	50
38AUMD12	207	253	15.9	110	15.9	110	1/4	1.42	38.6	50
38AUMD14	207	253	22.4	149	22.4	149	1/4	1.42	53.2	75
38AUMD16	207	253	25.0	164	25.0	164	1/2	3.6	63.5	80

## 400V-3Ph-60Hz

Unit	Voltage Range		COMP 1		COMP 2		OFM (ea)		Power Supply	
	Min	Max	RLA	LRA	RLA	LRA	HP	FLA	MCA	MOCP
38AUMZ07	360	440	10.7	78	-	-	1/4	1.42	16.2	25
38AUMZ08	360	440	13.9	94	-	-	1/4	1.42	20.2	30
38AUMD12	360	440	8.5	66	8.5	66	1/4	1.42	21.9	30
38AUMD14	360	440	10.9	88	10.9	88	1/4	1.42	27.4	35
38AUMD16	360	440	13.9	94.3	13.9	94.3	1/2	3.6	38.5	50

## 460V-3Ph-60Hz

Unit	Voltage Range		COMP 1		COMP 2		OFM (ea)		Power Supply	
	Min	Max	RLA	LRA	RLA	LRA	HP	FLA	MCA	MOCP
38AUMZ07	414	506	9.7	62	-	-	1/4	0.7	13.6	20
38AUMZ08	414	506	12.2	100	-	-	1/4	0.7	16.7	25
38AUMD12	414	506	7.76	52	7.76	52	1/4	0.7	18.9	25
38AUMD14	414	506	10.6	75	10.6	75	1/4	0.7	25.3	35
38AUMD16	414	506	12.2	100	12.2	100	1/2	1.9	31.3	40

### Legend and Notes for Electrical Data Table

- FLA** - Full Load Amps
- IFM** - Indoor (Evaporator) Fan Motor
- LRA** - Locked Rotor Amps
- MCA** - Minimum Circuit Amps
- MOCP** - Maximum Overcurrent Protection
- Application heater kW (Using multiplication factor table in Electric Resistance Heater Data Table)
- NEC** - National Electrical Code
- OFM** - Outdoor (Condenser) Fan Motor
- RLA** - Rated Load Amps
- HACR** - Heating, Air-Conditioning and Refrigeration
- ◊ Fuse or HACR Circuit Breaker

### Unbalanced 3-Phase Supply Voltage

*Never operate a motor where phase imbalance in supply voltage is greater than 2%.*

Use the following formula to determine the percentage of voltage imbalance

$$= 100 \times \frac{\text{Maximum Deviation From Average Voltage}}{\text{Average Voltage}}$$

Example: Supply Voltage is 400V - 3ph - 60Hz

AB = 392v	Average Voltage = $\frac{392 + 404 + 395}{3}$
BC = 404v	
AC = 395v	$= \frac{1191}{3} = 397V$

Determine maximum deviation from average voltage

$$(AB) 397 - 392 = 5v$$

$$(BC) 404 - 397 = 7v$$

$$(AC) 457 - 397 = 2v$$

Maximum Deviation is 7v.

Determine Percentage Voltage Imbalance.

$$\% \text{ Voltage Imbalance} = 100 \times \frac{7}{397} = 1.76\%$$

This amount of phase imbalance is satisfactory as it is below the maximum allowable 2%

**IMPORTANT:** If the supply voltage phase imbalance is more than 2% contact your local electric utility company

# TYPICAL WIRING SCHEMATIC – 38AUMZ07/08 – 230V-3Ph-60Hz

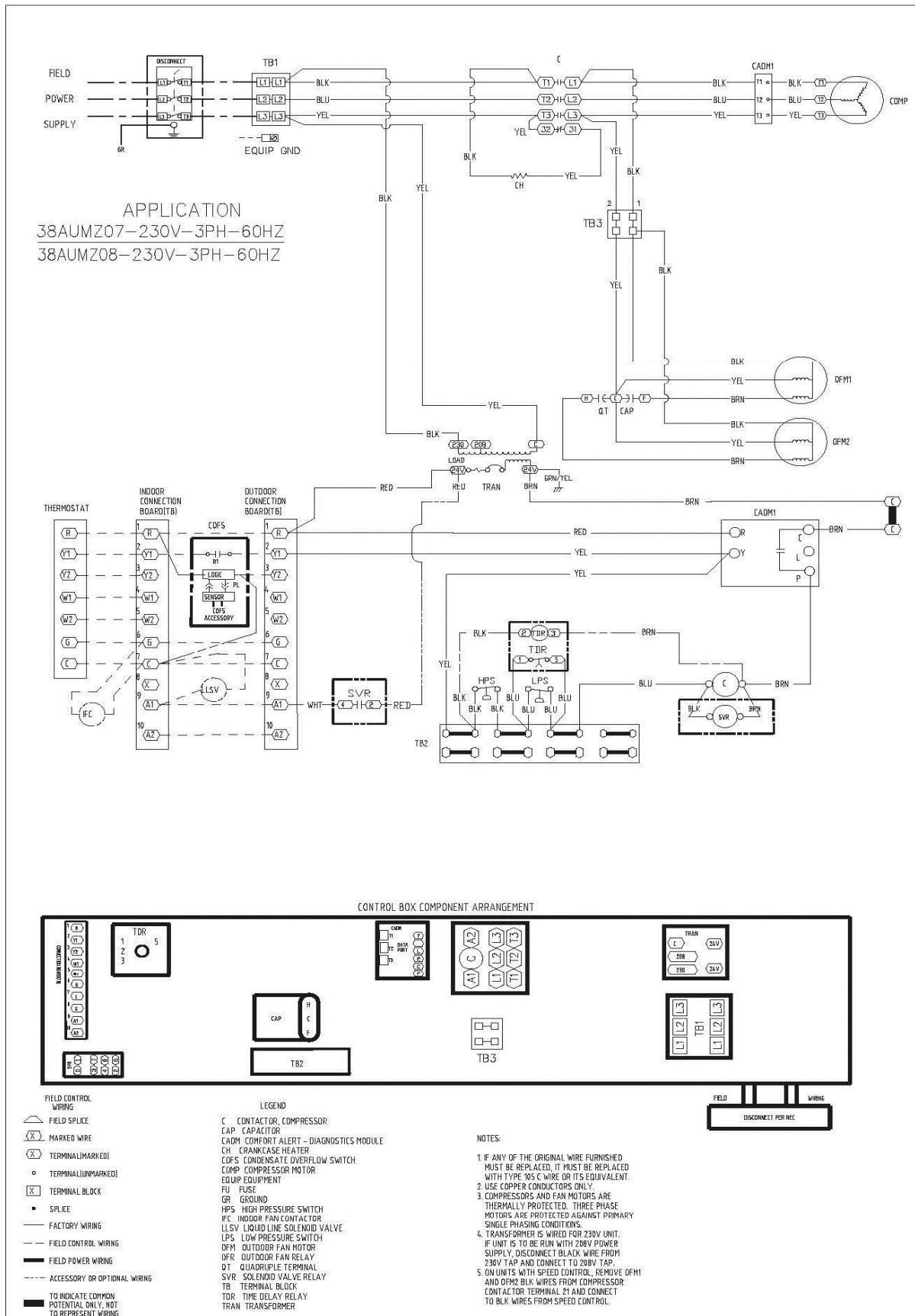

# TYPICAL WIRING SCHEMATIC – 38AUMD12/14/16 – 230V-3Ph-60Hz

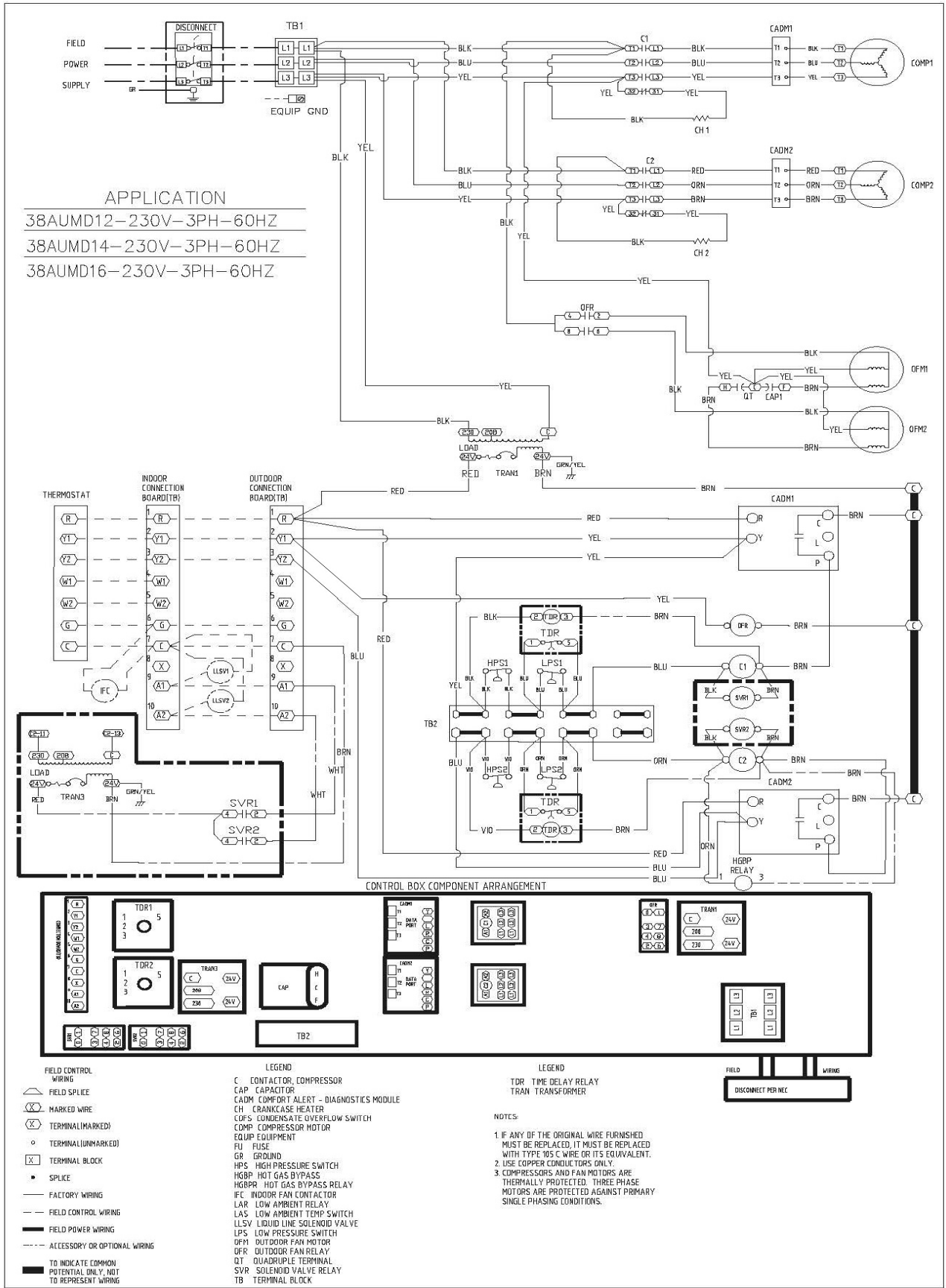



# TYPICAL WIRING SCHEMATIC – 38AUMZ07/08 – 400V-3Ph-60Hz

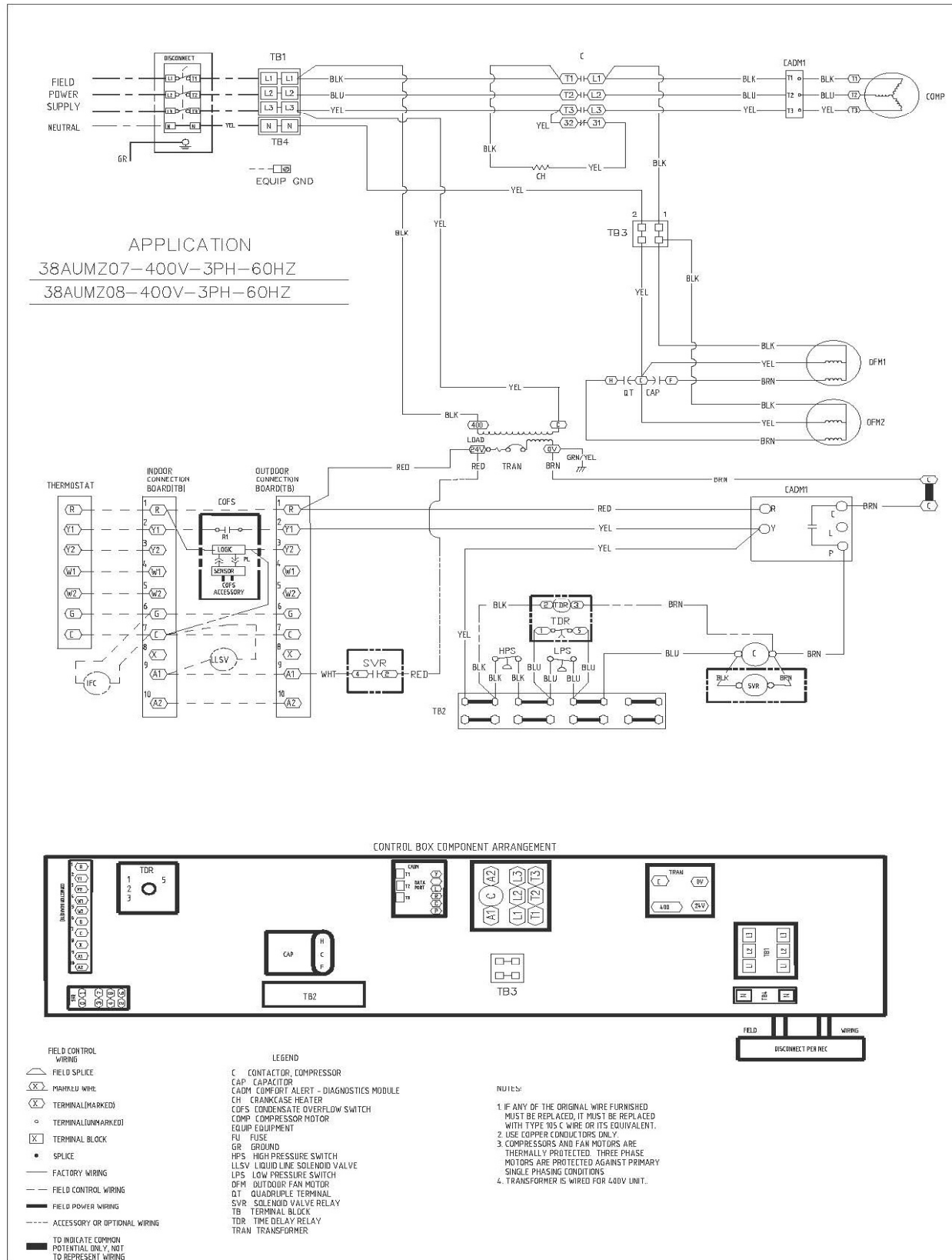

# TYPICAL WIRING SCHEMATIC – 38AUMD12/14/16 – 400V-3Ph-60Hz

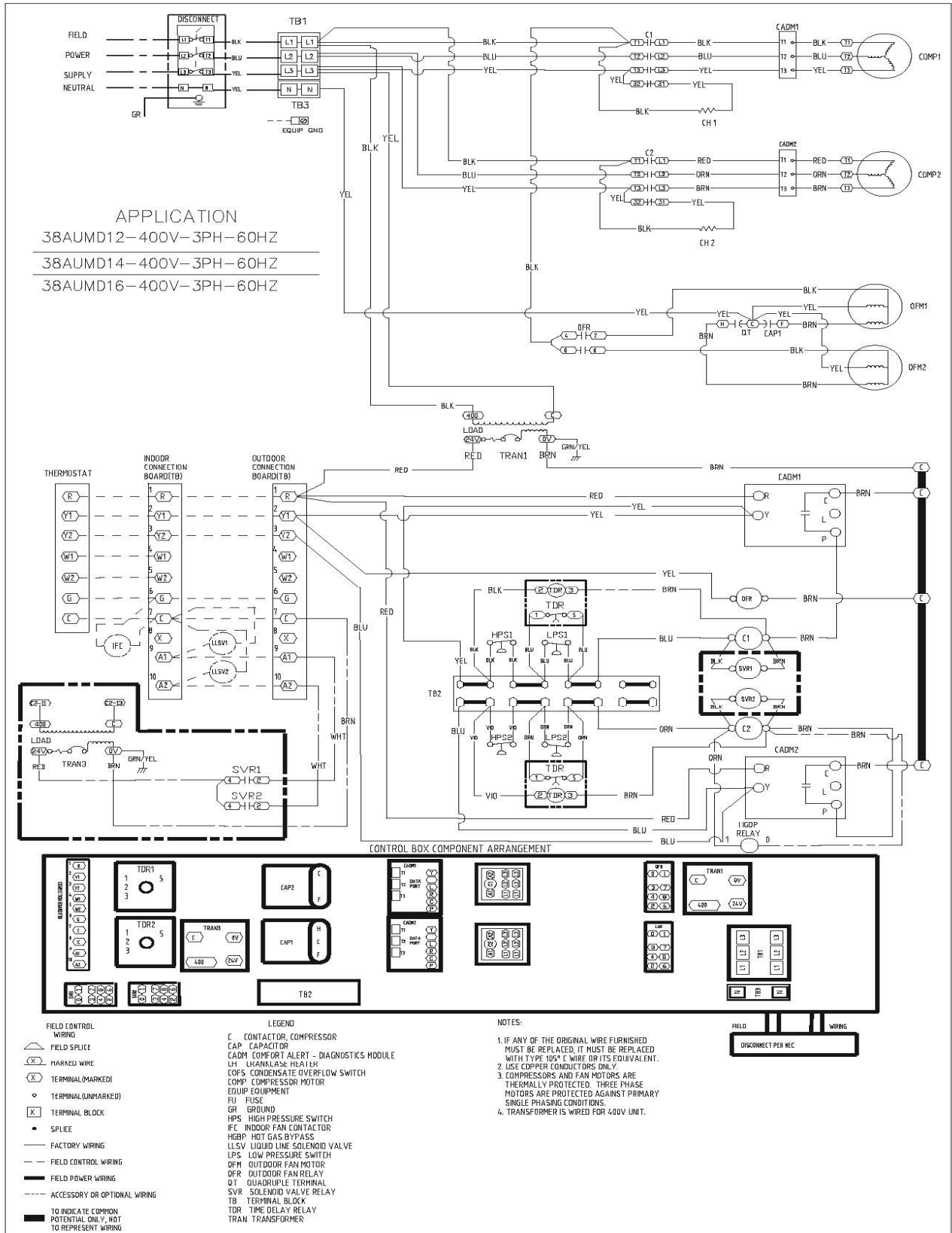

# TYPICAL WIRING SCHEMATIC – 38AUMZ07/08 – 460V-3Ph-60Hz

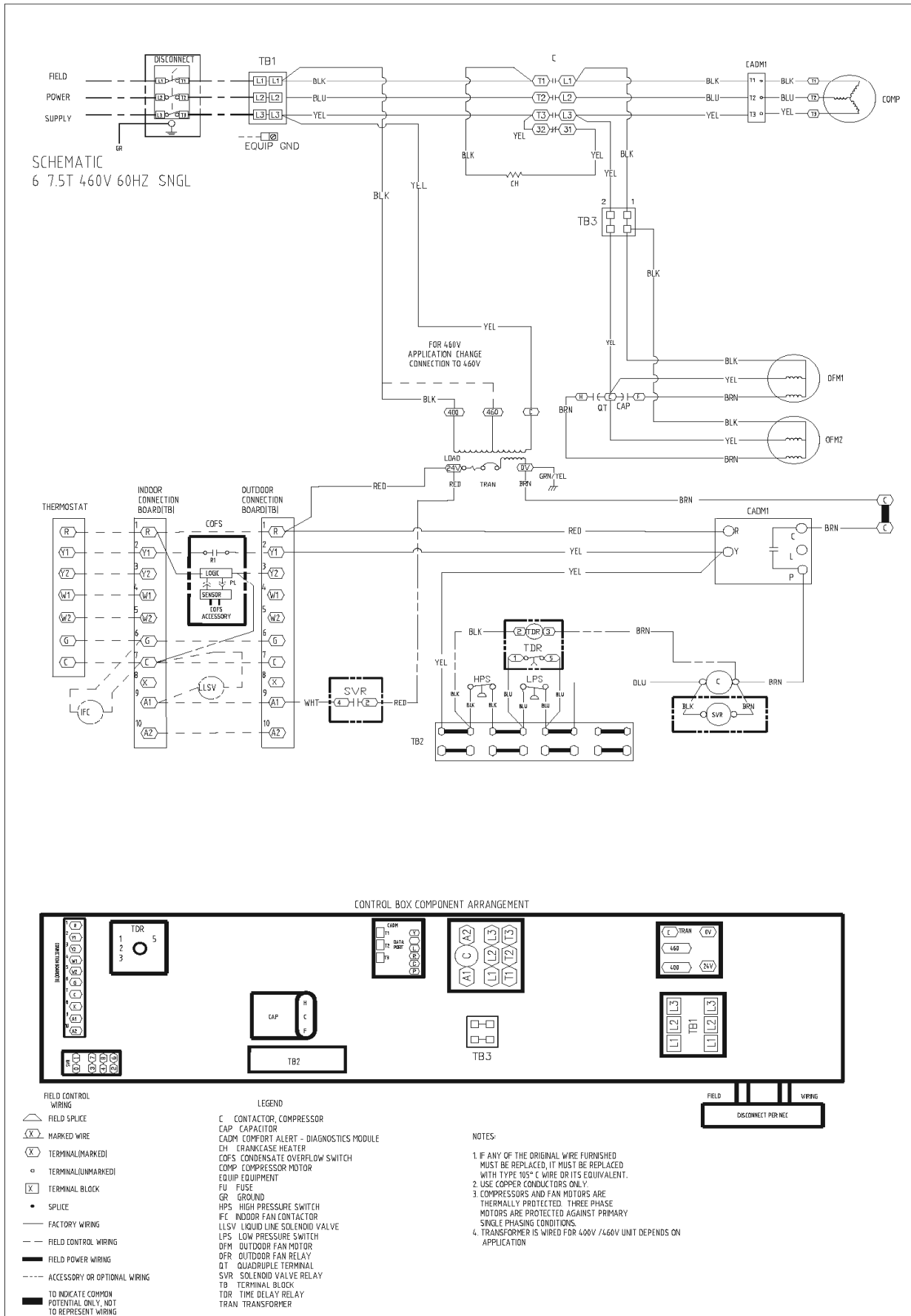

# TYPICAL WIRING SCHEMATIC – 38AUMD12/14/16 – 460V-3Ph-60Hz

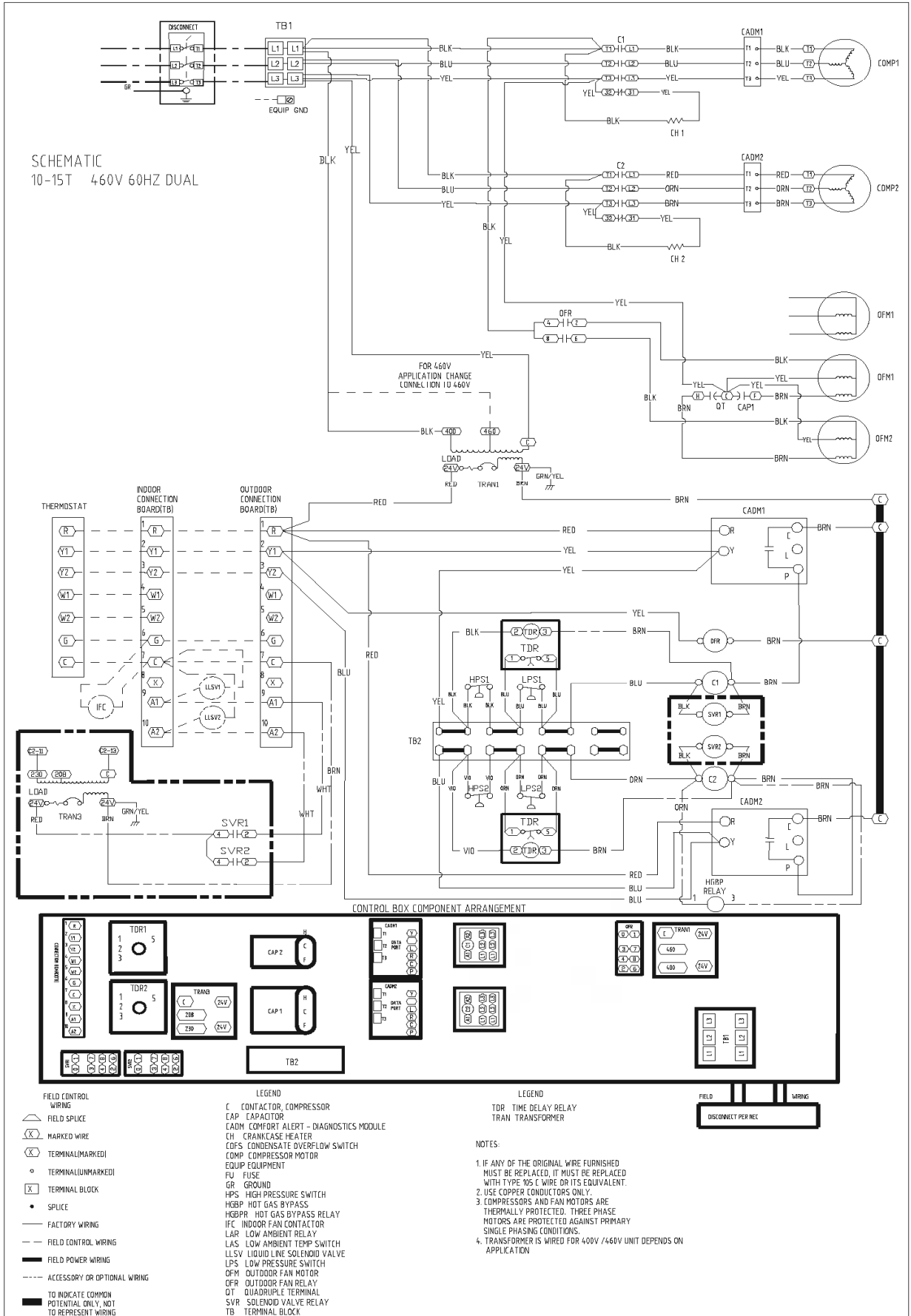

# CHARGING CHARTS

APPLICATION: 38AUZ07 (230-3-60)

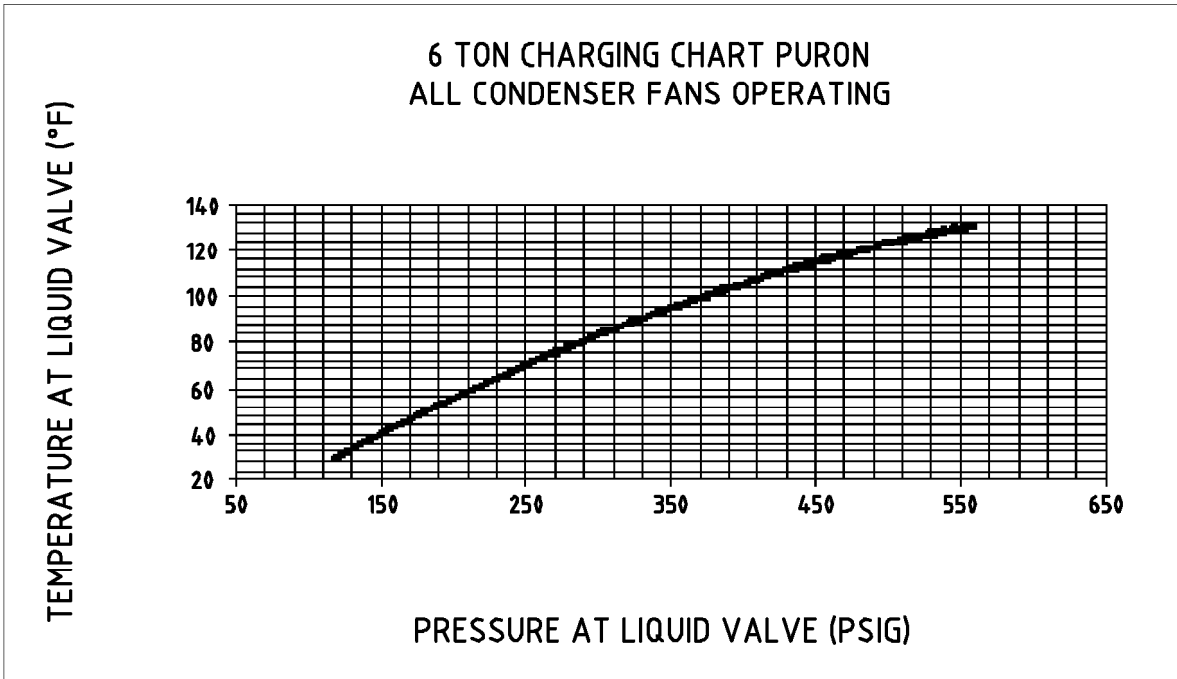

APPLICATION: 38AUZ08 (230-3-60)

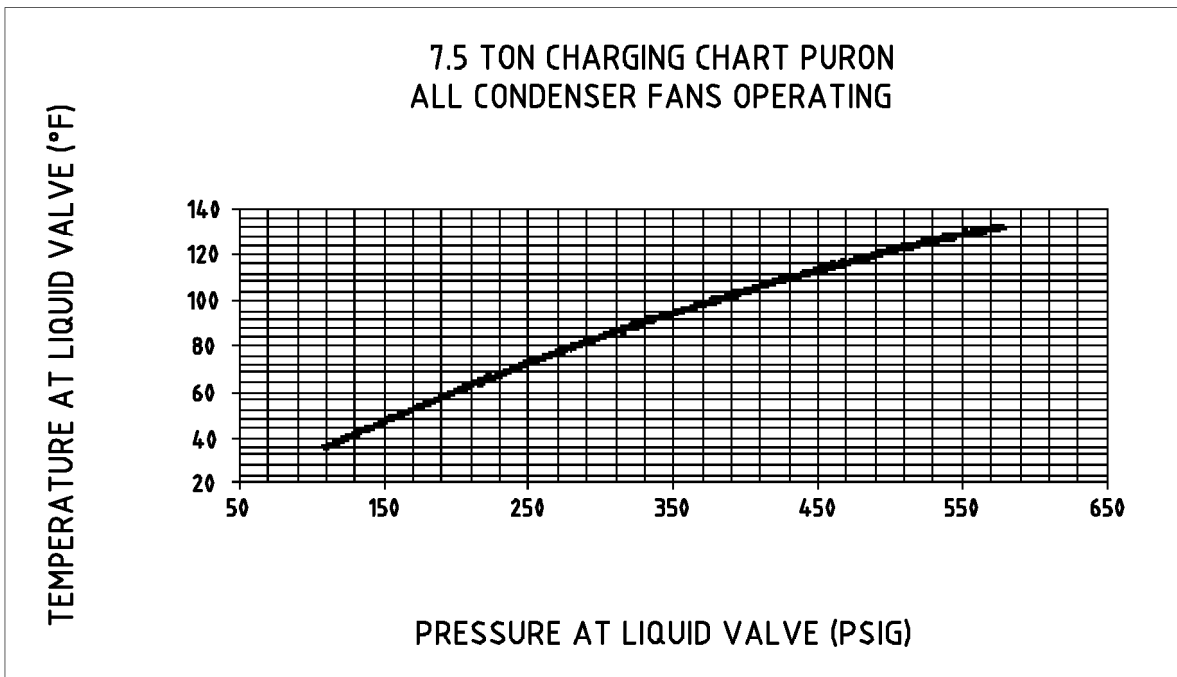

# CHARGING CHARTS (cont.)

APPLICATION: 38AUD12 (230-3-60)

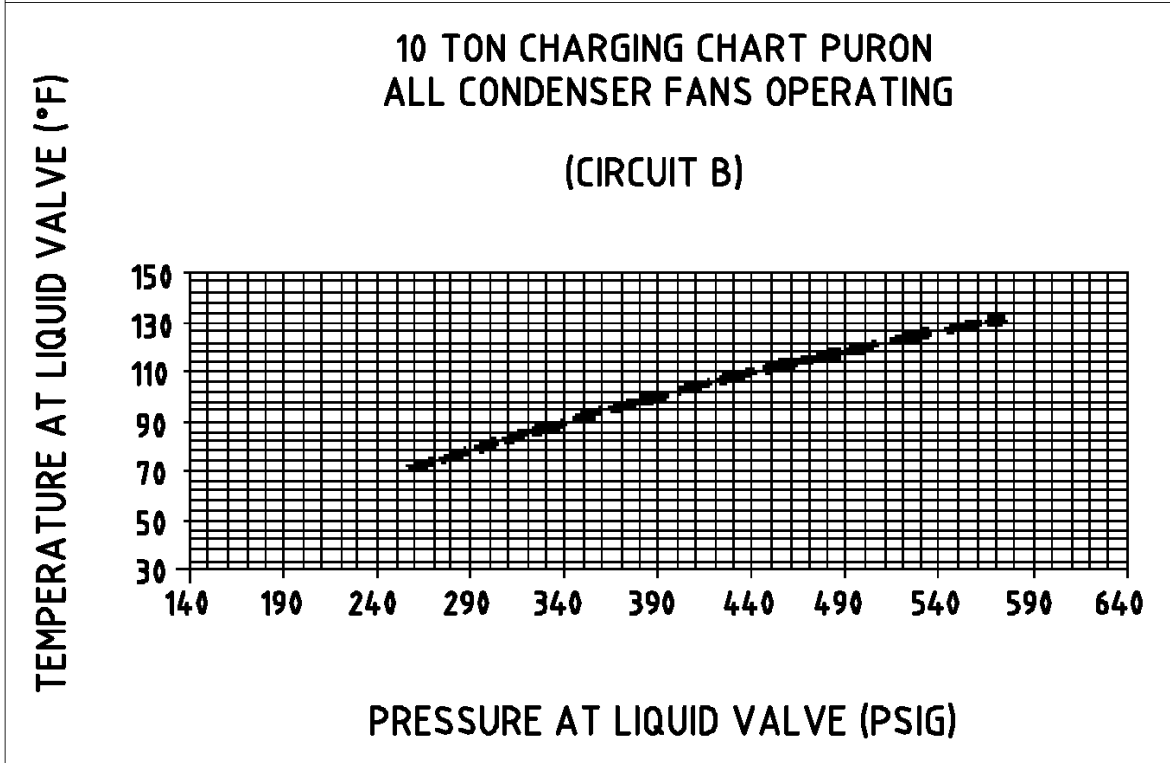
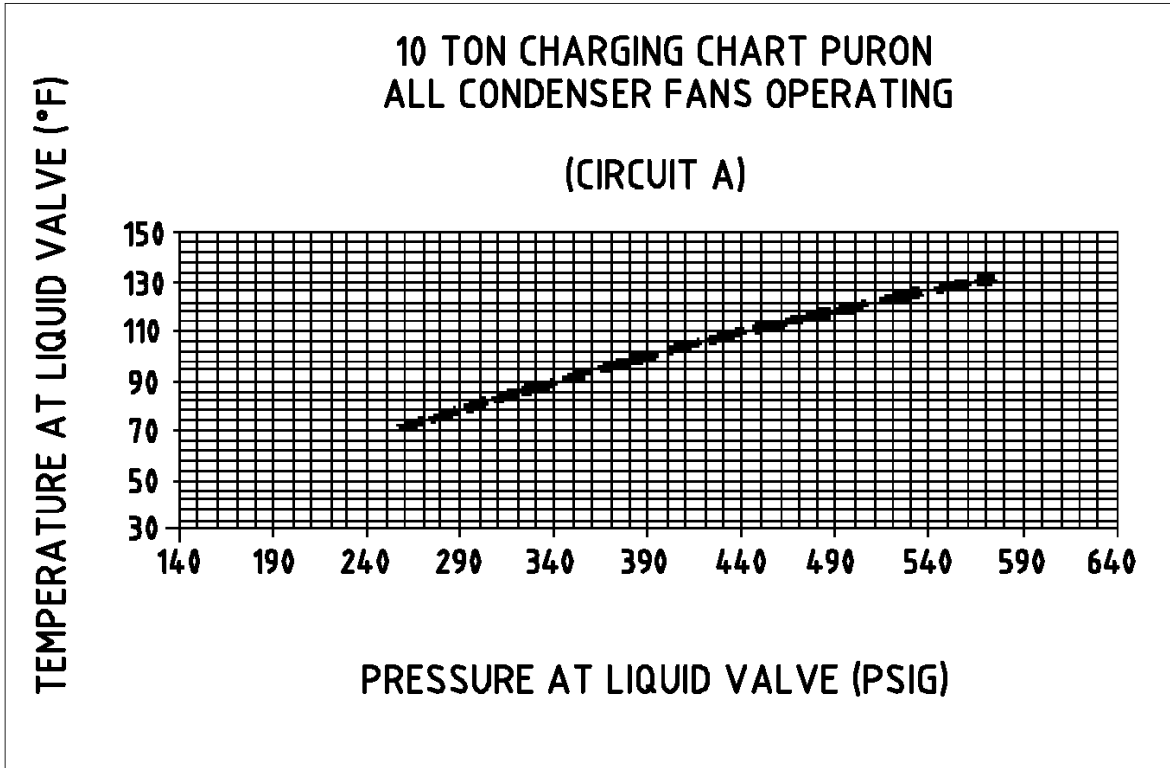

# CHARGING CHARTS (cont.)

APPLICATION: 38AUD14 (230-3-60)

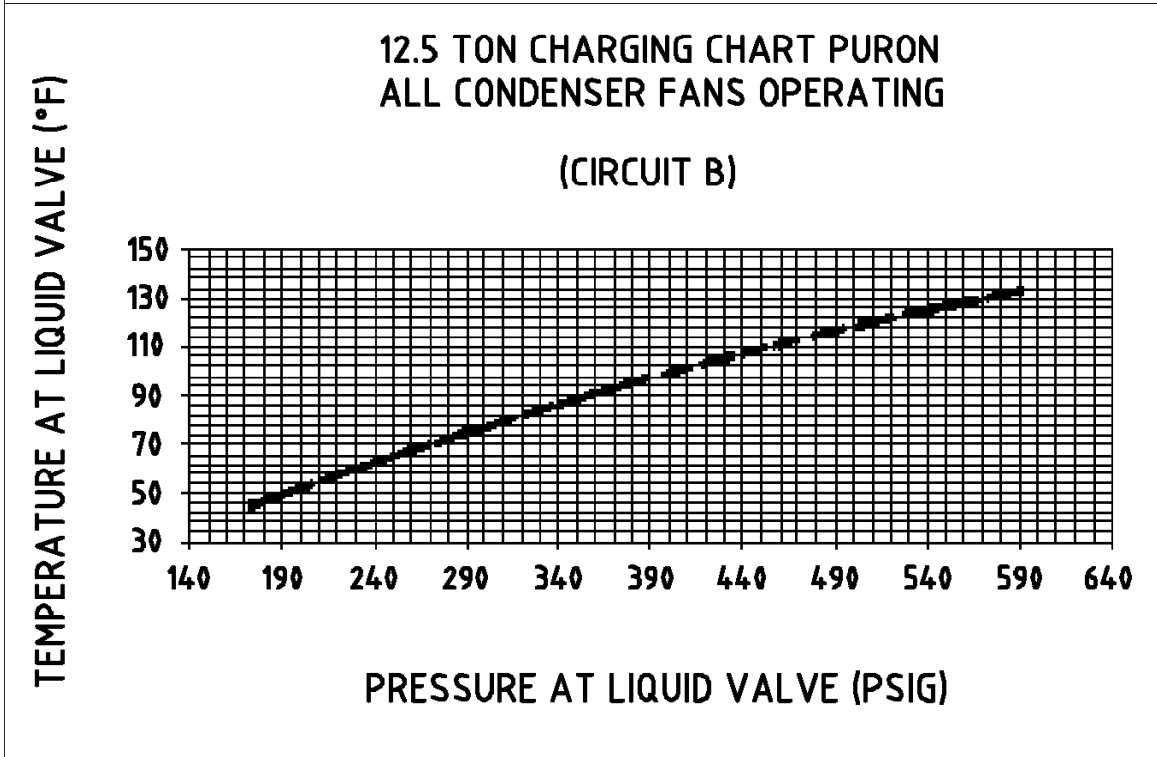
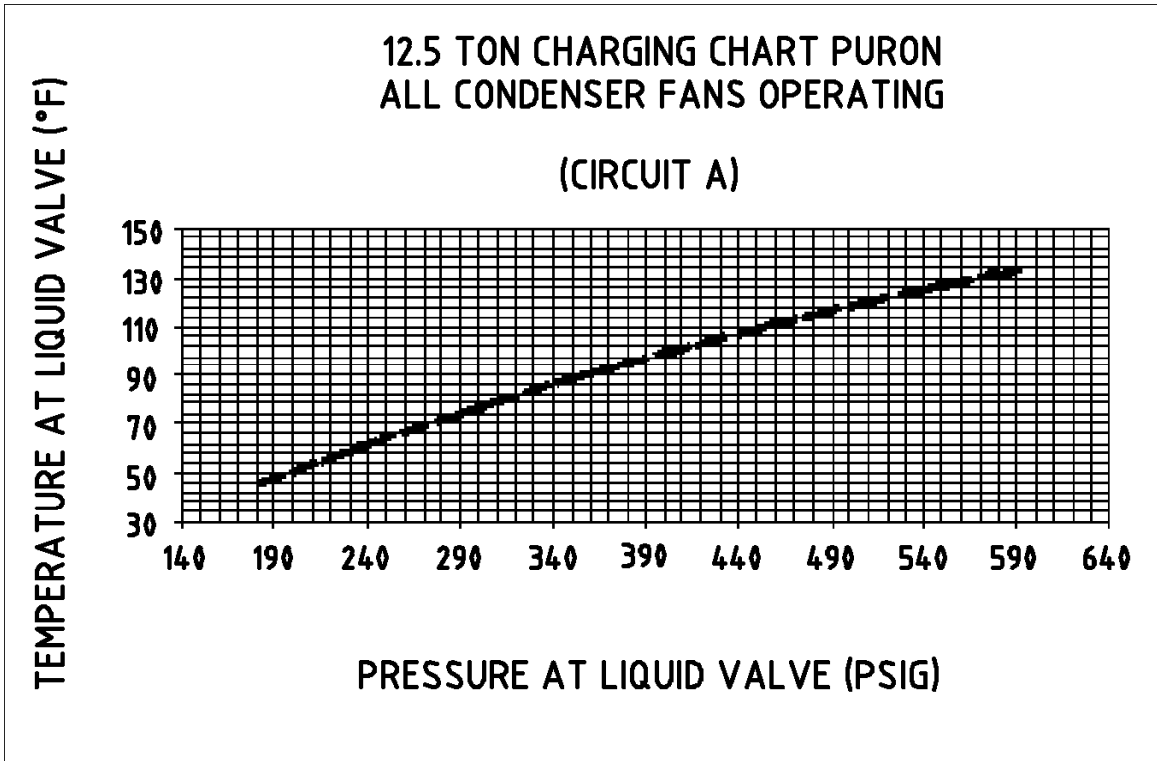

# CHARGING CHARTS (cont.)

APPLICATION: 38AUD16 (230-3-60)

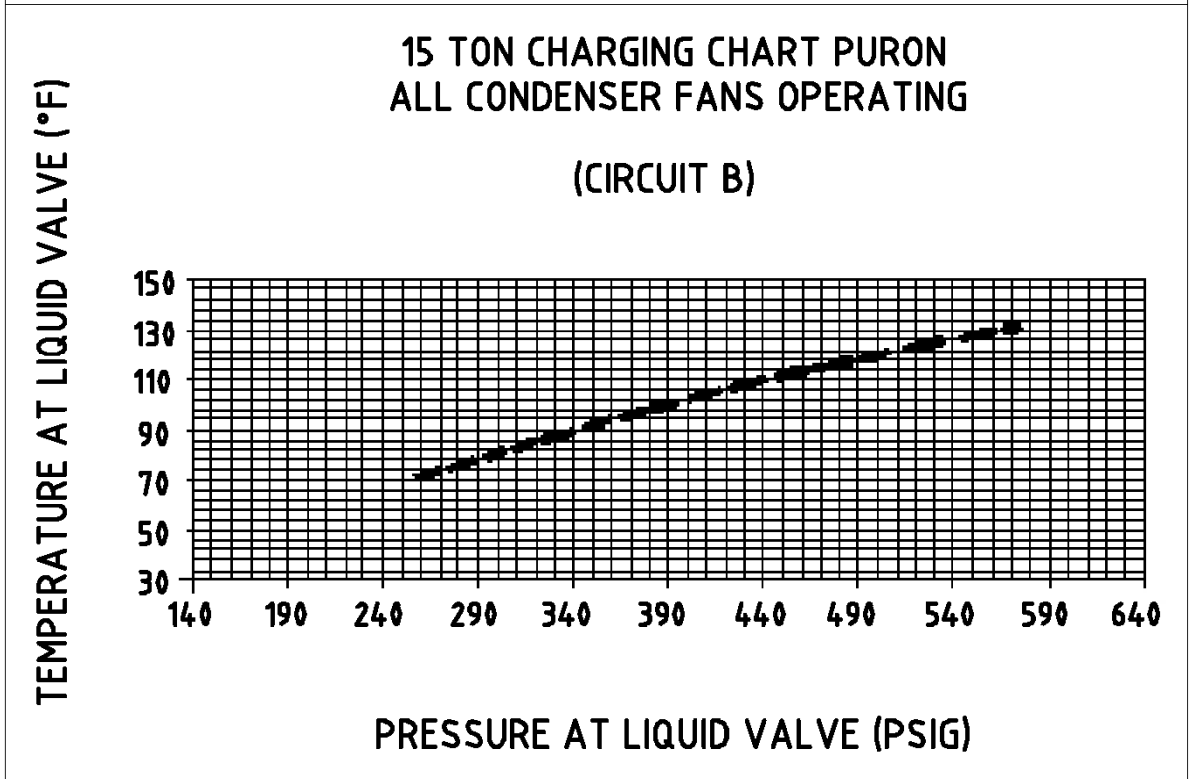
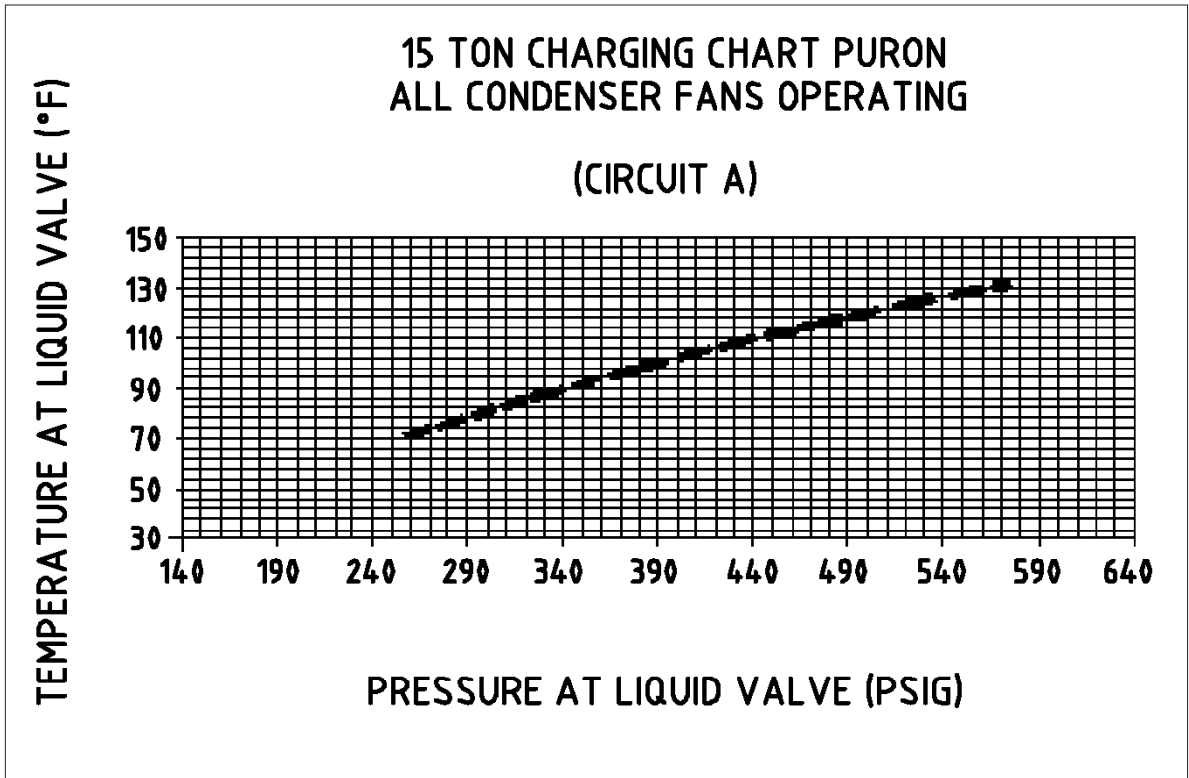



# CHARGING CHARTS (cont.)

APPLICATION: 38AUZ07 (400-3-60) (460-3-60)

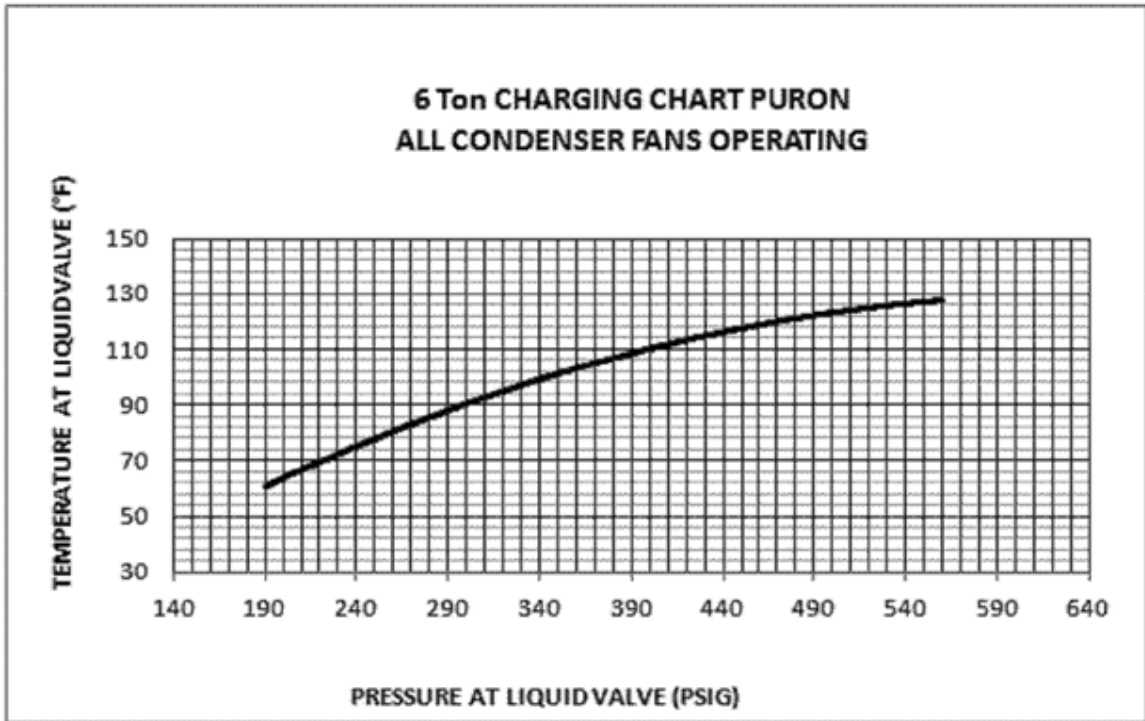

APPLICATION: 38AUZ08 (400-3-60) (460-3-60)

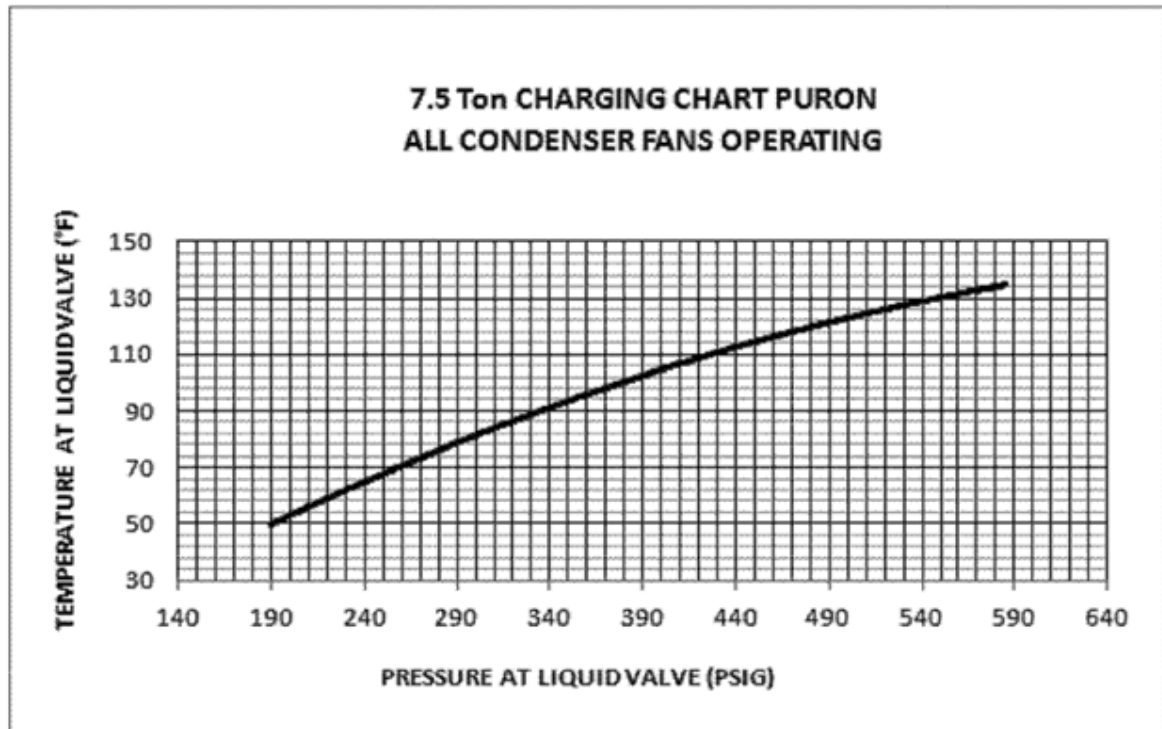

# CHARGING CHARTS (cont.)

APPLICATION: 38AUD12 (400-3-60) (460-3-60)

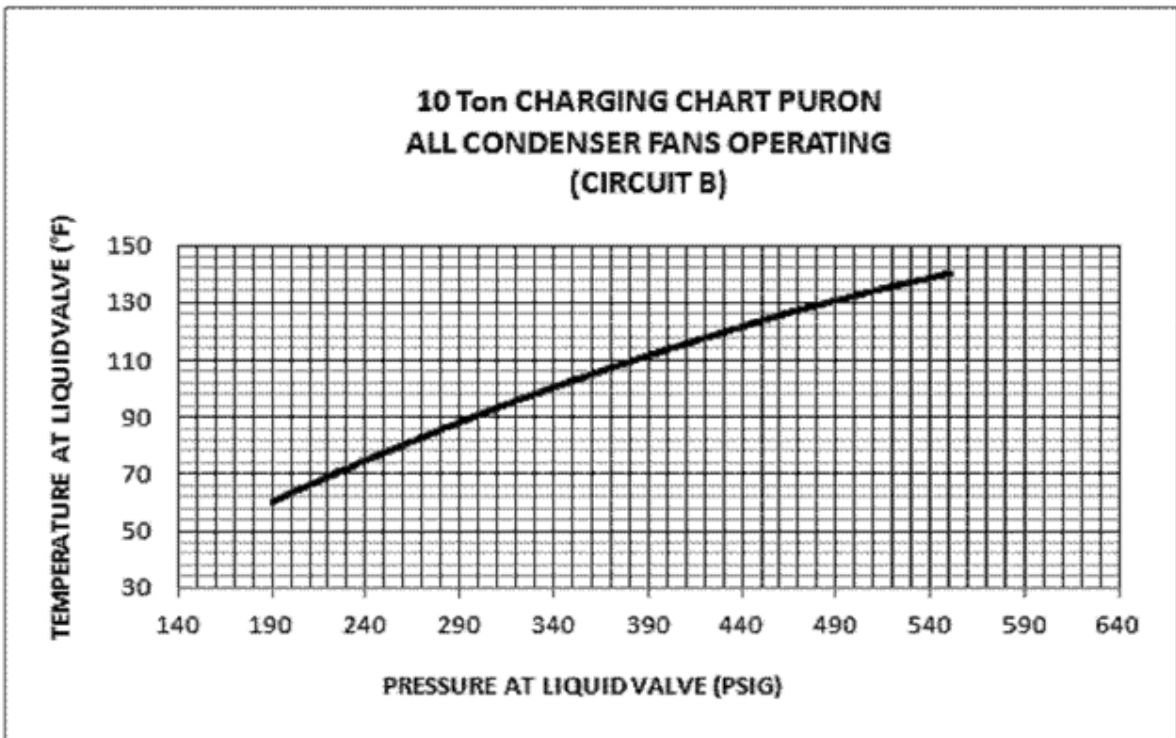
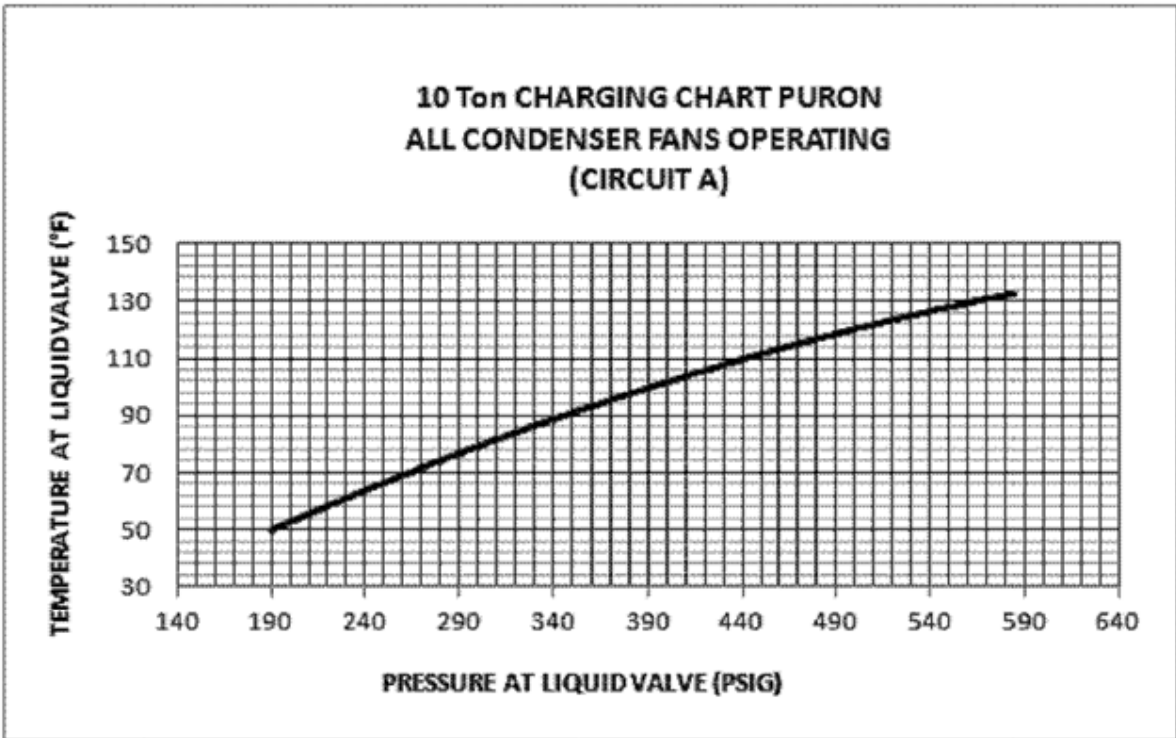

# CHARGING CHARTS (cont.)

APPLICATION: 38AUD14 (400-3-60) (460-3-60)

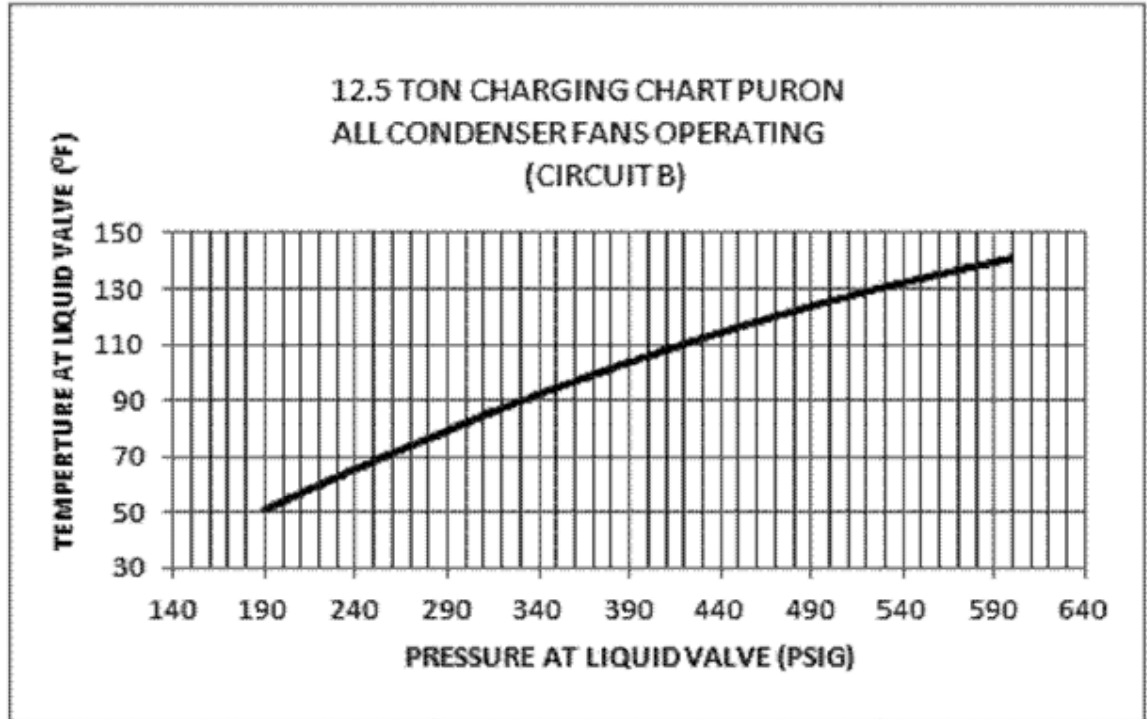
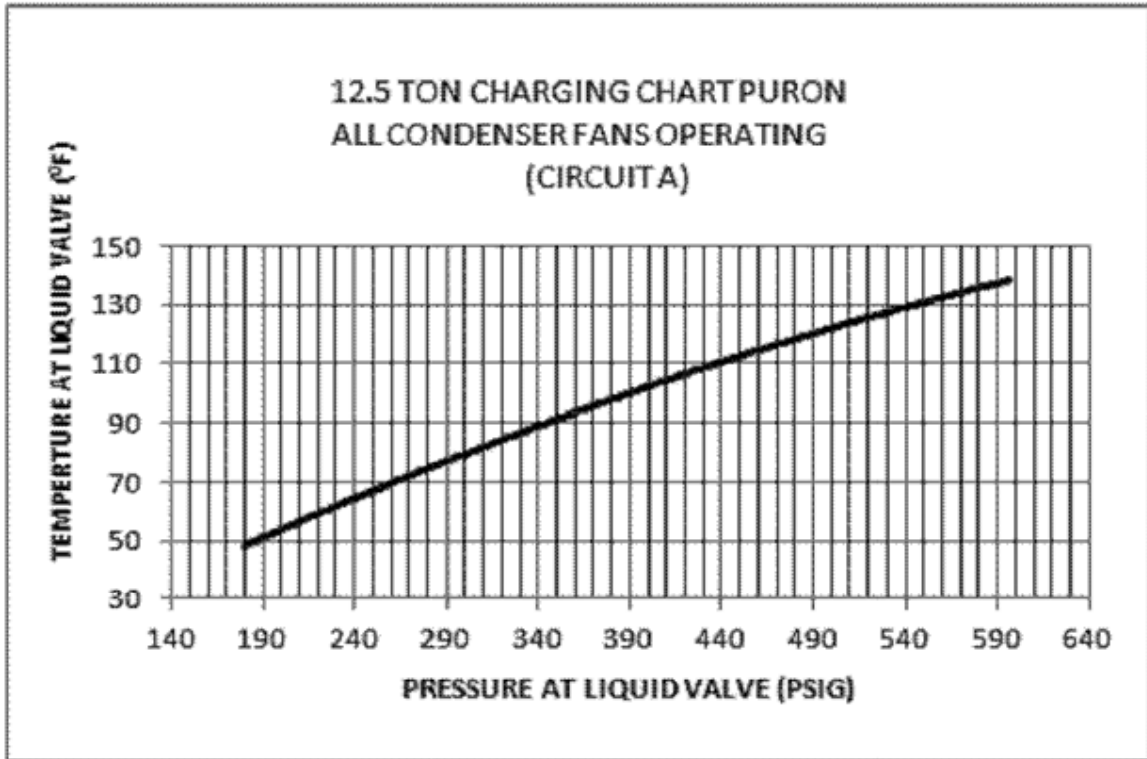

# CHARGING CHARTS (cont.)

APPLICATION: 38AUD16 (400-3-60) (460-3-60)

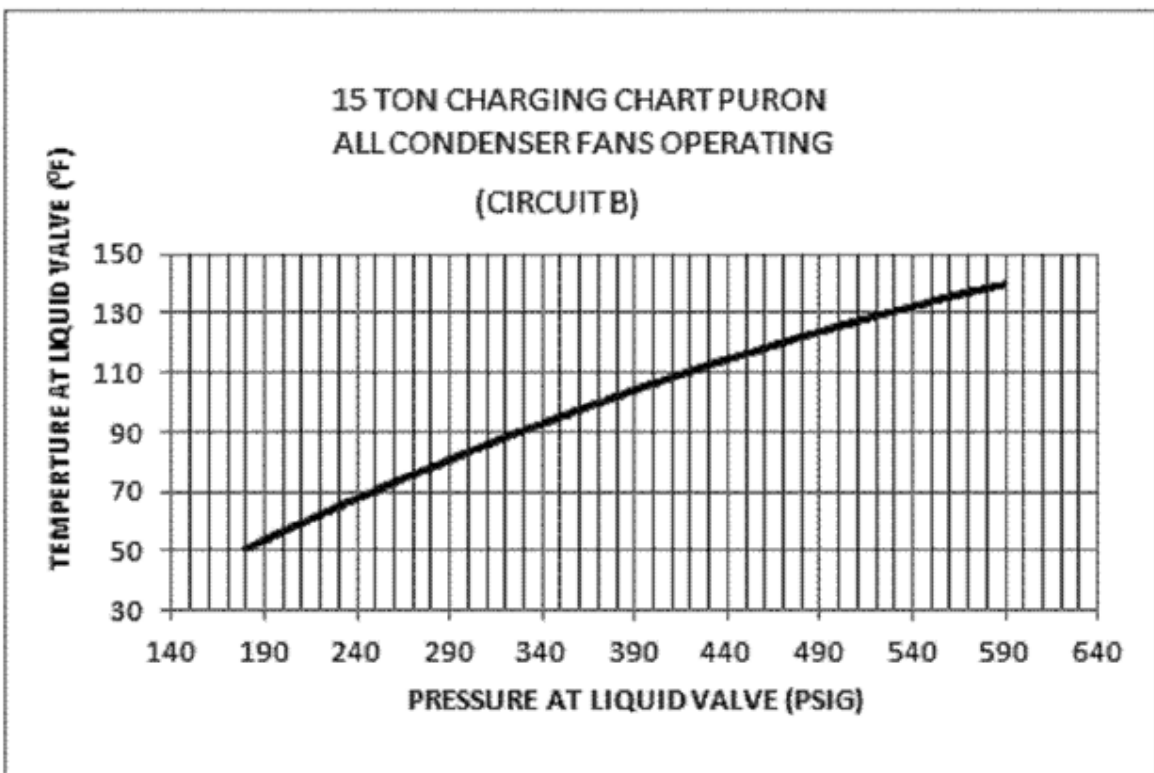
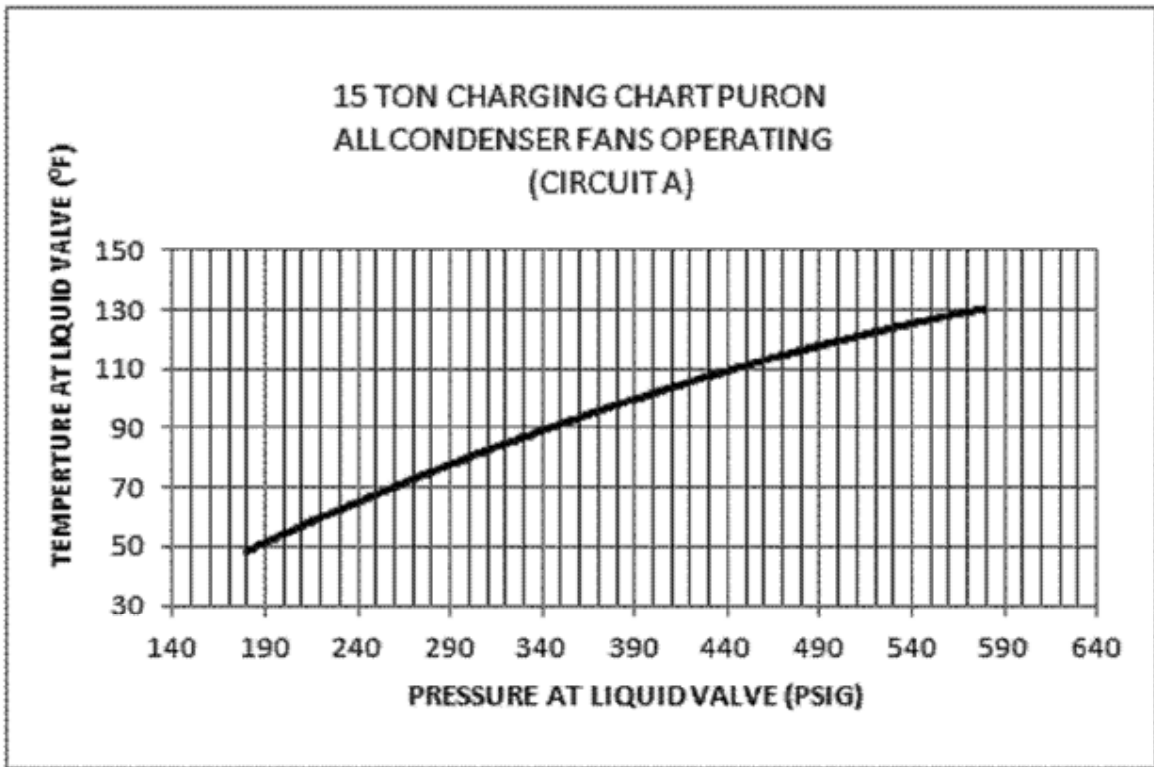

## ATTENTION INSTALLERS AND SERVICE TECHNICIANS!

### R-410A Refrigerant Quick Reference Guide

- R-410A refrigerant operates at 50-70 percent higher pressures than R-22. Be sure that servicing equipment and replacement components are designed to operate with R-410A refrigerant.
- R-410A refrigerant cylinders are rose colored.
- Recovery cylinder service pressure rating must be 400 psig, DOT 4BA400 or DOT BW400.
- R-410A refrigerant systems should be charged with liquid refrigerant. Use a commercial type metering device in the manifold hose when charging into suction line with compressor operating.
- Manifold sets should be 700 psig high side and 180 psig low side with 550 psig low-side retard.
- Use hoses with 700 psig service pressure rating.
- Leak detectors should be designed to detect HFC refrigerant.
- R-410A refrigerant, as with other HFCs, is only compatible with POE oils.
- Vacuum pumps will not remove moisture from oil.
- Do not use liquid-line filter driers with rated working pressures less than 600 psig.
- Do not leave R-410A refrigerant suction line filter driers in line longer than 72 hours.
- Do not install a suction-line filter drier in liquid-line.
- POE oils absorb moisture rapidly. Do not expose oil to atmosphere.
- POE oils may cause damage to certain plastics and roofing materials.
- Wrap all filter driers and service valves with wet cloth when brazing.
- A factory-approved liquid-line filter drier is required on every unit.
- Do NOT use an R-22 expansion device.
- If indoor unit is equipped with an R-22 expansion device, it must be changed to a hard-shutoff R-410A refrigerant expansion device.
- Never open system to atmosphere while it is under a vacuum.
- When system must be opened for service, recover refrigerant, evacuate then break vacuum with dry nitrogen and replace filter driers. Evacuate to 500 microns prior to recharging.
- All indoor coils must be installed with a hard-shutoff R-410A refrigerant expansion metering device.
- Do not vent R-410A refrigerant into the atmosphere.
- Do not use capillary tube coils.
- Observe all **warnings**, **cautions**, and **bold** text.

# Troubleshooting Guide

Cooling Service Analysis		
PROBLEM	CAUSE	REMEDY
Compressor and condenser fan will not start.	Power failure.	Call power company.
	Fuse blown or circuit breaker tripped.	Replace fuse or reset circuit breaker.
	Defective thermostat, contactor, transformer, or control relay.	Replace component.
	Insufficient line voltage.	Determine cause and correct.
	Incorrect or faulty wiring.	Check wiring diagram and rewire correctly.
Compressor will not start but condenser fan runs.	Thermostat setting too high.	Lower thermostat setting below room temperature.
	Faulty wiring or loose connections in compressor circuit.	Check wiring and repair or replace.
	Compressor motor burned out, seized, or internal over-load open.	Determine cause. Replace compressor.
	Defective overload.	Determine cause and replace.
	Compressor locked out	Determine cause for safety trip and reset lockout.
Compressor cycles (other than normally satisfying thermostat).	One leg of 3-phase power dead.	Replace fuse or reset circuit breaker. Determine cause.
	Refrigerant overcharge or undercharge.	Recover refrigerant, evacuate system, and recharge to nameplate.
	Defective compressor.	Replace and determine cause.
	Insufficient line voltage.	Determine cause and correct.
	Blocked condenser.	Determine cause and correct.
	Defective overload.	Determine cause and replace.
	Defective thermostat.	Replace thermostat.
	Faulty condenser-fan motor.	Replace.
Restriction in refrigerant system.	Locate restriction and remove.	
Compressor operates continuously.	Dirty air filter.	Replace filter.
	Unit undersized for load.	Decrease load or increase unit size.
	Thermostat set too low.	Reset thermostat.
	Low refrigerant charge.	Locate leak, repair, and recharge.
	Air in system.	Recover refrigerant, evacuate system, and recharge.
	Condenser coil dirty or restricted.	Clean coil or remove restriction.
Excessive head pressure.	Dirty drier filter.	Replace filter.
	Dirty condenser coil.	Clean coil.
	Refrigerant overcharged.	Recover excess refrigerant.
	Faulty TXV.	1. Check TXV bulb mounting and secure tightly to suction line. 2. Replace TXV if stuck open or closed.
	Air in system.	Recover refrigerant, evacuate system, and recharge.
	Condenser air restricted or air short-cycling.	Determine cause and correct.
Head pressure too low.	Low refrigerant charge.	Check for leaks, repair, and recharge.
	Restriction in liquid tube.	Remove restriction.
Excessive suction pressure.	High heat load.	Check for source and eliminate.
	Faulty TXV.	1. Check TXV bulb mounting and secure tightly to suction line. 2. Replace TXV if stuck open or closed.
	Refrigerant overcharged.	Recover excess refrigerant.
Suction pressure too low.	Dirty air filter.	Replace filter.
	Low refrigerant charge.	Check for leaks, repair, and recharge.
	Metering device or low side restricted.	Remove source of restriction.
	Faulty TXV.	1. Check TXV bulb mounting and secure tightly to suction line. 2. Replace TXV if stuck open or closed.
	Insufficient evaporator airflow.	Increase air quantity. Check filter and replace if necessary.
	Temperature too low in conditioned area.	Reset thermostat.
	Field-installed filter drier restricted.	Replace.

**MANDATORY START-UP CHECK LIST AND RECORD**

**IMPORTANT!**

This page is a mandatory checklist & record – the check to be executed and data to be recorded for future reference incase of failure. A copy of this checklist data has to be submitted to carrier representative. Completion of this checklist is a must for any field claim, no field support will be provided for incomplete or blank checklists.

**Preliminary Information**

Outdoor Model Number:	Outdoor Serial Number:
Indoor Model Number:	Indoor Serial Number:
Startup Date:	Technician Name:
Additional Accessories:	

TEAR ALONG THE DOTTED LINE

Pre-Start-Up Checklist			Yes	No	NA
<b>Outdoor Unit</b>					
Is there any shipping damage?					
If the unit is damaged, Please specify where:					
Will this damage prevent the unit start-up?					
Check power supply to see if it matches the unit data plate?					
Has the ground wire been properly connected?					
Are the circuit protection to the unit sized and installed properly?					
Are the power wires to the unit sized and intalled properly?					
<b>Piping</b>					
Are refrigerant lines connected to service valve sets?					
Are control power lines connected to control power terminal block?					
Are terminal snug in the housing?					
Are the service valves opened and backseated ?					
Are the Stem Valves Installed and snug?					
Have all the refrigerant connections and piping joints checked for leaks?					
<b>Indoor Fan Coil Unit Piping</b>					
Check if the accurater device is installed in fan coil unit?					
Have refrigerant connections been checked for leak?					
Is condensate line connected?					
Does condensate line drain freely?					
<b>Controls</b>					
Are control power lines and control cables routed separately (Not in the same conduit and not in same multi-conductor cable)?					
Are control wires connected to the same circuit as associated refrigerant lines?					
Check to make sure the subbase mounting to wall is secure? ( Don't apply excessive force to mounting screw)					
<b>Units With Wireless Remote Controller</b>					
Check mounting of interface board, are standoffs used to maintain fixed sepration above sheet metal chassis?					
Check connection of power supply plug (2-circuit mox plug) on interface board, is the blue lead connected to pin1?					
Are fresh batteries intalled properly in the fan coil remote controller?					
Does remote controller backlight illuminate when the button is pressed?					
<b>Fan System</b>					
Does fan rotate freely?					
Are air filters in place?					
<b>Indoor Power Supply</b>					
Does the power supply match the fan coil unit data plate?					
Is ground wire connected?					
<b>Start-Up Checklist</b>			Yes	No	NA
<b>Check Indoor Fan Operation Under Ceiling Fan Coil Units</b>					
Select fan mode, then initiate test sequence. Does the fan coil start at low speed , then shift to medium then to high?					
<b>Start System Operation at the Fan Coil Unit</b>					
Select cooling mode and adjust set point to be below current room temperature, Observe operation of outdoor condensing unit					
Does compressor start (After Initial Time Delay) and Run?					
Does outdoor fan run or cycle according to space requirements?					

De-select cooling mode at indoor fan coil unit, after atleast 15 minutes of running time and record all information below:

Outdoor Unit	
Compressor Amps(L1/L2/L3)	
Oil Pressure	
Vapor Line Pressure	
Vapor Line Temp	
Discharge Pressure	
Discharge Line Temp	
Entering Outdoor Air Temp	
Leaving Outdoor Air Temp	

Fan Coil Unit	
Indoor Entering Air dB(Dry Bulb) Temp	
Indoor Entering Air dB(Wet Bulb) Temp	
Indoor Leaving Air dB(Wet Bulb) Temp	
Indoor Leaving Air dB(Wet Bulb) Temp	

