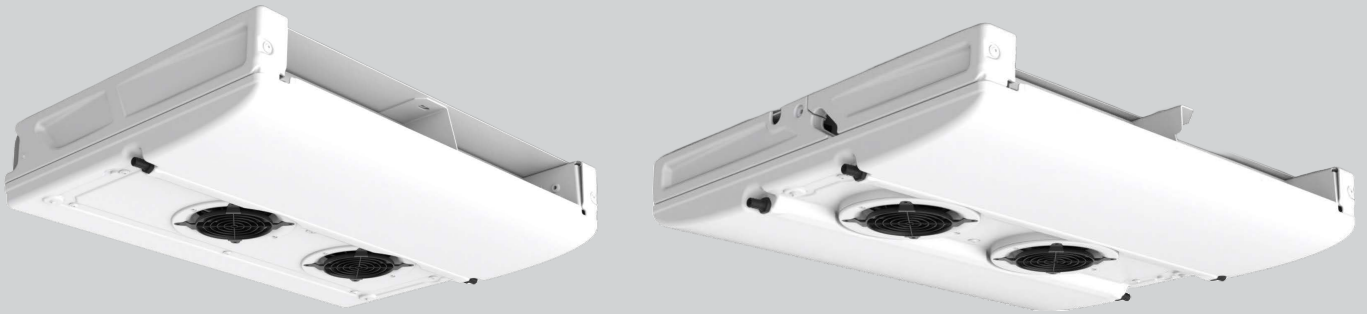


# Installation Manual

## Supra™ Series Remote Evaporators



**SUPRA**  
**SERIES**

62-90851



# 1 Safety

## 1.1 Warnings, Cautions and Notice Statements

Read these instructions carefully before operating the system. Safety alerts labeled DANGER, WARNING, and CAUTION alert to special instructions or precautions concerning procedures that would be hazardous if performed incorrectly or carelessly.

The safety alerts alone cannot eliminate all hazards. Strict compliance with these special instructions and common sense are major accident prevention measures.



Immediate hazards that will result in severe injury or death.



Hazards or unsafe practices that could result in severe personal injury or death.



Hazards of unsafe practices that could result in minor injury or product or property damage.



Information that is important to proper installation or maintenance but is not hazard related.

### 1.1.1 Safety Considerations

- Installation, service, and repairs on all systems must be performed by properly trained and qualified personnel. Some areas may require certification for servicing some equipment. Always follow the rules of the authority having jurisdiction and normal shop practice.
- Use caution when working around machinery. A TRU may start without notice. Always ensure equipment is locked out or disabled to prevent unexpected operation.
- Before performing any work, ensure the unit controller is in the OFF status, both battery cables disconnected, and any external shore power removed. Proper Lockout/Tagout procedures MUST be followed.
- All unit inspection/servicing by properly trained personnel only.



- DO NOT work under TRU or lifting device when TRU is not secured to truck box
- DO NOT stand under TRU when suspended from lifting device
- Diesel Fuel. Refer to Table 1
- Exercise safety precautions when working near flammable fuel.
- Low Voltage. Refer to Table 1
- Do not attach battery connections until installation is complete and unit is ready for commissioning
- Do not cut, drill, or modify any structural member of the truck cab or chassis

## **WARNING**

- **HOT PARTS.** Refer to Table 1
- **MOVING PARTS.** Refer to Table 1
- **HIGH Voltage.** Refer to Table 1
- **Once Automatic functions are set the system could start at any time. Before servicing the unit be sure to disconnect the unit from the batteries to prevent injury should the unit attempt to start while servicing. All presets will remain once battery cable is reconnected.**
- **Ensure holes in truck box are properly sealed and cables, harnesses, and hoses protected from abrasion, heat sources, and pinch points. Maintain minimum 0.5" (13mm) between edge of hole and cables, harnesses, and hoses.**

## **CAUTION**

- **Before beginning installation of the TRU system, disconnect the vehicle's batteries.**
- **Engine and exhaust system components may be hot**
- **Covers must be secure and installed while vehicle is moving**
- **Do not open cooling system when hot**
- **When heater is in use, the surface of the hot air inlet may become hot to the touch**
- **Contact with skin may cause burns**
- **Route fuel lines away from sharp edges, pinch points, and moving parts.**
- **Fuel lines must be protected from abrasion**
- **Keep fuel lines away from exhaust pipes or other heat sources**
- **The remote evaporators are heavy (single 73 lbs. 33 kg, dual 88 lbs. 40 kg). Do not drop**
- **Use lifting device or team lift when lifting the remote evaporators**

## **NOTICE**

- **Read before starting installation. Each truck body is unique and may require a different approach. Plan the placement of ALL components before beginning the installation.**
- **The remote evaporator requires periodic maintenance. Ensure there is access to internal components (i.e., valves, coils, etc.).**
- **Consult the truck owner prior to altering the vehicle in any way**
- **DO NOT use the mounting bolts to pull the remote evaporators to the box ceiling, damage may result**
- **DO NOT cut, drill, or modify remote evaporator frame or hardware**
- **Improper torquing of the mounting bolts may result in remote evaporator frame damage**
- **Keep host copper lines capped until refrigerant lines are installed  
DO NOT remove caps until ready to make connections**
- **DO NOT over tighten connections**
- **DO NOT twist or stress tubes when tightening hoses.**

## **NOTICE**






- **DO NOT** bend tubes to adjust alignment/fit
- **Use** backing wrench
- **Ensure** there is enough slack in the remote evaporator junction box wiring to allow for full movement of the junction box.
- **DO NOT** force the remote evaporator skin onto the remote evaporator the skin may crack. There are tabs on each style of remote evaporator that allow the skin to stay in place
- **Ensure** all electrical connections are correct and secure.

Hazard	Cautions	Preventative Actions
<b>Diesel Fuel</b>	<ul style="list-style-type: none"> <li>• Combustible liquid.</li> <li>• May cause cancer.</li> <li>• Irritating to eyes and skin.</li> </ul>	<ul style="list-style-type: none"> <li>• Use personal protective equipment.</li> <li>• Ensure adequate ventilation.</li> <li>• Material can create slippery conditions.</li> <li>• Avoid contact with skin, eyes, and clothing.</li> <li>• Do not ingest.</li> <li>• Keep away from heat and sources of ignition.</li> </ul>
<b>Coolant</b>	<ul style="list-style-type: none"> <li>• Contact can cause slight irritation of skin, eyes, and respiratory tract. Extremely dangerous in case of ingestion.</li> <li>• Do NOT induce vomiting, call doctor/physician or poison center</li> <li>• Do not breathe mist, spray, vapors</li> </ul>	<ul style="list-style-type: none"> <li>• Coolant may be extremely hot and under pressure, allow the engine to cool before opening the cooling system.</li> <li>• Avoid contamination with reactive substances. After handling, always wash hands thoroughly with soap and water.</li> </ul>
<b>Hot Parts</b>	Avoid contact with the engine or exhaust components.	Allow the engine to cool before working on it. The engine cooling system may be connected to some components. See coolant warnings.
<b>Moving Parts</b>	Avoid working inside the remote evaporator enclosure when the unit is running. The TRU may start at any time. Fans in the host and remote evaporators may start without warning.	Before performing any work, turn OFF the cab command, disconnect the battery cables, lockout both battery ends, and remove shore power if equipped. Proper lockout/tagout procedures must be followed.
<b>High Voltage</b>	System contains high voltage circuits at levels that can cause serious injuries or death	
<b>Low Voltage</b>	<ul style="list-style-type: none"> <li>• Low voltage battery connections have sufficient current capabilities to weld tools if they cross the battery terminals. This may result in severe sparks, heat, and possible explosions.</li> <li>• The hydrogen gas produced when charging is very explosive. Avoid heat, sparks, and open flame while charging batteries. Avoid contact with internal acid. May form explosive air/gas mixture during charging. Contact with internal components may cause irritation or severe burns. Irritating to eyes, respiratory system, and skin.</li> <li>• Prolonged inhalation or ingestion may result in serious damage to health.</li> </ul>	<ul style="list-style-type: none"> <li>• Always disconnect the battery prior to working on the TRU.</li> <li>• EYES: Direct contact of internal electrolyte liquid with eyes may cause severe burns or blindness.</li> <li>• SKIN: Direct contact of internal electrolyte liquid with the skin may cause skin irritation or damaging burns.</li> <li>• INGESTION: Swallowing this product may cause severe burns to the esophagus and digestive tract and harmful or fatal lead poisoning. Lead ingestion may cause nausea, vomiting, weight loss, abdominal spasms, fatigue, and pain in the arms, legs, and joints.</li> <li>• INHALATION: Respiratory tract irritation and possible long-term effects.</li> </ul>
<b>Heavy Objects</b>	Components may be of sufficient weight to cause personal injuries or death if they fall or are dropped.	Always wear proper personal protective equipment to prevent injuries from falling objects. Always use proper equipment when moving heavy objects and ensure that they are stable. Get assistance if required.
<b>R-452A Refrigerant</b>	<ul style="list-style-type: none"> <li>• Contact with liquid or refrigerated gas can cause cold burns and frostbite.</li> <li>• May cause skin irritation.</li> <li>• May cause: Discomfort, itching, redness, or swelling.</li> <li>• May cause eye irritation.</li> </ul>	<ul style="list-style-type: none"> <li>• Use personal protective equipment including safety glasses and protective gloves.</li> <li>• Ensure adequate ventilation.</li> <li>• Avoid contact with skin, eyes, and clothing.</li> <li>• Do NOT allow the release of R-452A to the atmosphere</li> <li>• Misuse or intentional inhalation abuse may cause death without warning symptoms.</li> <li>• Vapors are heavier than air and can cause suffocation by reducing oxygen available for breathing.</li> <li>• Eye contact: In case of contact, immediately flush eyes with plenty of water for at least 15 minutes. Consult a physician if necessary.</li> </ul>

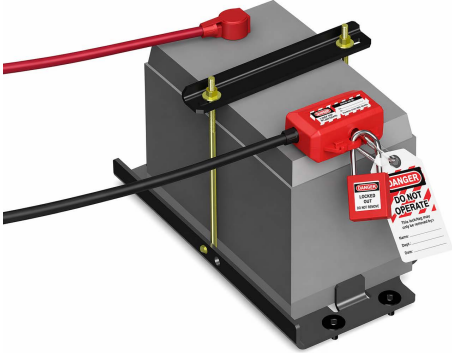
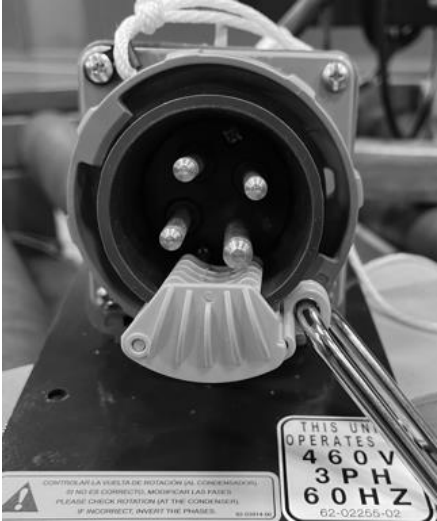
**Table 1 Hazards and Preventative Actions**

## 1.2 Lockout-Tagout Equipment

The following equipment is required to perform lockout-tagout (LOTO) on the Supra Series TRU

Battery Cable Lockout		<ul style="list-style-type: none"> <li>• Battery cable lockout is used on the TRU battery cables and disables the 12 VDC power source for the TRU.</li> <li>• In some applications there may be potential ground path through the TRU and truck frames so BOTH the B+ and B- cables must be disconnected and locked out.</li> <li>• Use battery cable lockout that has interior post that keeps the cable lug in place.</li> <li>• Use separate lockouts for the B+ and B- cables</li> </ul>
Starter Lockout		<ul style="list-style-type: none"> <li>• Starter lockout is used on the starter solenoid disconnect.</li> <li>• Use to prevent engine from starting during inspections or troubleshooting</li> <li>• Use lockout that has appropriately sized opening to keep starter solenoid disconnect in place.</li> </ul>
Lockout Hasp		<ul style="list-style-type: none"> <li>• Hasp is used to lockout the shore power receptacle.</li> <li>• Use hasp that does not rotate on receptacle cover when installed</li> </ul>
Lockout Lock		<ul style="list-style-type: none"> <li>• Secures lockouts and hasps</li> </ul>
Plug Lockout		<ul style="list-style-type: none"> <li>• Secure vehicle keys</li> </ul>

## 1.2.1 Lockout/Tagout locations for Supra TRU

Battery Cables		<ul style="list-style-type: none"><li>• Disconnect the TRU B+ and B- battery cables from the TRU/truck batteries.</li><li>• Apply battery cable lockout to each of the battery cable ends</li><li>• Refer to truck OEM and local regulations for additional battery cable lockout requirements</li></ul>
Shore Power		<ul style="list-style-type: none"><li>• Lift shore power receptacle cover and apply hasp at the hinge point.</li><li>• Lock hasp with lockout lock</li></ul>

## 2. Components

The MSS (Single) and MSD (Dual) discharge evaporators provide temperature control for multiple compartments/temperatures within an insulated cargo box. The configuration and location of the remote evaporators can be optimized to meet customer needs. The compressor and condenser are located in the host unit with refrigerant lines (liquid, hot gas, and suction) connecting to the remote evaporators. High voltage AC and low voltage DC power are supplied from the host to each remote evaporator through dedicated/separated harnesses. Electrical connections are made at a junction box at each remote evaporator. The operator can turn each compartment on/off, change compartment setpoint, and initiate defrost from the cab command. Evaporator condensate is drained through defrost drains located on the side of the evaporator.

### 2.1 Remote Evaporator Models

MSS (Single Discharge) MSS11\_224\_7G10\*

MSD (Dual Discharge) MSD11\_224\_7G10\*

**\*NOTE: Only MSS11\_224\_7G10 and MSD11\_224\_7G10 are used in North America**

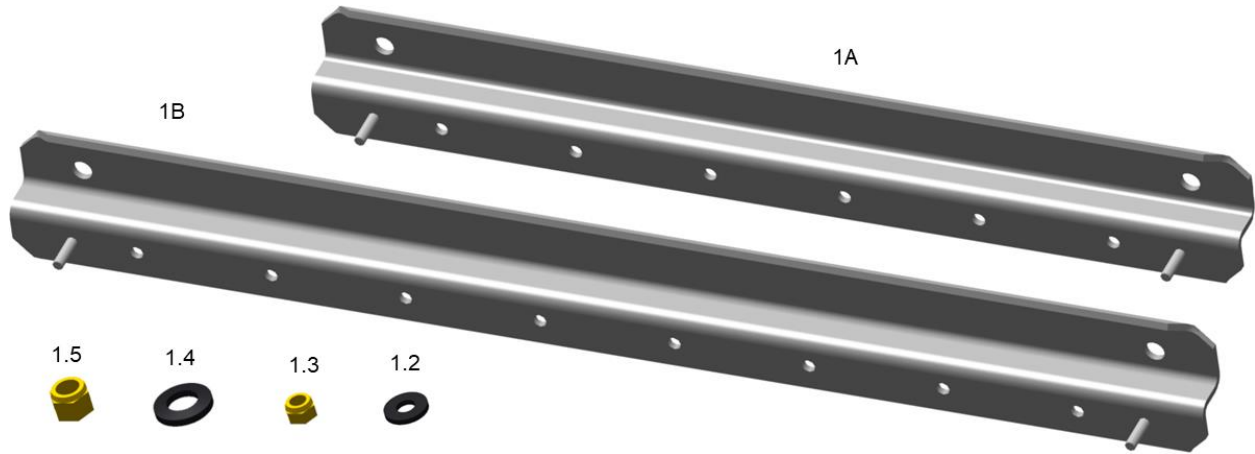
#### 2.1.1 Installation Requirements

Component	Requirement
<b>Remote Evaporator</b>	Do not drill additional holes in remote evaporator frame.
	Use adapter brackets if required.
	Mounted to ceiling of refrigerated box/compartment.
	Installed in manner so that minimum clearance requirements are maintained. See Table 5
	If additional guard is installed, it must allow access to remote evaporator for inspection and service.
	Lifting device used for removal and installation.
<b>Defrost Drain</b>	Defrost drain must be installed
	Drain hose sloped away from evaporator to allow water to drain.
	Drain heater must be installed in the drain hose.
<b>Refrigerant Tubing</b>	Installed in manner that minimizes potential damage to tubing while equipment is in use.
	Use inert gas brazing process
	Brazing alloy
	Refrigeration magnet
	Secured minimum every 12.00"
<b>Wiring Harness</b>	Insulation
	Separate high and low voltage harnesses.
	Secure harness minimum every 12.00" and at start/end of bends.
	Routed to avoid sharp edges, pinch points, heat sources, and physical damage.
	Not in contact with refrigerant tubing.

#### 2.1.2 Installation Kit Parts

The following tables are representative of the parts that are included in the installation kits. Parts and quantities included may vary by model and are subject to change. The parts contained within each kit are packaged so that the parts required for each section are contained within the same bag/box.

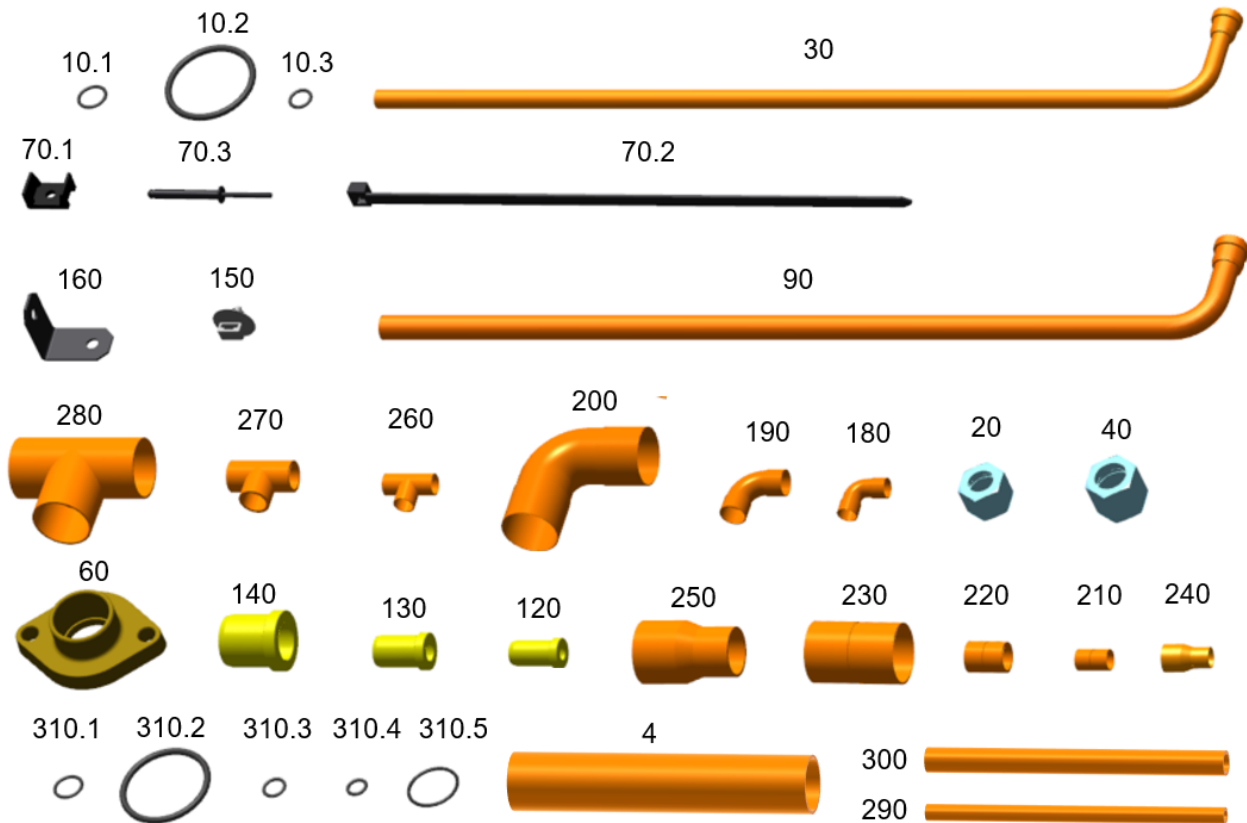
### 2.1.3 Remote Evaporator Adapter Kit (76-61646-00 Single or 76-61646-01 Dual)



Item	QTY	Number	Name	Part Qualifier
1A	2	67-61378-00	EVAPORATOR ADAPTER	EVAP MT 1100 (SINGLE)
1B	2	67-61378-01	EVAPORATOR ADAPTER	EVAP MT 1100 (DUAL)
1.2	4	34-00616-07	WASHER,SPECIAL	3/8,18-9,SS
1.3	4	34-00361-12	NUT,SELF LOCK	5/16-18
1.4	4	34-60085-12	WASHER	12 ID 24 OD
1.5	4	34-00361-15	NUT,SELF LOCK	1/2-13

Table 2

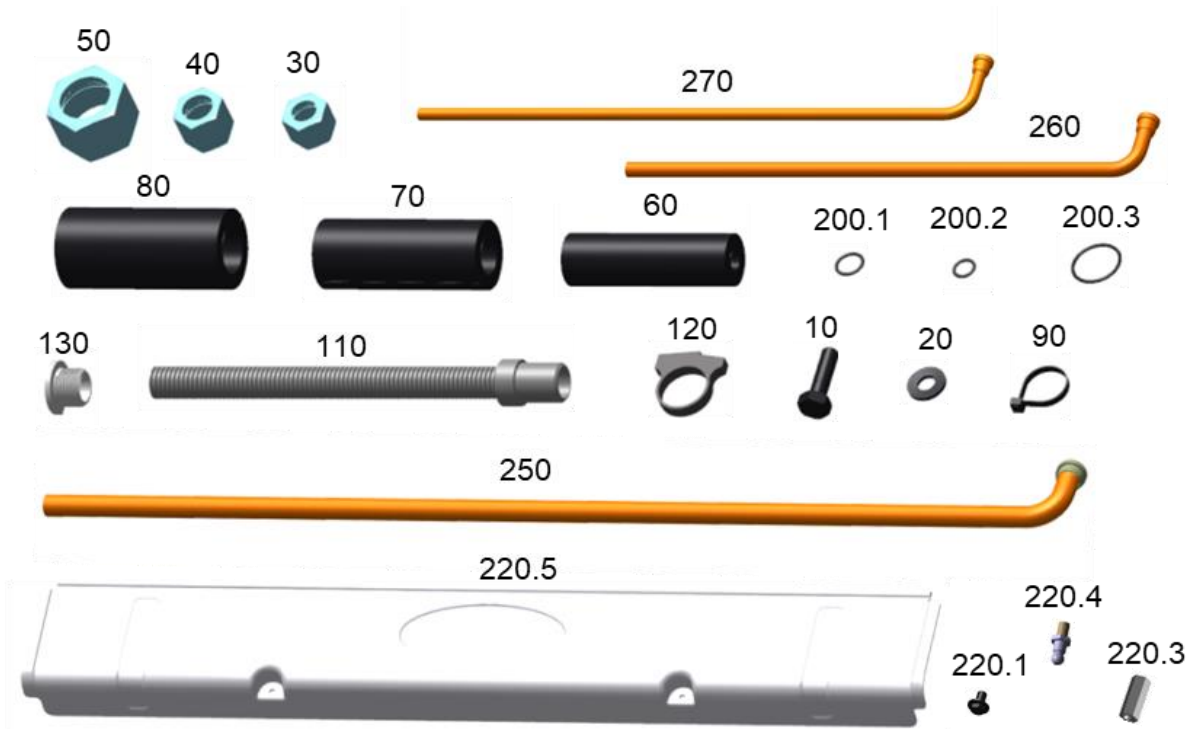
### 2.1.4 Remote Evaporator Installation Kit (76-61463-80)



Item	Quantity	Number	Name	Part Qualifier
10.1	1	42-00243-04	O-RING	0.489 x 0.070
10.2	1	42-00243-06	O-RING	1.609 x 0.139
10.3	1	42-00243-09	O-RING	0.364 x 0.070
20	1	40-60009-02	NUT,ORS	#6 X 3/8OD TUBE
30	1	82-60021-09	TUBE,COPPER	INTERFACE CTRL DRW
40	1	40-60009-03	NUT,ORS	#8 X 1/2OD TUBE
60	1	40-60206-00	ADAPTER,FLANGE	1'1/8 WITHOUT GROOVE
70.1	10	40-60061-00	BASE	CABLE TIE
70.2	30	44-60024-25	TIE	CABLE
70.3	10	34-60264-01	RIVET	0.189 x (0.275-0.511)
90	1	82-60021-10	TUBE,COPPER	INTERFACE CTRL DRW
100	1	62-61619-00	DECAL	LOCATE COMPARTMENT
120	2	40-01190-02	SLEEVE	ORS, 3/8" OD TUBE
130	2	40-01190-00	SLEEVE	ORS, 1/2" OD TUBE
140	2	40-01190-03	SLEEVE	ORS, 7/8" OD TUBE
150	4	44-60121-00	BRACKET,CLAMP	FOR TIE-WRAP
160	4	68-71221-00	BRACKET,CLAMP	1.5 MM THK ALUM
170	1	98-60744-00	INSTRUCTION	DRAIN HOSE WATER EV
180	7	40-01219-00	ELBOW 90°	3/8C X 3/8C SR
190	7	40-01219-01	ELBOW,90 DEG	1/2C X 1/2C SR
200	5	40-01219-03	ELBOW,90 STREET	1-1/8C X 1-1/8C SR
210	3	40-00091-03	COUPLING	3/8 SOL X SOL
220	3	40-00091-04	COUPLING	1/2 SOL X SOL
230	3	40-00091-09	COUPLING	1-1/8 ID X 1-1/8 ID
240	2	40-01197-01	COUPLING	1/2C X 3/8C
250	2	40-00130-17	COUPLING	1-1/8C X 7/8C
260	1	40-00168-03	TEE	3/8C X 3/8C X 3/8C
270	1	40-00168-04	TEE	1/2C X 1/2C X 1/2C
280	1	40-00168-09	TEE	1.12C X 1.12C X 1.12C
290	1	56-00141-04	TUBE,COPPER	3/8OD X .028W,50FT
300	1	56-00142-93	TUBE,COPPER	1/2OD X .035W,50FT
310.1	2	42-00243-04	O-RING	0.489 x 0.070
310.2	2	42-00243-06	O-RING	1.609 x 0.139
310.3	2	42-00243-09	O-RING	0.364 x 0.070
310.4	2	42-00243-10	O-RING	0.301 x 0.070
310.5	2	42-00243-16	O-RING	0.926 x 0.070

**Table 3**

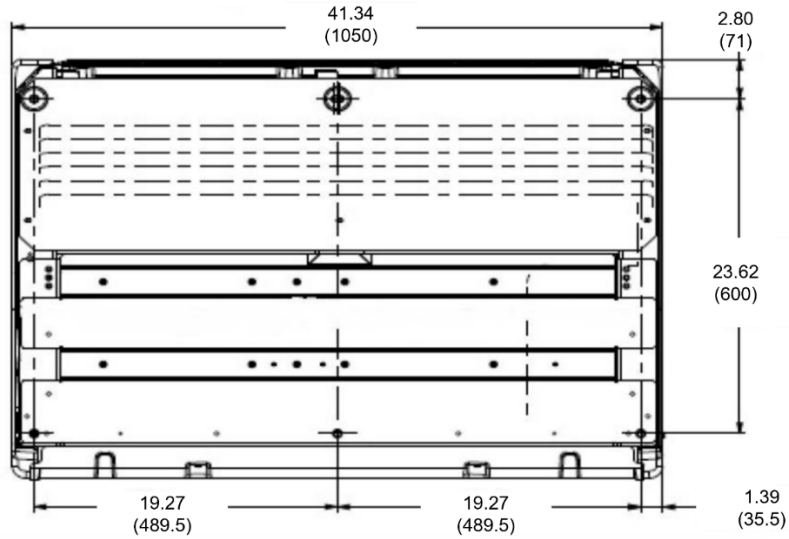
## 2.1.5 Remote Evaporator Installation Kit (76-61639-10) Part of Remote Evaporator



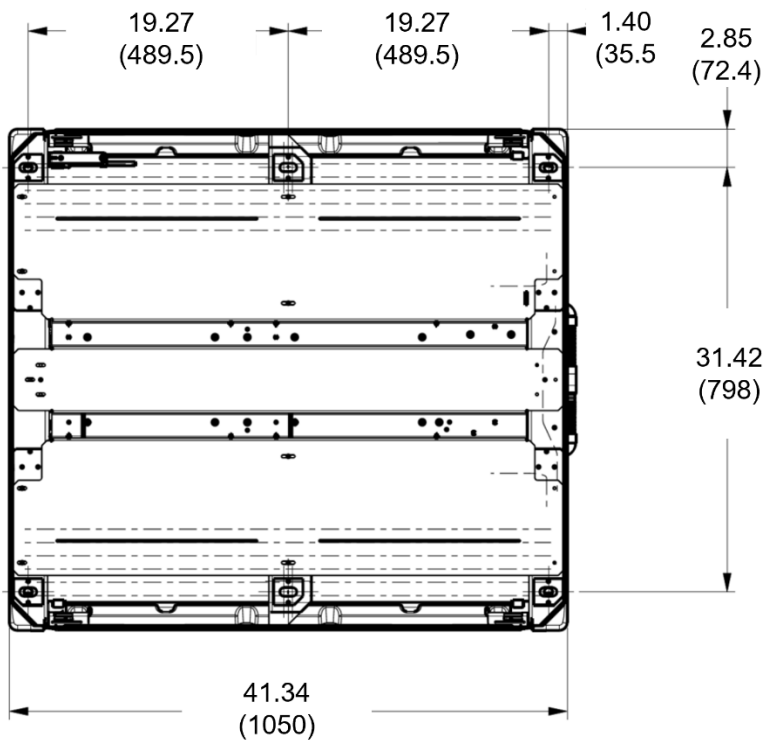
Item	QTY	Number	Name	Part Qualifier
10	6	34-00873-35	SCREW,CAP HXHD	M10 X 35MM(1.38)LG
20	6	34-60085-10	WASHER	M10 X 22OD CONICAL
30	1	40-60009-02	NUT,ORS	#6 X 3/8OD TUBE
40	1	40-60009-03	NUT,ORS	#8 X 1/2OD TUBE
50	1	40-60009-06	NUT,ORS	#14 X 7/8OD TUBE
60	6	42-60007-10	INSULATION,TUBE	1/2" I.D.
70	6	42-60007-12	INSULATION,TUBE	7/8" I.D.
80	6	42-60007-13	INSULATION,TUBE	1"1/8 I.D.
90	1	44-60024-09	STA-STRAP	0-50 MM DIA BUNDLE
110	2	58-60926-01	TUBE,WATER	17.5MM ID X 3500MM
120	2	58-00712-12	CLAMP,HOSE	.859-0.989 O.D.SNAP
130	1	58-60911-00	FITTING	CAP
200.1	1	42-00243-04	O-RING	0.50 ID X 0.62 OD
200.2	1	42-00243-09	O-RING	0.38 ID X 0.50 OD
200.3	1	42-00243-16	O-RING	0.94 ID X 1.06 OD
220	1	79-60834-00	BACK PANEL KIT	MTS 1100
220.1	2	34-60206-10	SCREW,HEX WSHRH	H M6 X 10
220.3	2	58-60523-01	SPACER	10X25
220.4	2	44-60171-00	COUPLING,HALF	DIA 7
220.5	1	58-60879-00	PANEL,BACK	MTS 1100-15
251	1	81-60143-06	TUBE,SUCTION	
260	1	82-60021-02	TUBE,LIQUID	INTERFACE_CTRL_DWG
270	1	82-60021-08	TUBE,COPPER	INTERFACE_CTRL_DRW

Table 4

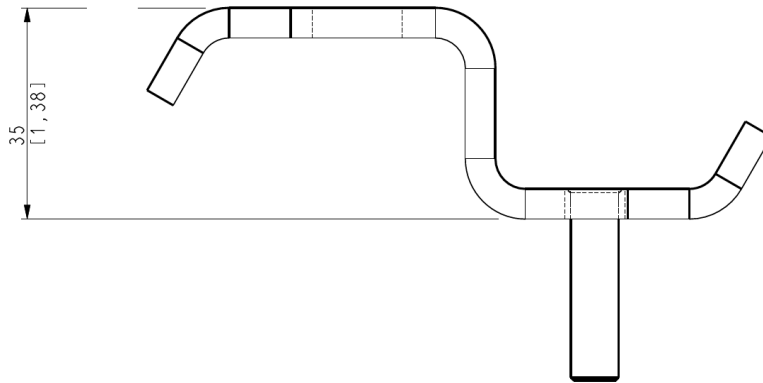
## 2.1.6 Remote Evaporator Reference Dimensions



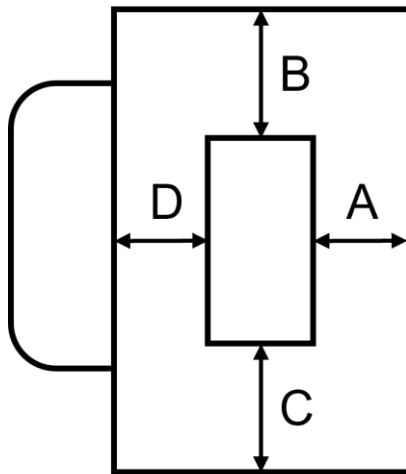
## Single Discharge (MSS) Evaporator Mounting Dimensions



## Dual Discharge (MSD) Evaporator Mounting Dimensions



Remote Evaporator Adapter Bracket Dimensions

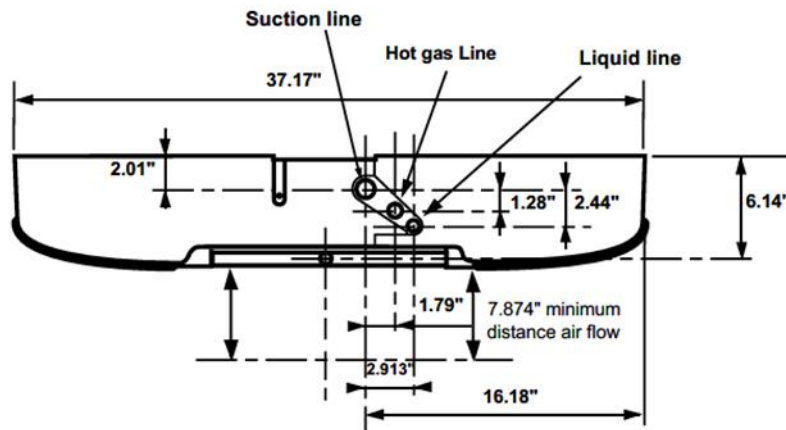


Minimum Clearance	Single Discharge Inches (mm)	Dual Discharge Inches (mm)
A	39.38 (1000)	39.38 (1000)
B	2.00 (50)	7.87 (200) <sup>a</sup>
C	2.00 (50)	2.00 (50)
D	7.87 (200) <sup>a</sup>	39.38 (1000)

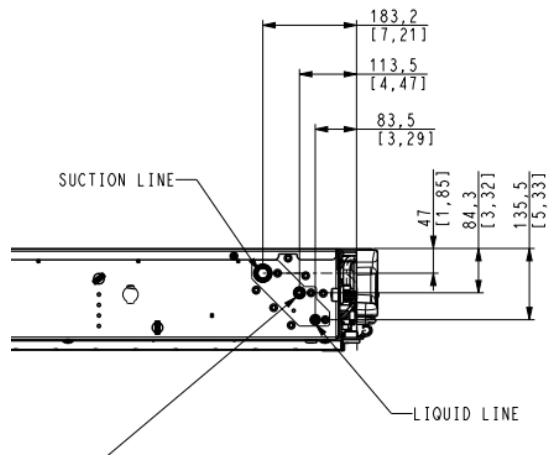
a. Refrigerant tube connection side

Table 5

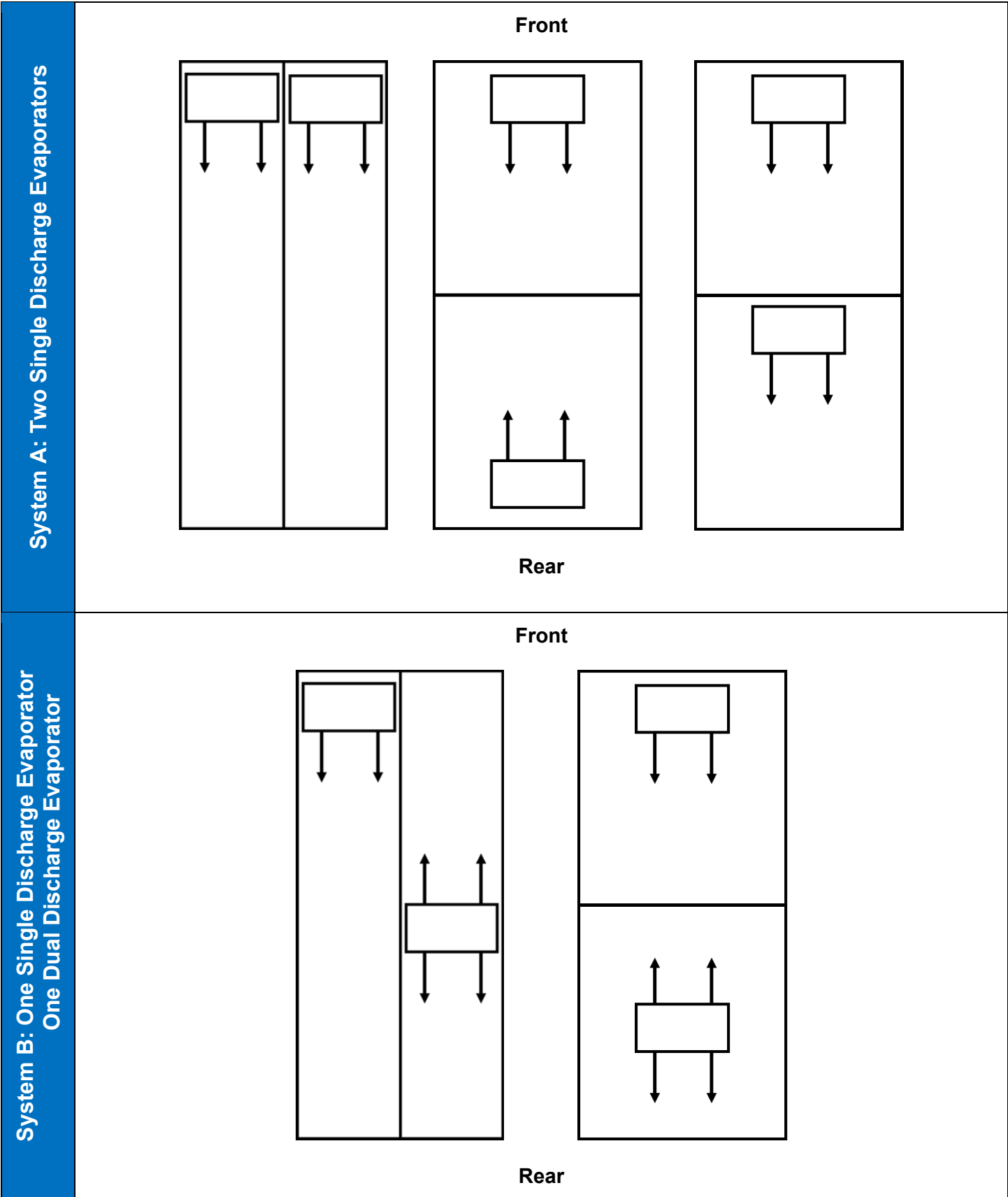
Minimum Evaporator Clearance Dimensions



**MSD Refrigeration  
Connections and Dimensions**

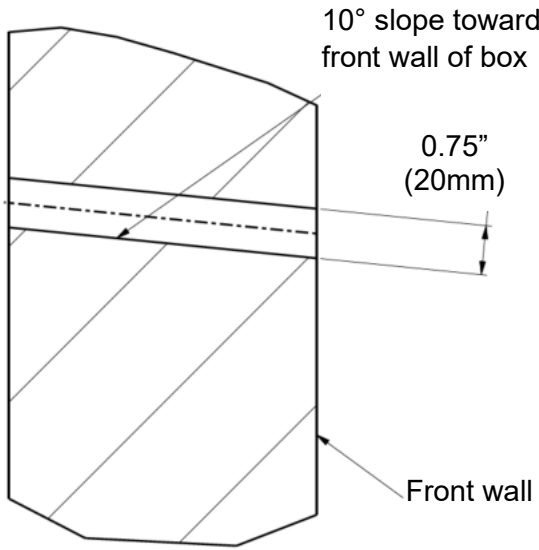
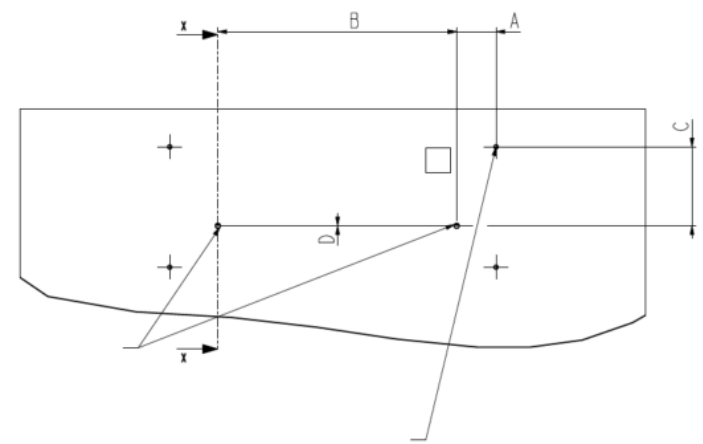
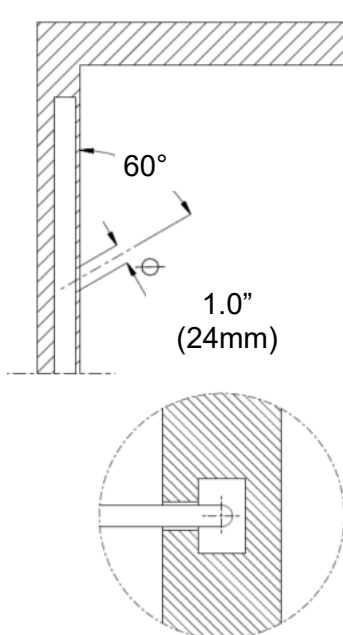
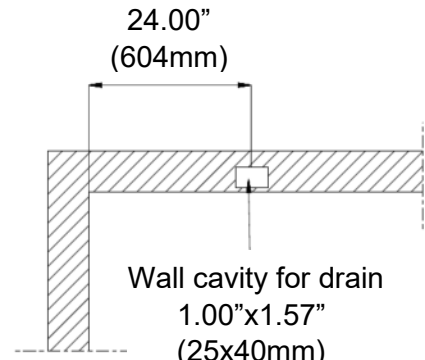


## 2.1.7 Remote Evaporator Configurations

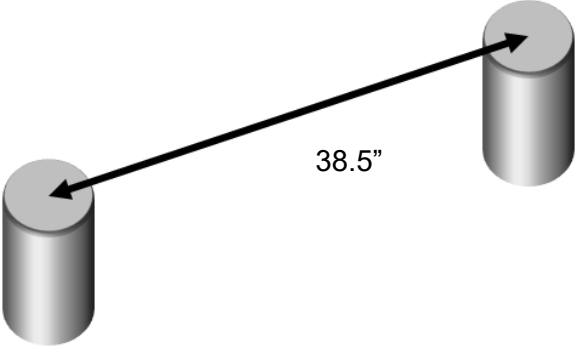
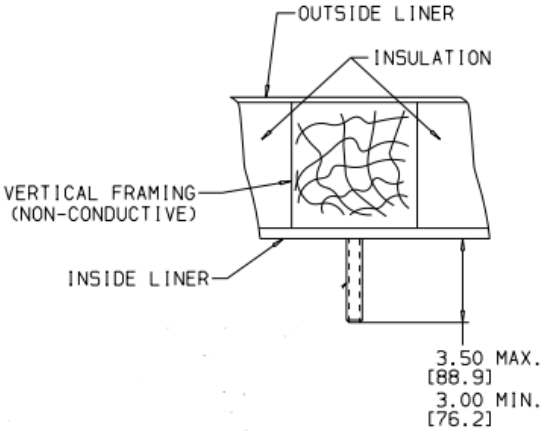
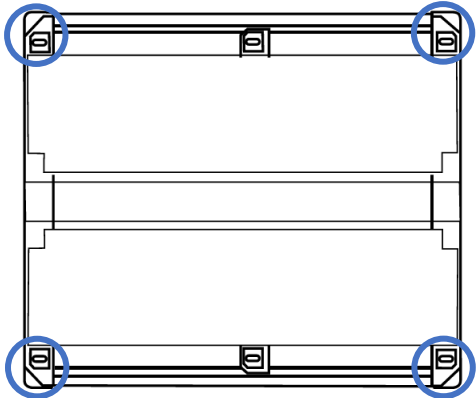
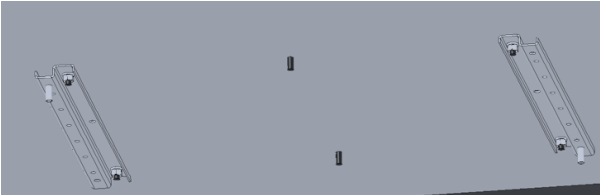






## 2.1.8 Defrost Drain Preparation

Each evaporator must have at least one defrost drain connected. The defrost drain can be configured for front, rear, or side drain. Refer to the following box preparation requirements for the drain configuration used.

Front Drain	 <p>10° slope toward front wall of box</p> <p>0.75" (20mm)</p> <p>Front wall</p>	 <p>Front wall</p>
Rear/Side Drain	 <p>60°</p> <p>1.0" (24mm)</p>	 <p>24.00" (604mm)</p> <p>Wall cavity for drain 1.00"x1.57" (25x40mm)</p>

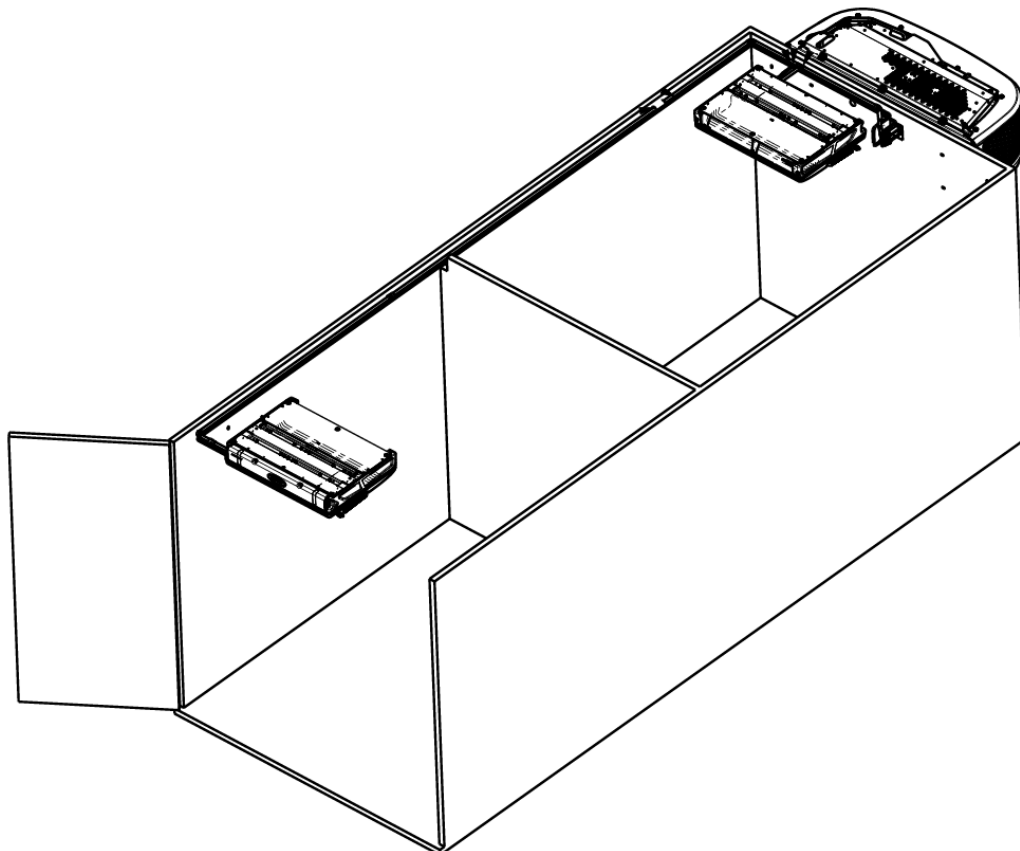
## 2.1.9 Evaporator Mounting

<p><b>1</b></p>	<p>If evaporator mounting studs have already been installed, proceed to step 2.</p> <p>If mounting studs have not been installed, determine the location in the box where the remote evaporator will be mounted according to desired configuration.</p> <p>See configuration considerations on the previous page.</p>	
<p><b>2</b></p>		<p>If existing studs are installed in the box ceiling, verify the stud width spacing to determine if remote evaporator adapter plate is required.</p> <p>If distance is 35.4", cut studs to 1-3/8". Adapter plates are required, go to step 3.</p> <p>If distance is 38.5", adapter plates are not required, go to step 4.</p> <p>If studs are not installed, go to step 2b</p>
<p><b>2b</b></p>		<p>See evaporator dimensions and configuration considerations above and install appropriate length bolts. The two center mounting studs are not required if 1/2-13 UNC studs are used on the four corner mounting locations.</p> 
<p><b>3</b></p>		<p>Position adapter plates over the studs with the adapter plate studs on the outside.</p> <p>Install using 1/2-13 nuts and washers.</p> <p>Tighten hardware.</p> <div style="text-align: center;">  <p><b>30 ft-lb</b></p> </div>


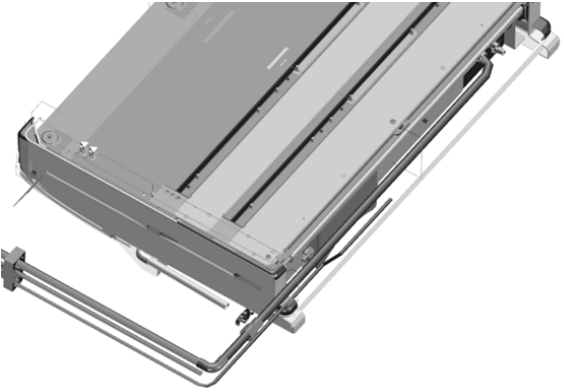
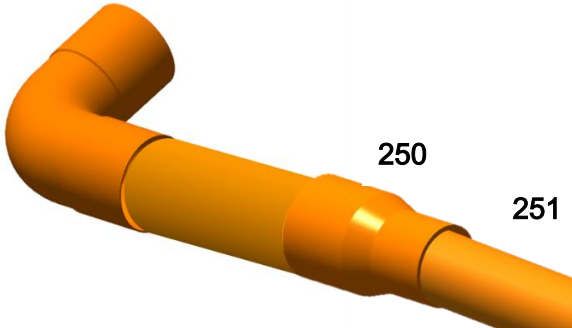
4		<p>Lift the remote evaporator into position over the studs.</p> <p>Use suitable lifting device for installing/removing the remote evaporator.</p> <div style="border: 1px solid black; background-color: yellow; padding: 5px; text-align: center;"> <p><b>⚠ CAUTION</b></p> <p>Evaporator weight: Single- 73lbs (33kg) Dual- 88lbs (40kg)</p> </div>
5		<p>Install 5/16-18 washers and nuts on studs.</p> <p>Tighten and torque hardware.</p> <div style="text-align: center;">  <p><b>15 ft-lb</b></p> </div>
6	Repeat process for additional remote evaporator	

### 2.1.10 Remote Evaporator Plumbing

Plumbing may vary based on configuration. See Figure 1 for basic configuration example.

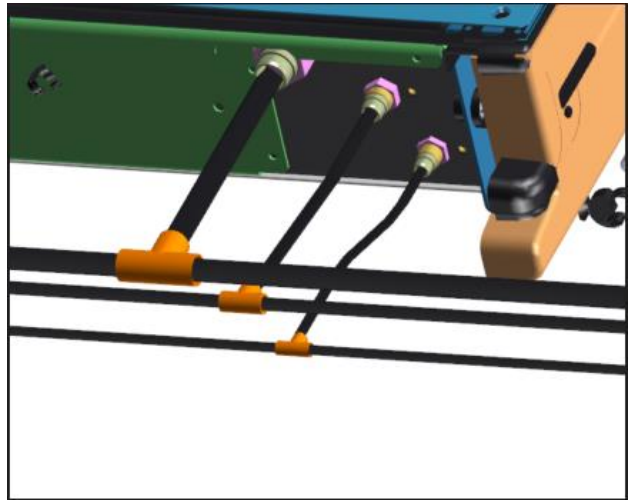
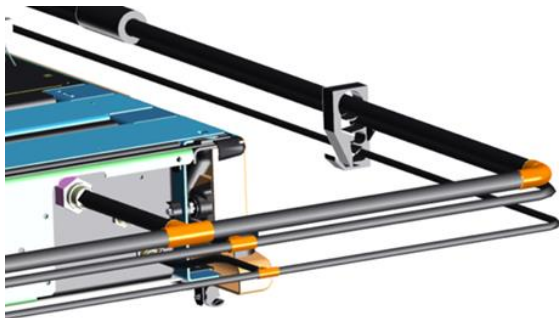


**Figure 1**

1	<p>Determine routing of plumbing from the remote evaporator to the host unit. It is recommended to install refrigerant tubing starting from the rear remote evaporator and working forward to the host. Three refrigerant tube connections are required at the host and each remote evaporator.</p> <ul style="list-style-type: none"> <li>• Liquid</li> <li>• Suction</li> <li>• Hot gas</li> </ul>
2	 <p>Connect preformed tubes (251,260,270) and ORS Nuts (30,40,50) to the rear remote evaporator refrigerant tube connections.</p> <p>Cut to length as required.</p>
3	 <p>Route refrigerant tubing from the rear remote to the front remote.</p> <p>The elbows, couplings, and tees required will vary based on configuration.</p> <p>1-1/8" to 7/8" coupling (250) is required to adapt the preformed suction tube (251) from the remote evaporator to the tubing going to the host unit.</p> 
4	<p>Connect refrigerant tubing from the rear remote to the front remote with tee fitting, tubing, and ORS fitting/nuts.</p> <p>Route tubing to host to the opposite side of the tee fitting.</p>

**CAUTION**

Do not install the o-rings until brazing is complete.

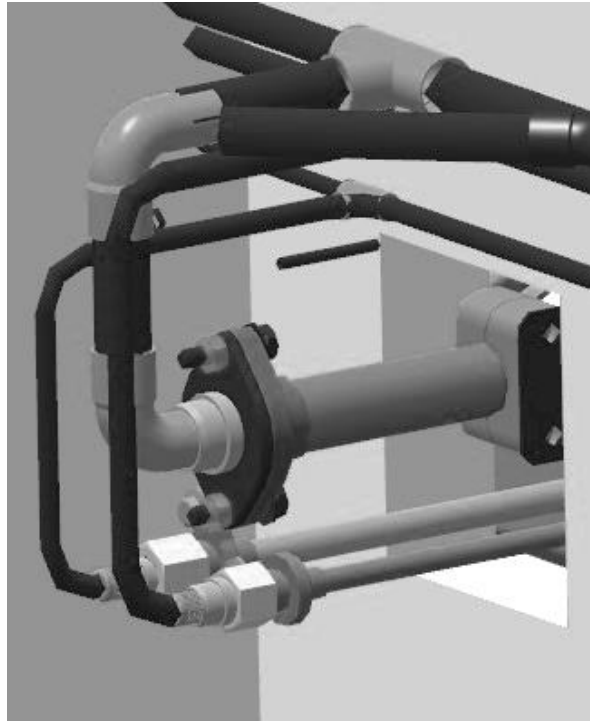


Install ORS flanges/nuts on the refrigerant tubing prior to making connections at the host.

**⚠ CAUTION**

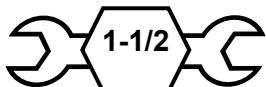
Do not install o-rings until brazing is complete.

5



6

The use of inert gas brazing procedures is mandatory for all Carrier Transicold refrigeration units otherwise, compressor failure will occur. For more information, Refer to Technical Procedure 98-50553-00. Allow all hot copper to cool down before installing o-rings, connecting, and torquing.



Suction: **60 ft-lb**

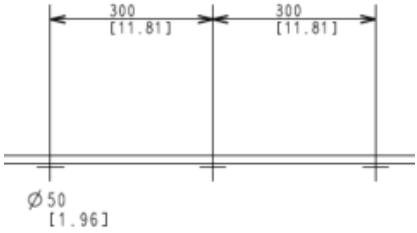
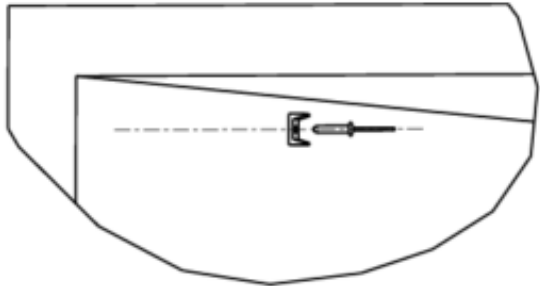

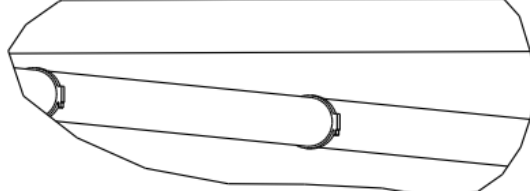

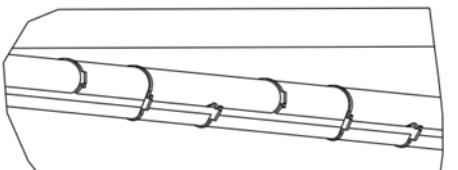
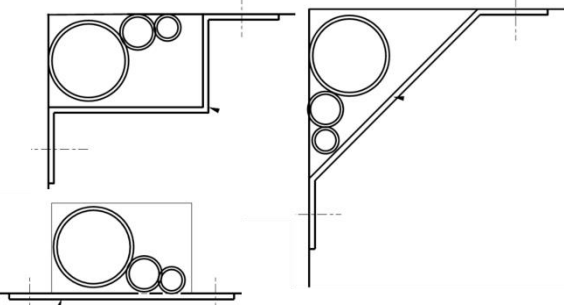


Hot Gas: **23 ft-lb**

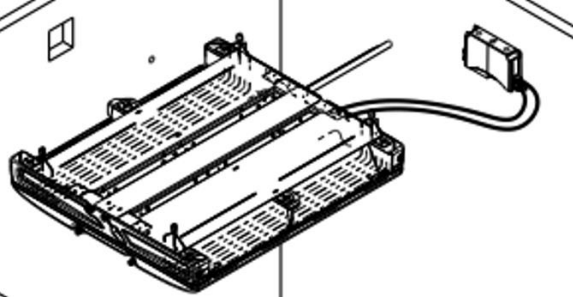



Liquid: **13 ft-lb**

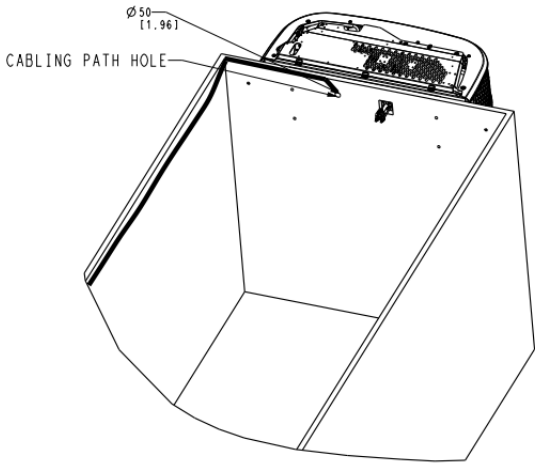

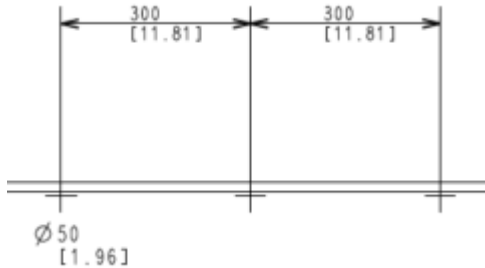
## 2.1.11 Securing and Insulating Refrigerant Tubing

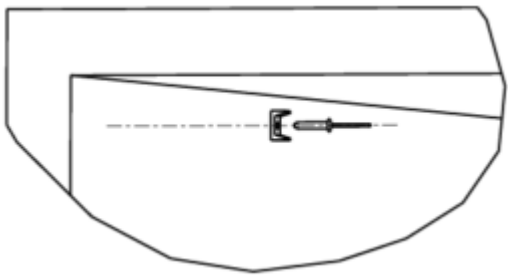

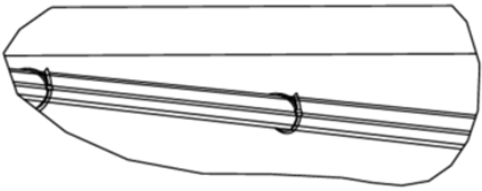







1	 <p>300 [11.81]      300 [11.81]</p> <p>∅ 50 [1.96]</p>	<p>Secure refrigerant tubing minimum every 12.00” (305mm)</p>
2		<p>Drill box wall.</p> <p>Insert rivet into plastic clip</p> <p>Inset rivet into wall ensuring clip and rivet head are flush with wall.</p> <p>Secure rivet with setting tool.</p>
		 <p>#5</p>
3		<p>Wrap the suction line with foam insulation.</p> <p>Sucure the suction line tubing to the wall with cable ties.</p>
4		<p>Wrap the hot gas line with foam insulation.</p> <p>Secure the hot gas line tubing to the suction line tubing with cable ties.</p>
5		<p>Secure the liquid line tubing to the hot gas line tubing with cable ties.</p>
6		<p>Install body builder supplied refrigerant tube cover.</p>



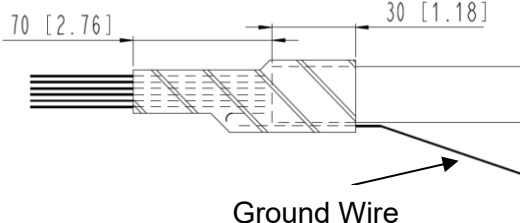
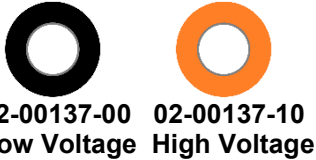
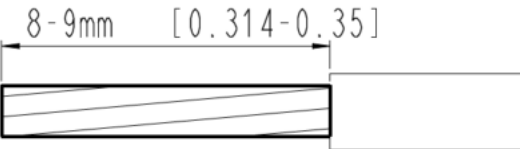
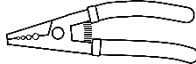
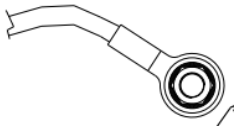

### 2.1.12 Junction Box Mounting (MSD Only)

1		<p>Determine the mounting location for the junction box.</p> <ul style="list-style-type: none"> <li>• Located inside the insulated truck box.</li> <li>• Secured to wall or ceiling of the insulated truck box.</li> <li>• Box/harness are not subject to physical damage.</li> <li>• Can be accessed for installation/service.</li> <li>• No more than 35.4" (900mm) from remote evaporator.</li> </ul>
2		<p>Secure the junction box to the wall or ceiling of the insulated truck box using self tapping screws.</p> <div style="text-align: center; border: 1px solid black; width: 50px; margin: 0 auto; padding: 5px;">10</div>

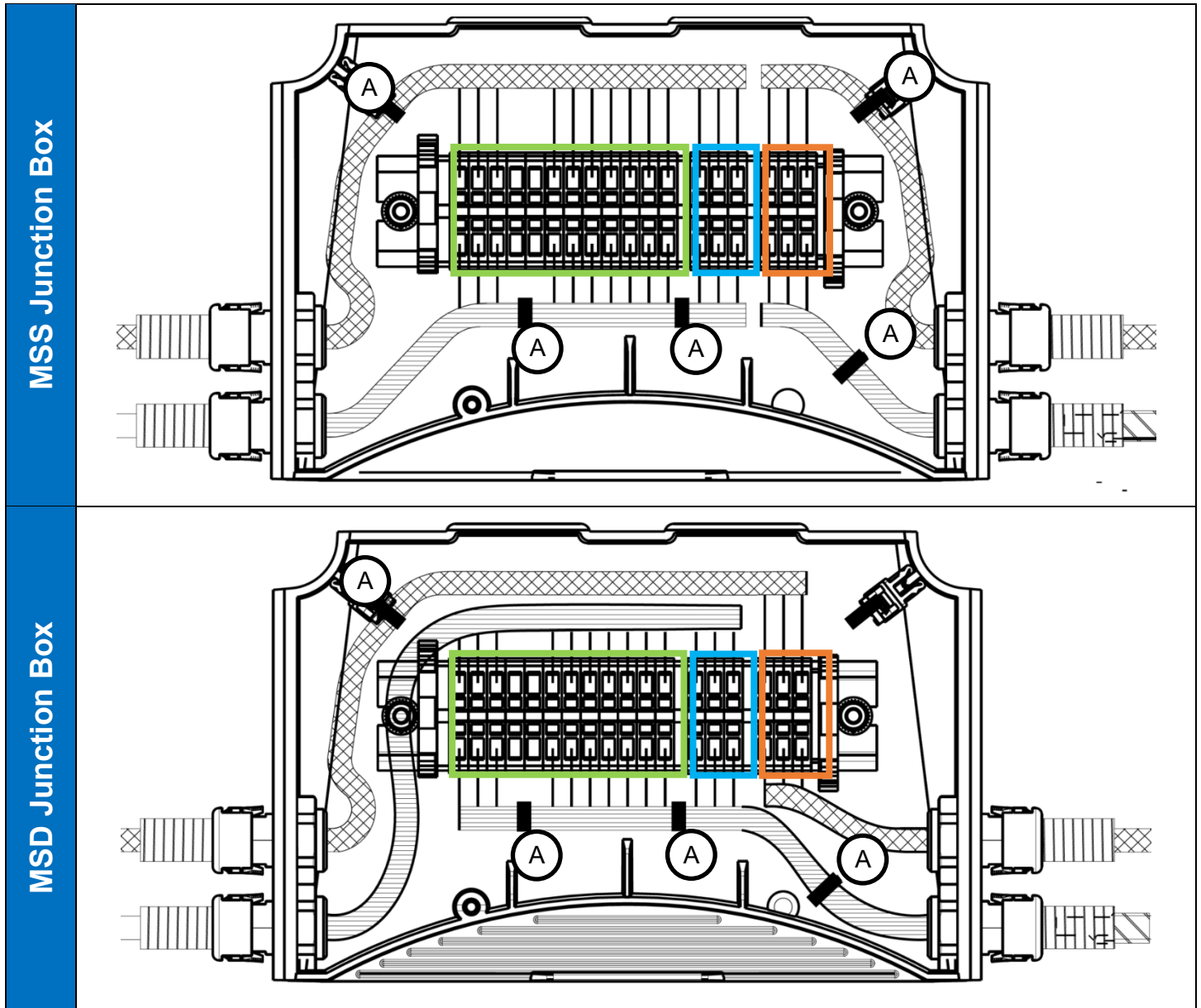
### 2.1.13 Remote Evaporator Wiring

1		<p>Determine routing of the low and high voltage harnesses from the host to each remote evaporator.</p> <p>Maintain separation between the high and low voltage harnesses as well as the refrigerant tubing.</p> <div style="text-align: center; border: 1px solid black; background-color: #e67e22; padding: 10px; margin: 10px 0;">  <b>WARNING</b> </div> <p>The refrigeration tubes and electrical harnesses shall not be in contact with each other where possible.</p> <p>Refer to 62-11869 Electrical Wiring and Harness Inspection and Repair Guidelines while routing electrical harnesses. Ensure electrical harnesses and wires are routed and secured away from contact with any objects such as studs, screws, threads, sharp corners, and terminal ends. If contact is unavoidable, suitable protective sleeve material must be used.</p>
		<p>Secure harness minimum every 12.00" (305mm)</p> <p>Secure harness at start/end of all bends</p>

2		<p>Drill box wall.</p> <p>Insert rivet into plastic clip</p> <p>Inset rivet into wall ensuring clip and rivet head are flush with wall.</p> <p>Secure rivet with setting tool.</p>
		
3		<p>Secure harness with cable ties.</p> <p>Trim excess cable length.</p>
		
4		<p>Route the harness across the top of the evaporator frame.</p> <p>Secure the harness to the frame with plastic clip and cable tie.</p>
		
5		<p>Loosen the screw securing the junction box to the junction box housing.</p> <p>Pull the junction box down.</p>
		
6		<p><b>NOTE: The connectors on the HVAC and HVDC harnesses for compartment one are not utilized for installation and will be removed. The compartment two harnesses have heat shrink applied to the ends of the wires.</b></p> <p>Cut the harness to length so there is not any excess length that requires bundling.</p> <p>Allow 13.78" (350mm) for junction box connections.</p>
		

7		<p>Trim the protective covering from the harness to the length shown.</p> <p style="text-align: center;"><b>NOTICE</b></p> <p>Cut the protective covering with sharp utility scissors. Cutting with knife will result in frayed ends.</p>									
											
8		<p>Tape the exposed wires to the protective covering with the dimensions shown.</p> <p>Extend the earth ground (green/yellow) or ground (black) wire beyond the tape.</p> <p><b>NOTE: Earth ground may not be present on all models.</b></p>									
											
9	<p>Trim the earth ground/ground wire to length.</p> <table border="1" data-bbox="196 1073 732 1209"> <thead> <tr> <th>Evaporator</th> <th>Inches</th> <th>mm</th> </tr> </thead> <tbody> <tr> <td>Single</td> <td>7.87</td> <td>200</td> </tr> <tr> <td>Dual</td> <td colspan="2">Cut to length based on junction box location</td> </tr> </tbody> </table>	Evaporator	Inches	mm	Single	7.87	200	Dual	Cut to length based on junction box location		
Evaporator	Inches	mm									
Single	7.87	200									
Dual	Cut to length based on junction box location										
10		<p>Remove the insulation from the end of the ground wire.</p>									
											
11		<p>Install heat shrink tubing on the end of the ground wire.</p> <p>Crimp ring terminal on the end of the wire.</p> <p>Apply heat to heat shrink tubing to seal.</p>									
											

## 2.1.14 Junction Box Connections

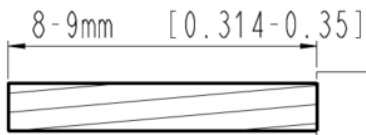


Connector Function	JB1 Sensors and DC Low Actuators											
Junction Position	1B	2B	3B	1B	2B	3B	1B	2B	3B	4B	5B	6B
Wire Color	Yellow "1"	Yellow "2"	Black "1"	Black "2"	Brown "1"	Brown "2"	Purple	White	Grey "1"	Grey "2"	Orange "1"	Orange "2"
Cut Length (mm)	150	180	220	170	150	180	220	170	150	180	220	170
Cut Length (in)	5.91	7.09	8.66	6.69	5.91	7.09	8.66	6.69	5.91	7.09	8.66	6.69
Function	DTS	DTS	RAS	RAS	SAT	SAT	HGV	LSV/DWR	DS	DS	HT	HT

Connector Function	JB3 DC Fans			JB4 AC Heaters		
Junction Position	7B	8B	9B	10B	11B	12B
Wire Color	White "1"	White "2"	White "3"	Red "3"	Red "2"	Red "1"
Cut Length (mm)	150	180	220	170	150	180
Cut Length (in)	5.91	7.09	8.66	6.69	5.91	7.09
Function	EFM1	EFM2	EFM3	HTR1-PH1	HTR1-PH2	HTR1-PH3

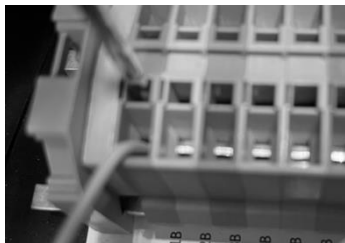
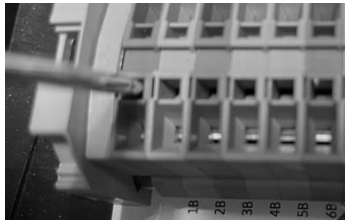
**1** Cut each wire to length listed in the tables above.

**2**



Strip the insulation from the end of each wire.

**3**



Insert the tool into (center opening) of the terminal block and pivot slightly upward to release the lock.

Insert wire in the terminal block cavity. See table above for correct wire locations.

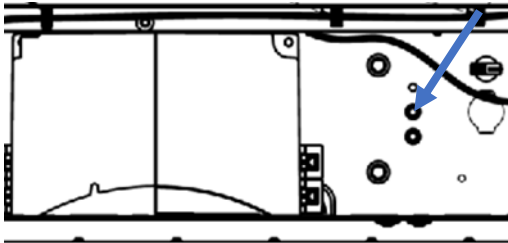
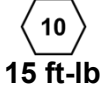
Remove the tool.

Repeat process for the remaining wires.

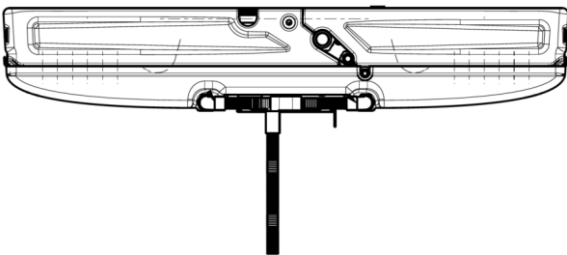
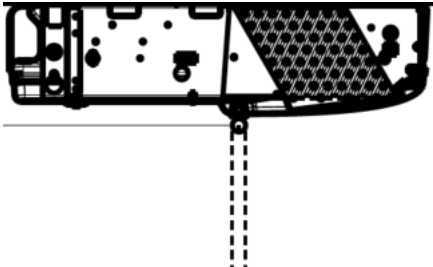
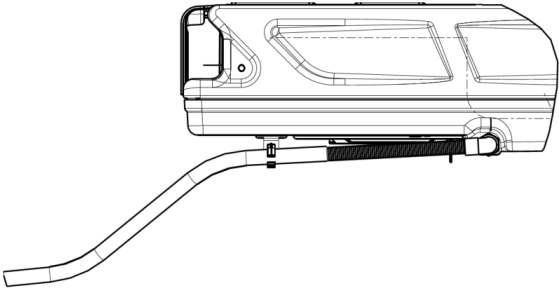
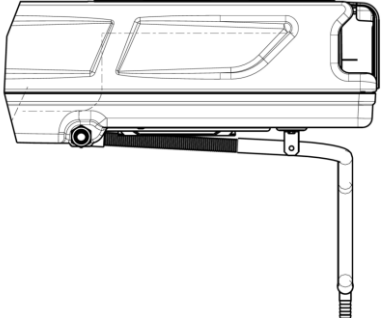
Install tie wraps in the locations marked A in the images above.

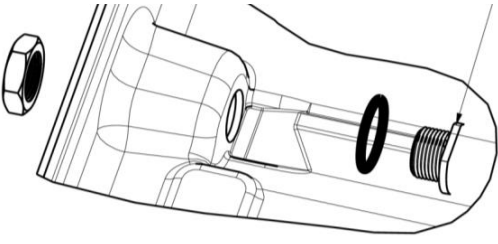

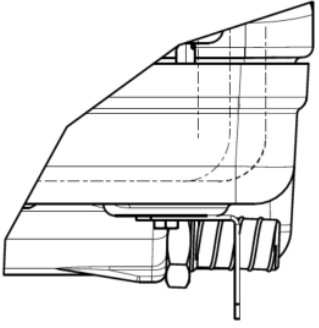
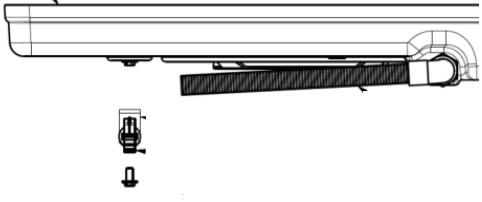


**07-60181-00**




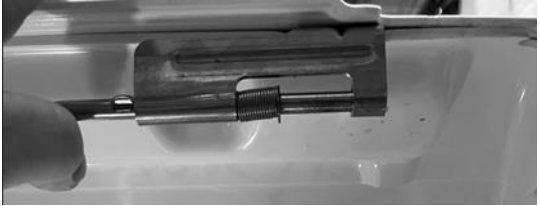





4		<p>Remove the M6 nut at the location shown.</p> <p>Install the ground ring terminals on the ground stud on the evaporator frame.</p> <p>Reinstall nut and tighten and torque.</p> <p>Apply glyptal</p>
		

**2.1.15 Drain Hose and Water Heater Wire**

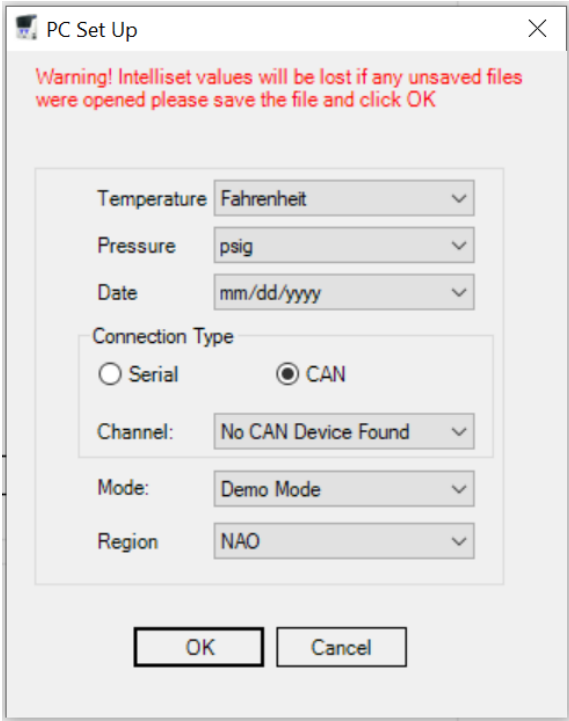
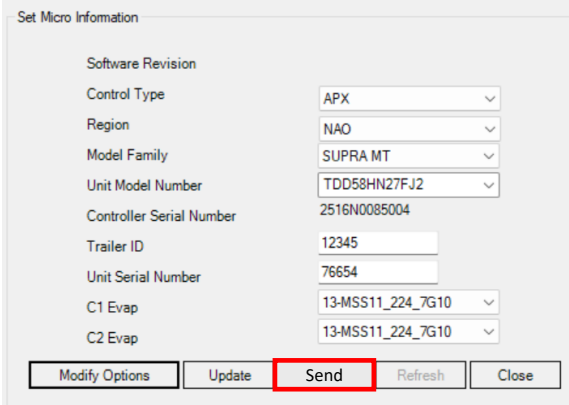
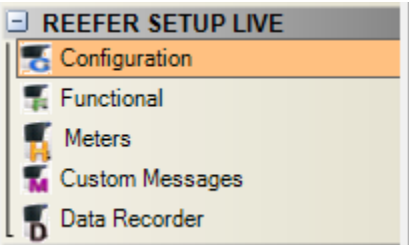
4	<p>Determine defrost drain configuration and number of drain tubes that will be used for the application.</p> <p>If single drain will be used, remove defrost drain fitting from the side that will not be used and insert drain plug.</p> <p>Once hoses are installed, route to box drain hole location.</p> <p>See below for possible drain hose configurations.</p>	
Side	 <p><b>Dual Discharge Side Exit Single</b></p>	 <p><b>Single Discharge Side Exit</b></p>
Front/Rear Side Offset	 <p><b>Front/Rear Exit</b></p>	 <p><b>Side Offset Exit</b></p>

<b>Defrost Drain Plug Installation</b>		<p>Separate the defrost drain tube from the drain tube fitting.</p> <p>Remove the nut securing the drain fitting to the remote evaporator cover.</p> <p>Install o-ring on the drain plug cap (130).</p> <p>Insert drain plug in the remote evaporator fitting.</p> <p>Install nut on the drain plug and tighten until snug.</p>
<b>Water Heater Installation</b>		<p>Insert drain water heater wire loop into drain fitting.</p> <p>Insert drain water heater into the drain hose.</p> <p>Push drain hose on to drain fitting.</p> <p>Repeat for opposite side if necessary.</p> <p>If second drain is not used, remove drain heater wire.</p>
<b>Drain Hose Support Bracket Installation</b>		<p>Orient defrost drain support bracket as shown.</p> <p>Secure bracket to remote evaporator cover with bolt.</p> <p>Insert clamp into bracket.</p>
<b>Drain Hose Clamp</b>		<p>Secure defrost drain tube to clamp.</p>

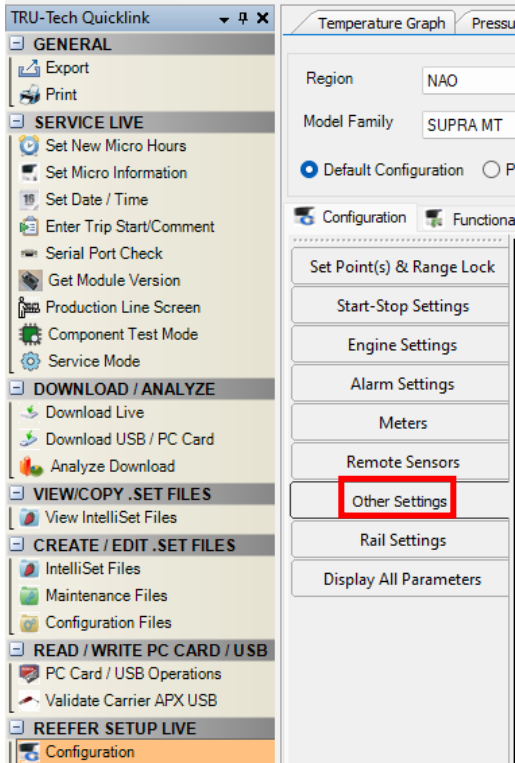
## 2.1.16 Unit Cover Installation

MSS Cover	 	<p>Carefully lift the evap cover and place the back hinges into the notches at the front of the remote evap.</p> <p>Swing the cover up into place until it snaps into tabs and install the six torx bolts.</p> 
MSD Cover	   	<p>Engage each of the 4 spring hinges on the evap cover and turn to lock in place</p> <p>Carefully lift the evap cover into place and align either the front 2 spring hinges or the rear 2 spring hinges with the cover mounting holes</p> <p>Rotate each hinge inward to disengage and insert into the mounting holes.</p> <p>Install the T35 torx mounting bolts and torque.</p> <p><b>NOTE: Having an additional technician to help support the cover on MSD evaps will aid in installation and removal.</b></p>
		 <p><b>3 ft-lb</b></p>
		 <p><b>3 ft-lb</b></p>

## 2.1.17 Configuration Settings

<p style="font-size: 2em; font-weight: bold; text-align: center;">1</p>		<p>Go to Preferences Tab and Select PC Set Up</p> <p>Verify Region is set to NAO</p> <p><b>NOTE: You must use TRU-Tech™ and TRU-View™ version 01.19.00 or later to configure MT units.</b></p>																
<p style="font-size: 2em; font-weight: bold; text-align: center;">2</p>		<p>Connect CAN Adapter</p> <p>TRU-Tech&gt; Service Live&gt; Set Micro Information</p> <table border="1" data-bbox="776 1081 1487 1367"> <tr> <td><b>Control Type</b></td> <td>APX</td> </tr> <tr> <td><b>Region</b></td> <td>NAO</td> </tr> <tr> <td><b>Model Family</b></td> <td>SUPRA MT</td> </tr> <tr> <td><b>Unit Model Number</b></td> <td>Refer to host data tag</td> </tr> <tr> <td><b>Trailer ID</b></td> <td>Customer</td> </tr> <tr> <td><b>Unit Serial Number</b></td> <td>Refer to host data tag</td> </tr> <tr> <td><b>C1 Evap</b></td> <td>Select MSS or MSD*</td> </tr> <tr> <td><b>C2 Evap</b></td> <td>Select MSS or MSD*</td> </tr> </table> <p>Press Send.</p> <p><b>*NOTE: Only MSS11_224_7G10 and MSD11_224_7G10 are used in North America</b></p>	<b>Control Type</b>	APX	<b>Region</b>	NAO	<b>Model Family</b>	SUPRA MT	<b>Unit Model Number</b>	Refer to host data tag	<b>Trailer ID</b>	Customer	<b>Unit Serial Number</b>	Refer to host data tag	<b>C1 Evap</b>	Select MSS or MSD*	<b>C2 Evap</b>	Select MSS or MSD*
<b>Control Type</b>	APX																	
<b>Region</b>	NAO																	
<b>Model Family</b>	SUPRA MT																	
<b>Unit Model Number</b>	Refer to host data tag																	
<b>Trailer ID</b>	Customer																	
<b>Unit Serial Number</b>	Refer to host data tag																	
<b>C1 Evap</b>	Select MSS or MSD*																	
<b>C2 Evap</b>	Select MSS or MSD*																	
<p style="font-size: 2em; font-weight: bold; text-align: center;">3</p>		<p>In the TRU-Tech Quicklink, go to Reefer Setup Live</p> <p>Select Configuration</p>																

4



Go to Other Settings

5

Parameter	Value
Enable Advance User	No
Parameters Lockout	No
8Hr Additional Data	No
Satellite Comm	Other
High Speed Delay	1 Minutes
Light Bar	Not Installed
No A/C Power	Alarm & Shutdown
Standby Startup Delay	Off
C2 Evap	13-MSS11_224_7G10
Number Of Comm Modules	Not Installed
Number Of Remote Panels	Not Installed
Engine Commissioning	Installed
C1 Evap	13-MSS11_224_7G10

Select the correct Evap model number\* for each compartment

Press Send at the bottom of the page

**\*NOTE: Only MSS11\_224\_7G10 and MSD11\_224\_7G10 are used in North America**

6

Close TTTV


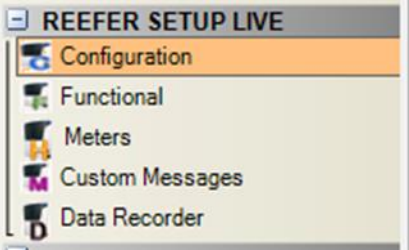
Disconnect the CAN adapter from the unit

Turn the unit off

Perform a hard reboot (disconnect the NEGATIVE cable from the unit battery for at least 2 mins) on the unit

**NOTE: This is a CRITICAL step to follow after making any changes to any unit configurations.**

## 2.1.18 Door Switch Connections and Configuration

<p>1</p>		<p>Install and route door switches and wires according to customer request.</p> <p>Remove the evap skin for each compartment that will get a door switch.</p> <p>Open the junction box, pull it far enough down to reach the upper wires.</p> <p>Remove the grey jumper wire at JB1-9 and JB1-10</p> <p>Install door switch wires into JB1-9 and JB1-10</p>																								
<p>2</p>		<p>Connect CAN Adapter to unit and laptop.</p> <p>Open TTTV</p> <p>In the TRU-Tech Quicklink, go to Reefer Setup Live</p> <p>Select Configuration</p>																								
<p>3</p>	<table border="1" data-bbox="180 1077 748 1262"> <thead> <tr> <th>Set Point(s) &amp; Range Lock</th> <th>Parameter</th> <th>Value</th> </tr> </thead> <tbody> <tr> <td>Start-Stop Settings</td> <td>Remote Temp Sensor2/ Redundant RAT</td> <td>Not Installed</td> </tr> <tr> <td>Engine Settings</td> <td>Door Switch</td> <td>Door Open Switch Open</td> </tr> <tr> <td>Engine Settings</td> <td>Door Switch Shutdown</td> <td>Compartment One Shutdown</td> </tr> <tr> <td>Alarm Settings</td> <td>Unit Shutdown Below</td> <td>Off</td> </tr> <tr> <td>Meters</td> <td>Engine Speed</td> <td>Normal</td> </tr> <tr> <td>Remote Sensors</td> <td>Run Low Speed Below</td> <td>Off</td> </tr> <tr> <td></td> <td>REMS 1</td> <td>Not Installed</td> </tr> </tbody> </table>	Set Point(s) & Range Lock	Parameter	Value	Start-Stop Settings	Remote Temp Sensor2/ Redundant RAT	Not Installed	Engine Settings	Door Switch	Door Open Switch Open	Engine Settings	Door Switch Shutdown	Compartment One Shutdown	Alarm Settings	Unit Shutdown Below	Off	Meters	Engine Speed	Normal	Remote Sensors	Run Low Speed Below	Off		REMS 1	Not Installed	<p>Select Remote Sensors</p> <p>For <b>Compartment 1</b>: Select the correct option depending on doorswitch type under Door Switch</p> <p>Select the option that the customer requests</p> <p><b>NOTE: The option in the image is just one of the options, the only other functioning options are Alarm Only, Unit Shutdown, or Data Recorder Only</b></p>
Set Point(s) & Range Lock	Parameter	Value																								
Start-Stop Settings	Remote Temp Sensor2/ Redundant RAT	Not Installed																								
Engine Settings	Door Switch	Door Open Switch Open																								
Engine Settings	Door Switch Shutdown	Compartment One Shutdown																								
Alarm Settings	Unit Shutdown Below	Off																								
Meters	Engine Speed	Normal																								
Remote Sensors	Run Low Speed Below	Off																								
	REMS 1	Not Installed																								
<p>4</p>	<table border="1" data-bbox="180 1465 748 1535"> <tbody> <tr> <td>REMS 3</td> <td>Door Open Switch Open</td> </tr> <tr> <td>REMS 3</td> <td>Compartment Two Shutdown</td> </tr> </tbody> </table>	REMS 3	Door Open Switch Open	REMS 3	Compartment Two Shutdown	<p>For <b>Compartment 2</b>: Select the correct option depending on doorswitch type under REMS 3</p> <p>Select the option that the customer requests</p> <p><b>NOTE: The option in the image is just one of the options, the only other functioning options are Alarm Only, Unit Shutdown, or Data Recorder Only</b></p>																				
REMS 3	Door Open Switch Open																									
REMS 3	Compartment Two Shutdown																									

# 5

Press Send at the bottom of the page


Close TTTV

Disconnect the CAN adapter from the unit

Turn the unit off

Perform a hard reboot (disconnect the NEGATIVE cable from the unit battery for at least 2 mins) on the unit

**NOTE: This is a CRITICAL step to follow after making any changes to any unit configurations.**

 **WARNING:** Breathing diesel engine exhaust exposes you to chemicals known to the State of California to cause cancer and birth defects or other reproductive harm.

- Always start and operate engine in a well-ventilated area.
- If in an enclosed area, vent the exhaust to the outside.
- Do not modify or tamper with the exhaust system.
- Do not idle the engine except as necessary.

For more information, go to [www.P65warnings.ca.gov/diesel](http://www.P65warnings.ca.gov/diesel)



North America  
Carrier Transicold  
700 Olympic Drive  
Athens, GA 30601  
USA

Central America and Mexico  
Carrier Transicold  
Ejercito Nacional 253-A Piso 5  
Colonia Anahuac 11320  
Mexico D.F.